



Bobcat®

Operation & Maintenance Manual

Drop Hammer

S/N A78D00101 & Above

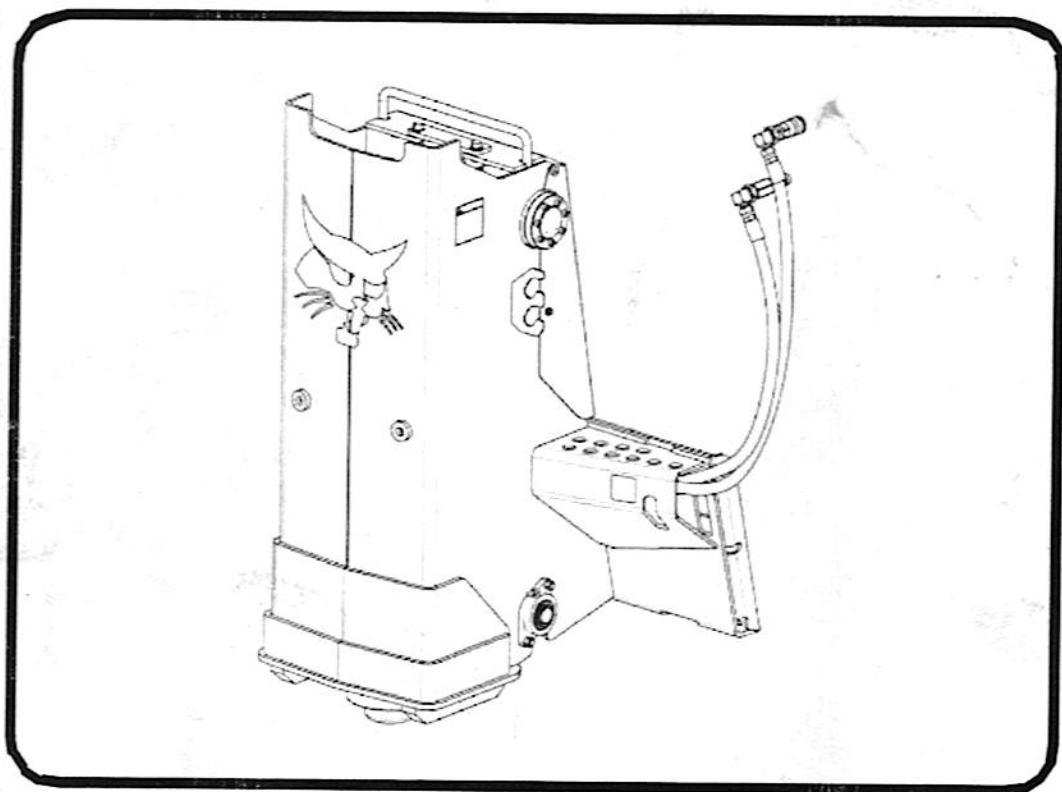

CONTENTS

FOREWORD.....	III
SAFETY & TRAINING RESOURCES.....	IX
OPERATING INSTRUCTIONS.....	OI-1
PREVENTIVE MAINTENANCE.....	PM-1
SPECIFICATIONS.....	SPEC-1
WARRANTY.....	WARRANTY-1
ALPHABETICAL INDEX.....	INDEX-1

REFERENCE INFORMATION

Write the correct information for YOUR Drop Hammer in the spaces below. Always use these numbers when referring to your Drop Hammer.

Drop Hammer Serial Number

NOTES:

YOUR BOBCAT® DEALER:

ADDRESS:

PHONE:

Bobcat Company
P.O. Box 128
Gwinner, ND 58040-0128

Bobcat Company Europe
Drève Richelle 167
B-1410 WATERLOO
Belgium

FOREWORD

**SAFETY &
TRAINING
RESOURCES**

**OPERATING
INSTRUCTIONS**

**PREVENTIVE
MAINTENANCE**

SPECIFICATIONS

WARRANTY

**ALPHABETICAL
INDEX**

FOREWORD

FOREWORD

This Operation & Maintenance Manual was written to give the owner/operator instructions on the safe operation and maintenance of the Drop Hammer. **READ AND UNDERSTAND THIS OPERATION & MAINTENANCE MANUAL BEFORE OPERATING YOUR Drop Hammer.** If you have any questions, see your Bobcat dealer.

DELIVERY REPORT.....	VI
FEATURES AND ACCESSORIES	VIII
Standard Items.....	VIII
IDENTIFICATION AND MACHINE SIGNS (DECALS)	VII
SERIAL NUMBER LOCATION	VI



ISO 9001:2000 is a set of international standards that control the processes and procedures which we use to design, develop, manufacture, distribute, and service Bobcat products.

British Standards Institute (**BSI**) is the Certified Registrar Bobcat chose to assess the Company's compliance with the ISO 9001:2000 set of standards. The BSI registration certifies that the two Bobcat manufacturing plants and the Bobcat corporate offices (Gwinner, Bismarck & West Fargo) in North Dakota are in compliance with ISO 9001:2000. Only certified assessors, like BSI, can grant registrations.

ISO 9001:2000 means that as a company we say what we do and do what we say. In other words, we have established procedures and policies, and we provide evidence that the procedures and policies are followed.

SERIAL NUMBER LOCATION

Figure 1

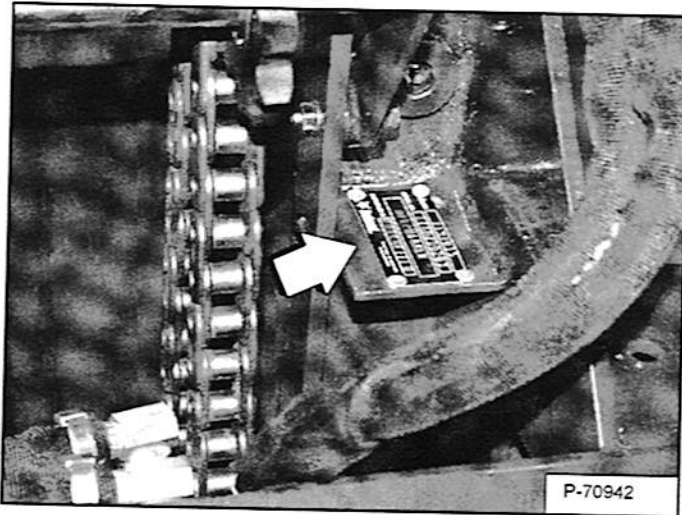

NOTE: The Drop Hammer serial number tag is located under the cover.

Always use the serial number of the Drop Hammer when requesting service information or when ordering parts. Early or later models (identification made by serial number) may use different parts, or it may be necessary to use a different procedure in doing a specific service operation [Figure 1].

DELIVERY REPORT

Figure 2

The delivery report must be filled out by the dealer and signed by the owner or operator when the Drop Hammer is delivered. An explanation of the form must be given to the owner. Make sure it is filled out completely [Figure 2].

IDENTIFICATION AND MACHINE SIGNS (DECALS)

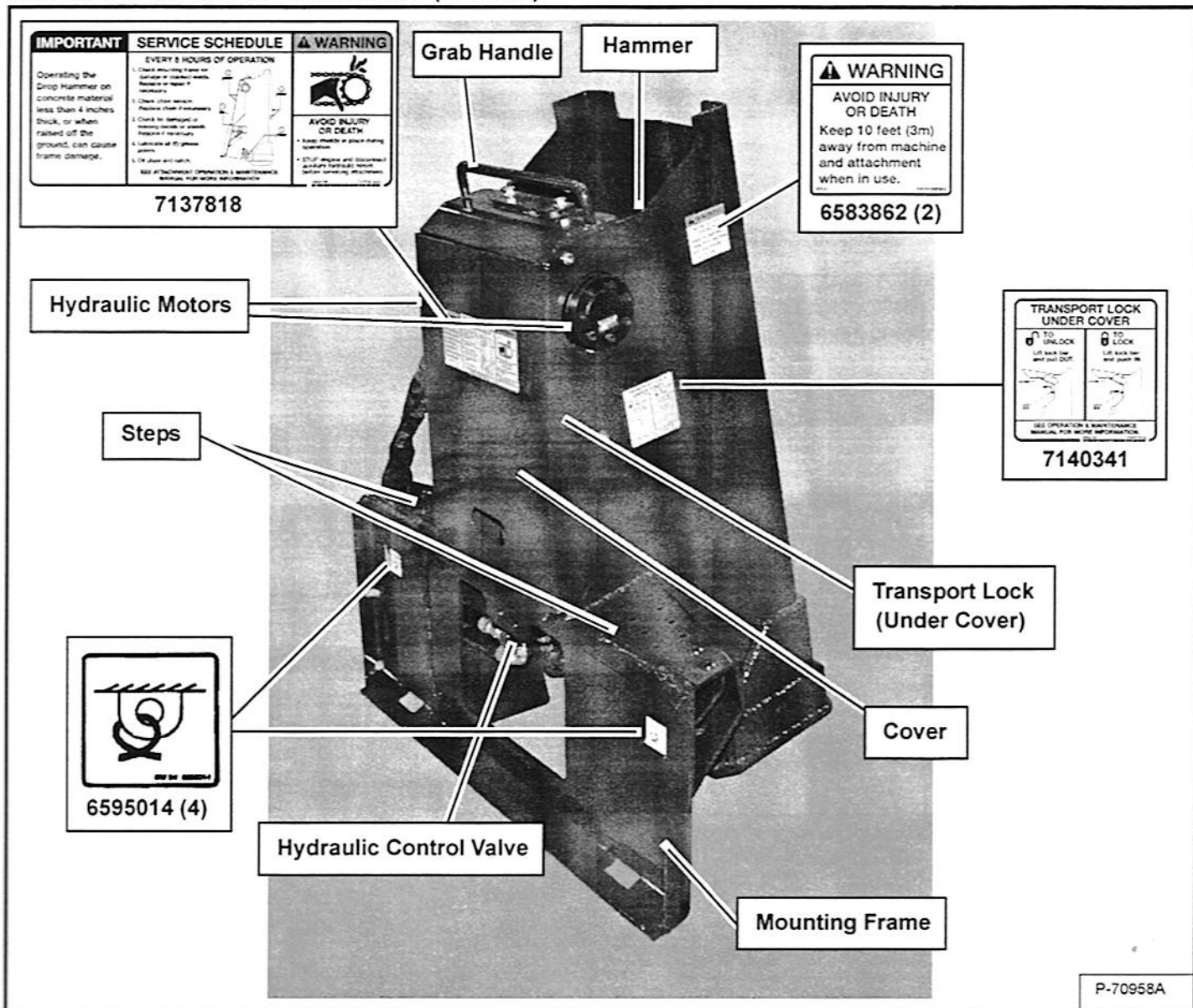

FEATURES AND ACCESSORIES

Standard Items

The Drop Hammer is equipped with the following standard items.

- Dual motors with chain drive.
- Transport Lock.
- Cushioned Safety Valve: Allows the weight to slowly lower if the hydraulic oil flow is stopped before the weight reaches full dropping height.
- Hydraulic Coupler Storage Bracket.

SAFETY INSTRUCTIONS

Safe Operation Is The Operator's Responsibility

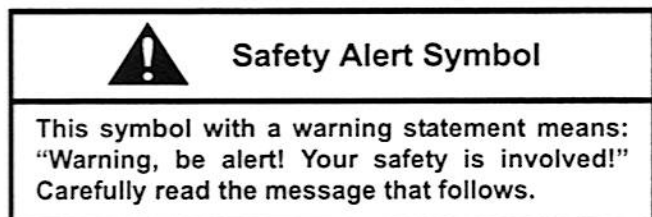

Operator must have instructions before running the machine. Untrained operators can cause injury or death.

W-2001-1285



This notice identifies procedures which must be followed to avoid damage to the machine.

I-2019-0284



Warnings on the machine and in the manuals are for your safety. Failure to obey warnings can cause injury or death.

W-2044-1285

The Bobcat machine and attachment must be in good operating condition before use.

Check all of the items on the Bobcat Service Schedule Decal under the 8-10 hour column or as shown in the Operation & Maintenance Manual.

Safe Operation Needs A Qualified Operator

For an operator to be qualified, he or she must not use drugs or alcoholic drinks which impair alertness or coordination while working. An operator who is taking prescription drugs must get medical advice to determine if he or she can safely operate a machine.

A Qualified Operator Must Do The Following:

Understand the Written Instructions, Rules and Regulations

- The written instructions from Bobcat Company include the Delivery Report, Operation & Maintenance Manual, Operator's Handbook, Safety Manual and machine signs (decals).
- Check the rules and regulations at your location. The rules may include an employer's work safety requirements. Regulations may apply to local driving requirements or use of a Slow Moving Vehicle (SMV) emblem. Regulations may identify a hazard such as a utility line.

Have Training with Actual Operation

- Operator training must consist of a demonstration and verbal instruction. This training is given by your Bobcat dealer before the product is delivered.
- The new operator must start in an area without bystanders and use all the controls until he or she can operate the machine and attachment safely under all conditions of the work area. Always fasten seat belt before operating.

Know the Work Conditions

- Know the weight of the materials being handled. Avoid exceeding the machine load capacities. Material which is very dense will be heavier than the same volume of less dense material. Reduce the size of load if handling dense material.
- The operator must know any prohibited uses or work areas, for example, he or she needs to know about excessive slopes.
- Know the location of any underground lines. Call local utilities or the TOLL FREE phone number found in the *USE SAFETY RULES* Section of this manual.
- Wear tight fitting clothing. Always wear safety glasses when doing maintenance or service. Safety glasses, hearing protection, Special Applications Kits or a Front Window Guard are required for some work. See your Bobcat dealer about Bobcat Safety equipment for your machine.

SI ATT-0805

SAFETY INSTRUCTIONS (CONT'D)

Use Safety Rules

- Read and follow instructions in the machine and the attachment's Operation & Maintenance Manual before operating.
- Check for underground lines before operating attachment (if applicable).
- In addition to the design and configuration of equipment, hazard control and accident prevention are dependent upon the awareness, concern, prudence and proper training of personnel involved in the operation, transport, maintenance and storage of equipment.
- Check that the Bob-Tach levers are in the locked position and the wedges are fully engaged into the holes of the attachment (if applicable).
- Check that the attachment is securely fastened to the machine.
- Make sure all the machine controls are in the NEUTRAL position before starting the machine.
- Operate the attachment only from the operator's position.
- When learning to operate the attachment, do it at a slow rate in an area clear of bystanders.
- DO NOT permit personnel to be in the work area when operating the machine and attachment.
- The attachment must be used ONLY on approved machines. See your Bobcat dealer for updated list of approved attachments for each machine model.
- DO NOT modify equipment or add attachments that are not approved by the manufacturer.
- DO NOT make any adjustments or repairs on the machine or attachment while the engine is running.



Call Before You Dig

1-888-258-0808

When you call, you will be directed to a location in your state/city for information about buried lines (telephone, cable TV, water, sewer, gas, etc.)

SAFETY INSTRUCTIONS (CONT'D)

Fire Prevention

The machines and some attachments have components that are at high temperatures under normal operating conditions. The primary source of high temperatures is the engine and exhaust system. The electrical system, if damaged or incorrectly maintained, can be a source of arcs or sparks.

Flammable debris (leaves, straw, etc.) must be removed regularly. If flammable debris is allowed to accumulate, it can cause a fire hazard. Clean often to avoid this accumulation. Flammable debris in the engine compartment is a potential fire hazard.

The spark arrestor exhaust system (if equipped) is designed to control the emission of hot particles from the engine and exhaust system, but the muffler and the exhaust gases are still hot.

- Do not use the machine where exhaust, arcs, sparks or hot components can contact flammable material, explosive dust or gases.
- The operator cab (if equipped), engine compartment and engine cooling system must be inspected every day and cleaned if necessary to prevent fire hazards and overheating.
- Check all electrical wiring and connections for damage. Keep the battery terminals clean and tight. Repair or replace any damaged part.
- Check fuel and hydraulic tubes, hoses and fittings for damage and leakage. Never use open flame or bare skin to check for leaks. Tighten or replace any parts that show leakage. Always clean fluid spills. Do not use gasoline or diesel fuel for cleaning parts. Use commercial nonflammable solvents.
- Do not use ether or starting fluids on any engine that has glow plugs. These starting aids can cause explosion and injure you or bystanders.
- Always clean the machine, disconnect the battery, and disconnect the wiring from the controllers (if equipped) before welding. Cover rubber hoses, battery and all other flammable parts. Keep a fire extinguisher near the machine when welding. Have good ventilation when grinding or welding painted parts. Wear dust mask when grinding painted parts. Toxic dust or gas can be produced.
- Stop the engine and let it cool before adding fuel. No smoking!

- Use the procedure in the Operation & Maintenance Manual for connecting the battery and for jump starting.
- Use the procedure in the Operation & Maintenance Manual for cleaning the spark arrestor muffler (if equipped).

Figure 1

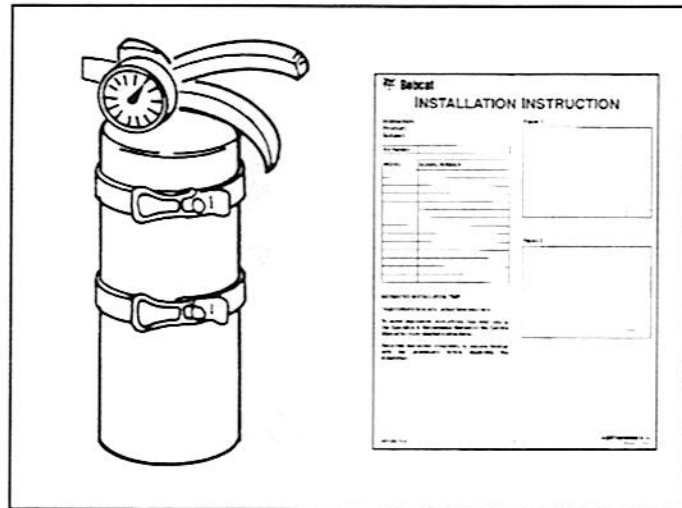

- Know where fire extinguishers and first aid kits are located and how to use them. Fire extinguishers are available from your Bobcat dealer

[Figure 1]

PUBLICATIONS AND TRAINING RESOURCES

The following publications are also available for your Bobcat Attachment. You can order from your Bobcat dealer.

For the latest information on Bobcat products and the Bobcat Company, visit our web site at www.bobcat.com



OPERATION & MAINTENANCE MANUAL

6904968

Complete instructions on the correct operation and the routine maintenance of the Bobcat Attachment.



SERVICE MANUAL

6902771

Complete instructions on the correct operation and the routine maintenance of the Bobcat Attachment.

OPERATING INSTRUCTIONS

DAILY INSPECTION	OI-3
Bob-Tach	OI-3
Chain Tension	OI-5
Checking The Cushion Safety Valve	OI-6
Drop Hammer Mounting Frame	OI-3
OPERATING PROCEDURE WITH LOADERS	OI-6
Approved Loader Models & Requirements	OI-6
Entering And Exiting The Loader	OI-6
Hydraulic Quick Couplers	OI-13
Installation	OI-8
Operation With Loaders	OI-14
Removal	OI-15
LIFTING THE DROP HAMMER	OI-17
Procedure	OI-17
TRANSPORT LOCK	OI-16
Operation	OI-16
TRANSPORTING THE DROP HAMMER ON A TRAILER	OI-17
Fastening the Drop Hammer to the Transport Vehicle	OI-17
TRANSPORTING THE DROP HAMMER AND MACHINE ON A TRAILER	OI-18
Loading And Fastening	OI-18

**OPERATING
INSTRUCTIONS**

DAILY INSPECTION

Drop Hammer Mounting Frame

Figure OI-1

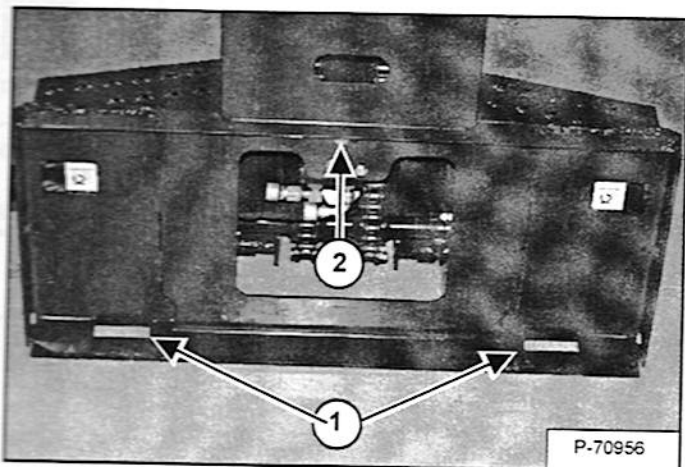

Inspect the Bob-Tach wedge mount (Item 1), mounting flange (Item 2) [Figure OI-1] and all welds on the Drop Hammer mount for wear and damage each time the Drop Hammer is removed from the loader.

Bob-Tach

Hand Lever Bob-Tach

WARNING

Bob-Tach wedges must extend through the holes in attachment. Levers must be fully down and locked. Failure to secure wedges can allow attachment to come off and cause injury or death.

W-2102-0588

Figure OI-2

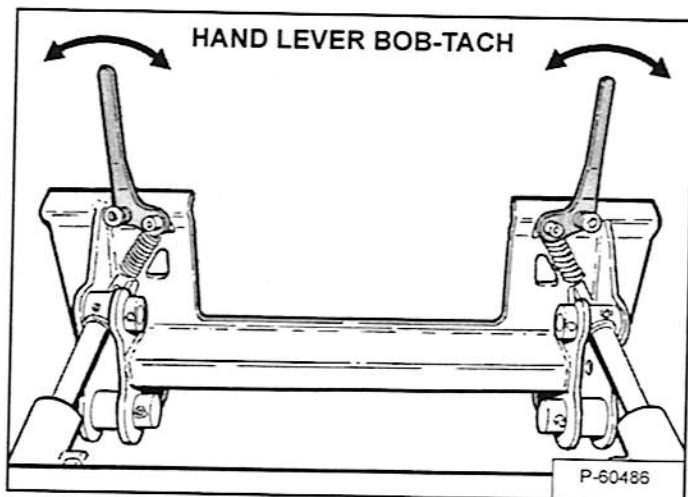

Move the Bob-Tach levers to engage and disengage the wedges [Figure OI-2]. The levers and wedges must move freely.

Figure OI-3

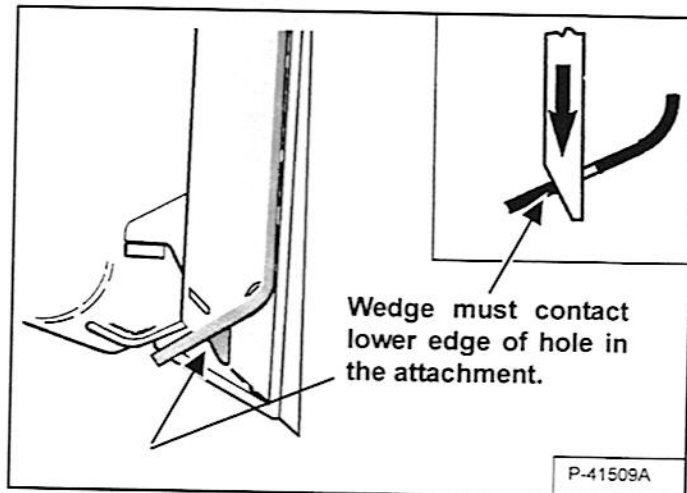

The wedges must extend through the holes in the attachment mounting frame [Figure OI-3].

If the wedge does not contact the lower edge of the hole [Figure OI-3], the attachment will be loose and can come off the Bob-Tach.

DAILY INSPECTION (CONT'D)

Bob-Tach (Cont'd)

Hand Lever Bob-Tach (Cont'd)

Figure OI-4

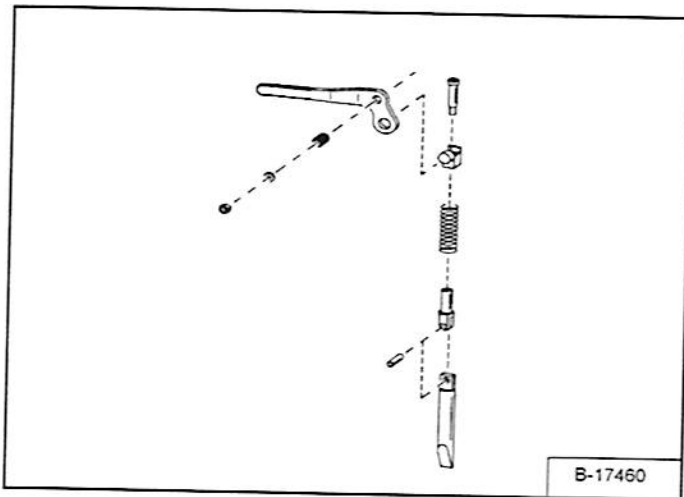

Inspect the mounting frame on the attachment and the Bob-Tach, linkages and wedges for excessive wear or damage [Figure OI-4]. Replace any parts that are damaged, bent or missing. Keep all fasteners tight.

Look for cracked welds. Contact your Bobcat dealer for repair or replacement parts.

Lubricate the wedges. (See the correct loader Operation & Maintenance Manual for *LUBRICATION OF THE BOBCAT LOADER.*)

Power Bob-Tach Option

! WARNING

Bob-Tach wedges must extend through the holes in attachment. Levers must be fully down and locked. Failure to secure wedges can allow attachment to come off and cause injury or death.

W-2102-0588

Figure OI-5

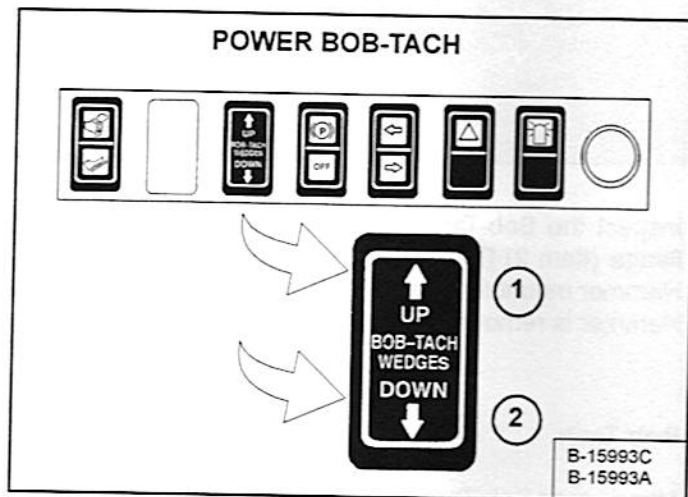
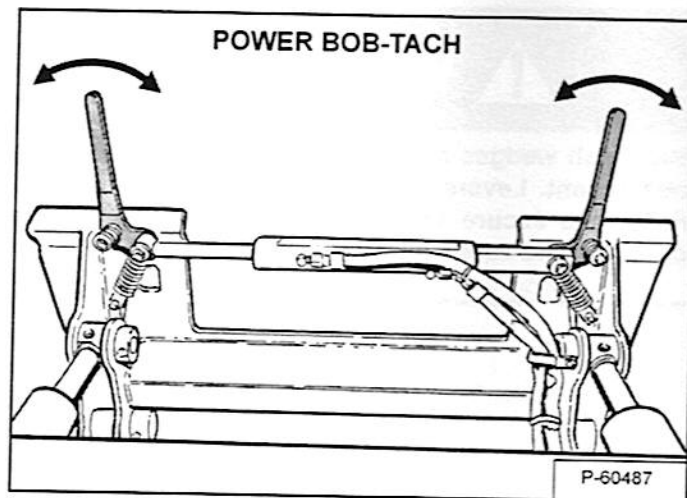

Figure OI-6



Push and hold the BOB-TACH WEDGES UP switch (Item 1) until the wedges are fully raised. Push and hold the BOB-TACH WEDGES DOWN switch (Item 2) [Figure OI-5] until the wedges are fully lowered.

The levers and wedges must move freely [Figure OI-6].

DAILY INSPECTION (CONT'D)

Bob-Tach (Cont'd)

Power Bob-Tach Option (Cont'd)

Figure OI-7

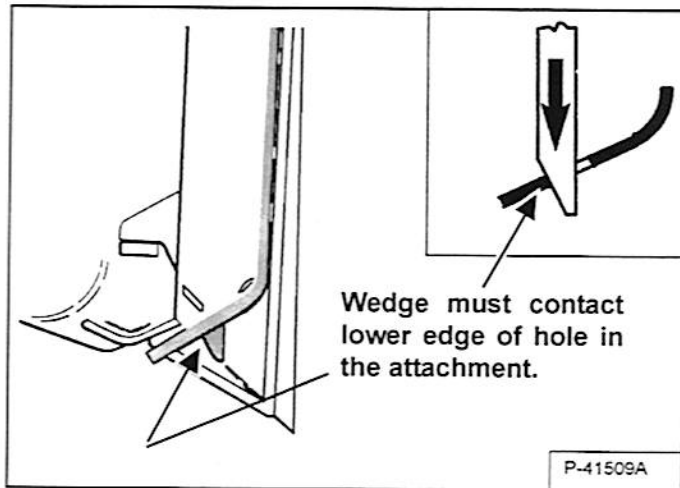

The wedges must extend through the holes in the attachment mounting frame [Figure OI-7].

If the wedge does not contact the lower edge of the hole [Figure OI-7], the attachment will be loose and can come off the Bob-Tach.

Figure OI-8

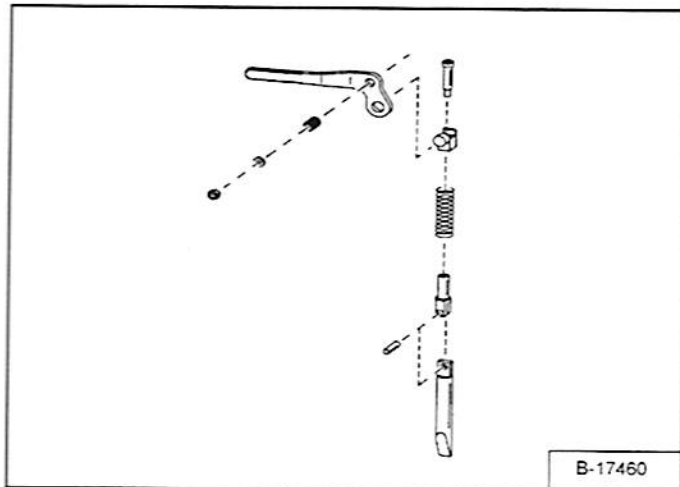

Inspect the mounting frame on the attachment and the Bob-Tach, linkages and wedges for excessive wear or damage [Figure OI-8]. Replace any parts that are damaged, bent or missing. Keep all fasteners tight.

Look for cracked welds. Contact your Bobcat dealer for repair or replacement parts.

Lubricate the wedges. (See the correct loader Operation & Maintenance Manual for *LUBRICATION OF THE BOBCAT LOADER*.)

Chain Tension

! WARNING

AVOID INJURY OR DEATH

Keep shields in place during operation.

STOP engine and disconnect auxiliary hydraulic hoses before servicing attachment.

W-2549-0107

Figure OI-9

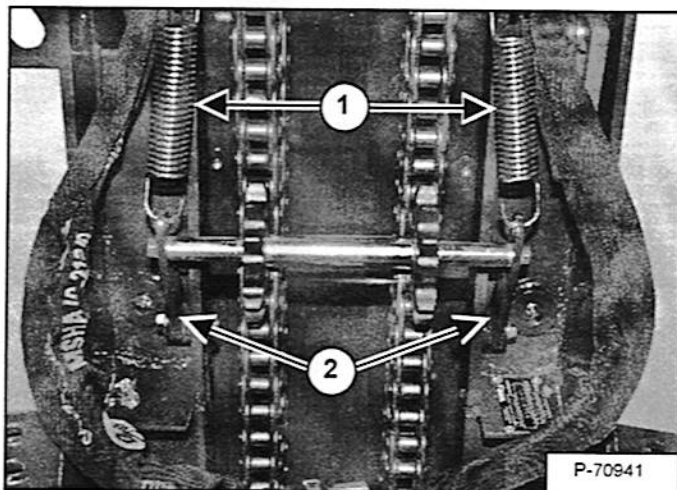

Raise cover and inspect the chain. The chain must be held tight with the tensioner springs (Item 1) [Figure OI-9]. If the chain is worn beyond tensioner ability, replace chain.

Inspect the tensioner springs (Item 1) [Figure OI-9]. Replace tensioner springs if broken.

Inspect the tensioner arms (Item 2) [Figure OI-9]. The tensioner arms must move freely.

DAILY INSPECTION (CONT'D)

Checking The Cushion Safety Valve

NOTE: Cushioned Safety Valve allows the weight to slowly lower if the hydraulic oil flow is stopped before the weight reaches full dropping height.

Figure OI-10

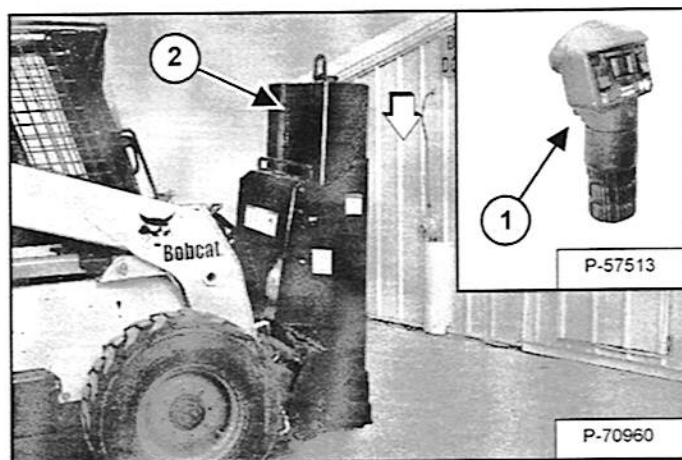

Engage auxiliary hydraulics.

Press the front switch (Item 1) on the right steer lever to start the Drop Hammer. When the weight (Item 2) begins to raise, press the switch (Item 1) [Figure OI-10] a second time stopping the hydraulic flow to the Drop Hammer. The weight should slowly lower to the ground.

NOTE: If the Cushioned Safety Valve does not operate correctly, see your Bobcat dealer for service.

OPERATING PROCEDURE WITH LOADERS

Approved Loader Models & Requirements

Figure OI-11

LOADER MODEL	DROP HAMMER
S175	X
S185	X
T180	X
T190	X
S205	X
S220	X
S250	X
T250	X
S300	X
A300	X
T300	X
S330	X

The chart [Figure OI-11] shows the approved loader models for the Drop Hammer.

The warranty is void if this attachment is used on a non-approved carrier. See your Bobcat dealer for an updated list of approved carriers.

Figure OI-12

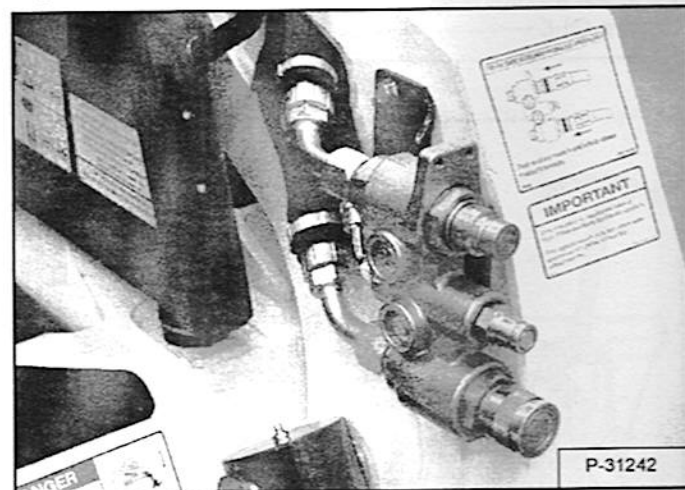

The loader must be equipped with the front auxiliary hydraulics [Figure OI-12] for proper operation of the Drop Hammer. See your Bobcat Loader dealer for available kits for your model loader.

The warranty is void if this attachment is used on a non-approved carrier. See your Bobcat dealer for an updated list of approved carriers.

OPERATING PROCEDURE WITH LOADERS (CONT'D)

Entering And Exiting The Loader

WARNING

Before you leave the operator's seat:

- Lower the lift arms, put the attachment flat on the ground.
- Stop the engine.
- Engage the parking brake.
- Raise seat bar.
- (Foot Pedal Controls) Move pedals until both lock.
- (Advanced Control System-ACS) Move the hydraulic controls to the **NEUTRAL POSITION** to make sure that both lift and tilt functions are deactivated.

The seat bar system must deactivate the lift and tilt control functions when the seat bar is up. Service the system if hand controls do not deactivate.

- (Selectable Joystick Controls-SJC) Move the joysticks to the **NEUTRAL POSITION** to make sure that travel and hydraulic functions are deactivated.

The seat bar system must deactivate these functions when the seat bar is up. Service the system if controls do not deactivate.

W-2463-0603

Figure OI-13



Use the Drop Hammer steps, grab handles (on cab and Drop Hammer) to enter and exit the loader [Figure OI-13].

Figure OI-14



Get in the operator seat. Fasten the seat belt and adjust it so the buckle is centered between your hips [Figure OI-14].

Figure OI-15



Lower the seat bar [Figure OI-15].

OPERATING PROCEDURE WITH LOADERS (CONT'D)

Installation

Hand Lever Bob-Tach

NOTE: The illustrations and instructions provided explain how to install a bucket attachment on to a machine. Follow these same instructions if you are installing different attachments such as a grapple, tiller, combo bucket, etc.

The attachment mounting frame for the attachment has a top flange that is designed to receive the top edge of the Bob-Tach and the lower part of the frame is designed to receive the Bob-Tach wedges.

WARNING

Warnings on the machine and in the manuals are for your safety. Failure to obey warnings can cause injury or death.

W-2044-1285

WARNING

Before you leave the operator's position.

- Lower the lift arm(s) fully.
- Stop the engine and engage the parking brake.
- Move all pedals, handles, joysticks, and other controls until they are LOCKED or in the NEUTRAL position.

SEE THE MACHINE OPERATION & MAINTENANCE MANUAL FOR MORE INFORMATION.

W-2500-0404

Always inspect the machine's Bob-Tach and the attachment mounting frame before installation. (See Machine's Operation & Maintenance Manual and Inspection of this manual.) (See DAILY INSPECTION on Page OI-3.)

WARNING

Bob-Tach levers have spring tension. Hold lever tightly and release slowly. Failure to obey warning can cause injury.

W-2054-1285

Figure OI-16

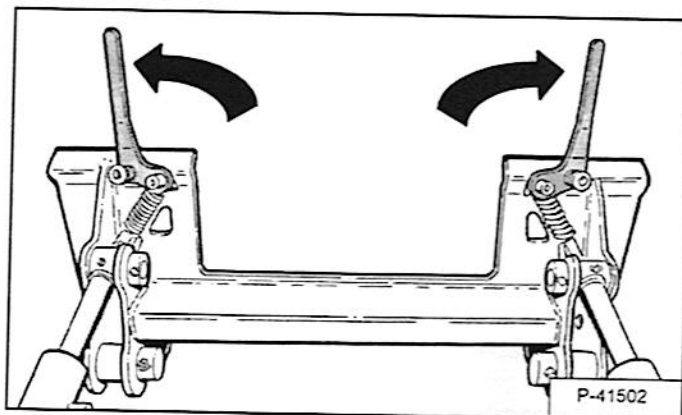

Pull the Bob-Tach levers all the way up [Figure OI-16].

Move to the operator's position. For ROPS equipped machines, fasten seat belt.

Start the engine and release the parking brake.

Figure OI-17

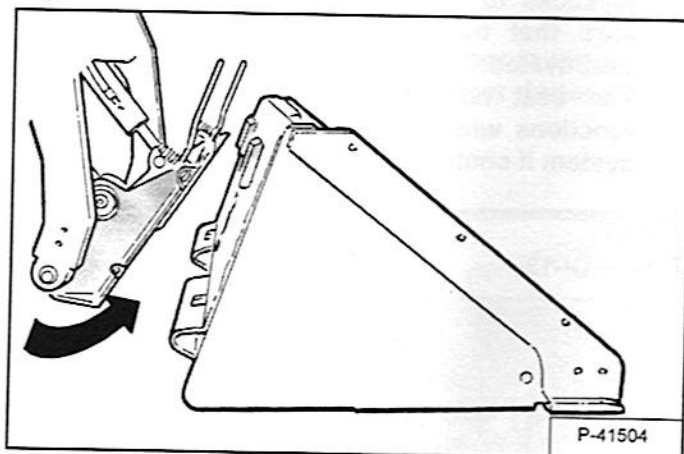

Tilt the Bob-Tach forward slightly.

Drive the machine slowly forward until the top edge of the Bob-Tach is completely under the top flange of the attachment mounting plate [Figure OI-17].

NOTE: Be sure the Bob-Tach levers do not hit the attachment.

OPERATING PROCEDURE LOADERS (CONT'D)

Installation (Cont'd)

Hand Lever Bob-Tach (Cont'd)

Figure OI-18

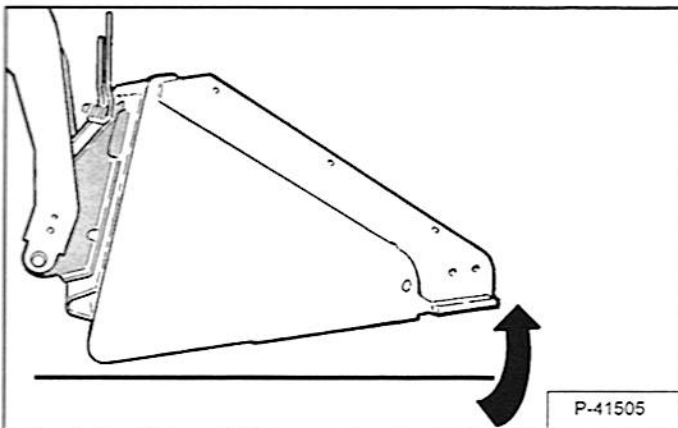

Tilt the Bob-Tach backward until the attachment is slightly off the ground [Figure OI-18]. This will cause the attachment frame to fit up against the front of the Bob-Tach.

Stop the engine, engage the parking brake and exit the machine.

WARNING

Before you leave the operator's position.

- Lower the lift arm(s) fully.
- Stop the engine and engage the parking brake.
- Move all pedals, handles, joysticks, and other controls until they are LOCKED or in the NEUTRAL position.

SEE THE MACHINE OPERATION & MAINTENANCE MANUAL FOR MORE INFORMATION.

W-2500-0404

Figure OI-19

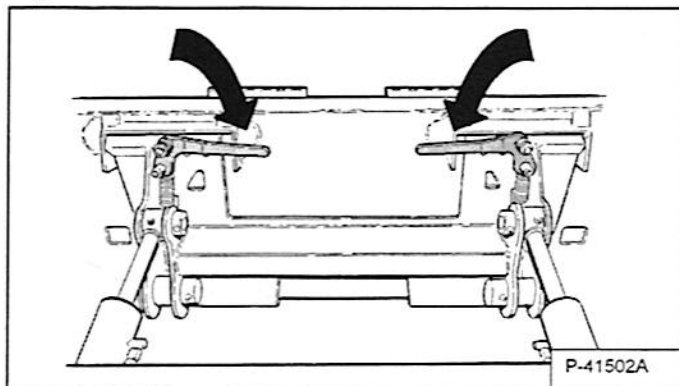

Push down on the Bob-Tach levers until they are fully engaged in the locked position [Figure OI-19].

Figure OI-20

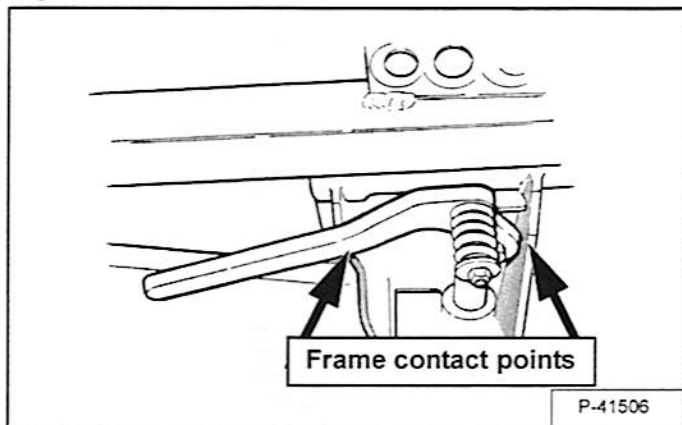

The levers must contact the frame as shown when locked [Figure OI-20].

If the levers do not engage in the locked position, see your Bobcat dealer for maintenance.

Installation (Cont'd)

Hand Lever Bob-Tach (Cont'd)

! WARNING

Bob-Tach wedges must extend through the holes in attachment. Levers must be fully down and locked. Failure to secure wedges can allow attachment to come off and cause injury or death.

W-2102-0588

Figure OI-21

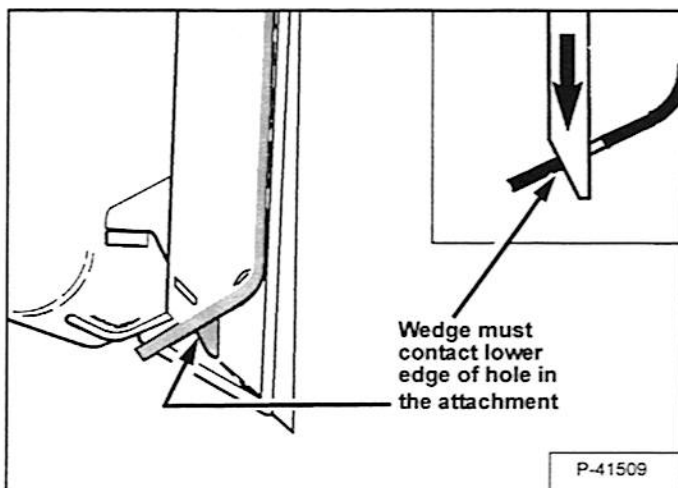

The wedges must extend through the holes in the mounting frame of the attachment, securely fastening the attachment to the Bob-Tach [Figure OI-21].

! WARNING

Warnings on the machine and in the manuals are for your safety. Failure to obey warnings can cause injury or death.

W-2044-1285

! WARNING

Before you leave the operator's seat:

- Lower the lift arms, put the attachment flat on the ground.
- Stop the engine.
- Engage the parking brake.
- Raise seat bar.
- (Foot Pedal Controls) Move pedals until both lock.
- (Advanced Control System-ACS) Move the hydraulic controls to the NEUTRAL POSITION to make sure that both lift and tilt functions are deactivated.
- (Selectable Joystick Controls-SJC) Move the joysticks to the NEUTRAL POSITION to make sure that travel and hydraulic functions are deactivated.

The seat bar system must deactivate the lift and tilt control functions when the seat bar is up. Service the system if hand controls do not deactivate.

The seat bar system must deactivate these functions when the seat bar is up. Service the system if controls do not deactivate.

W-2463-0603

Enter the machine.

Fasten seat belt, lower the seat bar, start the engine, and release the parking brake.

OPERATING PROCEDURE LOADERS (CONT'D)

Installation (Cont'd)

Power Bob-Tach Option (Cont'd)

Figure OI-22

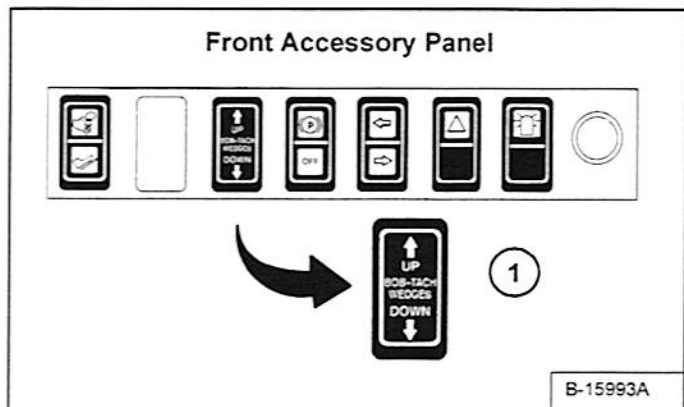
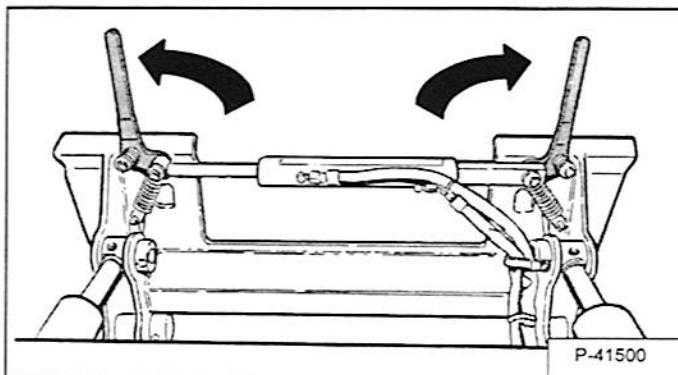
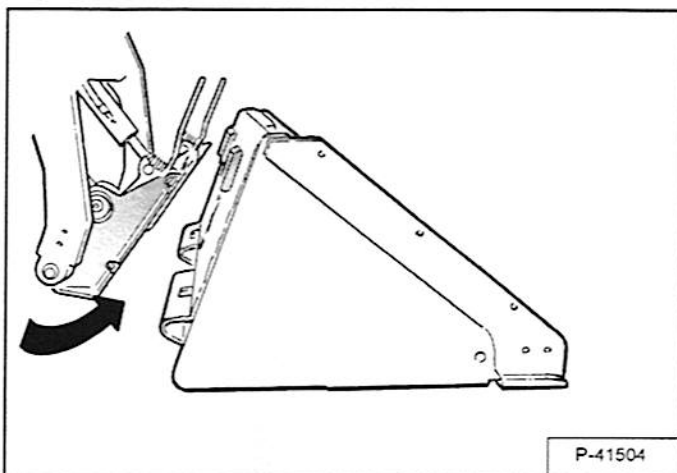

Figure OI-23



Push and hold the BOB-TACH WEDGES UP switch (Item 1) [Figure OI-22] until the levers are fully raised [Figure OI-23].

Figure OI-24



Tilt the Bob-Tach forward slightly.

Drive the machine forward until the top edge of the Bob-Tach is completely under the top flange of the attachment mounting plate [Figure OI-24].

NOTE: Be sure the Bob-Tach levers do not hit the attachment.

Figure OI-25

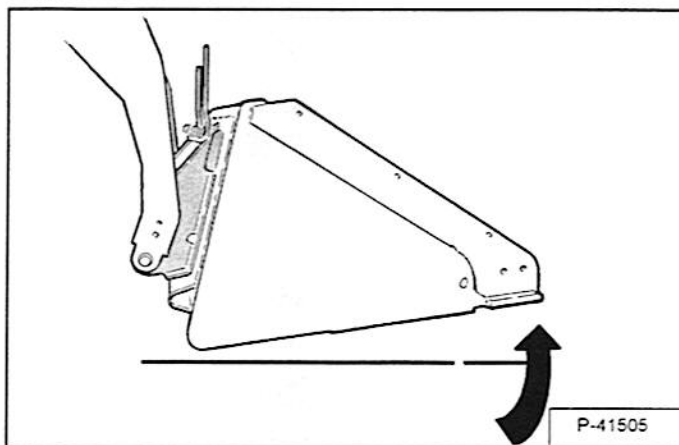

Tilt the Bob-Tach backward until the attachment is slightly off the ground [Figure OI-25].

OPERATING PROCEDURE LOADERS (CONT'D)

Installation (Cont'd)

Power Bob-Tach Option (Cont'd)

Figure OI-26

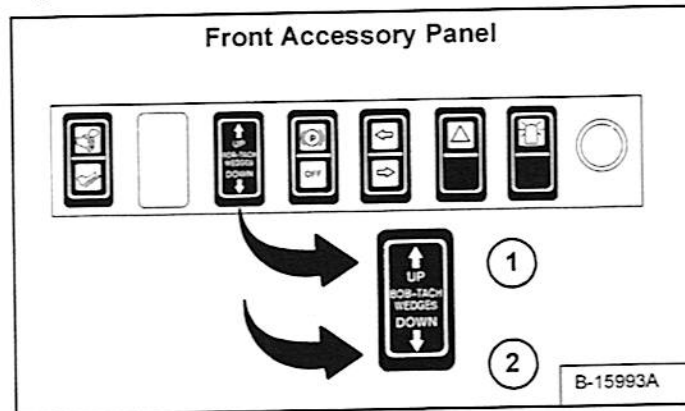

NOTE: The Power Bob-Tach system has continuous pressurized hydraulic oil to keep the wedges in the engaged position and prevent attachment disengagement. Because the wedges can slowly lower, the operator may need to reactivate the switch (BOB-TACH WEDGES UP) to be sure both wedges are fully raised before installing the attachment.

Push and hold the BOB-TACH WEDGES UP switch (Item 1) [Figure OI-26] to ensure the wedges are fully raised.

Figure OI-27

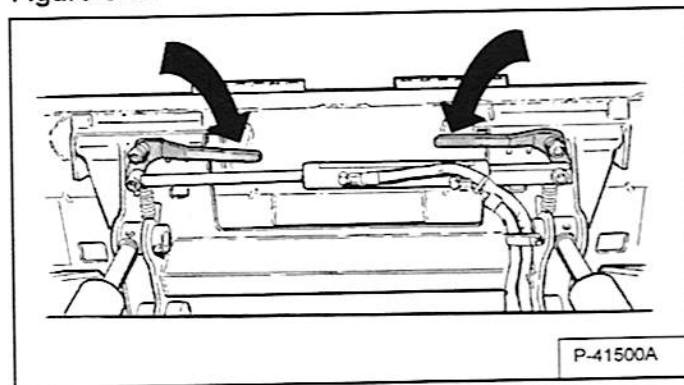

Push and hold the BOB-TACH WEDGES DOWN switch (Item 2) [Figure OI-26] until the levers are fully engaged [Figure OI-27] and the wedges are fully extended through the mounting frame holes.

Figure OI-28

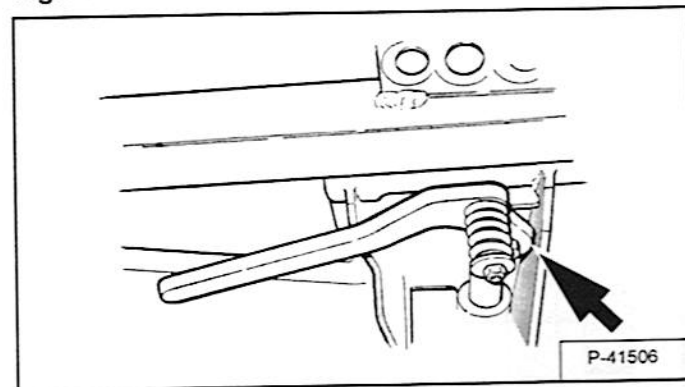

The levers must contact the frame [Figure OI-28] as shown when locked.

If the levers do not engage in the locked position, see your Bobcat dealer for maintenance.

WARNING

Bob-Tach wedges must extend through the holes in attachment. Levers must be fully down and locked. Failure to secure wedges can allow attachment to come off and cause injury or death.

W-2102-0588

Figure OI-29

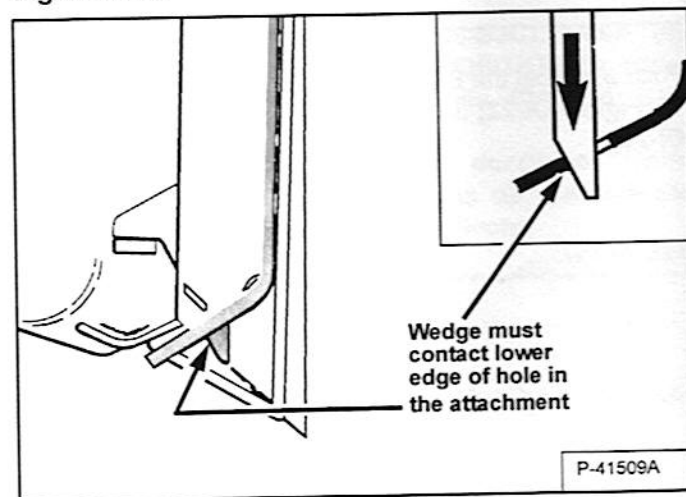

The wedges must extend through the holes in the mounting frame of the attachment, securely fastening the attachment to the Bob-Tach [Figure OI-29].

Hydraulic Quick Couplers

! WARNING

AVOID BURNS

Hydraulic fluid, tubes, fittings and quick couplers can get hot when running machine and attachments. Be careful when connecting and disconnecting quick couplers.

W-2220-0396

IMPORTANT

Contain and dispose of any oil leakage in an environmentally safe manner.

I-2066-0395

IMPORTANT

Thoroughly clean the quick couplers before making connections. Dirt can quickly damage the system.

I-2178-0698

New attachments and new machines are factory equipped with flush face couplers. If installing the attachment on a loader equipped with poppet style couplers on either the loader or the attachment, the couplers will have to be changed to match the other. See your Bobcat dealer for parts information.

NOTE: Make sure the quick couplers are fully engaged. If the quick couplers do not fully engage, check to see that the couplers are the same size and type. (See the correct Machine Operation & Maintenance Manual for the proper procedure to relieve hydraulic pressure.)

Figure OI-30

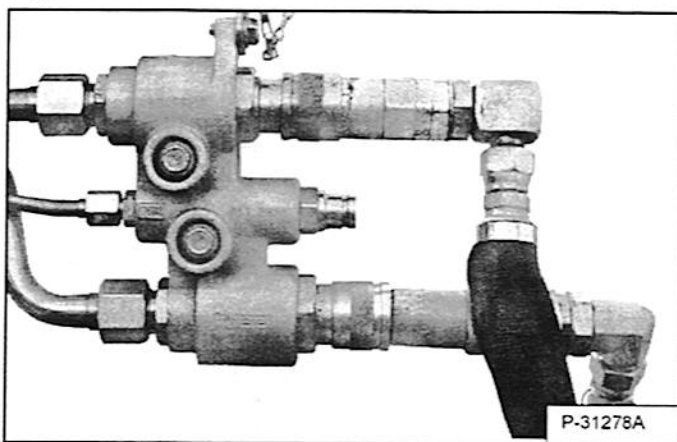

To Connect

Install the male coupler into the female coupler. Full connection is made when the ball release sleeve slides forward on the female coupler.

For First Time Installation

With the loader engine off, connect the attachment couplers to the loader couplers. Check the attachment hoses so they are not twisted and they route to the loader without contacting any moving parts. If necessary, loosen the hoses and reroute the hoses as needed. Tighten all connections before starting the loader.

To Disconnect

Relieve hydraulic pressure. Push the couplers together, hold for five seconds. Retract the sleeve on the female coupler until the couplers disconnect.

OPERATING PROCEDURE WITH LOADERS (CONT'D)

Operation With Loaders

Unlock the Transport Lock. (See Operation on Page OI-16.)

Move to the operator's position, fasten seat belt, lower the seat bar, start the engine and release the parking brake.

WARNING

AVOID INJURY OR DEATH

- Personnel must keep at least 10 feet (3 m) away from attachment and machine when operating.
- Never leave operator seat when the engine is running.

W-2566-0207

WARNING

AVOID INJURY OR DEATH

Keep shields in place during operation.

STOP engine and disconnect auxiliary hydraulic hoses before servicing attachment.

W-2549-0107

Figure OI-31



Position the Drop Hammer on surface to be broken [Figure OI-31].

The Drop Hammer should be vertical to the surface to be broken and skid shoes firmly on the ground.

NOTE: Make sure there is adequate clearance above the Drop Hammer for the weight to be lifted during operation. For height with weight fully raised (See SPECIFICATIONS on Page SPEC-3.)

NOTE: Loader arms may be operated in the float position, this will decrease skid shoe wear.

Figure OI-32

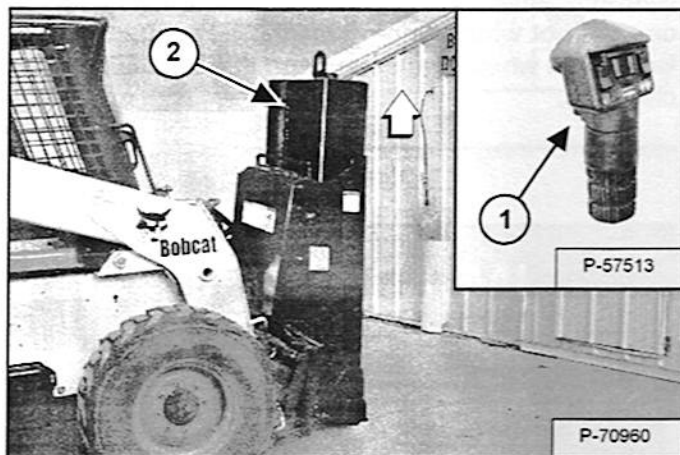

Press the front switch (Item 1) [Figure OI-31] on the right steer lever to start the Drop Hammer. Press the switch a second time to stop the Drop Hammer.

Engage the auxiliary hydraulics and begin demolition of surface.

NOTE: During operation the Drop Hammer will be lifted and dropped approximately 20 times per minute.

IMPORTANT

Operating the Drop Hammer on concrete material less than 4 inches (10 cm) thick, or when raised off the ground, can cause frame damage.

I-2242-0107

Allow hammer (Item 2) [Figure OI-32] to cycle until desired demolition is obtained. Thinner concrete 0 - 6 in. (0 - 15 cm) will require 1 hammer blow, thicker concrete 8 in. + (20 cm) may require multiple blows. Slide Drop Hammer ONLY when the weight is in the raise cycle.

NOTE: If the auxiliary hydraulics are shut off during the raise cycle, the weight will slowly lower down.

OPERATING PROCEDURE LOADERS (CONT'D)

Removal

Hand Lever Bob-Tach

Figure OI-33

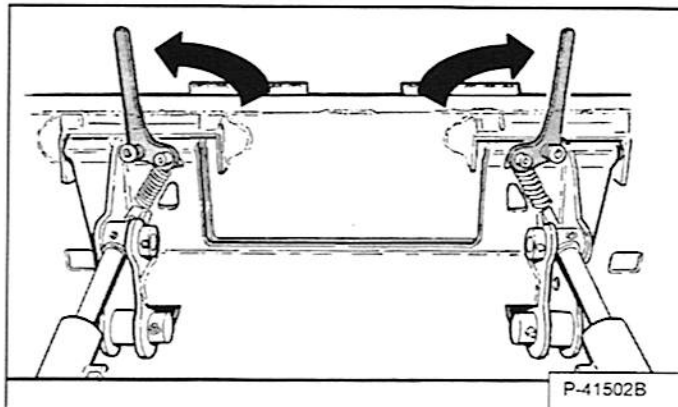

Pull the Bob-Tach levers all the way up [Figure OI-33].

Move to operator's position. For ROPS equipped machines, fasten seat belt.

Start the engine and release the parking brake.

Power Bob-Tach Option

Enter the machine.

Fasten seat belt, lower the seat bar, start the engine and release the parking brake.

Figure OI-34

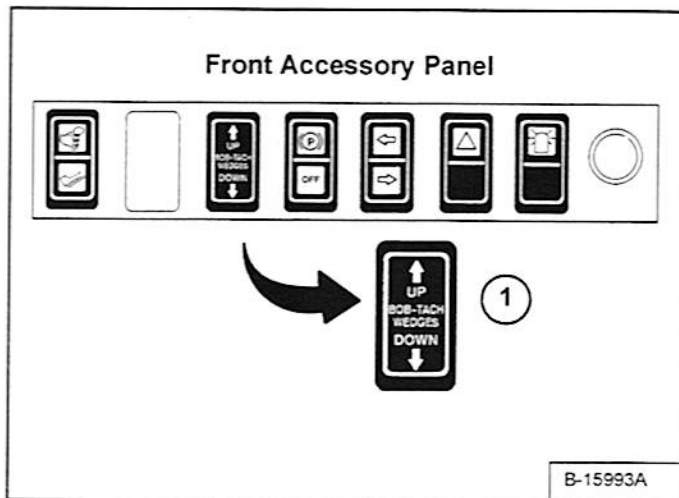

Push and hold the BOB-TACH WEDGES UP switch (Item 1) [Figure OI-34] until the levers and wedges are fully raised.

All Loaders

Figure OI-35

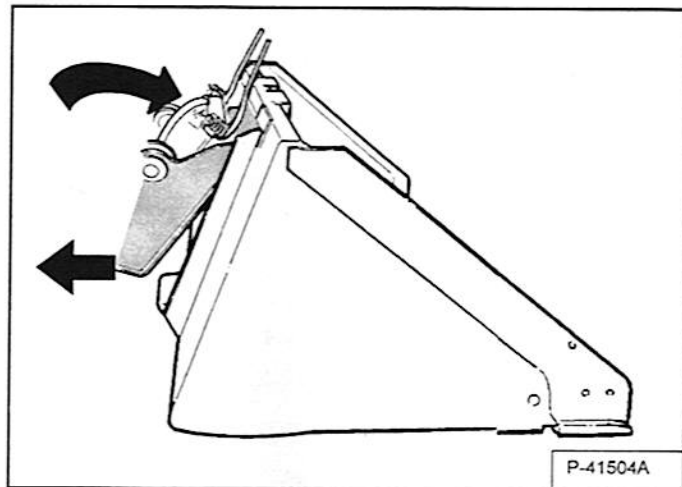

Tilt the Bob-Tach forward while backing the machine away from the attachment [Figure OI-35].

NOTE: In muddy conditions or to prevent the attachment from freezing to the ground, put the attachment on planks or blocks before removing the attachment from the machine.

TRANSPORT LOCK

Operation

⚠ WARNING

AVOID INJURY OR DEATH

Always install the Transport Lock when transporting the drop hammer. Failure to obey this instruction could cause the weight to shift, causing serious injury, death or property damage.

W-2489-1203

Figure OI-36

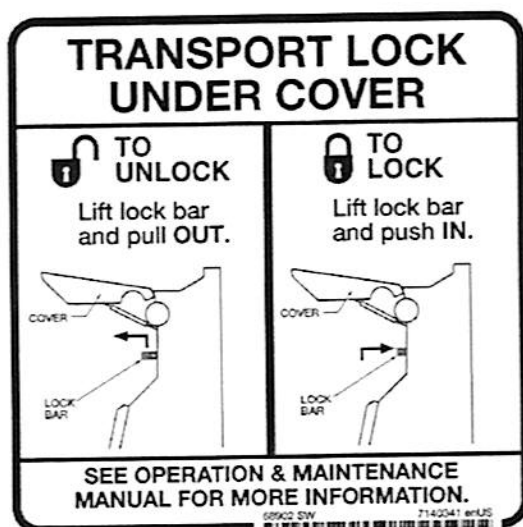
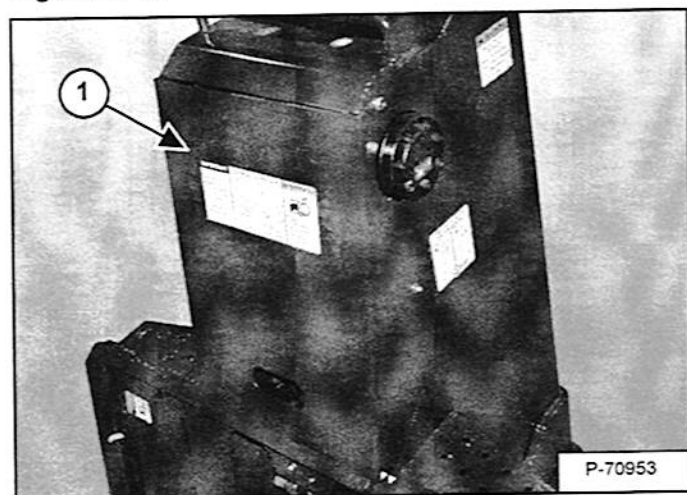

Figure OI-37



Raise cover (Item 1) [Figure OI-37].

To Unlock

Figure OI-38

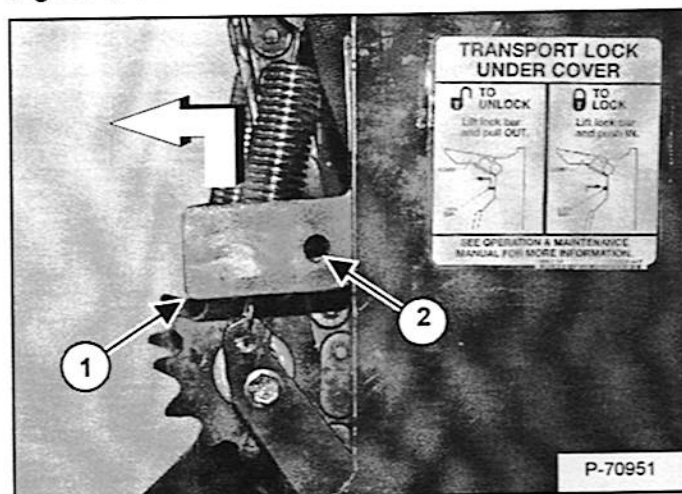

Lift lock bar (Item 1) [Figure OI-38] and pull OUT.

When the hole (Item 2) [Figure OI-38] in the lock bar is visible, the Transport Lock is unlocked.

To Lock

Figure OI-39

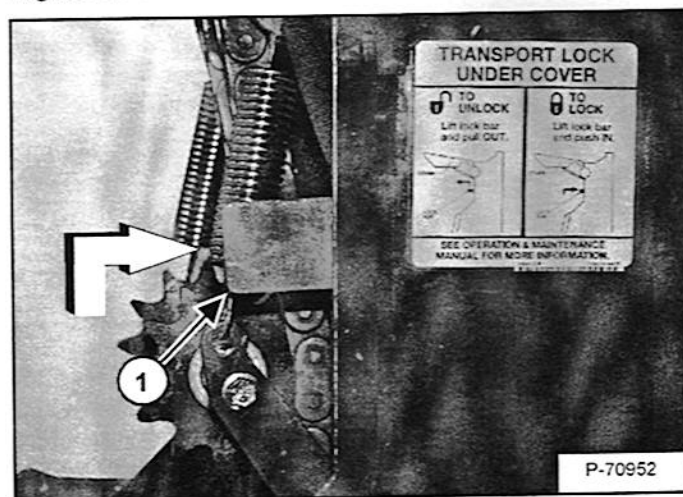

Lift lock bar (Item 1) [Figure OI-39] and push IN.

Make sure the lock bar is fully seated.

Note: If the lock bar is not fully seated in either the locked or unlocked position, the cover will not fully close.

Close cover (Item 1) [Figure OI-39].

LIFTING THE DROP HAMMER

Procedure

Figure OI-40

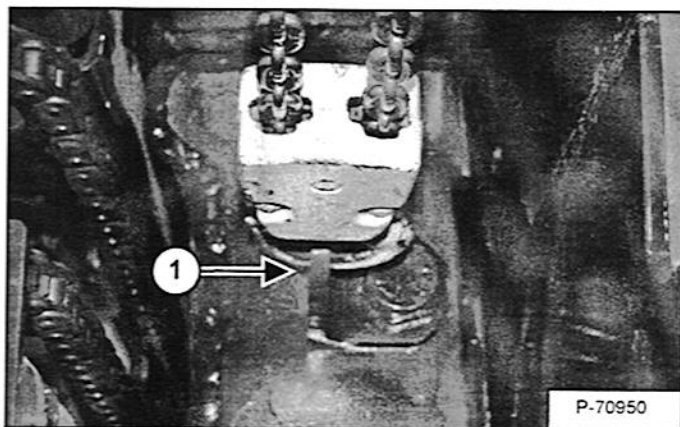
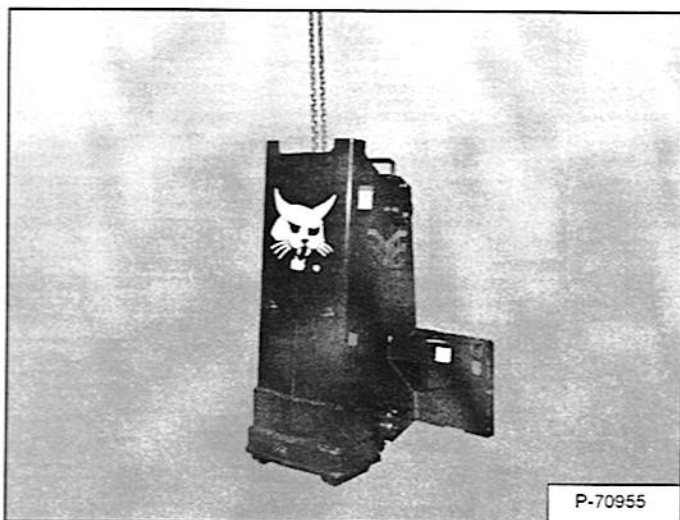

Figure OI-41



NOTE: Use chains that are in good condition and of adequate size to lift the attachment.

Engage the Transport Lock. (See TRANSPORT LOCK on Page OI-16.)

With the Transport Lock in the locked position, fasten a chain (Item 1) [Figure OI-40] to the weight.

Lift the Drop Hammer [Figure OI-41].

TRANSPORTING THE DROP HAMMER ON A TRAILER

Fastening the Drop Hammer to the Transport Vehicle

Engage the Transport Lock. (See TRANSPORT LOCK on Page OI-16.)

Figure OI-42

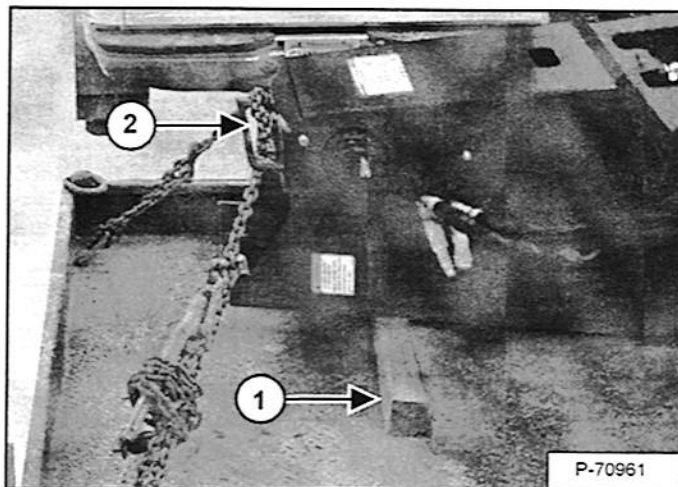

Place the Drop Hammer face down on a block (Item 1) [Figure OI-42], this will allow the operator to install the attachment from the side of the transport vehicle.

Fasten a chain (Item 2) [Figure OI-42] around the handle of the Drop Hammer and fasten each end of the chain to the transport vehicle.

Figure OI-43

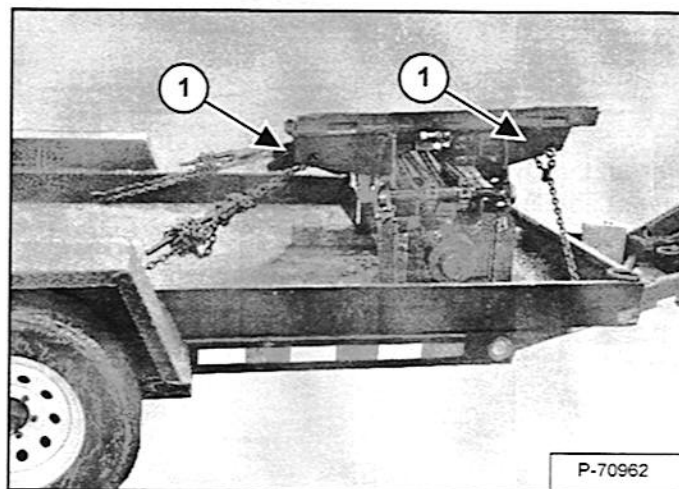

Fasten chains (Item 1) [Figure OI-43] to the tie down locations on the Drop Hammer steps and fasten chains to the transport vehicle.

Use chain binders to prevent the Drop Hammer from moving during transport.

TRANSPORTING THE DROP HAMMER AND MACHINE ON A TRAILER

Loading And Fastening

Engage the Transport Lock. (See TRANSPORT LOCK on Page OI-16.)

Loading And Unloading

Load the Drop Hammer towards the front of the transport vehicle.

See the correct Machine Operation & Maintenance Manual to properly load and unload the machine on a transport vehicle.

Fastening the Drop Hammer and machine to the transport vehicle

Figure OI-44

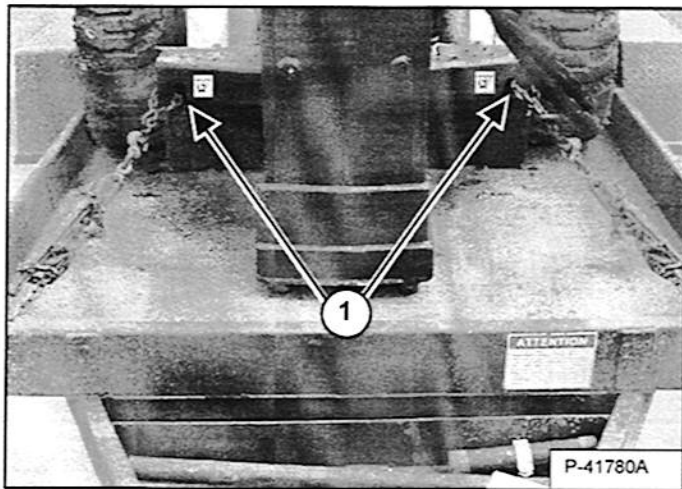

Fasten the chains to the Drop Hammer (Item 1) [Figure OI-44] and fasten each end of the chain to the transport vehicle.

See the correct machine Operation & Maintenance Manual to properly chain the machine to the transport vehicle.

PREVENTIVE MAINTENANCE

LUBRICATION	PM-5
Lubrication Points	PM-5
SERVICE SCHEDULE	PM-4
TROUBLESHOOTING	PM-3

**PREVENTIVE
MAINTENANCE**

TROUBLESHOOTING

PROBLEM	CAUSE	CORRECTION
Loose chain.	Broken spring.	Replace spring.
	Worn chain.	Replace chain.
Excessive wear to chain catch, weight and housing.	Poor lubrication.	Lubricate attachment.
Weight contacts frame when dropped.	Excessively worn tool.	Replace tool.
	Skid shoes not placed firmly on the surface.	Position skid shoes on the surface.
Chain does not engage weight during lift cycle.	Lose or worn chain.	Replace the chain.
	Worn catch.	Replace chain and/or weight catch.

SERVICE SCHEDULE**EVERY 8 HOURS OF OPERATION**

1. Check mounting frame for damage or cracked welds. Replace or repair if necessary.
2. Check chain tension. Replace chain if necessary.
3. Check for damaged or missing decals or shields. Replace if necessary.
4. Lubricate all (6) grease points.
5. Oil chain and catch.

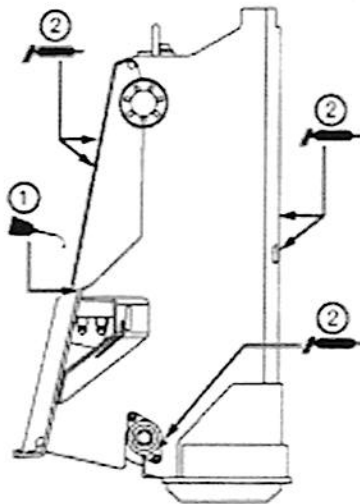

**SEE ATTACHMENT OPERATION & MAINTENANCE
MANUAL FOR MORE INFORMATION**

⚠ WARNING**AVOID INJURY
OR DEATH**

- Keep shields in place during operation.
- STOP engine and disconnect auxiliary hydraulic hoses before servicing attachment.

69902 SW

7137616 enUS

© 2008 Deere & Company. All rights reserved. Deere, the Deere logo, and the Deere name are trademarks of Deere & Company.

LUBRICATION

Lubrication Points

Always use a good quality lithium base multi purpose grease when lubricating the attachment. Apply the lubricant until extra grease shows.

IMPORTANT

Fluid such as engine oil, hydraulic fluid, coolants, grease, etc. must be disposed of in an environmentally safe manner. Some regulations require that certain spills and leaks on the ground must be cleaned in a specific manner. See local, state and federal regulations for the correct disposal.

I-2067-0499

! WARNING

AVOID INJURY OR DEATH

Keep shields in place during operation.

STOP engine and disconnect auxiliary hydraulic hoses before servicing attachment.

W-2549-0107

Lubricate the following six locations on the Drop Hammer every 8 hours:

Figure PM-1

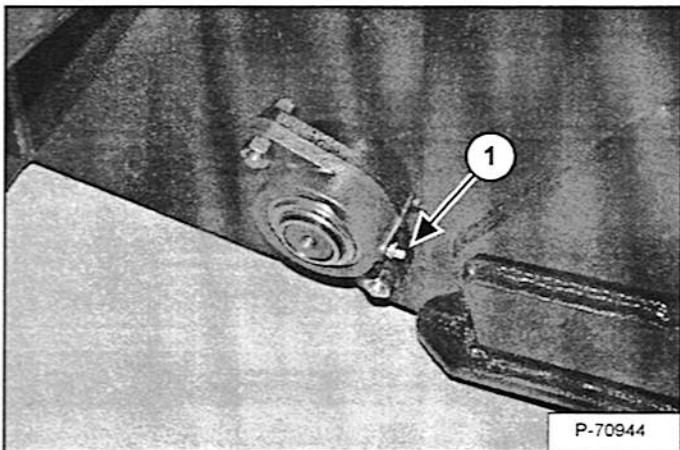

Grease point (Item 1) [Figure PM-1] are located on both sides of the lower sprocket.

Figure PM-2

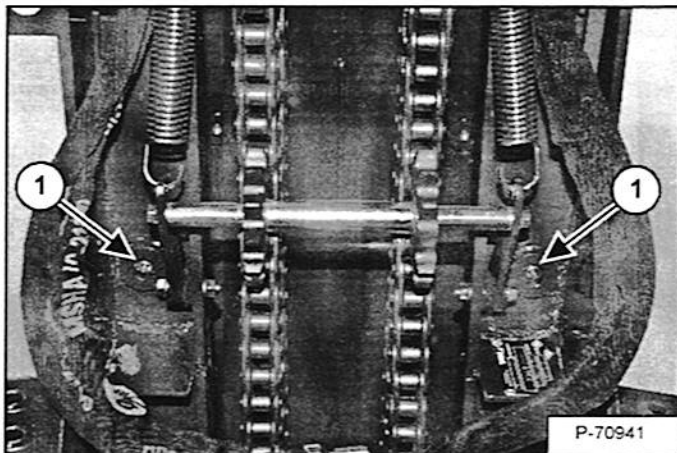

Grease points (Item 1) [Figure PM-2] inside the cover.

Figure PM-3

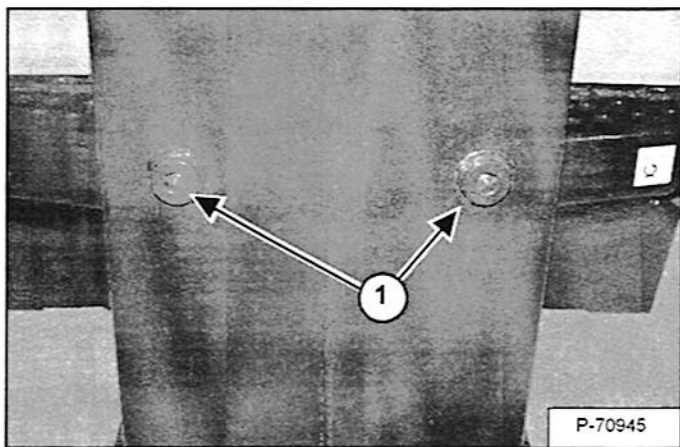

Grease points (Item 1) [Figure PM-3] are located on the front of the weight housing.

LUBRICATION (CONT'D)

Lubrication Points (Cont'd)

NOTE: The following lubrication points are to be oiled, not greased.

Figure PM-4

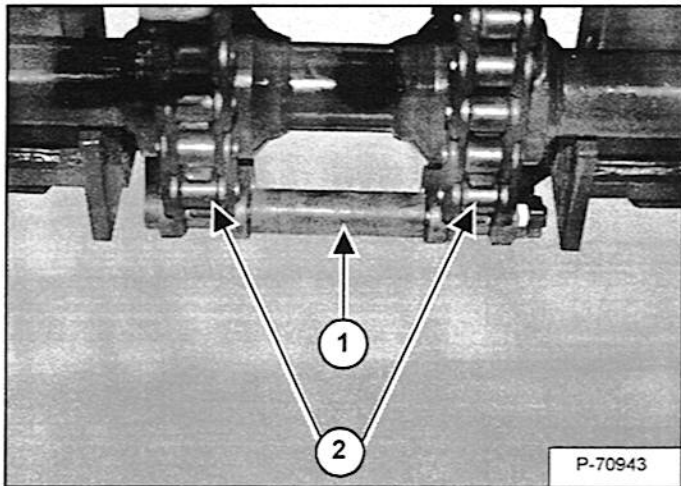

Apply a generous amount of oil to the chain catch (Item 1) and chain (Item 2) [Figure PM-4] every 8 hours of operation.

SPECIFICATIONS

HYDRAULIC SCHEMATIC SPEC-4
SPECIFICATIONS..... SPEC-3

SPECIFICATIONS

SPECIFICATIONS

- All dimensions are shown in inches. Respective metric dimensions are given in millimeters enclosed by parentheses.
- Where applicable, specifications conform to **SAE and ISO** standards and are subject to change without notice.

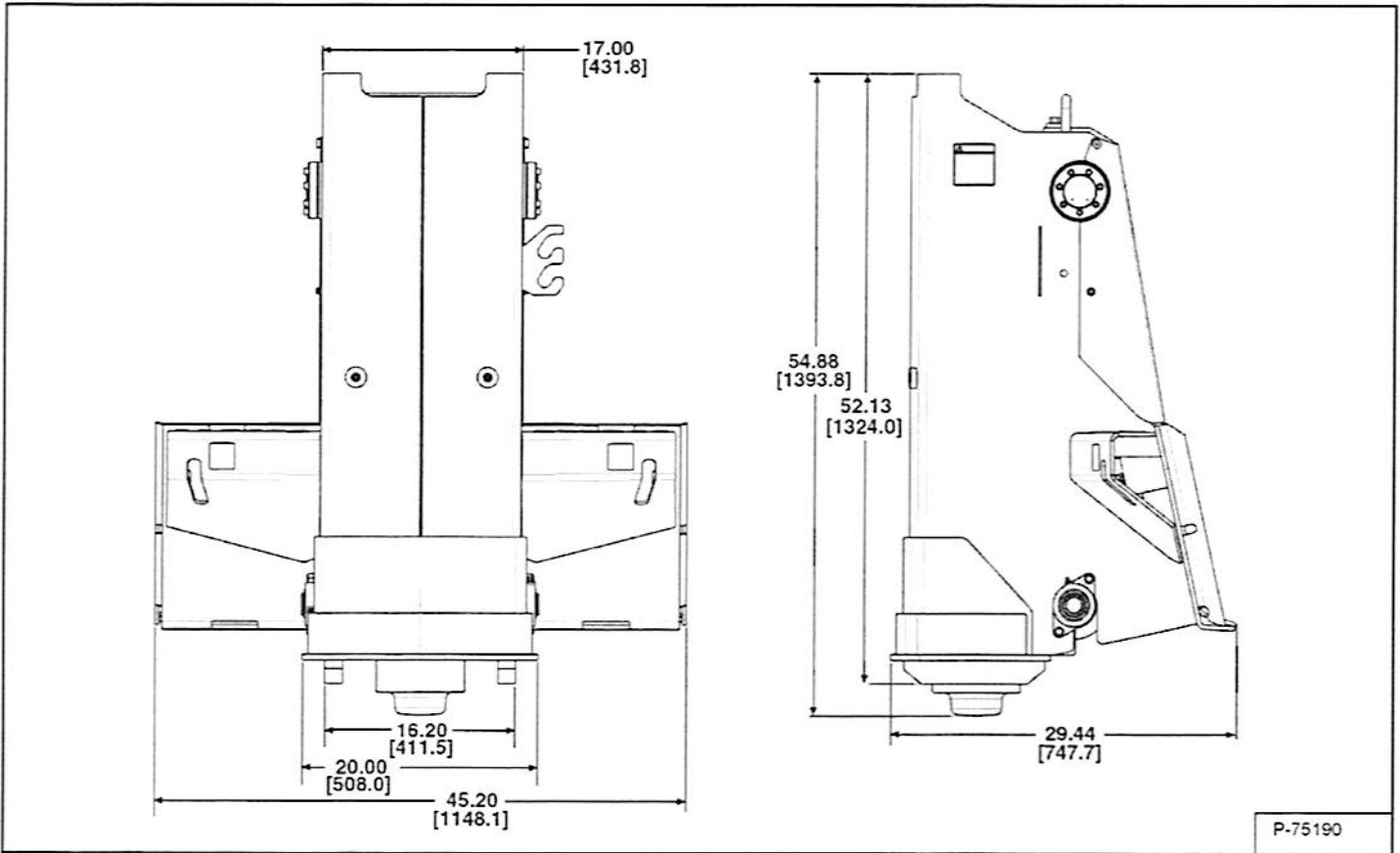

P-75190

DESCRIPTION	DROP HAMMER
Chain	#80 HSOC
Operation Weight	1925 lb. (873 kg)
Tool Point	65 lb. (29.5 kg)
Hammer Weight	1140 lb. (518 kg)
Minimum Flow	13 GPM (49.2 L/min.)
Maximum Flow	22 GPM (83.3 L/min.)
Stroke Rate	20 STROKES / MINUTE

HYDRAULIC SCHEMATIC

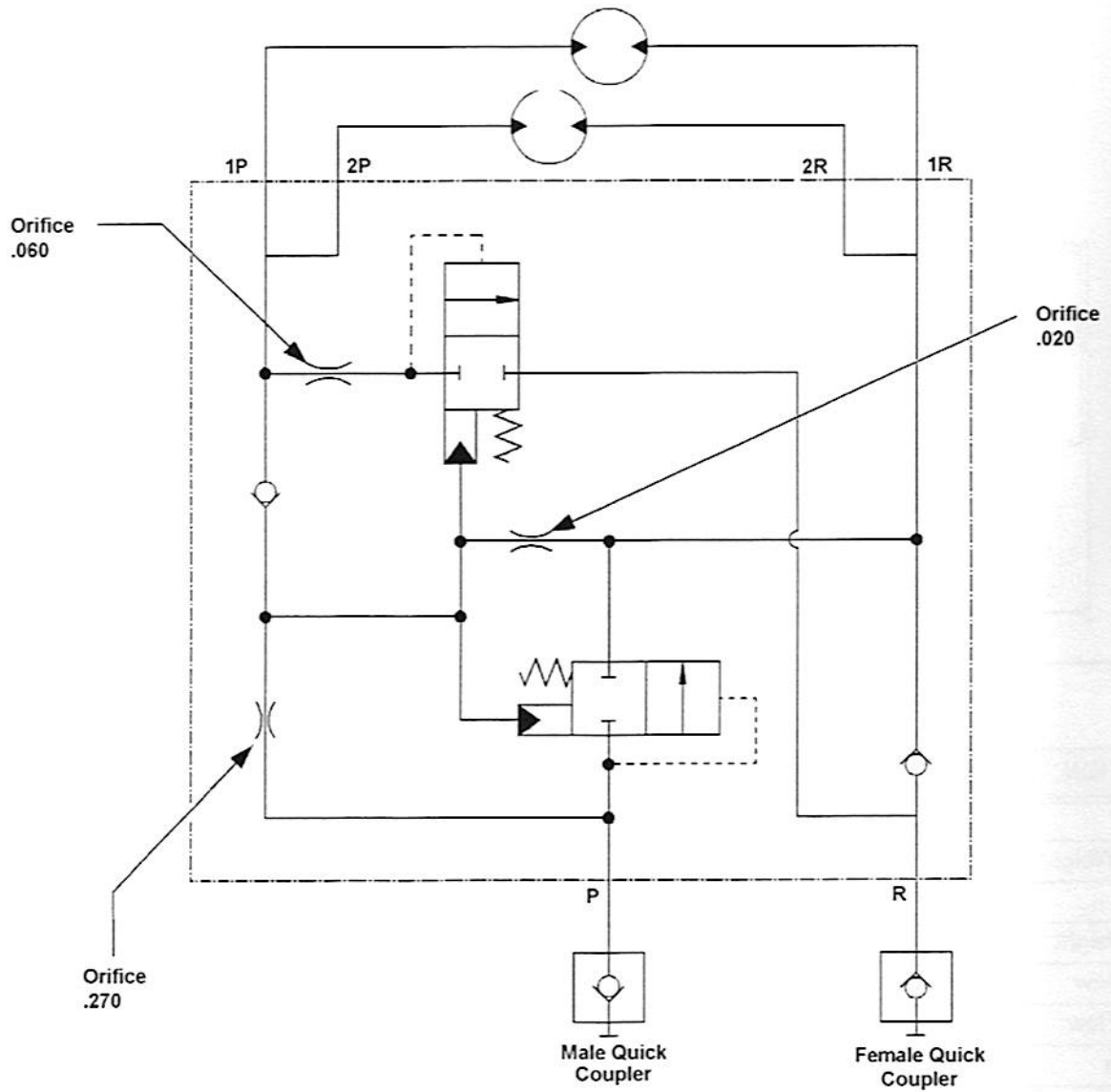

P-70875

WARRANTY

WARRANTYWARRANTY-3

WARRANTY

WARRANTY

Bobcat Attachments

Bobcat Company warrants to its authorized dealers and authorized dealers of Bobcat Equipment Ltd., who in turn warrant to the original owner, that each new Bobcat attachment will be free from proven defects in material and workmanship for twelve (12) months after delivery by the authorized Bobcat dealer to the original buyer.

During the warranty period, the authorized Bobcat dealer shall repair or replace, at Bobcat Company's option, without charge for parts and labor, any part of the Bobcat product which fails because of defects in material or workmanship. The owner shall provide the authorized Bobcat dealer with prompt written notice of the defect and allow reasonable time for replacement or repair. Bobcat Company may, at its option, require failed parts to be returned to the factory. Travel time of mechanics and transportation of the Bobcat product to the authorized Bobcat dealer for warranty work are the responsibility of the owner. The remedies provided in this warranty are exclusive.

This warranty does not cover replacement of scheduled service items and high wear items. The owner shall rely solely on the warranty, if any, of the respective manufacturers thereof. This warranty does not cover damages resulting from abuse, accidents, alterations, use of the Bobcat product as an attachment on any equipment not approved by Bobcat Company, air flow obstructions, or failure to maintain or use the Bobcat product according to the instructions applicable to it.

THIS WARRANTY IS EXCLUSIVE AND IN LIEU OF ALL OTHER WARRANTIES AND CONDITIONS, EXCEPT THE WARRANTY OF TITLE. BOBCAT COMPANY DISCLAIMS ALL OTHER WARRANTIES AND CONDITIONS, EXPRESS OR IMPLIED, INCLUDING ANY IMPLIED WARRANTIES OR CONDITIONS OF MERCHANTABILITY OR FITNESS FOR A PARTICULAR PURPOSE. IN NO EVENT SHALL BOBCAT COMPANY OR THE AUTHORIZED BOBCAT DEALER BE LIABLE FOR ANY SPECIAL, INCIDENTAL, INDIRECT OR CONSEQUENTIAL DAMAGES, WHATSOEVER, INCLUDING, BUT NOT LIMITED TO, LOSS OR INTERRUPTION OF BUSINESS, LOST PROFITS, OR LOSS OF MACHINE USE, WHETHER BASED ON CONTRACT, WARRANTY, TORT, NEGLIGENCE, STRICT LIABILITY, STATUTE OR OTHERWISE, EVEN IF BOBCAT COMPANY OR THE AUTHORIZED BOBCAT DEALER HAS BEEN ADVISED OF THE POSSIBILITY OF SUCH DAMAGES. THE TOTAL LIABILITY OF BOBCAT COMPANY AND THE AUTHORIZED BOBCAT DEALERS WITH RESPECT TO THE PRODUCT AND SERVICES FURNISHED HEREUNDER SHALL NOT EXCEED THE PURCHASE PRICE OF THE PRODUCT UPON WHICH SUCH LIABILITY IS BASED.



Bobcat®

ALPHABETICAL INDEX

BOBCAT COMPANY IS ISO 9001:2000 CERTIFIED	V
DAILY INSPECTION	OI-3
DELIVERY REPORT	VI
FEATURES AND ACCESSORIES	VIII
HYDRAULIC SCHEMATIC	SPEC-4
LIFTING THE DROP HAMMER	OI-17
LUBRICATION	PM-5
OPERATING PROCEDURE WITH LOADERS	OI-6
PUBLICATIONS AND TRAINING RESOURCES	XIV
SAFETY INSTRUCTIONS	XI
SERIAL NUMBER LOCATION	VI
SERVICE SCHEDULE	PM-4
SPECIFICATIONS	SPEC-3
TRANSPORT LOCK	OI-16
TRANSPORTING THE DROP HAMMER AND MACHINE ON A TRAILER	OI-18
TRANSPORTING THE DROP HAMMER ON A TRAILER	OI-17
TROUBLESHOOTING	PM-3
WARRANTY	WARNING-3

**ALPHABETICAL
INDEX**