

EN

# S205



# Bobcat®

# Operation & Maintenance Manual

S/N 530611001 & Above

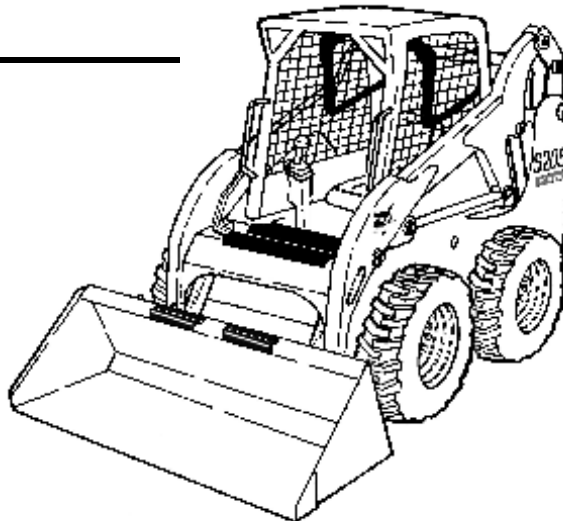

EQUIPPED WITH  
BOBCAT INTERLOCK  
CONTROL SYSTEM (BICS)

6904136-EN (09-06)

An  Ingersoll Rand business

Printed in Europe

© Bobcat Europe 2006

# OPERATOR SAFETY WARNINGS



## WARNING

Operator must have instructions before running the machine. Untrained operators can cause injury or death.

W-2001-1285



**Safety Alert Symbol:** This symbol with a warning statement, means: "Warning, be alert! Your safety is involved!" Carefully read the message that follows.

CORRECT



B-10731A

⚠ Never use the loader without instructions. See machine signs (decals), Operation & Maintenance Manual, and Operator's Handbook.

CORRECT

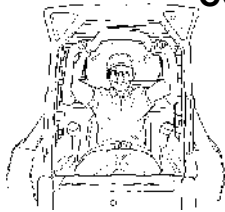

B-16245

⚠ Always use the seat bar and fasten seat belt snugly.  
⚠ Always keep feet on the foot pedals or foot rest when operating loader.

WRONG

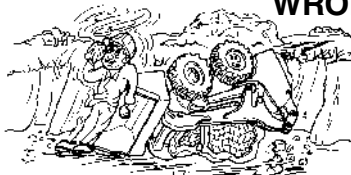

B-15528

⚠ Never use loader without operator cab with ROPS and FOPS approval. Fasten your seat belt.

WRONG

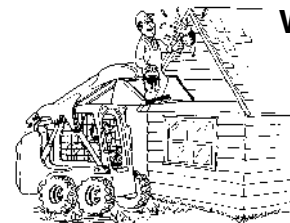

B-15531

⚠ Never use loader as man lift or elevating device for personnel.

WRONG

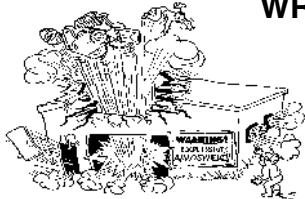

B-15735

⚠ Do not use loader in atmosphere with explosive dust, explosive gas, or where exhaust can contact flammable material.

WRONG

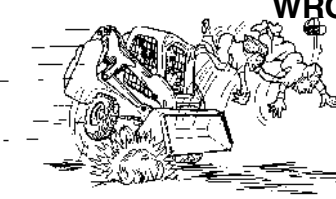

B-15529

⚠ Never carry riders.  
⚠ Keep bystanders away from work area.

WRONG

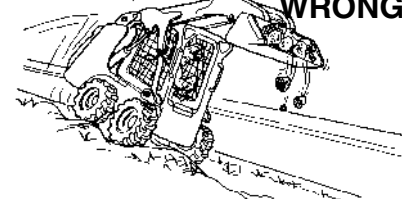

B-15532

⚠ Always carry bucket or attachments as low as possible.  
⚠ Do not travel or turn with lift arms up.  
⚠ Load, unload, and turn on flat level ground.

WRONG

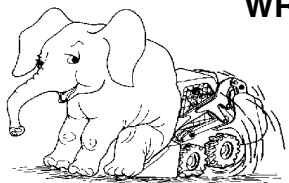

B-15527

⚠ Never exceed Rated Operating Capacity.

WRONG

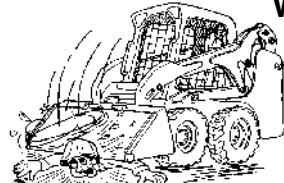

B-15530

⚠ Never leave loader with engine running or with lift arms up.  
⚠ To park, engage parking brake and put attachment flat on the ground.

WRONG

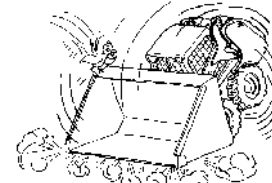

B-15533

⚠ Never modify equipment.  
⚠ Use only attachments approved by Bobcat Company for this model loader.

## SAFETY EQUIPMENT

The Bobcat Loader must be equipped with safety items necessary for each job. Ask your dealer about attachments and accessories.

1. SEAT BELT: Check belt fasteners and check for damaged webbing or buckle.
2. SEAT BAR: When up, it must lock the loader controls.
3. OPERATOR CAB (ROPS and FOPS): It must be on the loader with all fasteners tight.
4. HANDBOOK: Must be in the cab.
5. SAFETY SIGNS (DECALS): Replace if damaged.
6. SAFETY TREADS: Replace if damaged.
7. GRAB HANDLES: Replace if damaged.
8. LIFT ARM SUPPORT DEVICE: Replace if damaged.
9. PARKING BRAKE
10. BOBCAT INTERLOCK CONTROL SYSTEM (BICS)

OSW08-0805

# CONTENTS

FOREWORD .....III  
SAFETY ..... XI  
OPERATING INSTRUCTIONS ..... 1  
PREVENTIVE MAINTENANCE .....59  
SYSTEM SETUP & ANALYSIS .....103  
SPECIFICATIONS .....117

## REFERENCE INFORMATION

Write the correct information for YOUR Bobcat Loader in the spaces below. Always use these numbers when referring to your Bobcat Loader.

Loader Serial Number \_\_\_\_\_  
Engine Serial Number \_\_\_\_\_  
\_\_\_\_\_  
\_\_\_\_\_

NOTES:

\_\_\_\_\_  
\_\_\_\_\_  
\_\_\_\_\_  
\_\_\_\_\_

YOUR BOBCAT DEALER:

ADDRESS:

PHONE:

\_\_\_\_\_



Bobcat Europe  
Drève Richelle 167  
B-1410 WATERLOO  
Belgium

**FOREWORD**

**SAFETY**

**OPERATING  
INSTRUCTIONS**

**PREVENTIVE  
MAINTENANCE**

**SYSTEM SETUP  
& ANALYSIS**

**SPECIFICATIONS**



**Bobcat®**

## FOREWORD

## FOREWORD

This Operation & Maintenance Manual was written to give the owner / operator instructions on the safe operation and maintenance of the Bobcat Loader. READ AND UNDERSTAND THIS OPERATION & MAINTENANCE MANUAL BEFORE OPERATING YOUR MACHINE. If you have any questions, see your Bobcat dealer.

BOBCAT COMPANY IS ISO 9001:2000 CERTIFIED .....	V
DELIVERY REPORT .....	VI
FEATURES, ACCESSORIES AND ATTACHMENTS .....	VIII
Attachments .....	IX
Buckets Available .....	IX
High Flow Attachments .....	IX
Options and Accessories .....	VIII
Special Applications Kit.....	X
Special Applications Kit Inspection And Maintenance .....	X
Standard Items.....	VIII
LOADER IDENTIFICATION.....	VII
MOTOR OIL.....	V
REGULAR MAINTENANCE ITEMS.....	V
SERIAL NUMBER LOCATIONS.....	VI
Engine Serial Number.....	VI
Loader Serial Number.....	VI



**Bobcat®**

**BOBCAT COMPANY IS ISO 9001:2000 CERTIFIED**













**ISO 9001:2000** is an international standard that controls the processes and procedures which we use to design, develop, manufacture and distribute Bobcat products.

British Standards Institute (**BSI**) is the Certified Registrar Bobcat Company chose to assess the Company's compliance with the ISO 9001:2000 standard. The BSI registration certifies that the two Bobcat manufacturing plants and the Bobcat corporate offices (Gwinner, Bismarck & West Fargo) in North Dakota are in compliance with ISO 9001:2000. Only certified assessors, like BSI, can grant registrations.

ISO 9001:2000 means that as a company we say what we do and do what we say. In other words, we have established procedures and policies, and we provide evidence that the procedures and policies are followed.

**REGULAR MAINTENANCE ITEMS**

	<b>ENGINE OIL FILTER (6 Pack)</b> 6675517		<b>HYDROSTATIC FILTER, In-Line</b> 6661022
	<b>FUEL FILTER</b> 6667352		<b>BATTERY</b> 6674687
	<b>AIR FILTER, Outer</b> 6598492		<b>FLUID, Hydraulic / Hydrostatic</b> 6903117 - (9,5 L) 6903118 - (19 L) 6903119 - (208 L)
	<b>AIR FILTER, Inner</b> 6598362		<b>COOLANT PRESSURE CAP</b> 6672491
	<b>HYDROSTATIC FILTER</b> 6661248 (152 mm) - for Std. Flow 6668819 (241 mm) - for High Flow		<b>PROPYLENE GLYCOL ANTI-FREEZE,</b> 6724354 - Concentrate 6724094 - Premixed [-37°C (-34°F)]

**MOTOR OIL**

6903105 - SAE 15W40 CE/SG (12 L)	6903106 - SAE 15W40 CE/ SG (3,8 L)
6903107 - SAE 10W30 CE/SG (12 L)	6903108 - SAE 10W30 CE/SG (3,8 L)
6903109 - SAE 30W CE/SG (12 L)	6903110 - SAE 30W CE/SG (3,8 L)
6903113 - SAE 15W40 CE/SG (9,5 L)	6903111 - SAE 30W CE/SG (9,5 L)
6903112 - SAE 10W30 CE/SG (9,5 L)	

## SERIAL NUMBER LOCATIONS

Always use the serial number of the loader when requesting service information or when ordering parts. Early or later models (identification made by serial number) may use different parts, or it may be necessary to use a different procedure in doing a specific service operation.

Figure 1



### Loader Serial Number

The loader serial number plate is located on the outside of the loader frame [Figure 1].

Explanation of loader Serial Number:

XXXX XXXXX

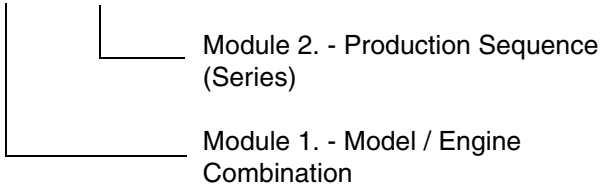

1. The four digit Model / Engine Combination Module number identifies the model number and engine combination.
2. The five digit Production Sequence Number identifies the order which the loader is produced.

## Engine Serial Number

Figure 2

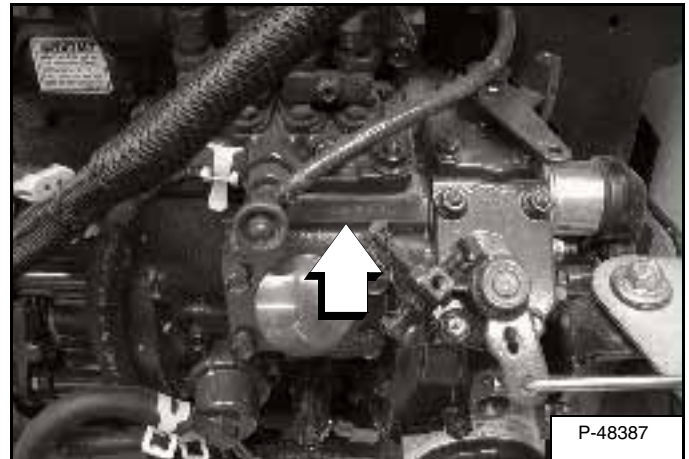

The engine serial number is located on the side of the engine [Figure 2] above the oil filter.

## DELIVERY REPORT

Figure 3

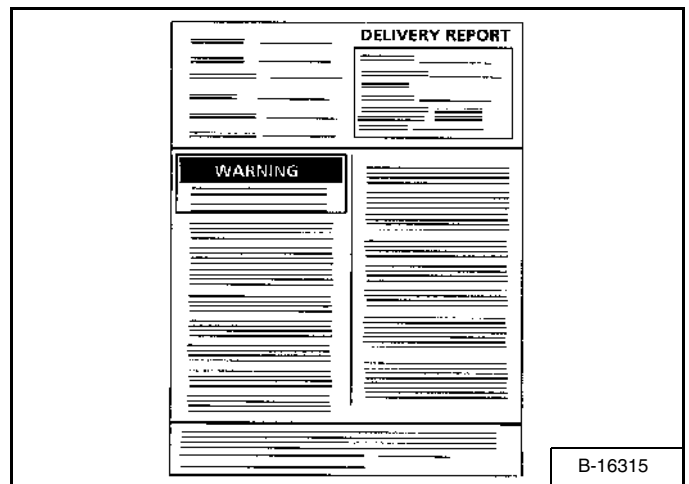

The delivery report must be filled out by the dealer and signed by the owner or operator when the Bobcat Loader is delivered. An explanation of the form must be given to the owner. Make sure it is filled out completely [Figure 3].



**LOADER IDENTIFICATION**

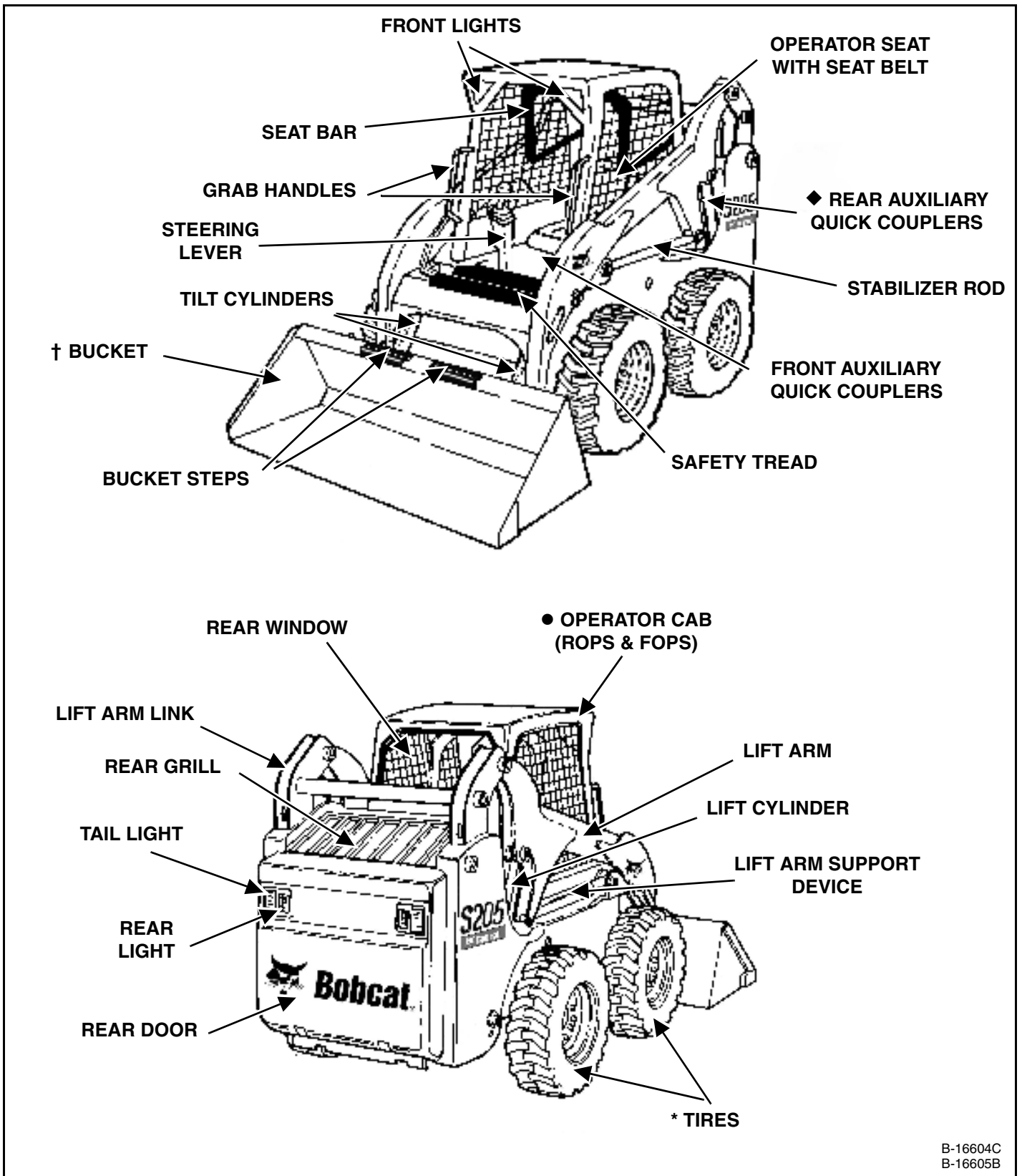

B-16604C  
B-16605B

- ◆ Optional or Field Accessory (Not Standard Equipment)
- \* TIRES - Tires shown may not be standard. The machine is factory equipped with standard tires. Other tires are available.
- † BUCKET - Several different buckets and other attachments are available for this machine.
- ROPS, FOPS - Roll Over Protective Structure, per SAE and ISO 3471, and Falling Object Protective Structure per ISO 3449, Level I. Level II is available.

## FEATURES, ACCESSORIES AND ATTACHMENTS

### Standard Items

Model S205 Bobcat Loaders are equipped with the following standard items:

- 7-pin attachment control kit
- Attachment electrical control kit
- Automatically activated glow-plugs
- Auxiliary hydraulics: variable flow / maximum flow
- Bobcat Interlock Control System (BICS)
- Bob-Tach™ frame
- CE certification
- Deluxe operator cab\*  
Includes interior cab foam, side, top and rear windows, Deluxe wire harness, dome light, and electrical power port
- Electrically activated proportional front auxiliary hydraulics
- Engine / hydraulics system shutdown
- High-back cushion suspension seat
- Hydraulic bucket positioning (including ON / OFF switch)
- Instrumentation
- Lift arm support
- Operating lights, front and rear
- Parking brake
- Seat bar
- Seat belt
- Spark arrestor muffler
- Tyres - 31 x 12-16.5, 10-ply, Bobcat Heavy Duty Wide Flotation
- Warranty: 12 months or 2000 hours

\* **Roll Over Protective Structure (ROPS)** - meets requirements of SAE-J1040 and ISO 3471; **Falling Object Protective Structure (FOPS)** - meets requirements of SAE-J1043 and ISO 3449, Level I

### Options and Accessories

Below is a list of some equipment available from your Bobcat Loader dealer as Dealer and / or Factory Installed Accessories and Factory Installed Options. See your Bobcat dealer for other available options, accessories and attachments.

- Dealer Installed Accessories
  - Air conditioning kit
  - Back up alarm kit
  - Cab enclosure kit
  - Counterweight kit
  - Deluxe instrument panel
  - Door sensor kit
  - FOPS kit\*\*
  - Four-point lift kit
  - Fresh air heater kit
  - Front door kit
  - Fuel cap locking kit
  - Operator cab, CE, enclosure kit
  - Plumbing kit for fresh air heater
  - Power Bob-Tach™ kit
  - Rear auxiliary hydraulic kit
  - Replacement Bob-Tach™
  - Replacement operator cab structure
  - Single-point lift kit
  - Special applications kit
- Factory Options
  - Advanced Control System (ACS)
  - Advanced Hand Controls (AHC)
  - Air conditioning
  - Cab enclosure with heat
  - Deluxe instrument panel
  - High-flow auxiliary hydraulics
  - High-flow hydraulics
  - Power Bob-Tach™
  - Selectable Joystick Control (SJC)

\*\* **Falling Objects Protective Structure (FOPS)** - meets requirements of SAE-J1043 and ISO 3449, Level II

*Specifications subject to change without notice.*

## FEATURES, ACCESSORIES AND ATTACHMENTS (CONT'D)

These and other attachments are approved for use on this model loader. Do not use unapproved attachments. Attachments not manufactured by Bobcat may not be approved.

The versatile Bobcat Loader quickly turns into a multi-job machine with a tight-fit attachment hook-up . . . from bucket to grapple to pallet fork to backhoe and a variety of other attachments.

See your Bobcat dealer for more details on these and other attachments and field accessories.

Increase the versatility of your Bobcat Loader with a variety of bucket styles and sizes.

### Attachments

For specific model availability, see Bobcat Product Price List.

- Angle blade
- Angle broom\*†
- Auger
- Backhoe
- Box blade
- Brushcat rotary cutter
- Buckets
- Combination bucket
- Concrete pump\*
- Cutter crusher\*
- Digger
- Dozer blade\*
- Dumping hopper
- Ejector bucket
- Farm grapple
- Grader\*
- Hydraulic breaker\*\*
- Industrial grapple
- Landplane
- Landscape rake
- Mixing bucket\*
- Pallet fork - hydraulic
- Pallet fork - standard
- Planer\*
- Rear stabiliser
- Scarifier
- Snow blower\*
- Sod layer\*
- Soil conditioner\*
- Spreader
- Stump grinder\*
- Super scraper
- Sweeper
- Three-point hitch
- Tiller
- Tilt-Tatch™
- Tracks, steel
- Tree transplanter\*

### Buckets Available

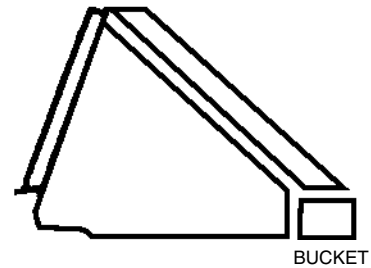

Many bucket styles, widths and different capacities are available for a variety of different applications. They include Construction & Industry, Low profile, Fertilizer and Snow, to name a few. See your Bobcat dealer for the correct bucket for your Bobcat Loader and application.

- Trench compactor
- Trencher
- Utility forks
- Vibratory roller
- Water kit
- Whisker broom

\* **Attachment control kit required.**

\*\* **When operating the loader with this attachment, a Special Applications Kit, which includes a 12 mm Lexan front door with 6 mm top and rear windows, must be used.**

† **Optional water kit.**

See your Bobcat dealer for these and other attachments available for your loader.

### High Flow Attachments

**The following attachments are approved for use on High Flow machines. See your Bobcat dealer for an updated list of approved attachments.**

- Chipper
- Planer
- Rotary Cutter (Brushcat)
- Snow Blower
- Tiller
- Trencher
- Wheel Saw

**NOTE: Not all Bobcat High Flow Attachment models are approved for use with 152 L/min flow. Damage to attachment or machine can result when using unapproved attachments.**

## FEATURES, ACCESSORIES AND ATTACHMENTS (CONT'D)

### Special Applications Kit

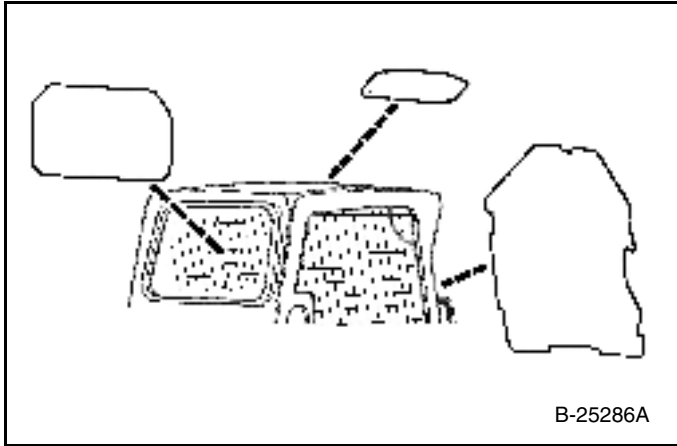

Available for special applications to restrict material from entering cab openings. Kit includes 12 mm Lexan™ front door, top and rear windows.

See your Bobcat dealer for availability.

### Special Applications Kit Inspection And Maintenance

- Inspect for cracks or damage. Replace if required.
- Pre-rinse with water to remove gritty materials.
- Wash with a mild household detergent and warm water.
- Use a sponge or soft cloth. Rinse well with water and dry with a clean soft cloth or rubber squeegee.
- Do not use abrasive or highly alkaline cleaners.
- Do not clean with metal blades or scrapers.

# SAFETY

MACHINE SIGNS (DECALS) .....	XVI
SAFETY INSTRUCTIONS.....	XIII
Before Operation.....	XIII
Fire Prevention.....	XV
Safe Operation Is The Operator's Responsibility .....	XIV
Safe Operation Needs A Qualified Operator.....	XIV

**SAFETY**



**Bobcat®**

## SAFETY INSTRUCTIONS

### Before Operation

Carefully follow the operating and maintenance instructions in this manual.

The Bobcat Loader is highly maneuverable and compact. It is rugged and useful under a wide variety of conditions. This presents an operator with hazards associated with off highway, rough terrain applications, common with Bobcat Loader usage.

The Bobcat Loader has an internal combustion engine with resultant heat and exhaust. All exhaust gasses can kill or cause illness so use the Loader with adequate ventilation.

The dealer explains the capabilities and restrictions of the Bobcat Loader and attachment for each application. The dealer demonstrates the safe operation according to Bobcat instructional materials, which are also available to operators. The dealer can also identify unsafe modifications or use of unapproved attachments. The attachments and buckets are designed for a Rated Operating Capacity (some have restricted lift heights). They are designed for secure fastening to the Bobcat Loader. The user must check with the dealer, or Bobcat literature, to determine safe loads of materials of specified densities for the machine - attachment combination.

The following publications and training materials provide information on the safe use and maintenance of the Bobcat machine and attachments:

- The Delivery Report is used to assure that complete instructions have been given to the new owner and that the machine and attachment is in safe operating condition.
- The Operation & Maintenance Manual delivered with the machine or attachment gives operating information as well as routine maintenance and service procedures. It is a part of the machine and can be stored in a container provided on the machine. Replacement Operation & Maintenance Manuals can be ordered from your Bobcat dealer.
- Machine signs (decals) instruct on the safe operation and care of your Bobcat machine or attachment. The signs and their locations are shown in the Operation & Maintenance Manual. Replacement signs are available from your Bobcat dealer.

- An Operator's Handbook is fastened to the operator cab of the Loader. It's brief instructions are convenient to the operator. The Handbook is available from your dealer in an English edition or one of many other languages. See your Bobcat dealer for more information on translated versions.

SI SSL-0206

## SAFETY INSTRUCTIONS (CONT'D)

### Safe Operation Is The Operator's Responsibility

**Safety Alert Symbol**

This symbol with a warning statement means:  
"Warning, be alert! Your safety is involved!"  
Carefully read the message that follows.



**Operator must have instructions before running the machine. Untrained operators can cause injury or death.**

W-2001-1285



**This notice identifies procedures which must be followed to avoid damage to the machine.**

I-2019-0284



**Warnings on the machine and in the manuals are for your safety. Failure to obey warnings can cause injury or death.**

W-2044-1285

The Bobcat Loader and attachment must be in good operating condition before use.

Check all of the items on the Bobcat Service Schedule Decal under the 8-10 hour column or as shown in the Operation & Maintenance Manual.

### Safe Operation Needs A Qualified Operator

For an operator to be qualified, he or she must not use drugs or alcoholic drinks which impair alertness or coordination while working. An operator who is taking prescription drugs must get medical advice to determine if he or she can safely operate a machine.

### ***A Qualified Operator Must Do The Following:***

#### **Understand the Written Instructions, Rules and Regulations**

- The written instructions from Bobcat Company include the Delivery Report, Operation & Maintenance Manual, Operator's Handbook and machine signs (decals).
- Check the rules and regulations at your location. The rules may include an employer's work safety requirements. Regulations may apply to local driving requirements or use of a Slow Moving Vehicle emblem. Regulations may identify a hazard such as a utility line.

#### **Have Training with Actual Operation**

- Operator training must consist of a demonstration and verbal instruction. This training is given by your Bobcat dealer before the product is delivered.
- The new operator must start in an area without bystanders and use all the controls until he or she can operate the machine and attachment safely under all conditions of the work area. Always fasten seat belt before operating.

#### **Know the Work Conditions**

- Know the weight of the materials being handled. Avoid exceeding the Rated Operating Capacity of the machine. Material which is very dense will be heavier than the same volume of less dense material. Reduce the size of the load if handling dense material.
- The operator must know any prohibited uses or work areas, for example, he or she needs to know about excessive slopes.
- Know the location of any underground lines.
- Wear tight fitting clothing. Always wear safety glasses when doing maintenance or service. Safety glasses, hearing protection or Special Applications Kits are required for some work. See your Bobcat dealer about Bobcat Safety Equipment for your model.

SI SSL-0206



## SAFETY INSTRUCTIONS (CONT'D)

### Fire Prevention

The machines and some attachments have components that are at high temperatures under normal operating conditions. The primary source of high temperatures is the engine and exhaust system. The electrical system, if damaged or incorrectly maintained, can be a source of arcs or sparks.

Flammable debris (leaves, straw, etc.) must be removed regularly. If flammable debris is allowed to accumulate, it can cause a fire hazard. Clean often to avoid this accumulation. Flammable debris in the engine compartment is a potential fire hazard.

The spark arrestor exhaust system is designed to control the emission of hot particles from the engine and exhaust system, but the muffler and the exhaust gases are still hot.

- Do not use the machine where exhaust, arcs, sparks or hot components can contact flammable material, explosive dust or gases.
- The operator cab, engine compartment and engine cooling system must be inspected every day and cleaned if necessary to prevent fire hazards and overheating.
- Check all electrical wiring and connections for damage. Keep the battery terminals clean and tight. Repair or replace any damaged part.
- Check fuel and hydraulic tubes, hoses and fittings for damage and leakage. Never use open flame or bare skin to check for leaks. Tighten or replace any parts that show leakage. Always clean fluid spills. Do not use gasoline or diesel fuel for cleaning parts. Use commercial nonflammable solvents.
- Do not use ether or starting fluids on any engine that has glow plugs. These starting aids can cause explosion and injure you or bystanders.
- Always clean the machine, disconnect the battery, and disconnect the wiring from the Bobcat controllers before welding. Cover rubber hoses, battery and all other flammable parts. Keep a fire extinguisher near the machine when welding. Have good ventilation when grinding or welding painted parts. Wear dust mask when grinding painted parts. Toxic dust or gas can be produced.
- Stop the engine and let it cool before adding fuel. No smoking!
- Use the procedure in the Operation & Maintenance Manual for connecting the battery and for jump starting.

- Use the procedure in the Operation & Maintenance Manual for cleaning the spark arrestor muffler (if equipped).

Figure 4

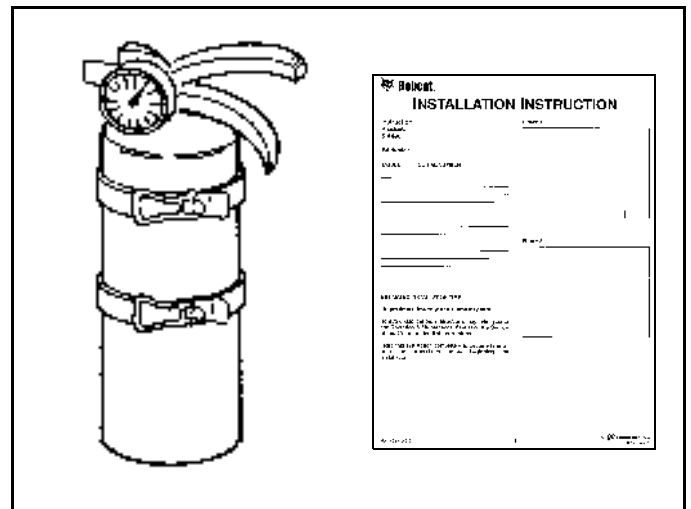

- Know where fire extinguishers and first aid kits are located and how to use them. Fire extinguishers are available from your Bobcat dealer [Figure 4].

SI SSL-0206







**Bobcat®**

# OPERATING INSTRUCTIONS

ATTACHMENTS .....	38
Choosing The Correct Bucket.....	38
Installing And Removing The Attachment (Hand Lever Bob-Tach).....	39
Installing And Removing The Attachment (Power Bob-Tach Option)...	41
Pallet Forks .....	38
BOBCAT INTERLOCK CONTROL SYSTEM (BICS) .....	11
Operation .....	11
DAILY INSPECTION.....	25
Daily Inspection and Maintenance .....	26
DRIVING AND STEERING THE LOADER .....	14
Available Controls Configurations .....	14
Operation (SJC) in 'H' Control Pattern.....	15
Operation (SJC) in 'ISO' Control Pattern .....	16
Operation (Standard and ACS) .....	14
ENGINE SPEED CONTROL.....	13
Operation .....	13
HYDRAULIC CONTROLS.....	18
Advanced Control System (ACS) In HAND Control Mode .....	19
Attachment Control Device (ACD) (If Equipped).....	24
Auxiliary Hydraulics Operation (MAXIMUM FLOW ONLY) .....	21
Auxiliary Hydraulics Operation (VARIABLE FLOW).....	21
Bucket Position Valve Operation (If Equipped) .....	20
Description .....	18
FRONT Auxiliary Hydraulics Operation (CONTINUOUS FLOW).....	22
FRONT Auxiliary Hydraulics Operation (MAXIMUM FLOW) .....	21
FRONT Auxiliary Hydraulics Operation (VARIABLE FLOW).....	21
High-Flow Hydraulics Operation (If Equipped).....	23
Quick Couplers .....	22
REAR Auxiliary Hydraulics Operation (If Equipped) .....	22
Relieve Hydraulic Pressure (Loader and Attachment) .....	23
Secondary Front Auxiliary Hydraulics (If Equipped) .....	24
Selectable Joystick Control (SJC) In 'H' Control Pattern .....	19
Selectable Joystick Control (SJC) In 'ISO' Control Pattern .....	20
Standard Controls (Also ACS In FOOT Pedal Mode) .....	18
INSTRUMENT PANEL IDENTIFICATION .....	5
Cab Light.....	8
Left Panel.....	5
Option And Field Accessory Panels.....	9
Right Panel (Key Switch) .....	6
Right Panel (Keyless).....	7
LIFT ARM BY-PASS CONTROL.....	12

**OPERATING  
INSTRUCTIONS**

## OPERATING INSTRUCTIONS (CONT'D)

LIFTING THE LOADER .....	56
Four Point Lift .....	56
Single Point Lift.....	56
MONITORING THE DISPLAY PANELS .....	34
Left Panel.....	34
Right Panel (Key Switch) .....	34
Right Panel (Keyless) .....	35
Warning And Shutdown.....	35
OPERATING PROCEDURE .....	44
Digging And Filling A Hole (ACS - Handles, SJC - 'H' Pattern) .....	51
Digging And Filling A Hole (Foot Pedals).....	48
Digging And Filling A Hole (SJC - 'ISO' Pattern) .....	54
Filling And Emptying The Bucket (ACS - Handles, SJC - 'H' Pattern)....	49
Filling And Emptying The Bucket (Foot Pedals) .....	46
Filling And Emptying The Bucket (SJC - 'ISO' Pattern) .....	52
Inspect The Work Area.....	44
Leveling The Ground Using Float (ACS - Handles, SJC - 'H' Pattern) ...	50
Leveling The Ground Using Float (Foot Pedals).....	47
Leveling The Ground Using Float (SJC - 'ISO' Pattern) .....	53
Operating With A Full Bucket.....	44
Operating With An Empty Bucket .....	45
PARKING BRAKE .....	13
PRE-STARTING PROCEDURE.....	27
Entering The Loader.....	27
Seat Adjustment .....	27
Seat Bar.....	28
Seat Belt Adjustment .....	28
SEAT BAR RESTRAINT SYSTEM .....	10
Operation.....	10
SPEED MANAGEMENT (SJC OPTION) .....	17
Operation.....	17
STARTING THE ENGINE .....	29
Cold Temperature Starting.....	32
Key Switch .....	29
Keyless .....	31
Warming The Hydraulic / Hydrostatic System .....	33
STOPPING THE ENGINE AND LEAVING THE LOADER.....	36
Emergency Exit .....	37
Procedure .....	36
STOPPING THE LOADER.....	16
Using The Control Levers Or Joysticks.....	16

## OPERATING INSTRUCTIONS (CONT'D)

TOWING THE LOADER .....	55
Procedure .....	55
TRACTION LOCK OVERRIDE.....	12
Operation .....	12
TRANSPORTING THE LOADER ON A TRAILER .....	57
Fastening .....	57
Loading And Unloading.....	57



**Bobcat®**



## INSTRUMENT PANEL IDENTIFICATION

### Left Panel

Figure 5

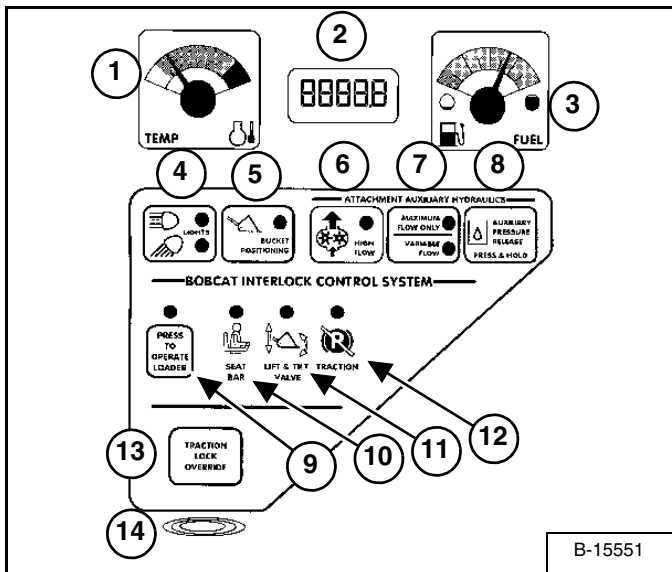

The left instrument panel is the same for both the Key Switch and Keyless Instrument Panels [Figure 5].

The table below shows the DESCRIPTION and FUNCTION / OPERATION for each of the components of the left panel.

REF. NO	DESCRIPTION	FUNCTION / OPERATION
1	TEMPERATURE GAUGE	Shows the engine coolant temperature.
2	HOURMETER / CODE DISPLAY / GLOW PLUG COUNTDOWN	HOURMETER - Records operating hours of loader. CODE DISPLAY - Display numeric SERVICE CODES* relating to the loader monitoring system. COUNTDOWN - Preheat time remaining
3	FUEL GAUGE	Shows the amount of fuel in the tank.
4	LIGHTS / HOLD FOR CODES	LIGHTS - Press once for FRONT LIGHTS. Press a second time for FRONT AND REAR lights. Press a third time to turn all lights off. HOLD FOR CODES - Press and hold two seconds for display of SERVICE CODES (2). (CODES* show only when there is an error found by loader monitoring system.)
5	BUCKET POSITIONING (Option)	Press to engage the BUCKET POSITIONING function. Press again to disengage. Press and hold 2 seconds to view SHTDN (SHUTDOWN) feature & Operational Code Number in HOURMETER / CODE DISPLAY.
<b>ATTACHMENT AUXILIARY HYDRAULICS</b>		
6	HIGH FLOW (Option)	Press to engage the HIGH FLOW auxiliary hydraulics. Press again to disengage.
7	MAXIMUM FLOW / VARIABLE FLOW	Press once to engage the VARIABLE FLOW auxiliary hydraulics. Press a second time to engage MAXIMUM FLOW. Press a third time to disengage all auxiliary hydraulics. [VARIABLE FLOW allows for slow-to-fast movement of auxiliary functions. (The farther you move the switch, the faster the movement of auxiliary functions.) MAXIMUM FLOW allows for only fast movement.]
8	AUXILIARY PRESSURE RELEASE	Rear Auxiliary Only - With key ON or engine running, press and hold button for 5 seconds. (See Relieve Hydraulic Pressure (Loader and Attachment) on Page 23 for front auxiliary pressure release.)
<b>BOBCAT INTERLOCK CONTROL SYSTEM (BICS)</b>		
(See SYSTEM SETUP & ANALYSIS on Page 103 for more information.)		
9	PRESS TO OPERATE LOADER	Press to activate BICS System when the Seat Bar is down and operator is seated in operating position.
10	SEAT BAR	The light comes ON when the seat bar is down.
11	LIFT & TILT VALVE	The light comes ON when the seat bar is down and the PRESS TO OPERATE Button is pressed. The lift and tilt functions <u>can</u> be operated when the light is ON.
12	TRACTION	The light comes ON when the seat bar is down, engine is running, and parking brake is released. The loader <u>can</u> be moved forward or backward when the light is ON.
13	TRACTION LOCK OVERRIDE	(Function Only When Seat Bar Is Raised And The Engine Is Running) Press to unlock the brakes. Allows you to use the steering levers to move the loader forward or backward when using the backhoe attachment or for loader service. (See TRACTION LOCK OVERRIDE on Page 12.) Press a second time to lock the brakes.
14	ALARM	The ALARM beeps when there is an Error, WARNING or SHUTDOWN condition.

\* See SYSTEM SETUP & ANALYSIS on Page 103 for further description of SERVICE CODES.

## INSTRUMENT PANEL IDENTIFICATION (CONT'D)

### Right Panel (Key Switch)

Figure 6

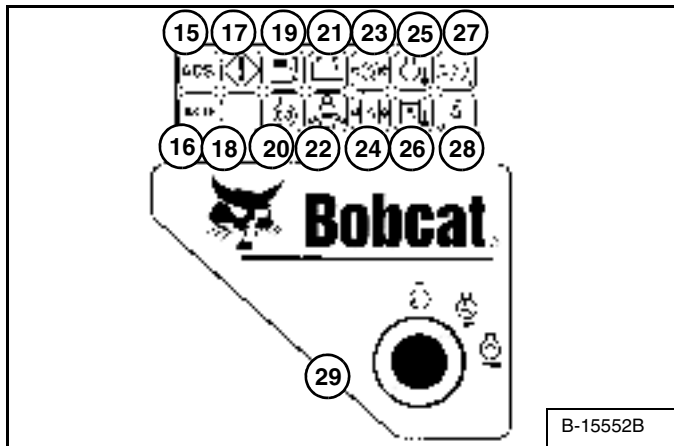

The right instrument panel shown [Figure 6] is the Key Switch Panel.

The table below shows the Icons and other components of the Right Key Switch Panel.

REF.	FUNCTION	ICON / LIGHT	ALARM	CODE	CONDITION	DESCRIPTION
15	Advanced Control System (ACS) (Opt.)	ON	3 Beeps	*	Error	Error with Advanced Control System (ACS) or Selectable Joystick Control (SJC).
16	Attachment Control Device (ACD)	ON FLASHING	--- 3 Beeps	--- *	--- Error	Electrical controlled attachment is present. Error with Attachment Control Device (ACD).
17	General Warning	ON ON FLASHING	3 Beeps 3 Beeps Continuous	* * *	Error WARNING SHUTDOWN	Error with one or more engine or hydraulic functions. Engine speed high or in shutdown. Engine speed very high. Engine will stop in 10 seconds.
18	NOT USED	---	---	---	---	---
19	Fuel Level	ON FLASHING	3 Beeps 3 Beeps	* *	Error WARNING	Fuel level sender system fault. Fuel level low.
20	Glow Plugs	ON FLASHING	--- 3 Beeps	--- *	--- Error	Glow plugs are energized. Error with glow plugs.
21	System Voltage	ON	3 Beeps	*	WARNING	Voltage low, high or very high.
22	Seat Belt	ON	---	---	---	Light stays on for 45 seconds to remind operator to fasten seat belt.
23	Engine Oil Pressure	ON ON FLASHING	3 Beeps 3 Beeps Continuous	* * *	Error WARNING SHUTDOWN	Engine oil pressure sender out of range. Engine oil level low. Engine oil pressure very low. Engine will stop in 10 seconds.
24	Hydrostatic Charge Pressure	ON ON FLASHING	3 Beeps 3 Beeps Continuous	* * *	Error WARNING SHUTDOWN	Hydraulic oil pressure sender out of range. Hydraulic oil pressure low. Hydraulic charge pressure very low. Engine will stop in 10 seconds.
25	Engine Coolant Temperature	ON ON FLASHING	3 Beeps 3 Beeps Continuous	* * *	Error WARNING SHUTDOWN	Engine coolant sender out of range. Engine coolant temperature high. Engine coolant temperature very high. Engine will stop in 10 seconds.
26	Hydraulic Oil Temperature	ON ON FLASHING	3 Beeps 3 Beeps Continuous	* * *	Error WARNING SHUTDOWN	Hydraulic oil temperature out of range. Hydraulic oil temperature high. Hydraulic oil temperature very high. Engine will stop in 10 seconds.
27	Engine Air Filter	ON FLASHING	3 Beeps 3 Beeps	* *	Error WARNING	Air filter with high restriction. Air filter switch not connected.
28	Hydraulic Filter	ON FLASHING	3 Beeps 3 Beeps	* *	Error WARNING	Hydraulic filter with high restriction. Hydraulic filter switch not connected.
29	Key Switch	---	---	---	---	Used to start and stop the engine.

\* These functions are monitored and have associated SERVICE CODES. See SYSTEM SETUP & ANALYSIS on Page 103 for description of SERVICE CODES.

## INSTRUMENT PANEL IDENTIFICATION (CONT'D)

### Right Panel (Keyless)

Figure 7

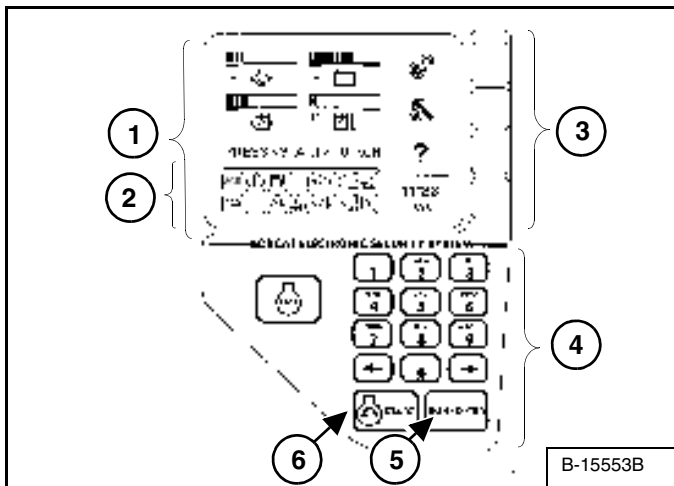

The right instrument panel shown [Figure 7] is the Keyless Panel.

1. **Display Panel:** The Display Panel is where all system setup, monitoring, troubleshooting, and error conditions are displayed.
2. **Function Icons:** The lower left area of the Keyless Panel has the same Icons as the Key Switch Panel. These Icons are only visible when the monitoring system has detected an error.
3. **Selection Buttons:** The four Selection Buttons allow you to select items from the Display Panel and scroll through screens.
4. **Keypad:** The numeric keypad (4) [Figure 7] has two functions:

To enter a number code (password) to allow starting the engine (Keyless Start).

To enter a number as directed for further use of the Display Panel.

Figure 8

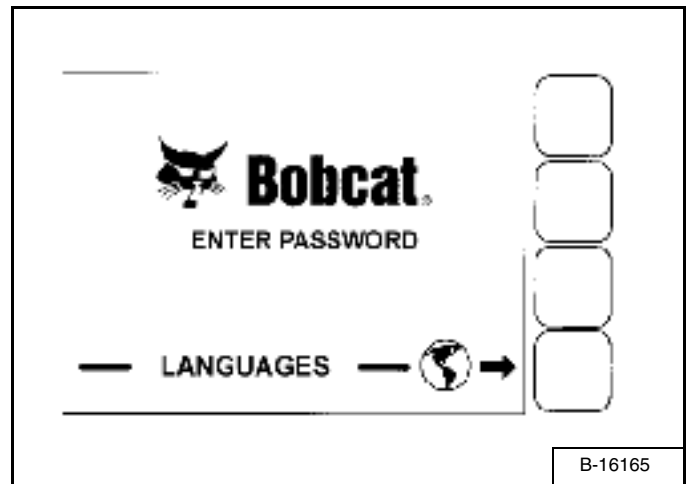

The first screen you will see on your new loader will be as shown in [Figure 8].

When this screen is on the display you can enter the password and start the engine or change the Display Panel setup features.

**NOTE: Your new loader (with Keyless Instrument Panel) will have an Owner Password. Your dealer will provide you with this password. Change the password to one that you will easily remember to prevent unauthorized use of your loader. (See Panel Setup on Page 112.) Keep your password in a safe place for future needs.**

**Start Engine:** Use the Keypad to enter the numbers (letters) of your password and press the RUN / ENTER key (5) [Figure 7].

Press and hold the START Button (6) [Figure 7] until the engine starts.

**Change Language:** Press the Selection Button at the end of the arrow [Figure 8] to go to the next screen.

## INSTRUMENT PANEL IDENTIFICATION (CONT'D)

### Right Panel (Keyless) (Cont'd)

Figure 9

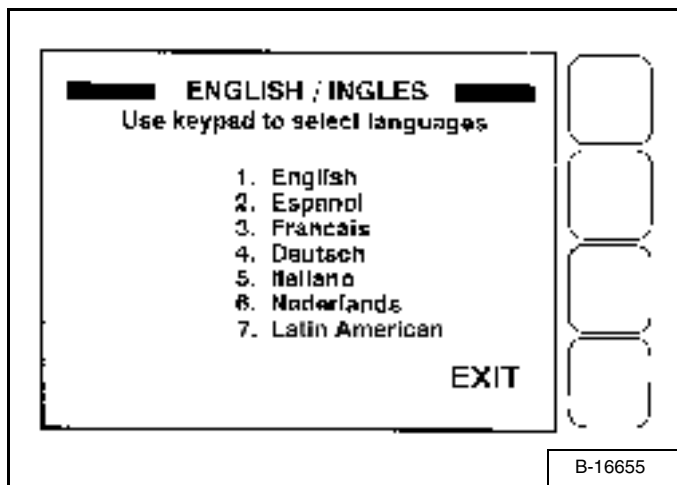

Use the Keypad to select the number of the language [Figure 9].

Press EXIT. The screen will return to [Figure 8]. You can then enter the password and start the engine.

(See DISPLAY CONTROLLER PANEL SETUP on Page 111) for further description of screens to setup the system for your use.

**NOTE:** Pressing the EXIT key will go to the previous screen and you can continue pressing until you get to the initial (home) screen.  
**SHORTCUT:** Press the "0" (zero) key to get to the home screen immediately.

## Cab Light

Figure 10

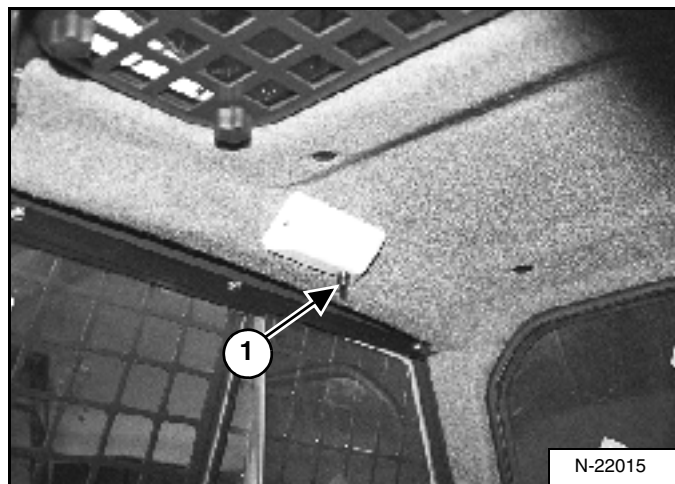

Push the button (1) [Figure 10] to turn the light ON. Push the button again to turn OFF.

## INSTRUMENT PANEL IDENTIFICATION (CONT'D)

### Option And Field Accessory Panels

Figure 11

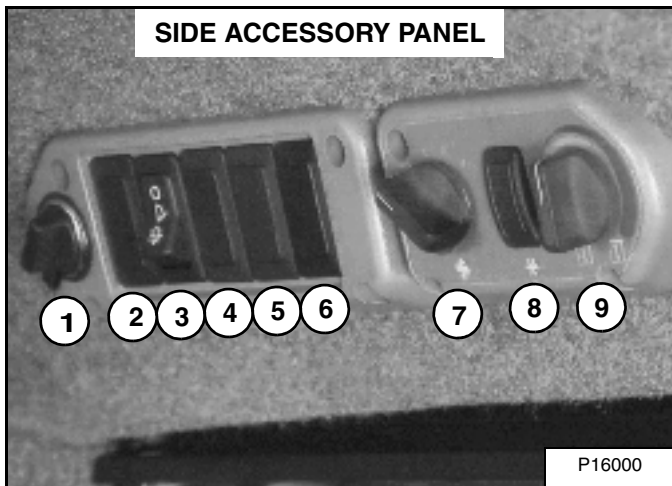

Side Accessory Panel [Figure 11]

REF. NO.	DESCRIPTION	FUNCTION / OPERATION
1	POWER PLUG	Provides a 12V receptacle for accessories.
2	NOT USED	- - -
3	FRONT WIPER	Press the top of the switch to start the front wiper (press and hold for washer fluid). Press the bottom of the switch to stop the wiper.
4	REAR WIPER	Press the bottom of the switch to start the rear wiper. Press the top of the switch to provide washer fluid to clean the rear window.
5	NOT USED	- - -
6	NOT USED	- - -
7	FAN MOTOR	Turn clockwise to increase fan speed; counterclockwise to decrease. There are four positions; OFF-1-2-3.
8	AIR COND. SWITCH	Press top of switch to start; bottom to stop. Fan Motor (7) must be ON for A/C to operate.
9	TEMP. CONTROL	Turn clockwise to increase the temperature; counterclockwise to decrease.

Figure 12

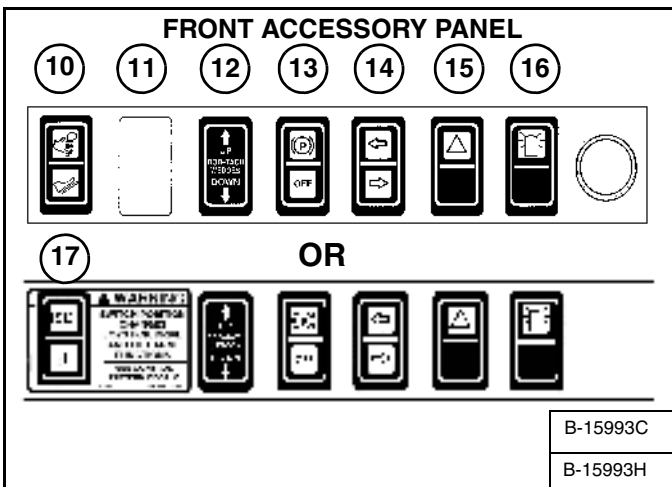

Front Accessory Panel [Figure 12]

REF. NO.	DESCRIPTION	FUNCTION / OPERATION
10	ADVANCED CONTROL SYSTEM (ACS)	Press the top to select Hand Controls; bottom to select Foot Controls.
11	NOT USED	- - -
12	POWER BOB-TACH	Press and hold the up arrow to disengage the the Bob-Tach wedges. Press and hold the down arrow to engage the wedges into the mounting frame holes.
13	PARKING BRAKE (Standard on all Loaders)	Press the top to engage the PARKING BRAKE; bottom to disengage.
14	TURN SIGNAL INDICATORS	Indicates left or right TURN SIGNALS are ON.
15	HAZARD LIGHTS	Press the top to turn the HAZARD LIGHTS ON; right side bottom to turn OFF.
16	ROTATING BEACON	Press the top to turn the ROTATING BEACON ON; bottom to turn OFF.
17	SELECTABLE JOYSTICK CONTROL (SJC)	Press the top to select 'ISO' Control Pattern; bottom to select 'H' Control Pattern.

**NOTE:** Parking Brake (13) [Figure 12] is Standard on all loaders.

## SEAT BAR RESTRAINT SYSTEM

### Operation

Figure 13

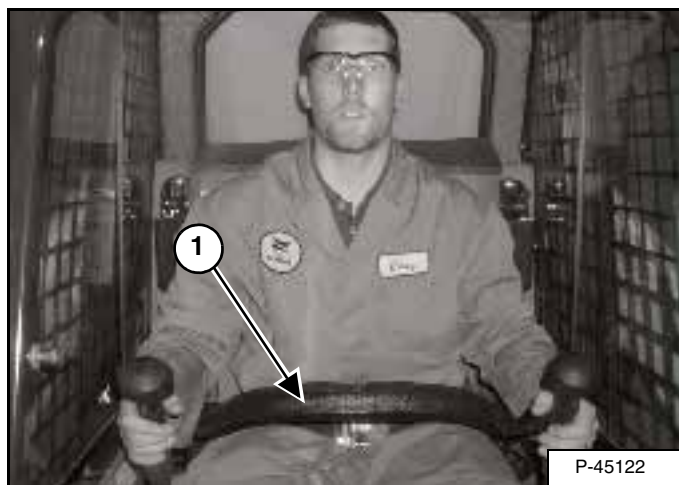

The seat bar restraint system has a pivoting seat bar with arm rests (1) [Figure 13].

The operator controls the use of the seat bar. The seat bar in the down position helps to keep the operator in the seat.

## **WARNING**

### **AVOID INJURY OR DEATH**

**When operating the machine:**

- **Keep the seat belt fastened snugly.**
- **The seat bar must be lowered.**
- **Keep your feet on the pedal controls or footrests and hands on steering levers.**

W-2261-0799

When the seat bar is down, PRESS TO OPERATE LOADER Button is activated, and the brake is released, the lift, tilt, and traction drive functions can be operated. (Traction drive will operate only when the engine is running.)

When, the seat bar is up, the lift, tilt, and traction drive functions are deactivated and both foot pedals (if equipped) will be locked when returned to neutral position.

## **WARNING**

**Before you leave the operator's seat:**

- **Lower the lift arms, put the attachment flat on the ground.**
- **Stop the engine.**
- **Engage the parking brake.**
- **Raise seat bar.**
- **(Foot Pedal Controls) Move pedals until both lock.**
- **(Advanced Control system - ACS) Move the hydraulic controls to the NEUTRAL POSITION to make sure that both lift and tilt functions are deactivated.**  
The seat bar system must deactivate the lift and tilt control functions when the seat bar is up. Service the system if hand controls do not deactivate.
- **(Selectable Joystick Controls - SJC) Move the joysticks to the NEUTRAL POSITION to make sure that travel and hydraulic functions are deactivated.**  
The seat bar system must deactivate these functions when the seat bar is up. Service the system if controls do not deactivate.

W-2463-0603

## BOBCAT INTERLOCK CONTROL SYSTEM (BICS)

### Operation



#### AVOID INJURY OR DEATH

The Bobcat Interlock Control System (BICS) must deactivate the lift, tilt and traction drive functions. If it does not, contact your dealer for service. DO NOT modify the system.

W-2151-0394

Figure 14



The Bobcat Interlock Control System (BICS) has a pivoting seat bar with arm rests (1) [Figure 14].

The operator controls the use of the seat bar. The seat bar in the down position helps to keep the operator in the seat.

The BICS requires the operator to be seated in the operating position with the Seat Bar (1) [Figure 14] fully lowered before the lift, tilt, auxiliary hydraulics, and traction functions can be operated. The seat belt must be fastened anytime you operate the machine.



#### AVOID INJURY OR DEATH

When operating the machine:

- Keep the seat belt fastened snugly.
- The seat bar must be lowered.
- Keep your feet on the pedal controls or footrests and hands on steering levers.

W-2261-0799

Figure 15

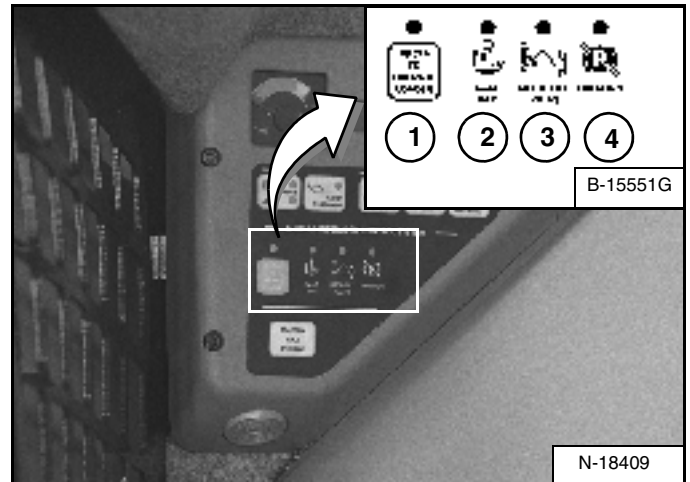

There are display lights (1, 2, 3 and 4) [Figure 15] located on the left instrument panel that must be ON to operate the machine.

When the seat bar is down, PRESS TO OPERATE LOADER Button is activated, and the parking brake is released, the lift, tilt, auxiliary hydraulics, and traction drive functions can be operated.

When, the seat bar is up, the lift, tilt, auxiliary hydraulics, and traction drive functions are deactivated.



Before you leave the operator's seat:

- Lower the lift arms, put the attachment flat on the ground.
- Stop the engine.
- Engage the parking brake.
- Raise seat bar.
- (Foot Pedal Controls) Move pedals until both lock.
- (Advanced Control system - ACS) Move the hydraulic controls to the NEUTRAL POSITION to make sure that both lift and tilt functions are deactivated.

The seat bar system must deactivate the lift and tilt control functions when the seat bar is up. Service the system if hand controls do not deactivate.

- (Selectable Joystick Controls - SJC) Move the joysticks to the NEUTRAL POSITION to make sure that travel and hydraulic functions are deactivated.

The seat bar system must deactivate these functions when the seat bar is up. Service the system if controls do not deactivate.

W-2463-0603

## LIFT ARM BY-PASS CONTROL

Figure 16

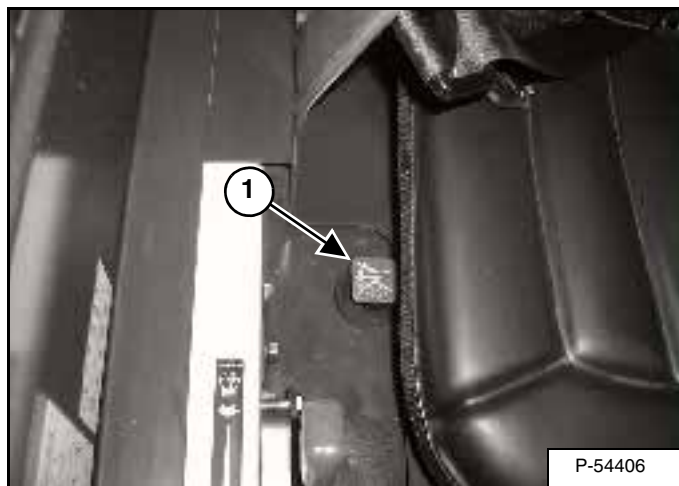

The lift arm by-pass control (1) [Figure 16] is used to lower the lift arms if the lift arms cannot be lowered during normal operations.

- Sit in the operator's seat.
- Fasten the seat belt and lower the seat bar.
- Turn the knob (1) [Figure 16] clockwise 1/4 turn.
- Pull up and hold the knob until the lift arms slowly lower.

## TRACTION LOCK OVERRIDE

### Operation

Figure 17

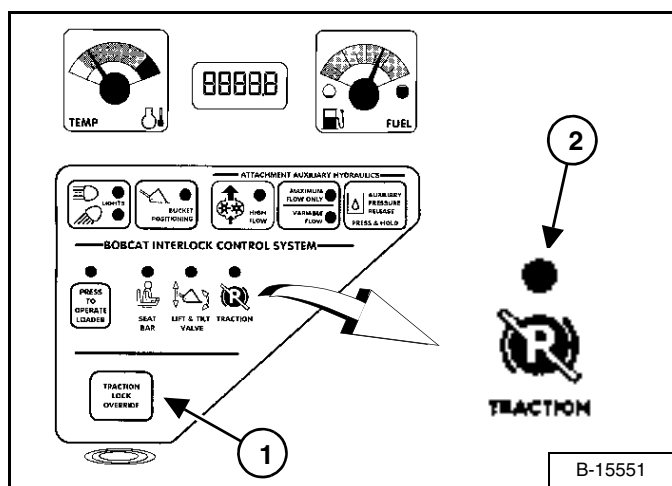

(Functions Only When The Seat Bar Is Raised And The Engine Is Running) There is a TRACTION LOCK OVERRIDE Button (1) [Figure 17] on the left instrument panel which will allow you to use the steering levers to move the loader forward & backward when using the backhoe attachment or for loader service.

Press the TRACTION LOCK OVERRIDE Button once to unlock traction drive. The TRACTION light (2) [Figure 17] will be ON.

Press the button a second time to lock the traction drive. The TRACTION light (2) [Figure 17] will be OFF.

**NOTE: The TRACTION LOCK OVERRIDE Button will unlock the traction drive when seat bar is raised and the engine is running.**

**The TRACTION LOCK OVERRIDE Button will function if brake is in the engaged or disengaged position and the engine is running.**



## ENGINE SPEED CONTROL

### Operation

Figure 18

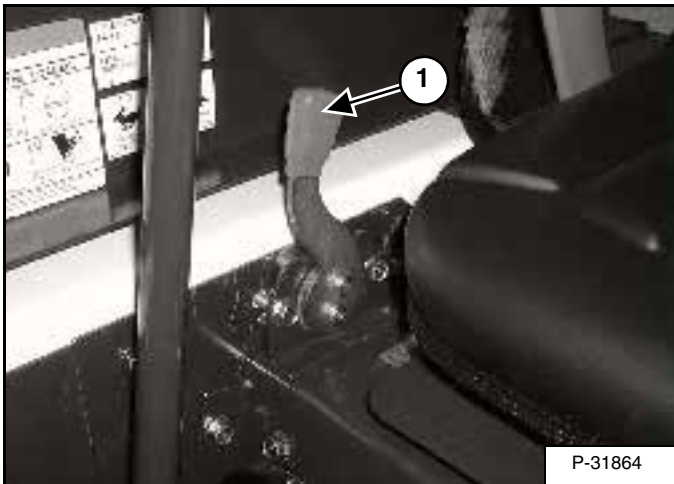

The speed control lever is at the right side of the operator's seat (1) [Figure 18].

Move the lever forward to increase engine speed. Move backward to decrease engine speed.

## PARKING BRAKE

Figure 19

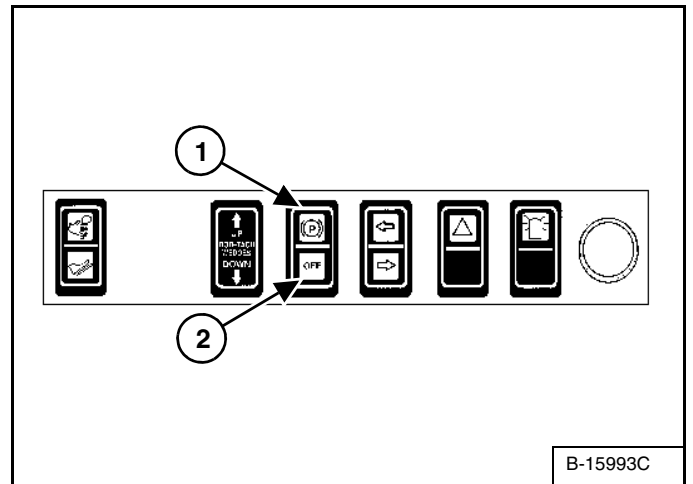

Press the top of the switch (1) [Figure 19] to engage the parking brake. The traction drive system will be locked.

Press the bottom of the switch (2) [Figure 19] to disengage the parking brake. The traction drive system will be unlocked.

**NOTE:** The TRACTION light on the left instrument panel will remain OFF until the engine is started, the PRESS TO OPERATE LOADER Button is pressed and the parking brake is disengaged.

## DRIVING AND STEERING THE LOADER

### Available Controls Configurations

The loader has three configurations available:

- *Standard Controls* - Two Steering Levers control drive and steering functions.
- *Advanced Control System (ACS) (Option or Field Accessory)* - Two Steering Levers control drive and steering functions.
- *Selectable Joystick Controls (SJC) (Option) - ('ISO' Pattern)* - Left joystick controls the drive and steering functions.

*('H' Pattern)* Left and right joysticks control left and right side drive and steering functions.

### Operation (Standard and ACS)

Figure 20

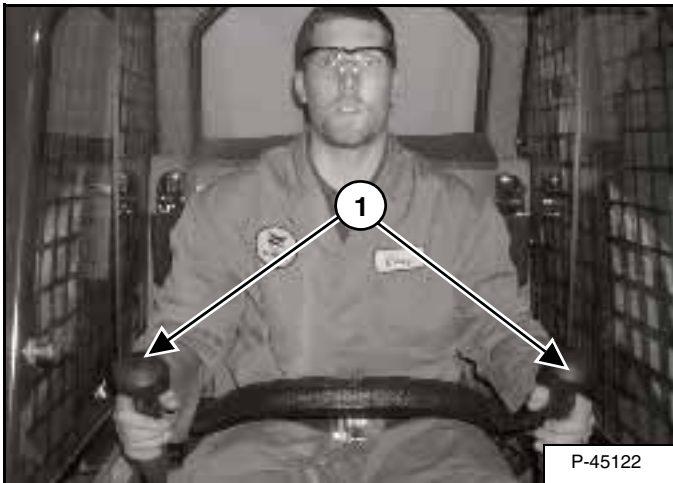

The control levers (1) [Figure 20] are on the left and right side in front of the seat.

Move levers smoothly. Avoid sudden starting and stopping.

## **WARNING**

### **AVOID INJURY OR DEATH**

**When operating the machine:**

- **Keep the seat belt fastened snugly.**
- **The seat bar must be lowered.**
- **Keep your feet on the pedal controls or footrests and hands on steering levers.**

W-2261-0799

Figure 21

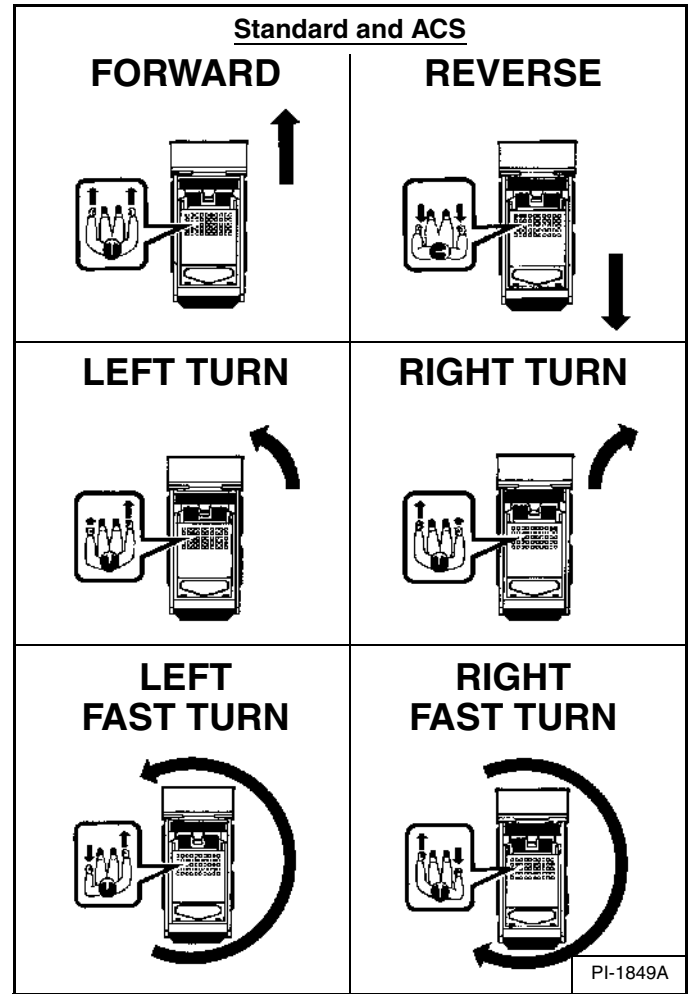

The levers control forward and reverse travel and turning the loader [Figure 21].

**Forward Travel** - Push both levers forward.

**Reverse Travel** - Pull both levers backward.

**Normal Turning** - Move one lever farther forward than the other.

**Fast Turning** - Push one lever forward and pull the other lever backward.

For slow travel speed, push the steering levers forward only a small amount.

To increase travel speed, push both levers farther forward.

For maximum pushing force, push the levers forward only a small amount with the engine at full speed.

## DRIVING AND STEERING THE LOADER (CONT'D)

### Operation (SJC) in 'H' Control Pattern

Figure 22

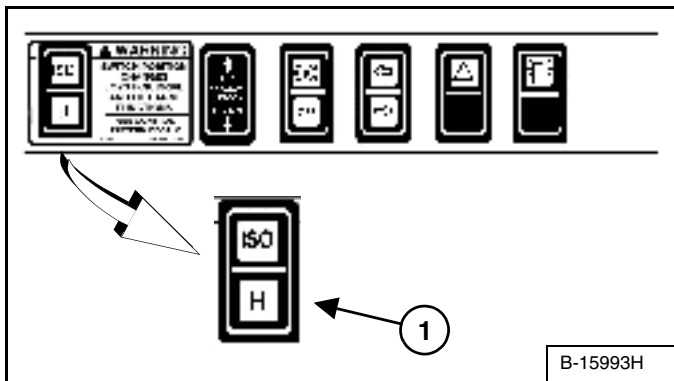

Select the 'H' control pattern by pressing the bottom of the switch (1) [Figure 22].



## WARNING

### AVOID INJURY OR DEATH

When operating the machine:

- Keep the seat belt fastened snugly.
- The seat bar must be lowered.
- Keep your feet on the foot rests and hands on control levers.

W-2399-0501

Figure 23

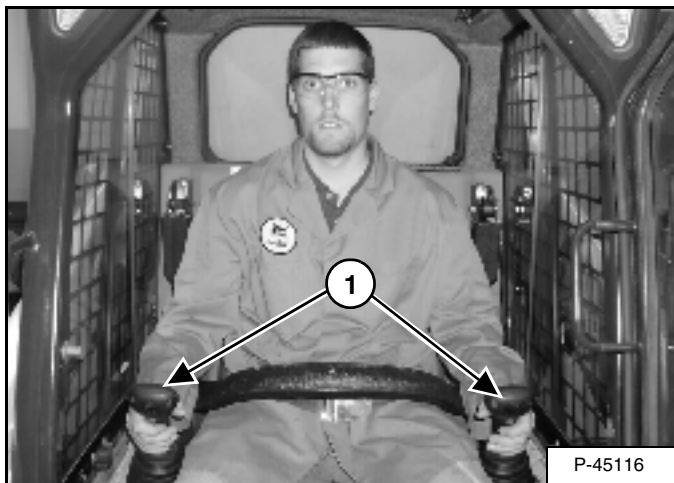

Both joysticks control drive and steering and are located on the right and left side in front of the seat (1) [Figure 23].

Move the joysticks smoothly. Avoid sudden starting and stopping.

Figure 24

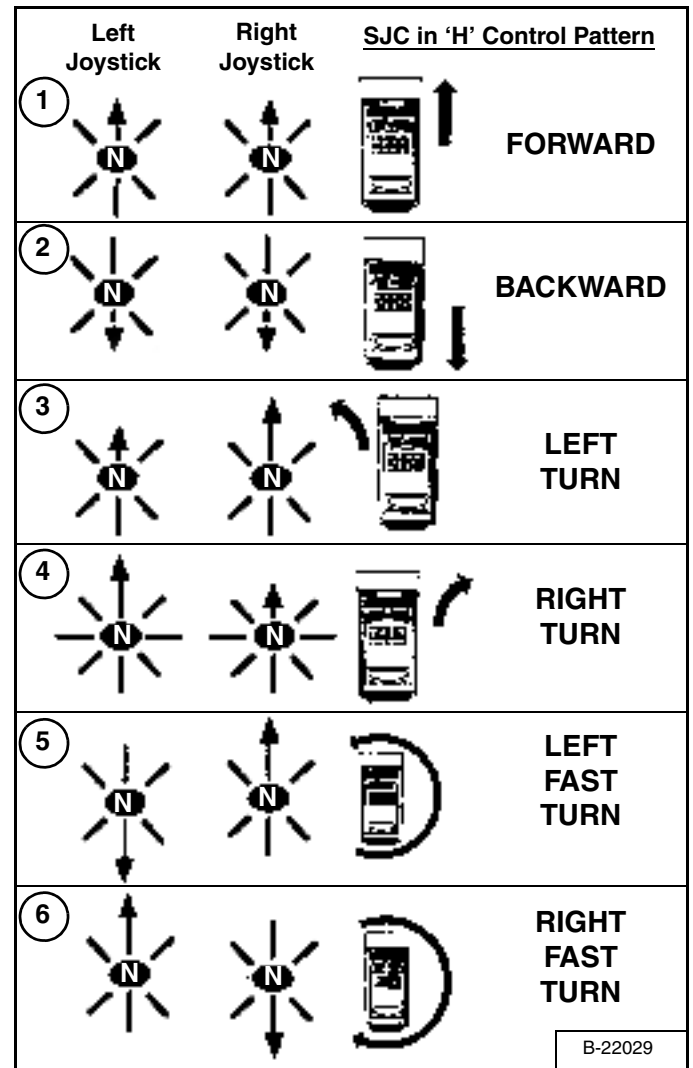

*Hand Control Functions (Drive and Steering)* [Figure 24]

1. **Forward Travel** - Move both joysticks forward.
2. **Backward Travel** - Move both joysticks backward.
3. **Forward Left Turn** - Move the right joystick farther forward than the left joystick.
4. **Forward Right Turn** - Move the left joystick farther forward than the right joystick.
5. **Left Fast Turn** - Move the left joystick backward and the right joystick forward.
6. **Right Fast Turn** - Move the left joystick forward and the right joystick backward.

## DRIVING AND STEERING THE LOADER (CONT'D)

### Operation (SJC) in 'ISO' Control Pattern

Figure 25

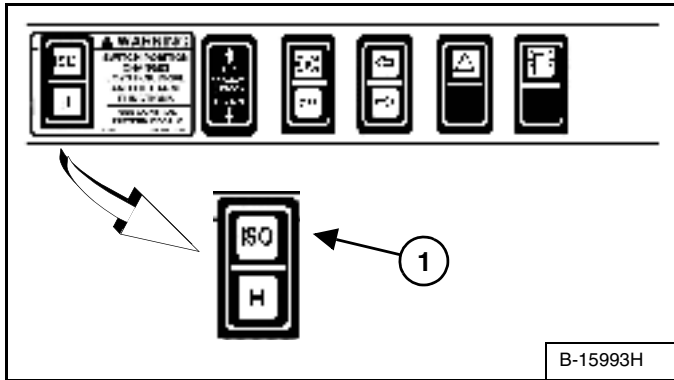

Select the 'ISO' control pattern by pressing the top of the switch (1) [Figure 25].



#### AVOID INJURY OR DEATH

When operating the machine:

- Keep the seat belt fastened snugly.
- The seat bar must be lowered.
- Keep your feet on the foot rests and hands on control levers.

W-2399-0501

Figure 26

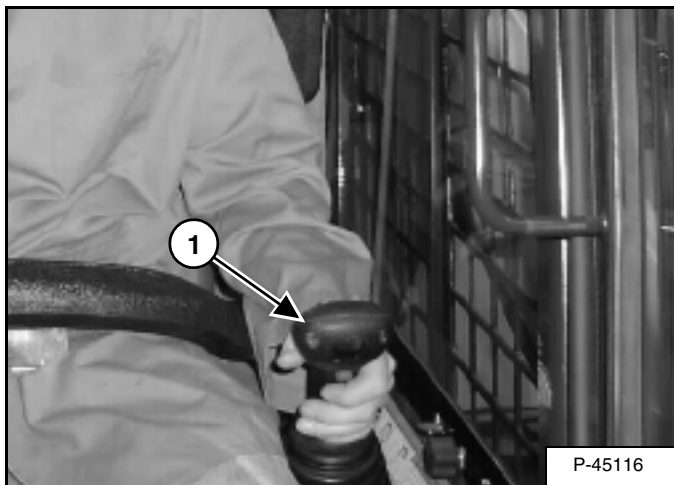

The joystick which controls drive and steering is on the left side in front of the seat (1) [Figure 26].

Figure 27

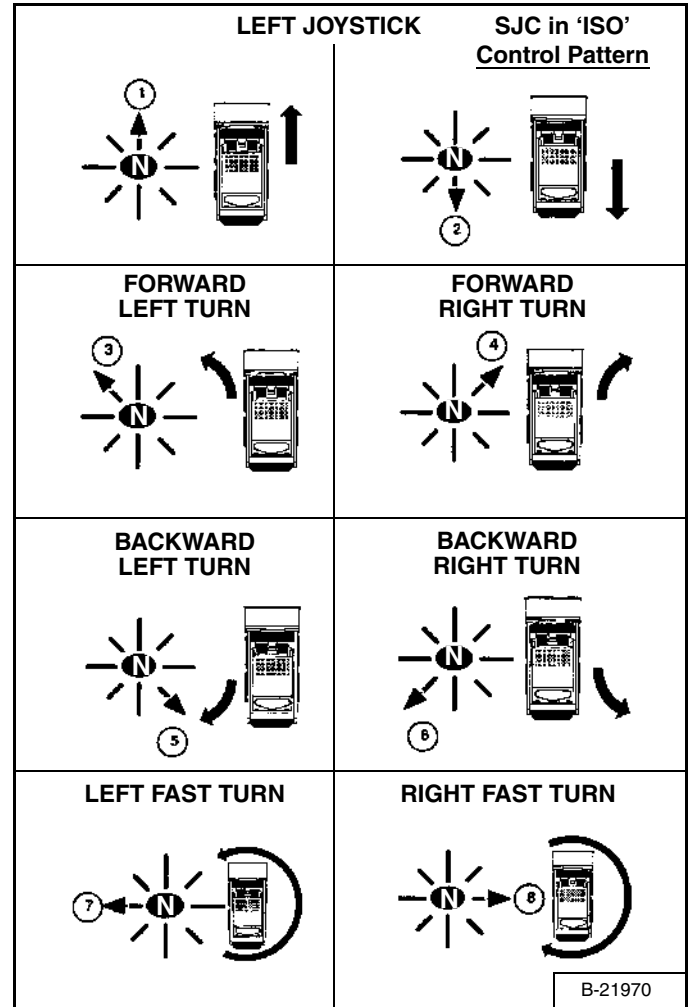

### Left Joystick Functions (Drive and Steering) [Figure 27]

Move the joystick smoothly. Avoid sudden starting and stopping.

1. **Forward Travel** - Move joystick forward.
2. **Backward Travel** - Move joystick backward.
3. **Forward Left Turn** - Move joystick forward and to the left.
4. **Forward Right Turn** - Move joystick forward and to the right.
5. **Backward Left Turn** - Move joystick backward and to the right.
6. **Backward Right Turn** - Move joystick backward and to the left.
7. **Left Fast Turn** - Move joystick to the left.
8. **Right Fast Turn** - Move joystick to the right.

## STOPPING THE LOADER

### Using The Control Levers Or Joysticks

When the control levers or joysticks are moved to the neutral position, the hydrostatic transmission will act as a *service brake* to stop the loader.

## SPEED MANAGEMENT (SJC OPTION)

### Operation

Speed Management allows the loader to be maneuvered at slow travel speed for installing attachments, loading or unloading, and work applications such as trenching, tilling and landscaping.

Figure 28

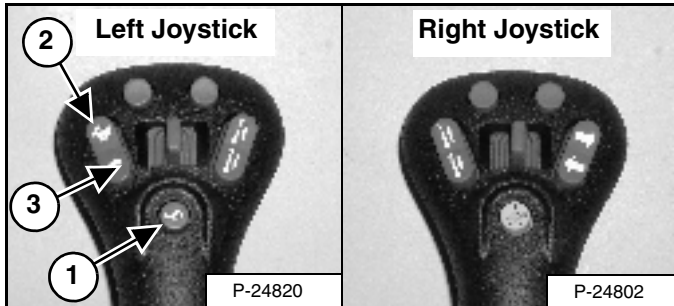

Press the button (1) [Figure 28] on the left joystick once to engage Speed Management.

Figure 29

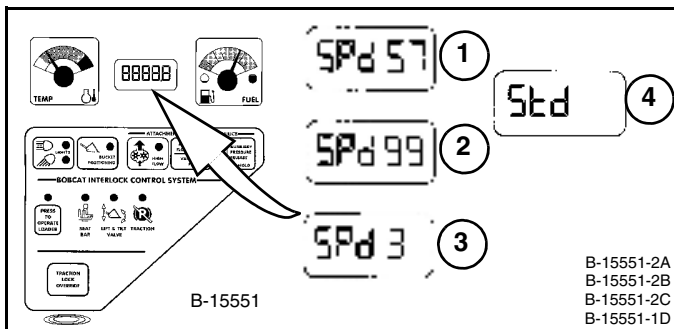

When Speed Management is engaged, the machine will travel at 57% of Standard travel speed and the percentage [SPd 57] will appear in the display (1) [Figure 29].

While Speed Management is engaged, press the top of the Speed Control switch (2) [Figure 28] to increase the speed up to 99% [SPd 99] or the bottom of the switch (3) [Figure 28] to decrease the speed down to 3% [SPd 3]. The percentages will appear in the display (1, 2 and 3) [Figure 29].

Press button (1) [Figure 28] again to disengage Speed Management and return to Standard Travel Speed ([Std] (4) [Figure 29] will appear in display.)

**NOTE:** Early model loaders will show Snl in the display [Figure 29] instead of SPd.

The system will retain the speed percentage as long as the key remains ON (Key Switch Panel) or the STOP button has not been pressed (Keyless Panel).

**EXAMPLE:** You can be using the machine at 40% and then disengage Speed Management to reposition the loader, then re-engage Speed Management. The speed percentage will still be at 40%.

**EXAMPLE:** If you turn the key OFF or press the STOP button, the next time you start the engine and engage Speed Management, the speed will be at 57% of Standard Travel Speed. Press button (1) [Figure 28] to resume Speed Management Operation.

## HYDRAULIC CONTROLS

### Description

Two foot pedals (or optional hand controls) control the hydraulic cylinders for the lift and tilt functions.

Put your feet on the pedals (or footrests) and **KEEP THEM THERE** any time you operate the loader.

### Standard Controls (Also ACS In FOOT Pedal Mode)

**Figure 30**

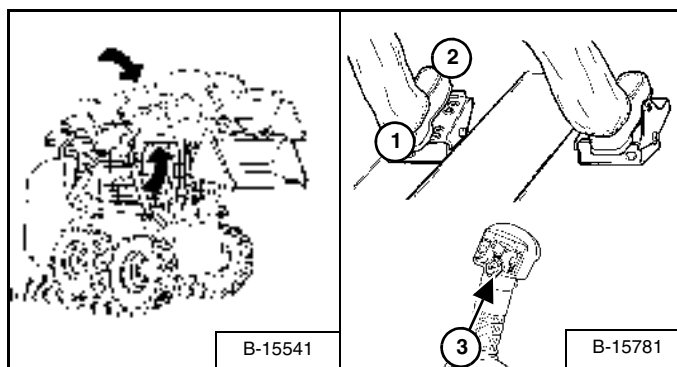

#### Lift Arm Operation - (Left Pedal)

Push the heel (1) **[Figure 30]** of the pedal to raise the lift arms.

Push the toe (2) **[Figure 30]** of the pedal to lower the lift arms.

#### Lift Arm Float Position Operation - (Left Pedal)

Push the toe (2) **[Figure 30]** of the pedal all the way forward until it locks into the float position.

Use the float position of the lift arms to level loose material while driving backward.

Raise the lift arms to disengage the float position.

#### Lift Arm Float Position (With ACS) - (Left Pedal)

Press and hold the Float button (3) **[Figure 30]**.

Push the toe (2) **[Figure 30]** of the pedal forward to lower the lift arms. Then release the float button.

Use the float position of the lift arms to level loose material while driving backward.

Raise the lift arms to disengage the float position.

**Figure 31**

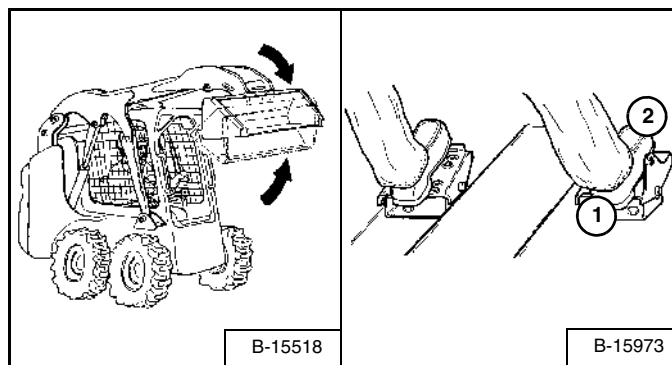

#### Tilt Operation - (Right Pedal)

Push the heel (1) **[Figure 31]** of the pedal to tilt the bucket backward.

Push the toe (2) **[Figure 31]** of the pedal to tilt the bucket forward.

## HYDRAULIC CONTROLS (CONT'D)

### Advanced Control System (ACS) In HAND Control Mode

Figure 32

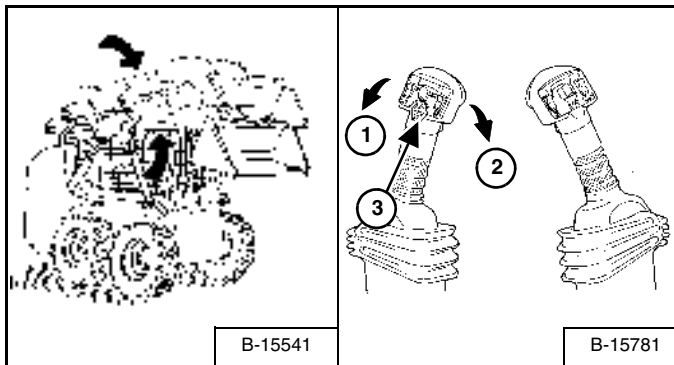

#### Lift Arm Operation - (Left Hand Lever)

Move the lever outward (1) [Figure 32] to raise the lift arms.

Move the lever inward (2) [Figure 32] to lower the lift arms.

#### Lift Arm Float Position - (Left Hand Lever)

Press and hold the Float Button (3) [Figure 32] while the lever is in neutral. Move the lever to lift arm down position (2) [Figure 32], then release the button.

Press Float Button (3) [Figure 32] again or move the lever to lift arm up position (1) [Figure 32].

Use the float position of the lift arms to level loose material while driving backward.

Figure 33

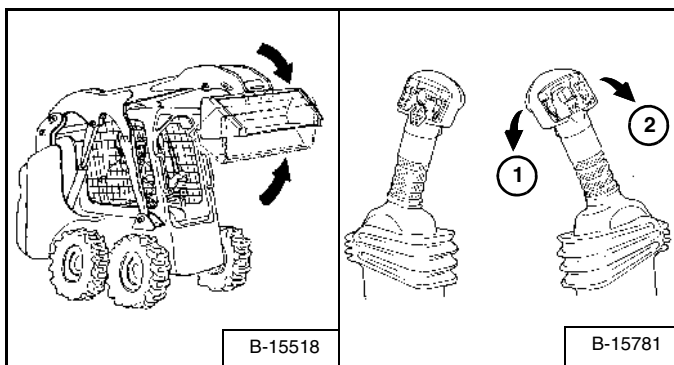

#### Tilt Operation - (Right Hand Lever)

Move the lever inward (1) [Figure 33] to tilt the bucket backward.

Move the lever outward (2) [Figure 33] to tilt the bucket forward.

### Selectable Joystick Control (SJC) In 'H' Control Pattern

Figure 34

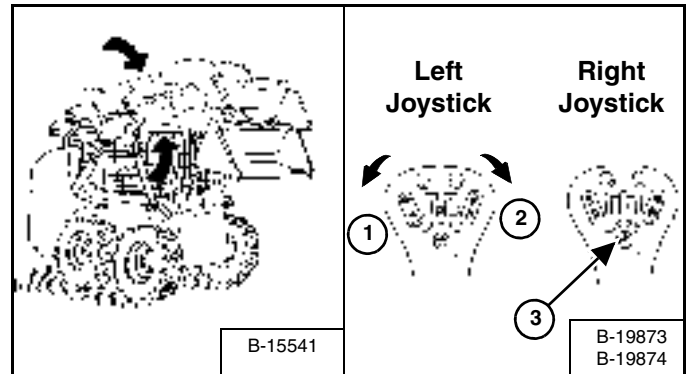

#### Lift Arm Operation - (Left Hand Joystick)

Move the joystick outward (1) [Figure 34] to raise the lift arms.

Move the joystick inward (2) [Figure 34] to lower the lift arms.

#### Lift Arm Float Position - (Left & Right Hand Joysticks)

Press and hold the Float Button (3) [Figure 34] while the joysticks are in neutral. Move the left joystick to lift arm down position (2) [Figure 34], then release the button.

Press Float Button (3) [Figure 34] again or move the left joystick to lift arm up position (1) [Figure 34] to disengage.

Use the float position of the lift arms to level loose material while driving backward.

Figure 35

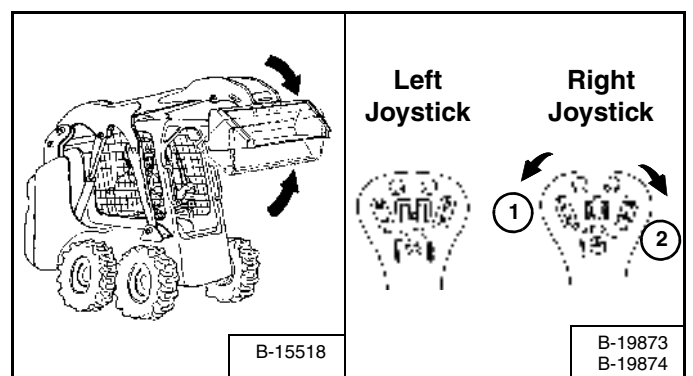

#### Tilt Operation - (Right Hand Joystick)

Move the joystick inward (1) [Figure 35] to tilt the bucket backward.

Move the joystick outward (2) [Figure 35] to tilt the bucket forward.

## HYDRAULIC CONTROLS (CONT'D)

### Selectable Joystick Control (SJC) In 'ISO' Control Pattern

Figure 36

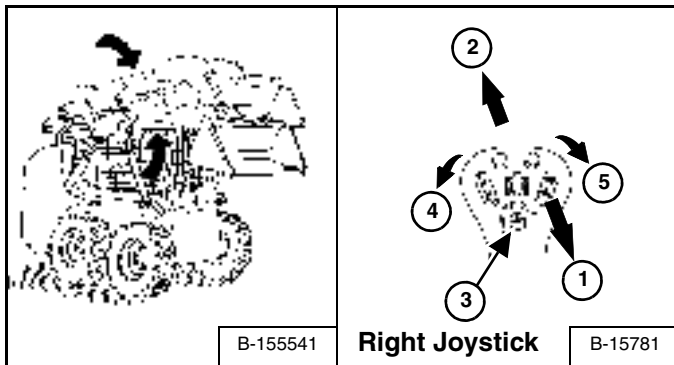

#### Lift Arm Operation - (Right Hand Joystick)

Move the joystick backward (1) [Figure 36] to raise the lift arms.

Move the joystick forward (2) [Figure 36] to lower the lift arms.

#### Lift Arm Float Position - (Right Hand Joystick)

Press and hold the Float Button (3) [Figure 36] while the joystick is in neutral. Move the joystick to lift arm down position (2) [Figure 36], then release the button.

Press Float Button (3) [Figure 36] again or move the joystick to lift arm up position (1) [Figure 36] to disengage.

Use the float position of the lift arms to level loose material while driving backward.

Figure 37

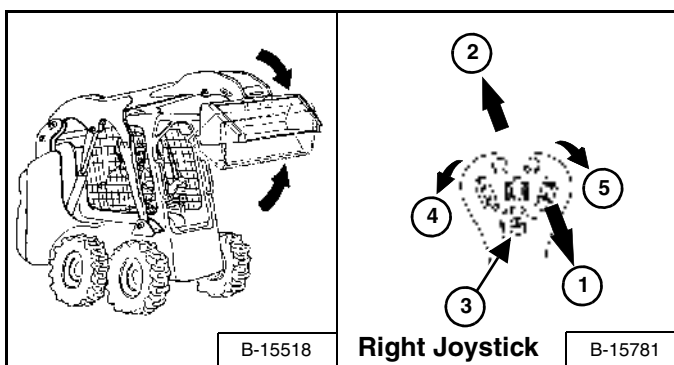

#### Tilt Operation - (Right Hand Joystick)

Move the joystick inward (4) [Figure 37] to tilt the bucket backward.

Move the joystick outward (5) [Figure 37] to tilt the bucket forward.

### Bucket Position Valve Operation (If Equipped)

The function of the bucket position valve is to keep the bucket in the same approximate position it is in before you begin raising the lift arms.

Figure 38

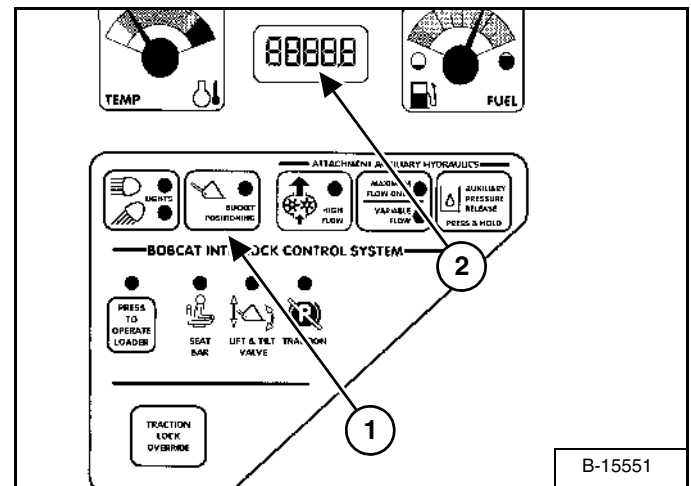

Press BUCKET POSITIONING button (1) [Figure 38] to engage the bucket position function. (The light will be on.) Press again to disengage.

Bucket Positioning functions only during upward lift cycle.

If the Bucket Positioning button is pressed and held for 2 seconds, the Warning and Shutdown status will be displayed (2) [Figure 38]. (See SHUTDOWN FEATURE on Page 115.)



## HYDRAULIC CONTROLS (CONT'D)

### Auxiliary Hydraulics Operation (VARIABLE FLOW)

Figure 39

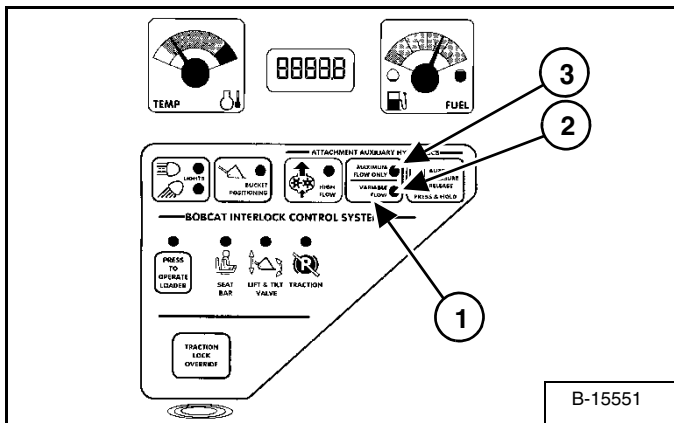
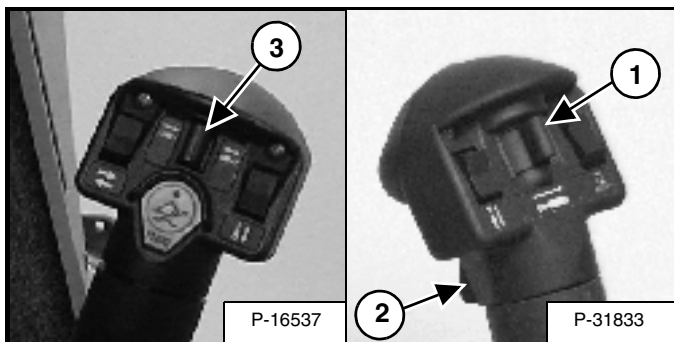

Figure 40



*VARIABLE FLOW* allows for slow-to-fast movement of auxiliary functions. If you move the auxiliary switch (1) [Figure 40] half-way, the auxiliary functions move at approximately one-half speed.

Press the auxiliary hydraulics button (1) [Figure 39] once.

The light (2) [Figure 39] will be ON.

To disengage, press the auxiliary hydraulics button (1) [Figure 39] two more times.

Both lights (2 and 3) [Figure 39] will be OFF.

**NOTE:** When the operator is seated and raises the seat bar, the Auxiliary Hydraulic System (Front and Rear) will deactivate.

### Auxiliary Hydraulics Operation (MAXIMUM FLOW ONLY)

*MAXIMUM FLOW ONLY* allows for fast movement only. If you move the auxiliary switch (1 or 3) [Figure 40], the auxiliary functions move at fast speed; release the switch to stop auxiliary functions.

Press the auxiliary hydraulics button (1) [Figure 39] two times.

The light (3) [Figure 39] will be ON.

To disengage, press the auxiliary hydraulics button (1) [Figure 39] again.

Both lights (2 and 3) [Figure 39] will be OFF.

**NOTE:** When the operator is seated and raises the seat bar, the Auxiliary Hydraulic System (Front and Rear) will deactivate.

### FRONT Auxiliary Hydraulics Operation (VARIABLE FLOW)

Press the auxiliary hydraulics button for VARIABLE FLOW.

Push the switch (1) [Figure 40] to the right or left to change the fluid flow direction of the front quick couplers. (EXAMPLE: Open and close grapple teeth.)

### FRONT Auxiliary Hydraulics Operation (MAXIMUM FLOW)

Press the auxiliary hydraulics button for MAXIMUM FLOW.

Push the switch (1) [Figure 40] to the right or left to change the fluid flow direction of the front quick couplers. (EXAMPLE: Open and close grapple teeth.)

Press again to disengage.

## HYDRAULIC CONTROLS (CONT'D)

### FRONT Auxiliary Hydraulics Operation (CONTINUOUS FLOW)

After selecting VARIABLE or MAXIMUM FLOW, press the front switch (2) [Figure 40] to give the front quick couplers a constant flow of fluid with the female coupler being pressurized. (EXAMPLE: Operate a backhoe.)

*REVERSE CONTINUOUS FLOW* - To set reverse flow (male coupler pressurized), select VARIABLE or MAXIMUM FLOW, then, while holding the auxiliary switch (1) [Figure 40] to the left, press the front switch (2) [Figure 40]. Reverse flow can be used only with augers, power rakes, sweepers, tillers, and vibratory rollers.

To release from continuous operation, press the front switch (2) [Figure 40] a second time.

### REAR Auxiliary Hydraulics Operation (If Equipped)

Figure 41



The switches on the left hand lever control the rear auxiliary hydraulics.

Press the auxiliary hydraulics button for MAXIMUM FLOW.

Push the switch (3) [Figure 40] to the right or left to change the fluid flow direction to rear quick couplers [Figure 41]. (EXAMPLE: Raise and lower rear stabilizers.)

## Quick Couplers

### **WARNING**

**Diesel fuel or hydraulic fluid under pressure can penetrate skin or eyes, causing serious injury or death. Fluid leaks under pressure may not be visible. Use a piece of cardboard or wood to find leaks. Do not use your bare hand. Wear safety goggles. If fluid enters skin or eyes, get immediate medical attention from a physician familiar with this injury.**

W-2072-0496

Figure 42

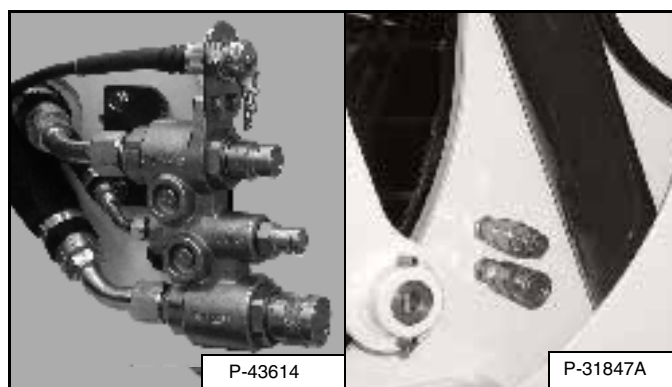

*To Connect:* Remove dirt or debris from the surface of both the male and female couplers, and from the outside diameter of the male coupler. Visually check the couplers for corroding, cracking, damage or excessive wear. If any of these conditions exist, the coupler(s) [Figure 42] must be replaced.

Install the male coupler into the female coupler. Full connection is made when the ball release sleeve slides forward on the female coupler.

*To Disconnect:* Hold the male coupler. Retract the sleeve on the female coupler until the couplers disconnect.

## HYDRAULIC CONTROLS (CONT'D)

### Relieve Hydraulic Pressure (Loader and Attachment)



#### AVOID BURNS

Hydraulic fluid, tubes, fittings and quick couplers can get hot when running machine and attachments. Be careful when connecting and disconnecting quick couplers.

W-2220-0396

#### Front Auxiliary Quick Couplers

*When Connecting:* Push the quick couplers tightly together and hold for five seconds; the pressure is automatically released as the couplers are installed.

*When Disconnecting:* Push the quick couplers tightly together and hold for five seconds; then retract the sleeve until the couplers disconnect.

#### Rear Auxiliary Quick Couplers

Figure 43

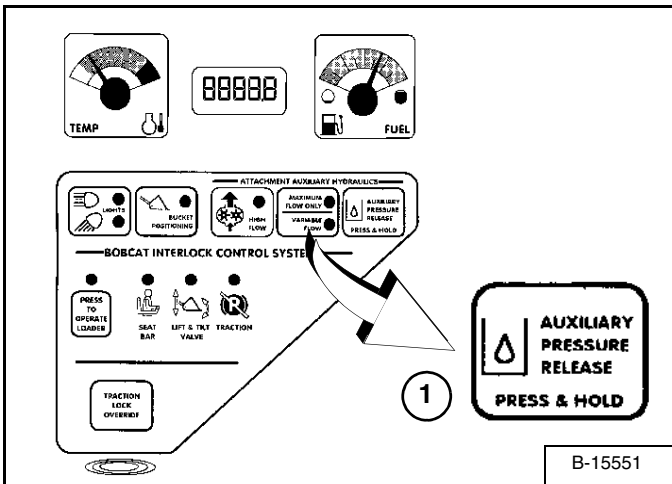

Press the AUXILIARY PRESSURE RELEASE Button (1) [Figure 43]. Hold it for two seconds after the engine comes to a complete stop. The pressure will be released.

## High-Flow Hydraulics Operation (If Equipped)

Figure 44

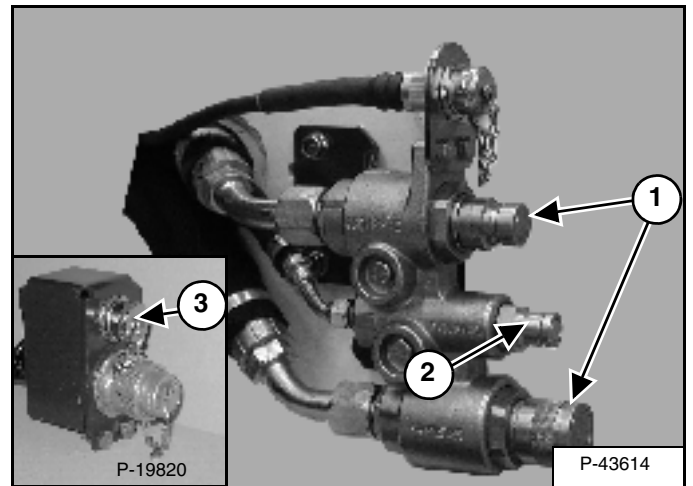

The High-Flow function provides additional flow to the system to operate an attachment which requires more hydraulic flow (EXAMPLE: Planer).

Connect the attachment to the quick couplers (1) [Figure 44].

Some attachments may have a case drain which needs to be connected to the small quick coupler (2) [Figure 44].

Figure 45

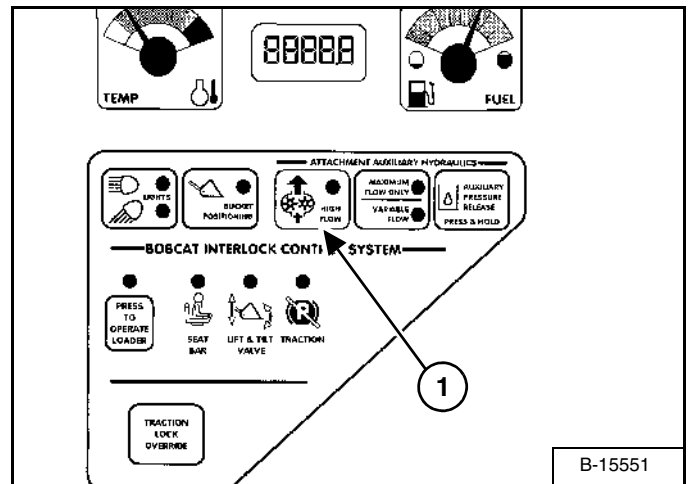

Press the HIGH FLOW button (1) [Figure 45].

Press a second time to disengage.

## HYDRAULIC CONTROLS (CONT'D)

### High-Flow Hydraulics Operation (If Equipped) (Cont'd)

Figure 46

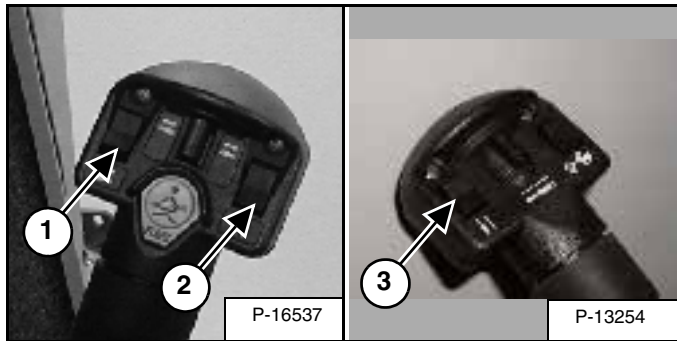

You can use additional switches (1, 2, and 3) [Figure 46] on the right and left control handles for functions which control some attachments.

See the appropriate Attachment Operation & Maintenance Manual for control details.

### Attachment Control Device (ACD) (If Equipped)

Figure 47

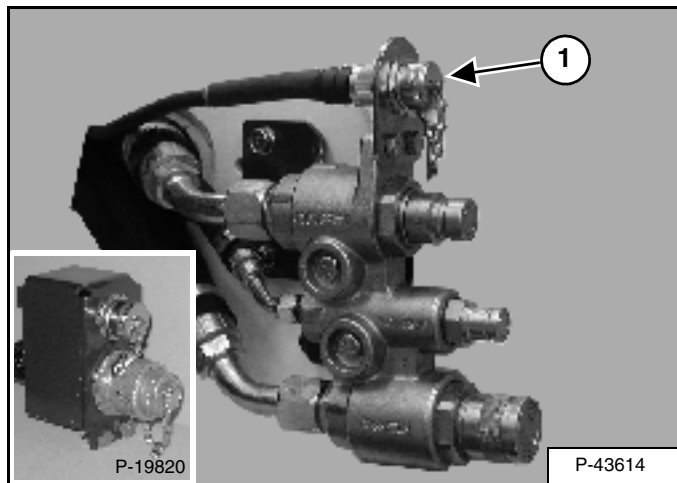

You will need the Dual-Connector (7-pin / 14-pin) kit (1) [Figure 47] to operate early model attachments. See your Bobcat Loader dealer.

### Secondary Front Auxiliary Hydraulics (If Equipped)

Figure 48

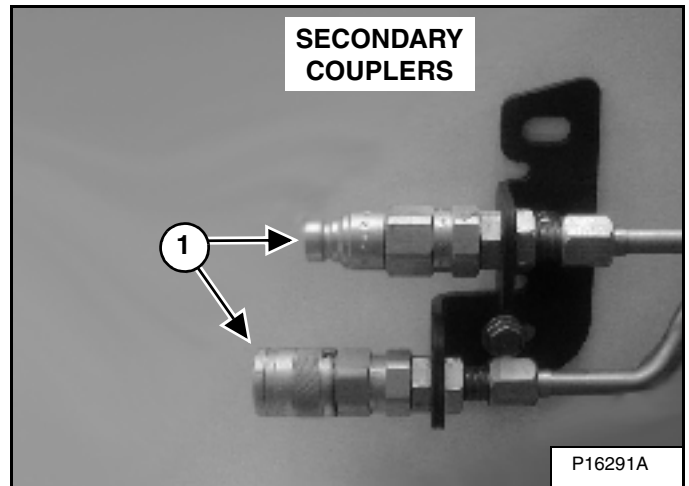

The secondary front auxiliary quick couplers (1) [Figure 48] are available as Field Installed Accessory. These are used when there is a need for additional auxiliary hydraulics (EXAMPLE: Planer side shift).

Connect the attachment to the secondary auxiliary hydraulics (1) [Figure 48].

Set the Auxiliary Hydraulic Button for *Variable Flow* or *Maximum Flow Only*. (See Auxiliary Hydraulics Operation (VARIABLE FLOW) on Page 21) (See also Auxiliary Hydraulics Operation (MAXIMUM FLOW ONLY) on Page 21).

Figure 49

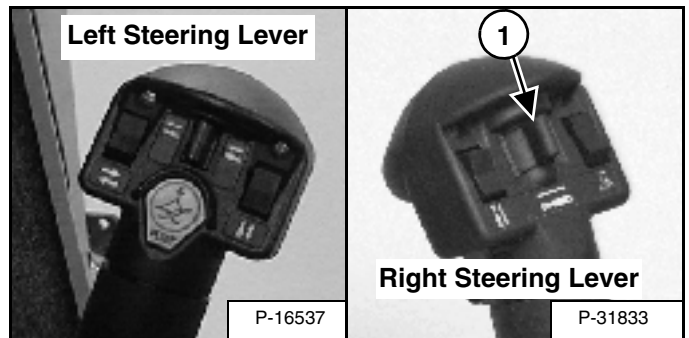

Push switch (1) [Figure 49] to the right or left to change fluid flow direction. (EXAMPLE: Side shift on the Planer.)

**NOTE:** The secondary front auxiliary hydraulics and the rear auxiliary hydraulics operate from the same auxiliary section of the control valve. To operate only one of these auxiliary functions, disconnect the other.



## DAILY INSPECTION (CONT'D)

### Daily Inspection and Maintenance

Maintenance work must be done at regular intervals. Failure to do so will result in excessive wear and early failures. The Service Schedule [Figure 50] is a guide for correct maintenance of the Bobcat Loader. It is located inside the rear door of the loader.

- Engine Oil Level
- Hydraulic / Hydrostatic Fluid Level
- Engine Air Filter, Check Air System for Damage or Leaks
- Engine Coolant Level, Check System for Damage or Leaks
- Operator Cab and Cab Mounting Hardware
- Seat Belt
- Seat Bar and Control Interlocks
- Grease Pivot Pins (Lift Arms, Bob-Tach, Cylinders, Bob-Tach Wedges)
- Tires, Check for Wear, Damage, Correct Air Pressure
- Fuel Filter, Remove Trapped Water
- Loose or Broken Parts, Repair or replace as necessary
- Safety Treads and Safety Signs (Decals), Replace as necessary
- Lift Arm Support Device. Replace if damaged
- Bobcat Interlock Control System (BICS)

## WARNING

**Operator must have instructions before operating the machine. Untrained operators can cause injury or death.**

W-2001-0502

**NOTE: Fluids such as engine oil, hydraulic fluid, coolant, etc. must be disposed of in an environmentally safe manner. Some regulations require that certain spills and leaks on the ground must be cleaned in a specific manner. See local, state and federal regulations for correct disposal.**

## IMPORTANT

### PRESSURE WASHING DECALS

- **Never direct the stream at a low angle toward the decal that could damage the decal causing it to peel from the surface.**
- **Direct the stream at a 90 degree angle and at least 300 mm from the decal. Wash from the center of the decal toward the edges.**

I-2226-0104

## PRE-STARTING PROCEDURE

### Entering The Loader

Figure 51

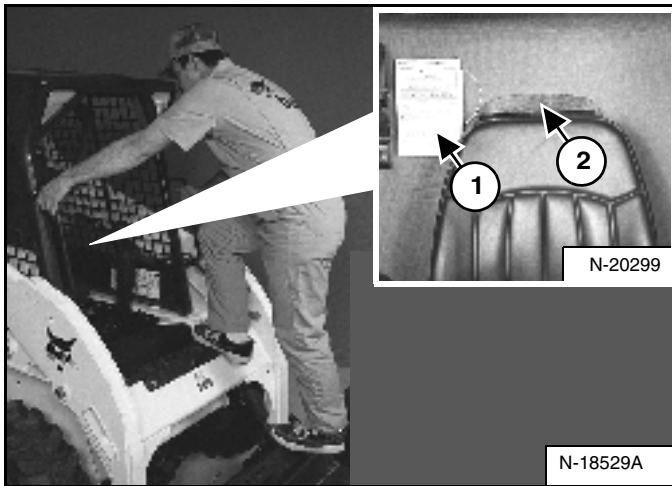

Use the bucket or attachment steps, grab handles and safety treads (on top of the loader lift arms and frame) to get on and off the loader [Figure 51]. Do not jump.

Safety treads are installed on the Bobcat Loader to provide a slip resistant surface for getting on and off the loader.

Keep safety treads clean and replace when damaged. Replacement treads are available from your Bobcat Loader dealer.

Read and understand the Operation & Maintenance Manual and the Operator's Handbook (1) [Figure 51] before operating the loader.

The Operation & Maintenance Manual and other manuals can be kept in a container (2) [Figure 51] provided behind the operator seat.

## WARNING

Instructions are necessary before operating or servicing machine. Read and understand the Operation & Maintenance Manual, Operator's Handbook and signs (decals) on machine. Follow warnings and instructions in the manuals when making repairs, adjustments or servicing. Check for correct function after adjustments, repairs or service. Untrained operators and failure to follow instructions can cause injury or death.

W-2003-0903

## Seat Adjustment

Figure 52

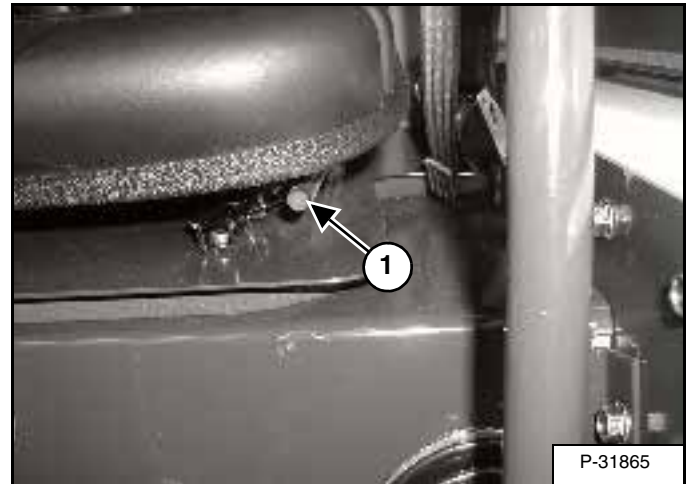

Release the seat lever (1) [Figure 52] and adjust the seat position for comfortable operation of the loader controls.

Figure 53

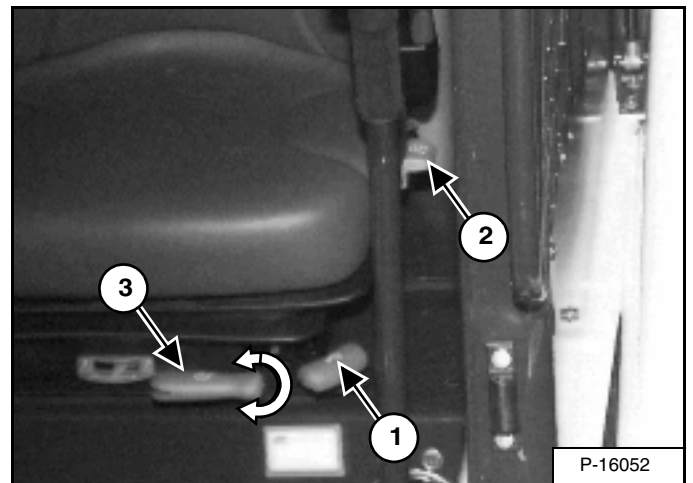

Suspension Seat - (Option) Release the lever (1) [Figure 53] to adjust the seat distance from the steering levers and foot pedals (if equipped).

Release the lever (2) [Figure 53] to adjust the angle of the seat back.

Turn the lever (3) [Figure 53] to adjust the seat cushion for weight of the operator.



## PRE-STARTING PROCEDURE (CONT'D)

### Seat Belt Adjustment

Figure 54

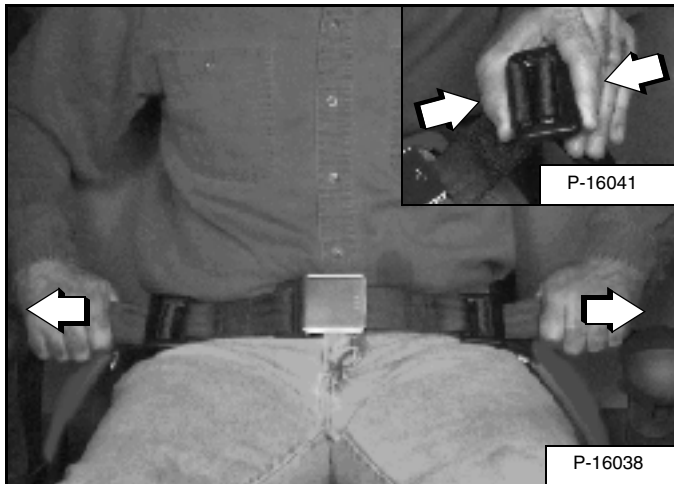

Squeeze both seat belt adjusters to release and lengthen each half of the seat belt [Figure 54].

Fasten the seat belt.

Pull the ends of the belt through the belt adjusters so that the seat belt is snug and the buckle is centered between your hips [Figure 54].

Figure 55

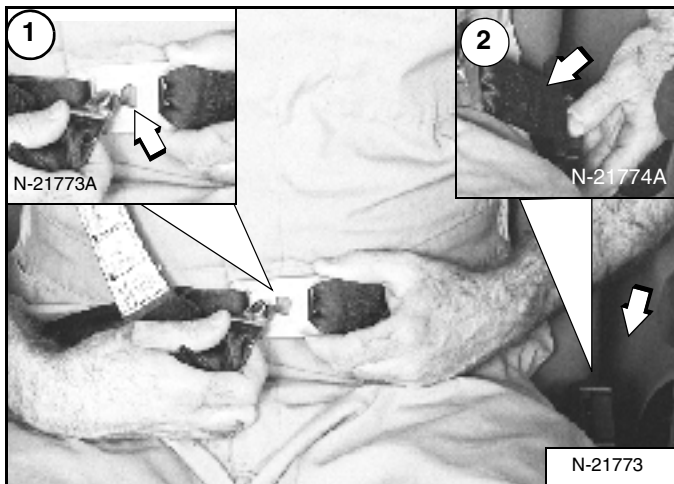

3-Point Restraint - (Option) Connect the shoulder belt to the lap belt (1) [Figure 55]. Pull the lap belt across to the left side of the seat (2) [Figure 55] and fasten.

The shoulder belt must be positioned over your right shoulder and the lap belt must be snug over your lower hips [Figure 55].

# IMPORTANT

Check the seat belt and shoulder belt retractors for correct operation.

Keep retractors clean and replace as necessary.

I-2199-0200

### Seat Bar

Figure 56



Lower the seat bar and engage the parking brake (1) [Figure 56].

Put the foot pedals or hand controls in neutral position.

**NOTE:** Keep your hands on the steering levers and your feet on the foot pedals (or footrests) while operating the loader.

# ! WARNING

## AVOID INJURY OR DEATH

When operating the machine:

- Keep the seat belt fastened snugly.
- The seat bar must be lowered.
- Keep your feet on the pedal controls or footrests and hands on steering levers.

W-2261-0799



## STARTING THE ENGINE

### Key Switch



#### AVOID INJURY OR DEATH

- Engines can have hot parts and hot exhaust gas. Keep flammable material away.
- Do not use machines in atmosphere containing explosive gas.

W-2051-1086

Perform the PRE-STARTING PROCEDURE. (See PRE-STARTING PROCEDURE on Page 27.)

Figure 57



Set the engine speed control to the 1/2 speed position [Figure 57].

Figure 58

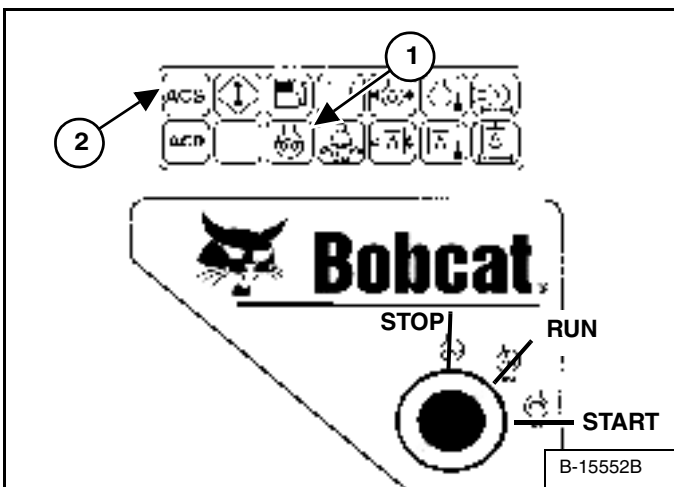

Turn the key switch to RUN [Figure 58]. The indicator lights on the right instrument panel [Figure 58] will come ON briefly and the Instrument Panel / monitoring system will do a self test.

If the temperature is cold, the glow plugs will automatically cycle. The Icon light (1) [Figure 58] will be ON and the cycle time remaining will show in the hourmeter.

When the Icon light goes OFF, turn the key switch to START [Figure 58]. Release the key when the engine starts. It will return to the RUN position.

**NOTE:** Make sure both hand controls (ACS) or Joysticks (SJC) are in the neutral position before starting the engine. Do not move the levers or joysticks from the neutral position when turning the key to RUN or START [Figure 58].

If controls are moved:

- a. The neutral position for the hydraulic valve spool and hand control may not be correctly calibrated. This can result in slight movement of the lift or tilt hydraulic cylinders when the hand control lever is returned to the neutral position after start-up.

OR

- b. ACS indicator light (2) [Figure 58] on right instrument panel will be ON.

If either condition occurs, return key to STOP. Put the controls in neutral position and re-start engine.

## STARTING THE ENGINE (CONT'D)

### Key Switch (Cont'd)

Figure 59

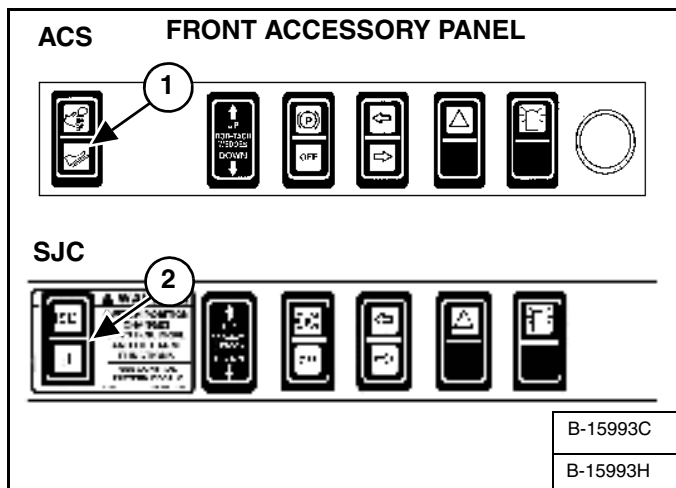

(ACS) Select hand control or foot pedal operation (1) [Figure 59].

OR

(SJC) Select 'ISO' or 'H' Control Pattern (2) [Figure 59].

Figure 60

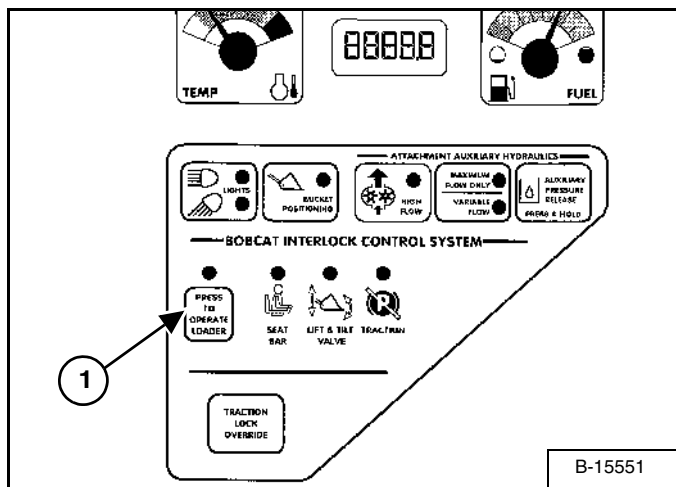

Press the PRESS TO OPERATE LOADER Button (1) [Figure 60] to activate the BICS system and to perform hydraulic and loader functions. (See Cold Temperature Starting on Page 32.)

**NOTE:** (SJC) The pending mode will flash which will indicate PRESS TO OPERATE LOADER is required. The light will flash when key is ON and continue to flash until the PRESS TO OPERATE LOADER button is pressed and thereafter it will light solid. If the mode (ISO / H) is changed while driving, the active mode will be solid and the pending mode will flash. When operation of the machine is returned to neutral, the active mode will then turn off and the pending mode will continue to flash until the PRESS TO OPERATE LOADER button is pressed.



When an engine is running in an enclosed area, fresh air must be added to avoid concentration of exhaust fumes. If the engine is stationary, vent the exhaust outside. Exhaust fumes contain odorless, invisible gases which can kill without warning.

W-2050-1285

## STARTING THE ENGINE (CONT'D)

### Keyless

# ! WARNING

### AVOID INJURY OR DEATH

- Engines can have hot parts and hot exhaust gas. Keep flammable material away.
- Do not use machines in atmosphere containing explosive gas.

W-2051-1086

Perform the PRE-STARTING PROCEDURE. (See PRE-STARTING PROCEDURE on Page 27.)

Figure 61



Set the engine speed control to the 1/2 speed position [Figure 61].

**NOTE:** Loaders with *Keyless Instrument Panel* have a permanent, randomly generated Master Password set at the factory. Your loader will be assigned an Owner Password. Your dealer will provide you with this password. Change the password to one that you will easily remember to prevent unauthorized use of your loader. (See Passwords on Page 112.) Keep your password in a safe place for future needs.

Figure 62

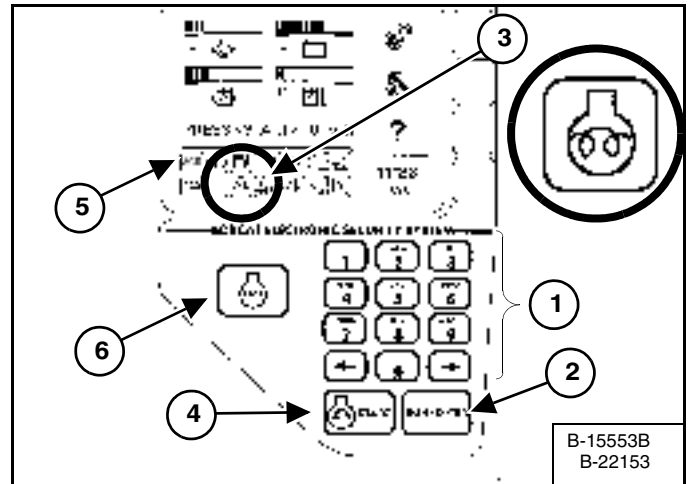

Use the numeric keypad (1) [Figure 62] to enter the password, then press the RUN / ENTER Button (2) [Figure 62].

If the temperature is cold, the glow plugs will automatically cycle and the Icon light (3) [Figure 62] will be ON.

When the Icon light goes OFF, press the START Button (4) [Figure 62]. Release the button when the engine starts.

**NOTE:** Make sure both hand controls (ACS) or Joysticks (SJC) are in the neutral position before starting the engine. Do not move the levers or joysticks from the neutral position when attempting to start the engine.

If either hand control is moved:

a. The neutral position for the hydraulic valve spool and hand control may not be correctly calibrated. This can result in movement of the lift or tilt hydraulic cylinders when the hand control lever is returned to the neutral position after start-up.

OR

b. ACS indicator light (5) [Figure 62] on right instrument panel will be ON.

If either condition occurs, press the STOP button (6) [Figure 62]. Put the controls in neutral position and re-start the engine.

## STARTING THE ENGINE (CONT'D)

### Keyless (Cont'd)

Figure 63

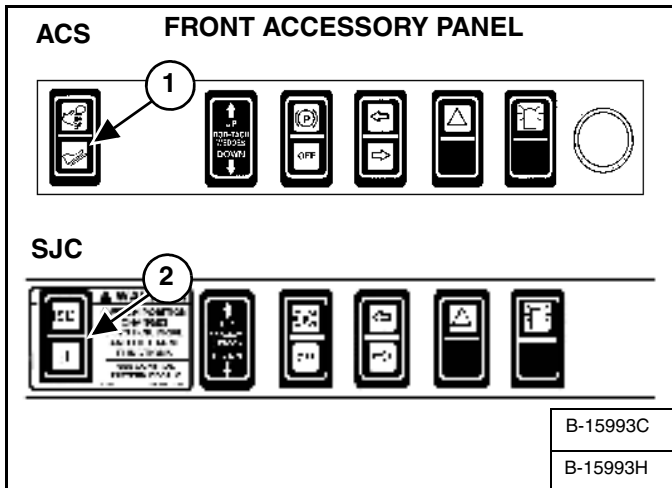

(ACS) Select hand control or foot pedal operation (1) [Figure 63].

OR

(SJC) Select 'ISO' or 'H' Control Pattern (2) [Figure 63].

Figure 64

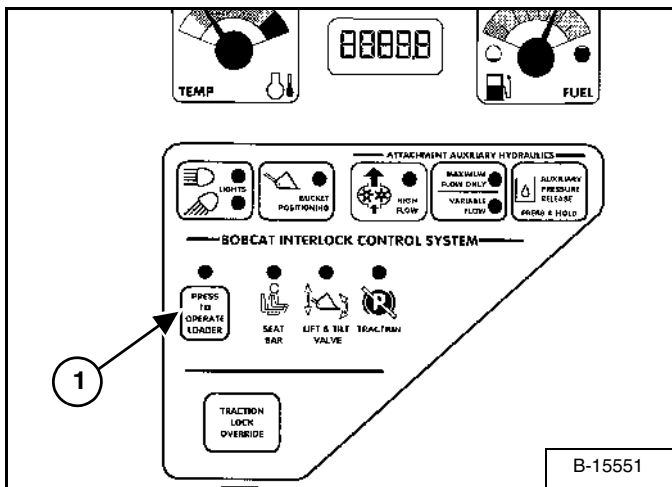

Press the PRESS TO OPERATE LOADER Button (1) [Figure 64] to activate the BICS system and to perform hydraulic and loader functions. (See Cold Temperature Starting on Page 32.)

**NOTE: (SJC)** The pending mode will flash which will indicate PRESS TO OPERATE LOADER is required. The light will flash when key is ON and continue to flash until the PRESS TO OPERATE LOADER button is pressed and thereafter it will light solid. If the mode (ISO / H) is changed while driving, the active mode will be solid and the pending mode will flash. When operation of the machine is returned to neutral, the active mode will then turn off and the pending mode will continue to flash until the PRESS TO OPERATE LOADER button is pressed.

## ! WARNING

When an engine is running in an enclosed area, fresh air must be added to avoid concentration of exhaust fumes. If the engine is stationary, vent the exhaust outside. Exhaust fumes contain odorless, invisible gases which can kill without warning.

W-2050-1285

### Cold Temperature Starting

## ! WARNING

Do not use ether with glow plug (preheat) systems. Explosion can result which can cause injury, death, or severe engine damage.

W-2071-0903

If the temperature is below freezing, perform the following to make starting the engine easier:

- Replace the engine oil with the correct type and viscosity for the anticipated starting temperature.
- Make sure the battery is fully charged.
- Install an engine heater, available from your Bobcat Loader dealer.

**NOTE:** The LCD of the Keyless Panel may not be immediately visible when the temperature is below  $-26^{\circ}\text{C}$  ( $-15^{\circ}\text{F}$ ). It may take 30 seconds to several minutes for the Display Panel to warm up. All systems remain monitored even when the display is off.

## STARTING THE ENGINE (CONT'D)

### Warming The Hydraulic / Hydrostatic System

# IMPORTANT

When the temperature is below  $-30^{\circ}\text{C}$  ( $-20^{\circ}\text{F}$ ), hydrostatic oil must be warmed before starting. The hydrostatic system will not get enough oil at low temperatures and will be damaged. Park the machine in an area where the temperature will be above  $-18^{\circ}\text{C}$  ( $0^{\circ}\text{F}$ ) if possible.

I-2007-1285

Let the engine run for a minimum of 5 minutes to warm the engine and hydrostatic transmission fluid before operating the loader.

Figure 65

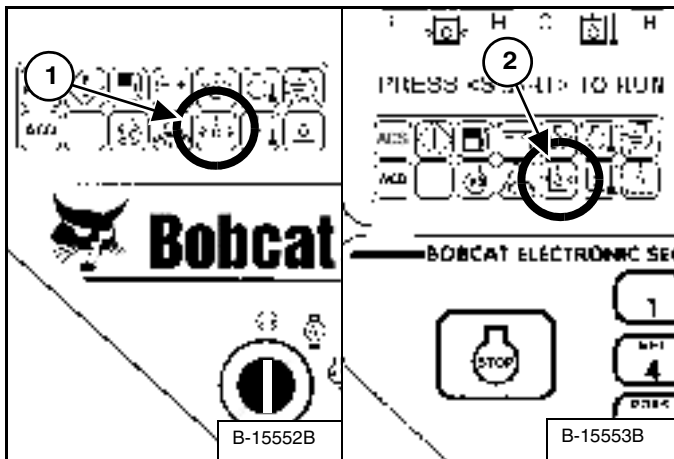

If the Fluid Pressure Icon light (1) [Figure 65] (Key Switch Panel) or (2) [Figure 65] (Keyless Panel) comes ON when operating the loader (cold), more warm up time is needed.

## MONITORING THE DISPLAY PANELS

### Left Panel

Figure 66

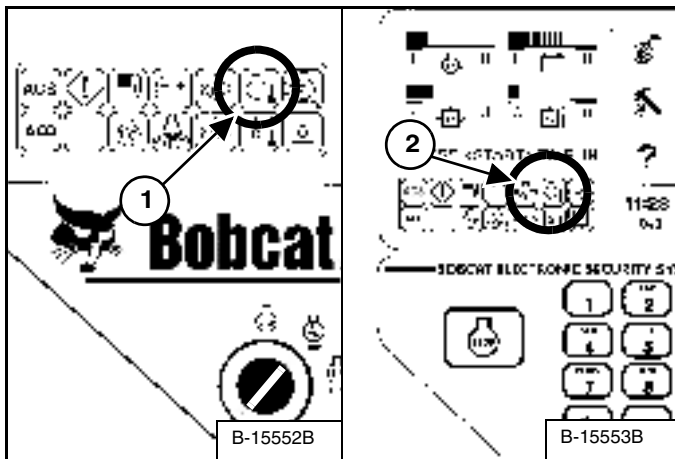

Frequently monitor the temperature and fuel gauges and BICS lights (all must be ON to operate loader) [Figure 66].

### Right Panel (Key Switch)

Figure 67

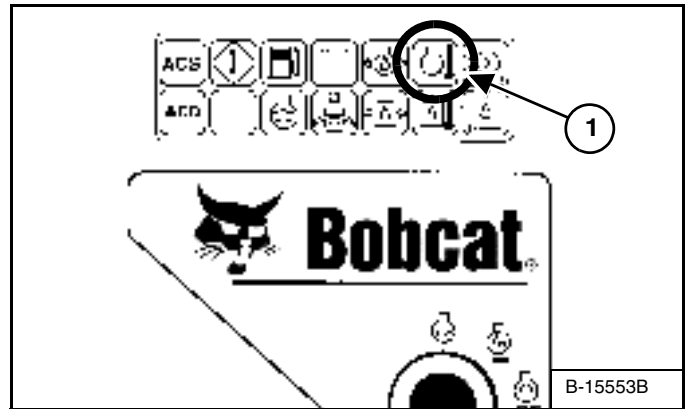

After the engine is running, frequently monitor the right instrument panel [Figure 67] for error conditions.

The associated icon will be ON if there is an error condition.

**EXAMPLE:** Engine Coolant Temperature is High

The Engine Temperature Icon (1) [Figure 67] will be ON.

Press and hold LIGHTS Button for 2 seconds. One of the following SERVICE CODES will be displayed.

- **08-10** Engine Coolant Temperature High
- **08-11** Engine Coolant Temperature Extremely High

Find the cause of the error code and correct before operating the loader again.

## MONITORING THE DISPLAY PANELS (CONT'D)

### Right Panel (Keyless)

Figure 68

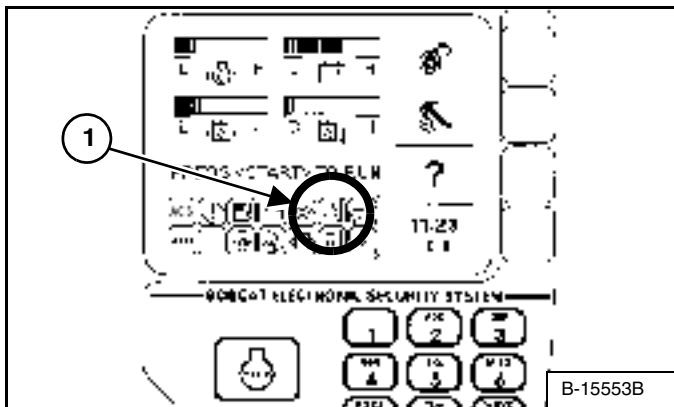

After the engine is running, frequently monitor the right instrument panel [Figure 68] for error conditions.

The associated icon will be ON if there is an error condition.

**EXAMPLE:** Engine Coolant Temperature is High

The Engine Temperature Icon (1) [Figure 68] will be ON.

Press and hold LIGHTS Button for 2 seconds. One of the following SERVICE CODES will be displayed.

- **08-10** Engine Coolant Temperature High
- **08-11** Engine Coolant Temperature Extremely High

In addition, the Keyless Panel display screen will describe the extreme condition that can cause damage to the engine or loader systems [Figure 68].

Find the cause of the error code and correct before operating the loader again.

## Warning And Shutdown

When a WARNING condition exists, the associated Icon light will come ON and there will be 3 beeps from the alarm. Be aware that, if this condition is allowed to continue, there may be damage to the engine or loader hydraulic systems.

When a SHUTDOWN condition exists, the associated Icon light will come ON and there will be a continuous beep from the alarm and the monitoring system will automatically stop the engine in 10 seconds. The engine can be restarted to move or relocate the loader.

The SHUTDOWN feature is associated with the following Icons:

- **General Warning**
- **Engine Oil Pressure**
- **Engine Coolant Temperature**
- **Hydraulic Oil Temperature**
- **Hydrostatic Charge Pressure**

Whenever **STOP** appears on the display screen, lower the lift arms all the way, put the attachment flat on the ground and stop the engine to prevent damage to the engine or loader systems.

## STOPPING THE ENGINE AND LEAVING THE LOADER

### Procedure

Figure 69



Stop the Bobcat Loader on level ground.

Lower the lift arms fully and put the attachment flat on the ground [Figure 69].

Figure 70



Pull the engine speed control fully backward [Figure 70] to decrease the engine speed.

Figure 71

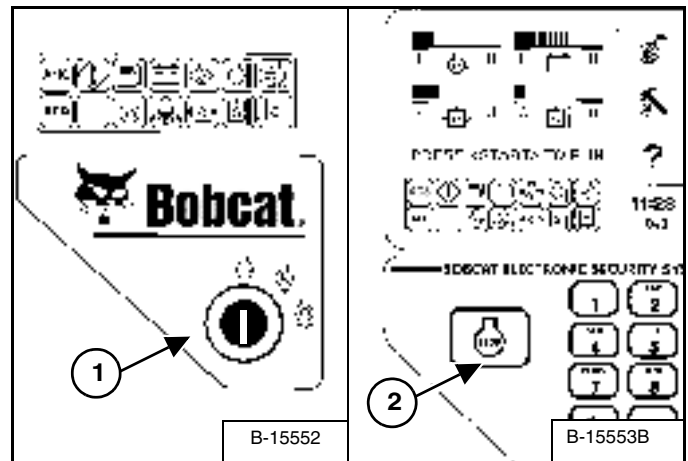

Engage the parking brake.

Turn the key switch to the STOP position (1) [Figure 71] (*Key Switch*) or press the STOP Button (2) [Figure 71] (*Keyless*).

Lift the seat bar and make sure the lift and tilt functions are deactivated.

Unbuckle the seat belt.

Remove the key from the switch (*Key Switch*) to prevent operation of the loader by unauthorized personnel.

Exit the loader using grab handles, safety tread and steps (maintaining a 3-point contact) [Figure 69].

## WARNING

**Before you leave the operator's seat:**

- Lower the lift arms, put the attachment flat on the ground.
- Stop the engine.
- Engage the parking brake.
- Raise seat bar.
- (Foot Pedal Controls) Move pedals until both lock.
- (Advanced Control system - ACS) Move the hydraulic controls to the NEUTRAL POSITION to make sure that both lift and tilt functions are deactivated.  
The seat bar system must deactivate the lift and tilt control functions when the seat bar is up. Service the system if hand controls do not deactivate.
- (Selectable Joystick Controls - SJC) Move the joysticks to the NEUTRAL POSITION to make sure that travel and hydraulic functions are deactivated.  
The seat bar system must deactivate these functions when the seat bar is up. Service the system if controls do not deactivate.

W-2463-0603



**STOPPING THE ENGINE AND LEAVING THE LOADER (CONT'D)**

**Emergency Exit**

The front opening on the operator cab and rear window provide exits.

*Rear Window (If Equipped)*

**Figure 72**



Pull on the tag on the top of the rear window to remove the rubber cord [Figure 72].

Push the rear window out of the rear of the operator cab.

**Figure 73**



Exit through the rear of the operator cab [Figure 73].

*Front Door (If Equipped)*

**NOTE:** When an Operator Cab Enclosure Kit is installed, the window of the front door can be used as an emergency exit [Figure 74].

**NOTE:** If the loader has a Special Application Door Kit installed, the window of the front door is NOT an emergency exit.

**Figure 74**

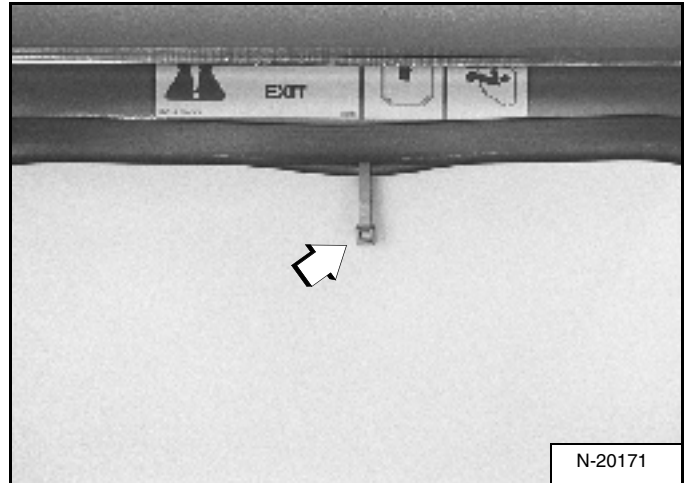

Pull the plastic loop at the top of the window in the front door to remove the rubber cord [Figure 74].

**Figure 75**

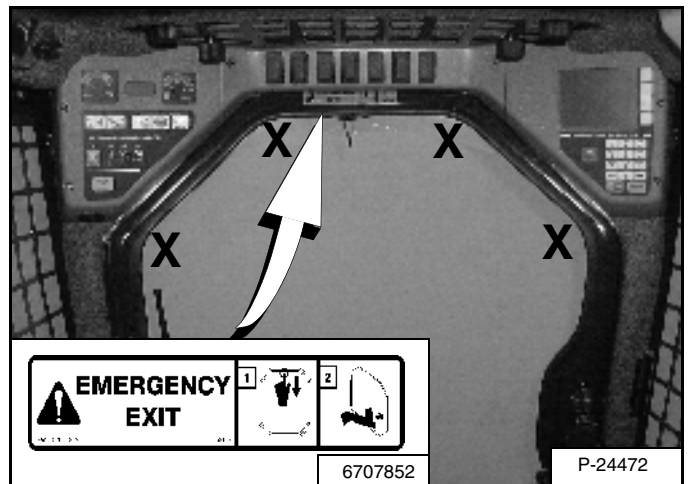

Push the window out with your foot [Figure 75] at any corner of the window.

Exit through the front door.

## ATTACHMENTS

### Choosing The Correct Bucket

# ! WARNING

Never use attachments or buckets which are not approved by Bobcat Company. Buckets and attachments for safe loads of specified densities are approved for each model. Unapproved attachments can cause injury or death.

W-2052-0500

**NOTE: Warranty is void if non-approved attachments are used on the Bobcat Loader.**

The dealer can identify, for each model loader, the attachments and buckets approved by Bobcat. The buckets and attachments are approved for Rated Operating Capacity and for secure fastening to the Bob-Tach.

The Rated Operating Capacity for this loader is shown on a decal in the operator cab. (See Fluid Capacities on Page 122.)

The Rated Operating Capacity is determined by using a standard dirt bucket, and material of normal density, such as dirt or dry gravel. If longer buckets are used, the load center moves forward and reduces the ROC. If very dense material is loaded, the volume must be reduced to prevent overloading.

Figure 76

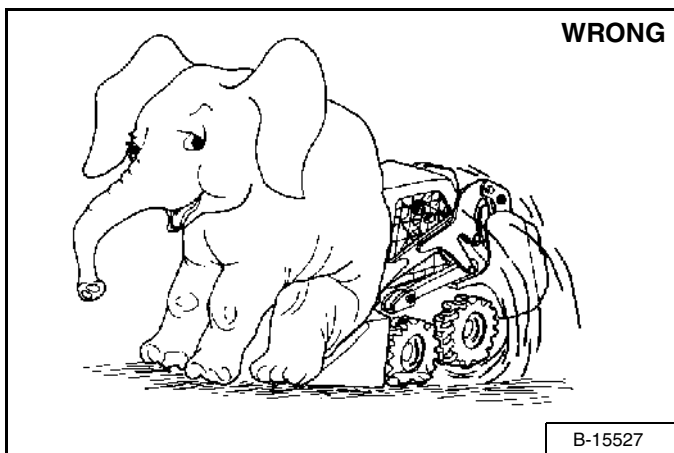

Exceeding the Rated Operating Capacity [Figure 76] can cause the following problems:

- Steering the loader may be difficult.
- Tracks will wear faster.
- There will be a loss of stability.
- The life of the Bobcat Loader will be reduced.

Use the correct size bucket for the type and density of material being handled. For safe handling of materials and avoiding machine damage, the attachment (or bucket) should handle a full load without going over the Rated Operating Capacity for the loader. Partial loads make steering more difficult.

### Pallet Forks

Figure 77

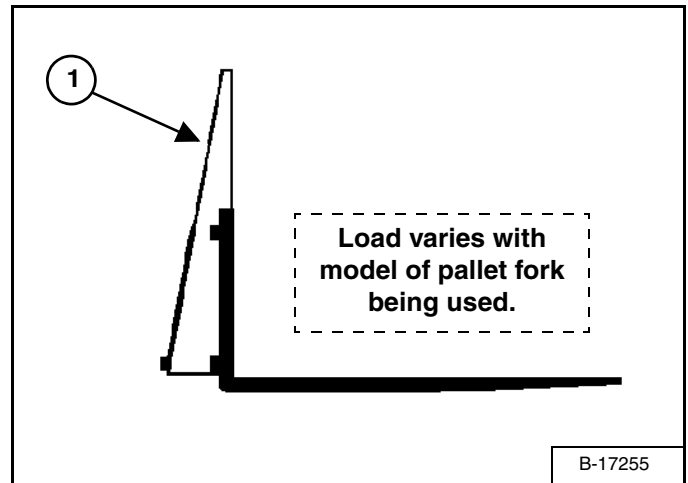

The maximum load to be carried when using a pallet fork is shown on a decal located on the pallet fork frame (1) [Figure 77].

See your Bobcat dealer for more information about pallet fork inspection, maintenance and replacement. See your Bobcat Loader dealer for Rated Operating Capacity when using a pallet fork and for other available attachments.

# ! WARNING

**AVOID INJURY OR DEATH**  
Do not exceed Rated Operating Capacity. Excessive load can cause tipping or loss of control.

W-2053-0903

## ATTACHMENTS (CONT'D)

### Installing And Removing The Attachment (Hand Lever Bob-Tach)

The Bob-Tach is used for fast changing of buckets and attachments. See the appropriate Attachment Operation & Maintenance Manual to install other attachments.

Figure 78

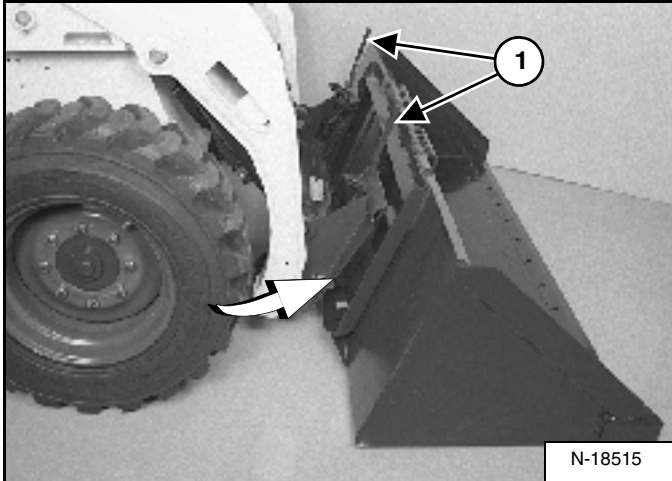

#### Installing

Pull the Bob-Tach levers all the way up (1) [Figure 78].

Enter the loader and perform the PRE-STARTING PROCEDURE. (See PRE-STARTING PROCEDURE on Page 27.)

Lower the lift arms and tilt the Bob-Tach forward.

Drive the loader forward until the top edge of the Bob-Tach is completely under the top flange of the bucket [Figure 78] (or other attachment). Be sure the Bob-Tach levers do not hit the bucket.

Figure 79

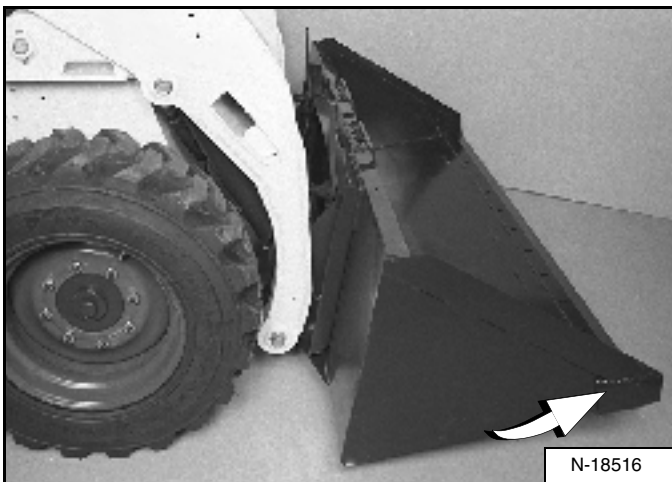

Tilt the Bob-Tach backward until the cutting edge of the bucket (or other attachment) is slightly off the ground [Figure 79].

Stop the engine and exit the loader.

## WARNING

Before you leave the operator's seat:

- Lower the lift arms, put the attachment flat on the ground.
- Stop the engine.
- Engage the parking brake.
- Raise seat bar.
- (Foot Pedal Controls) Move pedals until both lock.
- (Advanced Control system - ACS) Move the hydraulic controls to the NEUTRAL POSITION to make sure that both lift and tilt functions are deactivated.  
The seat bar system must deactivate the lift and tilt control functions when the seat bar is up. Service the system if hand controls do not deactivate.
- (Selectable Joystick Controls - SJC) Move the joysticks to the NEUTRAL POSITION to make sure that travel and hydraulic functions are deactivated.  
The seat bar system must deactivate these functions when the seat bar is up. Service the system if controls do not deactivate.

W-2463-0603

Figure 80

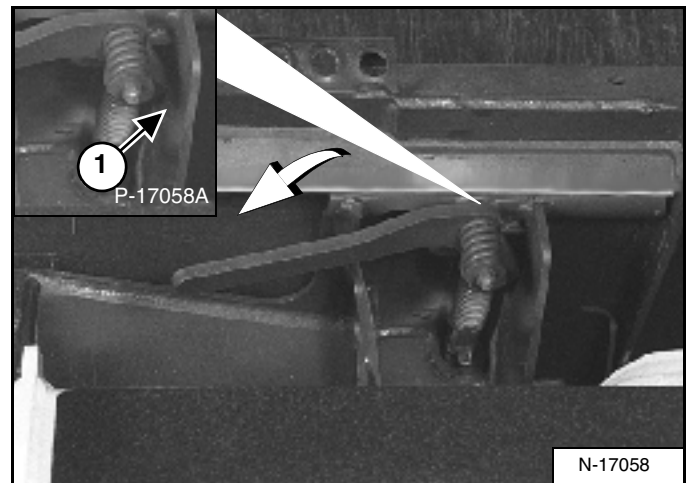

Push down on the Bob-Tach levers until they are fully engaged in the locked position (1) [Figure 80] (wedges fully extended).

## ATTACHMENTS (CONT'D)

### Installing And Removing The Attachment (Hand Lever Bob-Tach) (Cont'd)

*Installing (Cont'd)*

Figure 81

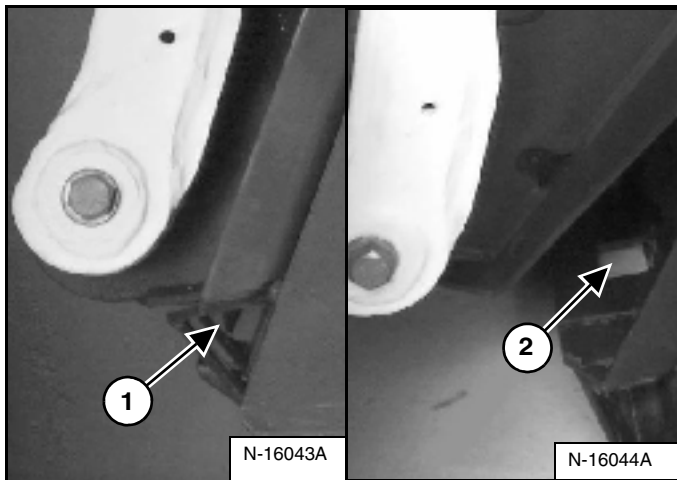

The wedges (1) [Figure 81] must extend through the holes (2) [Figure 81] in the mounting frame of the bucket (or attachment), securely fastening the bucket to the Bob-Tach.

## ! WARNING

Bob-Tach wedges must extend through the holes in attachment. Levers must be fully down and locked. Failure to secure wedges can allow attachment to come off and cause injury or death.

W-2102-0588

### *Removing*

Lower the lift arms and put the attachment flat on the ground and lower or close the hydraulic equipment.

- If the attachment is hydraulically controlled (combination bucket, backhoe, etc.), stop the engine and relieve hydraulic pressure at the quick couplers. (See Relieve Hydraulic Pressure (Loader and Attachment) on Page 23.)

Raise the seat bar, unfasten the seat belt, set the parking brake and exit the loader.

## ! WARNING

Before you leave the operator's seat:

- Lower the lift arms, put the attachment flat on the ground.
- Stop the engine.
- Engage the parking brake.
- Raise seat bar.
- (Foot Pedal Controls) Move pedals until both lock.
- (Advanced Control system - ACS) Move the hydraulic controls to the NEUTRAL POSITION to make sure that both lift and tilt functions are deactivated.
- (Selectable Joystick Controls - SJC) Move the joysticks to the NEUTRAL POSITION to make sure that travel and hydraulic functions are deactivated.

The seat bar system must deactivate the lift and tilt control functions when the seat bar is up. Service the system if hand controls do not deactivate.

The seat bar system must deactivate these functions when the seat bar is up. Service the system if controls do not deactivate.

W-2463-0603

Figure 82

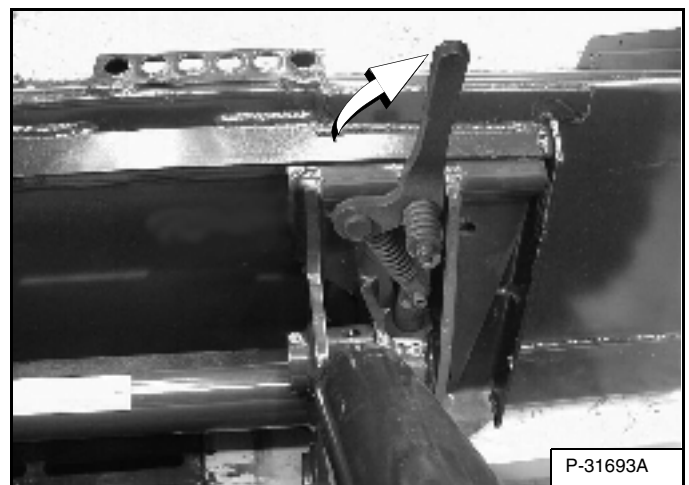

Pull the Bob-Tach levers [Figure 82] all the way up.

## ! WARNING

Bob-Tach levers have spring tension. Hold lever tightly and release slowly. Failure to obey warning can cause injury.

W-2054-1285

## ATTACHMENTS (CONT'D)

### Installing And Removing The Attachment (Hand Lever Bob-Tach) (Cont'd)

#### Removing (Cont'd)

Enter the loader.

Perform the PRE-STARTING PROCEDURE on Page 27.

Start the engine.

Release the parking brake.

Be sure the lift arms are all the way down. Tilt the Bob-Tach forward.

**Figure 83**

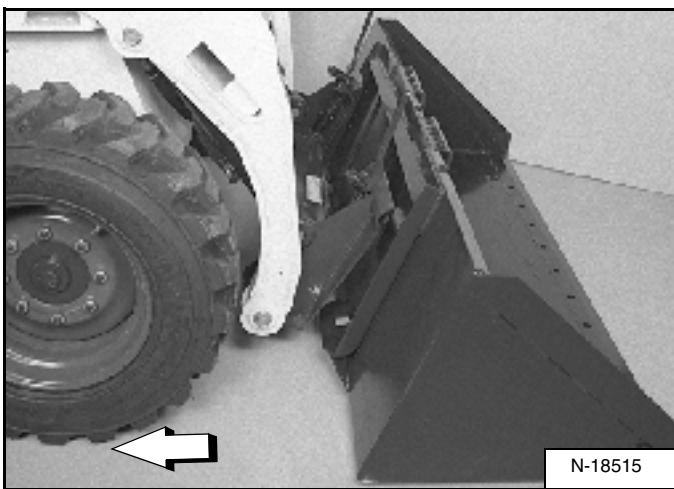

Move the loader backward, away from the bucket or attachment [Figure 83].

### Installing And Removing The Attachment (Power Bob-Tach Option)

#### Installing

The Bob-Tach is used for fast changing of buckets and attachments. See the appropriate Attachment Operation & Maintenance Manual to install other attachments.

Perform the PRE-STARTING PROCEDURE. (See PRE-STARTING PROCEDURE on Page 27.)

Lower the lift arms and tilt the Bob-Tach forward.

**Figure 84**

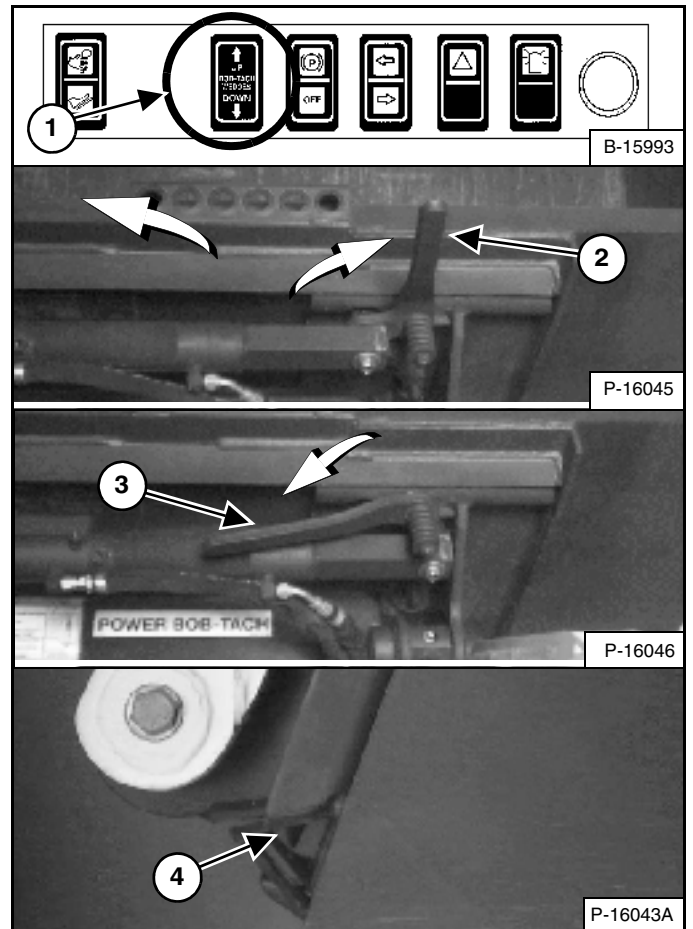

Push and hold BOB-TACH “WEDGES UP” switch (Front Accessory Panel) (1) [Figure 84] until levers are in unlocked position (2) [Figure 84] (wedges fully raised).

## ATTACHMENTS (CONT'D)

### Installing And Removing The Attachment (Power Bob-Tach Option) (Cont'd)

*Installing (Cont'd)*

**Figure 85**

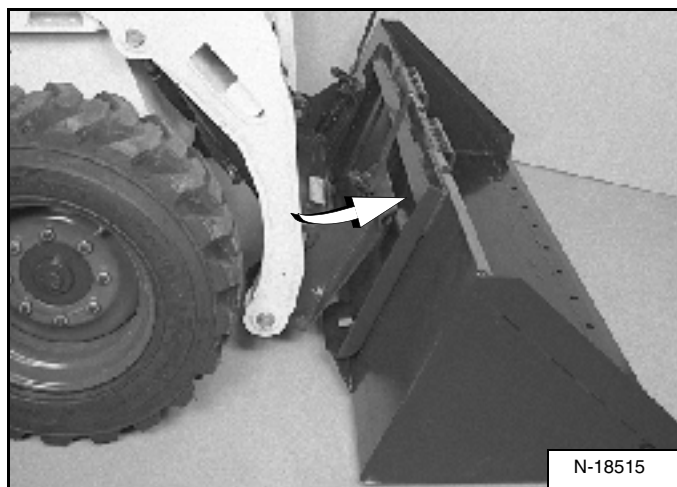

Drive the loader forward until the top edge of the Bob-Tach is completely under the top flange of the bucket [Figure 85] (or other attachment).

**Figure 86**

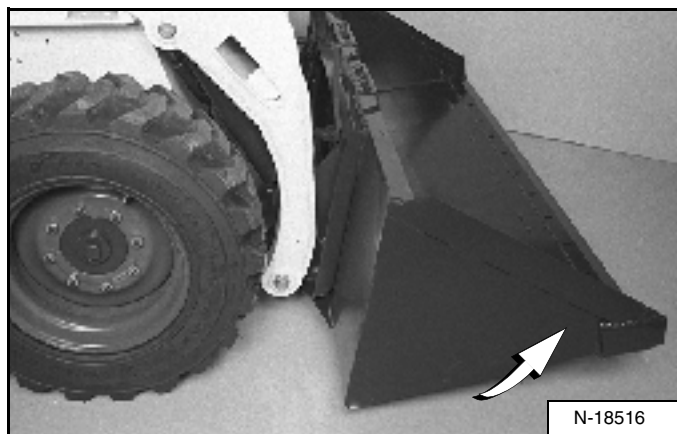

Tilt the Bob-Tach backward until the cutting edge of the bucket (or other attachment) is slightly off the ground [Figure 86].

Push and hold BOB-TACH "WEDGES DOWN" switch (Front Accessory Panel) (1) [Figure 84] until levers are fully engaged in the locked position (3) [Figure 84] (wedges fully extended).

The wedges (4) [Figure 84] must extend through the holes in the mounting frame of the bucket (or attachment), securely fastening the bucket to the Bob-Tach.

## **WARNING**

Bob-Tach wedges must extend through the holes in attachment. Levers must be fully down and locked. Failure to secure wedges can allow attachment to come off and cause injury or death.

W-2102-0588

**NOTE:** The Power Bob-Tach system has continuous pressurized hydraulic oil to keep the wedges in the engaged position and prevent attachment disengagement. Because the wedges can slowly lower, the operator may need to reactivate the switch (WEDGES UP) before installing an attachment to be sure both wedges are fully raised before installing the attachment.

## ATTACHMENTS (CONT'D)

### Installing And Removing The Attachment (Power Bob-Tach Option) (Cont'd)

#### Removing

Lower the lift arms and put the attachment flat on the ground and lower or close the hydraulic equipment.

- If the attachment is hydraulically controlled (combination bucket, backhoe, etc.):

Stop the engine and relieve hydraulic pressure in the auxiliary circuit. (See Relieve Hydraulic Pressure (Loader and Attachment) on Page 23.)

Exit the loader and disconnect the hydraulic hoses from the attachment.

Enter the loader.

Perform the PRE-STARTING PROCEDURE. (See PRE-STARTING PROCEDURE on Page 27.)

Start the engine.

Release the parking brake.

Figure 87

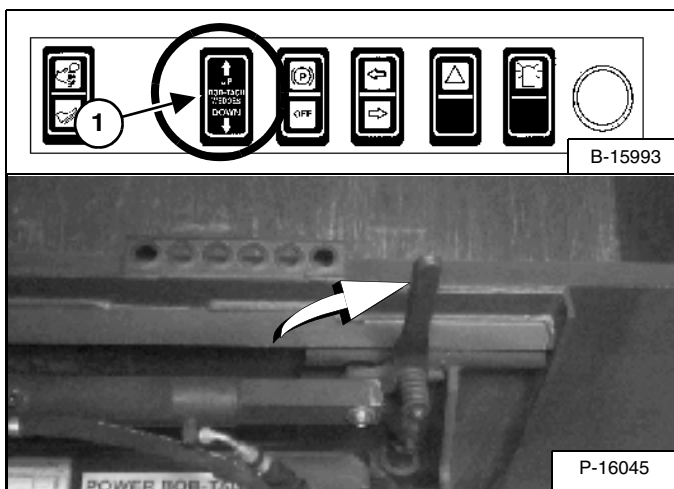

Push and hold the BOB-TACH "WEDGES UP" Switch (Front Accessory Panel) (1) [Figure 87] until the wedges are fully raised.

Tilt the Bob-Tach forward.

Figure 88

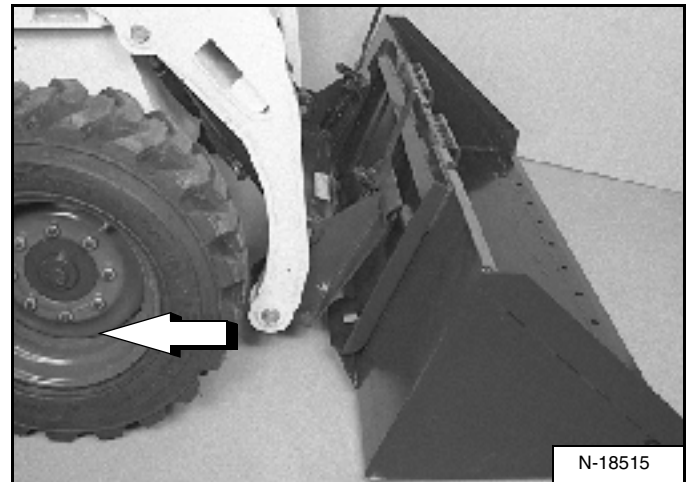

Move the loader backward, away from the bucket or attachment [Figure 88].

**NOTE:** The Power Bob-Tach system has continuous pressurized hydraulic oil to keep the wedges in the engaged position and prevent attachment disengagement. Because the wedges can slowly lower, the operator may need to reactivate the switch (WEDGES UP) before installing an attachment to be sure both wedges are fully raised before installing the attachment.

## OPERATING PROCEDURE

### Inspect The Work Area

Before beginning operation, inspect the work area for unsafe conditions.

Look for sharp drop-offs or rough terrain. Have underground utility lines (gas, water, sewer, irrigation, etc.) located and marked.

Remove objects or other construction material that could damage the loader or cause personal injury.

### Operating With A Full Bucket

When operating on a public road or highway, always follow local regulations. For example: Slow Moving Vehicle Sign or direction signals may be required.

Always warm the engine and hydrostatic system before operating the loader.

## IMPORTANT

**Machines warmed up with moderate engine speed and light load have longer life.**

I-2015-0284

Operate the loader with the engine at full speed for maximum horsepower. Move the steering levers only a small amount to operate the loader slowly.

New operators must operate the loader in an open area without bystanders. Operate the controls until the loader can be handled at an efficient and safe rate for all conditions of the work area.

Figure 89

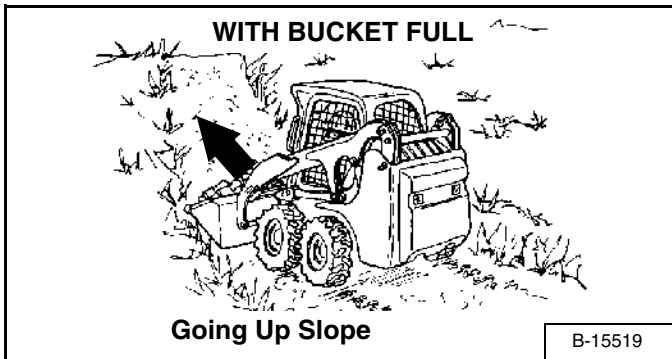

## ! WARNING

### AVOID INJURY OR DEATH

- Keep the lift arms as low as possible.
- Do not travel or turn with the lift arms up.
- Turn on level ground.
- Go up and down slopes, not across them.
- Keep the heavy end of the machine uphill.
- Do not overload the machine.

Failure to obey warnings can cause the machine to tip or roll over and cause injury or death.

W-2018-1187

Figure 90

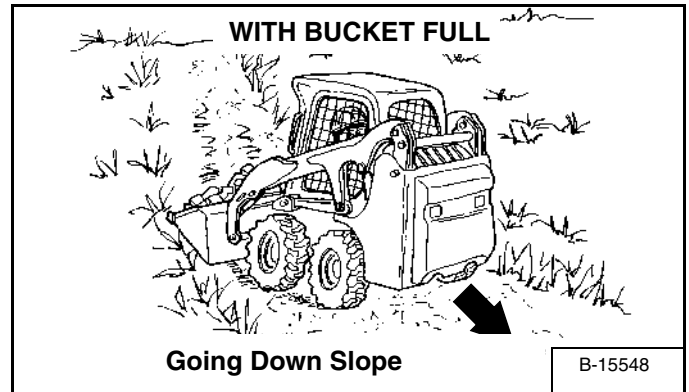

With a full bucket, go up or down the slope with the heavy end toward the top of the slope [Figure 89] and [Figure 90].



## OPERATING PROCEDURE (CONT'D)

### Operating With An Empty Bucket

Figure 91

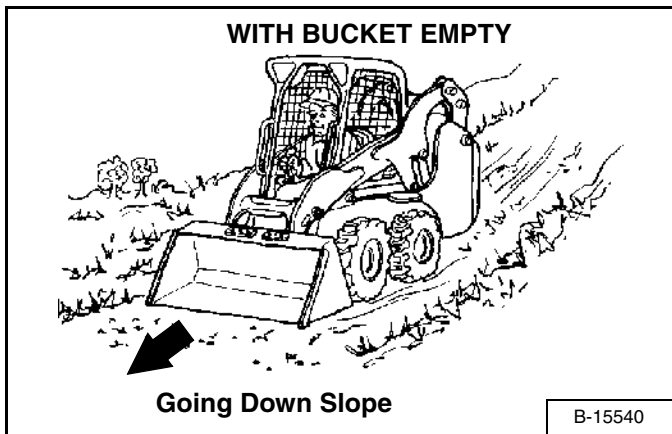
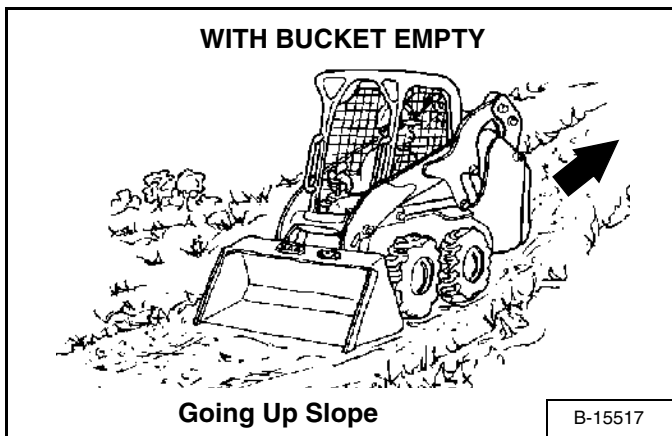

Figure 92



With empty bucket, go down or up the slope with the heavy end toward the top of the slope [Figure 91] and [Figure 92].

## OPERATING PROCEDURE (CONT'D)

### Filling And Emptying The Bucket (Foot Pedals)

#### Filling

Figure 93

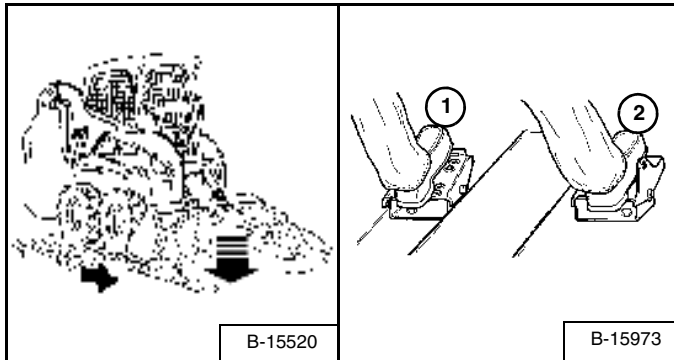
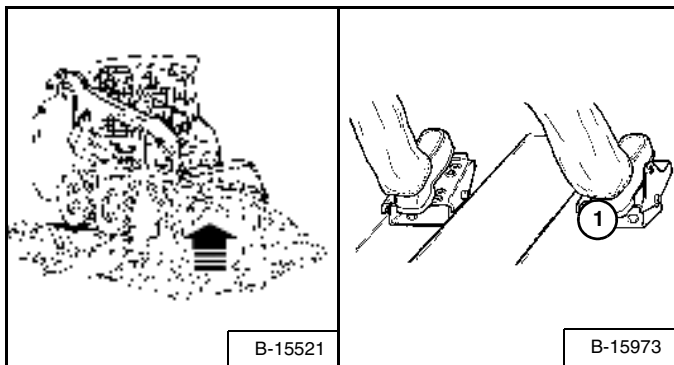

Figure 94



Lower the lift arms all the way (1) [Figure 93].

Tilt the bucket forward (2) [Figure 93] until the cutting edge of the bucket is on the ground.

Drive slowly forward into the material. Tilt the bucket backward (1) [Figure 94] all the way when the bucket is full.

Drive backward away from the material.

## WARNING

Load, unload and turn on flat level ground. Do not exceed Rated Operating Capacity shown on sign (decal) in cab. Failure to obey warnings can cause the machine to tip or roll over and cause injury or death.

W-2056-0903

#### Emptying

Figure 95

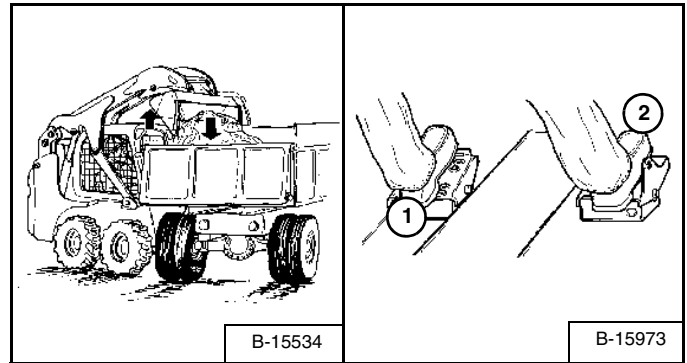

Keep the bucket low when moving to the area where you want to empty the bucket.

Raise the lift arms (1) [Figure 95]. Level the bucket (2) [Figure 95] while raising the lift arms to help prevent material from falling off the back of the bucket.

Drive forward slowly until the bucket is over the top of the truck box or bin.

Empty the bucket (2) [Figure 95]. If all the material is near the side of the truck or bin, use the bucket tilt to move it to the other side.

## WARNING

Never dump over an obstruction, such as a post, that can enter the operator cab. The machine could tip forward and cause injury or death.

W-2057-0694

## OPERATING PROCEDURE (CONT'D)

### Leveling The Ground Using Float (Foot Pedals)

Figure 96

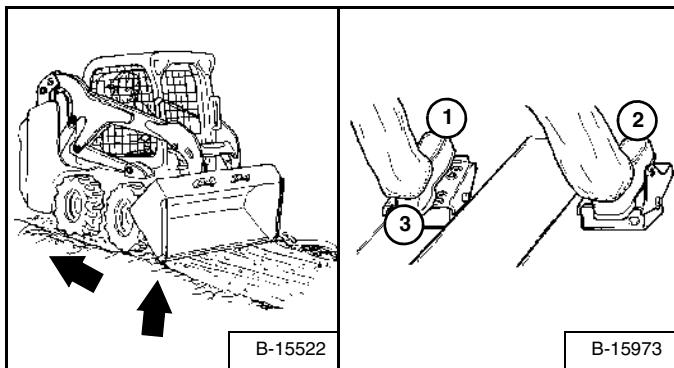

Put the lift arms in *float* position by pushing the pedal all the way forward (1) [Figure 96] until the pedal is locked in the forward position.

Tilt the bucket forward (2) [Figure 96] to change the position of the cutting edge of the bucket.

With the bucket tilted farther forward, there is more force on the cutting edge and more loose material can be moved.

Drive backward to level loose material.

Push the bottom of the lift pedal (3) [Figure 96] to unlock the float position.

# IMPORTANT

Never drive forward when the hydraulic control for lift arms is in float position.

I-2005-1285

## OPERATING PROCEDURE (CONT'D)

### Digging And Filling A Hole (Foot Pedals)

#### Digging

Figure 97

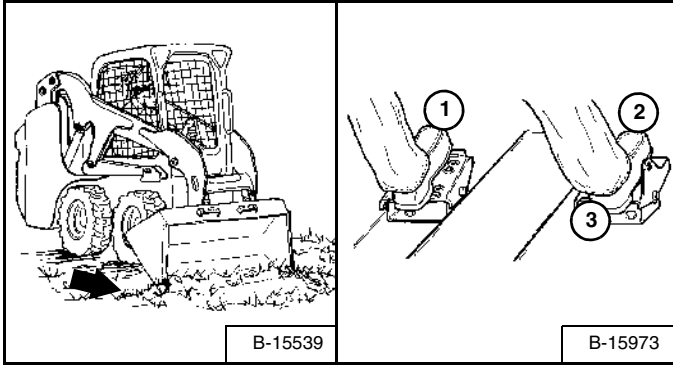

Lower the lift arms all the way (1) [Figure 97]. Put the cutting edge of the bucket on the ground (2) [Figure 97].

Drive forward slowly and continue to tilt the bucket down (2) [Figure 97] until it enters the ground.

Raise the cutting edge a small amount (3) [Figure 97] to increase traction and keep an even digging depth. Continue to drive forward until the bucket is full. When the ground is hard, raise and lower the cutting edge of the bucket (2 and 3) [Figure 97] while driving forward slowly.

Figure 98

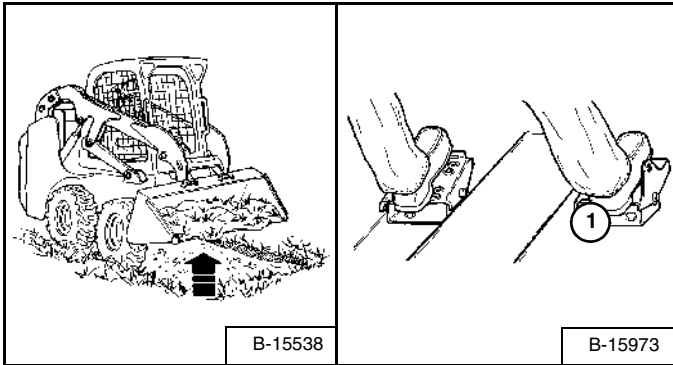

Tilt the bucket backward (1) [Figure 98] as far as it will go when the bucket is full.

#### Filling

Figure 99

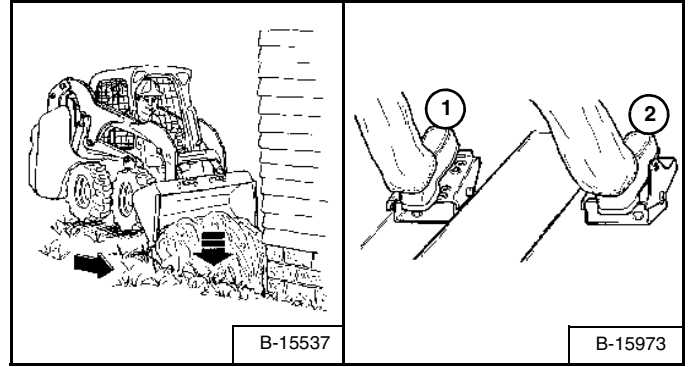

Lower the lift arms (1) [Figure 99] and put the cutting edge of the bucket on the ground (2) [Figure 99]. Drive forward to the edge of the hole to push the material into the hole.

Tilt the bucket forward (2) [Figure 99] as soon as it is past the edge of the hole.

If necessary, raise the lift arms to empty the bucket.

## OPERATING PROCEDURE (CONT'D)

### Filling And Emptying The Bucket (ACS - Handles, SJC - 'H' Pattern)

#### Filling

Figure 100

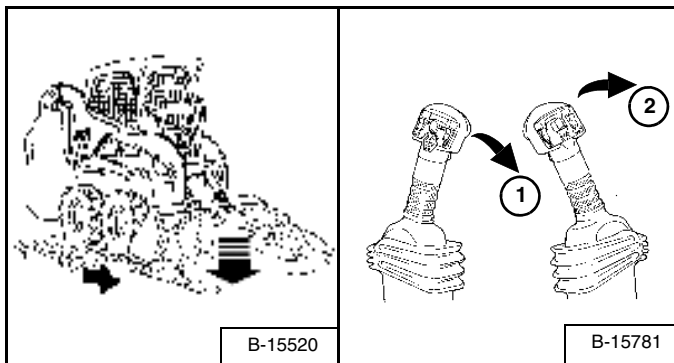
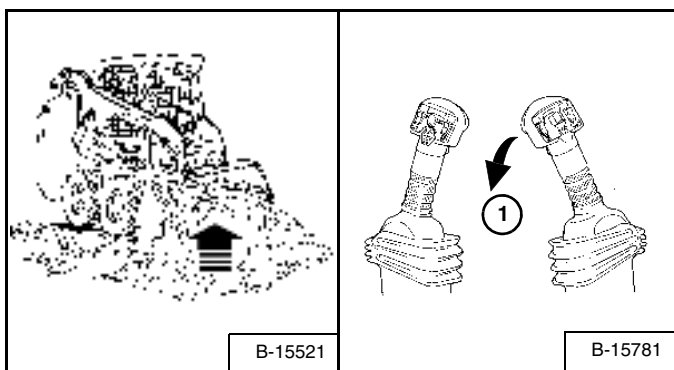

Figure 101



Lower the lift arms all the way (1) [Figure 100].

Tilt the bucket forward (2) [Figure 100] until the cutting edge of the bucket is on the ground.

Drive slowly forward into the material. Tilt the bucket backward (1) [Figure 101] all the way when the bucket is full.

Drive backward away from the material.

## ! WARNING

Load, unload and turn on flat level ground. Do not exceed Rated Operating Capacity shown on sign (decal) in cab. Failure to obey warnings can cause the machine to tip or roll over and cause injury or death.

W-2056-0903

#### Emptying

Figure 102

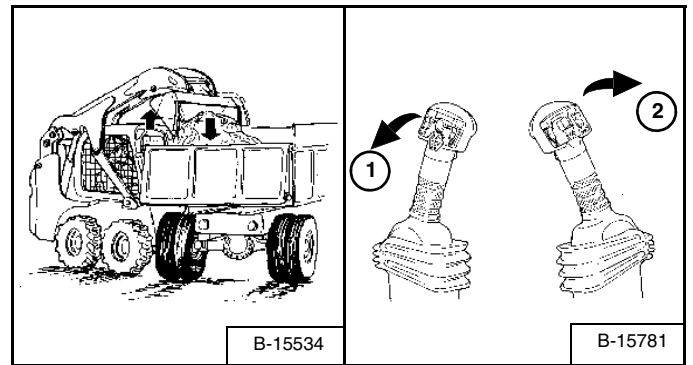

Keep the bucket low when moving to the area where you want to empty the bucket.

Raise the lift arms (1) [Figure 102]. Level the bucket (2) [Figure 102] while raising the lift arms to help prevent material from falling off the back of the bucket.

Drive forward slowly until the bucket is over the top of the truck box or bin.

Empty the bucket (2) [Figure 102]. If all material is near the side of the truck or bin, use the bucket tilt to move it to the other side.

## ! WARNING

Never dump over an obstruction, such as a post, that can enter the operator cab. The machine could tip forward and cause injury or death.

W-2057-0694

## OPERATING PROCEDURE (CONT'D)

### Leveling The Ground Using Float (ACS - Handles, SJC - 'H' Pattern)

Figure 103

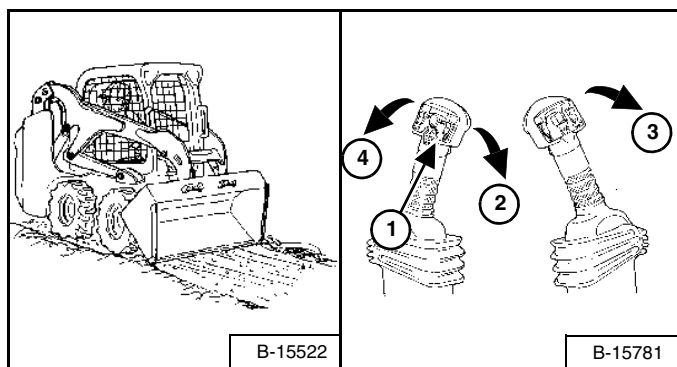

Press and hold the float button (1) [Figure 103] while the lever is in neutral. While lowering the lift arms (2) [Figure 103], release the float button.

Tilt the bucket forward (3) [Figure 103] to change the position of the cutting edge of the bucket.

With the bucket tilted farther forward, there is more force on the cutting edge and more loose material can be moved.

Drive backward to level loose material.

To disengage float, press the float button (1) again or raise the lift arms (4) [Figure 103].

## IMPORTANT

Never drive forward when the hydraulic control for lift arms is in float position.

I-2005-1285

## OPERATING PROCEDURE (CONT'D)

### Digging And Filling A Hole (ACS - Handles, SJC - 'H' Pattern)

#### Digging

Figure 104

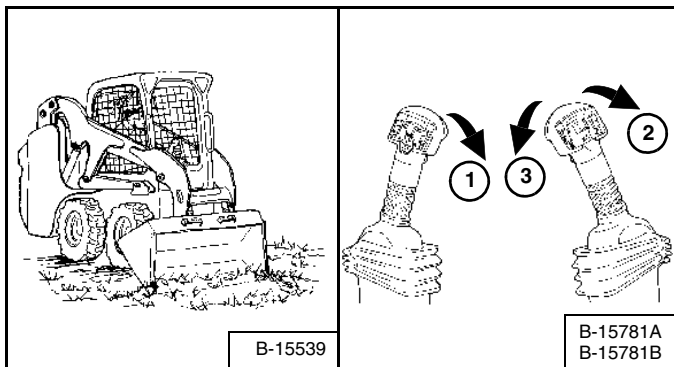

Lower the lift arms all the way (1) [Figure 104]. Tilt the bucket forward (2) [Figure 104] until the cutting edge of the bucket is on the ground.

Drive forward slowly and continue to tilt the bucket down (2) [Figure 104] until it enters the ground.

Tilt the bucket backward a small amount (3) [Figure 104] to increase traction and keep an even digging depth. Continue to drive forward until the bucket is full. When the ground is hard, raise and lower the cutting edge (1 and 2) [Figure 104] while driving forward.

Figure 105

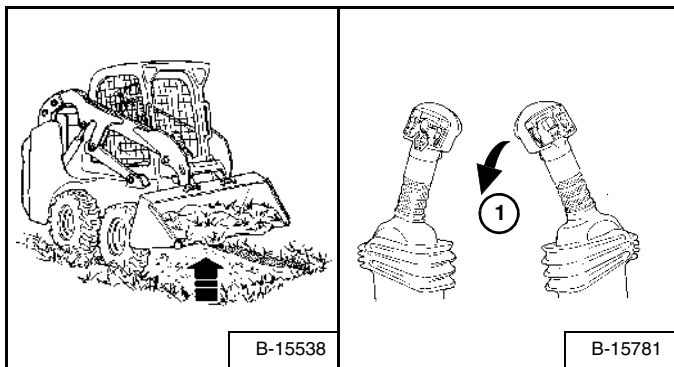

Tilt the bucket backward (1) [Figure 105] as far as it will go when the bucket is full.

#### Filling

Figure 106

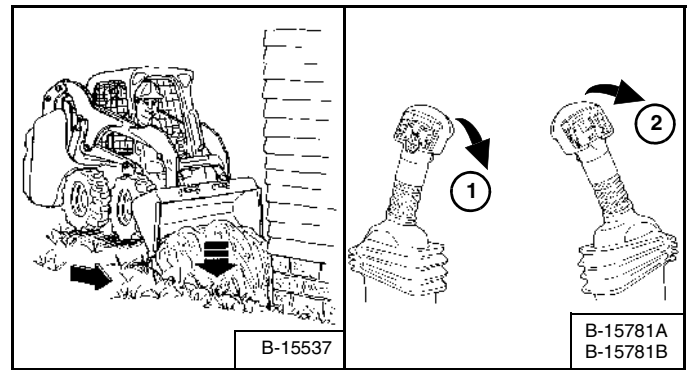

Lower the lift arms (1) [Figure 106] and put the cutting edge of the bucket on the ground (2) [Figure 106]. Drive forward to the edge of the hole to push the material into the hole.

Tilt the bucket forward (2) [Figure 106] as soon as it is past the edge of the hole.

If necessary, raise the lift arms to empty the bucket.

## OPERATING PROCEDURE (CONT'D)

### Filling And Emptying The Bucket (SJC - 'ISO' Pattern)

#### Filling

Figure 107

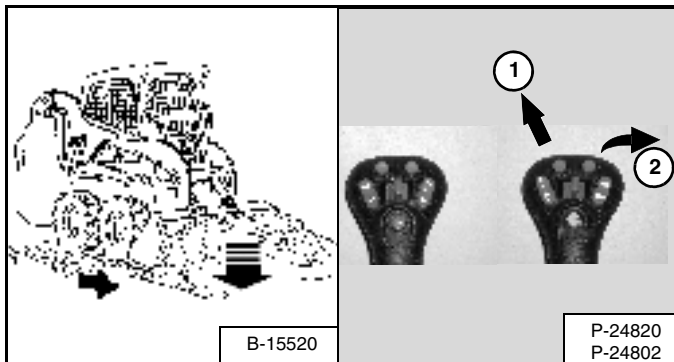
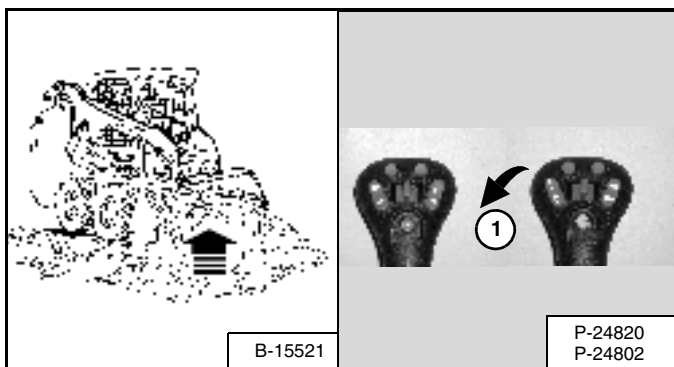

Figure 108



Lower the lift arms all the way (1) [Figure 107].

Tilt the bucket forward (2) [Figure 107] until the cutting edge of the bucket is on the ground.

Drive slowly forward into the material. Tilt the bucket backward (1) [Figure 108] all the way when the bucket is full.

Drive backward away from the material.

## ! WARNING

Load, unload and turn on flat level ground. Do not exceed Rated Operating Capacity shown on sign (decal) in cab. Failure to obey warnings can cause the machine to tip or roll over and cause injury or death.

W-2056-0903

#### Emptying

Figure 109

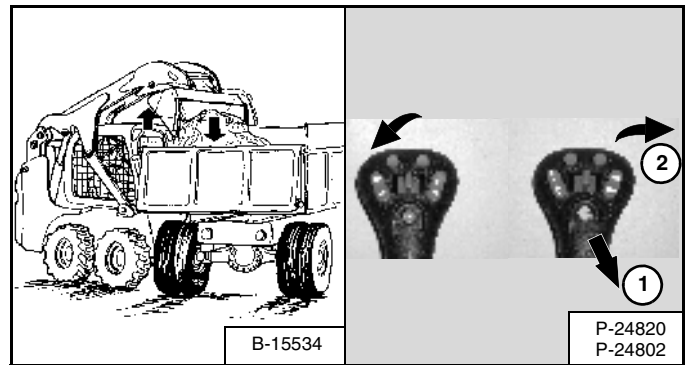

Keep the bucket low when moving to the area where you want to empty the bucket.

Raise the lift arms (1) [Figure 109]. Level the bucket (2) [Figure 109] while raising the lift arms to help prevent material from falling off the back of the bucket.

Drive forward slowly until the bucket is over the top of the truck box or bin.

Empty the bucket (2) [Figure 109]. If all material is near the side of the truck or bin, use the bucket tilt to move it to the other side.

## ! WARNING

Never dump over an obstruction, such as a post, that can enter the operator cab. The machine could tip forward and cause injury or death.

W-2057-0694



## OPERATING PROCEDURE (CONT'D)

### Leveling The Ground Using Float (SJC - 'ISO' Pattern)

Figure 110

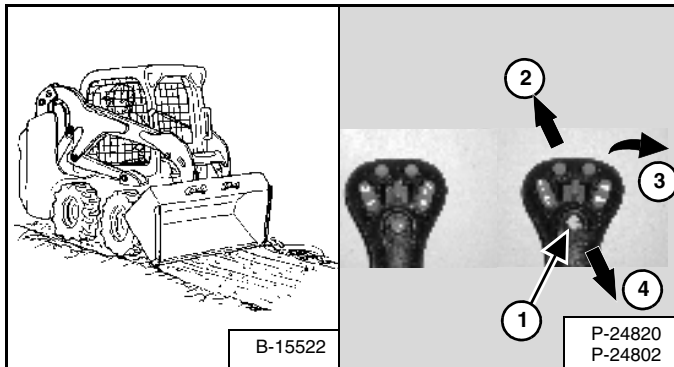

Press and hold the float button (1) [Figure 110] while the joystick is in neutral. While lowering the lift arms (2) [Figure 110], release the float button.

Tilt the bucket forward (3) [Figure 110] to change the position of the cutting edge of the bucket.

With the bucket tilted farther forward, there is more force on the cutting edge and more loose material can be moved.

Drive backward to level loose material.

To disengage, press the float button again or raise the lift arms (4) [Figure 110].

# IMPORTANT

Never drive forward when the hydraulic control for lift arms is in float position.

I-2005-1285

## OPERATING PROCEDURE (CONT'D)

### Digging And Filling A Hole (SJC - 'ISO' Pattern)

#### Digging

Figure 111

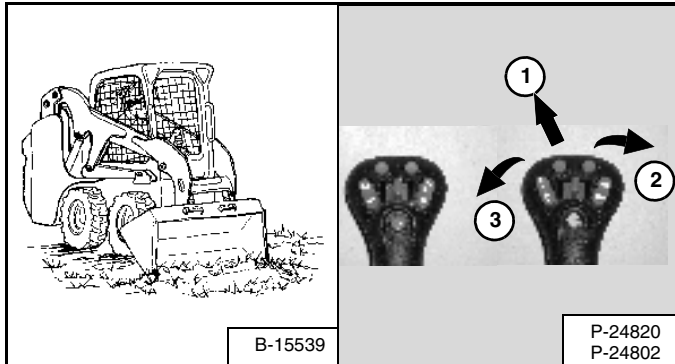

Lower the lift arms all the way (1) [Figure 111]. Put the cutting edge of the bucket on the ground (2) [Figure 111].

Drive forward slowly and continue to tilt the bucket down (2) [Figure 111] until it enters the ground.

Raise the cutting edge a small amount (3) [Figure 111] to increase traction and keep an even digging depth. Continue to drive forward until the bucket is full. When the ground is hard, raise and lower the cutting edge (2 and 3) [Figure 111] while driving forward.

Tilt the bucket backward (3) [Figure 111] as far as it will go when the bucket is full.

#### Filling

Figure 112

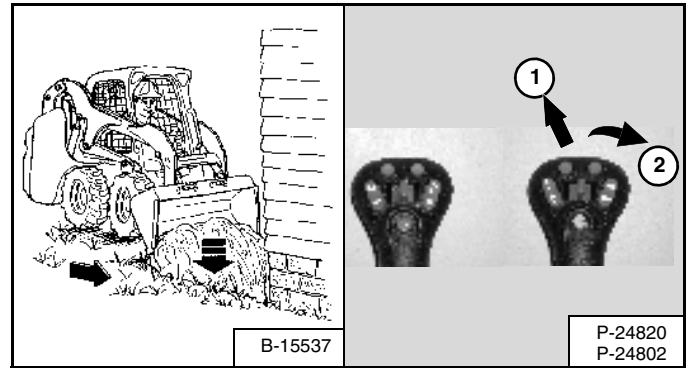

Lower the lift arms (1) [Figure 112] and put the cutting edge of the bucket on the ground (2) [Figure 112]. Drive forward to the edge of the hole to push the material into the hole.

Tilt the bucket forward (2) [Figure 112] as soon as it is past the edge of the hole.

If necessary, raise the lift arms to empty the bucket.

## TOWING THE LOADER

### Procedure

Because of the design of the loader, there is not a recommended towing procedure.

- The loader can be lifted onto a transport vehicle.
- The loader can be skidded a short distance to move for service (EXAMPLE: Move onto a transport vehicle) without damage to the hydrostatic system. (The tires / tracks will not turn.) There might be slight wear to the tires / tracks when the loader is skidded.

The towing chain (or cable) must be rated at 1 & 1/2 times the weight of the loader. (See Machine Rating on Page 120.)

## LIFTING THE LOADER

### Single Point Lift

# ! WARNING

### AVOID INJURY OR DEATH

- Before lifting, check fasteners on single point lift and operator cab.
- Assemble front cab fasteners as shown in this manual.
- Never allow riders in the cab or bystanders within 5 meters while lifting the machine.

W-2007-0497

The loader can be lifted with the Single Point Lift which is available as a kit from your Bobcat Loader dealer.

Figure 113

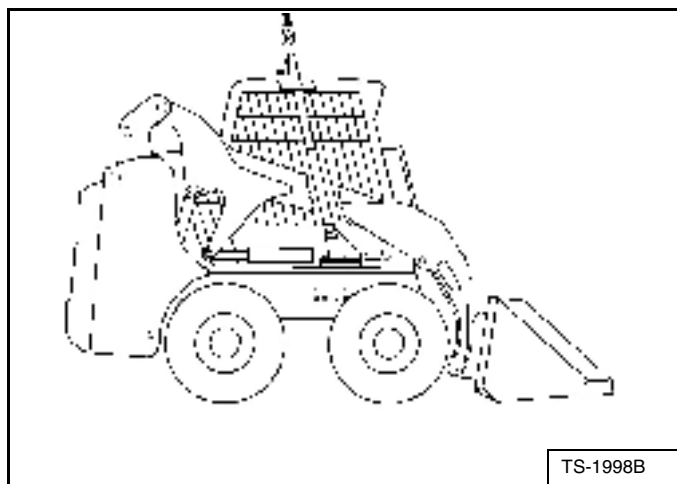

Install the kit as explained in the Instructions with the kit and attach lift as shown [Figure 113].

The Single Point Lift, supplied by Bobcat, is designed to lift and support the Bobcat Loader without affecting roll over and falling object protection features of the operator cab.

### Four Point Lift

# ! WARNING

### AVOID INJURY OR DEATH

- Before lifting, check fasteners on four point lift.
- Never allow riders in the cab or bystanders within 5 meters while lifting the machine.

W-2160-0694

The loader can be lifted with the Four Point Lift which is available as a kit from your Bobcat Loader dealer. The backhoe mounting kit must also be installed to provide lift points at the front of the loader.

Figure 114

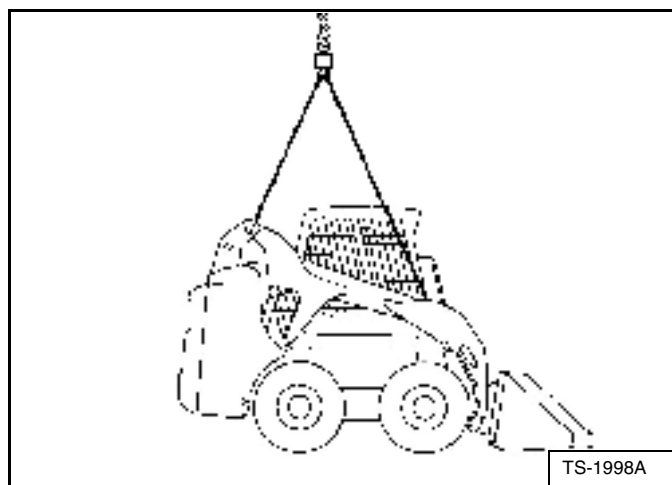

Attach cables or chains to lift eyes [Figure 114].

## TRANSPORTING THE LOADER ON A TRAILER

### Loading And Unloading

# ! WARNING

Adequately designed ramps of sufficient strength are needed to support the weight of the machine when loading onto a transport vehicle. Wood ramps can break and cause personal injury.

W-2058-0494

Be sure the transport and towing vehicles are of adequate size and capacity. (See Fluid Capacities on Page 122.)

Figure 115

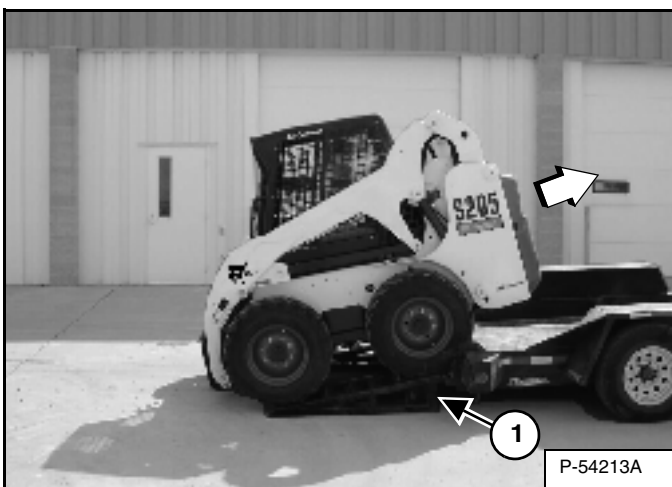

A loader with an empty bucket or no attachment must be loaded backward onto the transport vehicle [Figure 115].

The rear of the trailer must be blocked or supported (1) [Figure 115] when loading or unloading the loader to prevent the front end of the trailer from raising up.

## Fastening

Figure 116

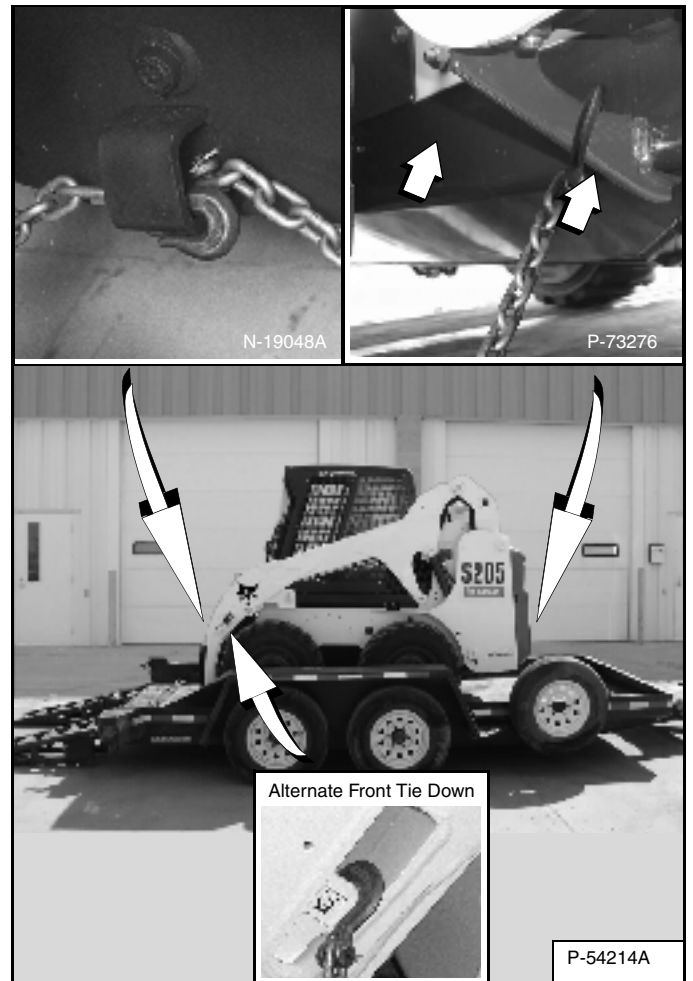

Use the following procedure to fasten the Bobcat Loader to the transport vehicle to prevent the loader from moving during sudden stops or when going up or down slopes [Figure 116].

- Lower the bucket or attachment to the floor.
- Stop the engine.
- Engage the parking brake.
- Install chains at the front and rear loader tie down positions (Inset) [Figure 116].
- Fasten each end of the chain to the transport vehicle.



**Bobcat®**

## PREVENTIVE MAINTENANCE

AIR CLEANER SERVICE.....	77
Replacing Filter Elements .....	77
AIR CONDITIONING BELT .....	95
Belt Adjustment.....	95
Belt Replacement.....	95
ALTERNATOR BELT .....	95
Belt Adjustment.....	95
Belt Replacement.....	95
BOB-TACH (HAND LEVER) .....	100
Inspection And Maintenance.....	100
BOB-TACH (POWER - OPTION).....	101
Inspection And Maintenance.....	101
BOBCAT INTERLOCK CONTROL SYSTEM (BICS) .....	66
Inspecting Deactivation Of Lift And Tilt Functions (ACS and SJC) .....	66
Inspecting Deactivation Of The Auxiliary Hydraulics System (Engine STOPPED - Key ON) .....	66
Inspecting The BICS Controller (Engine STOPPED - Key ON) .....	66
Inspecting The Lift Arm By-Pass Control .....	66
Inspecting The Seat Bar Sensor (Engine RUNNING).....	66
Inspecting The Traction Lock (Engine RUNNING) .....	66
DRIVE BELT .....	96
Belt Adjustment.....	96
Belt Replacement.....	96
ELECTRICAL SYSTEM .....	84
Battery Maintenance .....	85
Description .....	84
Fuse And Relay Location / Identification.....	84
Removing And Installing Battery.....	87
Using A Booster Battery (Jump Starting) .....	85
ENGINE COOLING SYSTEM .....	82
Checking Level.....	82
Cleaning.....	82
Removing And Replacing the Coolant .....	83
ENGINE LUBRICATION SYSTEM .....	81
Checking And Adding Engine Oil.....	81
Engine Oil Chart.....	81
Removing And Replacing Oil And Filter.....	81

**PREVENTIVE  
MAINTENANCE**

## PREVENTIVE MAINTENANCE (CONT'D)

FINAL DRIVE TRANSMISSION (CHAINCASE) .....	94
Checking And Adding Oil.....	94
Removing Oil From The Chaincase.....	94
FUEL SYSTEM.....	79
Filling the Fuel Tank.....	79
Fuel Filter.....	80
Fuel Specifications .....	79
Removing Air From The Fuel System.....	80
HEATING AND AIR CONDITIONING .....	76
Air Conditioning Lubrication.....	76
Cleaning and Maintenance.....	76
Evaporator .....	76
Filters.....	76
Troubleshooting .....	76
HYDRAULIC / HYDROSTATIC SYSTEM.....	88
Breather Cap .....	91
Checking And Adding Fluid .....	88
Hydraulic / Hydrostatic Fluid Chart.....	88
Removing And Replacing Charge Filter .....	90
Removing And Replacing Hydraulic Fluid And Case Drain Filters .....	89
Removing And Replacing Hydraulic / Hydrostatic Filter .....	88
LIFT ARM SUPPORT DEVICE.....	69
Installing .....	69
Removing .....	70
LOADER STORAGE AND RETURN TO SERVICE.....	102
Return to Service.....	102
Storage.....	102
LUBRICATING THE LOADER .....	97
Lubrication Locations.....	97
MAINTENANCE SAFETY.....	63
OPERATOR CAB .....	71
Cab Door Sensor (If Equipped) .....	73
Description.....	71
Lowering .....	72
Raising.....	71
PIVOT PINS .....	99
Inspection And Maintenance .....	99
REAR DOOR .....	74
Adjusting.....	74
Opening And Closing.....	74



## PREVENTIVE MAINTENANCE (CONT'D)

REAR GRILL .....	75
Installing .....	75
Removing .....	75
SEAT BAR RESTRAINT SYSTEM .....	67
Description .....	67
Inspecting .....	67
Maintaining .....	67
SEAT BELT .....	68
Inspection and Maintenance .....	68
SERVICE SCHEDULE .....	65
Chart .....	65
SPARK ARRESTOR MUFFLER .....	92
Cleaning Procedure .....	92
TIRE MAINTENANCE .....	93
Mounting .....	93
Rotating .....	93
Wheel Nuts .....	93



**Bobcat®**

# MAINTENANCE SAFETY



## WARNING

Instructions are necessary before operating or servicing machine. Read and understand the Operation & Maintenance Manual, Operator's Handbook and signs (decals) on machine. Follow warnings and instructions in the manuals when making repairs, adjustments or servicing. Check for correct function after adjustments, repairs or service. Untrained operators and failure to follow instructions can cause injury or death.

W-2003-0903



**Safety Alert Symbol:** This symbol with a warning statement, means: "Warning, be alert! Your safety is involved!" Carefully read the message that follows.

### CORRECT



B-10731A

- ⚠ Never service the Bobcat Skid-Steer Loader without instructions.

### CORRECT



B-15535

- ⚠ Use the correct procedure to lift or lower operator cab.

### CORRECT

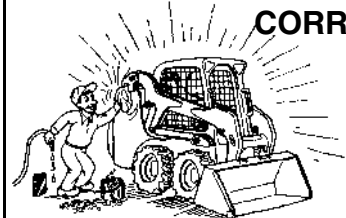

B-15524

- ⚠ Cleaning and maintenance are required daily.

### WRONG

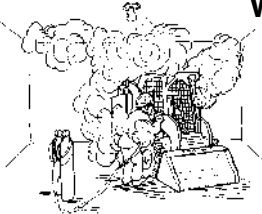

B-15734

- ⚠ Have good ventilation when welding or grinding painted parts.
- ⚠ Wear dust mask when grinding painted parts. Toxic dust and gas can be produced.
- ⚠ Avoid exhaust fume leaks which can kill without warning. Exhaust system must be tightly sealed.

### WRONG

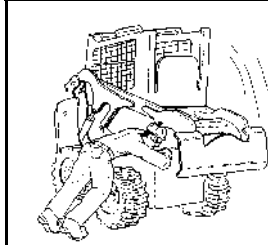

B-15732

- ⚠ Disconnecting or loosening any hydraulic tubeline, hose, fitting, component or a part failure can cause lift arms to drop. Do not go under lift arms when raised unless supported by an approved lift arm support device. Replace it if damaged.

### WRONG

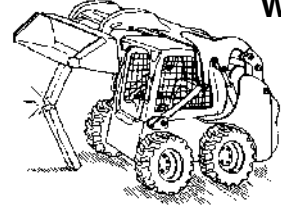

B-15525

- ⚠ Never work on loader with lift arms up unless lift arms are held by an approved lift arm support device. Replace if damaged.
- ⚠ Never modify equipment or add attachments not approved by Bobcat Company.

### WRONG

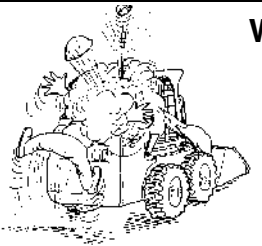

B-15733

- ⚠ Stop, cool and clean engine of flammable materials before checking fluids.
- ⚠ Never service or adjust loader with the engine running unless instructed to do so in the manual.
- ⚠ Avoid contact with leaking hydraulic fluid or diesel fuel under pressure. It can penetrate the skin or eyes.
- ⚠ Never fill fuel tank with engine running, while smoking or when near open flame.

### WRONG

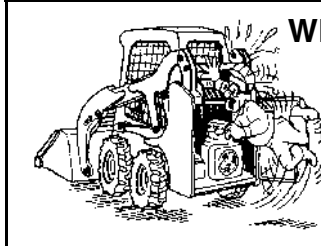

B-15523

- ⚠ Keep body, jewelry and clothing away from moving parts, electrical contact, hot parts and exhaust.
- ⚠ Wear eye protection to guard from battery acid, compressed springs, fluids under pressure and flying debris when engines are running or tools are used. Use eye protection approved for type of welding.
- ⚠ Keep rear door closed except for service. Close and latch door before operating the loader.

### WRONG



B-6589

- ⚠ Lead-acid batteries produce flammable and explosive gases.
- ⚠ Keep arcs, sparks, flames and lighted tobacco away from batteries.
- ⚠ Batteries contain acid which burns eyes or skin on contact. Wear protective clothing. If acid contacts body, flush well with water. For eye contact flush well and get immediate medical attention.

Maintenance procedures which are given in the Operation & Maintenance Manual can be performed by the owner / operator without any specific technical training. Maintenance procedures which are **not** in the Operation & Maintenance Manual must be performed **ONLY BY QUALIFIED BOBCAT SERVICE PERSONNEL**. Always use **genuine Bobcat replacement parts**. The Service Safety Training Course is available from your Bobcat dealer.

MSW07-0805



**Bobcat<sup>®</sup>**

## SERVICE SCHEDULE

### Chart

Maintenance work must be done at regular intervals. Failure to do so will result in excessive wear and early failures. The service schedule is a guide for correct maintenance of the Bobcat loader.

 <h1 style="margin: 0;">WARNING</h1>	<p><b>Instructions are necessary before operating or servicing machine. Read and understand the Operation &amp; Maintenance Manual, Operator's Handbook and signs (decals) on machine. Follow warnings and instructions in the manuals when making repairs, adjustments or servicing. Check for correct function after adjustments, repairs or service. Untrained operators and failure to follow instructions can cause injury or death.</b></p> <p style="text-align: right;"><b>W-2003-0903</b></p>
-----------------------------------------------------------------------------------------------------------------------	--------------------------------------------------------------------------------------------------------------------------------------------------------------------------------------------------------------------------------------------------------------------------------------------------------------------------------------------------------------------------------------------------------------------------------------------------------------------------------------------------------

SERVICE SCHEDULE		HOURS					
ITEM	SERVICE REQUIRED	8-10	50	100	■ 250	■ 500	■ 1000
Engine Oil	Check the oil level and add as needed. Do not overfill.						
Engine Air Filter and Air System	Check display panel. Service only when required. Check for leaks and damaged components.						
Engine Cooling System	Clean debris from oil cooler, radiator & grill. Check coolant level COLD and add premixed coolant as needed.						
Fuel Filter	Remove the trapped water.						
Lift Arms, Cylinders, Bob-Tach Pivot Pins and Wedges	Lubricate with multi-purpose lithium based grease.						
Tires	Check for damaged tires and correct air pressure. Inflate to MAXIMUM pressure shown on sidewall of tire.						
Seat Belt, Seat Bar, Control Interlocks, Seat Belt Retractors	Check the condition of seat belt. Check the seat bar and control interlocks for correct operation. Clean dirt and debris from moving parts. Clean or replace seat belt retractors as needed.						
Bobcat Interlock Control Systems (BICS™)	Check that four BICS indicator lights and functions are activated. See details in this Manual.						
Safety Signs and Safety Treads	Check for damaged signs (decals) and safety treads. Replace any signs or safety treads that are damaged or worn.						
Operator Cab	Check the fastening bolts, washers and nuts. Check the condition of the cab.						
Indicators and Lights	Check for correct operation of all indicators and lights.						
Heater and A/C Filters (If Equipped)	Clean or replace filters as needed.						
Hydraulic Fluid, Hoses and Tubelines	Check fluid level and add as needed. Check for damage and leaks. See your Bobcat dealer for repair or replacement as needed.						
Final Drive Trans. (Chaincase), Foot Pedals, Hand Controls or Steering Levers	Check oil level and add oil as needed. Check for correct operation. See your Bobcat dealer for repair or adjustment as needed.						
Parking Brake	Check operation.						
Wheel Nuts	Check for loose wheel nuts and tighten to correct torque. (See TIRE MAINTENANCE on Page 93.)	□					
Spark Arrestor Muffler	Clean the spark chamber.						
Battery	Check cables, connections and electrolyte level. Add distilled water as needed.						
Steering Lever Pivots	Grease fittings.						
Fuel Filter	Replace filter element.						
Engine / Hydro. Drive Belt	Check for wear or damage.		○				
Alternator Belt	Check condition and tension. Adjust as needed.						
Bobcat Interlock Control System (BICS™)	Check the function of the lift arm by-pass control.						
Engine Oil and Filter	Replace oil and filter. Use CD or better grade oil and Bobcat filter.		*				
Hydraulic/Hydrostatic Filter, Charge Filter, Reservoir Breather	Replace the hydrostatic filter, charge filter and the reservoir breather.		▼				
Engine Valves	Adjust the engine valves. See your Bobcat dealer for this service.						
Final Drive Trans. (Chaincase)	Replace the fluid.						
Hydraulic Reservoir	Replace the fluid.						
Case Drain Filters	Replace the filters.						
Coolant	Replace the coolant.	Every 2 years					

- Or every 12 months.
- Check every 8-10 hours for the first 24 hours; then at 50 hour intervals.
- Inspect new belt after first 50 hours.
- \* First oil and filter change must occur at 50 hours; 250 hours thereafter.
- ▼ Replace the hydraulic / hydrostatic filter element after the first 50 hours; and thereafter when the transmission warning light comes ON while operating or at the 500 hour interval.

## BOBCAT INTERLOCK CONTROL SYSTEM (BICS)

### Inspecting The BICS Controller (Engine STOPPED - Key ON)

Figure 117

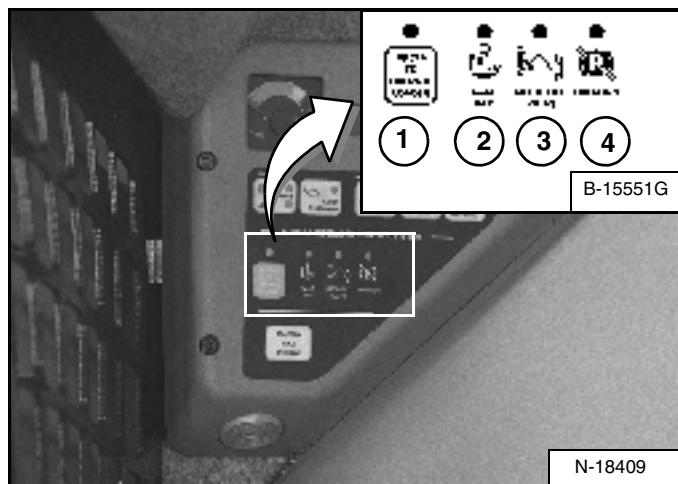

1. Sit in operator's seat. Turn key ON (*Key Switch Panel*), press RUN / ENTER Button (*Keyless Panel*), lower seat bar and disengage parking brake. Press the PRESS TO OPERATE LOADER Button. Three BICS lights (1, 2 and 3) [PRESS TO OPERATE LOADER, SEAT BAR, AND LIFT & TILT VALVE] on left instrument panel should be ON [Figure 117].
2. Raise seat bar fully. All four BICS lights (1, 2, 3 and 4) [PRESS TO OPERATE LOADER, SEAT BAR, LIFT & TILT VALVE AND TRACTION\*] on left instrument panel should be OFF [Figure 117].

**NOTE:** Record what lights are blinking (if any) and the number of light flashes. (See BOBCAT INTERLOCK CONTROL SYSTEM (BICS) on Page 105.)

### Inspecting Deactivation Of The Auxiliary Hydraulics System (Engine STOPPED - Key ON)

3. Sit in operator's seat, lower seat bar, and press the PRESS TO OPERATE LOADER Button. Press the auxiliary hydraulics FLOW Button. The auxiliary FLOW Button light will come ON. Raise the seat bar. The light should be OFF.

### Inspecting The Seat Bar Sensor (Engine RUNNING)

4. Sit in operator's seat, lower seat bar, engage parking brake and fasten seat belt.
5. Start engine and operate at low idle. Press the PRESS TO OPERATE LOADER Button. While raising the lift arms, raise the seat bar fully. The lift arms should stop. Repeat using the tilt function.

### Inspecting The Traction Lock (Engine RUNNING)

6. Fasten seat belt, disengage parking brake, press the PRESS TO OPERATE LOADER Button and raise seat bar fully. Move steering levers slowly forward and backward. The TRACTION lock should be engaged. Lower the seat bar. Press the PRESS TO OPERATE LOADER Button.
7. Engage parking brake and move steering levers slowly forward and backward. The TRACTION lock should be engaged.

**NOTE:** \*The TRACTION light on the left instrument panel will remain OFF until the engine is started, the PRESS TO OPERATE LOADER Button is pressed and the parking brake is disengaged.

### Inspecting The Lift Arm By-Pass Control

8. Raise the lift arms 2 meters off the ground. Stop engine. Turn lift arm by-pass control knob clockwise 1/4 turn. Pull up and hold lift arm by-pass control knob until lift arms slowly lower.

### Inspecting Deactivation Of Lift And Tilt Functions (ACS and SJC)

9. Sit in operator's seat and fasten seat belt. Lower seat bar, start engine and press the PRESS TO OPERATE LOADER Button.
10. Raise lift arms about 2 meters off the ground.
11. Turn key to OFF (*Key Switch Panel*), press STOP Button (*Keyless Panel*), and wait for the engine to come to a complete stop.
12. Turn key to ON (*Key Switch Panel*), press RUN / ENTER Button (*Keyless Panel*). Press the PRESS TO OPERATE LOADER Button, move hand control or joystick to lower the lift arms. Lift arms should not lower.
13. Move the control (foot pedal, hand control or joystick) to tilt the bucket (or attachment) forward. The bucket (or attachment) should not tilt forward.

**! WARNING**

**AVOID INJURY OR DEATH**

**The Bobcat Interlock Control System (BICS) must deactivate the lift, tilt and traction drive functions. If it does not, contact your dealer for service. DO NOT modify the system.**

W-2151-0394

## SEAT BAR RESTRAINT SYSTEM

### Description

The seat bar restraint system has a pivoting seat bar with arm rests.

The operator controls the use of the seat bar. The seat bar in the down position helps to keep the operator in the seat.

**Models with foot pedals** have hydraulic valve spool interlocks for the lift and tilt functions. The spool interlocks require the operator to lower the seat bar in order to operate the foot pedal controls.

When the seat bar is down, the PRESS TO OPERATE LOADER Button is activated and the engine is running, the lift, tilt and traction drive functions can be operated.

When the seat bar is up, the lift and tilt control pedals are locked when returned to the NEUTRAL position.

**Models with the Advanced Control System (ACS)** have mechanical interlocks for the handles and pedals. The interlocks for the handles and pedals require the operator to lower the seat bar in order to operate the selected controls.

When the seat bar is down, the PRESS TO OPERATE LOADER button is activated and the engine is running, the lift, tilt and traction drive functions can be operated using the selected controls (handles, or foot pedals).

When the seat bar is up, the handles and pedals are locked when returned to the NEUTRAL position.

**Models with Selectable Joystick Control (SJC)** have electrical deactivation of joystick functions. Activation of functions require the operator to lower the seat bar.

When the seat bar is down, the PRESS TO OPERATE LOADER button is activated and the engine is running, the lift, tilt and traction drive functions can be operated.

When the seat bar is up, the joystick functions are deactivated even though the joystick does not mechanically lock.

### Inspecting

Sit in the seat and fasten the seat belt. Engage the parking brake. Pull the seat bar all the way down. Start the engine. Press the PRESS TO OPERATE LOADER Button.

Operate the hydraulic controls to check that both the lift and tilt functions operate correctly. Raise the lift arms until the attachment is about 600 mm off the ground.

Raise the seat bar. Move the hydraulic controls. Pedals and handles (if equipped) must be firmly locked in the NEUTRAL position (except joysticks). There must be no motion of the lift arms or tilt (attachment) when the controls are moved.

Lower the seat bar, press the PRESS TO OPERATE LOADER Button, lower the lift arms. Operate the lift control. While the lift arms are going up, raise the seat bar. The lift arms must stop.

Lower the seat bar, press the PRESS TO OPERATE LOADER Button, lower the lift arms and put the attachment flat on the ground. Stop the engine. Raise the seat bar. Operate the foot pedals and handles (if equipped) to be sure they are firmly locked in the NEUTRAL position (except joysticks).

### Maintaining

(See SERVICE SCHEDULE on Page 65) and on the loader for correct service interval.

Figure 118

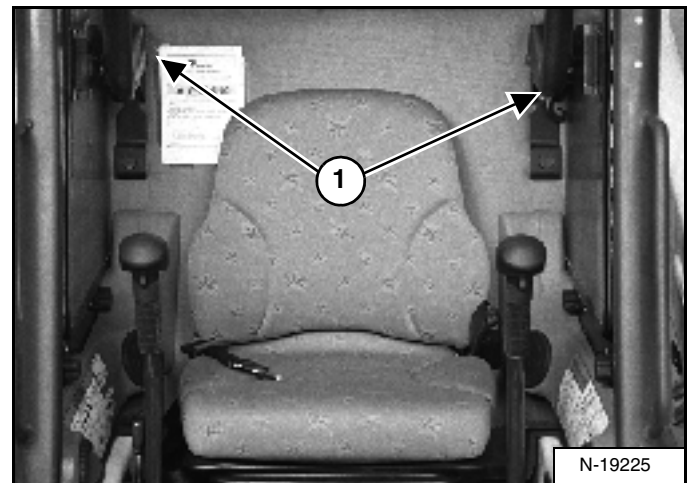

Use compressed air to clean any debris or dirt from the pivot parts (1) [Figure 118]. Do not lubricate. Inspect all mounting hardware. The correct bolt torque is 35 Nm.

If the seat bar system does not function correctly, replace parts that are worn or damaged. Use only genuine Bobcat replacement parts.

**! WARNING**

**The seat bar system must deactivate the lift and tilt control functions when the seat bar is up. Service the system if hydraulic controls do not deactivate.**

W-2465-0703

## SEAT BELT

### Inspection and Maintenance

# WARNING

Failure to properly inspect and maintain the seat belt can cause lack of operator restraint resulting in serious injury or death.

W-2466-0703

Check the seat belt daily for correct function.

Inspect the seat belt system thoroughly at least once each year or more often if the machine is exposed to severe environmental conditions or applications.

Any seat belt system that shows cuts, fraying, extreme or unusual wear, significant discolorations due to ultraviolet (UV) exposure, dusty / dirty conditions, abrasion to the seat belt webbing, or damage to the buckle, latch plate, retractor (if equipped), hardware or any other obvious problem should be replaced immediately.

The items below are referenced in **[Figure 119]**.

1. Check the webbing. If the system is equipped with a retractor, pull the webbing completely out and inspect the full length of the webbing. Look for cuts, wear, fraying, dirt and stiffness.
2. Check the buckle and latch for correct operation. Make sure latch plate is not excessively worn, deformed or buckle is not damaged or casing broken.
3. Check the retractor web storage device (if equipped) by extending webbing to determine if it looks correct and that it spools out and retracts webbing correctly.
4. Check webbing in areas exposed to ultraviolet (UV) rays from the sun or extreme dust or dirt. If the original color of the webbing in these areas is extremely faded and / or the webbing is packed with dirt, the webbing strength may have deteriorated.

See your Bobcat dealer for seat belt system replacement parts for your machine.

Figure 119

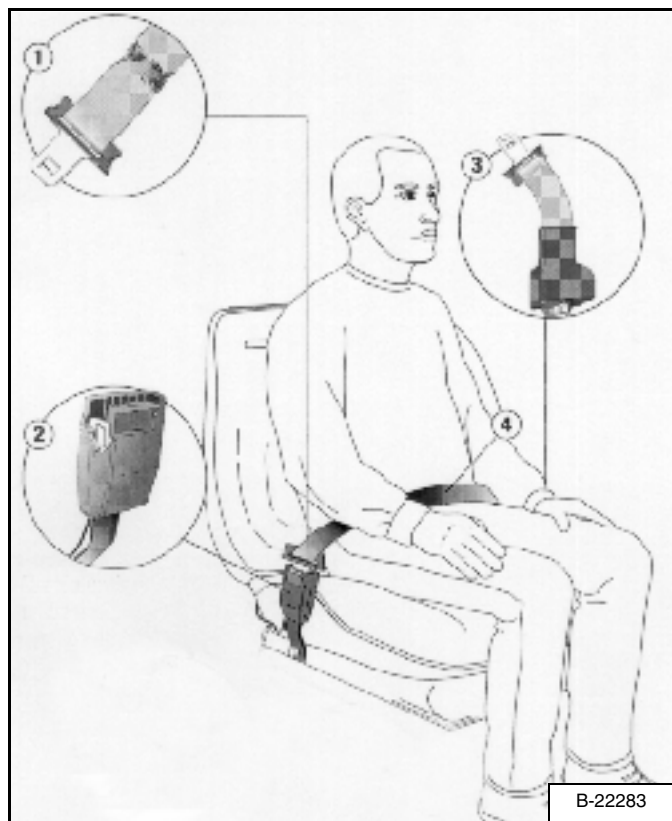



## LIFT ARM SUPPORT DEVICE

### Installing

# ! WARNING

Never work on a machine with the lift arms up unless the lift arms are secured by an approved lift arm support device. Failure to use an approved lift arm support device can allow the lift arms or attachment to fall and cause injury or death.

W-2059-0598

# ! WARNING

Service lift arm support device if damaged or if parts are missing. Using a damaged lift arm support or with missing parts can cause lift arms to drop causing injury or death.

W-2271-1197



Figure 120

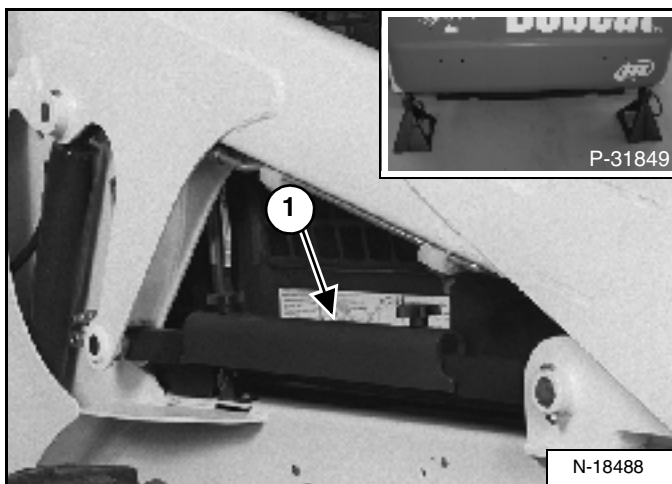

Put jackstands under the rear corners of the loader frame (Inset) [Figure 120].

Remove the lift arm support device (1) [Figure 120] from storage position.

The operator must be in the operator's seat, with the seat belt fastened and seat bar lowered, until the lift arm support device is installed.

Start the engine, and raise the lift arms all the way up.

Figure 121

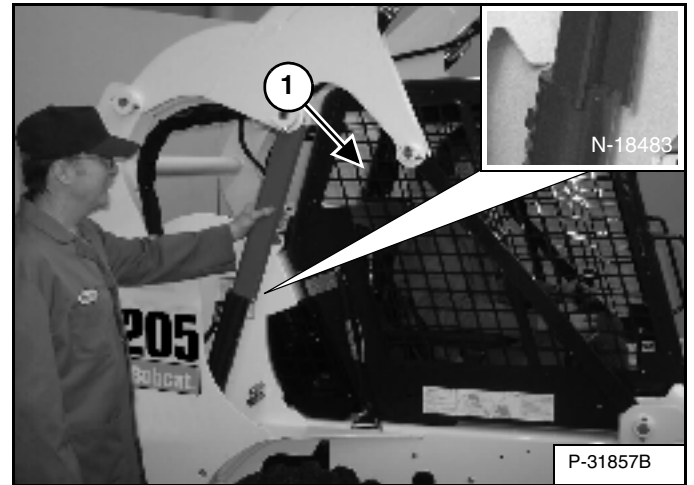

Have a second person install the lift arm support device (1) [Figure 121] over the rod of one of the lift cylinders.

The lift arm support device must be tight against the cylinder rod. The tabs of the lift arm support device must be under the cylinder as shown (Inset) [Figure 121].

Figure 122

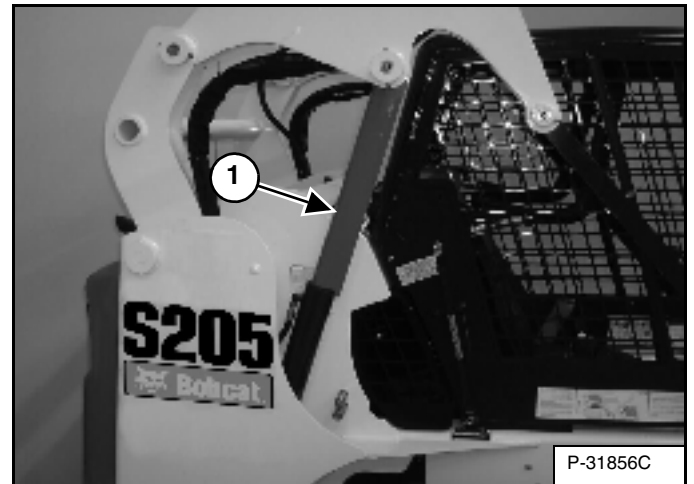

Lower the lift arms slowly until the lift arm support device (1) [Figure 122] is held between the lift arms and lift cylinder.

## **LIFT ARM SUPPORT DEVICE (CONT'D)**

### **Removing**

The operator must be in the operator's seat, with the seat belt fastened and seat bar lowered, until the lift arm support device is removed and the lift arms are lowered all the way.

Start the engine, raise the lift arms all the way up.

Have a second person remove the lift arm support device.

Lower the lift arms all the way and stop the engine.

Return the lift arm support device to storage position and secure with clamping knobs.

Remove the jackstands.

## OPERATOR CAB

### Description

The Bobcat Loader has an operator cab (ROPS and FOPS) as standard equipment to protect the operator from rollover and falling objects. Check with your dealer if the operator cab has been damaged. The seat belt must be worn for roll over protection.

ROPS / FOPS - Roll Over Protective Structure per SAE J1040 and ISO 3471, and Falling Object Protective Structure per SAE J1043 and ISO 3449, Level I. Level II is available.

*Level I* - Protection from falling bricks, small concrete blocks, and hand tools encountered in operations such as highway maintenance, landscaping, and other construction site services.

*Level II* - Protection from falling trees, rocks; for machines involved in site clearing, overhead demolition or forestry.

### Raising

Always stop the engine before raising or lowering the cab.

Stop the loader on a level surface. Lower the lift arms. If the lift arms must be up while raising the operator cab, install the lift arm support device. (See LIFT ARM SUPPORT DEVICE on Page 69.)

Figure 123



Install jackstands under the rear of the loader frame [Figure 123].

Loosen the nut (both sides) at the front corners of the operator cab [Figure 124].

Figure 124

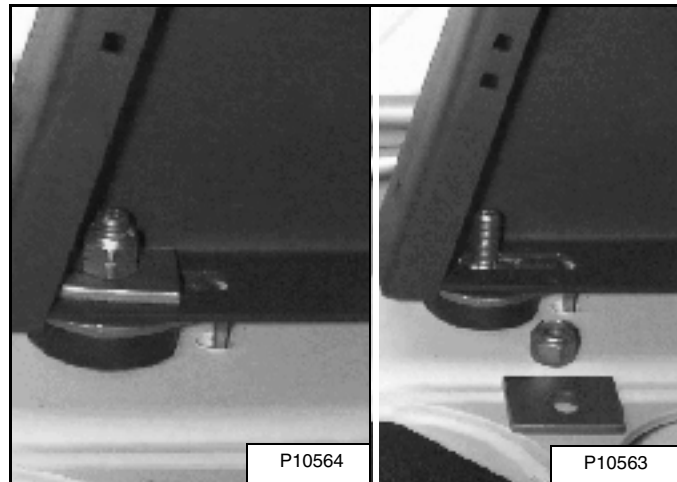

Remove the nuts and plates [Figure 124] (both sides).

Figure 125



Lift on the grab handle and bottom of the operator cab slowly until the cab is all the way up and the latching mechanism engages [Figure 125].

*Hand Controls Only (ACS)*



## OPERATOR CAB (CONT'D)

### Raising (Cont'd)

# ! WARNING

Never modify operator cab by welding, grinding, drilling holes or adding attachments unless instructed to do so by Bobcat. Changes to the cab can cause loss of operator protection from rollover and falling objects, and result in injury or death.

W-2069-1299



### Lowering

Always stop the engine before raising or lowering the cab.

**NOTE:** Always use the grab handles to lower the cab.

Figure 126

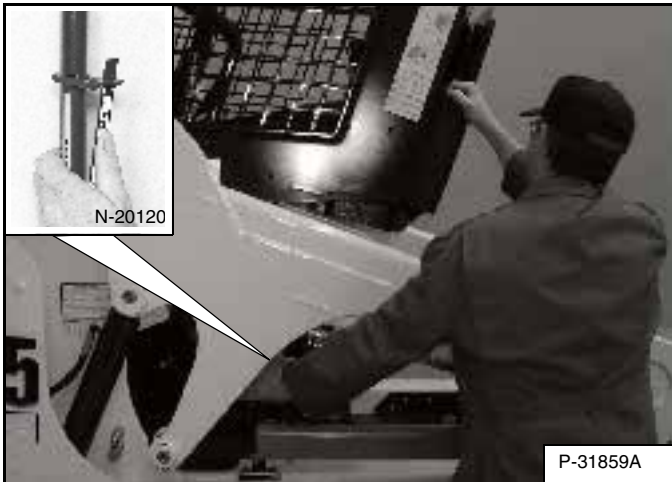

Pull down on the bottom of the operator cab until it stops at the latching mechanism [Figure 126].

**NOTE:** The weight of the cab increases when equipped with options and accessories such as cab door, heater, air conditioning, etc. In these cases, the cab may need to be raised slightly from the latch to be able to release the latch.

Support the cab and release the latching mechanism (Inset) [Figure 126]. Remove your hand from latching mechanism when the cab is past the latch stop. Use both hands to lower the cab all the way.

# ! WARNING

## PINCH POINT CAN CAUSE INJURY

Remove your hand from the latching mechanism when the cab is past the latch stop.

W-2469-0803

Figure 127

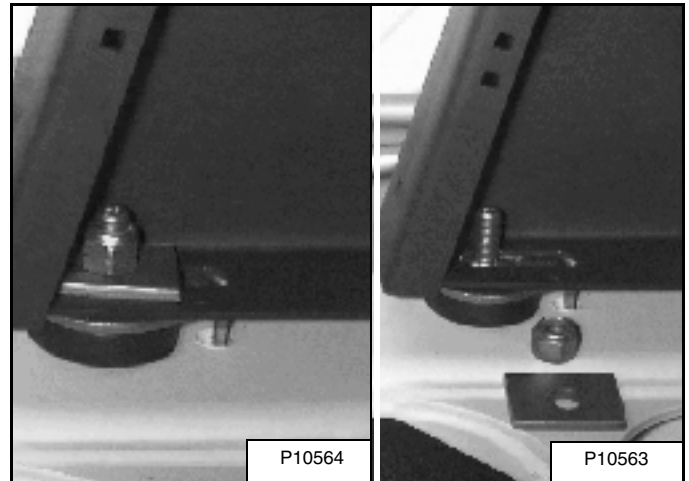

Install the plates and nuts [Figure 127] (both sides).

Tighten the nuts to 54-68 Nm torque.

## OPERATOR CAB (CONT'D)

### Cab Door Sensor (If Equipped)

Figure 128

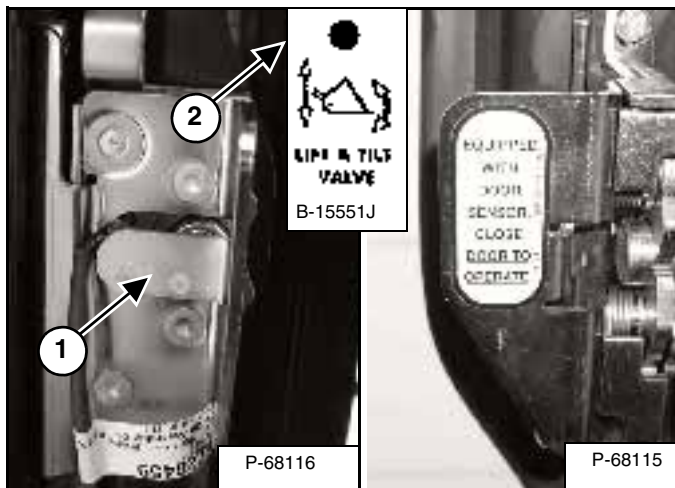

Cab doors have a sensor (1) [Figure 128] installed which deactivates the lift and tilt valves when the door is open.

CLOSE DOOR TO OPERATE lift and tilt valves.

The LIFT & TILT VALVE light (2) [Figure 128] will be ON when the door is closed and the PRESS TO OPERATE LOADER BUTTON is pressed.

## REAR DOOR

### Opening And Closing

# ! WARNING

## AVOID INJURY OR DEATH

Never service or adjust the machine when the engine is running unless instructed to do so in the manual.

W-2012-0497

Figure 129



Reach into the slot in the rear door and pull the latch handle [Figure 129].

Pull the rear door open.

Figure 130

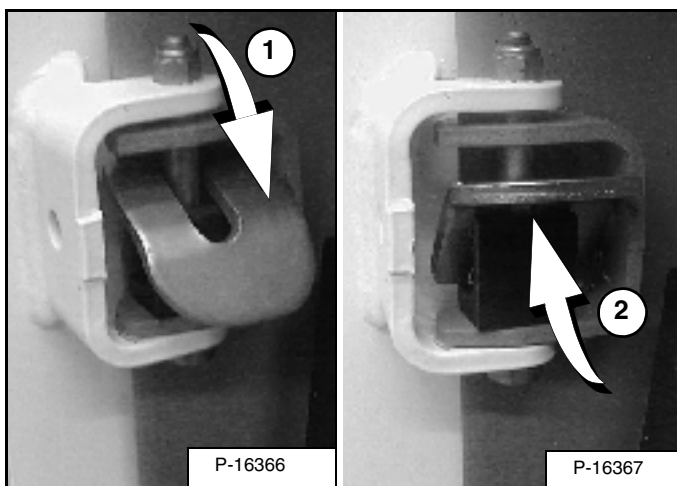

Move the door stop into the engaged position (1) [Figure 130] to hold the door open.

Move the door stop up (2) [Figure 130] to disengage the door stop and allow the door to close.

Close the door.

# ! WARNING

Keep the rear door closed when operating the machine. Failure to do so could seriously injure a bystander.

W-2020-1285

## Adjusting

Figure 131

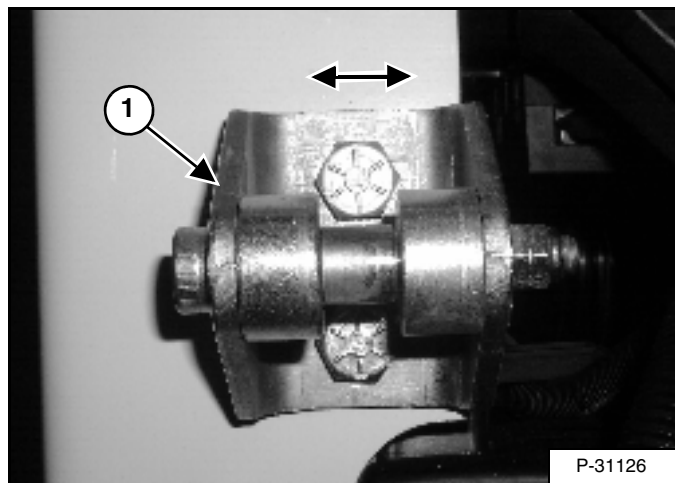

The door latch catch (1) [Figure 131] can be adjusted for alignment with the door latch mechanism.

Close the rear door before operating the loader.

## REAR GRILL

### Removing

Open the rear door.

**Figure 132**



Remove the rear grill [Figure 132].

### Installing

Align the tabs of the rear grill into the slots in the loader frame [Figure 132].

Lower the rear grill.



## HEATING AND AIR CONDITIONING

### Cleaning and Maintenance

The heater and air conditioning system require regular inspection and maintenance. See your SERVICE SCHEDULE for intervals. (See SERVICE SCHEDULE on Page 65.)

### Filters

Figure 133

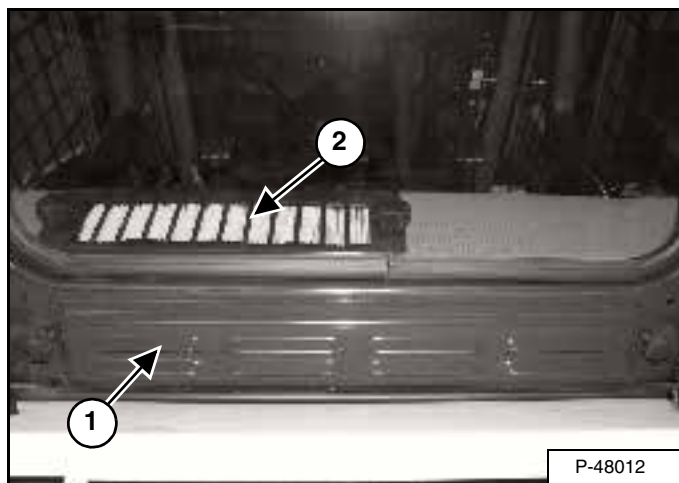

The *Fresh Air Filter* is located below the rear window of the cab (1) [Figure 133].

Remove the bolts and remove the filter housing.

Shake the filter or use low air pressure to remove dirt. Replace after cleaning three times or if filter becomes too dirty to clean.

Reinstall the filter, housing and bolts.

The *Recirculation Filter* is located in front of the rear window inside the cab (2) [Figure 133].

Remove the clamping knobs, grill and filter.

Clean the filter with water and mild detergent. Reinstall the filter. Replace after cleaning three times, or if filter becomes too dirty to clean.

### Evaporator

Figure 134

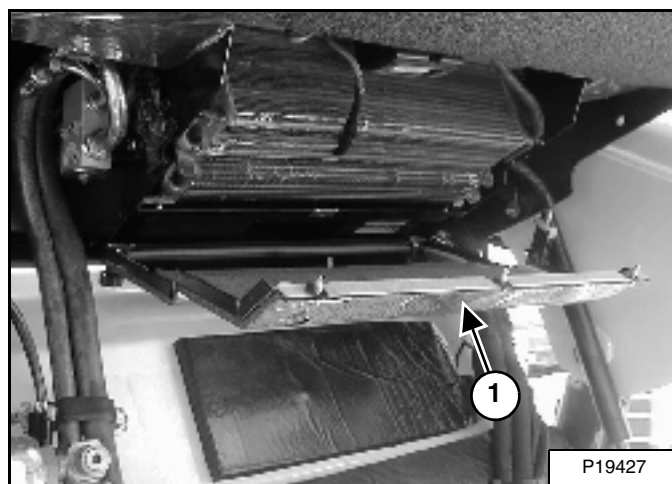

Raise the cab and remove the evaporator cover (1) [Figure 134].

Use low pressure water or air to remove debris from the evaporator fins.

Install the cover.

### Air Conditioning Lubrication

Run the air conditioner for about 5 minutes every week to lubricate the internal components. (In winter too.)

### Troubleshooting

If the fan does not run, or the air conditioning does not turn on, Check the fuse. (See ELECTRICAL SYSTEM on Page 84).

If the air conditioning system circulates warm air, the refrigerant may need to be recharged.



## AIR CLEANER SERVICE

### Replacing Filter Elements

Figure 135

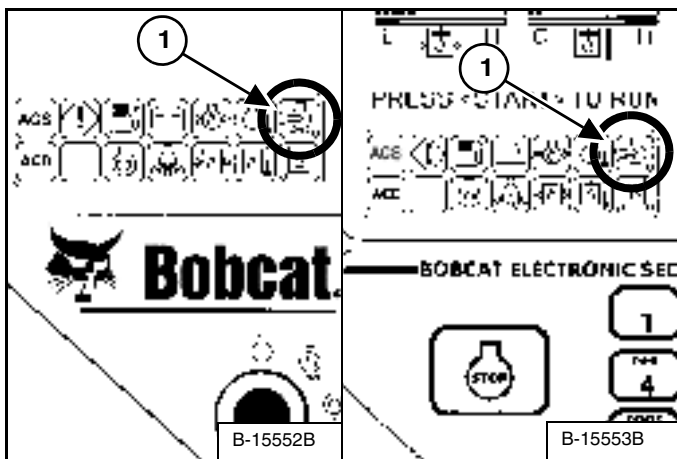

It is important to change the air filter element only when the Air Cleaner Icon in the right panel is ON (1) [Figure 135] and you hear three beeps from the alarm.

Replace the inner filter every third time the outer filter is replaced or as indicated.

Figure 136

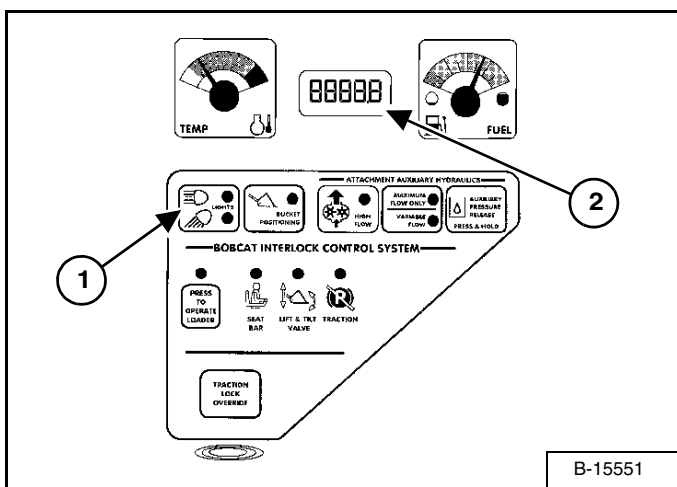

Press and hold the LIGHT Button (1) [Figure 136] for two seconds.

If the filter element needs replacement, the CODE [01-17] (Air Filter Plugged) will show in the HOURMETER / CODE DISPLAY (2) [Figure 136].

### Outer Filter

Figure 137



Remove the wing nut and remove the dust cover [Figure 137].

Figure 138

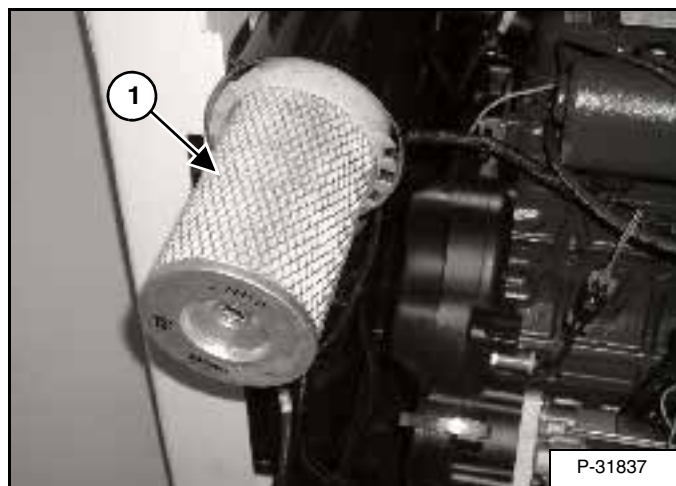

Remove the wing nut and remove the outer filter element (1) [Figure 138].

**NOTE: Make sure all sealing surfaces are free of dirt and debris. Do not use air pressure to clean.**

Install a new outer element.

Install the dust cover and the wing nut [Figure 137] (Be sure the evacuator is down).

Check the air intake hose and the air cleaner housing for damage. Make sure all connections are tight.

## AIR CLEANER SERVICE (CONT'D)

### Replacing Filter Elements (Cont'd)

#### Inner Filter

Only replace the inner filter element under the following conditions:

- Replace the inner filter element every *third* time the outer filter is replaced.
- After the outer element has been replaced, start the engine and run at full RPM. If the HOURMETER / CODE DISPLAY shows **[01-17]** (Air Filter Plugged), replace the inner filter element.

**Figure 139**

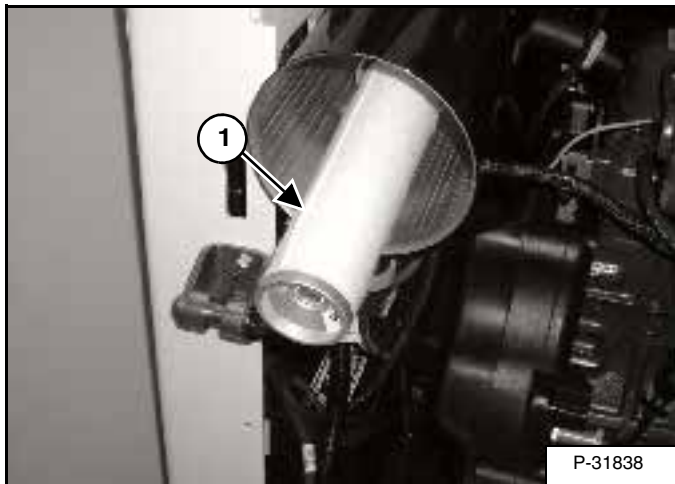

Remove the wing nut and remove the inner filter element (1) **[Figure 139]**.

**NOTE: Make sure all sealing surfaces are free of dirt and debris.**

Install the new inner element.

Install the outer element.

**Figure 140**

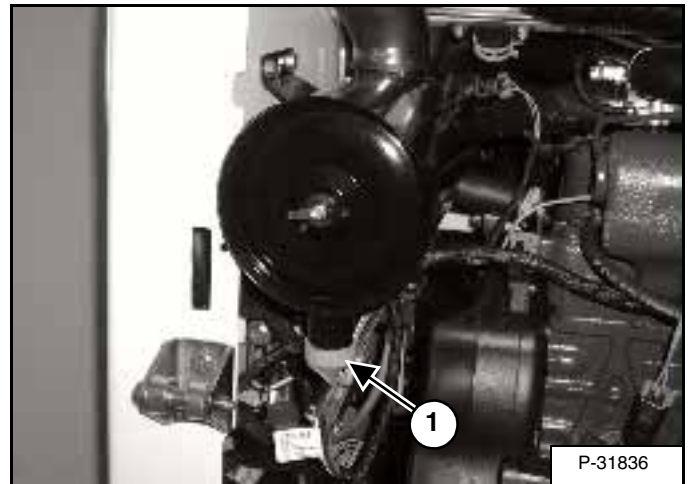

Install the dust cover and the wing nut **[Figure 140]** (Be sure the evacuator (1) **[Figure 140]** is down).

## FUEL SYSTEM

### Fuel Specifications

Use only clean, high quality diesel fuel, Grade No. 2 or Grade No. 1.

The following is one suggested blending guideline which should prevent fuel gelling during cold temperatures:

TEMPERATURE °C (°F)	No. 2	No. 1
-9° (+15°)	100%	0%
Down to -29° (-20°)	50%	50%
Below -29° (-20°)	0%	100%

Contact your fuel supplier for local recommendations.

### Filling the Fuel Tank

## WARNING

Stop and cool the engine before adding fuel. **NO SMOKING!** Failure to obey warnings can cause an explosion or fire.

W-2063-0887

Figure 141

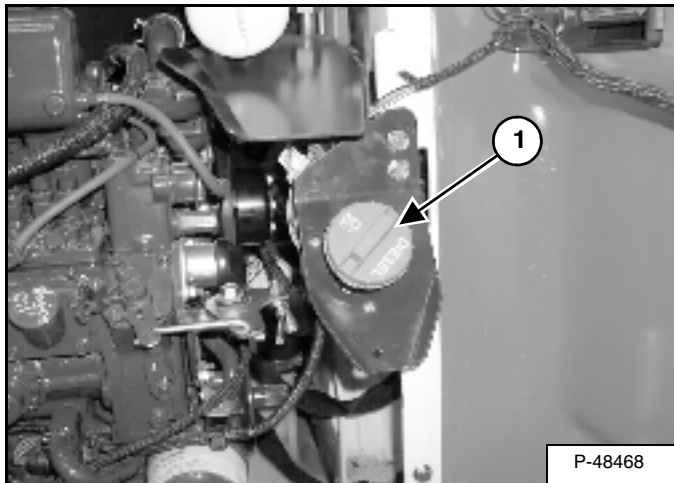

Open the rear door.

Remove the fuel fill cap (1) [Figure 141].

Figure 142

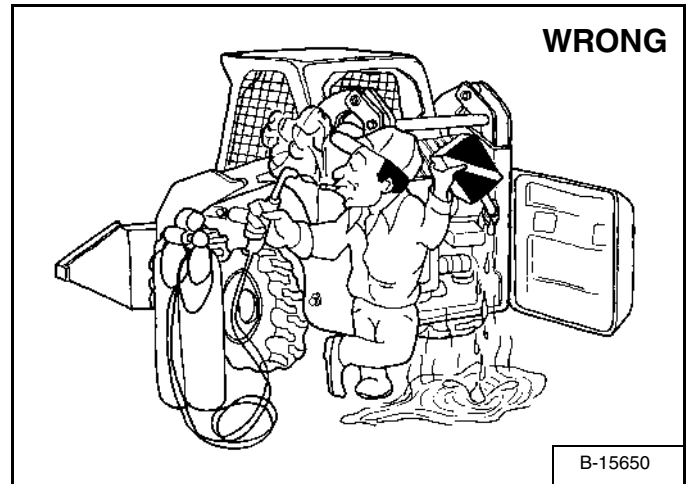

Use a clean, approved safety container to add fuel of the correct specifications. Add fuel only in an area that has free movement of air and no open flames or sparks. **NO SMOKING!** [Figure 142].

Install and tighten the fuel fill cap (1) [Figure 142].

## WARNING

Always clean up spilled fuel or oil. Keep heat, flames, sparks or lighted tobacco away from fuel and oil. Failure to use care around combustibles can cause explosion or fire which can result in injury or death.

W-2103-1285

## FUEL SYSTEM (CONT'D)

### Fuel Filter

See your SERVICE SCHEDULE for the service interval for removing water from, or replacing the fuel filter. (See SERVICE SCHEDULE on Page 65.)

#### Removing Water

Figure 143

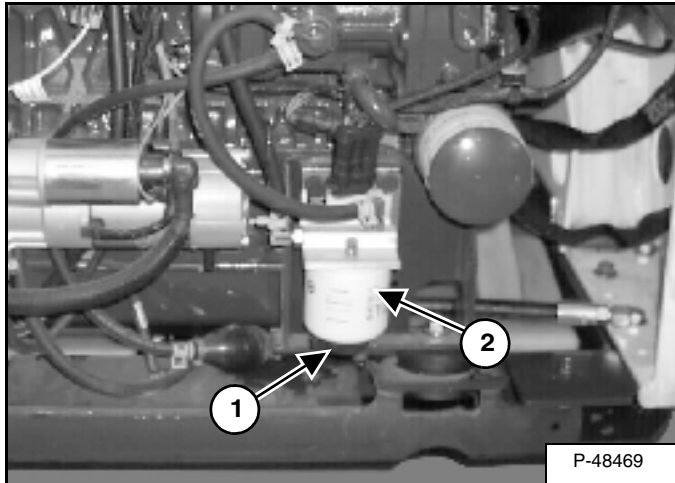

Loosen the drain (1) [Figure 143] at the bottom of the filter element to remove water from the filter.

#### Replacing Element

Remove the filter element (2) [Figure 143].

Clean the area around the filter housing. Put clean oil on the seal of the new filter element. Install the fuel filter, and hand tighten.

Remove the air from the fuel system. (See Below.)

## Removing Air From The Fuel System

After replacing the filter element or when the fuel tank has run out of fuel, the air must be removed from the fuel system before starting the engine.

# ! WARNING

Diesel fuel or hydraulic fluid under pressure can penetrate skin or eyes, causing serious injury or death. Fluid leaks under pressure may not be visible. Use a piece of cardboard or wood to find leaks. Do not use your bare hand. Wear safety goggles. If fluid enters skin or eyes, get immediate medical attention from a physician familiar with this injury.

W-2072-0496

Figure 144

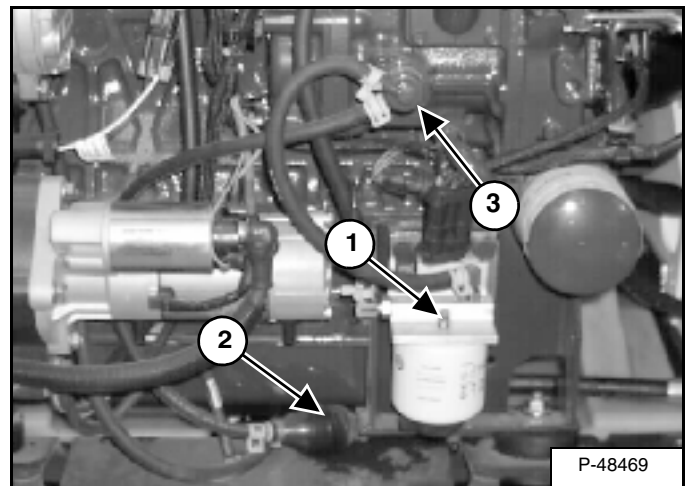

Open the vent (1) [Figure 144] on the fuel filter housing.

Squeeze the hand pump (priming bulb) (2) [Figure 144] until fuel flows from the vent with no air bubbles.

Close the vent (1) [Figure 144] on the fuel filter housing.

Open the vent (3) [Figure 144] on the fuel injection pump.

Squeeze the hand pump (priming bulb) (2) [Figure 144] until the pump feels solid.

Tighten the vent plug (3) [Figure 144].

Start the engine.

It may be necessary to open the vent plug (3) [Figure 144] briefly while the engine is running. Close the vent when the engine runs smoothly.

## ENGINE LUBRICATION SYSTEM

### Checking And Adding Engine Oil

Check the engine oil level every day before starting the engine for the work shift.

**Figure 145**

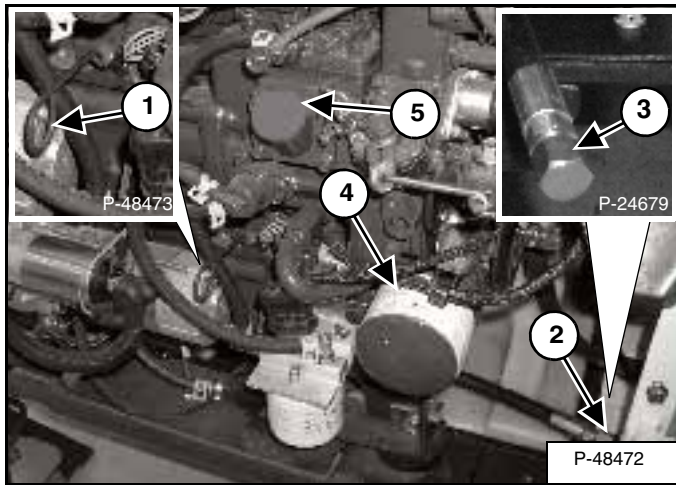

Park the machine on level ground. Open the rear door and remove the dipstick (1) [Figure 145].

Keep the oil level between the SAE marks on the dipstick. Do not overfill.

### Engine Oil Chart

**Figure 146**

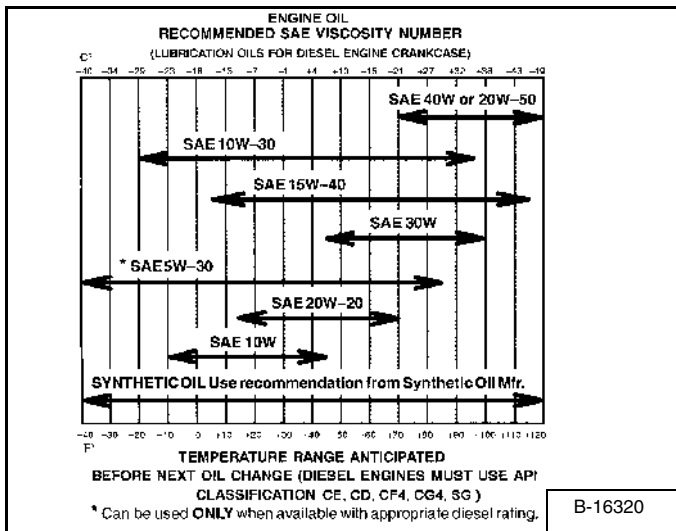

Use a good quality motor oil that meets API Service Classification of CD or better See Oil Chart [Figure 146].

Install the dipstick and close the rear door.

### Removing And Replacing Oil And Filter

See your SERVICE SCHEDULE for the service interval for replacing the engine oil and filter. (See SERVICE SCHEDULE on Page 65.)

Run the engine until it is at operating temperature. Stop the engine.

Open the rear door.

Remove the drain hose from the storage position (2) [Figure 145].

Remove the drain plug (3) [Figure 145].

Drain the oil into a container and dispose of used oil in an environmentally safe manner.

Remove the oil filter (4) [Figure 145].

Clean the filter housing surface.

Put clean oil on the new oil filter gasket.

Install the filter and hand tighten.

Install and tighten the drain plug.

Remove the fill cap (5) [Figure 145].

Put oil in the engine. (See Fluid Capacities on Page 122.) (Also See Oil Chart [Figure 146].) Do not overfill.

Start the engine and let it run for several minutes.

Stop the engine and check for leaks at the oil filter.

Remove the dipstick and check the oil level.

Add oil as needed if it is not at the top mark (1) on the dipstick.

Install the dipstick and close the rear door.



**Always clean up spilled fuel or oil. Keep heat, flames, sparks or lighted tobacco away from fuel and oil. Failure to use care around combustibles can cause explosion or fire which can result in injury or death.**

W-2103-1285

## ENGINE COOLING SYSTEM

Check the cooling system every day to prevent overheating, loss of performance or engine damage.

### Cleaning

Figure 147

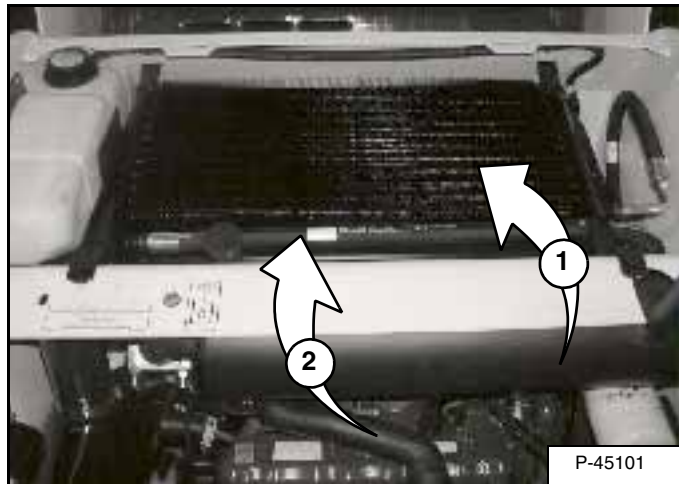

Open the rear door and raise the rear grill.

Use low air pressure or water pressure to clean the top of the oil cooler (1) [Figure 147].

**NOTE:** Be careful when raising and lowering the oil cooler so that the oil cooler does not fall on the radiator and damage the fins.

Raise the oil cooler and use low air pressure or water pressure to clean the top of the radiator (2) [Figure 148].

Lower the oil cooler.

Check cooling system for leaks.

Lower the rear grill and close the rear door.

## WARNING

### AVOID BURNS

Do not remove radiator cap when the engine is hot. You can be seriously burned.

W-2070-1203

### Checking Level

Open the rear door and raise the rear grill.

Figure 148

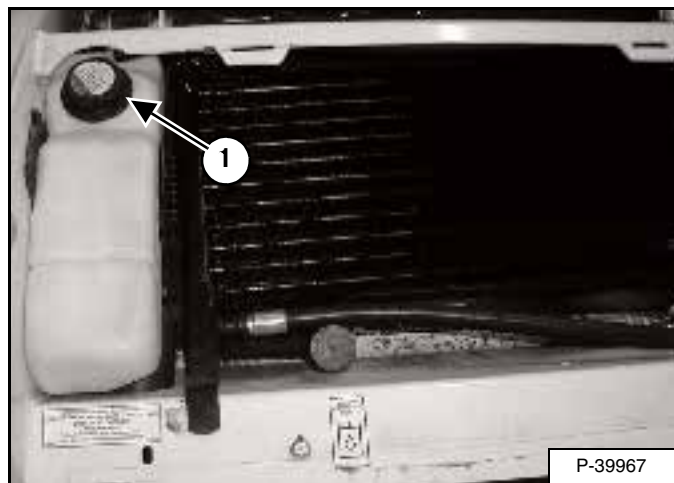

Remove the coolant fill cap (1) [Figure 148]. Check the coolant level. The level markers are inside the tank. Coolant must be at the bottom marker when the engine is cold; top marker when hot.

Close the rear door before operating the loader.

## IMPORTANT

### AVOID ENGINE DAMAGE

Always use the correct ratio of water to antifreeze.

Too much antifreeze reduces cooling system efficiency and may cause serious premature engine damage.

Too little antifreeze reduces the additives which protect the internal engine components; reduces the boiling point and freeze protection of the system.

Always add a premixed solution. Adding full strength concentrated coolant can cause serious premature engine damage.

I-2124-0497

## IMPORTANT

Wear safety glasses to prevent eye injury when any of the following conditions exist:

- When fluids are under pressure.
- Flying debris or loose material is present.
- Engine is running.
- Tools are being used.

W-2019-1285



## ENGINE COOLING SYSTEM (CONT'D)

### Removing And Replacing the Coolant

Open the rear door and remove the rear grill.

Figure 149

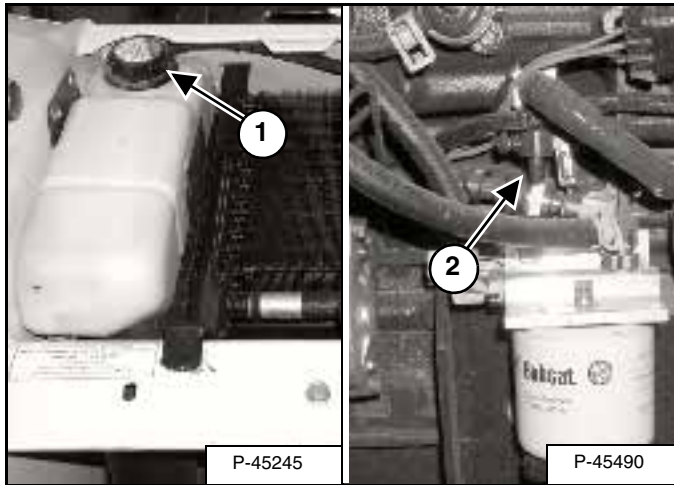

Remove the coolant fill cap (1) [Figure 149].

Connect a hose to the engine block drain valve (2) [Figure 149]. Open the drain valve and drain the coolant into a container.

After all the coolant is removed, close the drain valve and remove the hose.

Recycle or dispose of coolant in an environmentally safe manner.

Mix the coolant in a separate container. (See Fluid Capacities on Page 122.)

## WARNING

### AVOID BURNS

Do not remove radiator cap when the engine is hot. You can be seriously burned.

W-2070-1203

**NOTE: The loader is factory filled with propylene glycol coolant (purple color). DO NOT mix propylene glycol with ethylene glycol.**

Add premixed coolant, 47% water and 53% propylene glycol to the recovery tank. (See Checking Level on Page 82.)

4,3 L of propylene glycol mixed with 3,8 L of water is the correct mixture of coolant to provide a -37°C (-34°F) freeze protection.

Remove the coolant fill cap. Fill the tank until it is at the lower marker on the tank.

Use a refractometer to check the condition of propylene glycol in your cooling system.

Run the engine until it is at operating temperature. Stop the engine. Check the coolant level when cool. Add coolant as needed.

Install the rear grill and close the rear door.

## ELECTRICAL SYSTEM

### Description

Figure 150

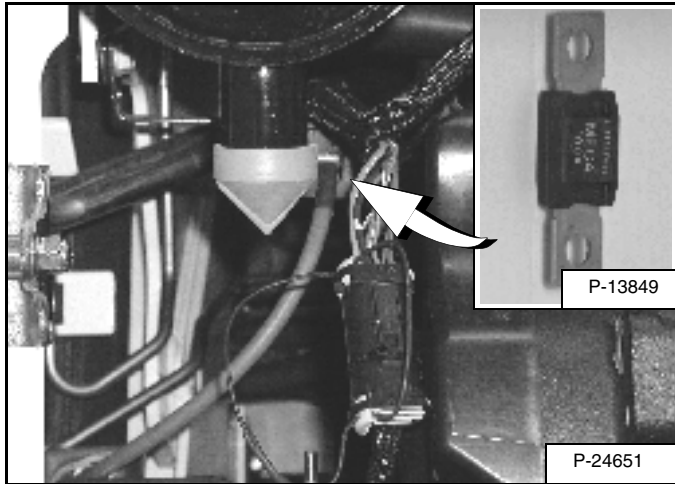

The loader has a 12 volt, negative ground alternator charging system. The electrical system is protected by fuses located in the cab on the steering control panel and a 100 amp. master fuse [Figure 150] in the engine compartment on the left side of the engine. The fuses will protect the electrical system when there is an electrical overload. The reason for the overload must be found before starting the engine again.

### Fuse And Relay Location / Identification

Figure 151

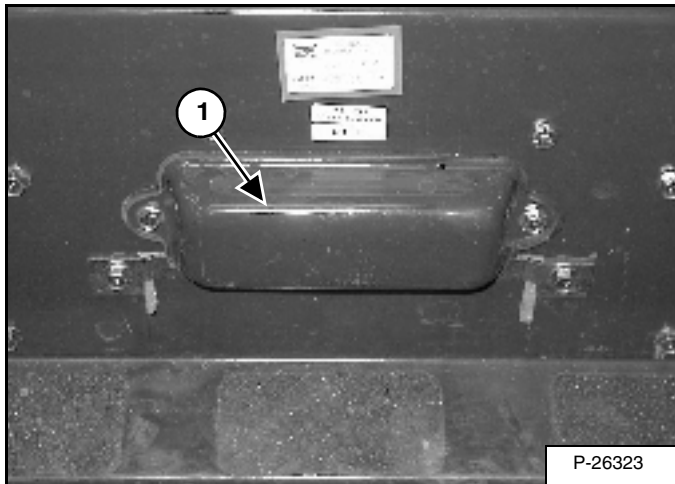

The electrical system is protected from overload by fuses and relays under the fuse panel cover (1) [Figure 151]. A decal is inside the cover to show location and amp ratings.

Remove the cover to check or replace the fuses.

Figure 152

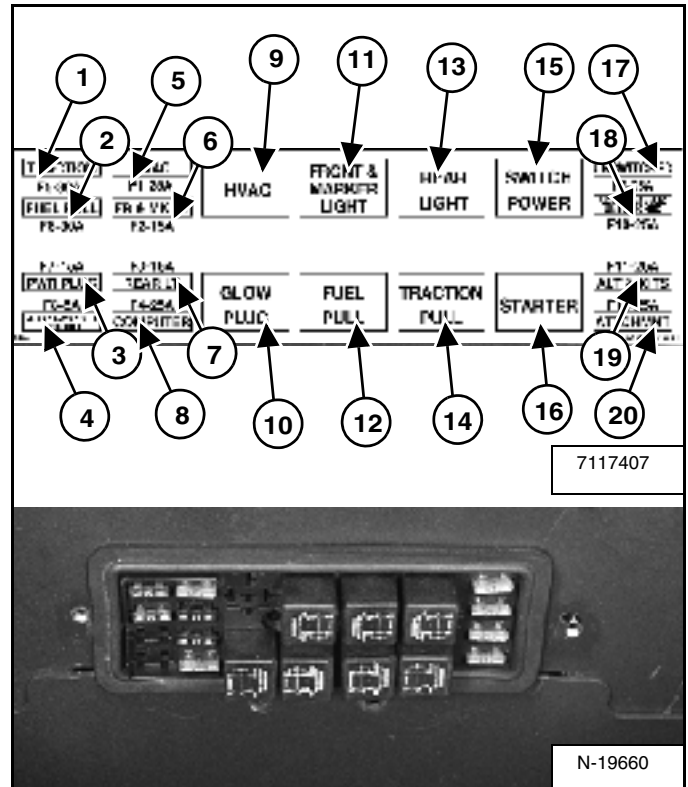

The location and sizes are shown below and in [Figure 152].

REF	DESCRIPTION	AMP	REF	DESCRIPTION	AMP
1	Traction	30	11	Front & Marker Lights	R
2	Fuel Shutoff	30	12	Fuel Shutoff	R
3	Power Plug	--	13	Rear Lights	R
4	ACS/AWS/SJC	--	14	Traction	R
5	Heater	25	15	Switch Power	R
6	Front & Marker Lights	15	16	Starter	R
7	Rear Lights	15	17	Unswitched Attach.	25
8	Bobcat Controller	25	18	Switched Attach.	25
9	Heater & Air Conditioning	--	19	Alternator & Accessories	25
10	Glow Plugs	R	20	Accessory Plug	25

R - Relay



## ELECTRICAL SYSTEM (CONT'D)

### Battery Maintenance

Figure 153

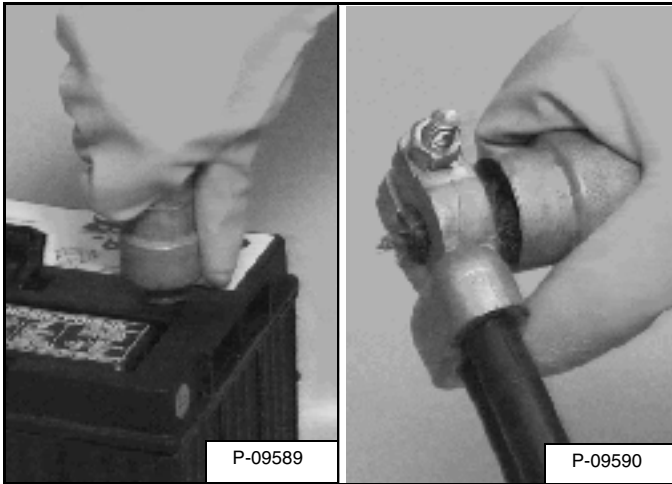

The battery cables must be clean and tight. Check the electrolyte level in the battery. Add distilled water as needed. Remove acid or corrosion from the battery and cables with a sodium bicarbonate and water solution [Figure 153].

Put Battery Saver (6664458) or grease on the battery terminals and cable ends to prevent corrosion.

## WARNING

Batteries contain acid which burns eyes and skin on contact. Wear goggles, protective clothing and rubber gloves to keep acid off body.

In case of acid contact, wash immediately with water. In case of eye contact get prompt medical attention and wash eye with clean, cool water for at least 15 minutes.

If electrolyte is taken internally drink large quantities of water or milk! DO NOT induce vomiting. Get prompt medical attention.

W-2065-1296

### Using A Booster Battery (Jump Starting)

If it is necessary to use a booster battery to start the engine, BE CAREFUL! There must be one person in the operator's seat and one person to connect and disconnect the battery cables.

The key switch must be OFF (*Key Switch Panel*) OR the STOP Button must be pressed (*Keyless Panel*). The booster battery must be 12 volts.

## WARNING

Keep arcs, sparks flames and lighted tobacco away from batteries. When *jumping* from booster battery make final connection (negative) at machine frame.

Do not jump start or charge a frozen or damaged battery. Warm battery to 16°C (60°F) before connecting to a charger. Unplug charger before connecting or disconnecting cables to battery. Never lean over battery while boosting, testing or charging.

Battery gas can explode and cause serious injury.

W-2066-0705

## ELECTRICAL SYSTEM (CONT'D)

### Using A Booster Battery (Jump Starting) (Cont'd)

Figure 154

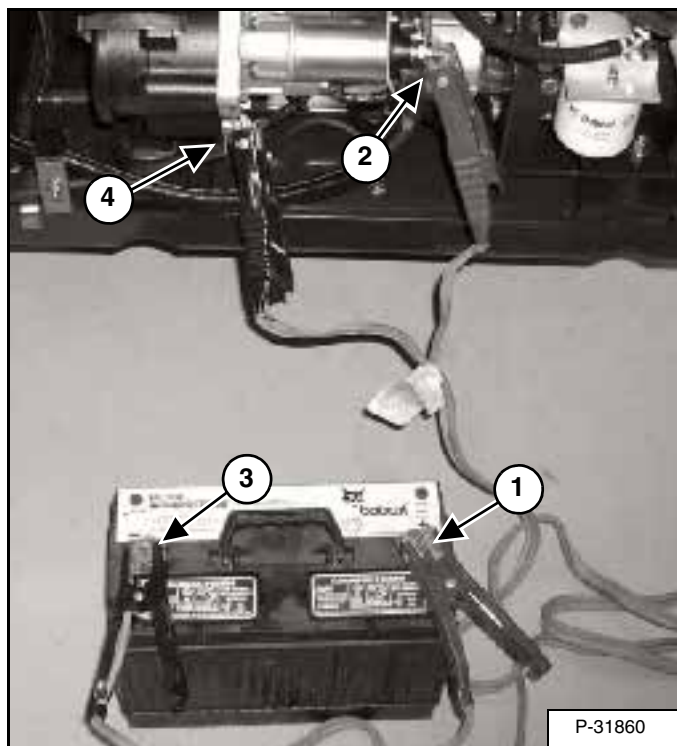

Connect the end of the first cable (1) [Figure 154] to the positive (+) terminal of the booster battery. Connect the other end of the same cable (2) [Figure 154] to the positive terminal on the loader starter.

Connect the end of the second cable (3) [Figure 154] to the negative (-) terminal of the booster battery. Connect the other end of the same cable (4) [Figure 154] to the engine.

Keep cables away from moving parts. Start the engine. (See STARTING THE ENGINE on Page 29.)

After the engine has started, remove the ground (-) cable (4) [Figure 154] first.

Remove the cable from the positive (+) terminal (2) [Figure 154].

# IMPORTANT

Damage to the alternator can occur if:

- Engine is operated with battery cables disconnected.
- Battery cables are connected when using a fast charger or when welding on the loader. (Remove both cables from the battery.)
- Extra battery cables (booster cables) are connected wrong.

I-2023-1285

## ELECTRICAL SYSTEM (CONT'D)

### Removing And Installing Battery

# WARNING

Batteries contain acid which burns eyes and skin on contact. Wear goggles, protective clothing and rubber gloves to keep acid off body.

In case of acid contact, wash immediately with water. In case of eye contact get prompt medical attention and wash eye with clean, cool water for at least 15 minutes.

If electrolyte is taken internally drink large quantities of water or milk! DO NOT induce vomiting. Get prompt medical attention.

W-2065-1296

Open the rear door.

Figure 155

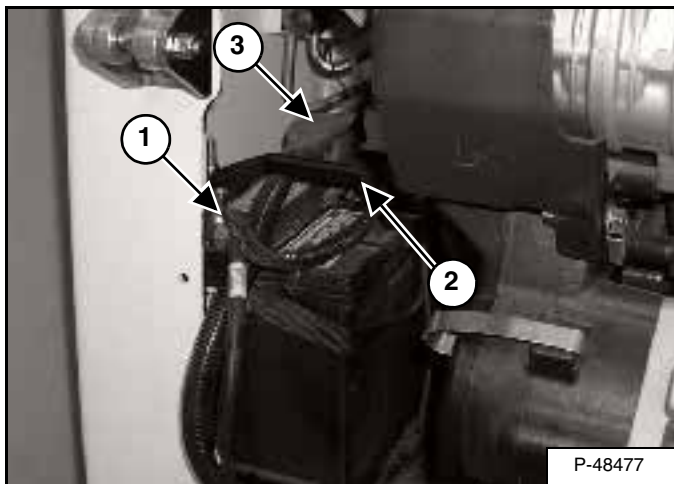

Disconnect the negative (-) battery cable (1) [Figure 155].

Remove the battery hold down clamp (2) [Figure 155].

Disconnect the positive (+) battery cable (3) [Figure 155].

Remove the battery from the loader.

Figure 156

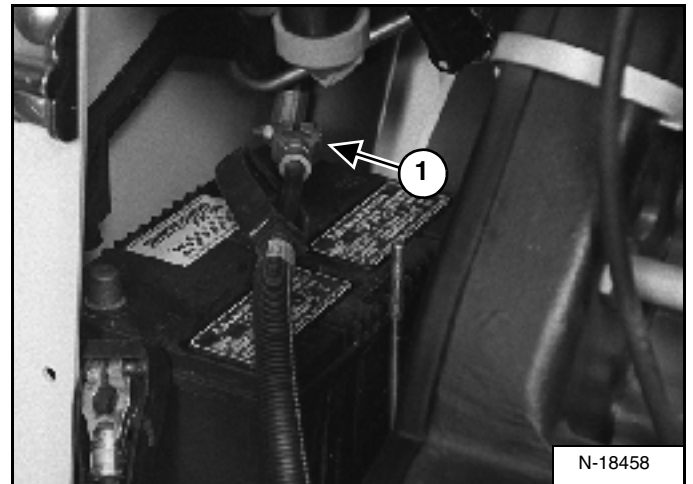

Disconnect the positive (+) battery cable (1) [Figure 156].

Remove the battery from the loader.

Figure 157

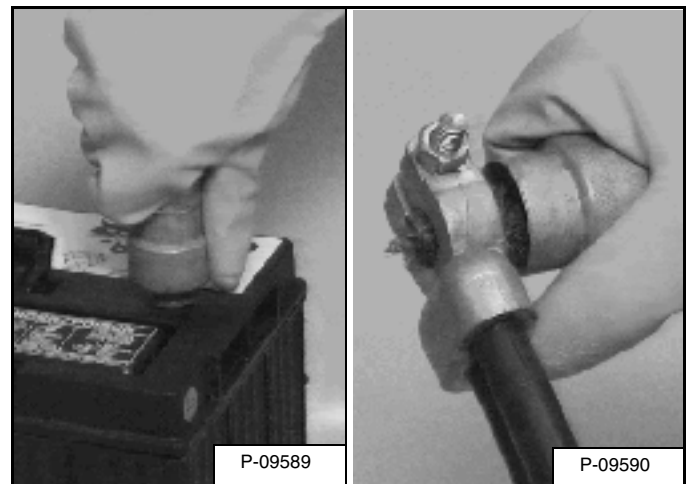

Always clean the battery terminals and cable ends when installing a new or used battery [Figure 157].

When installing the battery in the loader, do not touch any metal parts with the battery terminals.

Connect the negative (-) cable last to prevent sparks. Connect and tighten the battery cables.

Close the rear door before operating the loader.

## HYDRAULIC / HYDROSTATIC SYSTEM

### Checking And Adding Fluid

Use only recommended fluid in the hydraulic system. (See Hydraulic System on Page 121.)

Stop the loader on a level surface.

Lower the lift arms and tilt the Bob-Tach fully back.

Stop the engine.

**Figure 158**

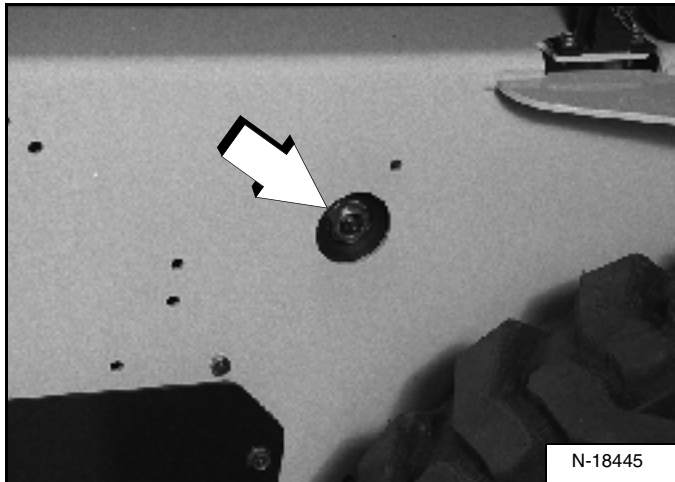

Check the fluid level in the sight gauge **[Figure 158]**.

Open the rear door and raise the rear grill.

**Figure 159**

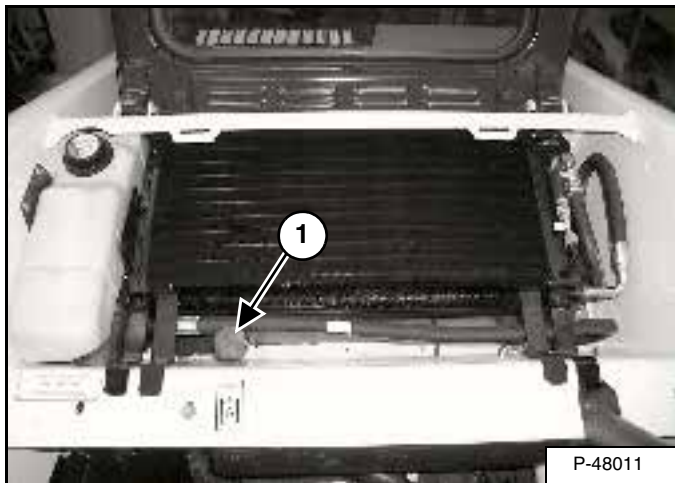

Remove the fill cap (1) **[Figure 159]**.

Add the fluid as needed to bring the level to the center of the sight gauge **[Figure 158]**.

Install the fill cap.

## Hydraulic / Hydrostatic Fluid Chart

**Figure 160**

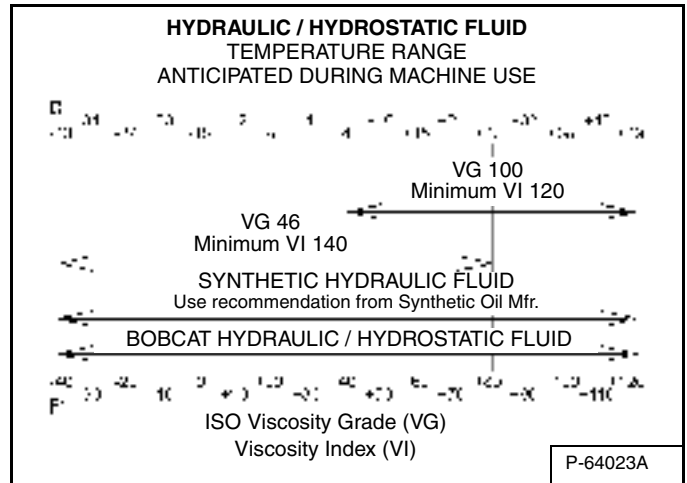

Use the correct hydraulic / hydrostatic fluid shown in chart **[Figure 160]**.

### Removing And Replacing Hydraulic / Hydrostatic Filter

See your SERVICE SCHEDULE for the correct service intervals. (See SERVICE SCHEDULE on Page 65.)

Open the rear door.

**Figure 161**

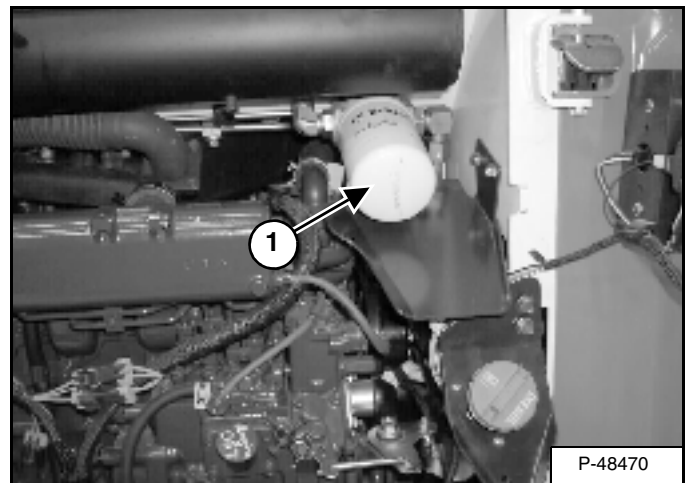

Remove the filter element (1) **[Figure 161]**.

Clean the surface of the filter housing where the seal contacts the housing.

Put clean oil on the seal of the new filter element.

Install and hand tighten the filter element.

Close the rear door before operating the loader.

## HYDRAULIC / HYDROSTATIC SYSTEM (CONT'D)

### Removing And Replacing Hydraulic Fluid And Case Drain Filters

See your SERVICE SCHEDULE for the service interval. (See SERVICE SCHEDULE on Page 65.)

The fluid must be replaced if it becomes contaminated or after major repairs. If the fluid is replaced, the hydrostatic filter and both case drain filters must be replaced.

Figure 162

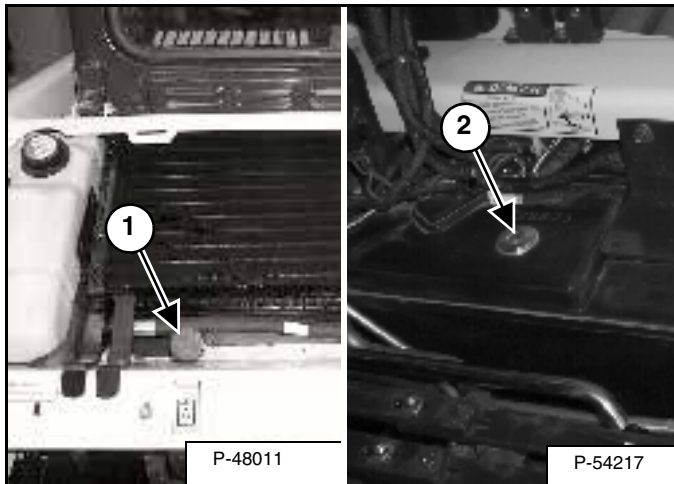

Raise the cab (See Raising on Page 71).

Open the rear door, remove the rear grill and remove the reservoir fill cap (1) [Figure 162].

Remove the plug (2) [Figure 162] and use a pump to remove the oil from the reservoir. Install the plug again.

Figure 163

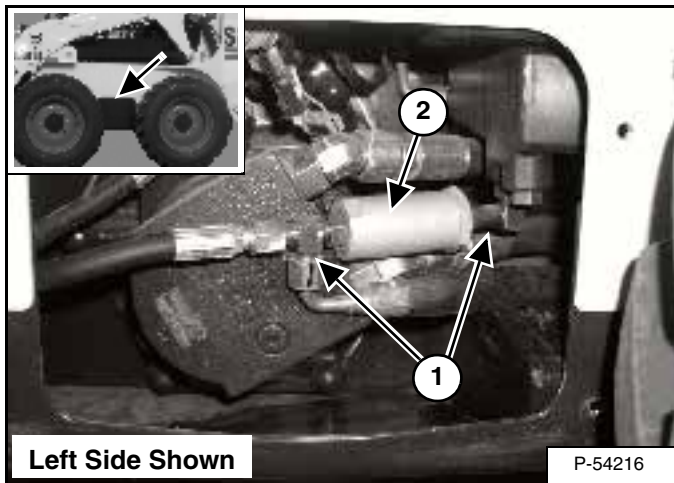

Remove the motor access covers (Inset) [Figure 163] from both sides of the loader.

Disconnect the fittings (1) [Figure 163] and remove the case drain filter (2) [Figure 163]. Use a plug and cap to prevent leakage.

Figure 164

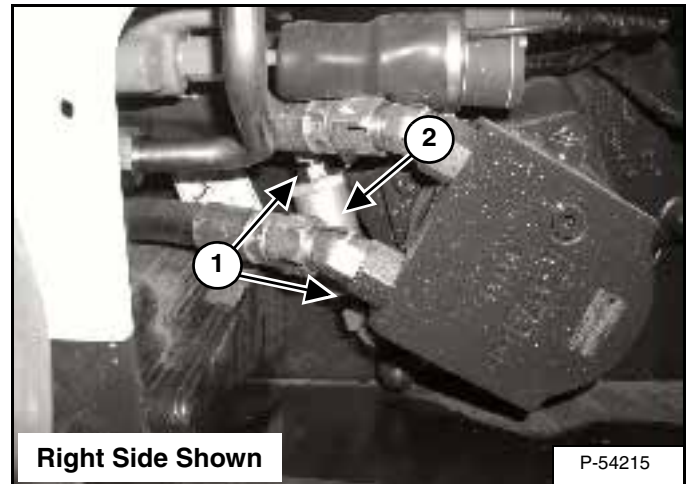

Disconnect the fittings (1) [Figure 164] and remove the case drain filter (2) [Figure 164]. Use a plug and cap to prevent leakage.

Replace the hydraulic / hydrostatic filter element. (See HYDRAULIC / HYDROSTATIC SYSTEM on Page 88.)

Replace both hydrostatic motor case drain filters (2) [Figure 163] and [Figure 164].

Add the correct fluid to the reservoir until the fluid level is at the center of the sight gauge (Do not overfill).



Hydraulic fluid escaping under pressure can have sufficient force to enter a person's body by penetrating the skin. This can cause serious injury and possible death if proper medical treatment by a physician familiar with this injury is not received immediately.

W-2145-0290

Install the rear grill and close the rear door.

Lower the cab (See Lowering on Page 72).



## HYDRAULIC / HYDROSTATIC SYSTEM (CONT'D)

### Removing And Replacing Hydraulic Fluid And Case Drain Filters (Cont'd)

# WARNING

Always clean up spilled fuel or oil. Keep heat, flames, sparks or lighted tobacco away from fuel and oil. Failure to use care around combustibles can cause explosion or fire which can result in injury or death.

W-2103-1285

Start the engine and operate the loader hydraulic controls. Stop the engine and check for leaks.

Check the fluid level in the reservoir and add as needed.

### Removing And Replacing Charge Filter

The charge filter is located under the cab.

Raise the cab (See Raising on Page 71).

Figure 165

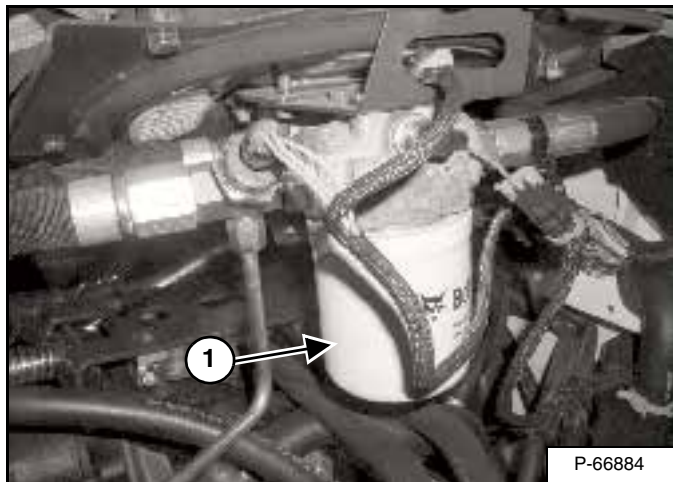

Remove the filter (1) [Figure 165].

Clean the surface of the filter housing where the filter seal contacts the housing.

Put clean oil on the seal of the new filter. Install and hand tighten the new filter.

# WARNING

Diesel fuel or hydraulic fluid under pressure can penetrate skin or eyes, causing serious injury or death. Fluid leaks under pressure may not be visible. Use a piece of cardboard or wood to find leaks. Do not use your bare hand. Wear safety goggles. If fluid enters skin or eyes, get immediate medical attention from a physician familiar with this injury.

W-2072-0496

Start the engine and operate the loader hydraulic controls.

Stop the engine and check for leaks at the filter.

Check the fluid level in the reservoir and add as needed.

## HYDRAULIC / HYDROSTATIC SYSTEM (CONT'D)

### Removing And Replacing Charge Filter (Cont'd)

# WARNING

Always clean up spilled fuel or oil. Keep heat, flames, sparks or lighted tobacco away from fuel and oil. Failure to use care around combustibles can cause explosion or fire which can result in injury or death.

W-2103-1285

Lower the cab. (See Lowering on Page 72.)

### Breather Cap

See your SERVICE SCHEDULE for the correct replacement interval. (See SERVICE SCHEDULE on Page 65.)

Raise the cab. (See Raising on Page 71.)

Figure 166

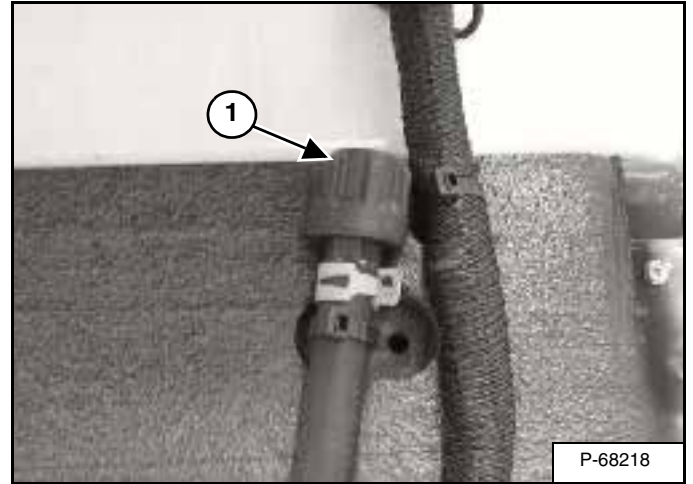

Remove the breather cap (1) [Figure 166] and discard.

Install new cap.

Lower the cab. (See Lowering on Page 72.)

## SPARK ARRESTOR MUFFLER

### Cleaning Procedure

See your SERVICE SCHEDULE for service the interval for cleaning the spark arrestor muffler. (See SERVICE SCHEDULE on Page 65.)

Do not operate the loader with a defective exhaust system.

## IMPORTANT

This loader is factory equipped with a spark arrestor muffler. It is necessary to do maintenance on this spark arrestor muffler to keep it in working condition. The spark arrestor muffler must be serviced by dumping the spark chamber every 100 hours of operation.

If this machine is operated on flammable forest, brush or grass covered land, it must be equipped with a spark arrestor attached to the exhaust system and maintained in working order.

Make reference to local laws and regulations for spark arrestor requirements.

I-2022-0595

Stop the engine. Open the rear door and raise the rear grill.

Figure 167

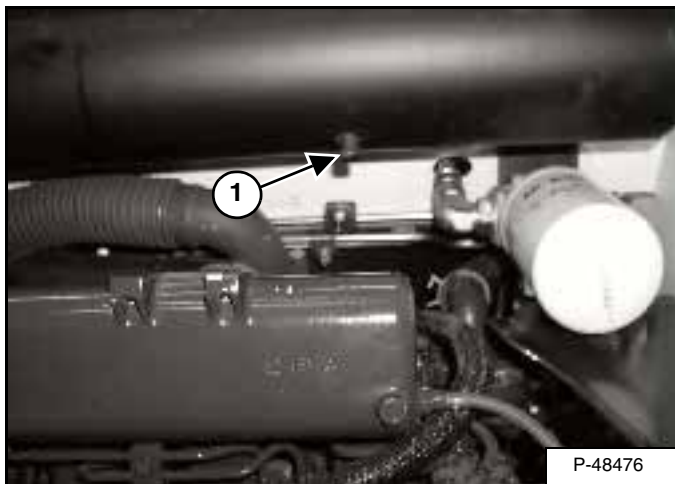

Remove the plug (1) [Figure 167] from the bottom of the muffler.

## ! WARNING

When the engine is running during service, the steering levers must be in neutral and the parking brake engaged. Failure to do so can cause injury or death.

W-2006-0284

Start the engine and run for about 10 seconds while a second person, wearing safety glasses, holds a piece of wood over the outlet of the muffler.

This will force contaminants out through the cleanout hole.

Stop the engine.

Install and tighten the plug.

Lower the rear grill and close the rear door.

## ! WARNING

When an engine is running in an enclosed area, fresh air must be added to avoid concentration of exhaust fumes. If the engine is stationary, vent the exhaust outside. Exhaust fumes contain odorless, invisible gases which can kill without warning.

W-2050-1285

## ! WARNING

Stop engine and allow the muffler to cool before cleaning the spark chamber. Wear safety goggles. Failure to obey can cause serious injury.

W-2011-1285

## ! WARNING

Never use machine in atmosphere with explosive dust or gases or where exhaust can contact flammable material. Failure to obey warnings can cause injury or death.

W-2068-1285



## TIRE MAINTENANCE

### Wheel Nuts

Figure 168



See your SERVICE SCHEDULE for the service interval to check the wheel nuts [Figure 168]. (See SERVICE SCHEDULE on Page 65.)

When *installing* wheel nuts, tighten to 217 Nm torque.

When *checking* wheel nut torque, set the torque wrench to 190 Nm to prevent over-tightening.

### Rotating

Check the tires regularly for wear, damage and pressure. Inflate tires to the maximum pressure shown on the sidewall of the tire.

Figure 169

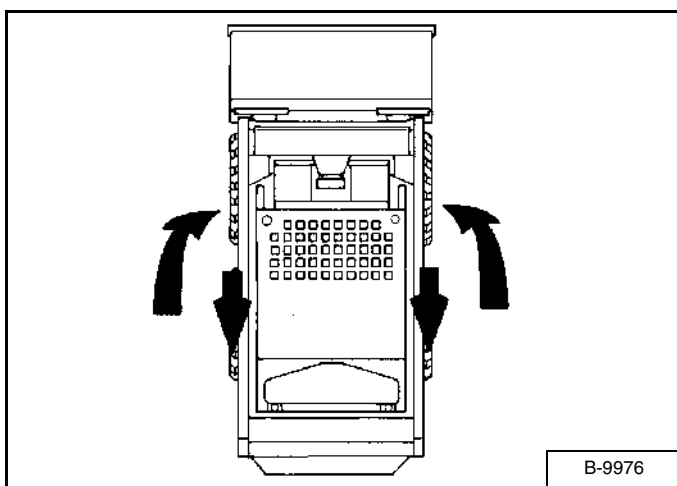

Rear tires usually wear faster than front tires. To keep tire wear even, move the front tires to the rear and rear tires to the front [Figure 169].

It is important to keep the same size tires on each side of the loader. If different sizes are used, each tire will be turning at a different rate and cause excessive wear. The tread bars of all the tires must face the same direction.

Recommended tire pressure must be maintained to avoid excessive tire wear and loss of stability and handling capability. Check for the correct pressure before operating the loader.

### Mounting

Tires are to be repaired only by an authorized person using the proper procedures and safety equipment.

Tires and rims must always be checked for correct size before mounting. Check rim and tire bead for damage.

The rim flange must be cleaned and free of rust.

The tire bead and rim flange must be lubricated with a rubber lubricant before mounting the tire.

Avoid excessive pressure which can rupture the tire and cause serious injury or death.

During inflation of the tire, check the tire pressure frequently to avoid over inflation.

## **WARNING**

**Do not inflate tires above specified pressure. Failure to use correct tire mounting procedure can cause an explosion which can result in injury or death.**

W-2078-1285

## **IMPORTANT**

**Inflate tires to the MAXIMUM pressure shown on the sidewall of the tire. DO NOT mix brands of tires used on the same loader.**

I-2057-0794

## FINAL DRIVE TRANSMISSION (CHAINCASE)

### Checking And Adding Oil

The chaincase contains the final drive sprockets and chains. Use the same type of oil as the hydraulic / hydrostatic system. (See (S205) LOADER SPECIFICATIONS on Page 119.)

Stop the loader on a level surface.

Stop the engine.

**Figure 170**

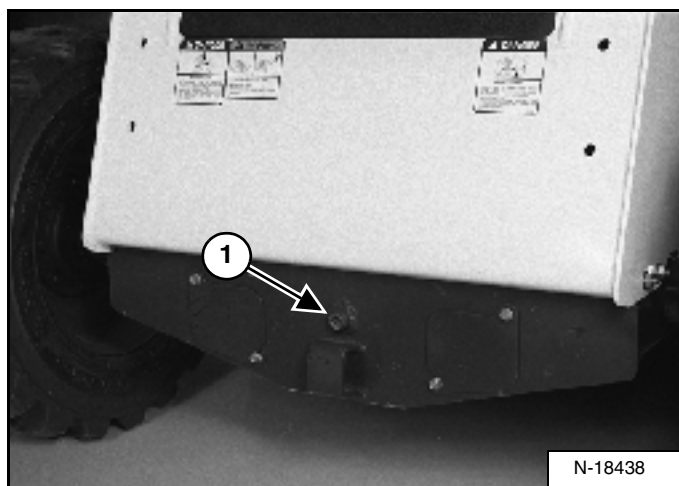

Remove the plug (1) [Figure 170] from the front of the chaincase housing.

If oil can be reached with the tip of your finger through the hole, the oil level is correct.

If the level is low, add oil through the check plug hole until the oil flows from the hole.

Install and tighten the plug.

### Removing Oil From The Chaincase

Remove the check plug (1) [Figure 170] from the front of the chaincase housing.

**Figure 171**



Remove the oil from the chaincase [Figure 171].

Recycle or dispose of the used oil in an environmentally safe manner.

## ALTERNATOR BELT

### Belt Adjustment

Stop the engine.

Raise the operator cab. (See Raising on Page 71.)

Figure 172

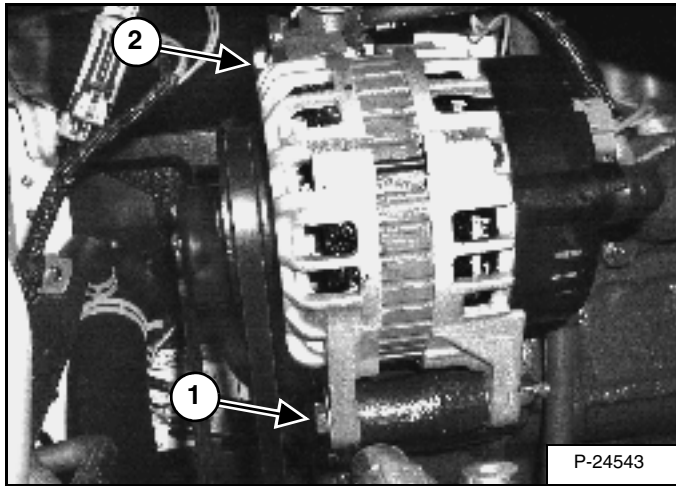

Loosen the alternator mounting bolt (1) [Figure 172].

Loosen the adjustment bolt (2) [Figure 172].

Move the alternator until the belt has 8,0 mm movement at the middle of the belt span with 66 N of force.

Tighten the adjustment bolt and mounting bolt.

Lower the operator cab. (See Lowering on Page 72.)

### Belt Replacement

Loosen the alternator mounting and adjustment bolts (1 and 2) [Figure 172] and loosen the belt all the way.

Remove the belt and install a new belt.

Adjust the belt as shown above.

## AIR CONDITIONING BELT

### Belt Adjustment

Figure 173

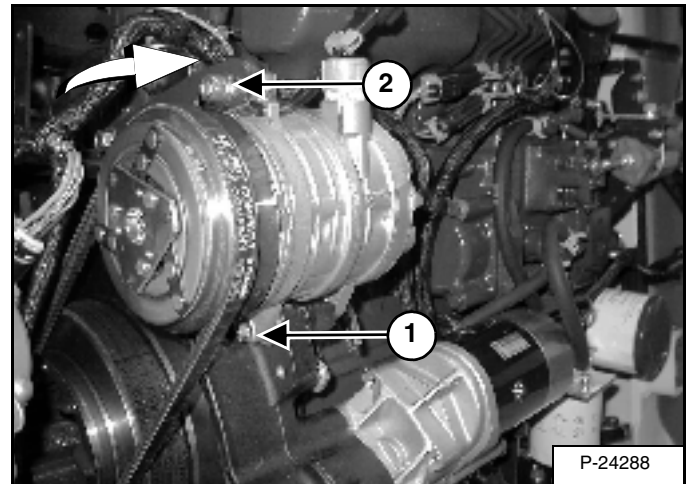

Inspect the drive belt regularly for wear. (See SERVICE SCHEDULE on Page 65.)

Open the rear door. Remove the drive belt cover. Remove the compressor belt cover.

Loosen the mounting bolt (1) and the adjustment bolt (2) [Figure 173].

Move the compressor to the rear until the belt has 8,0 mm movement at the middle of the belt span with 66 N force.

Tighten the adjustment bolt and the mounting bolt.

Install the covers and close the rear door.

### Belt Replacement

Open the rear door. Remove the drive belt cover and the compressor belt cover.

Loosen the mounting bolt (1) and the adjustment bolt (2) [Figure 173] and move the compressor all the way forward.

Remove the belt and install a new belt.

Adjust the belt as shown above.

## DRIVE BELT

### Belt Adjustment

Stop the engine.

Open the rear door and disconnect the negative (-) cable from the battery.

Remove three belt shield fasteners and remove the belt shield.

Figure 174

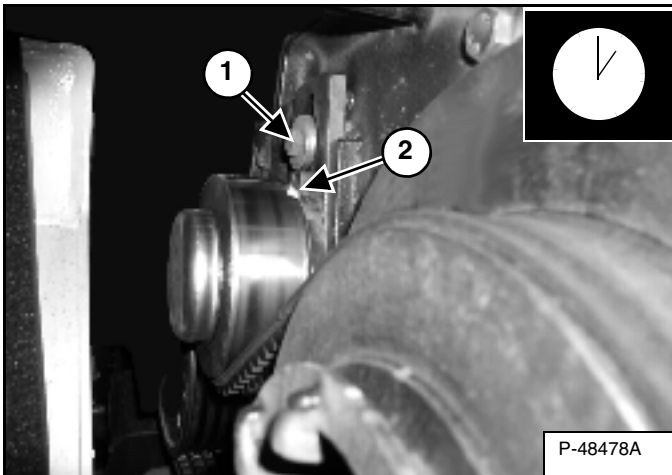

Loosen the bolt (1) [Figure 174] on the spring loaded drive idler.

**NOTE:** The pointer will be at the 1 o'clock position (2) [Figure 174] when the belt tensioner is not under spring tension.

Figure 175

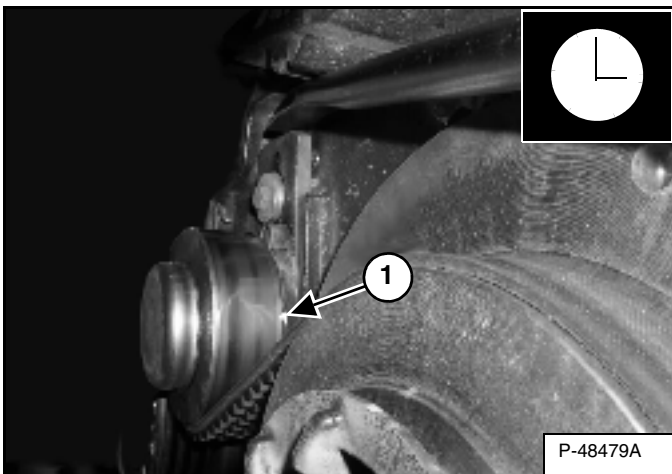

Push the idler pulley against the belt, using a pry bar [Figure 175]. The pointer will be at the 3 o'clock position (1) [Figure 175] when the idler pulley is against the stop (maximum movement).

Raise the idler assembly slightly so that the pulley is operating on spring tension and not against the stop.

**NOTE:** Do not set the idler against the travel stop in the 3 o'clock position.

Tighten the mounting bolt (1) [Figure 174] to 34-38 Nm torque.

Run the engine for a few minutes. Stop the engine and recheck the pointer position.

Readjust if necessary.

After the idler has been in service, readjust when the pointer reaches the 1 o'clock position.

Install the belt shield and fasteners.

Connect the negative (-) battery cable.

Close the rear door.

### Belt Replacement

Follow the steps above to loosen the drive belt tensioner.

Remove the bolt (1) [Figure 174] from the tensioner and remove the tensioner assembly.

Remove the fan drive belt.

Remove the drive belt from the pump pulley and flywheel and remove the belt from the loader.

Install the new drive belt. Install the belt tensioner assembly.

Install the fan drive belt.

Adjust the drive belt, reinstall previously removed components and continue procedure from *Belt Adjustment* above.

## LUBRICATING THE LOADER

### Lubrication Locations

Lubricate the loader as specified for the best performance of the loader. (See SERVICE SCHEDULE on Page 65.)

Record the operating hours each time you lubricate the Bobcat Loader.

Always use a good quality lithium based multi-purpose grease when you lubricate the loader. Apply lubricant until extra grease shows.

Lubricate the following locations on the loader:

**Figure 176**

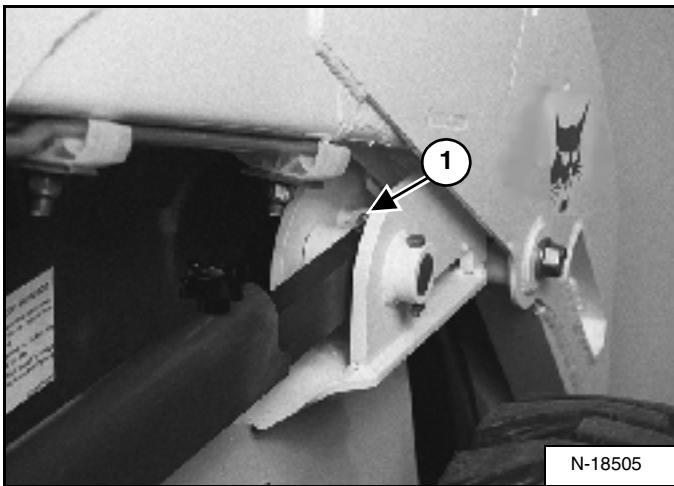

1. Stabilizer Rod - Front (Both Sides) [Figure 176].

**Figure 177**

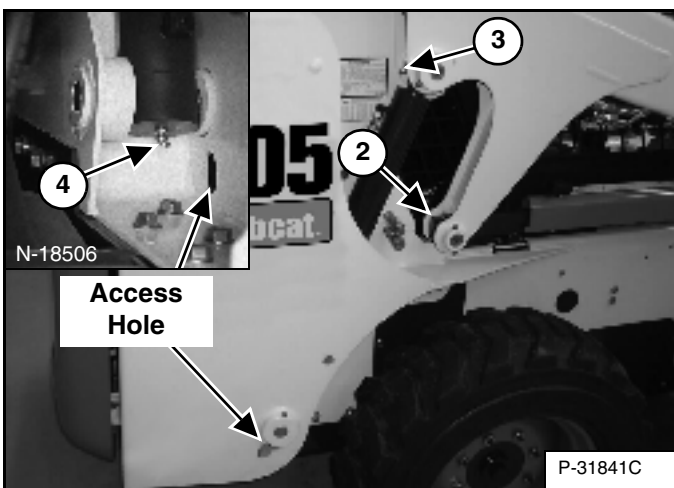

2. Stabilizer Rod - Rear (Both Sides) [Figure 177].
3. Lift Cylinder Rod End (Both Sides) [Figure 177].
4. Lift Cylinder Base End (Both Sides) [Figure 177].

**Figure 178**

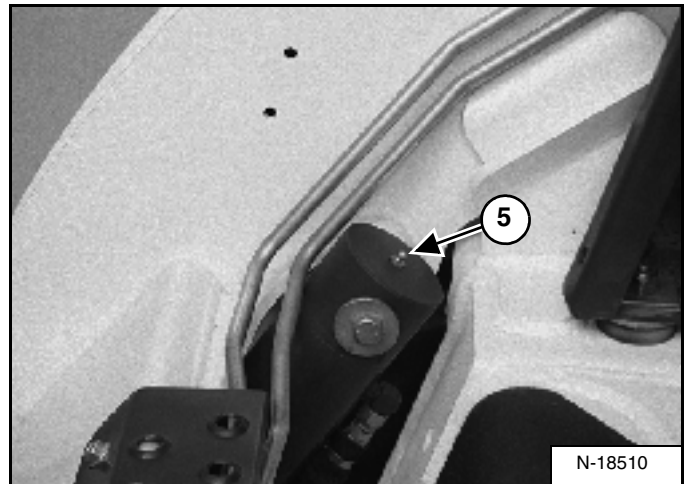

5. Tilt Cylinder Base End (Both Sides) [Figure 178].

**Figure 179**

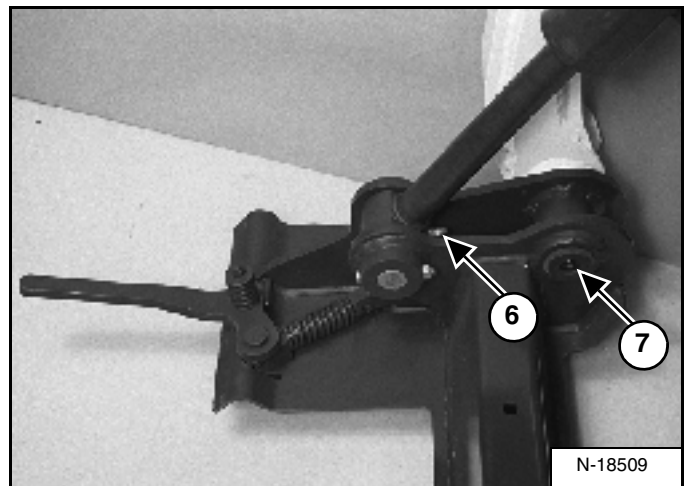

6. Tilt Cylinder Rod End (Both Sides) [Figure 179].
7. Bob-Tach Pivot Pin (Both Sides) [Figure 179].

## LUBRICATING THE LOADER (CONT'D)

### Lubrication Locations (Cont'd)

Figure 180

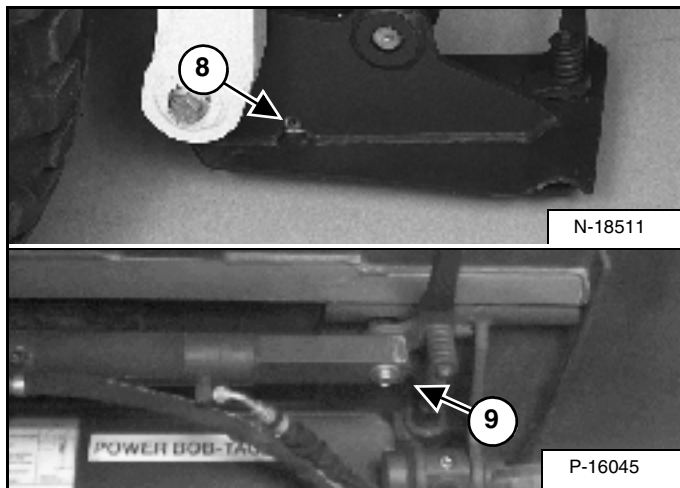

8. Bob-Tach Wedge (Both Sides) [Figure 180].

9. Power Bob-Tach Cylinder (Both Sides) [Figure 180].

Figure 181

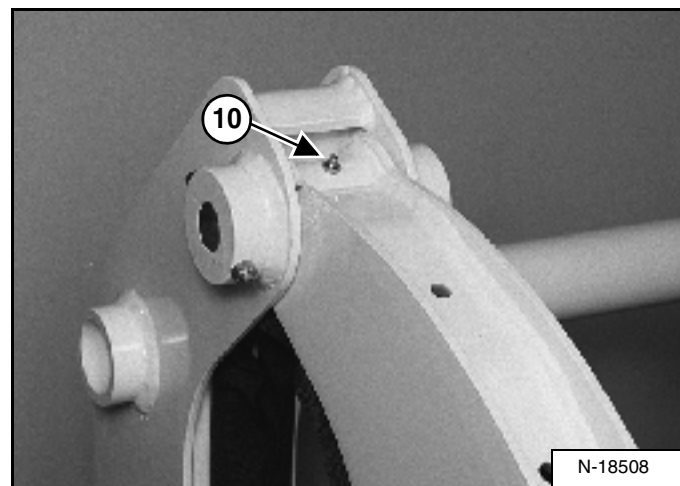

10. Lift Arm Pivot Pin (Both Sides) [Figure 181].

Figure 182

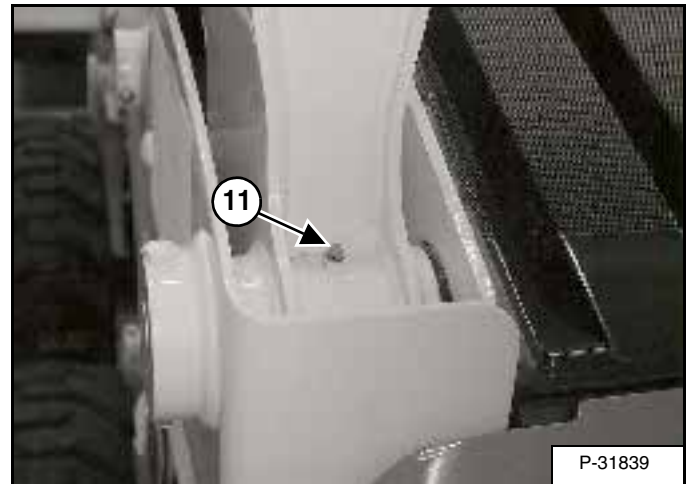

11. Lift Arm Link Pivot Pin (Both Sides) [Figure 182].

Figure 183

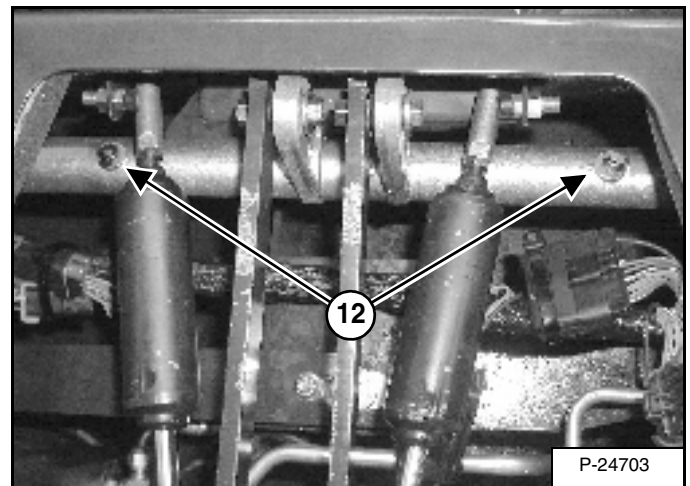

12. 250 Hours: Steering Lever Shaft (2) [Figure 183].

## PIVOT PINS

### Inspection And Maintenance

Figure 184

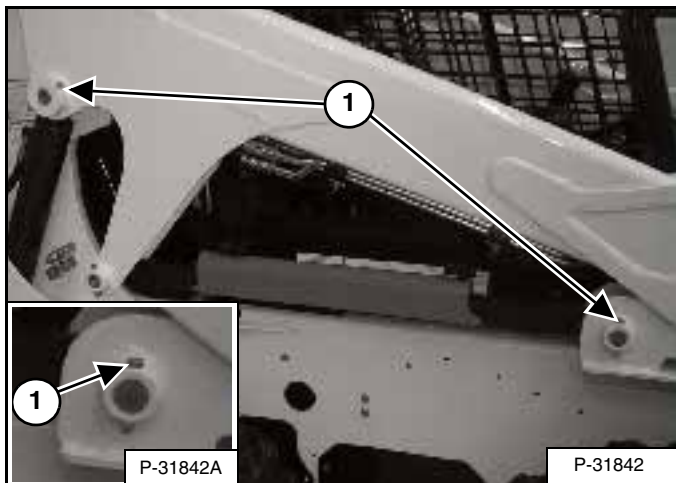

All lift arm and cylinder pivots have a large pin held in position with a retainer bolt and lock nut (1) [Figure 184].

Check that the lock nuts are tightened to 34-38 Nm torque.



## BOB-TACH (HAND LEVER)

### Inspection And Maintenance

Figure 185

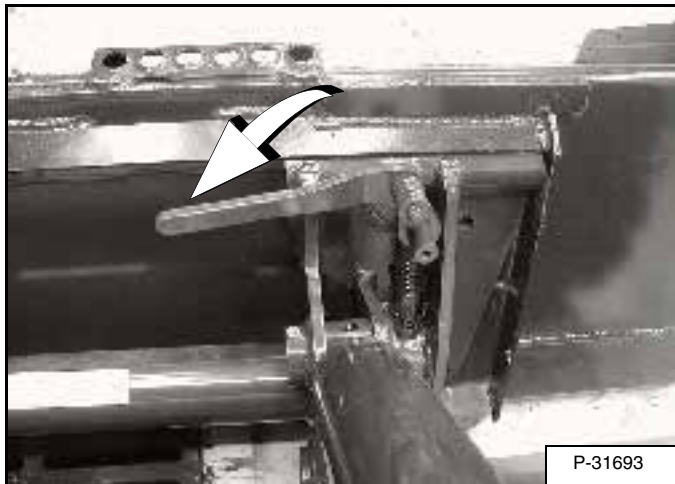

Move the Bob-Tach levers down to engage the wedges [Figure 185].

The levers and wedges must move freely.

## **WARNING**

Bob-Tach wedges must extend through the holes in attachment. Levers must be fully down and locked. Failure to secure wedges can allow attachment to come off and cause injury or death.

W-2102-0588

Figure 186

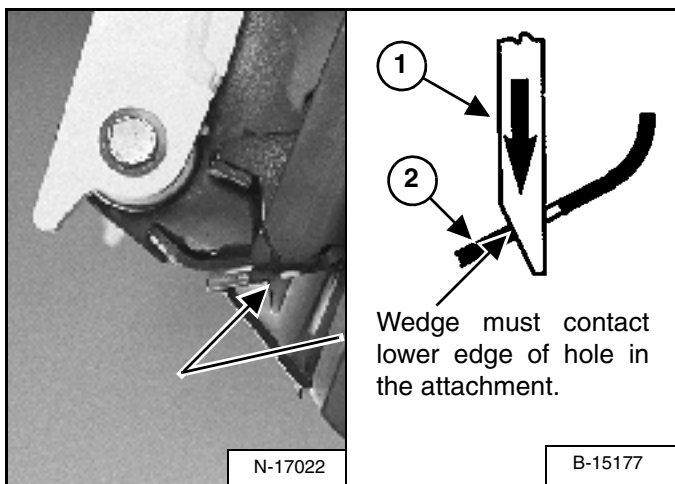

The wedges (1) must extend through the holes in the attachment mounting frame (2) [Figure 186].

The spring loaded wedge (1) [Figure 186] must contact the lower edge of the hole in the attachment (2) [Figure 186].

If the wedge does not contact the lower edge of the hole [Figure 186], the attachment will be loose and can come off the Bob-Tach.

Figure 187

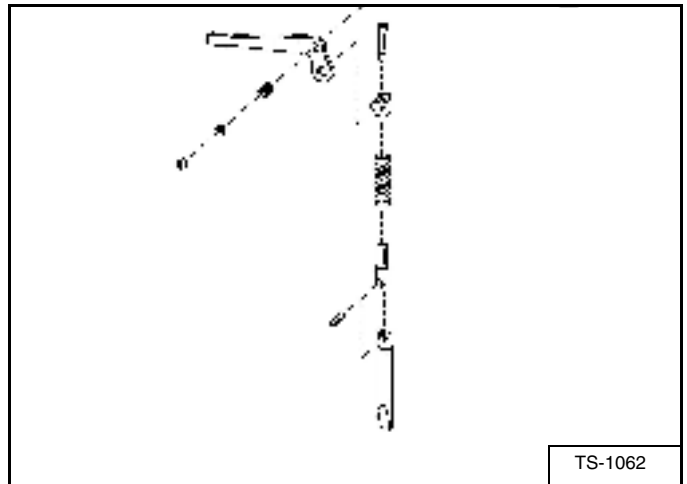

Inspect the mounting frame on the attachment and the Bob-Tach, linkages and wedges for excessive wear or damage [Figure 187]. Replace any parts that are damaged, bent, or missing. Keep all fasteners tight.

Look for cracked welds. Contact your Bobcat dealer for repair or replacement parts.

Lubricate the wedges. (See SERVICE SCHEDULE on Page 65). (See LUBRICATING THE LOADER on Page 97).



## BOB-TACH (POWER - OPTION)

### Inspection And Maintenance

Figure 188

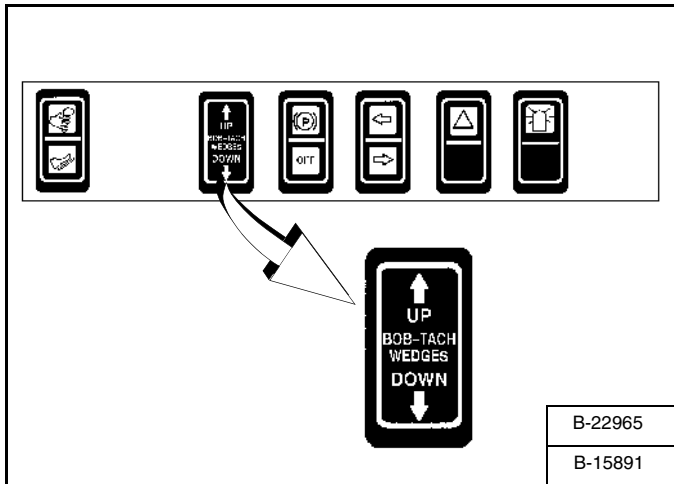

Push and hold the BOB-TACH “WEDGES UP” switch [Figure 188] until wedges are fully raised. Push and hold the BOB-TACH “WEDGES DOWN” switch [Figure 188] until the wedges are fully down.

The levers and wedges must move freely.



Bob-Tach wedges must extend through the holes in attachment. Levers must be fully down and locked. Failure to secure wedges can allow attachment to come off and cause injury or death.

W-2102-0588

Figure 189

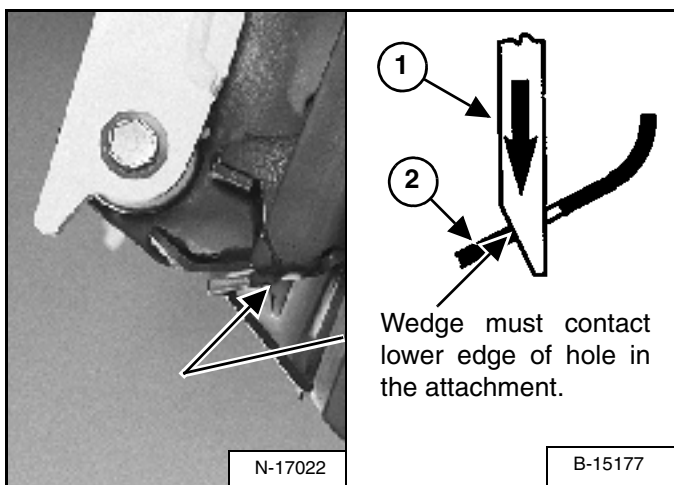

The wedges (1) must extend through the holes in the attachment mounting frame (2) [Figure 189].

The spring loaded wedge (1) [Figure 189] must contact the lower edge of the hole in the attachment (2) [Figure 189].

If the wedge does not contact the lower edge of the hole [Figure 189], the attachment will be loose and can come off the Bob-Tach.

Figure 190



Inspect the mounting frame on the attachment and the Bob-Tach, linkages and wedges for excessive wear or damage [Figure 190]. Replace any parts that are damaged, bent, or missing. Keep all fasteners tight.

Look for cracked welds. Contact your Bobcat dealer for repair or replacement parts.

Lubricate the wedges (See SERVICE SCHEDULE on Page 65). (See LUBRICATING THE LOADER on Page 97).

## LOADER STORAGE AND RETURN TO SERVICE

### Storage

Sometimes it may be necessary to store your Bobcat Loader for an extend period of time. Below is a list of items to perform before storage.

- Thoroughly clean the loader including the engine compartment.
- Lubricate the loader.
- Replace worn or damaged parts.
- Park the loader in a dry protected shelter.
- Lower the lift arms all the way and put the bucket flat on the ground.
- Put blocks under the frame to remove weight from the tires.
- Put grease on any exposed cylinder rods.
- Put fuel stabilizer in the fuel tank and run the engine a few minutes to circulate the stabilizer to the pump and fuel injectors.
- Drain and flush the cooling system. Refill with premixed coolant.
- Replace all fluids and filters (engine, hyd. / hydro.).
- Replace air cleaner, heater and air conditioning filters.
- Put all controls in neutral position.
- Remove the battery. Be sure the electrolyte level is correct then charge the battery. Store it in a cool dry place above freezing temperatures and charge it periodically during storage.
- Cover the exhaust pipe opening.
- Tag the machine to indicate that it is in storage condition.

### Return to Service

After the Bobcat Loader has been in storage, it is necessary to follow a list of items to return the loader to service.

- Check the engine and hydraulic oil levels; check coolant level.
- Install a fully charged battery.
- Remove grease from exposed cylinder rods.
- Check all belt tensions.
- Be sure all shields and guards are in place.
- Lubricate the loader.
- Check tire inflation and remove blocks from under frame.
- Remove cover from exhaust pipe opening.
- Start the engine and let run for a few minutes while observing the instrument panels and systems for correct operation.
- Operate machine, check for correct function.
- Stop the engine and check for leaks. Repair as needed.

## SYSTEM SETUP & ANALYSIS

BOBCAT INTERLOCK CONTROL SYSTEM (BICS) .....	105
Troubleshooting.....	105
DIAGNOSTIC SERVICE CODES .....	106
Service Codes List.....	106
DISPLAY CONTROLLER PANEL SETUP .....	111
Panel Setup.....	112
Panel Upgrade .....	111
Passwords.....	112
Viewing Service Codes (Key Switch) .....	114
Viewing Service Codes (Keyless) .....	114
SHUTDOWN FEATURE .....	115
Procedure .....	115

**SYSTEM SETUP  
& ANALYSIS**







**Bobcat®**

# BOBCAT INTERLOCK CONTROL SYSTEM (BICS)

## Troubleshooting

The following list shows the effects which can happen to the loader, and the probable causes when the BICS System lights are off or flashing and associated service code.

Indicator Light	Light ON	Light OFF	Effect on Operation of Loader When Light is OFF	SERVICE CODES Means System Error (See Your Bobcat Dealer For Service)		
				No. of Flashes	Service Code	Causes
	PRESS TO OPERATE LOADER Button is pressed.	PRESS TO OPERATE LOADER Button is not pressed.	----	----	----	----
	Seat Bar is down.	Seat Bar is up.	Lift and tilt functions will not operate.	2	11-05	Seat Bar sensor circuit shorted to battery voltage*.
				3	11-06	Seat Bar sensor circuit shorted to ground.
				Continuous Flashing	03-09 03-10	System voltage low System voltage high
	Control valve can be used.	Control valve cannot be used.	Lift, tilt and traction functions will not operate.	1	17-07	Valve output circuit is open.
				2	17-05	Valve output circuit shorted to battery voltage*.
				3	17-06	Valve output circuit shorted to ground.
				3	17-06	Controller not grounded or intermittent ground.
				Continuous Flashing	03-09 03-10	System voltage low System voltage high
	Loader can be moved forward & backward.	Loader cannot be moved forward and backward.	Loader cannot be moved forward and backward.	1	16-07	Traction lock hold solenoid circuit is open.
				2	16-05	Traction lock hold solenoid circuit shorted to battery voltage*.
				3	16-06	Traction lock hold solenoid circuit shorted to ground.
				5	15-02	Traction lock pull solenoid circuit is shorted to battery voltage* - ERROR ON (Should be OFF).
				6	15-03	Traction lock pull solenoid circuit ERROR OFF (Should be ON).
				Continuous Flashing	03-09 03-10	System voltage low System voltage high

\* Normal BICS operating voltage is less than electrical system voltage.

## DIAGNOSTIC SERVICE CODES

### Service Codes List

CODE		CODE	
01-16	Air filter not connected	11-05	Seat bar sensor short to battery
01-17	Air filter plugged	11-06	Seat bar sensor short to ground
02-16	Hydraulic charge filter not connected	12-21	Front auxiliary PWM switch out of range high
02-17	Hydraulic charge filter plugged	12-22	Front auxiliary PWM switch out of range low
		12-23	Front auxiliary PWM switch not in neutral
03-09	Battery voltage low		
03-10	Battery voltage high	13-05	Fuel shut-off hold solenoid short to battery
03-11	Battery voltage extremely high	13-06	Fuel shut-off hold solenoid short to ground
03-14	Battery voltage extremely low	13-07	Fuel shut-off solenoid open circuit
03-22	Battery voltage out of range low		
		14-02	Fuel shut-off pull solenoid error ON
04-09	Engine oil pressure low	14-03	Fuel shut-off pull solenoid error OFF
04-14	Engine oil pressure extremely low		
04-15	Engine oil pressure shutdown level	15-02	Traction lock pull solenoid error ON
04-21	Engine oil pressure out of range high	15-03	Traction lock pull solenoid error OFF
04-22	Engine oil pressure out of range low		
		16-05	Traction lock hold solenoid short to battery
05-09	Hydraulic charge pressure low	16-06	Traction lock hold solenoid short to ground
05-14	Hydraulic charge pressure extremely low	16-07	Traction lock hold solenoid open circuit
05-15	Hydraulic charge pressure shutdown level		
05-21	Hydraulic charge pressure out of range high	17-05	Hydraulic lock valve solenoid short to battery
05-22	Hydraulic charge pressure out of range low	17-06	Hydraulic lock valve solenoid short to ground
		17-07	Hydraulic lock valve solenoid open circuit
06-10	Engine speed high		
06-11	Engine speed extremely high	18-05	Spool Lock Solenoid short to battery
06-13	Engine speed no signal	18-06	Spool Lock Solenoid short to ground
06-15	Engine speed shutdown level	18-07	Spool Lock Solenoid open circuit
06-18	Engine speed out of range		
		19-02	Bucket position solenoid error ON
07-10	Hydraulic oil temperature high	19-03	Bucket position solenoid error OFF
07-11	Hydraulic oil temperature extremely high		
07-15	Hydraulic oil temperature shutdown level	20-02	Two-speed solenoid error ON
07-21	Hydraulic oil temperature out of range high	20-03	Two-speed solenoid error OFF
07-22	Hydraulic oil temperature out of range low		
		21-02	Glow plug error ON
08-10	Engine coolant temperature high	21-03	Glow plug error OFF
08-11	Engine coolant temperature extremely high		
08-15	Engine coolant temperature shutdown level	22-02	Starter error ON
08-21	Engine coolant temperature out of range high	22-03	Starter error OFF
08-22	Engine coolant temperature out of range low		
		23-02	Rear base solenoid error ON
09-09	Fuel level low	23-03	Rear base solenoid error OFF
09-21	Fuel level out of range high		
09-22	Fuel level out of range low	24-02	Rear rod solenoid error ON
		24-03	Rear rod solenoid error OFF
10-16	Hydraulic implement filter not connected		
10-17	Hydraulic implement filter plugged		

## DIAGNOSTIC SERVICE CODES (CONT'D)

### Service Codes List (Cont'd)

CODE		CODE	
25-02	Rear auxiliary relief solenoid error ON	32-61	Handle lock short to ground
25-03	Rear auxiliary relief solenoid error OFF	32-62	Handle lock short to battery
		32-63	Pedal lock short to ground
26-02	Front base solenoid error ON	32-64	Pedal lock short to battery
26-03	Front base solenoid error OFF	32-65	Sensor supply voltage out of range
		32-66	Battery voltage out of range
27-02	Front rod solenoid error ON	32-67	Switch flipped while operating
27-03	Front rod solenoid error OFF	32-68	Lift handle information error
		32-69	Control pattern switch flipped while operating
28-02	Diverter solenoid error ON	32-70	Right drive handle short to ground
28-03	Diverter solenoid error OFF	32-71	Right drive handle short to battery
29-02	High flow solenoid error ON	33-23	Main Controller (Bobcat Controller) not programmed
29-03	High flow solenoid error OFF		
		34-04	Keyless panel no communication to Bobcat controller
30-28	Controller memory failure		
		35-02	Two-speed fan error ON
31-28	Interrupted power failure	35-03	Two-speed fan error OFF
32-04	ACS not communicating with Bobcat Controller	36-48	ACD multiple controllers present
32-23	ACS Not calibrated		
32-31	Tilt actuator fault	37-02	Two-speed secondary error ON
32-32	Tilt actuator wiring fault	37-03	Two-speed secondary error OFF
32-33	Tilt handle wiring fault		
32-34	Tilt actuator not in neutral		
32-35	Tilt handle / pedal not in neutral		
32-36	Lift actuator fault		
32-37	Lift actuator wiring fault		
32-38	Lift handle wiring fault		
32-39	Lift actuator not in neutral		
32-40	Lift handle / pedal not in neutral		
32-41	No communication		
32-49	Lift actuator short to ground		
32-50	Tilt actuator short to ground		
32-51	Lift actuator short to battery		
32-52	Tilt actuator short to battery		
32-53	Lift handle / pedal short to ground		
32-54	Tilt handle / pedal short to ground		
32-55	Lift handle / pedal short to battery		
32-56	Tilt handle / pedal short to battery		
32-57	Lift actuator reduced performance		
32-58	Tilt actuator reduced performance		
32-59	Lift actuator wrong direction		
32-60	Tilt actuator wrong direction		

## DIAGNOSTIC SERVICE CODES (CONT'D)

### Service Codes List (Cont'd)

CODE		CODE	
38-04	No communication from joystick controller	38-53	Left forward drive solenoid error OFF
38-05	Left joystick X axis not in neutral	38-54	Left reverse drive solenoid error OFF
38-06	Right joystick X axis not in neutral	38-55	Right forward drive solenoid error OFF
38-07	Left joystick Y axis not in neutral	38-56	Right reverse drive solenoid error OFF
38-08	Right joystick Y axis not in neutral	38-57	Front right extend steering solenoid error OFF
38-09	Control pattern switch - Short to Battery or Ground	38-58	Front right retract steering solenoid error OFF
38-11	Lift actuator not in neutral	38-59	Front left extend steering solenoid error OFF
38-12	Tilt actuator not in neutral	38-60	Front left retract steering solenoid error OFF
38-13	Lift actuator fault	38-61	Rear right extend steering solenoid error OFF
38-14	Tilt actuator fault	38-62	Rear right retract steering solenoid error OFF
38-15	Right wheel speed fault	38-63	Rear left extend steering solenoid error OFF
38-16	Left wheel speed fault	38-64	Rear left retract steering solenoid error OFF
38-17	Tilt actuator reduced performance	38-65	Steering pressure solenoid error OFF
38-18	Lift actuator reduced performance	38-66	Back-up alarm error OFF
38-19	Left joystick X axis out of range high	38-67	No communication from Bobcat controller
38-20	Right joystick X axis out of range low	38-68	Wheel angles (alignment) not calibrated
38-21	Left joystick Y axis out of range high	38-69	Lift & tilt actuators not calibrated
38-22	Right joystick Y axis out of range high	38-70	Interrupted power
38-23	Front right steering sensor out of range high	38-71	Battery out of range
38-24	Front left steering sensor out of range high	38-72	Drive pump not calibrated
38-25	Rear right steering sensor out of range high	38-73	Steering mode / drive mode switch flipped while operating
38-26	Rear left steering sensor out of range high	38-74	Uncommanded right wheel speed error ON
38-27	Lift actuator out of range high	38-75	Uncommanded left wheel speed error ON
38-28	Tilt actuator out of range high	38-76	Undercurrent steer pressure solenoid
38-29	Left joystick X axis out of range low	38-77	Undercurrent front right extend steer solenoid
38-30	Right joystick X axis out of range low	38-78	Undercurrent front right retract steer solenoid
38-31	Left joystick Y axis out of range low	38-79	Undercurrent front left extend steer solenoid
38-32	Right joystick Y axis out of range low	38-80	Undercurrent front left retract steer solenoid
38-33	Front right steering sensor out of range low	38-81	Undercurrent rear right extend steer solenoid
38-34	Front left steering sensor out of range low	38-82	Undercurrent rear right retract steer solenoid
38-35	Rear right steering sensor out of range low	38-83	Undercurrent rear left extend steer solenoid
38-36	Rear left steering sensor out of range low	38-84	Undercurrent rear left retract steer solenoid
38-37	5 volt sensor supply 1 out of range low	38-85	5 Volt sensor supply 1 out of range high
38-38	5 volt sensor supply 2 out of range low	38-86	5 Volt sensor supply 2 out of range high
38-39	Lift actuator short to ground / out of range low	38-87	Front right wheel blocked (steering mechanical failure)
38-40	Tilt actuator short to ground / out of range low	38-88	Front left wheel blocked (steering mechanical failure)
38-41	Tilt actuator wrong direction	38-89	Rear right wheel blocked (steering mechanical failure)
38-42	Lift actuator wrong direction	38-90	Rear left steering error
38-43	Left forward drive solenoid error ON	38-91	Right speed sensor missing pulses
38-44	Left reverse drive solenoid error ON	38-92	Left speed sensor missing pulses
38-45	Right forward drive solenoid error ON	38-93	Unresponsive right speed sensor
38-46	Right reverse drive solenoid error ON	38-94	Unresponsive left speed sensor
38-47	Front right steering solenoid error ON	38-98	Controller in drive calibration mode
38-48	Front left steering solenoid error ON	38-99	Controller in wheel position calibration mode.
38-49	Rear right steering solenoid error ON		
38-50	Rear left steering solenoid error ON		
38-51	Steering pressure solenoid error ON		
38-52	Back-up alarm error ON		



## DIAGNOSTIC SERVICE CODES (CONT'D)

### Service Codes List (Cont'd)

CODE		CODE	
39-04	Left joystick no communication to Bobcat controller	75-22	Right Joystick Y-Axis Out of Range High (H-Pattern Only)
		75-27	Left Swash Plate Out of Position
40-04	Right joystick no communication to Bobcat controller	75-28	Right Swash Plate Out of Position
		75-29	Left Joystick X-Axis Out of Range Low
44-02	Horn error ON	75-31	Left Joystick Y-Axis Out of Range Low
44-03	Horn error OFF	75-32	Right Joystick Y-Axis Out of Range Low (H-Pattern Only)
		75-37	5 Volt Sensor Supply 1 Out of Range Low
45-02	Right blinker error ON	75-39	Left Swash Plate Sensor Out of Range High
45-03	Right blinker error OFF	75-40	Left Swash Plate Sensor Out of Range Low
		75-41	Right Swash Plate Out of Range High
46-02	Left blinker error ON	75-42	Right Swash Plate Sensor Out of Range Low
46-03	Left blinker error OFF	75-43	Left Forward Drive Solenoid Error ON
		75-44	Left Reverse Drive Solenoid Error ON
47-21	8 volt sensor supply out of range high	75-45	Right Forward Drive Solenoid Error ON
47-22	8 volt sensor supply out of range low	75-46	Right Reverse Drive Solenoid Error ON
		75-52	Backup Alarm Error ON
48-02	Front light relay error ON	75-53	Left Forward Drive Solenoid Error OFF
48-03	Front light relay error OFF	75-54	Left Reverse Drive Solenoid Error OFF
		75-55	Right Forward Drive Solenoid Error OFF
49-02	Rear light relay error ON	75-56	Right Reverse Drive Solenoid Error OFF
49-03	Rear light relay error OFF	75-66	Backup Alarm Error OFF
		75-67	No Communication from Bobcat Controller
60-21	Rear auxiliary control out of range high	75-69	Battery Voltage Out of Range High
60-22	Rear auxiliary control out of range low	75-70	Interrupted Power (also occurs after software updates)
60-23	Rear auxiliary control not returning to neutral	75-71	Battery Voltage Out of Range Low
		75-72	Drive Pump Not Calibrated
64-02	Switched power relay error ON	75-73	ISO / H Pattern Switch Flipped While Operating
64-03	Switched power relay error OFF	75-74	Right Wheel Speed Uncommanded Motion
		75-75	Left Wheel Speed Uncommanded Motion
74-72	Bobcat controller in boot code	75-76	No Communication from ACS Controller
74-73	Left hand panel system RX error	75-77	Left Speed Sensor Out of Range High
		75-78	Right Speed Sensor Out of Range High
75-4	No Communication from Drive Controller	75-79	Left Speed Sensor Out of Range Low
75-5	Left Joystick X-Axis Not in Neutral	75-80	Right Speed Sensor Out of Range Low
75-7	Left Joystick Y-Axis Not in Neutral	75-85	5-Volt Sensor Supply 1 Out of Range High
75-8	Right Joystick Y-Axis Not in Neutral (H-Pattern Only)	75-91	Left Swash Sensor Reversed
75-9	ISO / H Pattern Switch Short to Ground or Battery	75-92	Right Swash Sensor Reversed
75-17	Left Swash Plate Not in Neutral	75-93	Unresponsive Right Speed Sensor
75-18	Right Swash Plate Not in Neutral	75-94	Unresponsive Left Speed Sensor
75-21	Left Joystick Y-Axis Out of Range High	75-95	Left Speed Sensor Reverse Direction
75-19	Left Joystick X-Axis Out of Range High	75-96	Right Speed Sensor Reverse Direction
75-21	Left Joystick Y-Axis Out of Range High (H-Pattern Only)	75-98	Controller in Calibration Mode



## DISPLAY CONTROLLER PANEL SETUP

### Panel Upgrade

#### Icon Identification

Figure 191

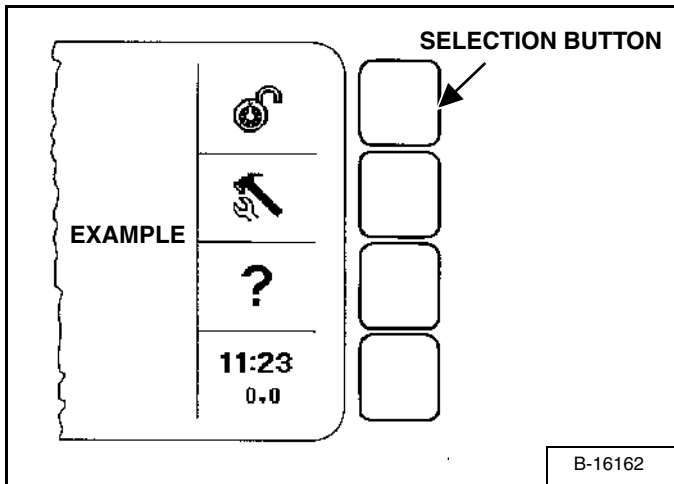

Make selection by pressing SELECTION BUTTON opposite the Icon [Figure 191].

ICON	DESCRIPTION
	<b>LOCK / UNLOCK:</b> Allows machine to be locked / unlocked. You must lock machine to activate security system.
	When system is unlocked, the user can press RUN / ENTER then press START to begin operation. A valid password will need to be entered at startup to run a locked machine.
	<b>TOOL / SETUP:</b> Access system options. Use to set clock, check system warnings, select language, set passwords, etc.
	<b>HELP:</b> Access help on current menu item.
<b>EXIT</b>	<b>EXIT</b> returns you to previous level menu.
11:23 0.0	<b>CLOCK / JOB CLOCK:</b> Press to clear or lock job clock; TOOL / SETUP to set time.
	<b>UP ARROW:</b> Goes backward one screen.
	<b>DOWN ARROW:</b> Goes forward one screen.
	<b>OUTLINE ARROWS:</b> No screen available (backward / forward).
	<b>SELECTION ARROW:</b> Use to select menu item.
<b>NEXT</b>	Goes to the NEXT screen in series. EXAMPLE: the next Active Warning screen.
<b>INFO</b>	Goes to more information about an attachment.
<b>YES / NO</b>	Answer yes / no to current setup question.
<b>CLEAR</b>	Removes previously installed password.
<b>SET</b>	Set accepts current installed password.

## DISPLAY CONTROLLER PANEL SETUP (CONT'D)

### Panel Setup

#### Display Options

Figure 192

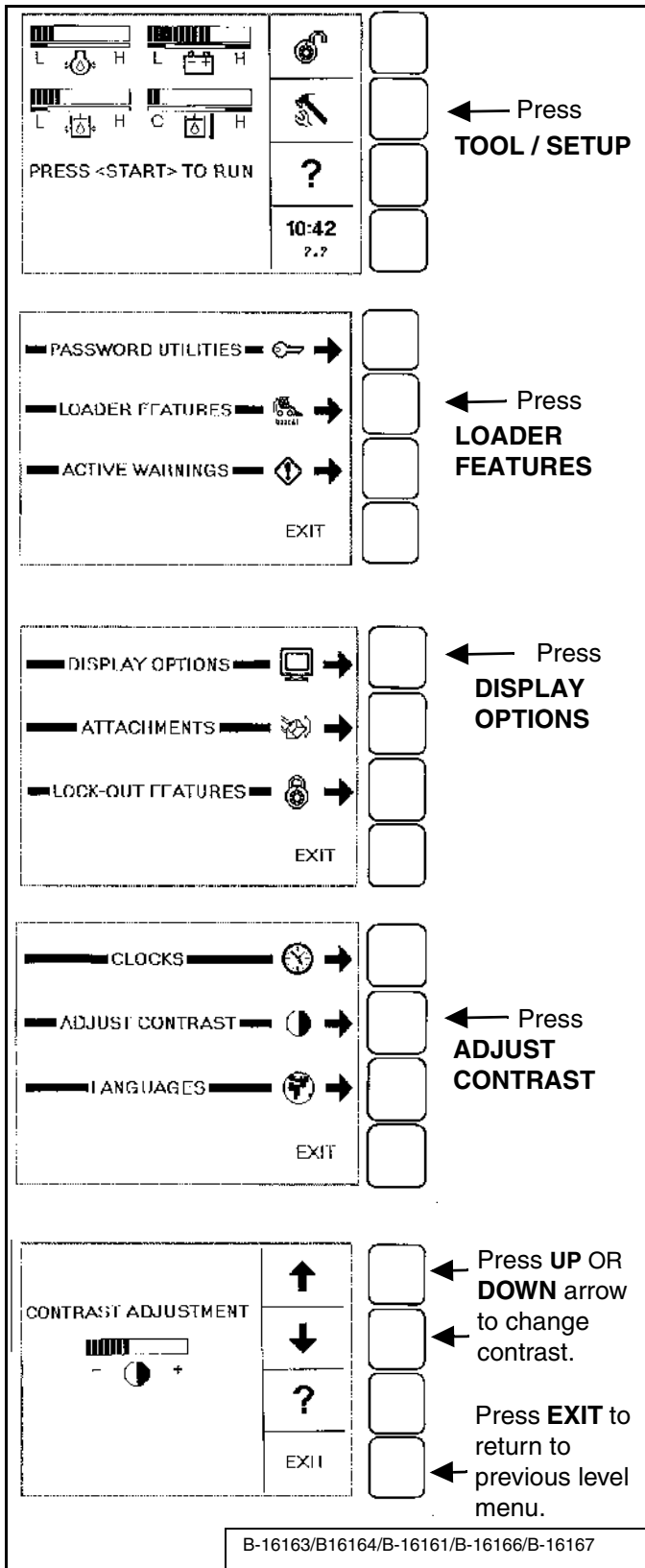

All new machines with Keyless Instrumentation arrive at Bobcat dealerships with the panel in locked mode. This means that a password must be used to start the engine [Figure 192].

### Passwords

For security purposes, your dealer may change the password and also set it in the locked mode. Your dealer will provide you with the password.

#### Owner Password:

Allows for full use of the loader and to setup the Keyless Panel. Owner can select a password to allow starting & operating the loader and modify the setup of the Keyless Panel. Owner should change the password as soon as possible for security of the loader.

#### User Password:

Allows starting and operating the loader; cannot change password or any of the other setup features.

# DISPLAY CONTROLLER PANEL SETUP (CONT'D)

## Passwords (Cont'd)

Figure 193

### Changing the Password - Right Instrument Panel Display Screen

**Press TOOL / SETUP**

**Press OWNER UTILITIES**

Enter **PASSWORD** (owner or master) on **Keypad** then press **ENTER** to Continue.

**Press PASSWORD UTILITIES**

**OWNER PASSWORD**

**Press MODIFY OWNER**

Enter new **OWNER PASSWORD** on **Keypad** then press **ENTER** to Continue.

Re-Enter new **OWNER PASSWORD** on **Keypad** then press **ENTER** to Continue.

**OWNER PASSWORD** procedure is now complete.

**USER PASSWORD**

**Press MODIFY USER**

Enter **USER** number on **Keypad** (There can be up to 8 different Users, each with their own password) then press **ENTER** to Continue.

Enter **USER PASSWORD** on **Keypad** then press **ENTER** to Continue.

**USER PASSWORD** procedure is now complete.

**Keypad**

**ENTER**

## DISPLAY CONTROLLER PANEL SETUP (CONT'D)

### Viewing Service Codes (Key Switch)

Figure 194

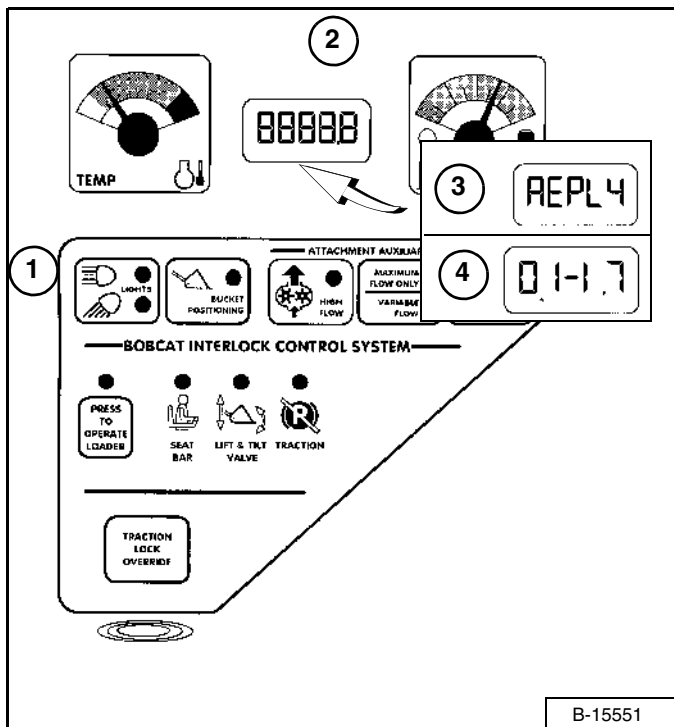

Press and hold the LIGHTS Button (1) [Figure 194] for two seconds to view SERVICE CODES in the HOURMETER / CODE DISPLAY (2). If more than one SERVICE CODE is present, the codes will scroll on the HOURMETER / CODE DISPLAY.

**NOTE:** Corroded or loose grounds can cause multiple service codes and/or abnormal symptoms. All instrument panel lights flashing, alarm sounding, headlights and taillights flashing, could indicate a bad ground. The same symptoms could apply if the voltage is low, such as loose or corroded battery cables. If you observe these symptoms, check grounds and positive leads first.

SERVICE CODES may be either a word (3) [Figure 194] or a number (4).

The following word errors may be displayed.

**REPLY** One or both instrument panel(s) not communicating with the controller.

**INPUT** The controller not communicating with the left instrument panel.

**CODE** The controller is asking for a password. (Keyless instrument panel only.)

**ERROR** The wrong password was entered. (Keyless instrument panel only.)

### Viewing Service Codes (Keyless)

The Service Codes will aid your dealer in diagnosing conditions which can damage your machine.

Figure 195

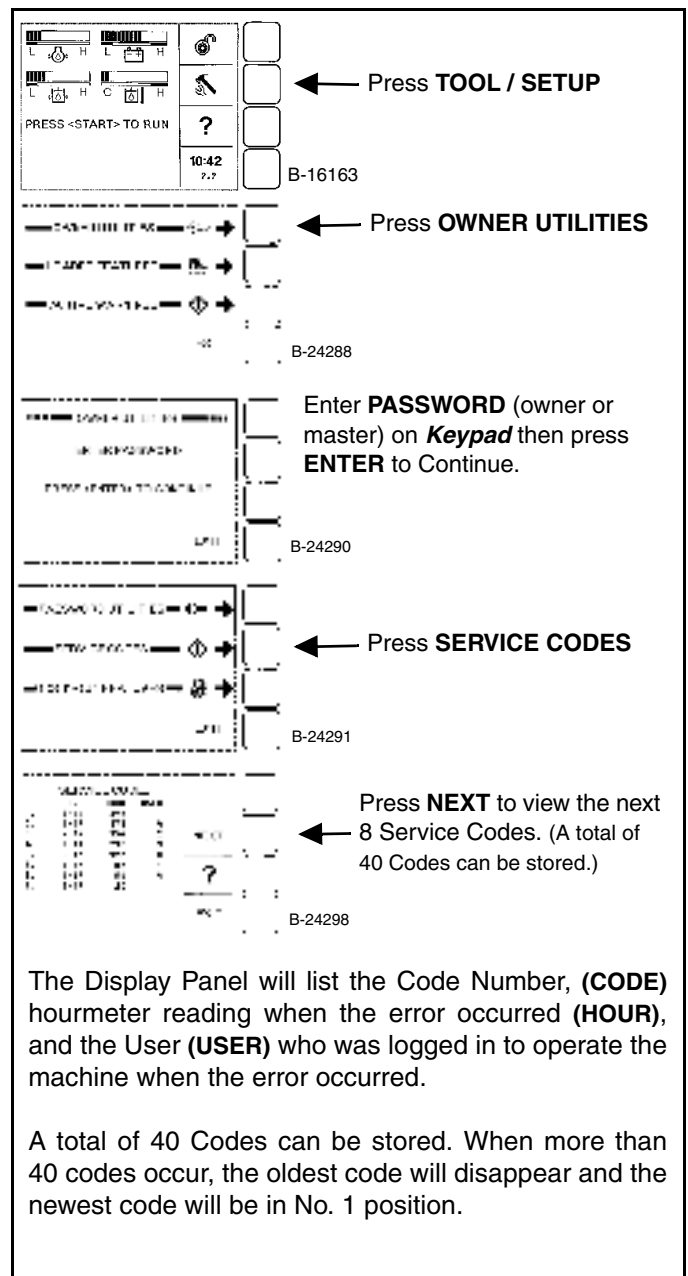

The Display Panel will list the Code Number, (CODE) hourmeter reading when the error occurred (HOUR), and the User (USER) who was logged in to operate the machine when the error occurred.

A total of 40 Codes can be stored. When more than 40 codes occur, the oldest code will disappear and the newest code will be in No. 1 position.

## DISPLAY CONTROLLER PANEL SETUP (CONT'D)

### More EXAMPLES:

#### Clocks

TOOL / SETUP  
LOADER FEATURES  
DISPLAY OPTIONS  
CLOCKS  
SET CLOCK

Use the keypad to set time.  
Press **RUN / ENTER** to set clock.  
Press **EXIT** to return to previous level menu.

#### RESET JOB CLOCK (Password required)

Press **CLEAR** to reset job clock to zero.  
Press **LOCK / UNLOCK** to unlock.  
Enter Password and press **RUN / ENTER**.

#### Languages

TOOL / SETUP  
LOADER FEATURES  
DISPLAY OPTIONS  
LANGUAGES

Select the language, press **RUN / ENTER**.  
Press **EXIT** to return to previous level menu.

Vitals (Monitor the engine, hydraulic / hydrostatic, electrical functions when engine is running.)

TOOL / SETUP  
LOADER FEATURES  
VITALS

Press **SELECTION ARROW** to select METRIC or ENGLISH (M/E) readouts

You can monitor real-time readouts of:

- Engine Oil Pressure
- Engine Coolant Temperature
- Hydraulic Charge Pressure
- Hydraulic Oil Temperature
- System Voltage
- Engine Speed

The Display Panel is easy to use. Continue to set your own preferences for running / monitoring your Bobcat Loader.

## SHUTDOWN FEATURE

### Procedure

Figure 196

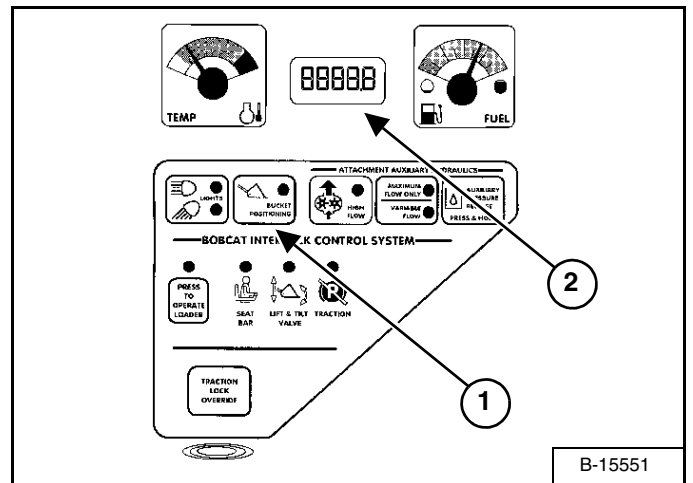

Press and hold the BUCKET POSITIONING Button (1) [Figure 196] for two seconds. If the SHUTDOWN feature is installed, **Shtdn** will appear in the HOURMETER / CODE DISPLAY (2) [Figure 196]. If it is not installed, **BASE** will appear.

The Operational Code (Software version) will also appear.

See your Bobcat dealer about installation of this feature.



**Bobcat®**



## SPECIFICATIONS

(S205) LOADER SPECIFICATIONS .....	119
Controls.....	122
Drive System.....	121
Electrical .....	120
Engine.....	120
Environmental .....	121
Fluid Capacities .....	122
Fluid Specifications .....	122
Function Time .....	120
Hydraulic Cylinders .....	121
Hydraulic System .....	121
Instrumentation .....	123
Loader Dimensions .....	119
Machine Rating .....	120
Traction .....	121
Weights .....	120

**SPECIFICATIONS**



**Bobcat®**

## (S205) LOADER SPECIFICATIONS

### Loader Dimensions

- Dimensions are given for loader equipped with standard dirt bucket and may vary with other bucket types. All dimensions are shown in millimeters.
- Where applicable, specifications conform to SAE or ISO standards and are subject to change without notice.

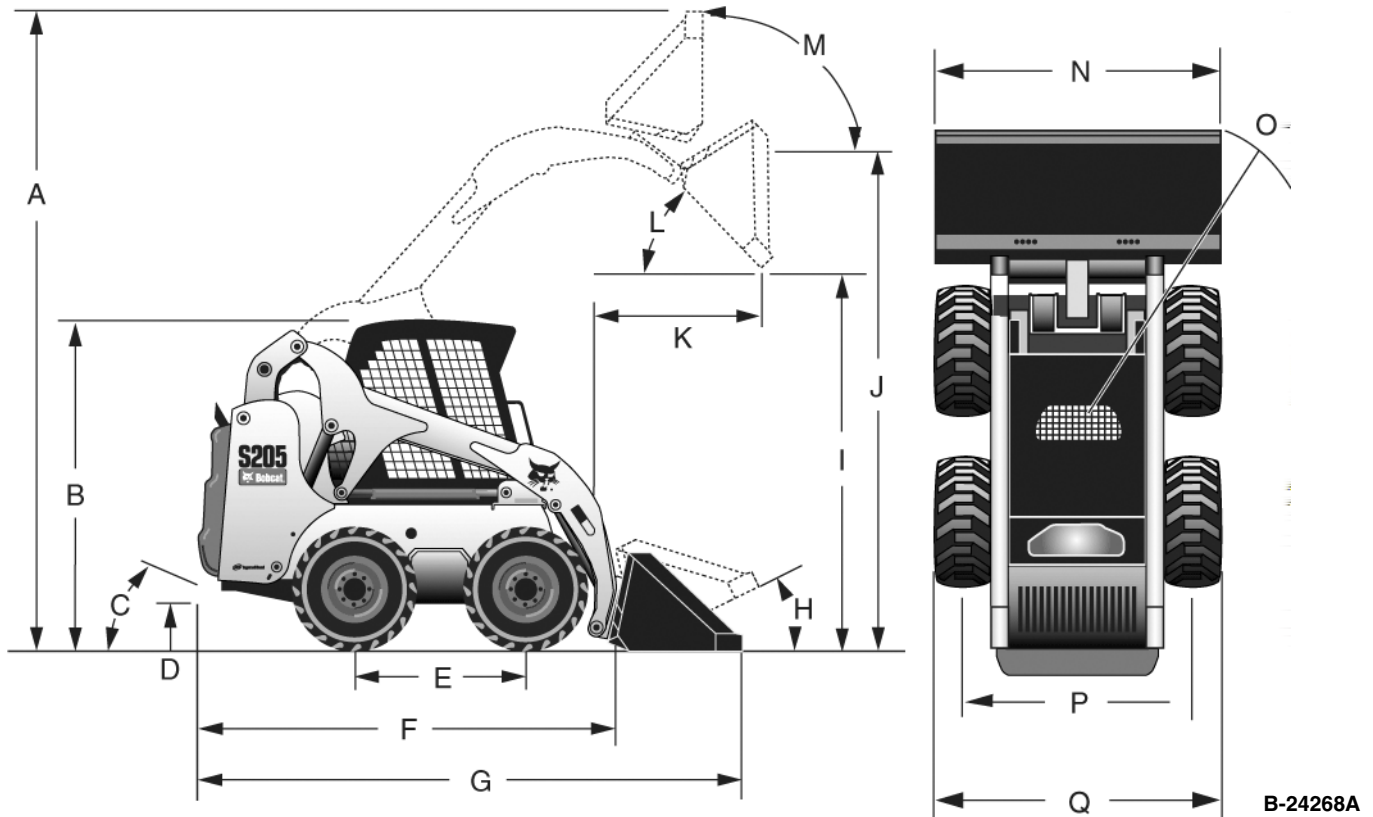

B-24268A

(C) Angle of Departure .....	23°
Carry position .....	228 mm
(L) Dump angle at maximum height .....	42°
(I) Dump height with standard bucket .....	2310 mm
(K) Dump reach at maximum height.....	753 mm
(D) Ground clearance .....	191 mm
(J) Height to bucket hinge pin .....	3002 mm
(B) Height with operator cab.....	1938 mm
(F) Length without attachment.....	2588 mm
(G) Length with standard bucket.....	3309 mm
(A) Operating height .....	3862 mm
(H) Rollback at ground position .....	25°
(M) Rollback fully raised at maximum height.....	95°
(E) Wheelbase.....	1030 mm
(O) Turning radius with standard bucket.....	2001 mm
(Q) Width over tyres, 31 x 12-16.5, 10 ply.....	1676 mm
(P) Track, 31 x 12-16.5 tyres - 10 ply.....	1382 mm
(N) Bucket width, 68-inch .....	1727 mm
Bucket width, 74-inch .....	1880 mm

**Changes of structure or weight distribution of the loader can cause changes in control and steering response and can cause failure of the loader parts.**

## (S205) LOADER SPECIFICATIONS (CONT'D)

### Machine Rating

Lift breakout force	1690 daN
Tilt breakout force	1701 daN
Rated operating capacity	930 kg
Tipping load	2019 kg
Axle torque	5423 Nm

### Function Time

Raise lift arms	3,50 s
Lower lift arms	2,30 s
Bucket rollback	1,90 s
Bucket dump	2,50 s

### Weights

Operating weight	3023 kg
Shipping weight	2658 kg

### Engine

Make / Model	Kubota / V2403-M-DI-TE2B-BC-I
Fuel	Diesel
Cooling	Liquid
Power at 2700 RPM	45,5 kW
Rated speed (EEC 80/1269, ISO 9249)	2700 RPM
Low idle speed	1195-1245 RPM
High idle speed	2860-3000 RPM
Torque at 1475 RPM (SAE JI 995 Gross)	218 Nm
Number of cylinders	4
Displacement	2433 cm <sup>3</sup>
Bore	87,1 mm
Stroke	102,3 mm
Lubrication	Gear pump pressure
Crankcase ventilation	Open
Air filter	Dry replaceable cartridge with separate safety element
Ignition	Diesel-compression
Starting aid	Glow plugs

### Electrical

Alternator	Belt driven - 90 A - open
Battery	12 V - 600 cold cranking A at -18°C - 115 min reserve capacity
Starter	12 V - gear reduction type - 2,7 kW

## (S205) LOADER SPECIFICATIONS (CONT'D)

### Hydraulic System

Pump type	Engine driven, gear type
Pump capacity at 3028 RPM	62,0 l/min
Pump capacity at 3028 RPM - high flow option	96,5 l/min
System relief at Quick Couplers	22,4-23,1 MPa
Control valve	Three-spool, open-centre type with float detent on lift and electrically controlled auxiliary spool
Hydraulic filter	Full-flow replaceable - 3 µm synthetic media element
Fluid lines	SAE standard tubelines, hoses, and fittings

### Hydraulic Cylinders

Lift cylinder (2)	Double-acting
Lift cylinder bore	63,5 mm
Lift cylinder rod	38,1 mm
Lift cylinder stroke	601,2 mm
Tilt cylinder (2)	Double-acting with cushioning feature on dump and rollback
Tilt cylinder bore	69,9 mm
Tilt cylinder rod	34,9 mm
Tilt cylinder stroke	335,0 mm

### Drive System

Transmission	Infinitely variable tandem hydrostatic piston pumps, driving two fully reversing hydrostatic motors
Final drive chains	Pre-stressed #80 HSOC endless roller chain (no master link) and sprockets in sealed chaincase with oil lubrication. (Chains do not require periodic adjustments.) Two chains per side with no idler sprocket.
Main drive	Fully hydrostatic; four-wheel drive
Axle size	50,8 mm, heat treated. Axle tubes welded to chaincase. Labyrinth axle seal protection.
Wheel bolts	Eight 9/16-inch wheel bolts fixed to axle hubs

### Traction

Standard tyres	31 x 12-16.5, 10-ply, Bobcat Heavy Duty Wide Flotation
Travel speed	0-11,27 km/h

### Environmental

Operator $L_{pA}$ (98/37 & 474-1)	85 dB(A)
Noise level $L_{WA}$ (EU Directive 2000/14/EC)	101 dB(A)
Whole body vibration (ISO 2631-1)	0,77 $ms^{-2}$
Hand-arm vibration (ISO 5349-1)	1,27 $ms^{-2}$

## (S205) LOADER SPECIFICATIONS (CONT'D)

### Fluid Capacities

Chaincase reservoir capacity	30,3 l
Cooling system capacity with heater	11,4 l
Cooling system capacity without heater	10,2 l
Engine oil with filter capacity	8,7 l
Fuel tank capacity	90,8 l
Hydraulic reservoir capacity	18,2 l
Hydraulic / Hydrostatic system capacity	34,1 l

### Fluid Specifications

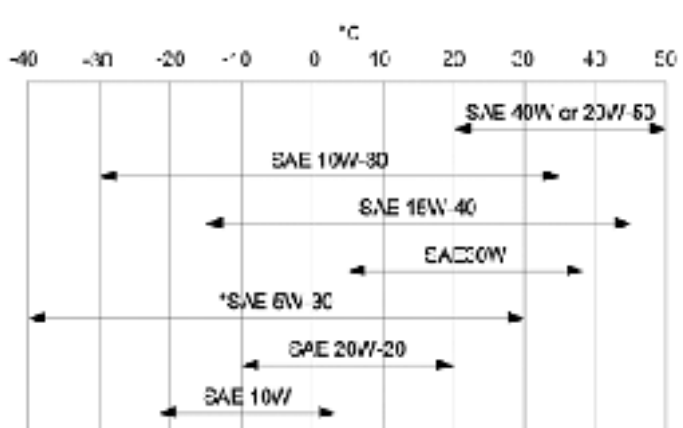
Engine coolant	Polypropylene glycol/water mix (53% - 47%) with freeze protection to -37°C
Engine oil	<p>Oil must meet API Service Classification of CD, CE, CF4, CG4, or better. Recommended SAE viscosity number for anticipated temperature range.</p>  <p>The chart shows the following temperature ranges for SAE grades:</p> <ul style="list-style-type: none"> <li>SAE 10W-30: -30°C to 30°C</li> <li>SAE 15W-40: -15°C to 40°C</li> <li>SAE 20W-20: -10°C to 20°C</li> <li>SAE 10W: -10°C to 0°C</li> <li>*SAE 6W-30: -10°C to 30°C</li> <li>SAE 30W: 0°C to 30°C</li> <li>SAE 40W or 20W-50: 20°C to 50°C</li> </ul>
Hydraulic fluid	Bobcat Fluid (P/N 6563328).

\* Can be used only when available with appropriate diesel rating. For synthetic oil use the recommendation from the oil manufacturer.

### Controls

Engine	Hand lever throttle
Starting	Key-type starter switch and shutdown. Glow plugs automatically activated by Standard or Deluxe instrument panel.
Front auxiliary (standard)	Electrical switch on right-hand steering lever
Rear auxiliary (optional)	Electrical switch on left-hand steering lever
Loader hydraulics tilt and lift	Separate foot pedals, optional Advanced Control System (ACS) or Advanced Hand Controls (AHC) or Selectable Joystick Control (SJC)
Service brake	Two independent hydrostatic systems controlled by two hand-operated steering levers
Secondary brake	One of the hydrostatic transmissions
Parking brake	Mechanical disc, hand operated rocker-switch on dash panel
Vehicle steering	Direction and speed controlled by two hand levers
Auxiliary pressure release	Pressure is relieved through the coupler block. Push in and hold for 5 s.

## (S205) LOADER SPECIFICATIONS (CONT'D)

### Instrumentation

The following loader functions are monitored by a combination of gauges and warning lights in the operator's line of sight. The system alerts the operator of monitored loader malfunctions by way of audible alarm and visual warning lights.

#### *Standard Instrument Panel*

- Gauges
  - Engine coolant temperature
  - Fuel
  - Hour-meter
- Indicators
  - Attachment Control Device
  - Bobcat Interlock Control System
  - Glow plugs
- Warning lights
  - Advanced Control System (ACS)
  - Selectable Joystick Control (SJC)
- Engine air filter
- Engine coolant temperature
- Engine oil pressure
- Fuel level
- General warning
- Hydraulic filter
- Hydraulic oil temperature
- Hydrostatic charge temperature
- Seat belt
- System voltage

#### *Deluxe Instrument Panel (Option)*

Same gauges, warning lights and other features as Standard Instrument Panel, plus:

- Bar-type gauges
  - Engine oil pressure
  - System voltage
  - Hydrostatic charge pressure
  - Hydraulic oil temperature
- Additional features
  - Keyless start with password capability
  - Digital clock
- Job clock
- Attachments information
- Digital tachometer
- High Flow lockouts
- Multi-language display
- Help screens
- Diagnostic capability
- Engine/hydraulic systems shutdown function



**Bobcat®**



# WARRANTY

## BOBCAT LOADERS

INGERSOLL RAND INTERNATIONAL warrants to its authorised dealers who in turn warrant to the end-user/owner that each new Bobcat loader will be free from proven defects in material and workmanship for twelve months from the date of delivery to the end-user/owner or 2000 hours of machine usage, whichever occurs first.

During the warranty period, the authorised selling Bobcat dealer shall repair or replace, at INGERSOLL RAND INTERNATIONAL's option, without charge for parts, labour and travel time of mechanics, any part of the Bobcat product which fails because of defects in material and workmanship. The end-user/owner shall provide the authorised Bobcat dealer with prompt written notice of the defect and allow reasonable time for replacement or repair. INGERSOLL RAND INTERNATIONAL may, at its option, request failed parts to be returned to the factory. Transportation of the Bobcat product to the authorized Bobcat dealer for warranty work is the responsibility of the end-user/owner.

The warranty does not apply to tyres or other trade accessories not manufactured by INGERSOLL RAND INTERNATIONAL. The owner shall rely solely on the warranty, if any, of the respective manufacturers thereof. The warranty does not cover replacement of scheduled service items such as oil, filters, tune-up parts, and other high-wear items. The warranty does not cover damages resulting from abuse, accidents, alterations, use of the Bobcat product with any bucket or attachment not approved by INGERSOLL RAND INTERNATIONAL, air flow obstructions, or failure to maintain or use the Bobcat product according to the instructions applicable to it.

INGERSOLL RAND INTERNATIONAL EXCLUDES OTHER CONDITIONS, WARRANTIES OR REPRESENTATIONS OF ALL KINDS, EXPRESSED OR IMPLIED, STATUTORY OR OTHERWISE (EXCEPT THAT OF TITLE) INCLUDING ALL IMPLIED WARRANTIES AND CONDITIONS RELATING TO MERCHANTABILITY, SATISFACTORY QUALITY AND FITNESS FOR A PARTICULAR PURPOSE.

CORRECTIONS BY INGERSOLL RAND INTERNATIONAL OF NONCONFORMITIES WHETHER PATENT OR LATENT, IN THE MANNER AND FOR THE TIME PERIOD PROVIDED ABOVE, SHALL CONSTITUTE FULFILMENT OF ALL LIABILITIES OF INGERSOLL RAND INTERNATIONAL FOR SUCH NONCONFORMITIES, WHETHER BASED ON CONTRACT, WARRANTY, TORT, NEGLIGENCE, INDEMNITY, STRICT LIABILITY OR OTHERWISE WITH RESPECT TO OR ARISING OUT OF SUCH PRODUCT.

THE REMEDIES OF THE END-USER/OWNER SET FORTH UNDER THE PROVISIONS OF THE WARRANTY OUTLINED ABOVE ARE EXCLUSIVE AND THE TOTAL LIABILITY OF INGERSOLL RAND INTERNATIONAL INCLUDING ANY HOLDING, SUBSIDIARY, ASSOCIATED OR AFFILIATED COMPANY OR DISTRIBUTOR WITH RESPECT TO THIS SALE OR THE PRODUCT AND SERVICE FURNISHED HEREUNDER IN CONNECTION WITH THE PERFORMANCE OR BREACH THEREOF, OR FROM DELIVERY, INSTALLATION, REPAIR OR TECHNICAL DIRECTION COVERED BY OR FURNISHED UNDER THIS SALE, WHETHER BASED ON CONTRACT, WARRANTY, TORT, NEGLIGENCE, INDEMNITY, STRICT LIABILITY OR OTHERWISE SHALL NOT EXCEED THE PURCHASE PRICE OF THE PRODUCT UPON WHICH SUCH LIABILITY IS BASED.

INGERSOLL RAND INTERNATIONAL INCLUDING ANY HOLDING, SUBSIDIARY, ASSOCIATED OR AFFILIATED COMPANY AND DISTRIBUTOR SHALL IN NO EVENT BE LIABLE TO THE END-USER/OWNER, ANY SUCCESSORS IN INTEREST OR ANY BENEFICIARY OR ASSIGNEE RELATING TO THIS SALE FOR ANY CONSEQUENTIAL, INCIDENTAL, INDIRECT, SPECIAL OR PUNITIVE DAMAGES ARISING OUT OF THIS SALE OR BY ANY BREACH THEREOF, OR ANY DEFECT IN, OR FAILURE OF, OR MALFUNCTION OF THE PRODUCT UNDER THIS SALE, WHETHER BASED UPON LOSS OF USE, LOST PROFITS OR REVENUE, INTEREST, LOST GOODWILL, WORK STOPPAGE, IMPAIRMENT OF OTHER GOODS, LOSS BY REASON OF SHUTDOWN OR NON-OPERATION, INCREASED EXPENSES OF OPERATION OR CLAIMS OF USER OR CUSTOMERS OF THE USER FOR SERVICE INTERRUPTION WHETHER OR NOT SUCH LOSS OR DAMAGE IS BASED ON CONTRACT, WARRANTY, TORT, NEGLIGENCE, INDEMNITY, STRICT LIABILITY OR OTHERWISE.



**Bobcat**®