

SMCS - 1157

SENR74100036

Remove Flywheel Housing (Industrial Engine)

Start By:

- a. remove turbocharger
 - b. remove crankshaft rear seal
 - c. remove oil pan
1. Remove the fuel filter bracket from the flywheel housing.

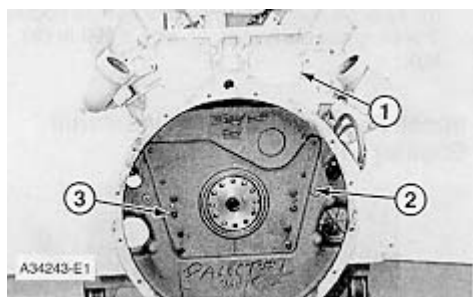

2. Remove eight bolts (3) and four bolts (2) from the inside of the flywheel housing.

3. Remove two covers (1).

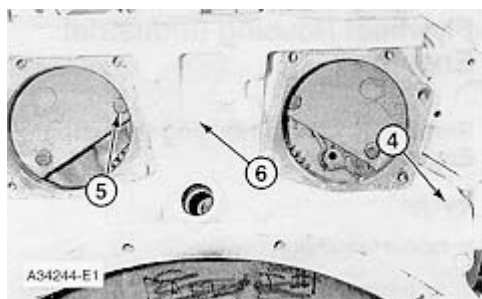

4. Remove bolts (5) from behind covers (1). Remove bolts (4).

5. Install two 5/16" -18 NC forged eyebolts in support (6). Fasten a hoist and remove the flywheel housing. The weight of the flywheel housing is **200 lb. (90 kg.)**.

Install Flywheel Housing (Industrial Engine)



1. Put a new gasket (1) in position on the cylinder block.
2. Put flywheel housing (3) into position on the cylinder block with dowels (2) in alignment with the holes in the housing.

NOTE: Put **9S3263 Thread Lock** on bolts 17 thru 20 before installation.

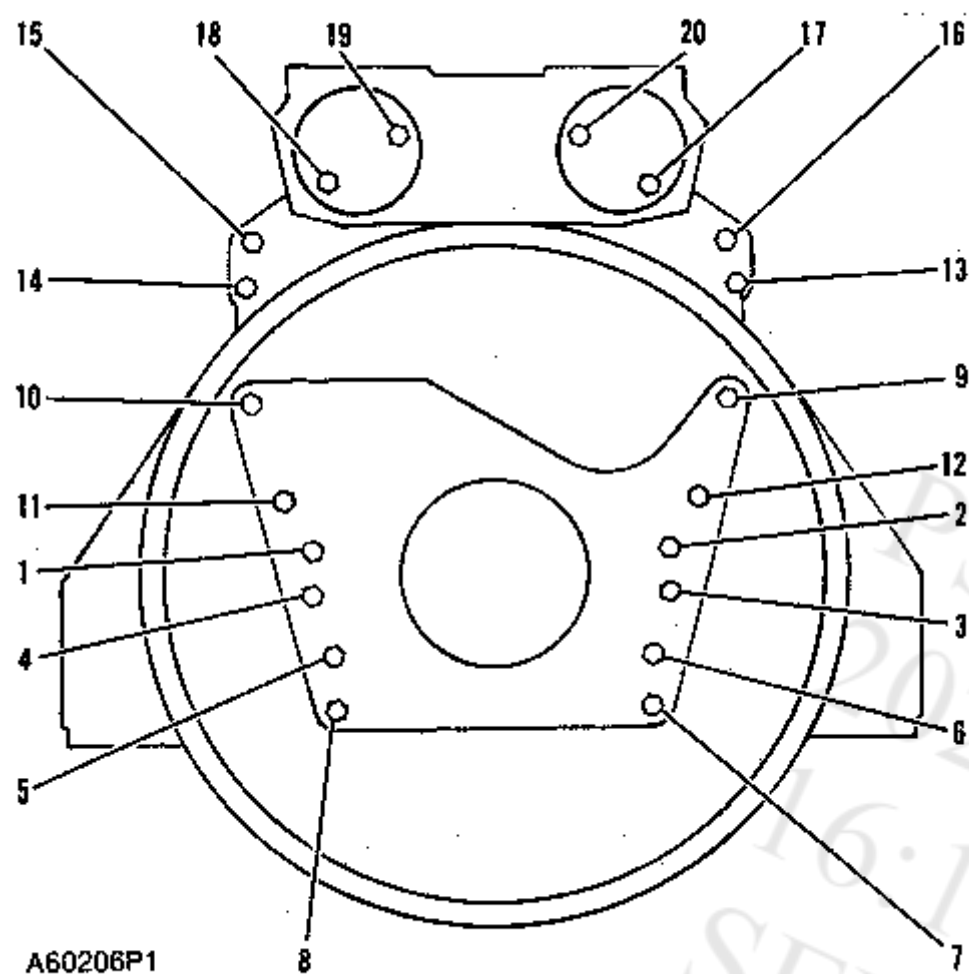

A60206P1

3. Install the correct bolts in the housing. Tighten the bolts that hold the flywheel housing to the block in the sequence that follows:

- a. Tighten bolts 1 thru 20 in number sequence to $40 \pm 10 \text{ N}\cdot\text{m}$ ($30 \pm 7 \text{ lb ft}$).
- b. Again tighten bolts 1 thru 8 in number sequence to $135 \pm 20 \text{ N}\cdot\text{m}$ ($100 \pm 15 \text{ lb ft}$).
- c. Again tighten bolts 9 thru 20 in number sequence to $55 \pm 10 \text{ N}\cdot\text{m}$ ($40 \pm 7 \text{ lb ft}$).

4. Cut the flywheel housing gasket even with the bottom of the cylinder jack.

NOTE: See Flywheel Housing Runout & Flywheel Housing Bore for the correct methods of flywheel housing inspection.

5. Install the two covers.

6. Install the fuel filter bracket on the side of the flywheel housing.

End By:

- a. install oil pan
- b. install crankshaft rear seal
- c. install turbocharger

PSP-000890C4

2022/11/30

16:10:06-03:00

SEN74100036

© 2022 Caterpillar Inc.

Caterpillar:

Confidential Green