

Component Locations by Versions					
Description	Part Number NA	Part Number ES	Part Number STD	Machine Location	Schematic Location
Cylinder Gp - Articulate - Left	SEE COMPONENT CHART			1	F-7
Cylinder Gp - Articulate - Right	SEE COMPONENT CHART			2	F-7
Cylinder Gp - Blade Lift	132-4929	132-4929	132-4929	3	F-4, F-11
Cylinder Gp - Blade Tip	131-7191	131-7191	ATTACHMENT	4	F-10
Cylinder Gp - Center Shift	6E-1343	6E-1343	6E-1343	5	F-6
Cylinder Gp - Side Shift	112-5575	112-5575	ATTACHMENT	6	F-11
Cylinder Gp - Steering - Left	130-9041	130-9041	130-9041	7	F-8
Cylinder Gp - Steering - Right	130-9042	130-9042	130-9042	8	F-8
Cylinder Gp - Wheel Leren	121-6242	121-6242	121-6242	9	F-9
Motor Gp - Circle Drive	105-3196	105-3196	105-3196	10	F-9
Pump Gp - HMU	102-1501	102-1501	102-1501	11	E-8
Pump Gp - Sec. Steering	ATTACHMENT	ATTACHMENT	N/A	12	C-6
Pump Gp - Steering / Implement	6E-3137	6E-3137	6E-3137	13	B-8
Swivel Gp	173-1011	173-1011	ATTACHMENT	14	F-10
Tank Gp - Hydraulic	214-1984	214-1984	214-1984	15	B-9
Valve Gp - Check	ATTACHMENT	ATTACHMENT	N/A	16	B-7
Valve Gp - Check	ATTACHMENT	ATTACHMENT	N/A	17	C-6
Valve Gp - Combination	9T-5957	9T-5957	9T-5957	18	C-8
Valve Gp - Left Bank	6E-3038	130-3117	104-8672	19	E-9 to E-11
Valve Gp - Relief	ATTACHMENT	ATTACHMENT	N/A	20	C-6
Valve Gp - Right Bank	6E-3032	130-3116	124-3255	21	E-4 to E-7

Component Chart				
Description	12H / 140H	160H	Machine Location	Schematic Location
Cylinder Gp - Articulate - Left	9T-8784	137-6792	1	F-7
Cylinder Gp - Articulate - Right	6E-1560	137-6790	2	F-7

Attachments by Versions					
Description	Part Number NA	Part Number ES	Part Number STD	Machine Location	Schematic Location
Accumulator Gp - Blade Cushion	162-7450	219-7265	N/A	30	F-5, F-12
Cylinder Gp - Blade Tip	STANDARD	STANDARD	6E-1549	31	I-2
Cylinder Gp - Ripper	113-7754	113-7754	113-7754	32	I-4, I-7, I-10
Cylinder Gp - Scarifier	165-2510	165-2510	165-2510	33	I-4, I-7, I-11
Cylinder Gp - Side Shift	STANDARD	STANDARD	112-5575	34	I-3
Pump Gp - Sec. Steering	123-8867	STANDARD	N/A	12	C-6
Swivel Gp	STANDARD	STANDARD	173-1011	14	I-3
Valve Gp - Relief	9T-8071	STANDARD	N/A	20	C-6
Valve Gp - Blade Cushion	7T-6517	7T-6517	N/A	35	E-5, E-11
Valve Gp - Blade Tip	STANDARD	STANDARD	6E-3034	36	H-3
Valve Gp - Check	9T-6146	STANDARD	N/A	16	B-7
Valve Gp - Check	9T-1013	STANDARD	N/A	17	C-6
Valve Gp - Side Shift	STANDARD	STANDARD	6E-3036	37	H-3

Attachments - NA Version				
Description	12H	140H / 160H	Machine Location	Schematic Location
Valve Gp - Plow Angle	N/A	115-1007	40	E-2
Valve Gp - Plow Dozer	107-0547	107-0547	41	E-2
Valve Gp - Ripper	107-0545	107-0545	42	H-7
Valve Gp - Scarifier	107-0543	107-0543	43	H-7
Valve Gp - Snow Wing Lift	N/A	137-8106	44	H-8
Valve Gp - Snow Wing Tilt	N/A	137-8104	45	H-8

Attachments - ES Version				
Description	12H	140H / 160H	Machine Location	Schematic Location
Valve Gp - Plow Angle	N/A	130-3111	40	E-2
Valve Gp - Plow Dozer	107-0547	107-0547	41	F-2
Valve Gp - Ripper	119-9550	119-9550	42	H-10
Valve Gp - Scarifier	119-9549	119-9549	43	H-10
Valve Gp - Snow Wing Lift	N/A	137-8106	44	H-11
Valve Gp - Snow Wing Tilt	N/A	137-8104	45	H-11

Attachments - STD Version				
Description	12H	140H / 160H	Machine Location	Schematic Location
Valve Gp - Plow Dozer	124-2885	124-2885	40	C-2
Valve Gp - Ripper	107-0545	107-0545	41	H-4
Valve Gp - Scarifier	107-0543	107-0543	42	H-4
Valve Gp - Snow Wing Lift	N/A	137-8106	43	H-5
Valve Gp - Snow Wing Tilt	N/A	137-8104	44	H-5

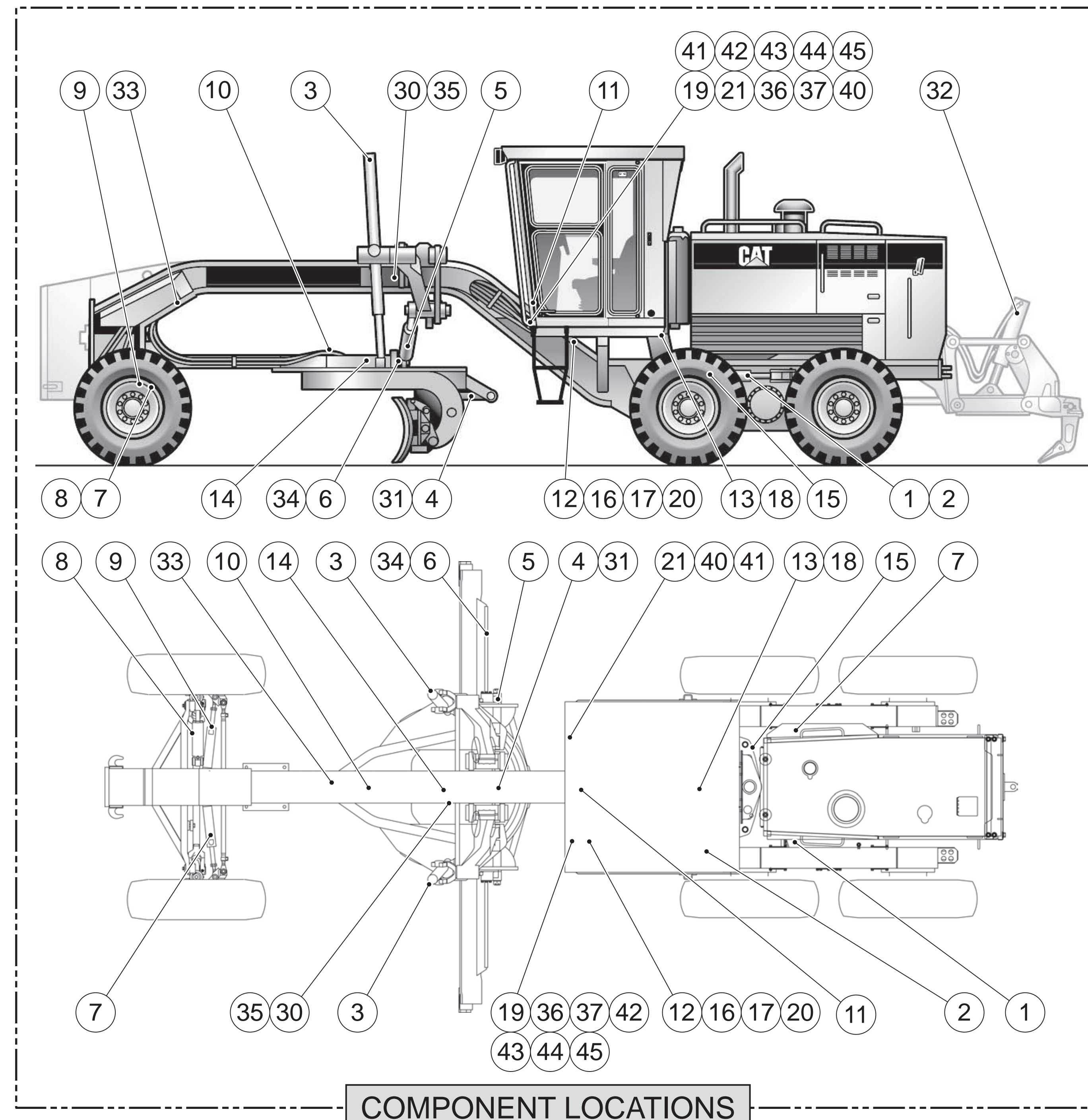

COMPONENT LOCATIONS



REN1430-02
April 2007

Schematic

12H, 140H, and 160H Motor Graders
Standard, NA, and ES Versions
Hydraulic System

- XZH1-UP
- XZJ1-UP
- XZK1-UP
- 2FM1-UP
- 5HM1-UP
- 8JM1-UP
- 9JM1-UP
- 4ER1-UP

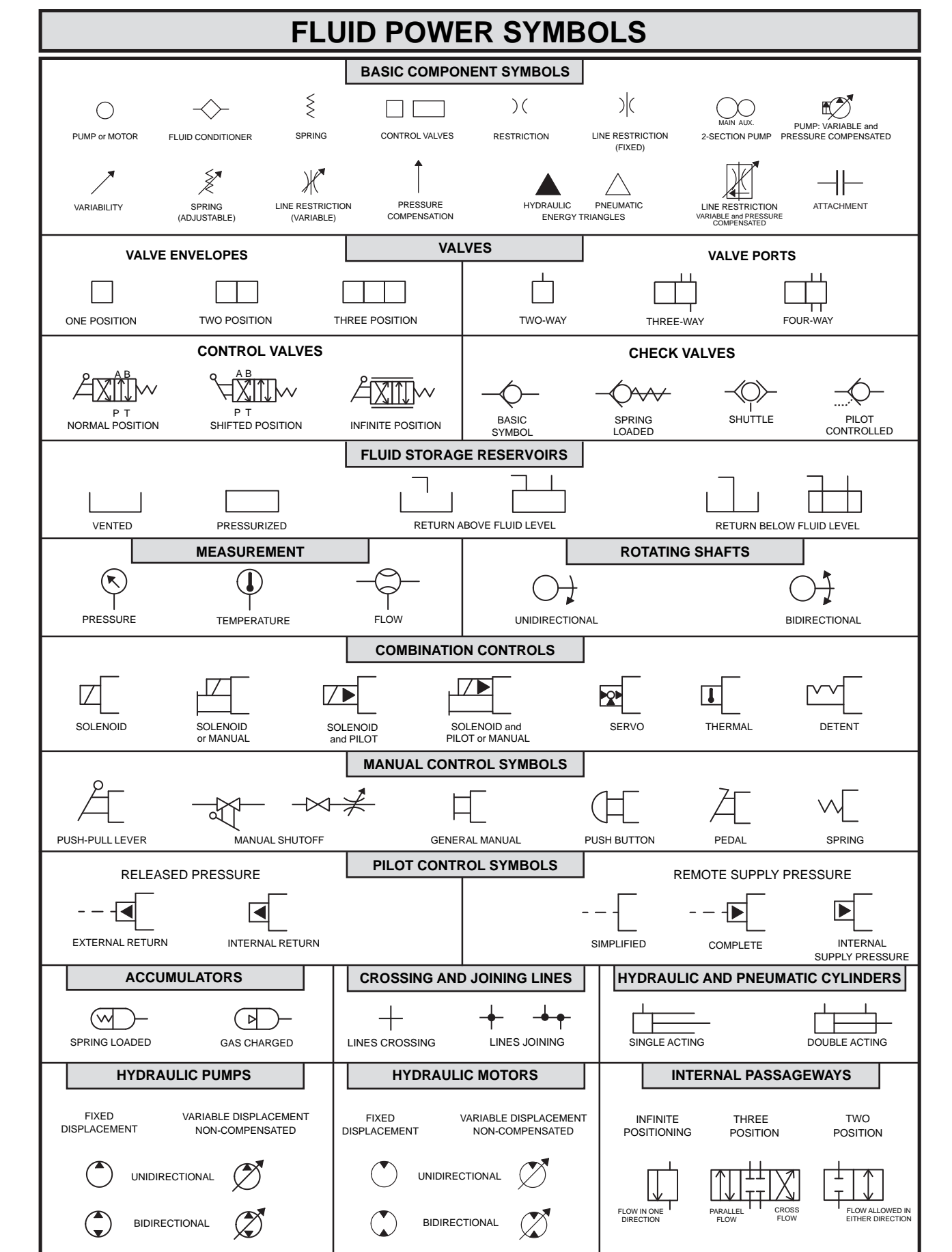

©2007 Caterpillar
All Rights Reserved

Printed in U.S.A.

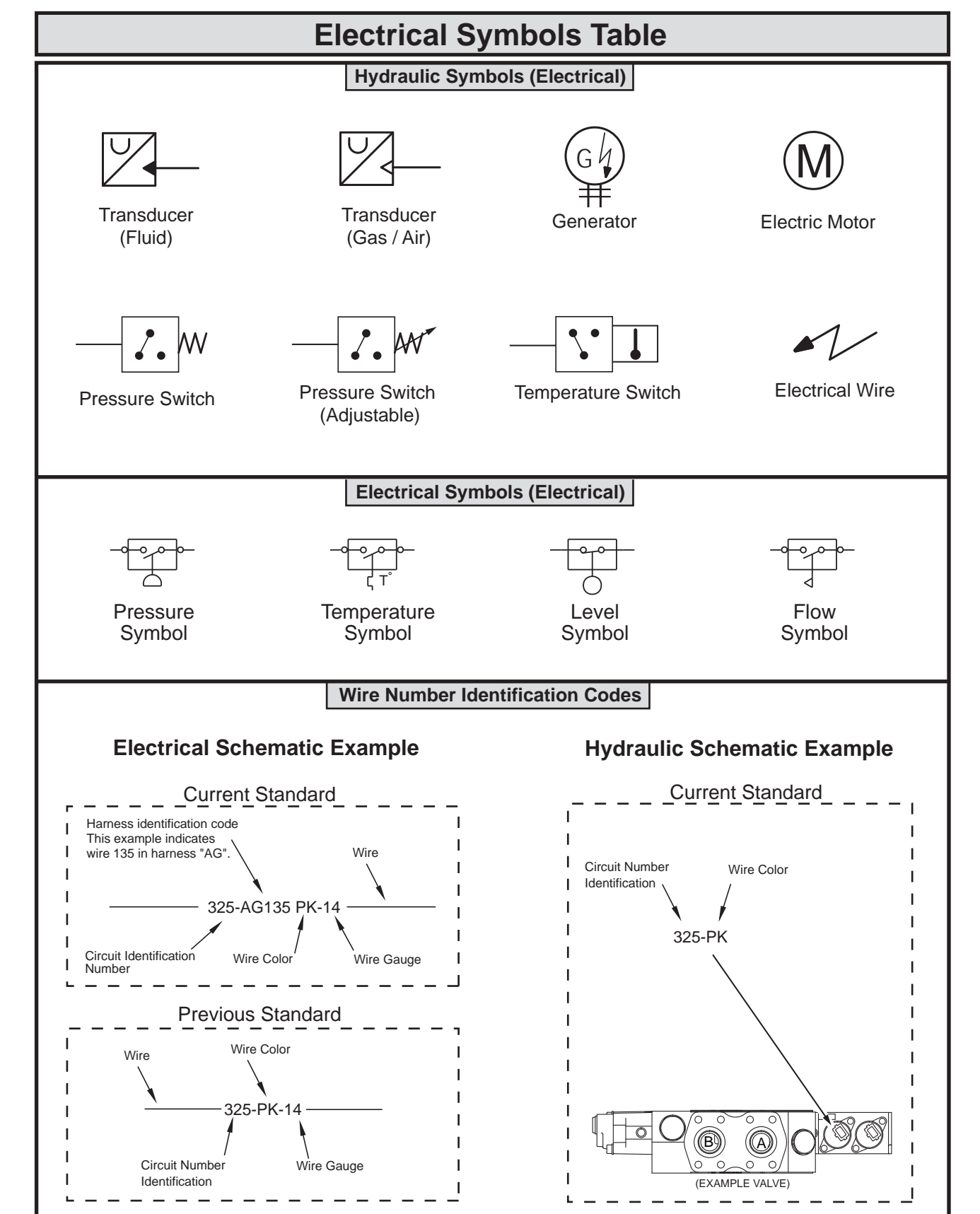

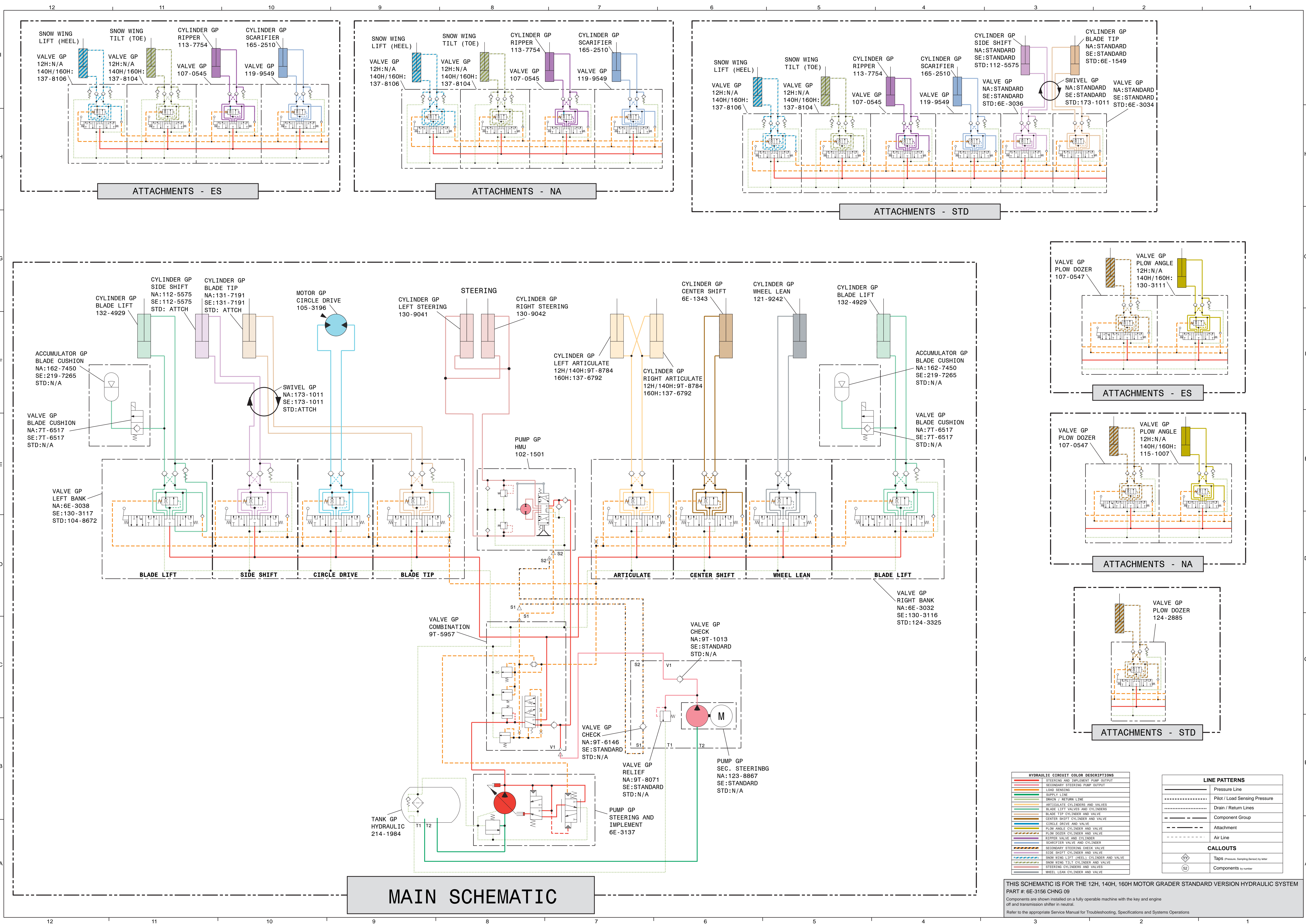

HYDRAULIC CIRCUIT COLOR DESCRIPTIONS	
[Red Line]	STEERING AND IMPLEMENT PUMP OUTPUT
[Orange Line]	SECONDARY STEERING PUMP OUTPUT
[Green Line]	LOAD SENSING
[Blue Line]	SUPPLY LINE
[Yellow Line]	DRAIN / RETURN LINE
[Light Blue Line]	ARTICULATE CYLINDERS AND VALVES
[Light Green Line]	BLADE LIFT VALVES AND CYLINDERS
[Light Purple Line]	BLADE TIP CYLINDER AND VALVE
[Light Orange Line]	CENTER SHIFT CYLINDER AND VALVE
[Light Yellow Line]	CIRCLE DRIVE AND VALVE
[Light Cyan Line]	FLOW ANGLE CYLINDER AND VALVE
[Light Magenta Line]	PLOW DOZER CYLINDER AND VALVE
[Light Blue-Gray Line]	RIPPER VALVE AND CYLINDER
[Light Green-Gray Line]	SCARIFIER VALVE AND CYLINDER
[Light Purple-Gray Line]	SECONDARY STEERING CHECK VALVE
[Light Orange-Gray Line]	SIDE SHIFT CYLINDER AND VALVE
[Light Yellow-Gray Line]	SNOW WING LIFT (HEEL) CYLINDER AND VALVE
[Light Cyan-Gray Line]	SNOW WING TILT (TOE) CYLINDER AND VALVE
[Light Magenta-Gray Line]	STEERING CYLINDERS AND VALVES
[Light Blue-Gray Line]	WHEEL LEAN CYLINDER AND VALVE

LINE PATTERNS	
[Solid Line]	Pressure Line
[Dashed Line]	Pilot / Load Sensing Pressure
[Dotted Line]	Drain / Return Lines
[Dashed Box]	Component Group
[Dashed Line]	Attachment
[Dotted Line]	Air Line

CALLOUTS	
[Diamond]	TAPS (Present, Sampling Sensor by Offer)
[Circle]	Components by number

THIS SCHEMATIC IS FOR THE 12H, 140H, 160H MOTOR GRADER STANDARD VERSION HYDRAULIC SYSTEM
PART #: 6E-3156 CHNG 09
Components are shown installed on a fully operable machine with the key and engine
off and transmission shifter in neutral.
Refer to the appropriate Service Manual for Troubleshooting, Specifications and Systems Operations