

DKG-171 AUTO TRANSFER SWITCH INSTALLATION AND OPERATING INSTRUCTIONS

DESCRIPTION

The DKG-171 is a microprocessor controlled unit designed to monitor the 3-phase mains voltages, send remote start command to the generating set and make changeover of both generator and mains contactors.

The front panel mimic diagram provides information about mains and generator power availability as well as contactor positions.

The low limit of the mains and genset voltages may be manually adjusted via the potentiometer situated on the left side of the unit. The leftmost position corresponds to 70 volts, the middle position to 170 volts and the rightmost position to 270 volts-AC.

OPERATION

The DKG-171 continuously monitors the AC mains phase voltages. If at least one of the phase voltages goes outside set limits, it initiates a transfer cycle like below:

- The green **MAINS** led turns to red.
- The unit deenergizes the mains contactor output and the green **LOAD MAINS** led is extinguished.
- After **Wait Before Remote Start Delay**, the **Remote Start** output is energized. The generator remote start unit receives this signal and runs the engine.
- When the generator phase voltage is within set limits, the yellow **GENSET** led will illuminate and the unit will allow the genset to run without load during the **Engine Heating Period**.
- When the **Engine Heating Period** is elapsed, the yellow **LOAD GENSET** led will start blinking and the unit will wait for the **Generator Contactor Delay**.
- At the end of the **Generator Contactor Delay**, the generator contactor output will be energized and the yellow **LOAD GENSET** led will illuminate steadily.
- When all mains phase voltages are within limits, the **MAINS** led will turn to green and the unit waits for **Mains Return Delay** for stabilization.

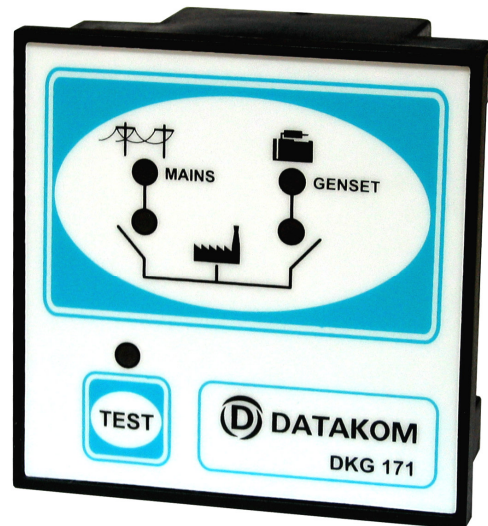

-At the end of the Mains Return Delay, the yellow **LOAD GENSET** led is extinguished, the generator contactor output is deenergized and the green **LOAD MAINS** led will start blinking. The unit will wait for **Mains Contactor Delay**.

-At the end of the Mains Contactor Delay the green **LOAD MAINS** led will illuminate steadily, the mains contactor output is energized and the **Remote Start** output is deenergized. The unit will wait ready for a new mains failure sequence.

The DKG-171 provides a **TEST** mode pushbutton allowing the genset to be tested without a mains failure.

In **TEST** mode, the Remote Start output will be energized but no load transfer will take place unless the occurrence of a mains failure. If the mains fail, the load will be transferred to the genset. When the mains voltages are within limits the load will be transferred to the mains, but the genset will be kept running. It will only stop if the **TEST** mode is cancelled.

TYPICAL CONNECTION DIAGRAM

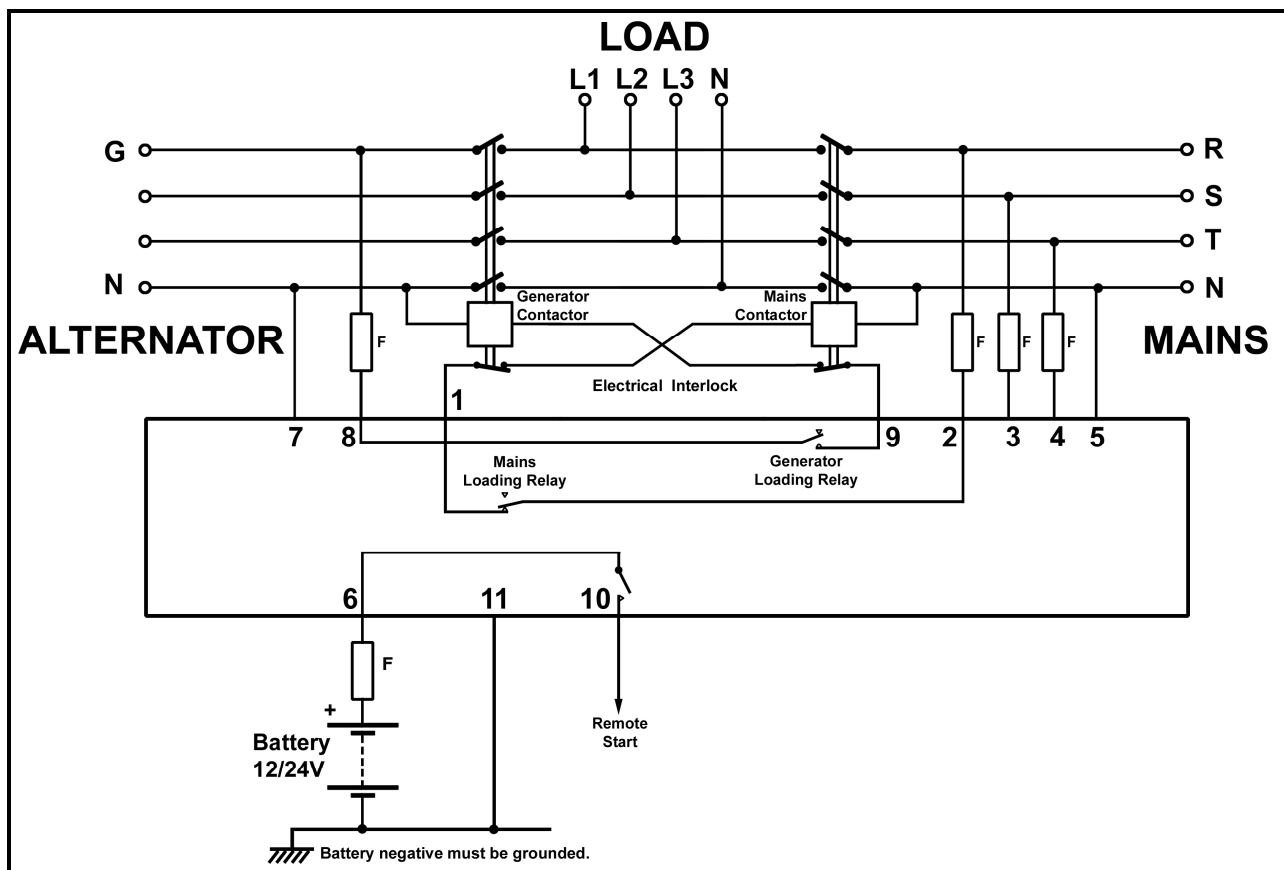

INPUTS

DC SUPPLY: 12 or 24 volts DC, (+) and (-) terminals.

R-S-T: Mains phase voltages.

MN: Mains neutral terminal.

G: Generator phase voltage.

GN: Generator neutral terminal.

OUTPUTS

MAINS CONTACTOR: Normally closed relay output connecting the phase-R voltage to the terminal. (10amps@250V-AC)

GENERATOR CONTACTOR: Normally open relay output connecting the phase-G voltage to the terminal. (10amps@250V-AC)

REMOTE START: Normally open engine start request relay output. Connects the battery positive voltage to the terminal. (10amps@28V-DC)

TECHNICAL SPECIFICATIONS

Alternator Voltage: 300 V-AC max.

Mains voltages: 300 V-AC max (Ph-N)

DC Supply Range: 8 to 33 V-DC.

Current consumption: 80mA max. (outputs open).

Wait Before Remote Start: 3 sec.

Engine Heating Period: 5 sec.

Generator Contactor Delay: 0.75 sec.

Mains Return Delay: 30 sec.

Mains Contactor Delay: 0.75 sec.

Low Voltage Limit: Adjustable from 70 to 270V-AC.

High Voltage Limit: 320 V-AC Ph-N (fixed)

Operating temp.: -20°C (-4°F) to 70 °C (158°F).

Storage temp.: -30°C (-22°F) to 80 °C (176°F).

Maximum humidity: 95% non-condensing.

Dimensions: 72x72x38mm (WxHxD)

Panel cutout dimensions: 68x68 mm

Weight: 140g (approx.)

Installation: Front panel mounted. Retaining steel spring provided.