

GTR-17

Generator Controller

Manual



Tres Arroyos 329 - Haedo (1706)
Buenos Aires - Argentina

☎: (54-11) 4926-0600 / 4483-3630

☎: (54-11) 4627-3500

E-mail: cram@speedy.com.ar

Web Site: www.cramelectro.com

Table of Content

1. Controller Description.....	2
2. Profile	2
3. Back Panel Function Description.....	3
4. Case Dimension	4
5. Specifications	5
6. Controller Wiring Example.....	6

1. Controller Description

GTR-17 is low cost but multi-function diesel engine generator controller. It applies with 3 buttons and provides 3 kinds of operation mode: Manual, Auto, Off. No special training is required due to the easy operation. Fault protection includes: Emergency stop, Over speed, High water temperature, Low oil pressure, and Over crank. GTR-17 also displays the low battery voltage warning, and indicates the running status and power status. GTR-17 equips with high firm continental-type terminal that provides easy plug in and removal. Furthermore, GTR-17 has 10 pins Dip switch for adjusting parameter according to system requirements, and make it not only reducing stock but also meeting the various system specifications. GTR-17 build-in 5 output powers relays which perform high power capacity reach to 5 Amp (DC) that saves the wiring for connection with extra power relays. No matter in function, protection or operation performance. GTR-17 is your best choice.

2. Profile



Fig. 17 Front Panel

A 、LED Indication

- Emergency / Auxiliary Shutdown
- Low Battery Warning
- Over Speed Shutdown
- High Water Temperature Shutdown
- Low Oil Pressure Shutdown
- Over Crank
- Run
- Power

B 、Operation Buttons

- ATS
Auto Start function by detect ATS terminal 12 grounded.
- Off
Stop running engine or stand still / Reset Alarm.
- Manual
Manual start engine directly.

3. Back Panel Function Description

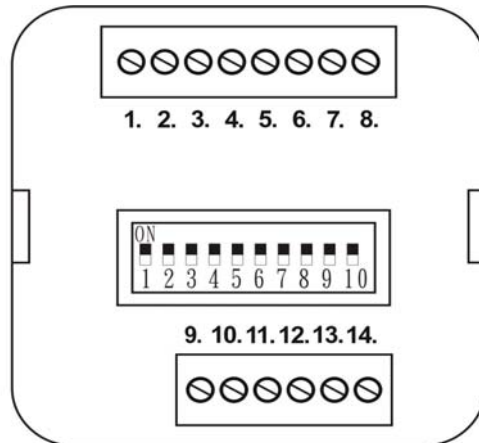

Fig. 2 GTR-17 Controller Back Panel

E u r o p i u m S t y l e C o n n e c t o r	Number	Description	Code
	1	Input power (Battery +)	++
	2	Ground (Battery -)	GND
	3	Output starter relay	Motor
	4	Output fuel valve relay	Valve
	5	Output alarm relay	Alarm
	6	Output stop relay	Stop
	7	Output Idle/Pre-heat relay	Pre-Heat
	8	Charge fire point	Charge
	9	Aux. switch shutdown	Em.Stop
	10	Input , High water temp. switch	H.W.T.
	11	Input, Low oil press. switch	L.O.P.
	12	Input , Auto start	ATS
	13	Input , Frequency detect terminal	F.D1
14	Input , Frequency detect terminal	F.D2	

List 1 GTR-17 Terminal

A 、 Dip switch settings function

- Pin 1 & Pin 2 : Valve on to stop engine timer

Pin1	Pin2	Valve on stop engine delay
OFF	OFF	5 sec
ON	OFF	10 sec
OFF	ON	15 sec
ON	ON	20 sec

List 2 Stop Period

- Pin3 : System frequency 【ON : 50Hz ; OFF : 60Hz】
- Pin4 : Escape motor by oil pressure switch 【ON : Enable ; OFF : Disable】
- Pin5 : Pressure switch type 【ON : Normal Open ; OFF : Normal Close】
- Pin6 : Idle / Pre-heat output delay time 【ON : 10 (120) Sec ; OFF : 1 (300) Sec】
- Pin7 : Low DC Volt 【ON : 10.5VDC ; OFF : 21VDC】
- Pin8 & Pin9 Cooling time :

Pin8	Pin9	Cooling time
OFF	OFF	0 Sec
ON	OFF	60 Sec
OFF	ON	150 Sec
ON	ON	300 Sec

List 3 Cooling Time

- Pin10 : Idle / Pre-heat Function Select 【ON : Idle ; OFF : Pre-heat】

4. Case Dimension

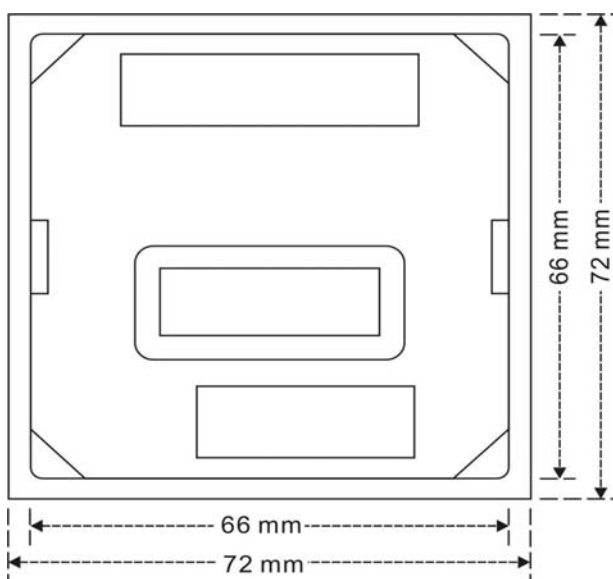

Fig. 3 GTR-17 Case Dimension of Back View

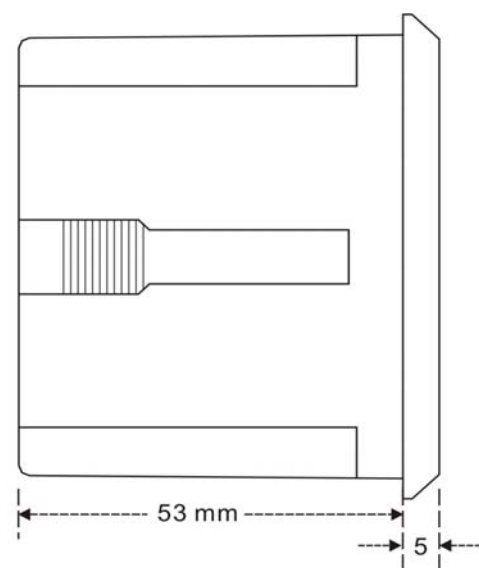

Fig. 4 GTR-17 Case Dimension of Side View

5. Specifications

DC supply :

8~36 VDC

Power Consumption :

Max.5 W

Measuring Frequency :

0~75 Hz (min AC Volt.25V ; max AC Volt. 300V)

Relay Output :

Start output : 5A

Valve output : 5A

Idle / Pre-heat output : 5A

Alarm Output : 5A

Stop output : 5A

Ambient Temperature Range :

-10 °C ~ 60 °C

Dimension (W * H * D) :

72mm x 72 mm x 58 mm

Panel cut-out (W * H) :

68 mm x 68 mm

Weight :

190g (0.42 lb.)

Protections and parameters :

Auxiliary shutdown protection : 1 Sec., Normal Close

Low battery warning : 5 Sec., 10.5 / 21 VDC

Over speed protection : 2 Sec.,55/66Hz

High water temp. protection : 2 Sec., Normal Open

Low oil pressure protection: 2 Sec., Normal Open / Normal Close

Over crank : 3 attempts

Cranking speed up limited : 0.5 Sec ., 20Hz

Safety on timer: 5 Sec (*)

(*) All alarms are ignored until safety on timer expired, except the emergency stop and over speed.

6. Controller Wiring Example

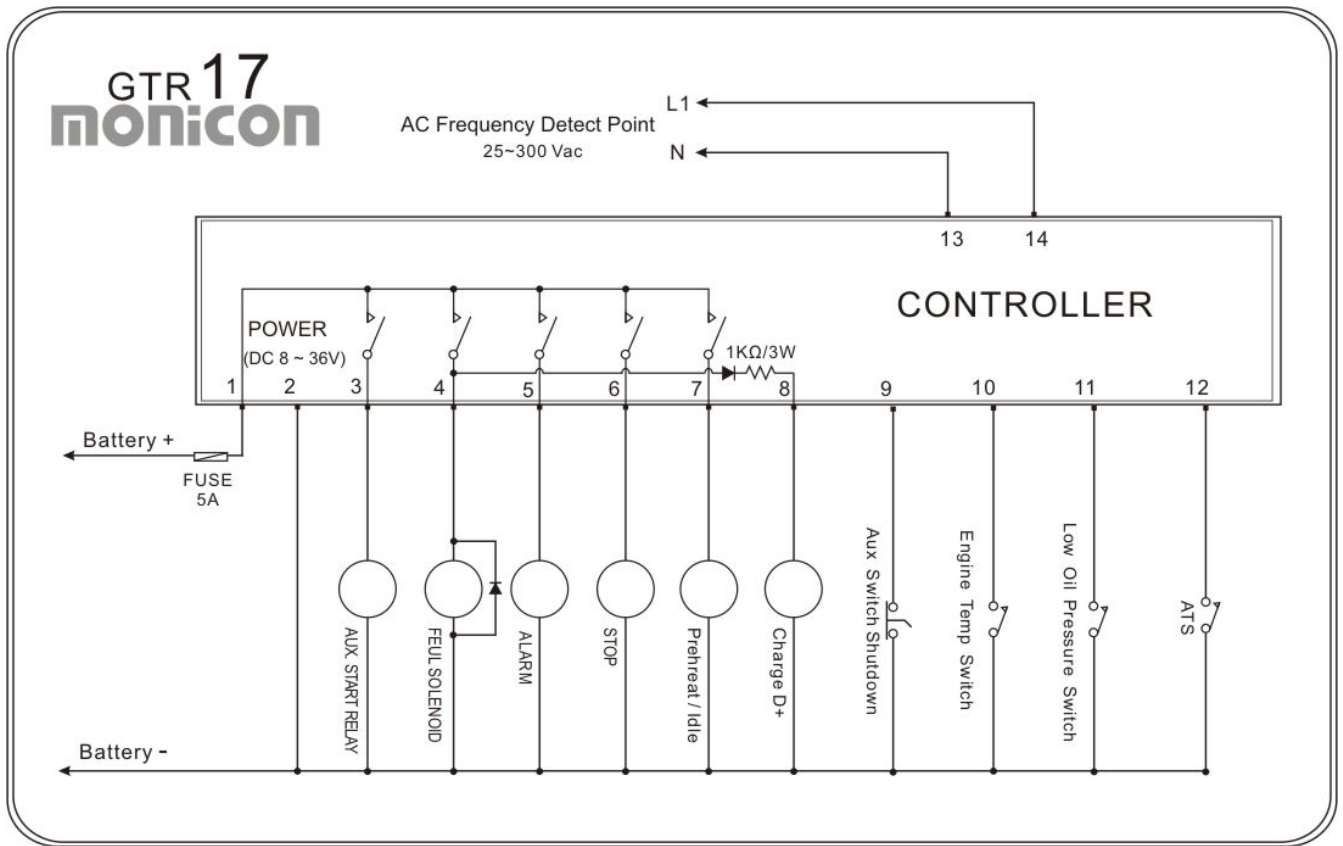

Fig. 5 Controller wiring