

HGM180/180HC
AUTO START MODULE

OPERATING MANUAL



CONTENT

1. DESCRIPTION.....	3
2. SPECIFICATION.....	3
3. OPERATION	4
4. OVER SPEED PROTECTION	5
5. CHARGE FAILURE WARNING	5
6. CONFIGURATION	5
7. TERMINAL DESCRIPTION	6
8. CASE DIMENSIONS.....	7
9. TYPICAL CONNECTIONS.....	8

1. DESCRIPTION

The **HGM180** auto start module is an engine control module designed to control the engine via a key switch and remote start signal or pushbuttons on the front panel. The module is used to start and stop the engine and indicate fault conditions, automatically shutting down the engine and indicating the engine failure by LED, giving true, first-up fault annunciation.

The module is housed in an enclosed robust plastic case for front panel mounting. Connections to the module are via plug and sockets.

The **HGM180hc** has an inbuilt LCD hours counter, which displays the number of hours that the generator has run, to the nearest 1/10 hour.

2. SPECIFICATION

DC Supply

8 to 35V continuous.

Alternator Input Range

15 - 300VAC(+20%) RMS

Alternator Input Frequency

50 - 60 Hz at rated engine speed.

Over speed: nominal frequency +14% (+24% Overshoot)

Start Output

Relay 1A plant battery positive B+ terminal

Fuel Output

Relay 1A plant battery positive B+ terminal

Pre-heat Output

Relay 1A plant battery positive B+ terminal

Stop Output

Relay 1A plant battery positive B+ terminal

Configurable Output

Relay 1A plant battery positive B+ terminal. This output can configure Alarm output or Idle output by the code switch on the under side. When idle output is effectual, it is active at full speed.

Four switch Inputs

Switch to negative.

Fixed Settings

Crank Disconnect: Generator voltage ≥ 15 VAC frequency ≥ 15 Hz

Charge Failure Voltage: ≤ 3 V

Remote start delay: 2seconds

Crank period: 5seconds

Crank rest: 10seconds

Safety delay: 10seconds

Remote stop delay: 10seconds

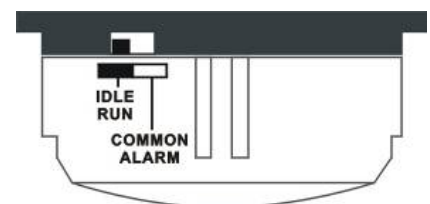

Hours counter

Maximum hour counts: 99999.9h

Case Dimensions



84mm x 72mm x 35mm



Operating Temperature Range

-30 to +70°C

ICON AND LED

 : High temperature alarm LED

 : Low oil pressure alarm LED

 : Over speed alarm LED



 : Charge Failure warn LED

 : Common alarm LED



: LCD hour count

3. OPERATION

If you use hgm180/180hc for the first time, configure is necessary. If you want to configure the module, please look Configuration.

Operation of the module is via a three position key switch mounted on the front panel with OFF(O), START () and AUTO() positions. In the 'O' position the output are de-energized.

Manual Operation:

1. Select manual run ()
2. Depress pre-heat button for required length of time
3. Press START () to crank engine

Once the Start button is pressed and maintained, the engine fuel system is energized. After 1s, the 'Crank' output is then energized and the starter motor operated, disengaging automatically when the engine fires or when the 'Start' button is released. The protection hold-off timer is then initiated.

Automatic Operation:

1. Select AUTO()
2. When **Remote Start** is active, the generator will automatic start.

Stop Operation:

Turn the key to OFF (**O**), the engine will stop. The stop relay will energize for 30 second (maximum) or 10s (when the engine has stopped).

Operation of any of the following alarms (which are close on fault) will cause the run output to de-energize:

- . **Low Oil Pressure**
- . **High Engine Temperature**
- . **Auxiliary Shutdown**
- . **Over speed**

This will remove the fuel supply from the engine and bring it to rest. Each alarm has its own LED indicator and once activated no further alarm conditions will be accepted. The alarm output and relevant LED will remain active until the unit is reset by turning the switch to the '**O**' position.



4. Over speed Protection







































































Over speed protection is derived from the generator Hz output. The over frequency circuit monitors the generator Hz output and will shut down the engine immediately if a pre-set frequency level is exceeded. This trip level is 114% of nominal frequency.



5. Charge Failure warning

Charge Failure warning is also provided by monitoring the WL terminal on the charge alternator. This operates on a similar principal to the warning lamp fitted in a motor vehicle, should the output fail the charge fail LED will illuminate. The module will also provide the alternator excitation current via this connection.

6. Configuration

6.1 Turn the position key to the '**O**' position, press the set button () over 5 second, configuration mode will is selected. The Pre-Heat button () can be used to select the following item ,The set button () will allow the user to change the value of the function.

Item						Value
Pre-heat time						0 Seconds(<i>Default</i>)
						5 Seconds
						10 Seconds
						20 Seconds
						30 Seconds
						60 Seconds
						120 Seconds
Alternator Frequency						50Hz(<i>Default</i>)
						60Hz
Idle time						5 Seconds
						10 Seconds(<i>Default</i>)
						15 Seconds
						20 Seconds
						30 Seconds
						60 Seconds
						120 Seconds
						180 Seconds
Oil pressure disengage starter motor						Disable
						Enable (<i>Default</i>)

Note:  indicate LED to illumine,  indicate LED to extinguish.

6.2 Turn the position key to the '**AUTO**' position or the '' position, quit configuration mode.

7. TERMINAL DESCRIPTION

PIN NO	DESCRIPTION	CABLE SIZE	NOTES
1	DC Plant supply input (B-)	1.0mm	Connected to plant battery negative
2	DC Plant supply input (B+)	1.0mm	Connected to plant battery positive (Recommended Fuse 6A)
3	Fuel relay output	0.5mm	Used to operate the fuel solenoid control relay.
4	Start relay output	0.5mm	Used to operate the cranking control relay.
5	Preheat output	0.5mm	Used to operate the preheat control relay.
6	Auxiliary shutdown input	0.5mm	Switch to negative on fault.
7	Charge fail input/ excitation output	1.0mm	Must NOT be connected to plant supply negative if not used.

PIN NO	DESCRIPTION	CABLE SIZE	NOTES
8	Low oil pressure switch input	0.5mm	Switch to negative on fault.
9	High engine temperature switch Input	0.5mm	Switch to negative on fault.
10	Alternator input L	1.0mm	2A Fuse
11	Alternator input N	1.0mm	
12	Configurable output	0.5mm	Used to operate the auxiliary control relay.
13	Stop output	0.5mm	Used to operate the stop control relay.
14	Remote start input	0.5mm	Switch to negative to start set.

8. CASE DIMENSIONS

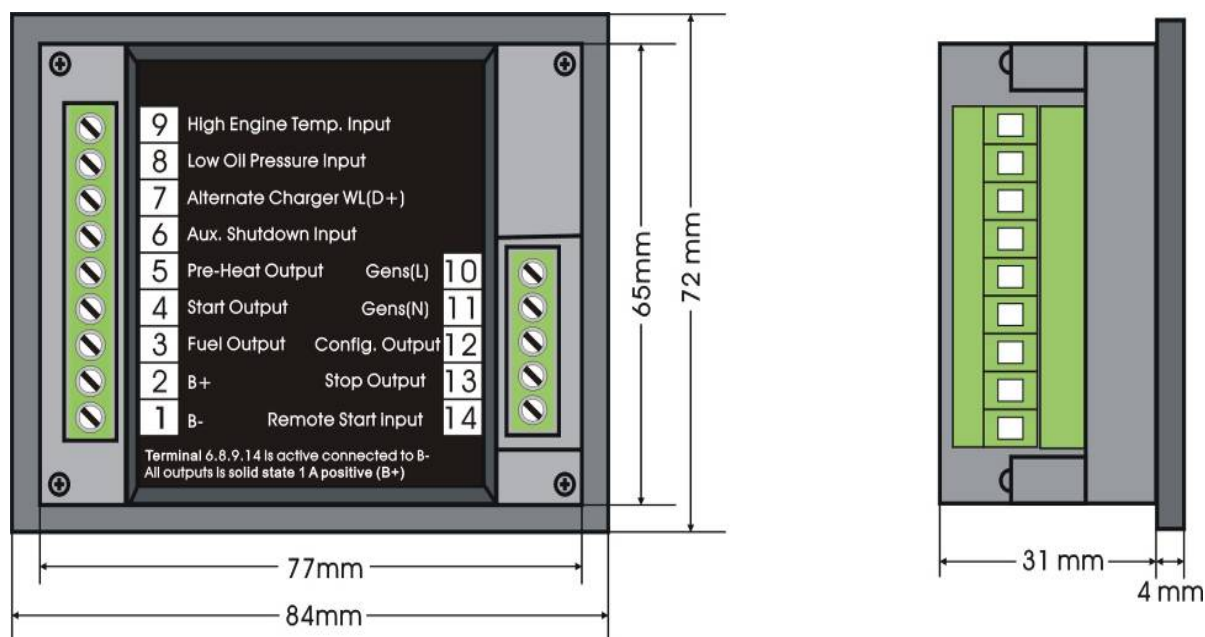

9. TYPICAL CONNECTIONS

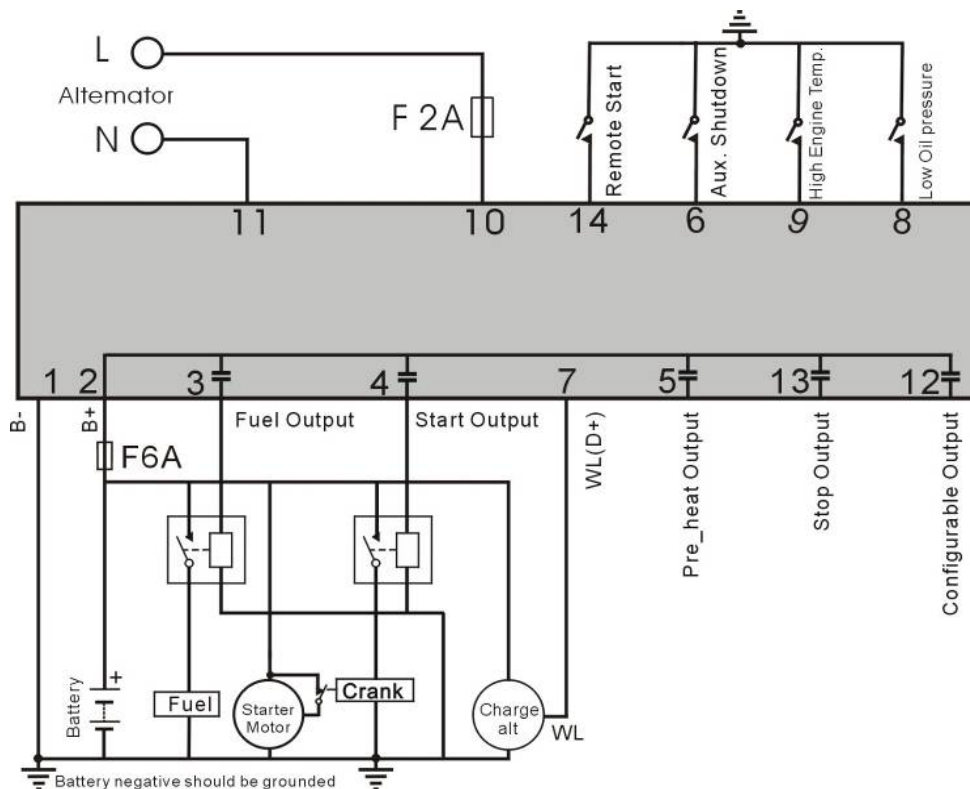

P.S.C. S.A.

Tres Arroyos 329, Haedo (1706) - Buenos Aires - Argentina

Tel.: (54-11) 4629-0600 / (54-11) 4483-3630 - Fax: (54-11) 4627-3500

www.cramelectro.com