



BI-FUEL SYSTEM



Control Unit

General Description

The ECO-D Bifuel system is designed to allow the functioning of Natural Gas Diesel engines (Dual), without the need of carrying out any changes in the engine characteristics because it remains within the Diesel cycle.

Gas goes in by the air filter back part and it is mixed with the already filtered air. The Gas air mixture goes into the combustion chamber and a small percentage of diesel fuel is injected by the pump and works as a pilot initiating combustion.

The quantity of Gas to go in will be in accordance with and proportional to the demands of the power the engine is subjected to and the temperature of combustion. The magnitude of these demands is taken through sensors that measure the reigning pressure in the admission multiple for turbo engines (in the case of normal aspiration engines they will register the movements of the injection pump accelerator) and the temperature of the exhaust gases. According to the information received on each of these values, the microprocessor will regulate the opening value of the doser valve. Furthermore, the control plate senses the temperature of the exhaust gases and whenever it exceeds a reestablished nominal value, the quantity of gas will be restricted in percentages set at the start up.

The control plate has a protection system against damages, that works in the case of engine high temperature, low oil pressure or obstruction in the air filter.

Specifications

Supply.....	12 / 24 Vcc.
PC Communication	RS 232
Weight Kg [Lb]	0.,200 [0,440]
Max. Manifold Air Pressure Inlet.....	1Kg/cm ²
Dimensions mm [In.]	130 x 175 x 30 [5,11 x 6,88 x 1,18]

Installation

The Electronic Control Unit (microprocessor) has to be mounted on a safe place, away from high temperatures, dust and liquids, to ensure correct functioning. To this purpose the control plate has to anchoring holes on its extremes to be mounted by means of screws in the corresponding panel or metallic cover(see diagram).

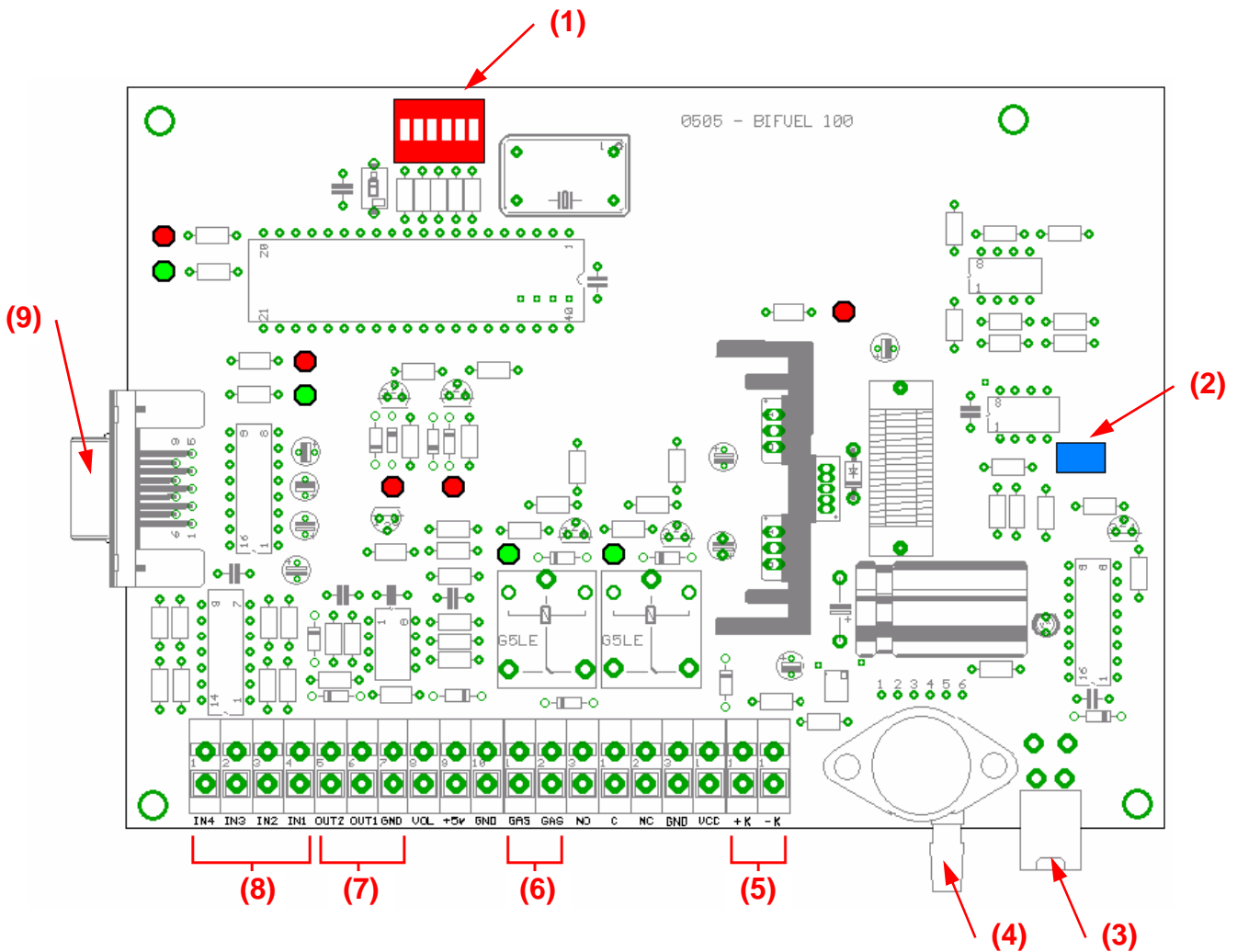

(1) DipSwitch of Selection:

1 - OFF - Pressure Out / ON - TPS In (Rheostat).

2 to 4 void (for future applications)

(2) Pressure gain adjusting:

By means of this potentiometer you can modify the pressure curve, you must verify the widest range at full load engine running.

(3) Step Motor Connector.

(4) Manifold air pressure Inlet



(5) Thermocouple Inlet (Temperature Sender):

The thermocouple registers the exhaust gas temperature. It is installed 15 cm over the turbocharger or exhaustion flange.

[+K]: Thermocouple (+) Polarity

[-K]: Thermocouple (-) Polarity

(6) [GAS]: N.O. contacts to manage the shut off gas solenoid valve.

The Shut Off Solenoid Valve must be mounted as the valve diagram indicates and its connection. This will allow the start of the engine with Diesel and after a given time the shut off gas solenoid will release the flow Gas to the system.

(7) Open Collector Transistor Outputs:

[OUT1]: System ON

[OUT2]: over temperature

(8) Inlets:

[IN4]: TPS In

[IN1] to [IN3] void (for future applications)

(9) RS232 Connector:

Warning

(+5V) only for external accessory power supply propose, do not connect +5V here.

Connection Diagram:

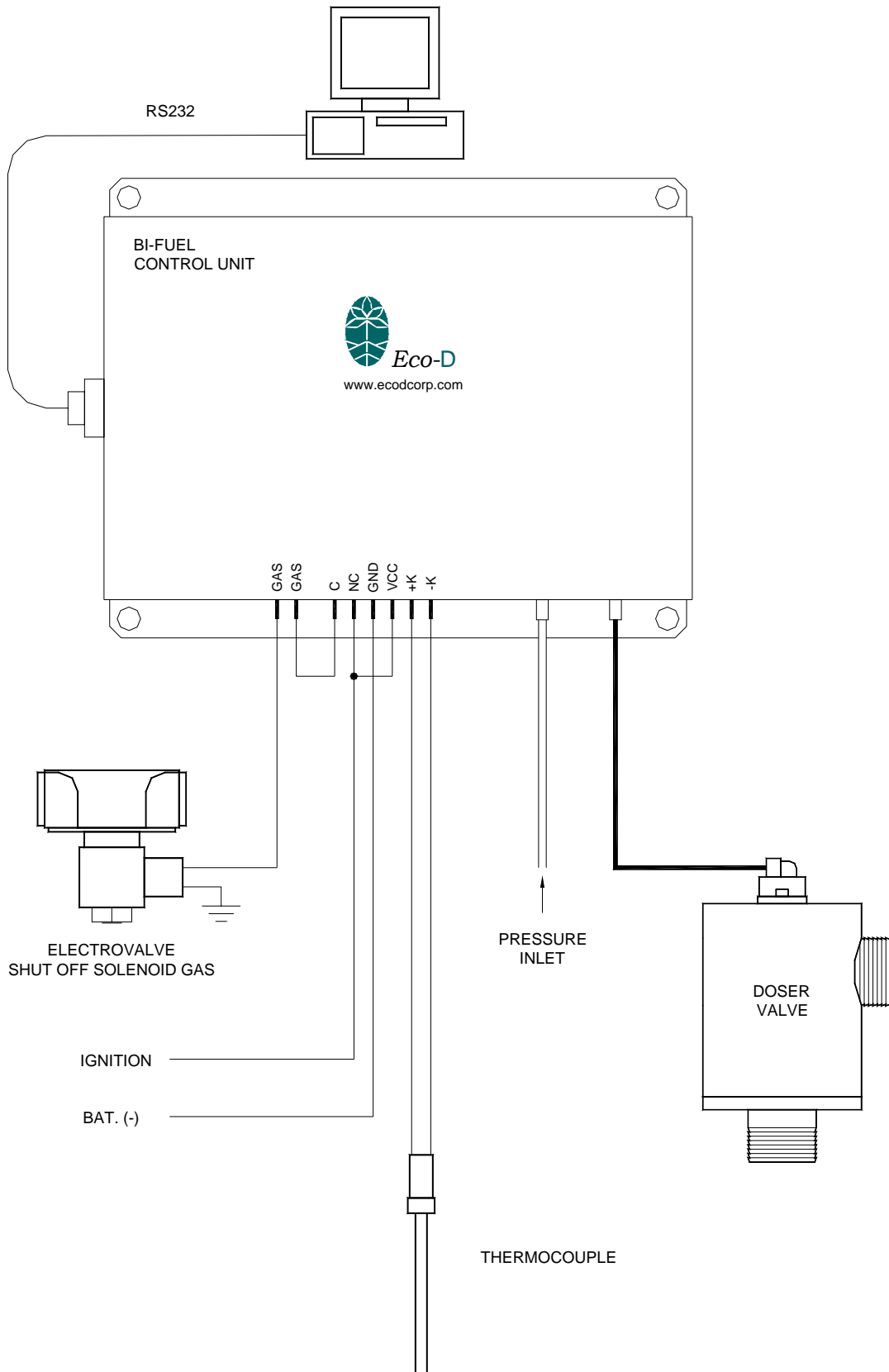

DOSER VALVE

Installation Dimensions

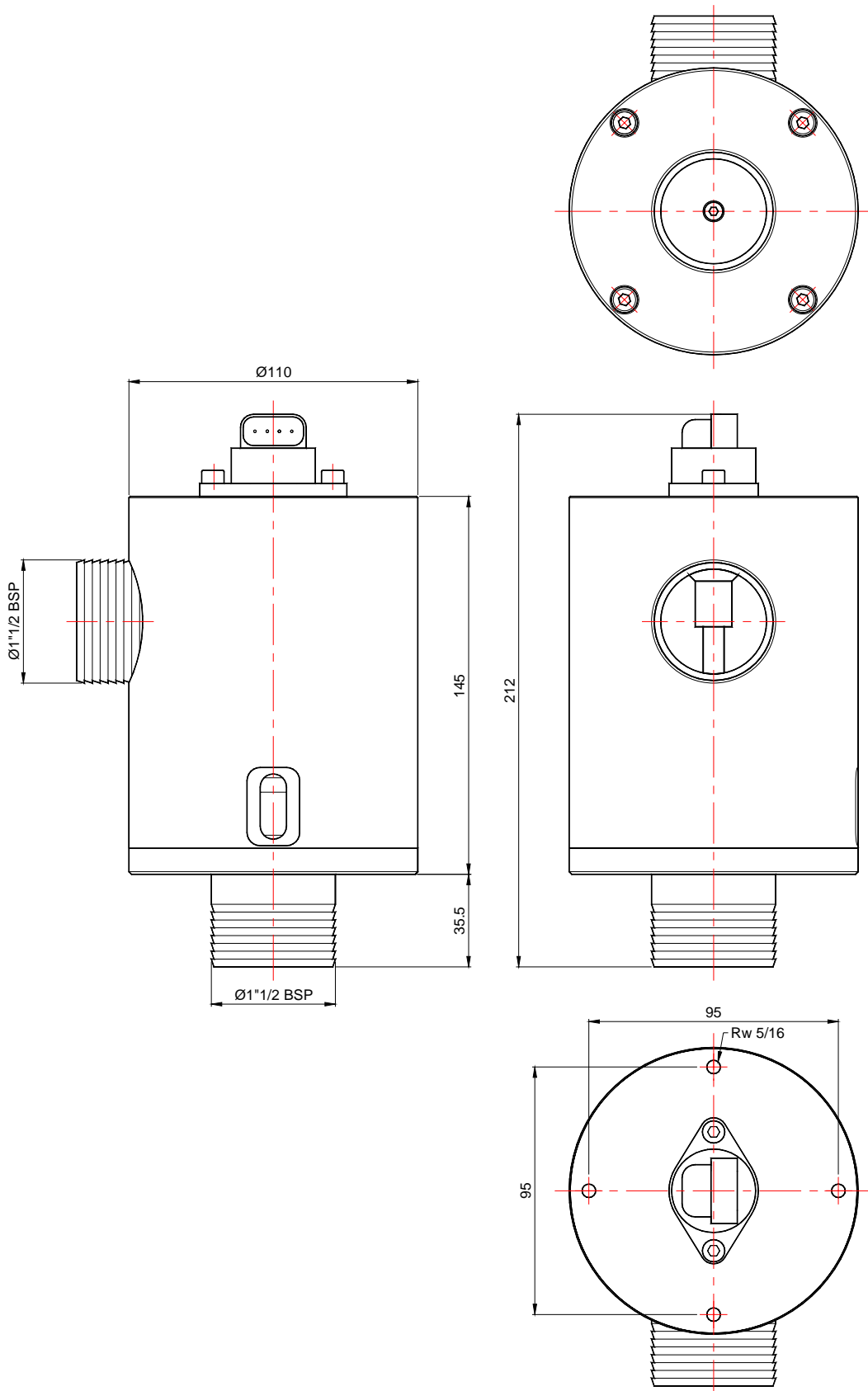

Weight Kg (Lb).....4,27 (9,41)

Installation

The installation must be carried out with the implementation of screws in the indicated position and of easy access. The mounting must be done in a free from liquid spills place, proximate to the air filter, taking into account that between the doser valve and the air filter, the maximum flow regulator is located. see valve diagram

Valve Diagrams

The Bi-fuel system requires the following elements for its proper functioning

Scheme for stationary application

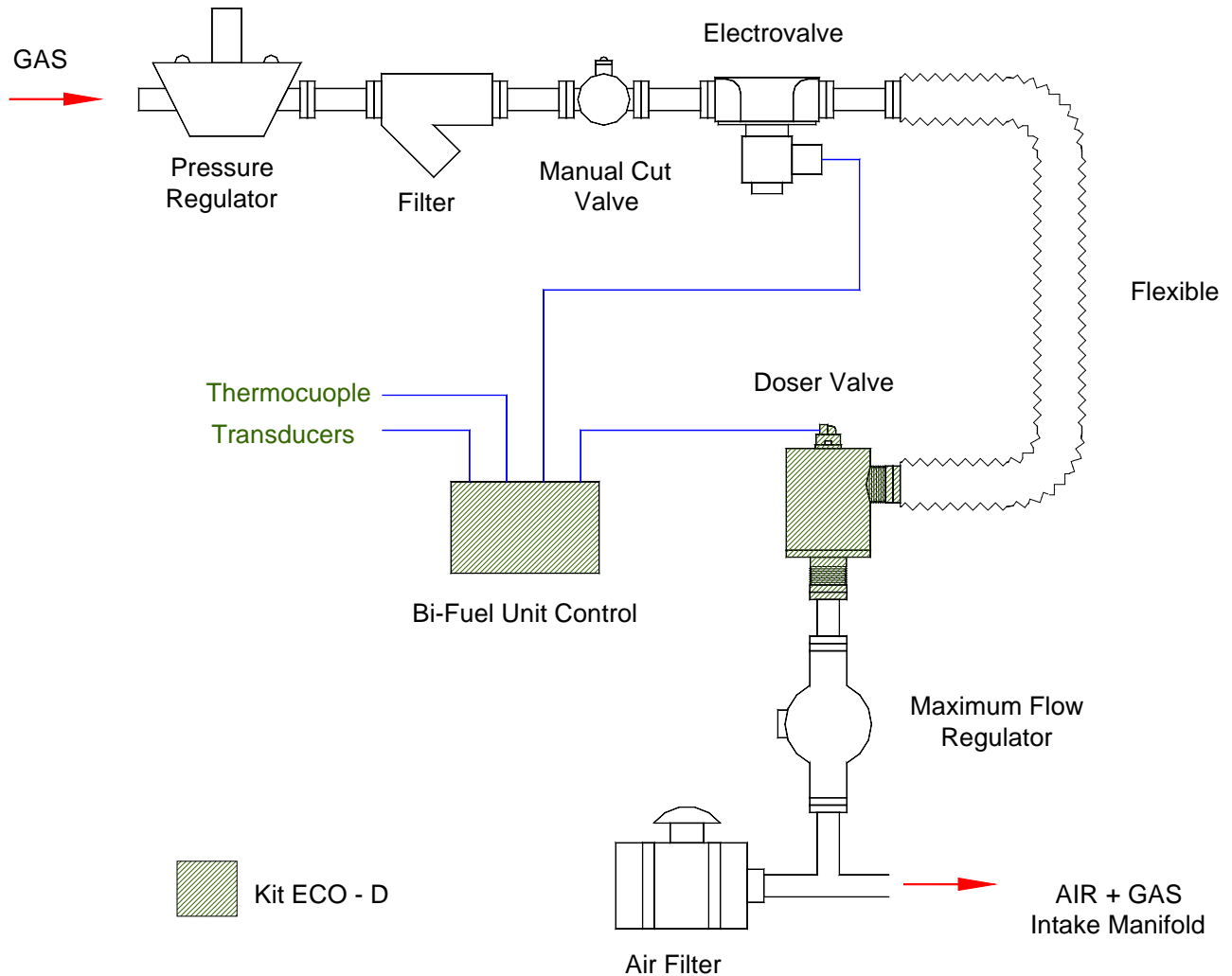

Scheme for s vehicle application

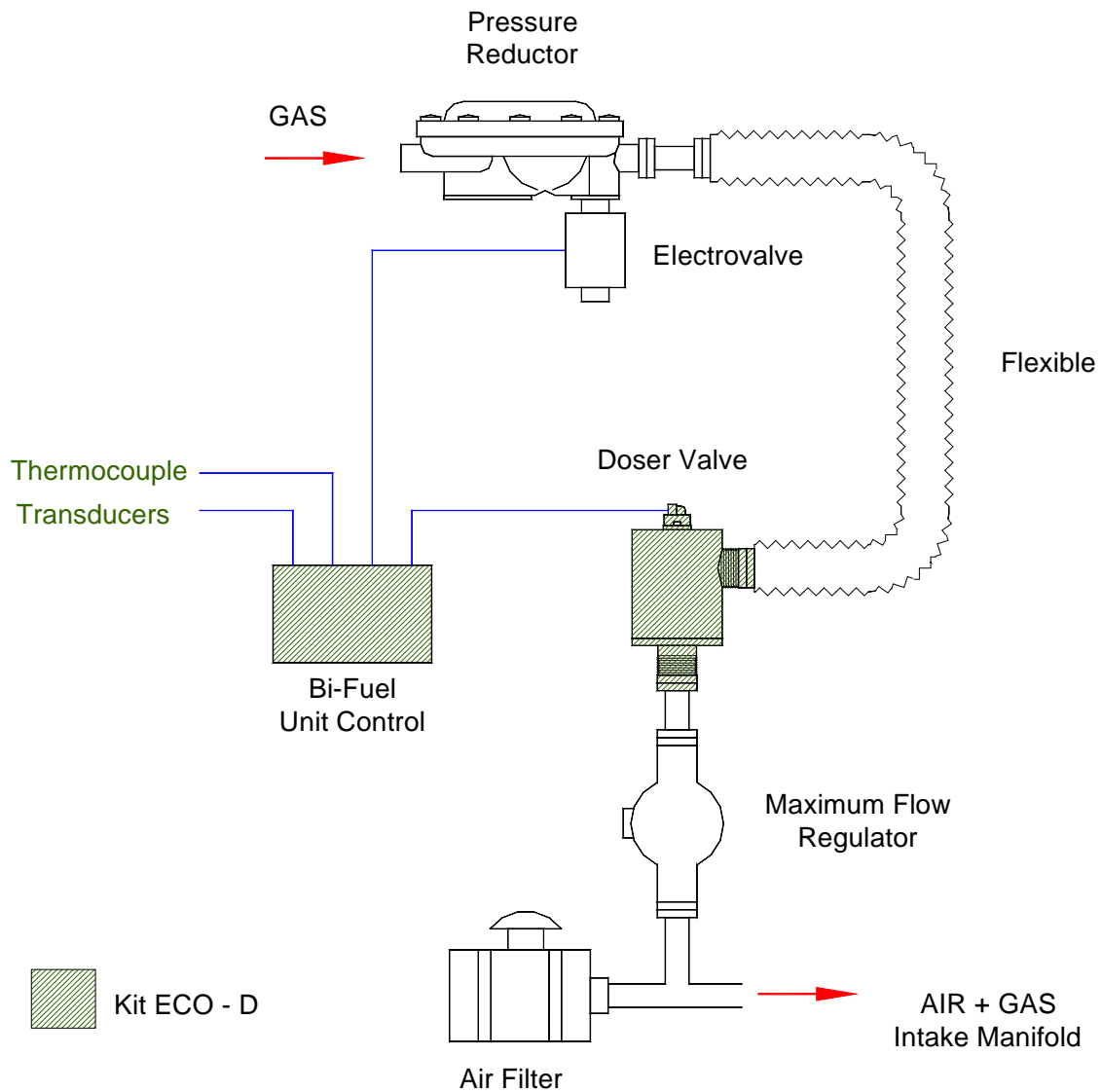

Start Up and Setting

Step 1: Installation of the Application.

To use this program for the first time, the installation of the application must be carried out initially. To do so the installer must be executed, with a double click on the “Installaldor Bifuel.exe” icon (Installer).

Then the instructions described in the dialogue chart must be followed, choose the version to install (English or Spanish) and files will be installed.

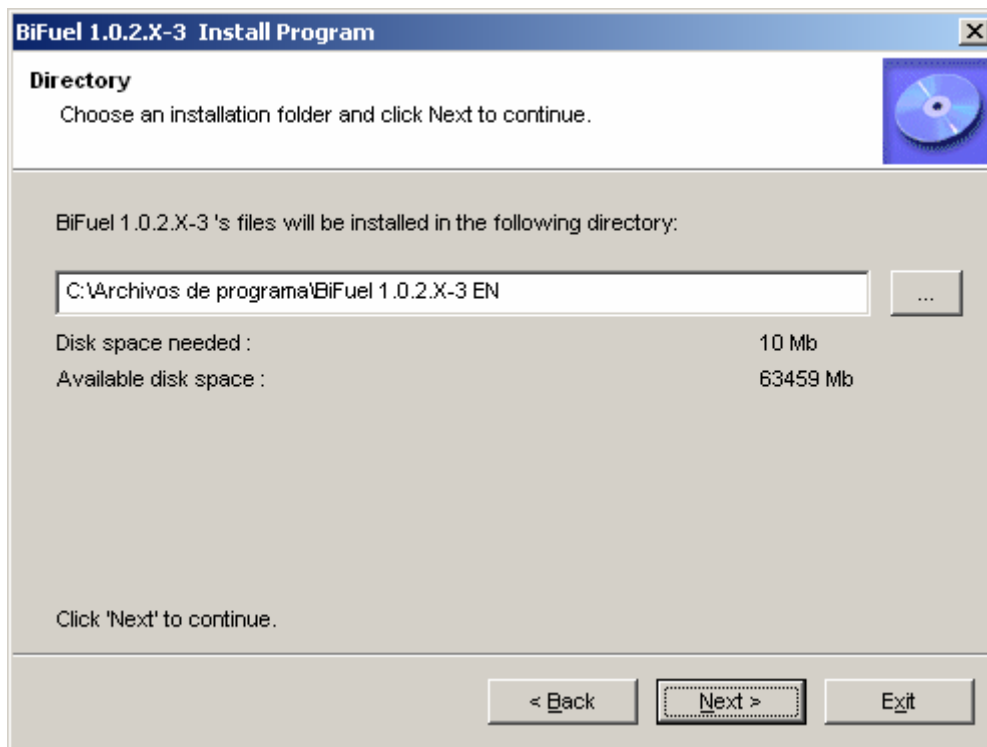

Step 2: Opening of the Application

Once such installation has been performed, the program can be opened through a double click on the “Control Bifuel” icon. Next the COM communication port between the control unit and the PC must be selected:



After the port is selected, the chart corresponding to the parameter selection appears:

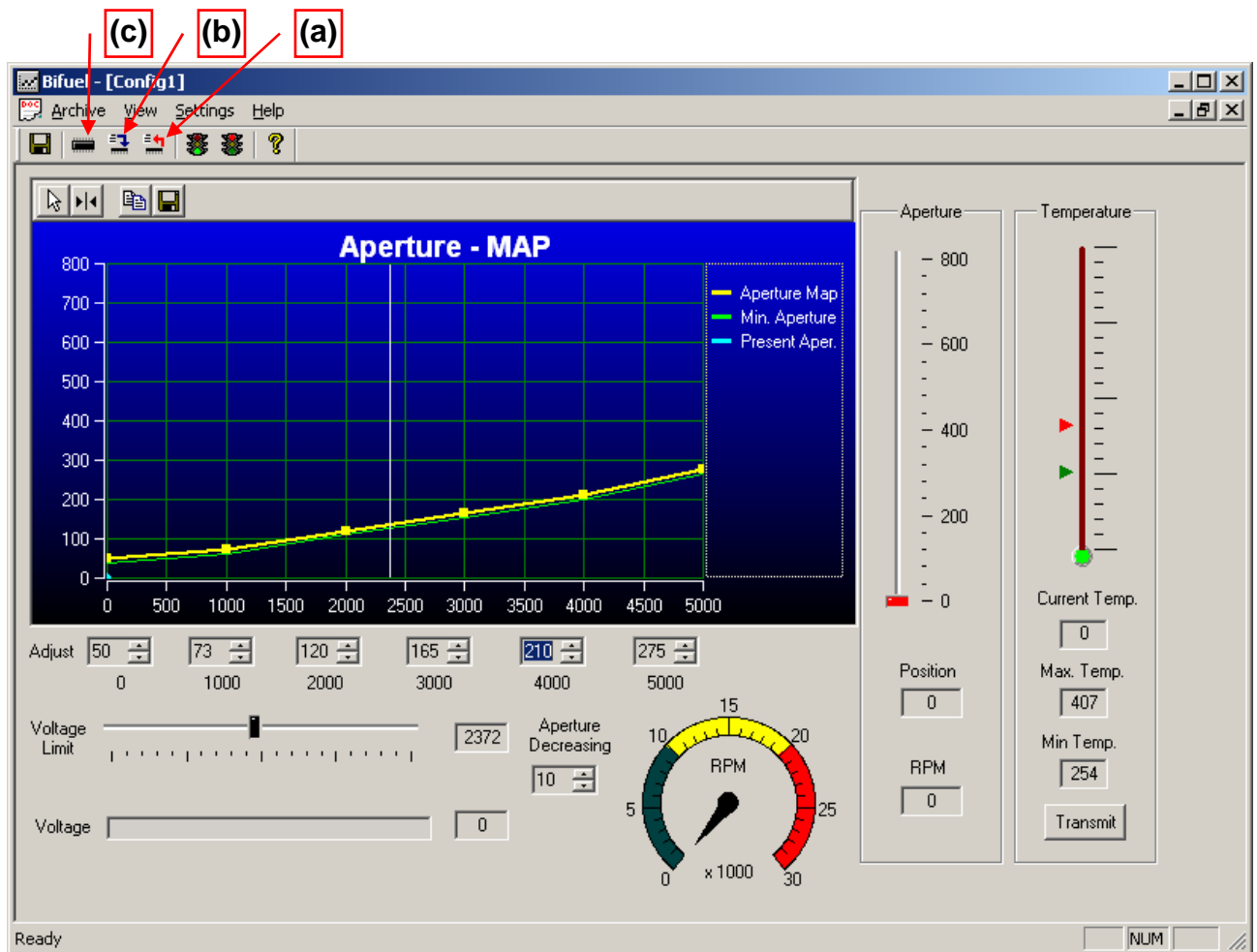

Step 3: Parameter Setting and Recording

Before loading any parameter, the connection between the control unit and the PC (with an RS232 wire) and with the other accessories that conform the system must be checked.

Firstly, the information from the control unit is received clicking once on the “upload from Microcontroller” (a) icon. Next, the values of the following parameters will be shown; adjustment points of the Opening vs. Voltage curve, temperatures (current, maximum and minimum) and voltage limit.

- **Adjustment Points:** The Opening vs. Voltage curve is defined by six adjustment points, which are variable according to the charge needs and rates.
- **Temperature:** the ranks of the current temperatures are established, the maximum and minimum defined, according to the thermocouple in the exhaust duct of the engine.
- **Voltage limit:** this parameter is delimited with a white vertical line over the Opening vs. Voltage curve. It establishes, according to the opening tension, the moment when the solenoid valve must open the gas flow to feed the system.

When a change in the value of these parameters is necessary, this task is carried out through the keyboard and the mouse.

After changing the value of six adjustment points, with a click on the “Transmit” icon the new values are activated. When the tension limit values are changed, with a click on the “Download to Microcontroller” (b) icon, the new value information is sent to the control unit. To record the new configuration in the microprocessor with the curve formed by the modified values, a double click on the “Program” icon must be performed (c).

To set the speed response of the flow engine of the doser valve, a click must be carried out on “Settings” / “Motor Speed” and the opening and shutting values must be set, as the diagram shows. A value of 5 is recommended for opening and shutting. (Please consult about other values)

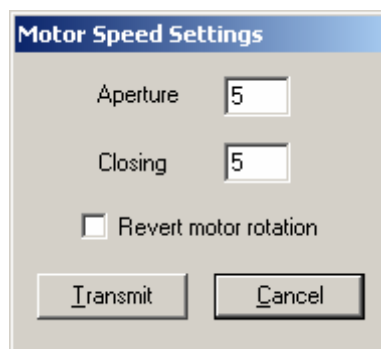

Finally, to be able to load this new configuration when required, a click on “Save” must be performed and the destination directory must be selected.

Eng. Ruben

ECO-D Products

ARGENTINA: Tres Arroyos 329
Haedo – Buenos Aires. T.E. (54-11) 4629 – 0600
E-Mail: cram@speedy.com.ar
Web: cramelectro.com

- NOTE -

Eco-D believes that all information provided herein is correct and reliable and reserves the right to update at any time. ECO-D does not assume any responsibility for its use unless other expressly undertaken