

***R4105***  
***Series***  
***Engines***

**O  
P  
E  
R  
A  
T  
I  
O  
N  
  
M  
A  
N  
U  
A  
L**



**NEW HOLLAND**

## Attention

1. The diesel engine operators must familiarize themselves with this manual as well as engine construction and strictly follow the procedures of operation and maintenance especially the regulations for safety operation described in this manual.
2. Before operating an engine at full load, the **60** hours running in should be carried out as specified in the manual.
3. Increase its speed gradually after starting a cold engine, never let it run at high speed abruptly, and don't stop the engine instantly while its cooling water is still hot, also don't let the engine running long time without load.
4. If the ambient temperature falls below  $+5^{\circ}\text{C}$ , drain the cooling water out of the radiator, the lubricating oil cooler and the diesel engine itself completely after stopping the engine. Continuous keeping the water in the oil cooler should be forbidden.
5. Never run the diesel engine without an air cleaner so as to prevent the unfiltered air from entering the cylinders.
6. The engine must be filled with specified grade fuel and lubricating oil, and a special and clean container for each oil should be used. The fuel oil should be settled for **72** hours and filtered before using.
7. The inspection and repair of the components in electrical system must be carried out by the person who has a good knowledge of electricity.
8. If the water pump is without oil filler, it's a ??? bearing water pump, and needn't add lub oil to it.
9. Be sure to use water – cooling diesel engine. Please refer to **P. 43** for details.
10. The working environment of the diesel engine should be well ventilated to avoid being polluted by waste gas or smoke.
11. The power rating and amending of the diesel engine is according to **GB6072.1 – 2000** the first section of reciprocating internal combustion engine; standard basic condition, the

rating and testing method of power, fuel consumption and engine oil consumption.

12. The manufacturing of the diesel engine is according to the common technical requirement for low and middle level powered diesel engine in JB/T8895 – 1999 and Q/WCG005 – 2002R series diesel engine enterprise standard.
13. The No. of production license of this series diesel engine is: XK06 – 205 – 00160, XK06 – 205 – 00161, XK06 – 205 -- 00279.
14. The position of safety warning marks:
  - (1) There's a guard against burning mark at the end of the cylinder cover which is beside the exhaust manifold of the diesel engine.
  - (2) There's a guard against fire mark at the oil filler.
  - (3) There's a guard against twinning mark on the inlet manifold.
  - (4) There's a flywheel rotating direction mark on the flywheel housing.

# Contents

1. Longitudinal sectional drawing for R4100, R4105 diesel engine (Fig. 1a) .....	1
Cross sectional drawing for R4100, R4105 diesel engine (Fig. 1b) .....	2
2. Longitudinal sectional drawing for R6100, R6105 diesel engine (Fig. 2a) .....	3
Cross sectional drawing for R6100, R6105 diesel engine (Fig. 2b) .....	4
3. Speed and speed adjusted characteristic curve for Model R4105, R4105Z diesel engine (Fig. 3) .....	5
4. Speed and speed adjusted characteristic curve for Model R6105, R6105Z diesel engine (Fig. 4) .....	6
5. Speed adjusted characteristic curve for Model R4105T and R4105T1 diesel engine for tractor usinn (Fig. 5) .....	7
6. Speed and speed adjusted characteristic curve for Model R4105G diesel engine used for engineering machine (Fig. 6) .....	8
7. Speed and speed adjusted characteristic curve for Model R6105G, R6105G1, R6105ZG and R6105ZG1 diesel engine used for engineering machine (Fig. 7) ...	9
8. Load characteristic curve for Model R6100ZD1 and R6100ZD2 diesel engine for generating sets (Fig. 8) .....	10
9. Propellant characteristic curve for Model R4105C, R4105C1, R6105C and R6105C1 marine diesel engine (Fig. 9) .....	11
10. Load characteristic curve for Model R4105P, R4105ZP and R6105P diesel engine for generating unit (Fig. 10) .....	12

## **CHAPTER I. Main Technical Specifications and Data for the diesel engine .....**

- § 1 Main technical specifications
- § 2 Range for various temperature and pressure
- § 3 Tightening torque of main bolts
- § 4 Main adjusting data
- § 5 Matxhed clearances and wear limit of main parts

## **CHAPTER II. Main structure of diesel engine .....**

- § 1 Cylinder head assembly
- § 2 Cylinder block and related assembly
- § 3 Camshaft assembly
- § 4 Piston and connecting rod assembly
- § 5 crankshaft and flywheel assembly

- § 6 Transmission system
- § 7 Intake and exhaust system
- § 8 Fuel system
- § 9 Lubricating system
- § 10 Cooling system
- § 11 Electric system
- § 12 Air compressor assembly
- § 13 Clutch assembly

**CHAPTER III. Operation of diesel engine ..... 54**

- § 1 Transportation, installation, storage and preservation
- § 2 Fuel, oil and cooling water
- § 3 Preparation before starting
- § 4 Starting
- § 5 Running
- § 6 Stopping
- § 7 The wearing in of the diesel engine
- § 8 Safe and technical operation rule

**CHAPTER IV. Technical maintenance of diesel engine ..... 61**

- § 1 Working day maintenance
- § 2 First grade technique maintenance
- § 3 Second grade technique maintenance
- § 4 Third grade technique maintenance
- § 5 Technique maintenance on winter working

**CHAPTER V. Trouble and remedy method ..... 63**

- § 1 Start failures
- § 2 Unsteady running
- § 3 Output is insufficient or drops suddenly
- § 4 Abnormal noise during engine operation
- § 5 Abnormal exhaust smoke
- § 6 Insufficient oil pressure
- § 7 Oil temperature too high
- § 8 The temperature of used cooling water too high
- § 9 Trouble in the injection pump
- § 10 Insufficient fuel supply of the fuel delivery pump
- § 11 Injector in trouble

- § 12 Governor in trouble
- § 13 Engine stops suddenly
- § 14 Charged dynamo out of order
- § 15 Starting motor be in trouble
- § 16 Governor in trouble
- § 17 Turbocharger in trouble
- § 18 Air compressor in trouble
- § 19 Clutch in trouble

**CHAPTER VI.** Installation instruction for diesel engine  
generating set ..... **76**

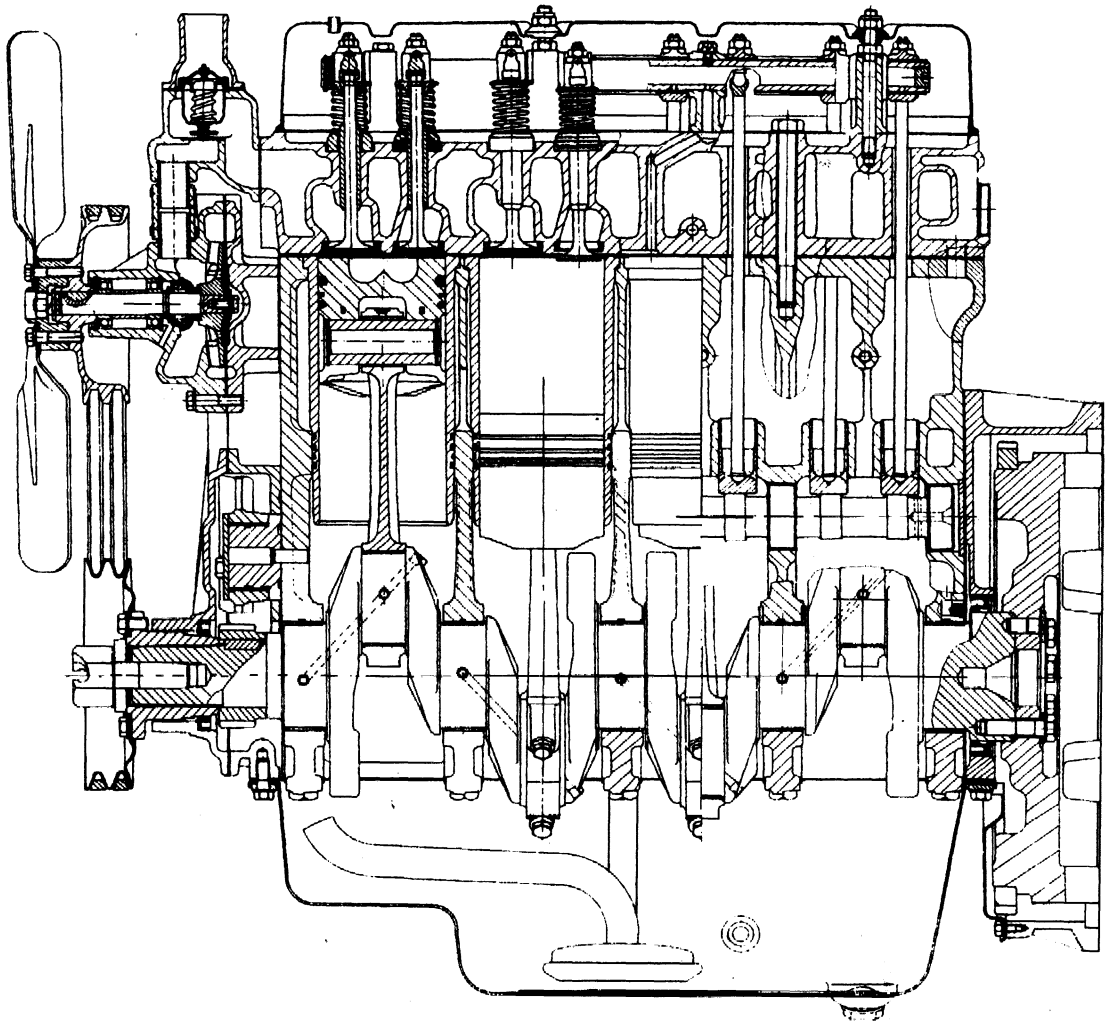

Fig. 1a Longitudinal sectional drawing for R4100, R4105 diesel engine

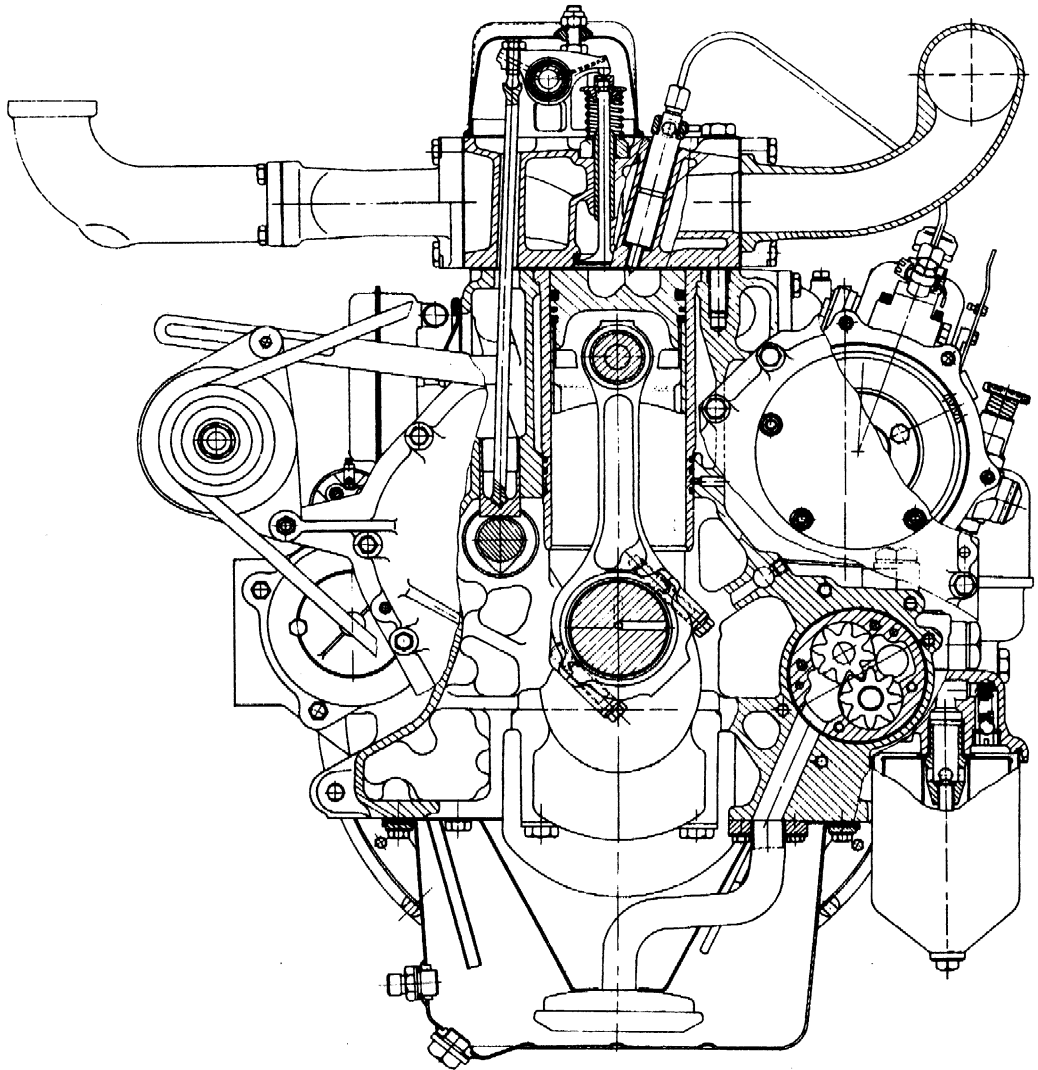

Fig. 1b Crsss sectional drawing for R4100 ,R4105 diesel engine



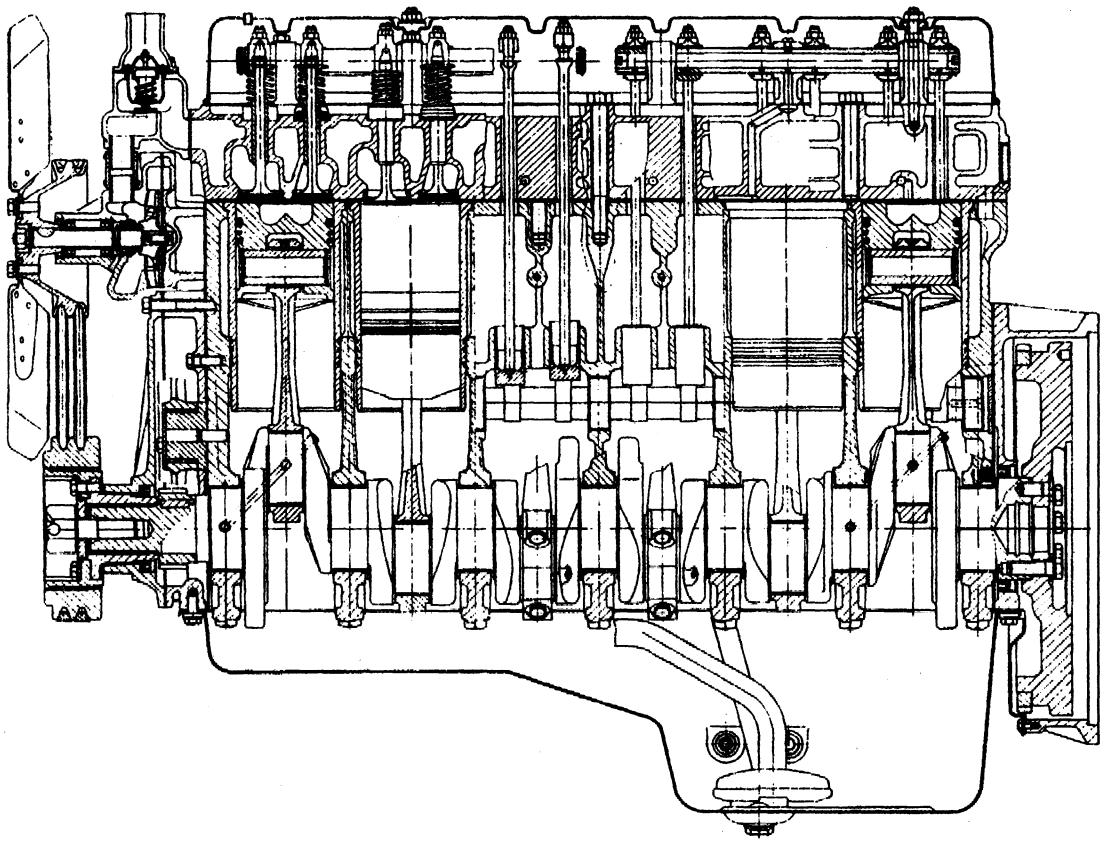

Fig. 2a longitudinal sectional drawing for R6100, R6105 diesel engine

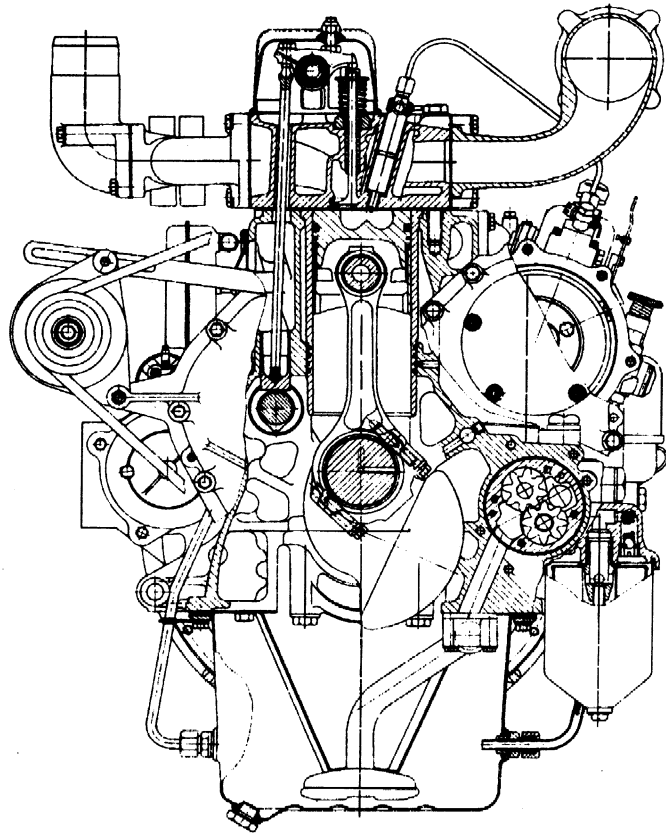

Fig. 2b Cross sectional drawing for R6100, R6105 diesel engine

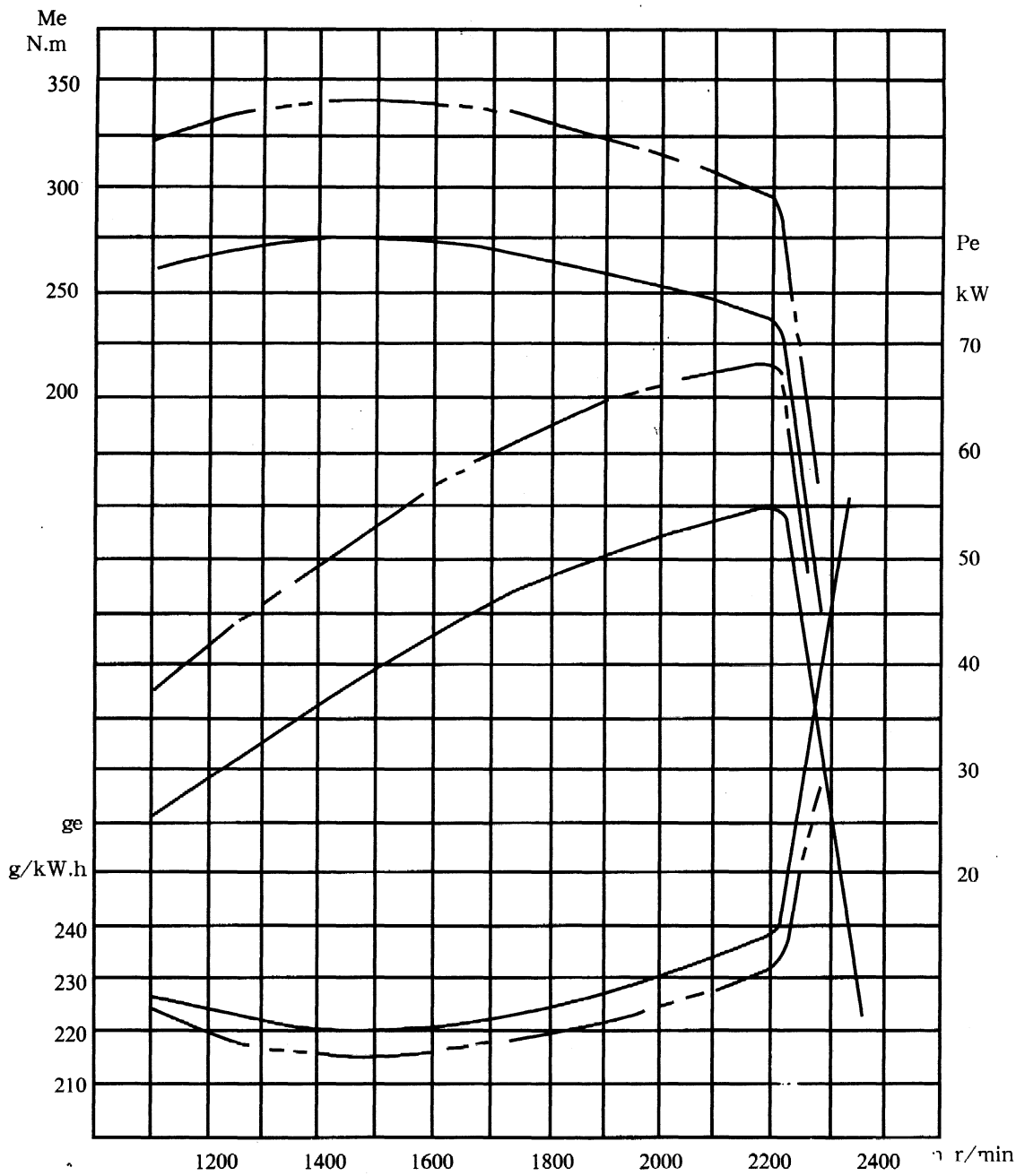

Fig. 3 Speed and speed adjusted characteristic curve for Model R4105, R4105Z diesel engine

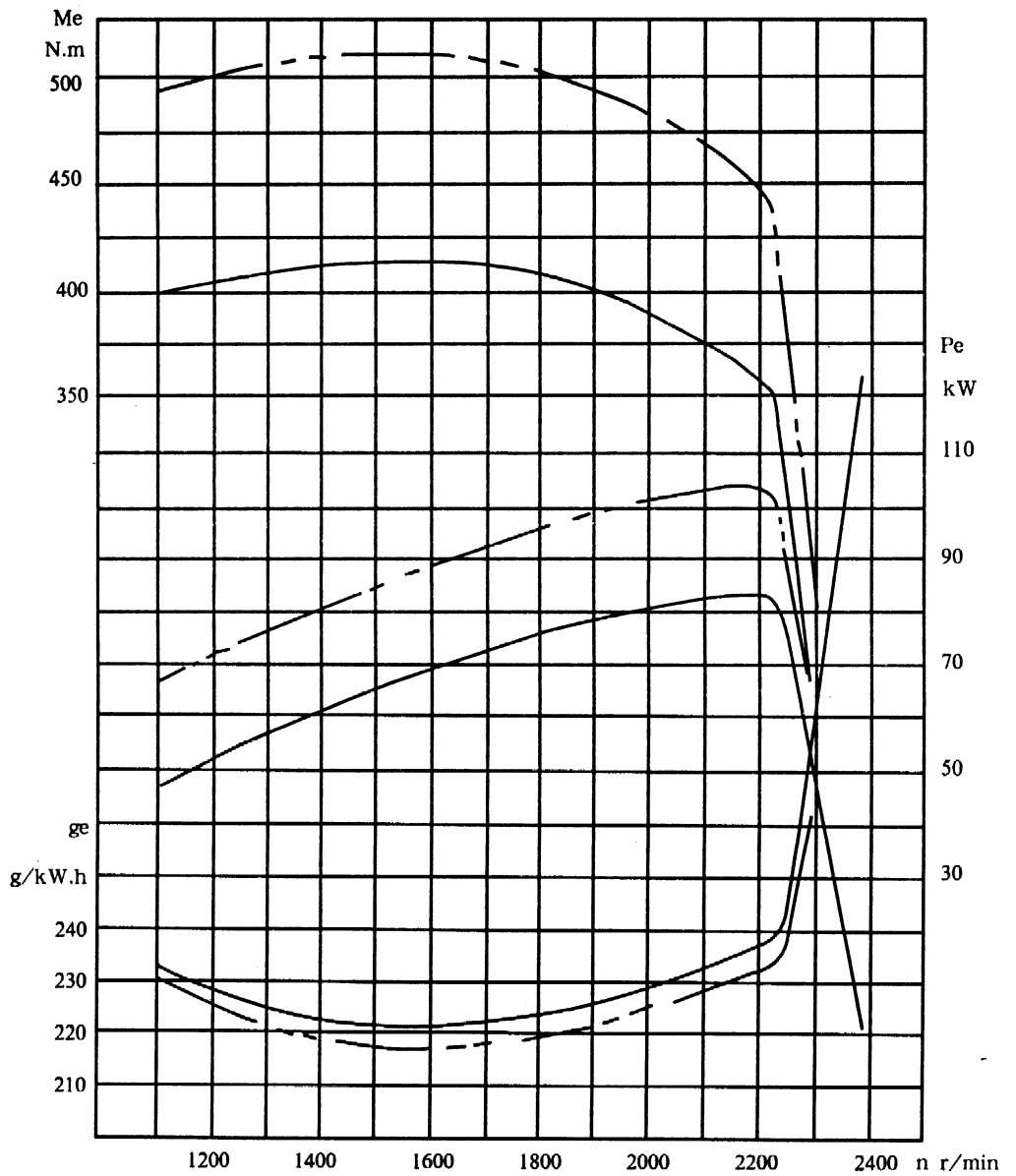

Fig. 4 Speed and speed adjusted characteristic curve for Model R6105, R6105Z diesel engine

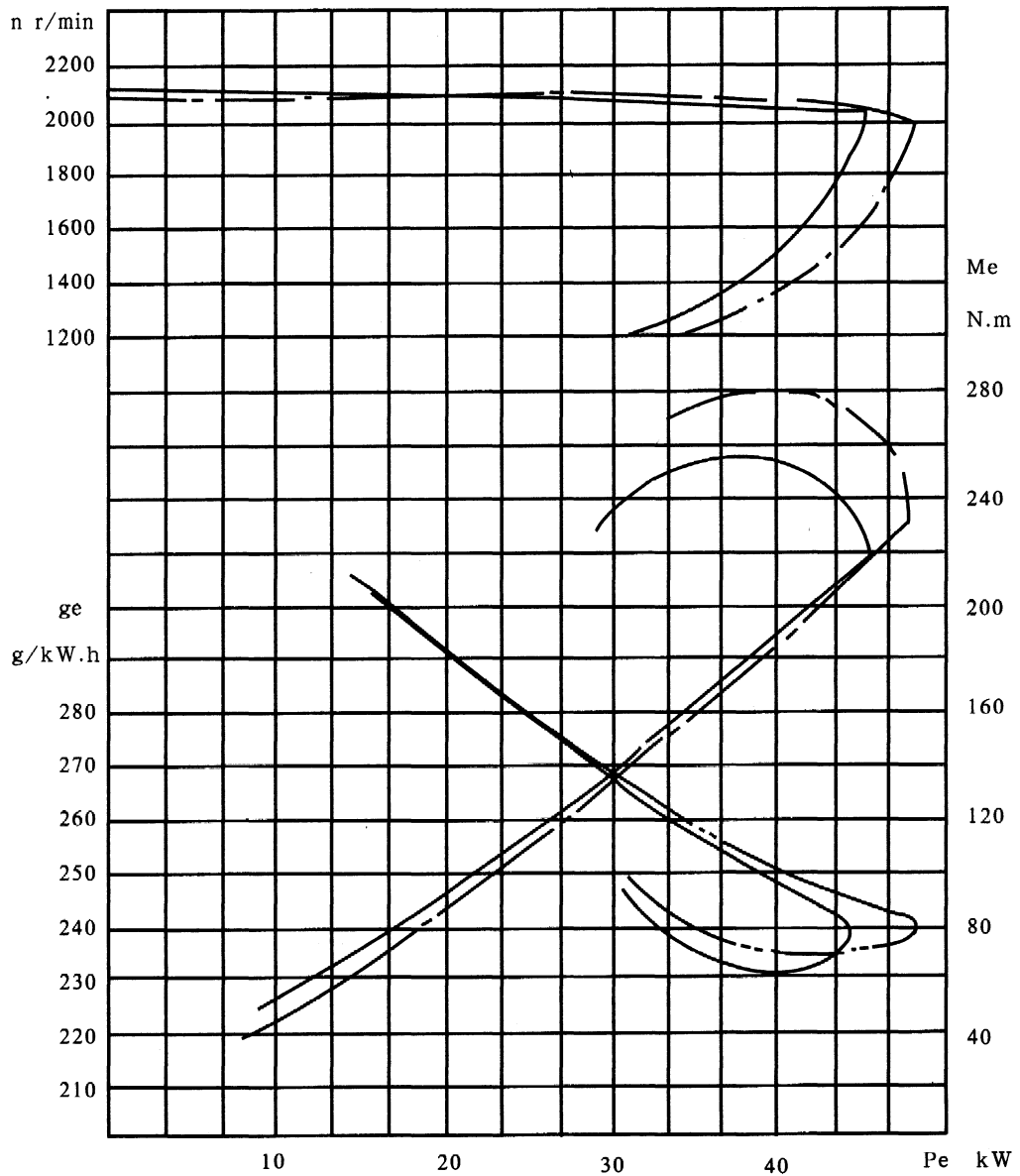

Fig. 5 Speed and speed adjusted characteristic curve for Model R4105T and R4105T1 diesel engine used for tractors

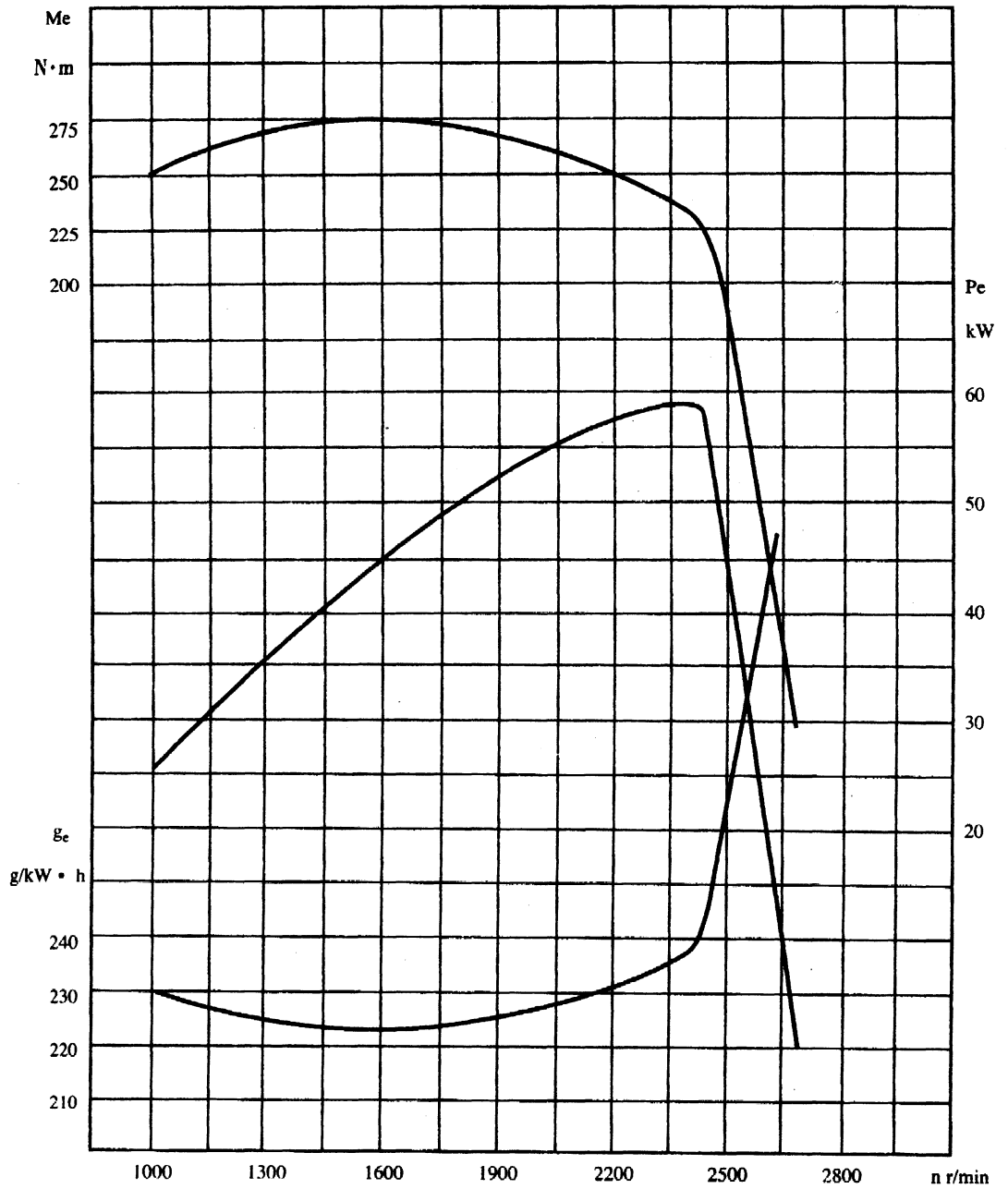

Fig. 6 Speed and speed adjusted characteristic curve for Model R4105G diesel engine used for engineering machine

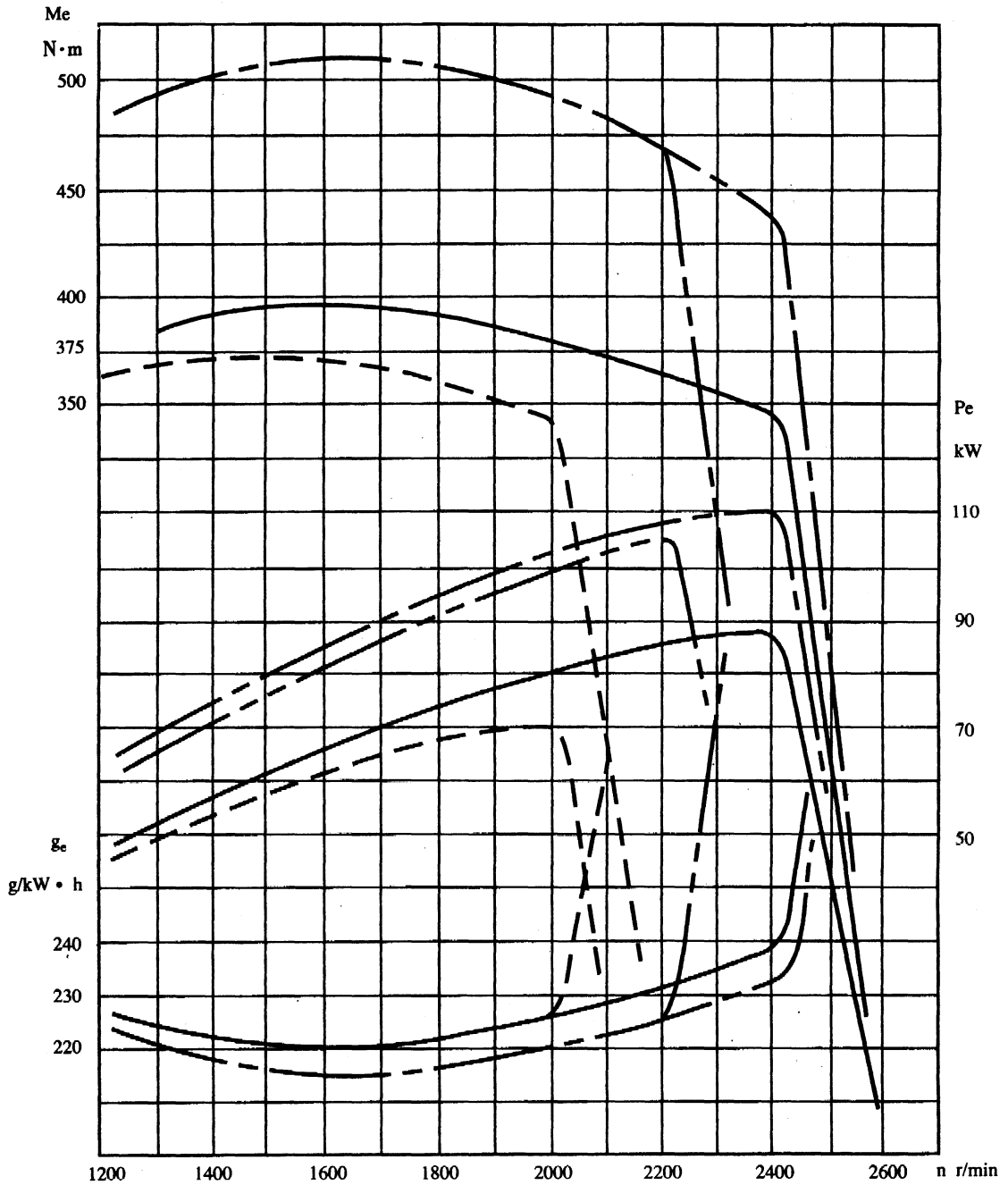

Fig. 7 Speed and speed adjusted characteristic curve for Model R6105G, R6105G1, R6105ZG and R6105ZG1 diesel engine used for engineering machine

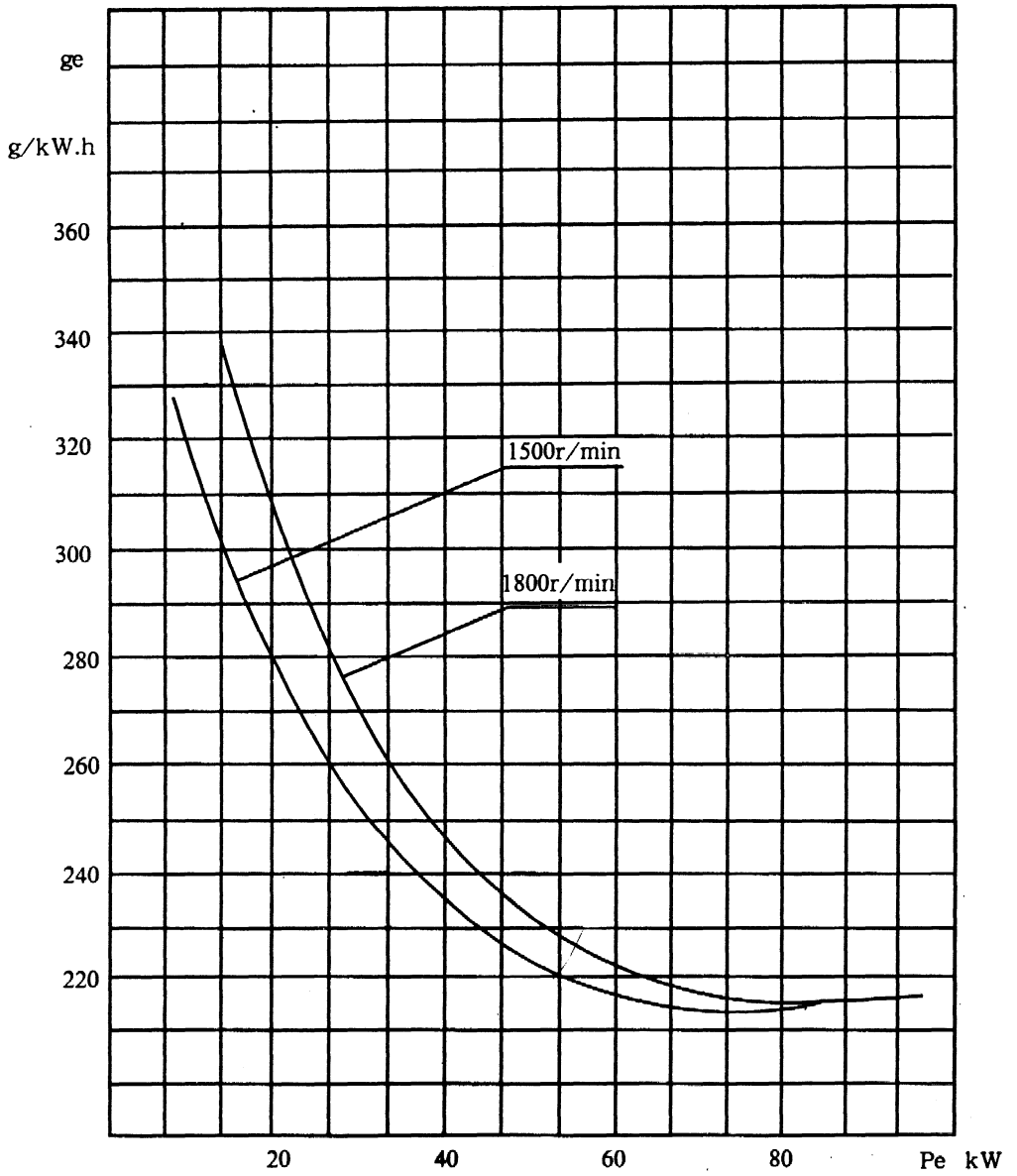

Fig. 8 Load characteristic curve for Model R6100ZD1 and R6100ZD2 diesel engine for generating sets



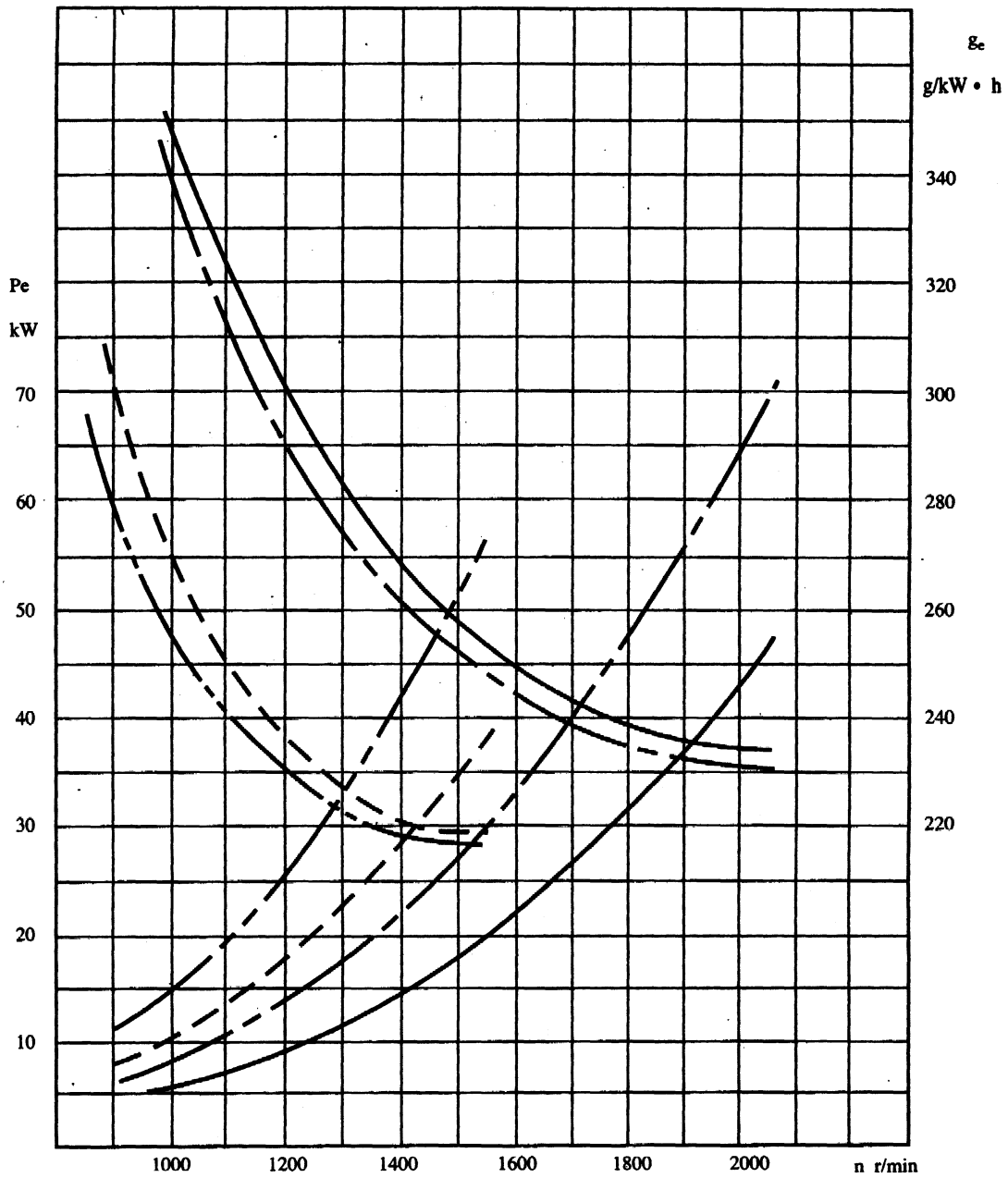

Fig. 9 Propellant characteristic curve for Model R4105C, R4105C1, R6105C and R6105C1 marine diesel engine

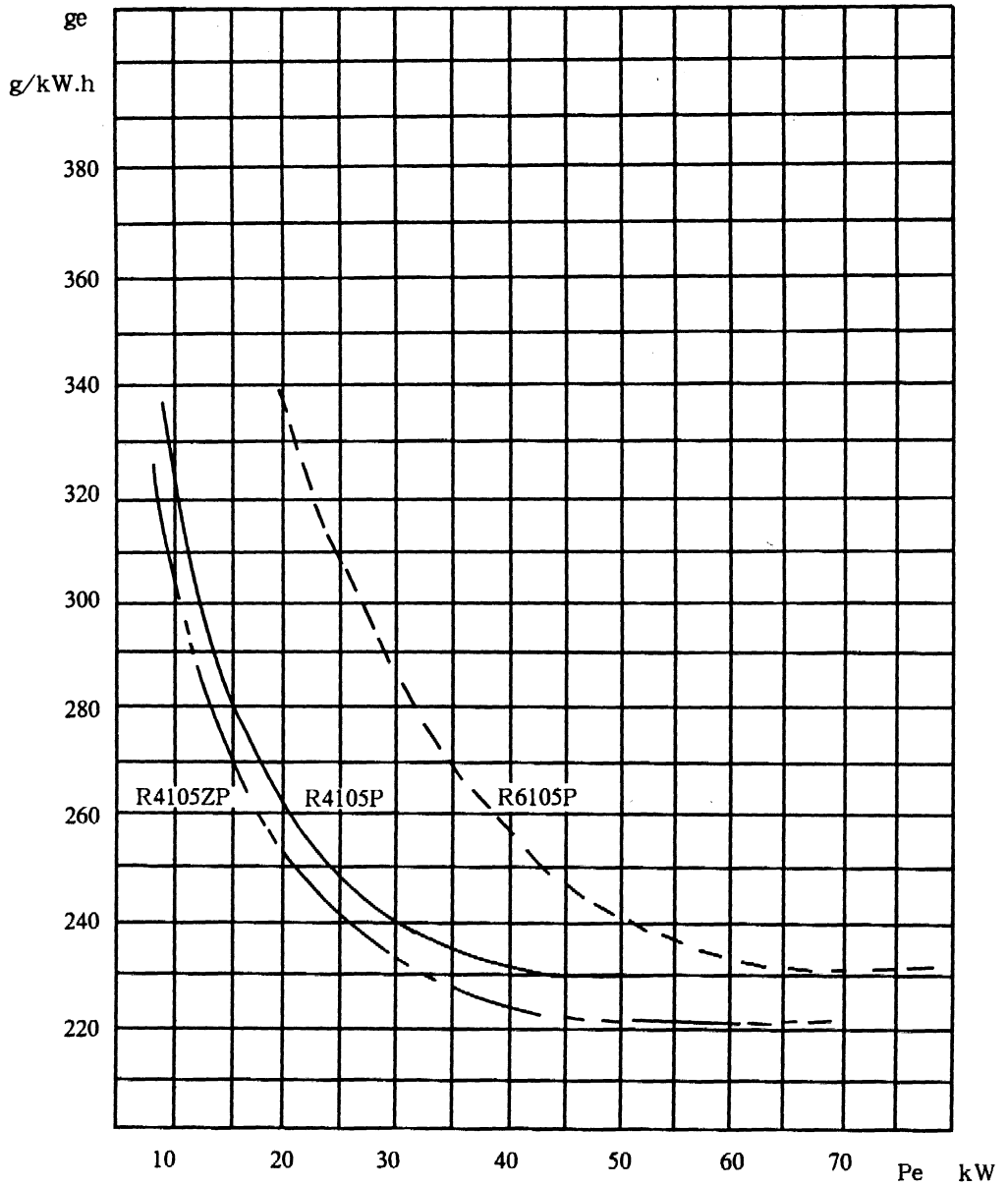

Fig. 10 Load characteristic curve for Model R4105P, R4105ZP and R6105P diesel engine for stationary power using

# CHAPTER 1 Main Technical Specifications and Data of Diesel Engine

## § 1 Main Technical Specifications

No.	Model		R4100D1	R4100D2	R4100ZD
	Item				
1	Type		Four strokes, Water Cooling, Inline, Direct injecting combustion chamber		
2	Cylinder No.—Bore x Stroke (mm)		4—100 x 125		
3	Total Displacement of Piston (L)		3.93		
4	Pressure Ratio		17:1		16:1
5	Firing Order		1—3—4—2		
6	Air Intake Mode		Naturally Aspirated		Turbocharged
7	Rated Working Condition	15min Output/Speed (KW/r/min)			
		1h Output/Speed (KW/r/min)			
		12H Output/Speed (KW/r/min)	36/1500	42/1800	47/1500
8	Highest Idling Speed (r/min)		≤1575	≤1890	≤1575
9	Lowest Idling Stable Speed (r/min)		≤600		
10	Max Torque/Speed (N * m/r/min)				
11	Rated Working Condition	Average Effective Pressure (Kpa)	733	712	957
12		Fuel Consumption Rate (g/KW * h)	≤231		≤224
13		Oil Consumption Rate (g/Kw * h)	≤1.63		
14		Exhaust temperature (°C)	≤600		
15	Crankshaft Rotating Direction		counter clockwise (Facing to the power output end)		
16	Cooling Mode		Forced Water Cooling		
17	Lubricating Mode		Compound type with pressure and splash		
18	Starting Mode		Electric starting		
19	Net Mass (kg)		420		490

R4100ZD1	R4100ZD2	R4105	R4105Z	R4105T	R4105T1	4105T6	No.
Four strokes, Water Cooling, Inline, Direct injecting combustion chamber							1
4—100 × 125		4—105 × 125					2
3.93		4.33					3
16:1		17:1	16:1	17:1			4
1—3—4—2							5
Turbocharged		Naturally Aspirated	Turbocharged	Naturally Aspirated			6
		55/2200	70/2200				7
47/1500	55/1800			45/2000	48/2000	48/2000	
≤1575	≤1890	≤2376		≤2160		≤2376	8
≤600							9
		275/1400	350/1600	252/1400	268/1500	246/1540	10
957	933	693	882	624	665	605	11
≤224		≤239	≤232	≤239			12
≤1.63							13
≤600							14
ounter clockwise (Facing to the power output end)							15
Forced Water Cooling							16
Compound type with pressure and splash							17
Electric starting							18
435		410	425	530			19

No.	Model		4105T7	4105T10	R4105ZT
			Item		
1	Type		Four strokes, Water Cooling, Inline, Direct injecting combustion chamber		
2	Cylinder No. —Bore × Stroke(mm)		4—105 × 125		
3	Total Displacement of Piston(L)		4.33		
4	Pressure Ratio		17:1	16:1	
5	Firing Order		1—3—4—2		
6	Air Intake Mode		Naturally Aspirated		Turbocharged
7	Rated Working Condition	15min Output/Speed(KW/r/min)			
		1h Output/Speed(KW/r/min)			
		12H Output/Speed(KW/r/min)	45/2000	50/2000	60/2200
8	Highest Idling Speed(r/min)		≤2160		≤2376
9	Lowest Idling Stable Speed(r/min)		≤600		
10	Max Torque/Speed(N * m/r/min)		265/1400	263/1500	300/1540
11	Rated Working Condition	Average Effective Pressure(Kpa)	665	693	756
12		Fuel Consumption Rate(g/KW * h)	≤239		≤232
13		Oil Consumption Rate(g/Kw * h)	≤1.63		
14		Exhaust temperature(°C)	≤600		
15	Crankshaft Rotating Direction		outer clockwise(Facing to the power output end)		
16	Cooling Mode		Forced Water Cooling		
17	Lubricating Mode		Compound type with pressure and splash		
18	Starting Mode		Electric starting		
19	Net Mass(kg)		530	550	

R4105G	R4105G8	R4105G20	R4105G25	R4105G31	R4105G28	R4105C	No.
Four strokes, Water Cooling, Inline, Direct injecting combustion chamber							1
4—105 × 125							2
4.33							3
17:1							4
1—3—4—2							5
Naturally Aspirated							6
							7
59/2400	60/2400	59/2400	59/2400	55/2400			
					50/2200	35/1500 ***	
2595 ~ 2688					≤2376	≤1700	8
≤600							9
270/1560	275/1560	270/1560	275/1680	250/1680			10
681	693	681	681	635	630	647	11
≤243			≤247	≤243	≤239	≤231	12
≤1.63							13
≤600							14
ounter clockwise( Facing to the power output end)							15
Forced Water Cooling							16
Compound type with pressure and splash							17
Electric starting							18
450	420	410	410	550	430		19

\*\*\* This volume is continual output.

No.	Model		R4105C1	R4105C5	R4105D1
	Item				
1	Type		Four strokes, Water Cooling, Inline, Direct injecting combustion chamber		
2	Cylinder No. —Bore × Stroke(mm)		4—105 × 125		
3	Total Displacement of Piston(L)		4.33		
4	Pressure Ratio		17:1		
5	Firing Order		1—3—4—2		
6	Air Intake Mode		Naturally Aspirated		
7	Rated Working Condition	15min Output/Speed(KW/r/min)			
		1h Output/Speed(KW/r/min)			
		12H Output/Speed(KW/r/min)	43/2000 ***	35/1500 ***	42/1500
8	Highest Idling Speed(r/min)		≤2200	≤1700	≤1575
9	Lowest Idling Stable Speed(r/min)		≤600		
10	Max Torque/Speed(N * m/r/min)				
11	Rated Working Condition	Average Effective Pressure(Kpa)	596	647	776
12		Fuel Consumption Rate(g/KW * h)	≤239	≤231	≤231
13		Oil Consumption Rate(g/Kw * h)	≤1.63		
14		Exhaust temperature(°C)	≤600		
15	Crankshaft Rotating Direction		ounter clockwise( Facing to the power output end)		
16	Cooling Mode		Forced Water Cooling		
17	Lubricating Mode		Compound type with pressure and splash		
18	Starting Mode		Electric starting		
19	Net Mass(kg)		430	530	420

R4105D2	R4105D4	R4105ZD1	R4105ZD4	R4105P	R4105L1	R4105L5	No.
Four strokes, Water Cooling, Inline, Direct injecting combustion chamber							1
4—105 × 125							2
4.33							3
17:1	16:1		17:1				4
1—3—4—2							5
Naturally Aspirated		Turbocharged		Naturally Aspirated			6
							7
46/1800	40/1500	56/1500	56/1500	48/2000	48/2000	48/2100	
≤1890	≤1575	≤1575	≤1575	≤2160	≤2200	≤2200	8
≤600							9
					258/1500	258/1500	10
708	739	1034	1034	665	665	633	11
≤231	≤231	≤231		≤239	≤242	≤242	12
≤1.63							13
≤600							14
ounter clockwise( Facing to the power output end)							15
Forced Water Cooling							16
Compound type with pressure and splash							17
Electric starting							18
420	430	435		550	410	410	19



No.	Model		R4105A	R4105AT	R4108A
	Item				
1	Type		Four strokes, Water Cooling, Inline, Direct injecting combustion chamber		
2	Cylinder No. —Bore × Stroke(mm)		4—105 × 130		4—108 × 130
3	Total Displacement of Piston(L)		4.5		4.76
4	Pressure Ratio		17:1		
5	Firing Order		1—3—4—2		
6	Air Intake Mode		Naturally Aspirated		
7	Rated Working Condition	15min Output/Speed(KW/r/min)			
		1h Output/Speed(KW/r/min)	57/2200	51.5/2200	60/2200
		12H Output/Speed(KW/r/min)			
8	Highest Idling Speed(r/min)		≤2376	≤2160	≤2376
9	Lowest Idling Stable Speed(r/min)		≤600		
10	Max Torque/Speed(N * m/r/min)		286/1400	301/1400	300/1400
11	Rated Working Condition	Average Effective Pressure(Kpa)	691	687	688
12		Fuel Consumption Rate(g/KW * h)	≤239		≤239
13		Oil Consumption Rate(g/Kw * h)	≤1.63		
14		Exhaust temperature(°C)	≤600		
15	Crankshaft Rotating Direction		counter clockwise(Facing to the power output end)		
16	Cooling Mode		Forced Water Cooling		
17	Lubricating Mode		Compound type with pressure and splash		
18	Starting Mode		Electric starting		
19	Net Mass(kg)		410	530	410

R6105	R6105Z	R6105G	R6105G5	R6105G8	R6105G10	R6105G12	No.
Four strokes, Water Cooling, Inline, Direct injecting combustion chamber							1
6—105 × 125							2
6.49							3
17:1	16:1	17:1					4
1—5—3—6—2—4							5
Naturally Aspirated	Turbocharged	Naturally Aspirated					6
							7
82/2200	105/2200	85/2400	81/2400	85/2400	81/2300	82/2200	
≤2376	≤2376	2592 ~ 2688			2484 ~ 2576	2376 ~ 2420	8
≤600							9
410/1400	525/1600	390/1680	375/1650	380/1680	377/1610	410/1560	10
689	882	655	624	655	651	689	11
≤239	≤232	≤243					12
≤1.63							13
≤600							14
ounter clockwise (Facing to the power output end)							15
Forced Water Cooling							16
Compound type with pressure and splash							17
Electric starting							18
520	540	540	530	540	560	560	19

No.	Model		R6105G20	R6105T	R6105C
	Item				
1	Type		Four strokes, Water Cooling, Inline, Direct injecting combustion chamber		
2	Cylinder No.—Bore × Stroke(mm)		6—105 × 125		
3	Total Displacement of Piston(L)		6.49		
4	Pressure Ratio		17:1		
5	Firing Order		1—5—3—6—2—4		
6	Air Intake Mode		Naturally Aspirated		
7	Rated Working Condition	15min Output/Speed(KW/r/min)			
		1h Output/Speed(KW/r/min)	85/2600		
		12H Output/Speed(KW/r/min)		80/2300	52/1500 ***
8	Highest Idling Speed(r/min)		≤2860	≤2484	≤1700
9	Lowest Idling Stable Speed(r/min)		≤600		
10	Max Torque/Speed(N * m/r/min)		380/1820	389/1725	
11	Rated Working Condition	Average Effective Pressure(Kpa)	604	643	641
12		Fuel Consumption Rate(g/KW * h)		≤243	≤241
13		Oil Consumption Rate(g/Kw * h)	≤1.63		
14		Exhaust temperature(°C)	≤600		
15	Crankshaft Rotating Direction		ounter clockwise( Facing to the power output end)		
16	Cooling Mode		Forced Water Cooling		
17	Lubricating Mode		Compound type with pressure and splash		
18	Starting Mode		Electric starting		
19	Net Mass(kg)		550	560	530

\*\*\* This volume is continual output.

R6105C1	R6105C8	R6105ZC2	R6105P	R6105D1	R6105D2	R6105ZD1	No.
Four strokes, Water Cooling, Inline, Direct injecting combustion chamber							1
6—105 × 125							2
6.49							3
17:1	16:1	17:1			16:1		4
1—5—3—6—2—4							5
Naturally Aspirated		Turbocharged	Naturally Aspirated			Turbocharged	6
							7
65/2000 ***	53/1500 ***	88/2000 ***	72/2000	58/1500	68/1800	84/1500	
≤2200	≤1700	≤2266	≤2160	≤1575	≤1890	≤1575	8
≤600							9
							10
601	653	814	665	715	698	1035	11
≤239	≤231	≤239	≤239	≤231	≤231	≤224	12
≤1.63							13
≤600							14
ounter clockwise( Facing to the power output end)							15
Forced Water Cooling							16
Compound type with pressure and splash							17
Electric starting							18
530	580	660	525	525	570		19

No.	Model		R6105ZD4	R6105ZLD	R6105ZG
			Item		
1	Type		Four strokes, Water Cooling, Inline, Direct injecting combustion chamber		
2	Cylinder No. —Bore × Stroke(mm)		6—105 × 125		
3	Total Displacement of Piston(L)		6.49		
4	Pressure Ratio		16:1		
5	Firing Order		1—5—3—6—2—4		
6	Air Intake Mode		Turbocharged	Turbocharged Intercooled	Turbocharged
7	Rated Working Condition	15min Output/Speed(KW/r/min)			
		1h Output/Speed(KW/r/min)			110/2400
		12H Output/Speed(KW/r/min)	75/1500	100/1500	
8	Highest Idling Speed(r/min)		≤1575	≤1575	2592 ~ 2688
9	Lowest Idling Stable Speed(r/min)		≤600		
10	Max Torque/Speed(N * m/r/min)				510/1600
11	Rated Working Condition	Average Effective Pressure(Kpa)	924	1232	847
12		Fuel Consumption Rate(g/KW * h)	≤224	≤218	≤236
13		Oil Consumption Rate(g/Kw * h)	≤1.63		
14		Exhaust temperature(℃)	≤600		
15	Crankshaft Rotating Direction		ounter clockwise( Facing to the power output end)		
16	Cooling Mode		Forced Water Cooling		
17	Lubricating Mode		Compound type with pressure and splash		
18	Starting Mode		Electric starting		
19	Net Mass(kg)		570	620	560

R6105Q	R6105Q1	r6105ZQ	R6105ZLQ	R6105A	R6108A	R6105B	No.
Four strokes, Water Cooling, Inline, Direct injecting combustion chamber							1
6—105 × 125				6—105 × 130	6—108 × 130	6—105 × 120	2
6.49				6.75	7.14	6.23	3
17:1		16:1		17:1			4
1—5—3—6—2—4							5
Naturally Aspirated		Turbocharged			Naturally Aspirated		6
103/2800	96/2800	125/2600	147/2600			110/3000	7
				85/2200	90/2200		
≤3080	≤3080	≤2860	≤2860	≤2376	≤2376	≤3300	8
≤600							9
400/1800	390/1800	520/1700	621/1700	424/1400	451/1400	403/1950	10
680	634	889	1045	714	688	706	11
≤230 *	≤230 *	≤224 *	≤210 *	≤239	≤239	≤230 *	12
0.8% * *				≤1.63	≤1.63	0.8% * *	13
≤600							14
ounter clockwise (Facing to the power output end)							15
Forced Water Cooling							16
Compound type with pressure and splash							17
Electric starting							18
550		565		520	520	550	19

§2 Various temperature and pressure range

Lub oil temperature	≤95°C (the TC Engine ≤105°C)
Outlet cooling water temperature	≤90°C
Lub oil pressure	0.30 ~ 0.50MPa ≥0.01MPa, when at idling speed
Fuel injection pressure	20 + 1.0MPa

§3 Main bolts tightening torque

Cylinder head bolt	180 ± 10N * m
Main bearing bolt	210 ± 10N * m
Flywheel bolt	210 ± 10N * m
Connecting rod bolt	120 ± 10N * m
Rocker arm bracket bolt	50 ± 5N * m
Crankshaft belt pulley bolt	230 ± 10N * m
Injector tightening nut	80 ± 10N * m

§4 Main adjusting data

Valve lash( cold state)	
Air intake valve	0.30—0.40mm
Exhaust valve	0.40—0.50mm
Valve timing: (crankshaft rotating angle) Air intake valve open Air intake valve close Exhaust valve open Exhaust valve close	12°before top dead center 38°after bottom dead center 55°before bottom dead center 12°after tope dead center
Compression Clearance	1—1.2mm
Fuel delivery advance angle: 1500—2200 r/min 2300—2500 r/min 2600—2800 r/min	17° ± 1°before top dead center 19° ± 1°before top dead center 18° ± 1°before top dead center

**NOTE:** The injector of vehicle diesel engine should adopt fuel delivery advancer

§ 5 Matched clearances and wear limit of main parts

No	Matched parts	Standard size	Matched clearance	Wear limit	
1	Crankshaft main journal neck and main bearing	Shaft $\Phi 85_{-0.020}^0$ Hole $\Phi 85_{+0.04}^{+0.086}$	0.040 ~ 0.106	0.30	
2	Crankshaft axle clearance		0.13 ~ 0.28	0.4	
3	Crankshaft & connecting rod journal neck and connecting bearing	Shaft $\Phi 72_{-0.020}^0$ Hole $\Phi 72_{+0.04}^{+0.075}$	0.040 ~ 0.095	0.30	
4	Connecting rod big end and crank	Shaft $\Phi 35_{-0.200}^{-0.100}$ Hole $\Phi 72_{+0.100}^{+0.200}$	axile clearance 0.200 ~ 0.400	0.70	
5	Piston skirt and cylinder liner	common piston	shaft $\Phi 10_{-0.15}^{-0.11}$	0.11 ~ 0.175	0.30
			Hole $\Phi 10_{+0.025}^0$		
		steel inlaid piston	shaft $\Phi 105_{-0.066}^{-0.046}$	0.11 ~ 0.175	0.30
			Hole $\Phi 10_{+0.025}^0$		
			shaft $\Phi 10_{-0.066}^{-0.046}$	0.046 ~ 0.091	0.15
Hole $\Phi 105_{-0.066}^{-0.046}$	0.046 ~ 0.091	0.15			
		Hole $\Phi 10_{+0.025}^0$			
6	Piston pin and connecting rod bushing	Shaft $\Phi 36_{-0.003}^{+0.002}$ Hole $\Phi 36_{+0.027}^{+0.047}$	0.025 ~ 0.050	0.15	
7	Piston pin and piston pin seat hole	Shaft $\Phi 36_{-0.003}^{+0.002}$ Hole $\Phi 36_{+0.008}^{+0.027}$	-0.002 ~ 0.0011	0.05	
8	The first compression ring and ring grave		0.065 ~ 0.105	0.40	
9	the second compression ring and ring gra		0.040 ~ 0.080	0.30	
10	oil ring and ring grave		0.045 ~ 1.080	0.25	
11	Gap of first compression ring in cylinder	Gauge $\Phi 100_{+0.008}^0$	0.40 ~ 0.60	3.00	
		Gauge $\Phi 105_{+0.008}^0$	0.40 ~ 0.60	3.00	
12	Gap of second compression ring in cylinder	Gauge $\Phi 100_{+0.000}^0$	0.30 ~ 0.50	3.00	
		Gauge $\Phi 105_{+0.000}^0$	0.30 ~ 0.50	3.00	
13	Gap of oil compression ring in cylinder	Gauge $\Phi 100_{+0.008}^0$	0.20 ~ 0.40	3.00	
		Gauge $\Phi 105_{+0.008}^0$	0.20 ~ 0.40	3.00	
14	Camshaft journal neck and bushing	Shaft $\Phi 54_{-0.003}^{+0.002}$	0.062 ~ 0.125	0.25	
		Holet $\Phi 54_{-0.062}^{+0.100}$			
15	Camshaft thrust plate and journal meck	Shaft $\Phi 6_{-0.05}^0$	axile clearance	0.40	
		Holet $\Phi 6_{+0.05}^0$	0.05 ~ 0.15		
16	Valve push rod and push rod hole	Shaft $\Phi 30_{-0.061}^{-0.040}$	0.040 ~ 0.082	0.20	
		Holet $\Phi 30_{+0.021}^0$			



No	Matched parts	Standard size	Matched clearance	Wear limit
17	Idler shaft and idler shaft bushing	Shaft $\Phi 30^{+0.025}_{-0.050}$	0.025 ~ 0.075	0.20
		Holet $\Phi 30_0^{+0.025}$		
18	Idler and idler shaft		axial clearance 0.038 ~ 0.095	
19	Contacting clearance of various timing ge		clearance of tooth flank 0.10 ~ 0.15	0.60
20	Air intake valve and valve guide	Shaft $\Phi 9.5^{+0.025}_{-0.045}$		0.20
		Holet $\Phi 9.5_0^{+0.019}$		
21	Exhaust valve and valve guide	Shaft $\Phi 9.5^{+0.038}_{-0.058}$		0.30
		Holet $\Phi 9.5_0^{+0.019}$		
22	Rocker arm shaft and bushing	Shaft $\Phi 25^{+0.020}_{-0.040}$		0.20
		Holet $\Phi 25_0^{+0.021}$		
23	Cylinder liner over the cylinder block surface		(delective fitted) 0.050 ~ 0.120	
24	Water pump impeller and pump body		back clearance 0.08 ~ 1.27	
25	Water pump impeller and packing block		Adjusting clearance	

## Chapter II Main Structure of Diesel Engine

### 1. Cylinder head assembly

R100 series diesel engines have the same kind of cylinder head with R105 series diesel engines.

Cylinder head is a single piece casting structure, with independent intake, and exhaust ports on both sides. The intake port is a helicoid type designing. In order to decrease the heat load of cylinder head, and consider of the supercharged condition, the cylinder head base wall thickness is different at the area of valve distance and injector seat hole, and cooled by inject cooling water. The valve guide and intake & exhaust valve seats are interference fit with cylinder head very tightly. Valve seat ring is made of heat resisting and wear - resisting Chrome - molybdenum casting.

Intake & exhaust valve and valve seat have been run - in when using, remember the number of cylinder when disassembly and assembly. When sealing condition between valve and valve seat is not good, lapping is necessary, and should be clean before assembly. After long time operating, the width of valve seat contacting area may be over 2.5mm, or valve seat damaged or non - round, reaming should be done, or change valve seat if necessary. When assembly, cylinder head should be heated at about 200°C, then the valve seat can be in - laid, after that ream and lap it at the contact area and make it at 1.3 ~ 1.5 mm in width, valve setting value is 0.6 ~ 1.0 mm down.

A copper - asbestos gasket is fitted between the cylinder head and the cylinder block. The cylinder head is tightened on the cylinder block by 18 (for four - cylinder diesel engine) or 26 (for six - cylinder diesel engine) strengthen bolts and quenched bolt gaskets. The cylinder head bolts should be tightened evenly by three times one by one in regulated order and torque. (Fig. 1)

Fig. 1 The sequence of tightening cylinder head bolts

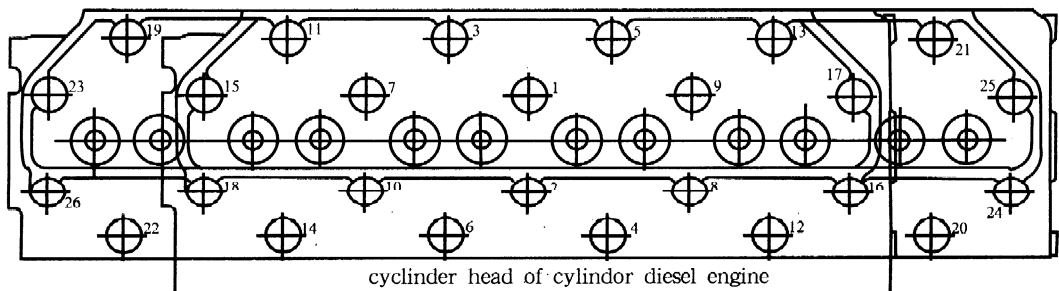

## 2. Cylinder block and related assembly

The cylinder block of R series diesel engine is short skirt construction without side opening. The main oil distributing passage is at the left side of cylinder block (view from flywheel end), the fuel injection pump, oil filter, fuel filter and oil cooler are at this side as well. The push – rod chamber are located at the right side of cylinder block, crankshaft case ventilator, generator, starting motor, air compressor and hydraulic pump as well.

A laser quenched wet cylinder liner is fitted in the upper part of cylinder block. In order to press it tight enough, its upper end is 0.05 ~0.12mm, higher than that of cylinder block.

The main bearing at the lower part of cylinder block is a full supporting type. The main bearing cover is positioned horizontally by shoulders at sides of cylinder block, and is machined together with cylinder block, thus can not be changed each other. For this reason, each main bearing cover has its sequential number and a triangle symbol, the arrow of triangle is to the front. Each upper main bearing half has oil holes on it. The bearings are all made of steel back aluminum alloy. The clearance between main bearing and crankshaft journal is not adjustable. Whenever the clearance is over limited value after bearing worn, it must be to change the bearings. When tight the main bearing bolts, each two bolts at one same bearing should be tightened gradually and alternately into specified torque. As there is anti – loose quenched gasket, the main bearing bolts have no locked gasket.

## 3. Camshaft assembly

The camshaft of R series diesel engine is full supporting, the cam is function cam, to adapt different working speed. Camshaft is driven by crankshaft timing gear through idling gear and camshaft timing gear. There are engage marks on the timing gear, the marks should be aligned when assembly. There assembled a camshaft thrust plate between camshaft timing gear and shaft collar, to control the axial clearance of camshaft.

The material of valve tappet stem is chill Ferro - nickel (iron) with the bottom surface of quench hardened and phosphorized. The axial line of tappet stem deviate the width central line of the cam 2mm, so that the tappet stem cam rotate surround its own axis to make the contact surface wore evenly. The theoretical valve timing diagram is as Fig. 2. In order to assure the normal running of diesel engine, he adjusting of intake and exhaust valve clearance should be within specified range.

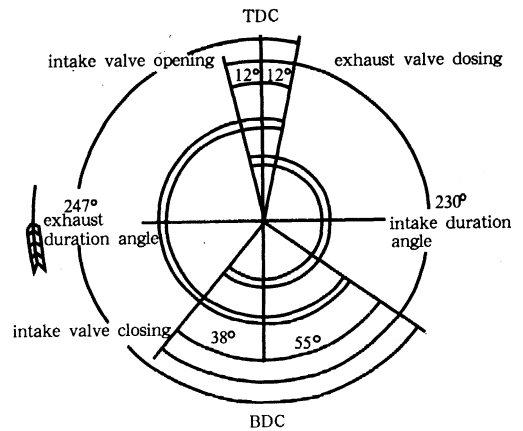

Fig. 2 Theoretical valve timing diagram

#### 4. Piston and connecting rod assembly

Except piston, piston ring and piston pin are different between R100 and R105 series diesel engines, other parts of connecting rod including connecting rod element, connecting rod bearing are all interchangeable.

Each piston of diesel engine has two compression rings and one scraper ring. The first compression ring is distorted barrel chrome - plate ring of modular cast iron, to improve the abrasive resistance under high temperature. The second ring is taper - face ring.

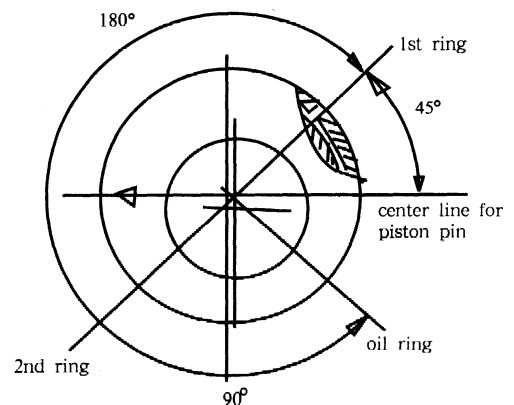

Fig. 3 The opening clearance of piston rings in cylinder liner

The side of the first and second piston rings with the word 'top' on it, should be faced at top side when assembled. The scraper ring is a component with inner spiral spring. As assembling scraper ring, the opening of the inner spiral spring maintain reed should be at the opposite side of the opening of scraper ring. When piston is assembled, the arrowhead on its top should be at the same side with the word 'front' on connecting rod, i. e. the arrowhead on top of the piston should be to the

front of engine. As assembling piston ring, first it should be put in cylinder liner, then be checked with clearance gauge to find out if the opening clearance is in the specified scope. If clearance is too small, repair with file. Piston rings should be staggered  $-120^{\circ}\text{C}$  with each other, and meanwhile avoid the direction of piston pin hole. See to Fig. 3. When assemble the piston into engine, the piston ring, piston pin, connecting rod liner and connecting rod bearing should be coated with enough grease. R series diesel engine has ' $\omega$ ' type combustion chamber at the top of piston, with the surface of spraying coating graphite of tin - coated. The piston of R series strengthen diesel engine is controllable heat expansion piston with the skirt inlaid by steel sheet. the first is direct to cooling nozzle.

The piston pin is full floating type, and can be rotate in piston pin hole as it getting to certain working temperature, to make wearing evenly. But it is cool, it is interference fit between piston pin and the piston pin hole. So when assemble and disassemble the piston pin, the piston should be preheated to  $80 - 90^{\circ}\text{C}$ . Assemble piston pin by force at cool temperature is prohibited, otherwise the pinhole may be ruined. Piston pin should stagger 1mm to non - pressure plane relative to piston center, to decrease piston knock.

Connecting rod body and connecting rod cap are positioned by single - tooth, and have marking numbers at same side, when assembled, the number must be registered. The small end bushing of connecting rod is wrapped bush by bimetal material, the oil holes on the bushing should be right aligned to the oil gathering hole at the top of connecting rod small end, to lubricate piston pin and bushing. Connecting rod bolts should be tightened evenly with specified torque strictly, connecting rod bolts are self - locked by friction force. The mass difference of connecting rod for one same diesel engine is less than 12g, and that of piston and connecting rod assembly for one same diesel engine is not bigger than 20g.

Connecting rod bearing of R series diesel engine is usually made of steel - backed aluminum alloy material. Connecting rod bearing of strengthen diesel engine is made of steel - backed copper - lead alloy. It is unadjustable for the gap between shaft bearing shell and shaft neck, when wearing capacity is over limited value, the bearing shell must be changed.

#### 5. Crankshaft and flywheel assembly

The crankshaft is made of QT800 - 3 high strength modular cast iron, and is full sup-

porting type. All the surface of shaft neck is quenched or nitrided, to improve the wearing resistance. For 6 – cylinder high – speed strengthen diesel engine, the crankshaft is made of No. 45 steel material, the main shaft neck and connecting rod shaft neck are treated by induction quench.

The front and rear end are sealed by skeleton structure rubber oil seal. There are two connecting methods of the crankshaft front end, one is multiple keys for full output, another one is flat key. When output power is needed at the front end, Multiple keys and casting pulley should be adopted. Otherwise, flat key and rotary pulley should be used instead. In order to decrease the torsion stress of crankshaft and the noisy of engine, rubber shrunk – in torque insulator element can be used if necessary.

Flywheel is positioned by cylindrical pin, and fastened on the rear end of crankshaft by seven high strength bolts. Flywheel bolts should be tightened gradually according to the sequence shown in Fig. 4. Flywheel bolts are self – locked by flywheel bolt gaskets. The gaskets are made of 15 # steel treated by cementation process.

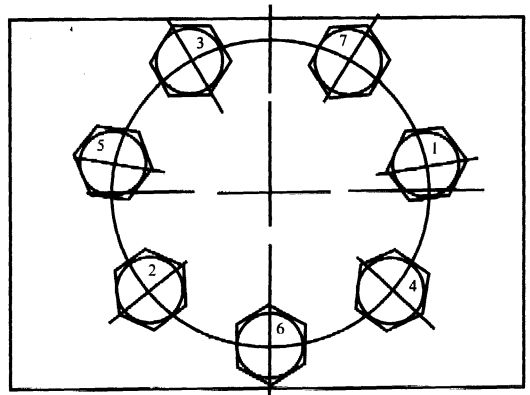

Fig. 4 The tighten sequence of flywheel bolts

The outside of flywheel is marked TDC point, and also the scale range of 0 ~ 30° of advanced used to adjust advanced angle of supplying fuel. Each scale means 1° crankshaft angle of turn. For some models of engines, the TDC point is marked at the flywheel end face of crankshaft pulley.

## 6. Transmission system

the diesel engine transmission system is including to normal V – belt transmission and the gear transmission inside gear case. Shown in Fig. 5.

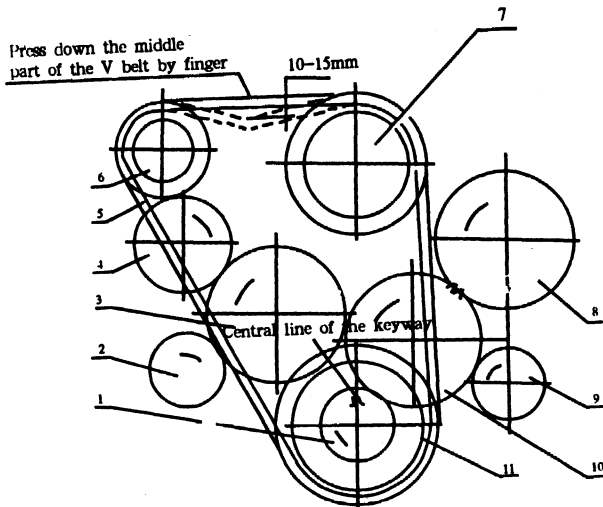

Fig. 5 Transmission system

1. Crankshaft timing gear ( $Z = 30$ )
2. Hydraulic pump driving gear ( $Z = 29$ )
3. Camshaft timing gear ( $Z = 60$ )
4. Air compressor of working pump driving gear ( $Z = 39$ )
5. Common V belt
6. Alternator belt wheel
7. Water pump belt wheel
8. Fuel pump timing gear ( $Z = 60$ )
9. Oil pump driving gear ( $Z = 30$ )
10. Idler gear ( $Z = 58$ )
11. Crankshaft belt wheel

Crankshaft pulley is consisted of two A - type V - belt to drive water pump pulley and alternator pulley. Different of V - belts are used because of the different position of water pump and alternator. V - belt is tensioned by alternator adjustment mechanism. When press the center of V - belt by finger, 10 ~ 15mm depth should be available.

Crankshaft timing gear drives idling gear, idling gear drives camshaft timing gear, fuel injection pump timing gear and oil pump gear. Camshaft timing gear may drive air compressor gear of work pump gear and hydraulic pump gear if necessary. Hydraulic pump gear may drive the front and the rear hydraulic pump through the transmission splined hobs of hydraulic pump or one of them.

## 7. Intake and exhaust system

### 7.1 Air filter

When the diesel engine is working, clean and fresh air is required to be supplied by the air filter, this can assure to reduce the wear of cylinder liner, piston, piston rings, valve and other parts.

For the air filter equipped with R series diesel engine, besides one or two types are equipped by OEM, the common two structure styles are as follows single stage paper filter element style and double stages paper filter element style

### 7.2 Silencer

In order to reduce the noise and improve the operator's working environment, R series diesel engine adopts exhaust silencer. The exhaust gas of the diesel engine expands through the holes of the silencer inner pipes and the noise is reduced. If the

silence is choked, the output of the diesel engine will erop. So the carbon deposit and iron rust inside the silencer should be cleaned periodically according to the working condition of the diesel engine.

The construction of silencers used for four cylinders and six cylinders diesel engine is just the same, only the capacity is different. according to the matched requirement, the connecting pipe can be lengthened or prepared by users.

According the matched requirement, the main installing mode of silencer for R series diesel engine is horizontal style and vertical style.

### 7.3 Turbocharger

R series diesel engine is made by adding a turbocharger between the intake and exhaust pipe of the natural aspirated type diesel engine. Through the turbine, the turbocharger transforms the exhaust energy of the diesel engine to the rotating mechanical energy of the rotor, then the blower is driven to rotate at a high speed and compress the fresh air coming from the air filter, then delivery it to the cylinder. Through supplying more air to the diesel engine, more fuel will be burned thoroughly and the output of the diesel engine will be increased accordingly.

The turbocharger is combined with constant pressurt single inlet turbine bousing or pulse double inlet turbine housing, turbine ass embly, blower pump impeller, blower housing and so on.

The turbocharger is a high speed – rotating machine, its rotating speed will influence the superchargine effect of the diesel engine directly. In order to assure the diesel engine working normally, the lubricating oit supplied to the turbocharger must be double stages filtered. When being used, the turbocharger must be technically maintained in time strictly according to the stipulation on the turbocharger – operating manual. The blower must be cleaned regularly according to the operating requirement. The turbocharger should be dismantled by skilled professional technical workers. A point should be paidattention to that when the lock nut on the end of the blower is being tightened, the reticule on the nut should be aligned with the reticules on the rotor shaft cscrew and blower impeller. This can protect the running balance of the rotor from being damaged and assure it working normally.

### 8. Fuel System

Fuel system is shown in Fig. 6



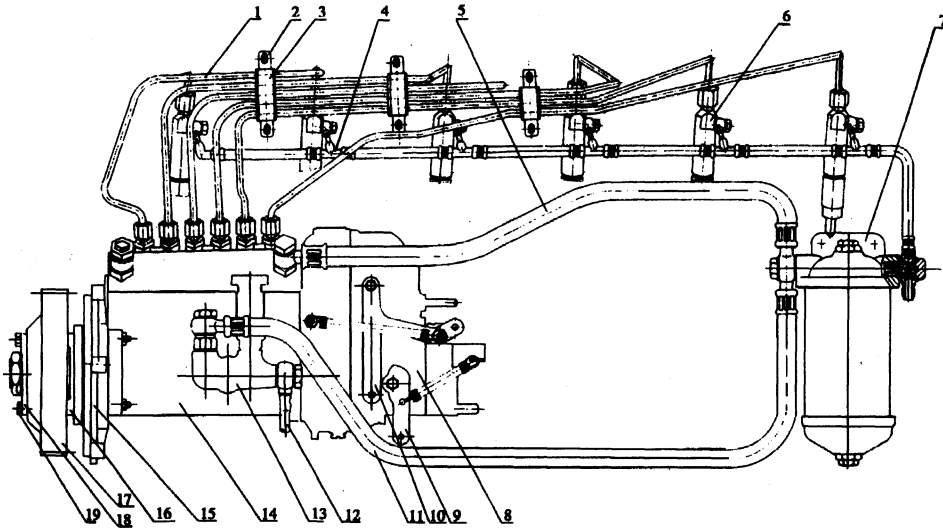

Fig. 6 Fuel system

1. High pressure fuel manifold 2. Pipe clamping plate 3. Rubber gasket 4. Injector fuel return pipe assembly 5. Injection pump fuel inlet pipe assembly 6. Injector 7. Fuel filter assembly 8. Governor 9. Stopping handle 10. Speed adjusted handle 11. Fuel filter inlet pipe assembly 12. Fuel delivery pump inlet pipe assembly 13. Fuel delivery pump 14. Injection pump 15. Injection pump fixed bolt 16. Advancer 17. Injection pump gear 18. Injection pump gear pressing plate 19. Bolt

When the diesel engine is working fuel flows through fuel tank, inlet pipe, fuel delivery pump into the fuel filter, after being filtered, it enters into the injection pump, then being compressed with plunger mate to high pressure, through fuel cock and high pressure fuel pipe, it enters into injector. When the pressure is high enough to open the needle valve mate of the injector, the fuel will be sprayed into combustion chamber in the form of atomization. After spraying, the pressure will gets lower, the needle valve returns to the seat under the force of spring, the injecting hole no sprays again.

The extra fuel that the fuel delivery pump supplies more than the injection pump used, also with the fuel that the injector needle valve mate leaks and the returning fuel of the fuel filter and the injection pump will flows back to the fuel tank.

#### 8. 1 Fuel delivery pump

The purpose of the fuel delivery pump is to keep the low - pressure fuel pipe full of pressed fuel. In order to remain the pressure stable, the piston of the fuel delivery

pump is pressure regulated automatically type. When the pressure of the low pressure fuel pipe higher more than the stipulated value, the higher pressure will press the backup spring through the piston and force the piston away from the push rod gradually, this can reduce the amount of the delivered fuel or stop delivering. Inversely, will add or continue delivering.

The hand press is used to make the fuel deliver pipe full of fuel and to wipe off air before the engine starts. When the engine is not at working situation, the handle nut should be tightened.

## 8.2 Fuel filter

In order to meet different requirements, there are three types of fuel filter: CS0708B1, CS0712B1, C0810S, the former two are single stage type, C0810S is double stages type.

The purpose of the fuel filter is to filter the tiny impurity out of fuel to reduce the wear of the precise mates inside the high pressure and injector.

After the fuel being filtered with element, dirt is kept on the element outer surface. Being made of fuel filter paper, the element should be maintained and replaced regularly. For the fuel filter with water deposited cup, the water in the cup should be drained off regularly.

## 8.3 Fuel injection pump

There is type A of high – pressure pumps; The body of the type A pump is an all – in – one – piece style, as shown in Fig. 7.

The quantity of fuel delivered for the fuel pump varies according to the load of the diesel engine. This is achieved by the rotating of plunger made by the shaft rotating movement of the adjusting rod gear. The injected fuel rate can be changed by adjusting the cam working section and the diameter of the plunger so as to meet the different requirement of the diesel engine characteristics. The front of the fuel pump is fixed on the gear housing by the fuel pump fixing flange. When installing, please match well with the gear so as to ensure the fuel delivery advance angle correct. The adjusting method of the fuel delivery advance angle is to discharge the fuel pump on the gear housing cover and check the cover timely; loosen the platen screw fixed on the fuel pump gear hub; turn the hex head bolt on the end of the fuel pump bearing; turning clockwise will add the fuel delivery advance angle while turning anticlockwise will reduce the fuel delivery advance angle. After adjusting properly, fasten the four platen screw and the six hex head bolt on the end of the fuel pump bearing to avoid them loosening.

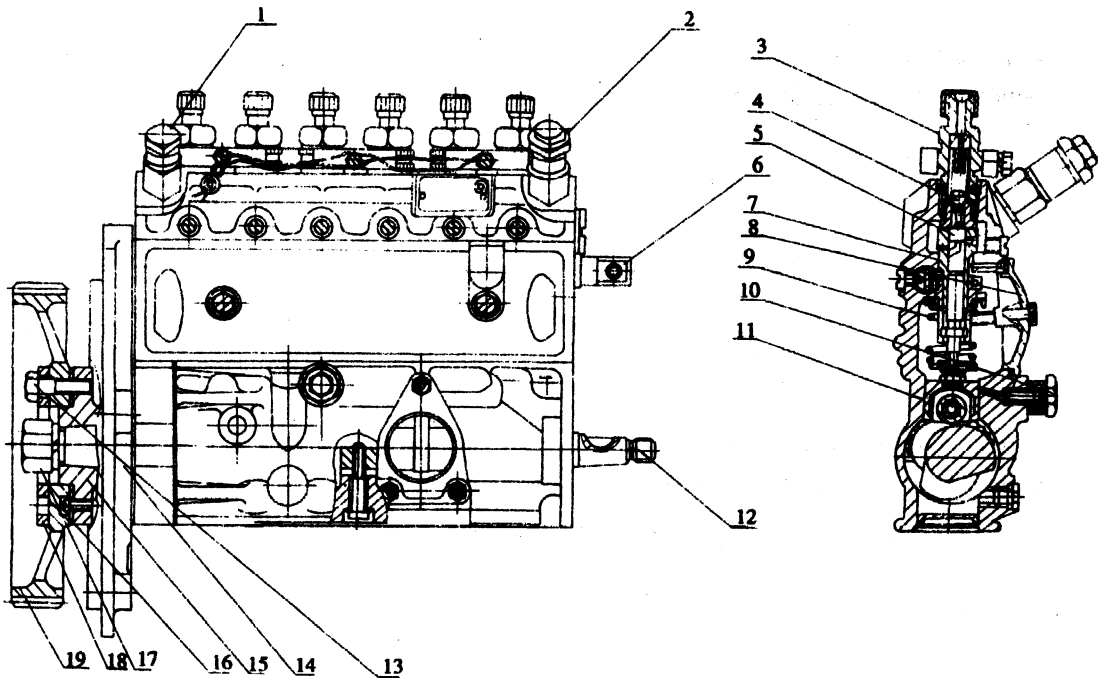

Fig. 7 Six cylinder A type fuel injection pump

1. Fuel inlet adaptor 2. Fuel return adaptor 3. Fuel outlet valve tightening seat 4. Fuel outlet valve 5. Plunger mate 6. Adjusting rod gear 7. Adjusting ring gear 8. Inspection window cover 9. Plunger spring 10. Oil groove screw 11. Pump assembly 12. Fuel pump camshaft 13. Bolt 14. Fuel pump fixing flange 15. Fuel pump gear hub 16. Fuel pump timing plate 17. Nut 18. Fuel pump gear platen 19. Fuel pump gear

The quantity of fuel delivered by the high pressure pump has been adjusted before letting released from factory. It's forbidden to open the high pressure pump inspection window cover to rotate the plunger so as to prevent the delivered fuel quantity and the fuel quantity in cylinders from being changed, if necessary, the adjustment should be operated on a high pressure pump test bench.

#### 8.4 Governor

There is a RSV mechanical full range type governor. Vehicle diesel engine is equipped with a RFD full full range - double poles type governor.

The function of the RSV full range type governor is to keep the speed of the diesel engine varying in the scope of fluctuating rate when the load doesn't change and varying in the scope of stable speed adjusted rate when the load changes so that it can work stably.

The high speed position limiting bolt and low speed position limiting bolt are used to adjust the highest idling speed and the lowest idling stable speed separately. The fuel quantity limiting screw is used to adjust the quantity of fuel delivered to the fuel

pump. We can change the working condition of the diesel engine by changing the position of speed adjusting handle. When you want to stop the diesel engine, just turn the stopping handle.

RFD type governor is specially used for the diesel engine matched with vehicle. You can use either the full range governor or the double poles governor. The double poles governor is useful only when the engine idle without load or exceeds the rated speed but not between the idling speed and the rated speed. This moment, the quantity of fuel delivered varies trough the changing of the position of the speed adjusting handle.

To make the quantity of fuel delivered match with the quantity of air intaked, we can install the inlet manifold pressure compensator on the governor of the turbocharged type diesel engine, thus avoid exhausting smoke.

### 8.5 Advancer

The Q285 ,Q286 type advancer is shown as Fig. 8

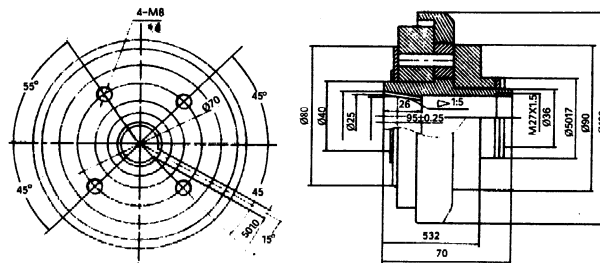

Fig. 8 The Q285 , Q286 type advancer

To improve the working procedure, the engines of which the rated speed is above 2600r/min should adopt Q285 , Q286 type advancer. When the speed is at 1100 – 2800r/min, the advancer can make the fuel advanced angle about 0 – 10° crank-shaft turning angle advanced.

The function of the advancer is to make the fuel advanced angle raise automatically, thus meet the requirement of the diesel engine.

### 8.6 injector

The injector is shown in Fig. 9.

The purpose of the injector is to spray the atomized fuel into the combustion chamber timely, and make the atomized fuel combined with air to make up a sophisticated

burning procedure.

R series diesel engine adopts J series and S series injector, all these two models are spring low installed and low inertia types injector. The needle valve mate of the injector is a long and holey style, in general, R100 adopts needle valve mate with 4 -  $\Phi 0.27$ mm spray holes R105 adopts needle valve mate with 4 -  $\Phi 0.30$ mm spray holes. The fuel should be atomized evenly after being sprayed, and the fuel stopping should be functioned at once, no fuel late drops or leakage. When the fuel atomized not well, the injector should be tested and adjusted on the injector test bench. the injector opening pressure is 20( +1.00) Mpa, if the pressure is not suitable, the thickness of the injector pressure Adjusted gasket should be adjusted, if the gasket is added more 0.1mm, the injecting pressure will be improved about 1Mpa.

The needle valve mate is matched mate, never exchanged when dismantled. The J series needle valve mate can't be exchanged with the S series needle valve mate, but their assemblies can be exchanged.

When the injector is installed on the cylinder head, there is a copper washer on the front, this can assure the tightness.

## 9. Lubricating System

The engine is lubricated by pressure oil combined with splash oil, the layout of lubricating system is shown in fig. 6

The oil is sucked into the oil pump through the strainer and the enters into the main oil passage after being cooled and filtered. The oil in the main oil passage of the cylinder block is delivered to the main bearings, connecting rod bearings, camshaft bushings, high pressure pump, air compressor, vacuum pump. The oil passing through the camshaft bushings, high pressure pump, air compressor, vacuum pump. The oil passing through the camshaft bushing flows through the oil passage in cylinder block and cylinder bead to lubricated the valve mechanism. Piston, piston pin, cylinder liner are all splash lubricated by the oil spilled from the bearings.

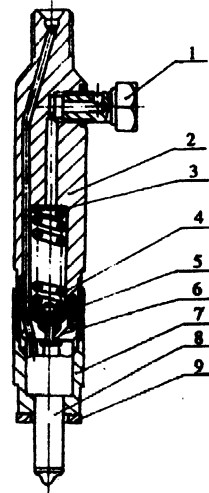

Fig. 9 Injector assembly

1. Fuel return adaptor screw
2. Injector block
3. Pressure adjusting gasket
4. Injector spring
5. support lever
6. Body subassembly
7. Injector tightening nut
8. Injector mate
9. Injector seal gasket

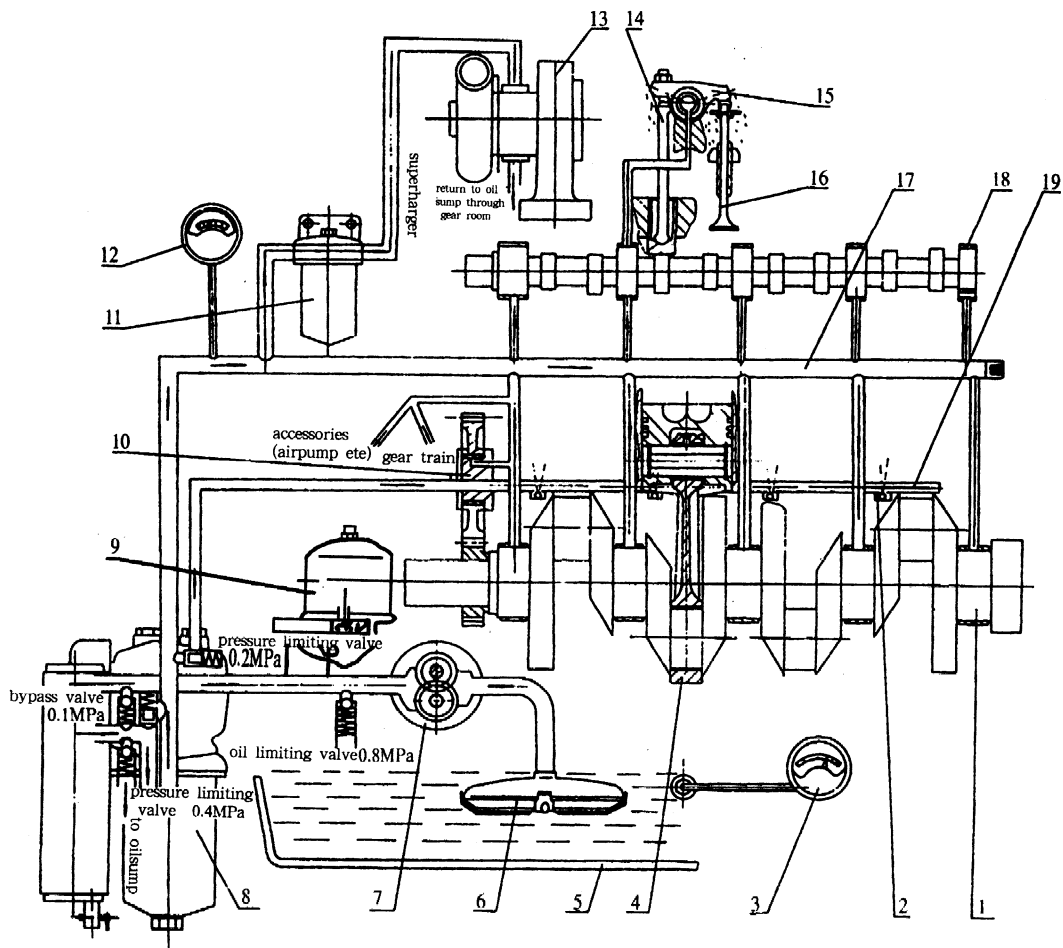

Fig. 10 Schematic diagram for the layout of lubricating system

1. crankshaft and bearing, 2. piston sooling injection nozzle, 3. oil temperature gauge, 4. piston and connecting rod assembly, 5. oil sump, 6. oil strainer, 7. oil pump, 8. oil filter and cooler, 9. centrifugal bypass type oil filter, 10. idling gear shaft and bushing, 11. oil fine filter, 12. oil pressure gauge, 13. turbocharger, 14. push rod, valve tappet, 15. rocker arm and arm shaft, 16. valve and valve guide, 17. main oil passage, 18. camshaft and bushing, 19. piston injection cooling oil passage.

For the supercharged engine, there is a special oil passage in the cylinder block for cooling piston, the oil injected into piston through oil passage and injection nozzle for cooling piston.

For lubricating turbocharger, portion of oil from oil main passage flows into turbocharger through another oil filter to lubricate and cool its bearing, then the oil flows

back to the oil sump through over flow oil pipe.

### 9.1 Oil pump

Four and six cylinders engine all use gear type oil pump. The structure of four cylinder engine is show in Fig. 11.

The oil pump should be installed in the tunnel on the upper part of the main bearing. The oil pump transmission gear is driven by the crankshaft gear trough the idling gear. The turning speed is the same as the crankshaft.

When the oil pump is being mounted, not too hard or deviated stress on it, the seal ring should be coated with lubricating oil so as not to be damaged.

### 9.2 Overload overflow valve

The overload overflow valve should be installed in the oil groove of the engine block, as seen in Fig. 12, to limit the low temperature and the high viscosity of the oil, protect the oil pressure gauge, thus assure the oil pump and the lubricating tube work normally. The overload overflow valve has been adjusted through the special test platform before use, so you neednt adjust again on general.

If the oil pressure is too low, you should regulate the regulating valve in the oil filter first, then you test and regulate this pressure regulating valve, it's opeing pressure is 0.8MPa.

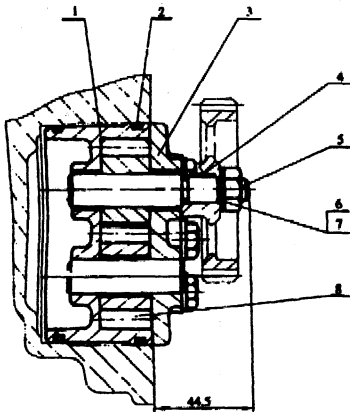

Fig. 11 Oil pump

1. Oil pump shell
2. "O" type seal ring
3. Oil pump cover
4. Half circle key
5. Driving shaft subassembly
6. Bolt
7. Gasket
8. Driven gears subassembly

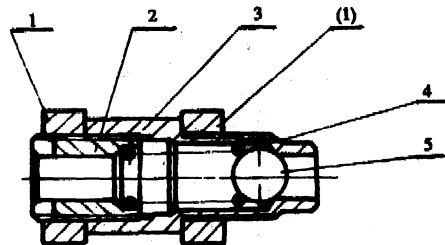

Fig. 12 Overload overflow valve

1. Nut
2. Fetaining plug
3. housing
- 4: Spring
5. Steel ball

### 9.3 Oil filter

The structure of JX0811a, J1012B and J0506 type oil filter is shown in Fig. 13 and Fig. 14.

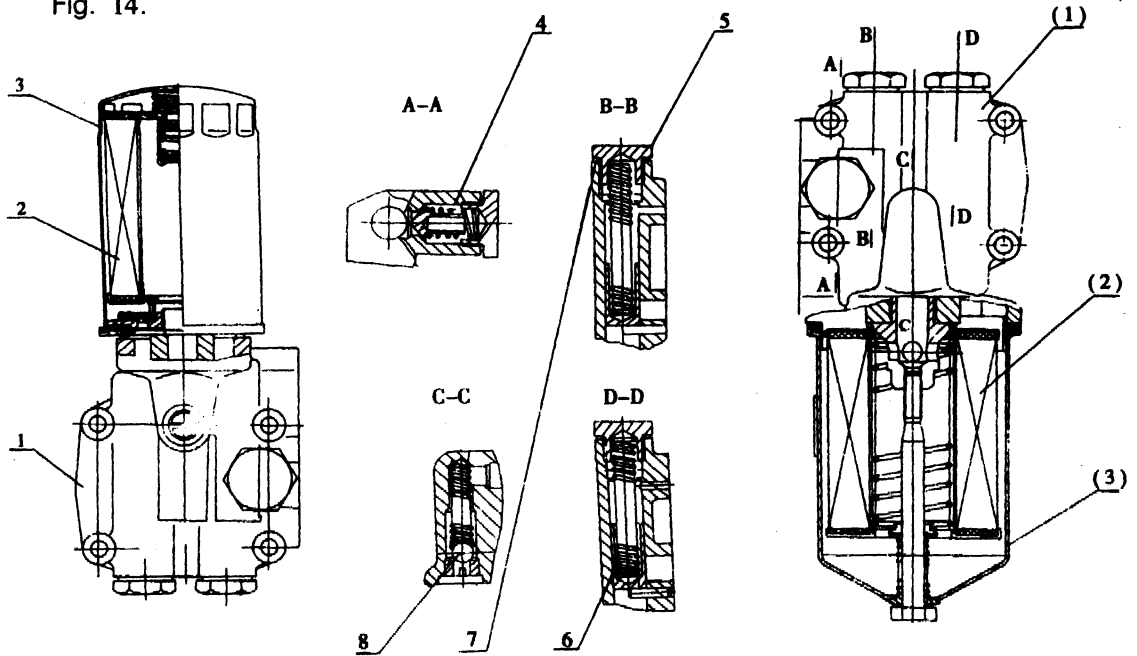

Fig. 13 Oil filter

1. Oil filter seat
2. Oil filter wick
3. housing
4. Bypass valve
5. Pressure limiting valve
6. Pressure adjusting gasket
7. Bypass valve

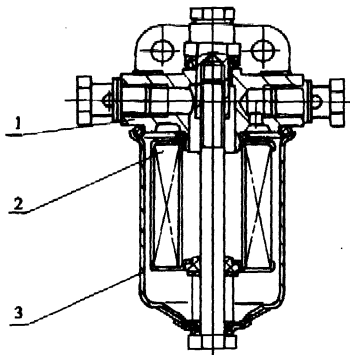

Fig. 14 Oil filter

1. Oil filter seat
2. Oil filter wick
3. housing

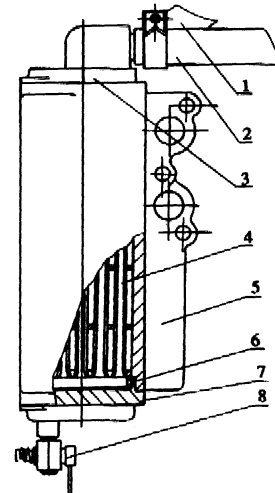

Fig. 15 Oil cooler

1. Water inlet tube
2. Water outlet tube
3. Oil cooler upper cover
4. Oil cooler wick
5. Oil cooler block
6. "O" seal ring
7. Oil cooler lower cover
8. Drain cock



JX0811a, J1012B type oil filter used to filter the engine lubricating oil, JO506 type oil filter used to filter the turbocharger lubricating oil.

There are pressure limiting valve and bypass valve. When the oil filter or the viscosity of the oil is too high, the bypass valve will open, and the oil will enter into the main passage without being filtered through oil cooler or filter to ensure the engine running safely. The bypass valve shouldn't be dismantled and adjusted without authorization. The paper element should be maintained and replaced periodically.

#### 9.4 Oil cooler

R series diesel engine adopts pipe & shell type oil cooler, which is shown as Fig. 15.

The oil cooler is usually installed at the side of the oil filter, oil from oil pump enters into oil cooler through the inlet hole of the shell. Through the hose, the cooling water enters into the cooling element from the special outlet hole at the left of the cylinder block. Because the water and oil has a different temperature and keep flowing, they exchange heat inside the cooler and the oil is cooled then. The cooling water from the cooler flows back into the cylinder head through the hose and the cooled oil flows into the main oil passage through the oil filter.

When using the engine, we should often observe whether there is engine oil mixed in the cooling water cycle system. If find water mixing with oil obviously, we should check immediately whether the seal ring of the oil cooler still work or whether the cooling element leak. If find any trouble, we must resolve it.

When changing the engine oil every time, we should change the oil filter wick at the same time.

#### 10. Cooling system

The engine adopts close type forced circulation water cooling system, is shown in Fig. 16

The cooling water in the radiator is forced by the water pump into the main water passage, which link up front and rear parts located at the left of the cylinder block. It flows into all cylinders evenly to cool the liners, most of water flows through all holes into cylinder head, the others enter into the rear of the cylinder head through oil cooler. If the oil cooler is not installed, the all cooling water will flows into cylinder head through cylinder block. About 35% of all water in the cylinder head flows transversely through the hole at the bridge of the nose, and it cools the heavy thermal duty angle

area. The other water flows vertically as; about 25% water flows to the exhaust manifold side, 30% water flows to the end of the cylinder head and the other 10% water maybe short circuit. This layout of cooling water determined by the layout of water holes and their sizes ensures the whole cylinder be cooled evenly and effectively. The used cooling water all flows back into the upper water case of the radiator through the thermostat from the front end of the cylinder head. When the water flows through the radiator, it is cooled with the air breathed in or the cylinder head. When the water flows through the radiator, it is cooled with the air breathed in or blow out by the fan, and the whole circulation is achieved. If the temperature of the water is too low, the thermostat will shut down, the water could't enter into the upper water case of the radiator and it flows back into the water pump through the small tube under the thermostat, the little circulation is achieved.

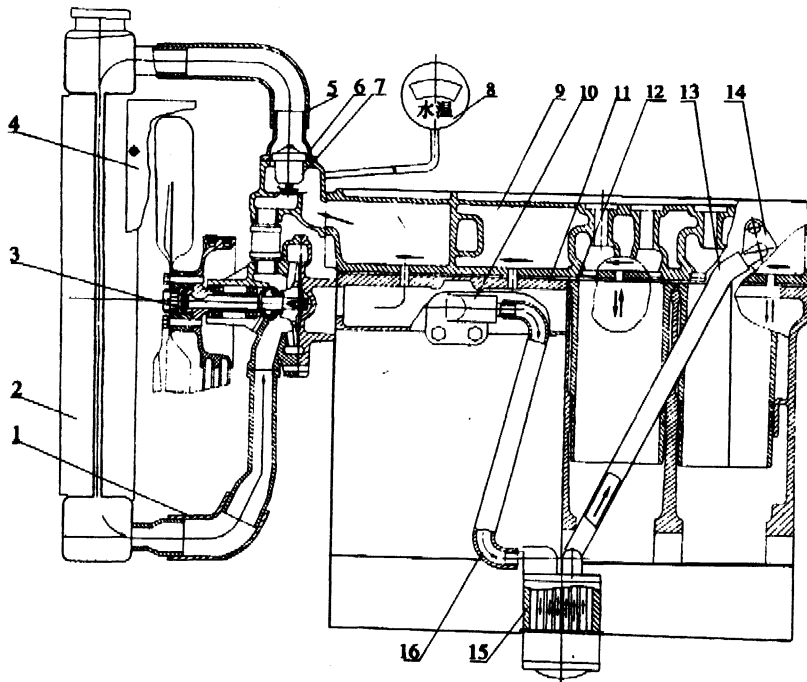

Fig. 16 Layout of coling system

1. radiator water outlet rubber hose 2. radiator 3. water pump fan assembly 4. cowling 5. radiator water inlet rubber hose 6. thermostat cover 7. thermostat 8. water temperature gauge 9. cylinder head 10. cooler water delivery connector assembly 11. cylinder block 12. cylinder liner 13. cooler water outlet tube 14. cooler water inlet connector assembly 15. oil cooler 16. cooler water inlet tube

The 4& 6—cylinder type R series diesel engine all adopts the same water pump. The temperature gauge of R series diesel engine can be chosen by users and can be

completed with temperature gauge connectors or temperature sensor connectors. For the cooling system of the marine diesel engine, the radiator and fan are replaced by sea water and fresh water heat exchanger. The water route includes two parts: One route is the sea water inlets by the sea water pump enter into the exchanger to cool the fresh water, then enter the exhaust manifold water jacket to cool the exhaust manifold. The other route is the fresh water in the inflation compensating water tank enter into the water pump through the exchanger, then enter into the engine block, oil cooler, cylinder head and the thermostat, then return to the inflation compensating water tank. This is a fresh water cycle of the marine diesel engine.

### 10.1 Water pump

The diesel engine adopts centrifugal water pump which is installed at the front of the engine block and driven by the crankshaft belt wheel through the V belt.

The water pump bearing is supported by the two dustproof bearing in the shell and rotates in the water pump. The vane wheel is installed at the end of the water pump bearing. There's china ring on the vane wheel neck, and between it and the pump shell there's water seal subassembly used to avoid water from leaking out of the pump block. To avoid the water leak into the rotating bearing, a water - relief hole is drilled under the seat hole of the pump bearing and a water throw ring is installed on the bearing to make the water leaked into the seal hole of the bearing spill over from the water - relief hole. If find the water - relief hole dripping water seriously, you should change the water seal.

Radiator connector can be added on the water pump shell and the cylinder head to supply heating for customers.

### 10.2 Fan

The diesel engine adopts vane axial - flow cooling fan which is installed at the front of the water pump belt wheel and rotates synchronously with the pump bearing.

According to the different application of the diesel engine and the surrounding temperature and wind quantity, the fan can be chosen as four or six leaf blades, wind absorbing or wind ejecting type.

### 10.3 Thermostat

The diesel engine adopts paraffin wax type thermostat.

The thermostat is installed in the thermostat shell at the position of water outlet mouth which is in front of or beside the cylinder head. It is used to control the quantity of cooling water flowed into the radiator, adjust the temperature of the cooling water and keep the engine working in a proper temperature most time.

The starting temperature of the thermostat main valve is  $77 \pm 2^{\circ}\text{C}$ , while the fully opening temperature is  $87 \pm 2^{\circ}\text{C}$ , and the raising travel of the valve for fully opening should not be less than 9mm.

If when the engine is started cooled, and the water temperature doesn't reach 75°C, there is water flowing out of the thermostat cover, or when the diesel engine is running and the water temperature exceeds 79°C, but there is no water flowing out of the thermostat cover, it indicates that trouble has been occurred with the thermostat, and it should be discharged and checked. The thermostat can't be discharged wantonly, otherwise, normal working of the engine would be influenced. To meet the requirements for different application, we have designed different thermostat covers.

#### 10.4 Sea water and fresh water heat exchanger

Marine diesel engine adopts sea water and fresh water heat exchanger. The structure is shown as Fig. 17.

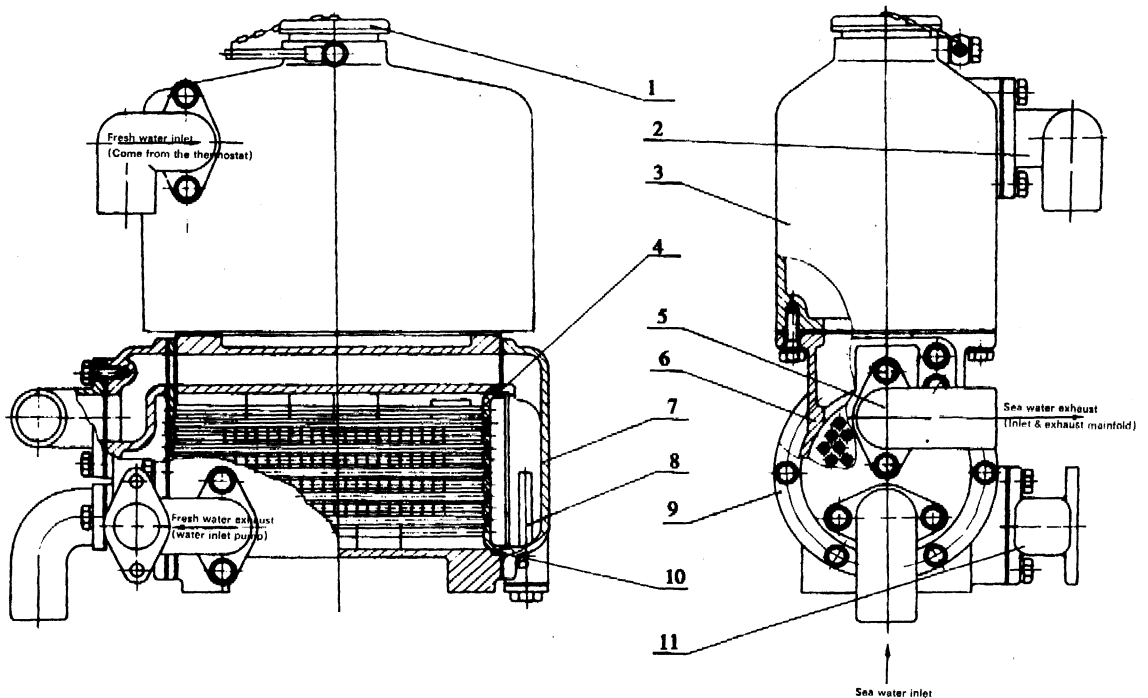

Fig. 17 Sea water and fresh water heat exchanger

1. Double type radiator cover subassembly
2. Water return flange
3. Inflation compensating water tank
4. Heat exchanger wick subassembly
5. Water pipe flange
6. Shell
7. Front end cover
8. Zinc stick subassembly
9. Rear end cover
10. Seal ring
11. Water pipe flange

Above the exchanger, there is an inflation compensating water tank. The sea water entered from the sea water pump cools the fresh water flowing by the internal groove of the exchanger wick and then cools the exhaust manifold; the fresh water in the compensating water tank enters into the water pump through the exchanger wick and does the fresh water cycle.

## 11. Electric system

The electric system of the R series diesel engine has two types: 12V and 24V, all are single wire system with negative pole grounded, can be chosen by users, shown in Fig. 18

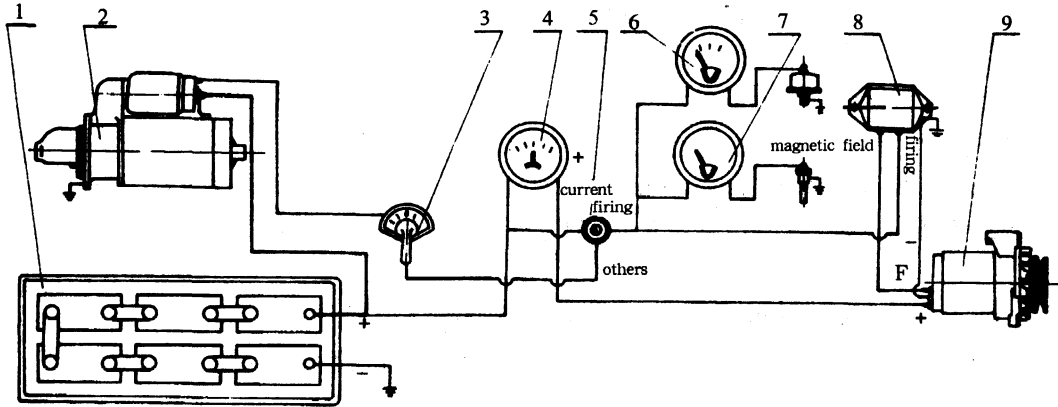

Fig. 18 lay out of electric system

1. battery 2. starting motor 3. starting switch 4. ammeter 5. key switch 6. pressure gauge 7. temperature gauge 8. voltage regulator 9. silicon rectified generator

The common and for tractor using diesel engines adopts 12V electric system; for engineering and truck using diesel engines adopts 24V electric system, can use more powerful 24V starting motor to improve starting capacity. The rated voltage of the motor and other electrical equipment must meet the voltage requirement of the electric system. In order to improve the diesel engine's coolly starting capacity, the coolly starting equipment installed at the air inlet pipe can be used by user's need.

### 11.1 Battery

The battery for start is a power device of the diesel engine, its performance influence the start of the diesel engine directly, suitable capacity battery should be chosen according to the starting motor's specific property. The battery should be installed near the starting motor so as to shorten the length of the cable between the battery and the starting motor to avoid the voltage drop too hard when the engine starting, the section area  $36\text{mm}^2$  low voltage connecting cable should be adopted.

When the starting current is highest, for 12V and 24V starting motor, the voltage drop should be less than 0.5V and 1V respectively.

The battery with the diesel engine hasn't been charged before delivery, it should be first charged as the battery's requirement before used. When the diesel engine is working, the amount of the charging current should often be noticed. When the needle of the ammeter is reaching to zero, it shows that the battery has been fully charged and the charging circuit can be switched off.

### 11.2 Silicon rectified dynamo

JF series silicon rectified dynamo is adopted in the diesel engine, there are many types of JF1312YE, JF2312YE, JF2512YE, JFZ1512YE, BJFW23B, and etc.

The diesel engine for tractor adopts JF1312YE type of 12v, the other engines usually adopt dynamo of 24V; the engine with vacuum pump adopts BJFW24B type, six cylinders engine for truck adopts JF2512YE type.

### 11.3 Voltage regulator

The use of this voltage regulator is to keep the voltage at the range of 13.5 – 14.5V or 27 – 29V respectively when the speed of the 14V or 28V generator changed. These two types of generators adopt FT111, FT211 AND FT226 voltage regulators respectively, the FT226 type regulator can be connected to a charging indicator.

When the FT111 type and FT211 type regulators are used, the key switch should be turned off as soon as the engine stops in case the battery discharge to the magnetic coil and make the battery insufficient, this will influence the next starting.

The regulator is a precise instrument and not be dismantled and regulated at will, if it is necessary to be adjusted, it should be done at special equipment.

### 11.4 Starting motor

The starting motor is full closed direct current series excitation motor, the engine of 12V system adopts QD1518E, QD154, Q154C types, and the engine of 24V system adopts QS2637E type starting motor. In order to improve the starting capacity, QD154C type motor adopts 9 teeth, and the QD154 adopts 11 teeth.

The working current of the starting motor is very large, it can only work within a short time, every starting time can't exceed 10s. If it's necessary to continuously start, the time interval shouldn't be less than 2 minutes in case the starting motor and the battery be damaged.

### 11.5 Key switch

The key switch has three working positions, at the center position, the whole circuit will be turned off, turning the key clockwise, the preheating - starting switch, Voltage regulator and other electric equipment will all be switched on and the diesel engine will start. After the engine starts, the switch should be turned counterclockwise to the end to turn off the preheating - starting switch and in case of any trouble.

### 11.6 preheating - starting switch

If the preheater be used, a preheating - starting switch should be adopted. The preheating - starting switch has four working positions. At the "Preheat" position, only the preheater or electric plunger be turned on. At the "preheat - start" position, both the preheater and the starting motor will be turned on. At the "start" position, only starting motor will be turned on. To loose the switch, it will automatically moves back to the "O" position and the whole circuit will be cut off.

## 12. Air compressor assembly

To meet the requirement for the break and aeration for tire of tractors, some types of vehicles and engineering machines, the relevant diesel engine derived products have installed LC126 type air compressor.

The structure of LC126 type air compressor is shown as Fig. 19.

Its structure is single cylinder piston type with a bore of 65mm and stroke of 38mm. The displacement of piston is 0.126L working displacement  $\geq 100\text{L}/\text{min}$ , exhausting pressure  $\geq 0.6\text{Mpa}$ , full load consumption power  $\leq 1.4\text{KW}$ .

The air compressor is driven by gear. When the air compressor is running, the piston is going down, the air opens the inlet valve and enters the cylinder through the air filter. When the piston is going up, the air will be compressed and push open the outlet valve and enter the air storage tube. According to the different load discharge method, there are two kinds of air compressor for customers choice.

#### 1. Inlet load discharge air compressor

There's a pressure releasing valve installed on the cylinder of the inlet load discharge

air compressor. The pressure releasing valve is connected with the pressure adjustor through pipe. When the pressure in the air storage tube reach a rated volume of the air adjustor, the compressed air in the air storage tube enter into the pressure releasing valve through the pressure adjustor, push up the valve rod and open the inlet valve, making the cylinder interlinked with the air, the air compressor idling, thus achieve load discharge.

## 2. Outlet load discharge air compressor

The outlet load discharge air compressor has no pressure releasing valve and pressure adjustor shown in Fig. 19. The original position of pressure releasing valve is blocked up by screw plug. A compound multi - functional load discharge valve is contacted between the air compressor and the air storage tube. The compressed air enter into the load discharge valve, first pass the oil and water division then open the exhaust one - way valve and enter the air storage type. When the pressure in the air storage tube reaches the rated volume, the exhaust one - way valve of the load discharge valve will close automatically to keep the rated volume of the air storage tube. Meanwhile, the load discharge valve opens automatically. The compressed air is exhausted into the air with the oil and water.

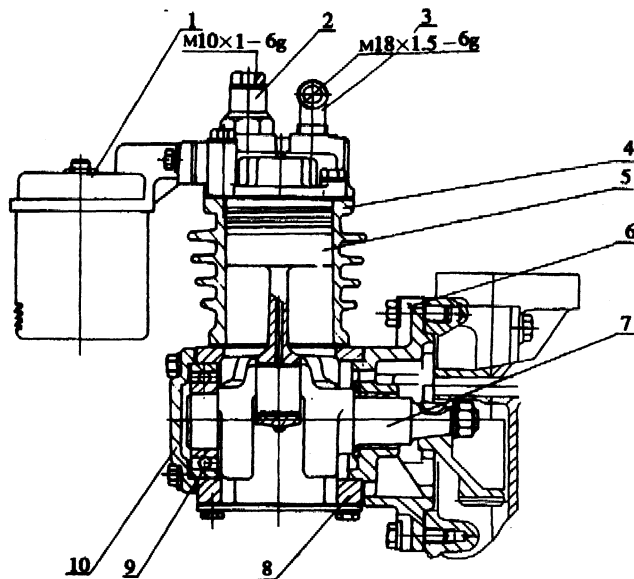

Fig. 19 LC126 air compressor assembly

1. Air cleanser 2. Cylinder head 3. Inlet load discharge valve 4. Cylinder block 5. Piston and connecting rod 6. Connecting flange 7. Crankshaft 8. Crankshaft tank 9. Bearing 10. End cover



## 13 Clutch assembly

### 13.1 The characteristic of the clutch's construction

The diesel engine adopts open, piece and dry type clutch, a disc type spring is adopted as elasticity compensation, shown in Fig. 20

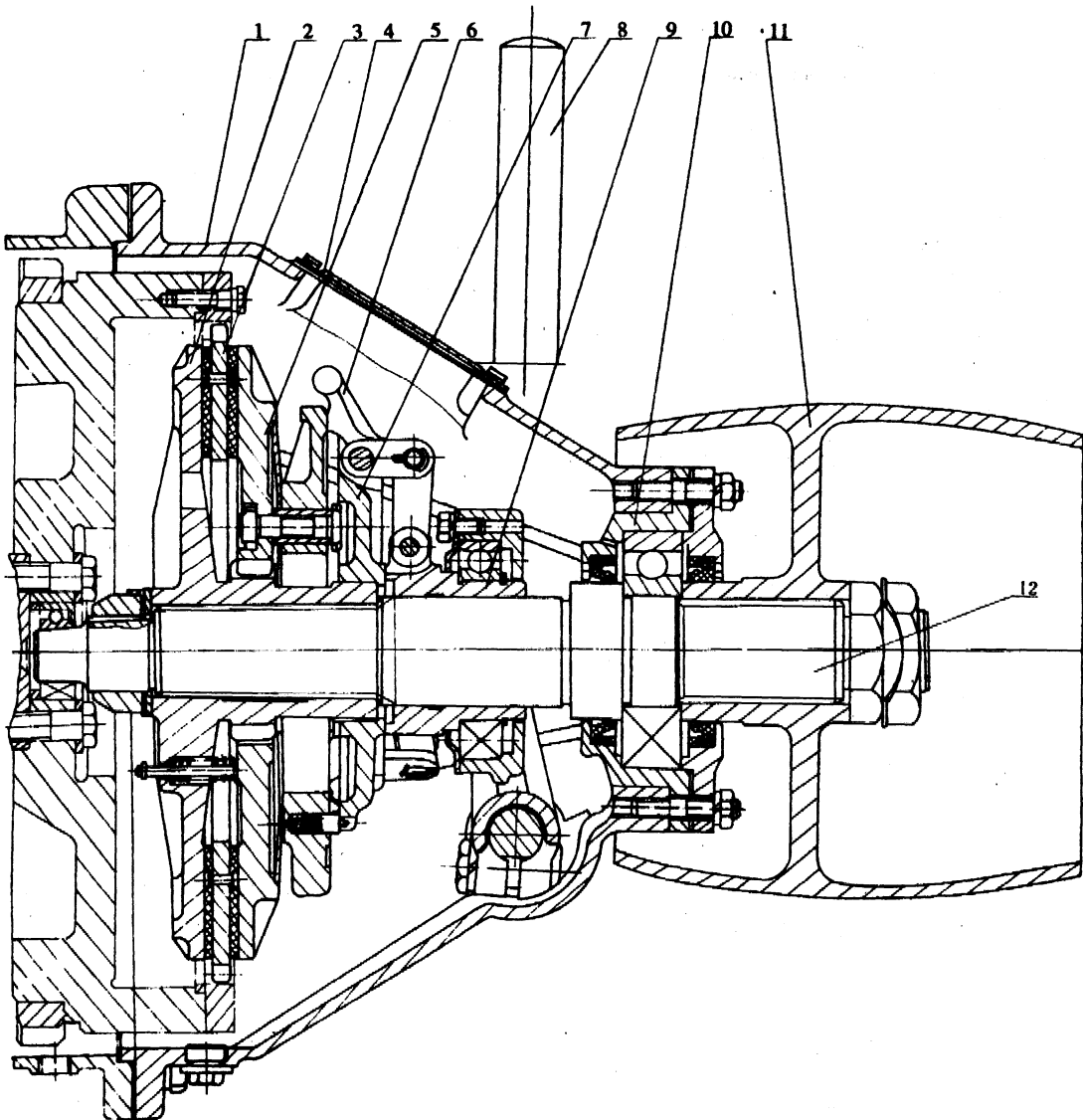

Fig. 20 clutch assembly

1. clutch housing 2. fixed pressure disc 3. friction slice 4. screw cover 5. moving pressure disc 6. pressure lever 7. adjusting disc 8. control lever 9. separating bearing assembly 10. rear bearing assembly 11. belt pulley 12. clutch shaft

The friction disc is the main transmission part of the clutch.

When the clutch is engaged, the friction disc is pressed between the fixed pressure disc and the front moving pressure disc. The power of the diesel engine is transmitted from the inner teeth ring to the moving pressure disc assembly and then to the splined shaft of the clutch, it is outputted from the belt pulley. A flat belt pulley, v-belt pulley or a coupler can be installed at the output end.

When the clutch is disengaged, the friction disc is combined with the inner teeth ring and rotates with the flywheel, other moving parts of the clutch are motionless and the workless state of the clutch is improved.

According to the inner teeth engaged with the outer teeth, the friction disc assembly can rotate with the flywheel and can slide axially. The fixed pressure disc is connected with the shaft of clutch by the rectangle spline, the front moving pressure disc is also engaged with the fixed pressure disc by the inner teeth and the outer teeth. Through the rear moving pressure disc moves axially with the pressure lever, the engagement and disengagement of the clutch is achieved.

The engagement of the clutch is kept with the self-lock of the pressure lever system, so the engagement of the clutch is very reliable.

### 13.2 Assemblage, dismantling and adjusting of the clutch

#### 13.2.1 Assemblage and dismantling of the clutch

The front end of the clutch output shaft is supported on the flywheel bearing, the rear end is supported on the bearing of the rear bearing seat inside the clutch housing. The clutch is connected with the diesel engine through the clutch housing combined with the diesel engine flywheel housing by the rabbet.

When you want to connect the clutch with the diesel engine, you can move the friction discs to the rabbet of the clutch housing all around evenly so that the friction discs are in the middle symmetrical state. After you move the lever to engage the clutch, you can connect and fasten it with the diesel engine.

When you want to dismantle the clutch from the diesel engine, you should engage

the clutch first and then dismantle the connecting bolt connected with the diesel engine so as for the next assemblage convenient.

### 13.2.2 Adjustment of the clutch

After the clutch be used for some time, if it's performance turns worse because of the wear of the friction discs, users can adjust it as follows:

(1) Put the clutch to the disengagement state, open the upper window, rotate the clutch shaft, peep at the lock pin of the adjusting plate, press the lock pin, rotate the adjusting plate clock wise, the adjusting plate will be pressed about 0.1mm per 12° gap. After the adjustment is finished, insert the lock pin into the corresponding gap.

(2) Push the clutch to the engagement state, use a special rule to test whether the distance between the rear moving pressure disc and the top end of the sleeve fixed bolt is 1 - 2mm.

### 13.3 Matters need attention

1) When the clutch is engaged and to out, put power, the time of engagement should be very short or it will burn the friction discs.

2) The asbestos friction discs must be protected from being dirtied by oil dirt.

3) There is a dirt - drained plug at the bottom of the clutch housing, the oil dirt and deposited water should be often drained off.

The window should be often opened when working, the safe pin of the opratin sysy-  
en should be tested to keep it in good condition.

5) Lubricating grease should be perodically filled into the oil cup as stipulated.

## **CHAPTER III OPERATION OF THE DIESEL ENGINE**

### **1. Transportation, installation, storage and preservation**

When the diesel engine is transported, the front and rear lifting bracket should be used to lift the engine and close attention should be paid to protect the appearance, accessories and oil pipes of the diesel engine from being damaged.

If the diesel engine will be transported for a long distance, the air filter and silencer should be dismantled, use plugs and plastics to seal the air intake and exhaust hole, water pump inlet and outlet hole, fuel inlet and outlet hole. If necessary, use plastic cover and wooden case to pack the diesel engine.

If the diesel engine is used for stationary application, the foundation must be firm, the mounting surface must be kept horizontal, the driving equipment should conform to the requirement of stipulation, the working place should be spacious, well ventilated, clean and rain - proof.

If the diesel engine is going to be laid up for a long time, it should be preserved and stored as the below methods;

- 1) Drain off fuel, oil and cooling water.
- 2) Remove the injector assembly away from the engine, fill to each cylinder with 200kg dehydrated clean oil (it means; keep the oil heated at 100 – 200°C until no bubble remains, rotate the crankshaft to let the lubricating oil coat evenly on the surfaces of the valves, cylinder liners and pistons, etc. ; then clean the appearance of the nozzle assembly, smear lubricating oil on it and then re - install it to the engine.
- 3) wrap up the air filter with plastic film, dismantle the silencer and stop up the exhaust hole with wooden plug.
- 4) wipe off the oil dirt, dust and rust from the outer surface of the engine, smear the unpainted parts surface with thin layer of anti - rusting grease (such as calcium type lubricating grease) , then cover it with paper.
- 5) Wrap the diesel engine in plastic film

6) the preserved engine should be stored in well ventilated, dry and clean room, it is strictly forbidden to be putted together with corrosive substances. The effective time of this method is 3 months, when the time exceeds the period, please repeat this procedure.

## 2. Fuel, lubricating oil and cooling water

### 2.1 Fuel oil

The diesel engine should adopt different brand of light diesel oil according to the atmospheric temperature (GB252 - 81)

Atmospheric temperature(°C):	>0	0 ~ -10	-10 ~ -20	-20 ~ 35
Brand of diesel oil:	0	-10	-20	-35

The fuel oil must be kept very clean, before filling it into the fuel tank, you should clear the fuel oil for over 3 days so as to make the dust and water inside the oil precipitated to the bottom, then pick up the top clean fuel oil. The fuel oil must be strictly filtered when filled to the fuel tank.

### 2.2 Lubricating oil

The diesel engine should adopt different brand L - ECC diesel lubricating oil according to different area and atmospheric temperature.

AREA	Winter In Cold Area	All Year In Common Area	Summer In The South
TEMPERATURE(°C)	-5 ~ -15	0 ~ 30	>30
OIL BRAND	20/20W	30	40

The turbocharged diesel engine should adopt L - ECD type diesel lubricating oil (GB11122 - 89)

AREA	Winter In Cold Area	All Year In Common Area	Summer In The South
TEMPERATURE(°C)	-5 ~ -15	0 ~ 30	>30
OIL BRAND	20/20W	30	40

The lubricating oil must be filtered before it is filled into diesel engine, other brand lubricating oil is forbidden to be used for engine so as to protect the parts such as bearing and piston ring from being damaged.

## 2.3 Cooling Water

The diesel engine should adopt clear soft water such as tap water, rain water and river water, etc. If hard water is adopted such as well water and spring water which contains much more minerals, the hard water should be softened, otherwise there will be scale on the water passage of the engine and block the water, weaken the cooling effect and result in the engine too hot.

One of the below methods can be used to soften water:

(1) boiled, precipitated and filtered before used.

(2) Fill 20g  $\text{Na}_3\text{PO}_3$  on each 10kg water, precipitated and piston ring from being damaged.

When the temperature is below  $0^\circ\text{C}$ , antifreeze mixture can be used for cooling medium. The antifreeze mixture can be mixed with water and alcohol according to the below ratio.

Volume ratio of antifreeze mixture( %)		Ice point of antifreeze mixture $^\circ\text{C}$	
water	alcohol	denatured alcohol	water alcohol
90	10	-3	-5
80	20	-7	-12
70	30	-12	-19
60	40	-19	-29
50	50	-28	-50

When compound and fill the antifreeze mixture, pay attention to:

(1) The antifreeze mixture is poisonous, never drink it.

(2) When the engine is working, the temperature of the antifreeze mixture doesn't exceed  $90^\circ\text{C}$  so as to avoid the alcohol volatilize.

(3) test the volume of the antifreeze mixture each 25 - 30hrs, compensate it if not enough.

(4) the volume of antifreeze mixture should be 6% less than the water, because the antifreeze mixture preventive liquid will expand at high temperature.

## 2.4 Auxiliary material

The types of glue R diesel engine adopt is as the following table:

The types of glue R diesel engine adopt and the applying position

No.	Name	Application and applying position
1	KB599	Apply on the bright metal surface for plain seal, for example, the connection face of the cylinder block and the oil seal.
2	KB15100 Tianshan 1515	Apply on the surface of the external cylinder and holes for fastness, for example, water plug and core plug of the cylinder block.
3	Tianshan 16747	For the seal of wick and hole. Applicable for seal of water cavity and oil groove, for example, all the core plug of the cylinder head.
4	Tianshan 1262	For the fastness of important screw thread, for example, camshaft screw etc.

- (1) When the temperature is below 5°C, the cooling water should be drained after stopping the engine.
- (2) When the temperature is below 0, we should check the consistency of anti-freeze for those adopt it.

### 3. Preparation for starting

- 3.1 The diesel engine should be thoroughly checked before starting. Closed attention should be paid to see whether foundation bolts and the connection with the driven equipment is rigid and reliable, and whether the transmission parts and control systems are sensitive and so on. The engine won't be started unless everything is all right.
- 3.2 Check and replenish the oil sump to keep the oil surface between the top and bottom carved line, fill up cooling water and fuel oil, open the switch of the fuel tank, check the fuel system for leakage and eliminate it if there is any.
- 3.3 It is recommend to vent the air out of fuel system step by step as follows:  
 At first loosen the venting screw on the filter, pump the fuel with priming hand pump, vent out the air from the fuel passage between the fuel tank and the filter, then loosen the venting screw on the injection pump until the fuel flows out without bubbles.
- 3.4 Check the battery be sufficien or not, connect the battery to the circuit and see whether it is electrified.

#### 4. starting

The diesel engine shouldn't be started until the preparation is completed and meets the requirement. When starting, the clutch should be apart, operate as following steps:

- 4.1 Set the control handle of the fuel valve to the position where the fuel will be delivered rather more.
- 4.2 Turn the circuit switch clockwise and close the circuit.
- 4.3 Turn the starting switch to the "starting position", after the crankshaft is speeded up by the starting motor, the engine is started then.
- 4.4 For the protection of the starting motor and battery, the starting time shouldn't exceed 10s. If need to start continuously, the interval time should be more than 2min. If can't start for continuous 3 times, then don't start until the trouble is found out and eliminated.
- 4.5 As soon as the engine starts, turn the starting switch back to the previous position. Set the control handle of the fuel valve to the idel speed position, turn the circuit key switch counterclockwise to the charging position.
- 4.6 Check the oil pressure after the engine starts, the oil pressure in ilde speed never be lower than 0.1mpa. After the engine starts for 5min, stop it and wait for 15 min, check the surface of the oil when the oil flows back to the oil sump, if necessary, add oil to the required level.

#### 5. running

- 5.1 After being started, the engine shouldn't operater at full load immediately. It should be warmed up at low speed without load, only after the temperature of the cooling water reaches to 60°C, it can be speeded up to the highest speed and operates at full load.
- 5.2 When operating, the engine's speed and load should be increased and decreased gradually. In general, shouldn't increase or decrease rapidly.
- 5.3 When the engine is working, should often pay attention to oil pressure, oil tmeperature, cooling water temperature, charging current, should also observe the color of the exhaust smoke, listen attentively to the voice inside. If any trouble such as overheating, black smoking, knock and others, should stop the engine to check and remedy immediately. It is forbidden to let the engine operate with



trouble so as to prevent the engine parts from being damaged.

- 5.4 When the engine working, often pay attention to the oil passage, water passage and union joint, if any leakage, should remedy it at once so as to avoid waste and pollution to the environment.
- 5.5 For new or just overhauled engine, it is permitted to run at full load only after it has worked for over 60h.
- 5.6 It is forbidden to let the engine running at idle speed for a long time.
- 5.7 The injection pump has been adjusted rightly before leaving factory, it is forbidden for users to change it at will. If necessary, it should be adjusted at the injection pump equipment.

## 6. Stopping

- 6.1 Before stopping the engine, unload first, decrease the engine to the idling speed gradually, when the water temperature falls down below 70°C, turn the stopping lever to stop. After the engine stops, take out the switch key and close the fuel tank valve.
- 6.2 It is forbidden to stop the engine suddenly at high water temperature.
- 6.3 It is not permitted to stop the engine by shutting off the valve of the fuel tank so as to prevent the air from entering into the oil passage.
- 6.4 When it is below 5°C, if the antifreeze mixture is not used, should drain off the cooling water so as to avoid the cylinder block and water pump being frost crack.
- 6.5 The found trouble should be remedied after every stopping, and should often check the engine.

## 7. The wearing in of the diesel engine

New and repaired diesel engine (including those have taken third grade technique maintenance and have changed piston, piston ring, cylinder liner, main bearing and connecting rod bearing) must have a long period of wearing from low load to high load gradually. We'd better make the various operations match well to avoid abnormal damage. Experience proved that the life of the diesel engine, its liability and economy are largely determined by the wearing in on the initial stage, so the customers should follow the wearing in instruction strictly.

The time of wearing in should not less than 60 hours. The load and time of wearing in is as follows:

Load	Operation time	
Idling speed	10 minutes	Check the pressure of lubricating oil and whether there is abnormal noise etc.
25%	2 h	
50%	15 h	
75%	30 h	
100%	15 h	

During the period of wearing in, the throttle should be fully opened. The load numeral value can be gained according to the load estimation of the matched belt, however, we must obey the principle of increasing load gradually from low load.

Due to the different fitting machines, such as tractors, vehicles, engineering machines, generating sets and harvesters etc., the wearing in should meet the different requirements for the usage. The diesel engine used for agricultural machines, for example, the diesel engine used for water pump, thresher and grinder etc., which have power take out equipment have already wearied in preliminarily, so customers can reduce the wearing in time properly.

## 8. Safe and technical operating instruction

- 8.1 It's forbidden to let the person who don't know the operating technique to operate the engine.
- 8.2 The engine can be started only after all the starting preparation has been completed.
- 8.3 Pay close attention to prevent fire, it's forbidden to let the naked flame near the working engine. If the engine is working beside inflammable substance, a fire extinguisher system should be installed on the exhaust manifold.
- 8.4 When the engine is working, never to dismantle or adjust, the operator don't leave the working site.
- 8.5 It's forbidden to let the engine working under no oil pressure, low oil pressure or which abnormal noise inside. If you meet with these cases, the engine should be stopped urgently.
- 8.6 If the engine happens to be overspeed, you should turn the stopping handle to stop it to have a test. If the stopping handle malfunctions, you can stop the en-

gine with the method of plugging up the air inlet hole.

## **CHAPTER IV Technique maintenance of the diesel engine**

Periodic technique maintenance is an important content of using engine normally, in order to remain the engine in good technique state and to prolong it's service life, the technique maintenance system must be seriously performed as standard.

The maintenance of the engine is classified as follows:

- 1) Working day maintenance (per 8 – 10h)
- 2) First grade technique maintenance (accumulative working hours: 50h; or for the cargo vehicle, traveling distance over 2500km)
- 3) Second grade technique maintenance (accumulative working hours: 250h; or for the cargo vehicle, traveling distance over 12500km)
- 4) Third grade technique maintenance (accumulative working hours: 1000h; or for the cargo vehicle, traveling distance over 50000km)
- 5) Technique maintenance on winter use.

### **1. Working day maintenance**

- 1.1 Check the oil surface in the oil sump, oil bath type air filter and the power output gear box, if the oil surface is higher, find out the trouble and eliminate it; if the oil is insufficient, the refill it to the required amount.
- 1.2 Check the cooling water surface in the water tank, if insufficient, fill it up. If the air temperature will be under  $+5^{\circ}\text{C}$ , then drain off the cooling water after stopping.
- 1.3 Check and fasten the shown bolt and nut, eliminate the leak of oil, water and air.
- 1.4 During working at the dusty place, use the compressed air to clean the air filter element.
- 1.5 Clean the mud, dust and oil dirt on the appearance of the engine.
- 1.6 When the engine is working, listen to the voice, observe the smoke color and eliminate the trouble and abnormal appearance.

### **2. First grade technique maintenance**

- 2.1 Perform the items on the "working day maintenance"
- 2.2 Clean the oil filter element with clear fuel. Clean the centrifugal oil filter once on two – maintenance period.
- 2.3 Clean the dust on the air filter element and inside the dust deposit set. Replace the oil inside the oilbath type air filter.
- 2.4 Check and adjust the tension of the fan belt.
- 2.5 Fill the lubricating grease into the weater pump bearing.
- 2.6 Check all parts of the engine, to do the necessary adjustment if need.
- 2.7 when the maintenance is finished, start the engine and test it's working appearance, eliminate the trouble and abnormal appearance.

### 3. Second grade technique maintenance

- 3.1 Perform the items on the "first grade technique maintenance"
- 3.2 Replace the oil, clean the oil sump and the oil strainer.
- 3.3 Clean the oil filter, replace the element.
- 3.4 Replace the oil in the air compressor.
- 3.5 Clean the fuel tank, oil delivery pump screen and pipe.  
clean the fuel filter element with clear fuel.
- 3.6 If the engine is supercharged type, then clean the cave and propeller impeller of the turbocharger air pump, and also test the moving and fasten parts.
- 3.7 Blow off the dust inside the dynamo with wompressed air. Check all parts, eliminate and abnormal parts.
- 3.8 Check and adjust the valve gap.
- 3.9 Check the injecting open pressure and it's spray quality of the injector, if need, to adjust it.
- 3.10 Fill the lubricating grease to the filling boles of the clutch, test the gap between the releasing lever and the releasing bearing.
- 3.11 Check and adjust the contact working gap and iron core gap every two maintenance period

### 4. Third grade technique maintenance

- 4.1 Perform the full items on the "second grade technique maintenance".
- 4.2 Clean the cooling system, wipe off the scale.

- 4.3 Clean the oil cooler.
- 4.4 Replace the air filter element and fuel filter element.
- 4.5 Dismantle and check the cylinder head. Test the valve seal, wipe off the carbon deposit, burnish the valve according the conditions.
- 4.6 Check the fasten situation of the cylinder head bolt, main bearing bolt, connecting rod bolt. For the bolts which tightening torque is insufficient, then tighten it to the set point value.
- 4.7 Check the water pump, replace the lubricating grease, if necessary, replace the water seal.
- 4.8 Check the dynamo, starting motor, clean, repair and fill new lubrication grease.
- 4.9 Check the injection pump, adjust the fuel lead angle, and adjust the injection pump according the conditions.
- 4.10 Test the air compressor, burnish the valve according the situation, and clean the carbon deposit.
- 4.11 Check the clutch, clean the inside dust deposit, oil dirt, and replace the lubricating grease.
- 4.12 Check the turbocharger, clean the parts, wipe off the carbon deposit, and test the rotor freedom allowance.

## 5. Technique maintenance on winter using

If the temperature maybe lower than 5°C, the engine must be maintained specially.

- 5.1 Must use the winter used oil and fuel, note the damp in the fuel so as to protect the fuel passage from being jammed.
- 5.2 It's better to fill the antifreeze fluid to the cooling system, or must drain off the cooling water after its temperature is lower than 40 – 50°C.
- 5.3 On the cold season or area, it's better to prevent the diesel engine (or vehicle) from being deposit in the open air, or when starting, it's need to heat the cooling water to preheat the engine body.

## CHAPTER V Troubleshooting

### 1. Start failures

Trouble cause and its feature	Remedy
1.1 Troubles in fuel system	1.1
(1) Jammed in the fuel s	(1) Dismantle and clean

(2) Air trapped in the fuel system

(2) Vent the air from the system with the fuel delivery pump, check whether there is leakage of fuel and air in the fuel pipes

(3) Delivery pump fails in delivering fuel or delivers brokenly

(3) Check and repair

(4) Injector sprays abnormally

(4) Check and adjust or replace the needle valve mate

1.2 insufficient compress pressure

1.2

(1) Piston ring and cylinder liner wear

(1) Check and replace worn parts

(2) Piston ring gumming

(2) clear off gumming

(3) Valve leaks

(3) Valve spring broken or elasticity weakens, valve lash is incorrect, valve seal is not good, eliminate the ault

(4) Temperature is low after end of compression

(4) Environmental temperature is low, use preheat starting method

1.3 Trouble in electric devices

1.3

(1) Battery is insufficient

(1) Recharging the battery to the specified point

(2) Connecting of electric devices is not good

(2) Check the tighten of the connection

(3) Starting motor on rotate or rotates insufficiently

(3) Check the starting motor

(4) Clutch of starting motor skids

(4) Check and repair the clutch of the starting motor

(5) Gear of starting motor can't inlay the flywheel gear - rim

(5) Find out the fault and eliminate it

2. Unsteady running of the engine

Remedy

Trouble cause and its feature

(1) Handle according to the (1), (2)

(1) Fault in fuel system

(3), (4) in the 1.1

(2) Too much water in fuel

(2) check the dampness in the fuel

(3) Leakage in fuel passage

(3) Check and eliminate the fault

- (4) Governor works abnormally
- (5) Cylinder blows by
- (6) Uneven fuel delivery to each cylinder

- ① Uneven fuel delivery to each cylinder in injection pump
- ② Injector sprays not well or the mate be choked
- ③ The plunger of the injection pump-worn out or the spring broken

- (4) Check and adjust the governor
- (5) Check the tightening torque of the cylinder head bolt and the seal of the cylinder head gasket

- (6) ① Check and adjust
- ② check the spray quality of the injector, replace the mate if necessary
- ③ Check and replace

### 3. Output is insufficient or drops suddenly

#### Trouble cause and its feature

- (1) Air filter choked
- (2) Valve spring or push rod broken
- (3) Valve lash is incorrect
- (4) Compress pressure is insufficient
- (5) Fuel delivery advance angle is incorrect
- (6) Air trapped in the fuel system or the system is choked
- (7) Fuel delivery is insufficient
- (8) Injector spray not well
- (9) Governor works abnormally
- (10) Engine overbeated
- (11) Too much carbon deposited inside the engine
- (12) Exhaust manifold not expedite

#### Remedy

- 1. Clean or replace filter element
- 2. Check and replace
- 3. Check and adjust
- 4. Handle according to 1. 2
- 5. Check and adjust
- 6. Handle according to (1), (2), (3) in 1. 1
- 7. Check the plunger of the injection pump and fuel outlet valve
- 8. Check, clean and adjust the pressure
- 9. Test and repair the governor
- 10. Test and repair the cooling system, wipe off the scale
- 11. Clean off the carbon deposit
- 12. Find out the fault and eliminate it.

### 4. Abnormal noise during engine operation

#### Trouble cause and its feature

- (1) Injecting time is too early to

#### Remedy

- 1. Adjust the fuel delivery advance

cause the rhythmic and clear metallic pounding noise be heard inside the cylinder.

angle

(2) Injecting time is too late to cause the grave and unclear noise is heard inside the cylinder.

2. adjust the fuel delivery advance angle

(3) Pounding noise can be heard inside the cylinder after the engine starts because of too large gap between the piston and cylinder liner, this noise gets lower along with the warming of the engine.

3. Check the cylinder clearance, replace the piston or cylinder liner

(4) Too large clearance between the piston pin and pinhole, clear and sharp sound, especially when idling.

4. Replace the parts, assure the stipulated gap

(5) Too large clearance between the main bearing and the con - rod bearing, parts pounding sound is heard when the engine speed drops suddenly, grave and strong sound when at low speed.

5. Replace the parts, assure the stipulated gap

(6) The axial gap of the crankshaft is too large, pounding noise when idling.

6. Replace the thrust plate, assure stipulated gap

(7) Valve spring broken, push rod bent, valve clearance too large and so on, disorderly sound or light and rhythmic pounding sound be heard inside the cylinder head cover.

7. Replace the parts, adjust valve gap

(8) Piston touches valve, metallic pounding sound can be heard beside the cylinder head

8. Check valve clearance and transmitting gear mark

(9) Too large gear clearance, pounding sound is heard at the gear case when the speed

9. Test the gear back lash, replace gear according to the situation



---

## 5. Abnormal exhaust smoke

When the engine works normally, the smoke color is light grey, when the load is higher at low time, its color is only dark grey, when the exhaust smoke is blue, white or black, then the smoke color is abnormal. Blue means burning oil; white means fuel fog no burns thoroughly inside the cylinder or water trapped inside the cylinder; black means injecting fuel too much to burn thoroughly. Trouble cause and its feature

### 5.1

#### Blue smoke

- (1) Lubricating oil flees, piston ring installed inversely, choked or worn out to badly
- (2) Clearance between valve and pipe hole too large

#### Remedy

- (1) Check piston ring and eliminate the fault
- (2) Replace the parts and assure the stipulated lash

---

### 5.2

#### White smoke

- (1) Fuel spray be atomized not well, fuel drips
- (2) too much water trapped in the fuel
- (3) Water trapped in the cylinder

#### Remedy

- (1) Check the injection pressure and the seal of the mate, adjust and clean or replace
- (2) Test the fuel quality
- (3) Inspect the seal of the cylinder gasket, check the water leakage of the cylinder head and cylinder liner, repair or replace

---

### 5.3

#### Black smoke

- (1) Engine is over-loaded

#### Remedy

- (1) Adjust to the stipulated load

- |   |  |
|---|--|
| (2) Fuel sprays too much                              | (2) Adjust the fuel delivery amount of the fuel injection pump |
| (3) Injecting time is too late, late burning is heavy | (3) Adjust the fuel delivery advance angle                     |
| (4) Valve lash is incorrect or valve seal is not good | (4) Adjust the valve lash and seal, eliminate the fault        |
| (5) Air filter choked                                 | (5) Clean the filter element                                   |

#### 6. Insufficient oil pressure

##### Trouble cause and its feature

##### Remedy

- |  |  |
|--|--|
| 1. Oil pressure gauge is in trouble or the connecting pipe choked      | 1. Replace the pressure gauge or dredge the passage  |
| 2. Too little oil in the sump  | 2. Fill oil to the stipulated level  |
| 3. Too thin oil  | 3. Inspect oil grade, check whether the oil be thinned out with fuel or oil temperature too high, eliminate it |
| 4. Oil pump driving and driven gear worn out                           | 4. Replace driving and driven gear   |
| 5. Strainer screen and oil filter element blocked                      | 5. Clean or replace  |
| 6. Pressure limiting valve and pressure regulating valve spring broken | 6. Inspect and replace   |
| 7. Oil passage choked or oil leaks                                     | 7. Check and eliminate   |
| 8. Lash between the bearings too large                                 | 8. Test the matching lash  |

#### 7. Oil temperature too high

##### Trouble cause and its feature

##### Remedy

- |                                    |  |
|------------------------------------|--|
| 1. Engine is over-loaded           | 1. Adjust the load                                 |
| 2. oil is insufficient or overmuch | 2. Add or reduce the oil according the stipulation |
| 3. Piston ring leaks heavily       | 3. Replace piston ring or cylinder liner           |
| 4. Oil cooler choked inside, dirt  | 4. Check and clean                                 |

deposited outside, influence the heat radiating efficiency

---

8. The temperature of used cooling water too high

Trouble cause and its feature	Remedy
1. Water temperature gauge or inductor be in trouble	1. Inspect and replace
2. Cooling water is not enough	2. Fill cooling water and get rid of the air from the water passage
3. Flow of cooling water is too small	3.
(1) Flow of water pump is too small	(1) Check the lash of the water impellers , adjust the tension of the fan belt
(2) Too much scale deposit inside the engine	(2) Wipe off the scale deposit
4. The efficiency of radiator is not well	4. Clean off the dirt and scale deposit
5. Engine is over – loadedp	5. Adjust to the stipulated load

---

9. Trouble in the injection pump

Trouble cause and its featurep	Remedy
1. No fuel delivery	1.
(1) Fuel deliver pump is out of order	(1) Process according 10.
(2) Fuel filter or fuel passage is choked	(2) Clean or peplace
(3) Air trapped in fuel passage	(3) Wipe off air
(4) Fuel outletyp Valve Spring broken	(4) Replace spring
2. Fuel delivery uneven	2.
(1) Air trapped in fuel passage	(1) Wipe off air
(2) Fuel outlet valve spring broken	(2) Replace spring
(3) Seal face and outer face worn out	(3) Repair or replace
(4) Plunger mate worn out or spring broken	(4) Replace parts
(5) Plunger choked with impuritytp	(5) Clean

- (6) Pressure of inlet fuel is uneven
3. Insufficient fuel delivery
- (1) Fuel cock leaks
- (2) Connector of fuel pipe leaks
- (3) Plunger worn out

- (6) Inspect fuel delivery pump and filter
3. (1) Replace parts
- (2) Tighten the connector
- (3) Replace parts

10. Insufficient fuel supply of the fuel delivery pump

- |   |   |
|---|---|
| 1. Non – return spring broken or seal of the valve seat is not good | 1. Replace spring or repair non – return valve                      |
| 2. Piston worn out  | 2. Replace piston   |
| 3. Fuel inlet pipe leaks or choked                                  | 3. Check the seal of the pipes, tighten the screw, dredge the pipes |

11. Injector malfunction

Trouble cause and its feature

Remedy

- |  |   |
|--|---|
| 1. Spray less or no spray                      | 1.  |
| (1) Air trapped in the fuel passage            | (1) Blow off air                              |
| (2) Needle is blocked                          | (2) Repairing or replace                      |
| (3) Loose combination of the needle valve      | (3) Replace                                   |
| (4) Heavy leakage in fuel system               | (4) Tighten connector or replace parts        |
| (5) Abnormal fuel supply of the injection pump | (5) Inspect fuel supply of the injection pump |
| 2. Injecting pressure is low                   | 2. Add suitable thick washer                  |
| Pressure adjustment washer worn out            |   |
| 3. Too high injecting pressure                 | 3.  |
| (1) Needle valve blocked                       | (1) Clean or replace                          |
| (2) Injecting hole choked                      | (2) Clean                                     |
| (3) Pressure adjusting washer is too thick     | (3) Adjust the pressure adjusted washer       |
| 4. Too much of fuel leakage                    | 4.  |
| (1) Needle valve blocked                       | (1) Repair or replace                         |
| (2) Needle valve blocked                       | (2) Clean or replace                          |
| (3) Pressing cap is loose or distorted         | (3) Tighten, replace parts                    |

- |  |                            |
|--|----------------------------|
| (4) Fuel inlet and outlet connector screw is loose | (4) Tighten, replace parts |
| 5. Fuel atomized not well                          | 5.                         |
| (1) Needle valve is distorted or worn out          | (1) Replace                |
| (2) Bad seal of the needle valve                   | (2) Repair or replace      |
| (4) Needle valve blocked                           | (4) Clean or replace       |

## 12. Governor malfunction

Trouble cause and its feature	Remedy
1. Unsteady speed	1.
(1) Too large of camshaft axle lash	(1) Readjust
(2) Cylinders fuel supply uneven to much	(2) Readjust
(3) Fly - weight assembly installed improperly , too large stagger of fly hammer bracket shaft	(3) Recheck and assemble
(4) Fuel cock worn out or bad seal	(4) Repair or replace
2. Too high idling speed	2.
(1) Operating handle lever no reaches its position	(1) Inspect and adjust
(2) Tooth rod is not flexible	(2) Readjust or repair
3. Speed floating	3.
(1) Speed adjusted spring distorted	(1) Replace the speed adjusted spring
(2) Fly hammer assembly loosened	Check and tighten
(3) Too large friction resistance inside the governor	(3) Repair and eliminate
(4) Too Large axle lash of the injection pump camshaft	(4) Readjust
4. Overrunning of the engine	4.
(1) Tooth rod is not flexible	(1) Readjust and repair
(2) Lubricated not well, shaft sleeve of the governor burned out.	(2) Check and repair
(3) Fly hammer assembly loosened	(3) check and tighten
(4) high speed limit screw loosened	(4) Readjust

---

### 13. Engine stops suddenly

#### Trouble cause and its feat

#### Remedy

1. Crankshaft can't be rotated after the engine shtops

1.

(1) Crankshaft jammed with bushing

(1) Inspect, replace parts

(2) Piston jammed with cylinder liner

(2) Inspect, replace parts

2. Crankshaft can be rotated easily

2.

(1) Air trapped in fuel system

(1) Blow out air

(2) Fuel system choked

(2) Clean

(3) Air filter choked

(3) Maintenance the air filter

---

### 14. Charged dynamo out of order

#### Trouble cause and its feature

#### Remedy

1. Can't be charged at all

1.

(1) Open circuit or short circuit, , circuit cnnecting wrong

(1) Check the circuit connecting

(2) Dynamo claw loosened, rotor circuit opened, brus contacted badly

(2) Repair or check

(3) Dynamo silicon parts out of order

(3) Replace

2. Insufficient charging or charging unsteadily

2.

(1) Brush contacts badly, insufficient spring pressure, oil dirt on slip ring

(1) Check and repair

(2) Transmitting V - belt loosened

(3) Some silicon parts open circuited

3. Abnormal sound when working

(2) Adjust the tension of V - belt

(1) Dynamo bearing worn out

(3) Replace

(2) Installed improperly

3.

(3) Shout circuit inside the stator coil or parts shout circuited

(1) Replace

(2) Adjust

(3) Repair

---

## 15. Starting motor malfunction

Trouble cause and its feature

Remedy

### 1. Starting motor no works

1.

(1) Connecting electric wire con -  
tacts badly

(1) Clean and tighten the contacting  
point

(2) Insufficient charging of the bat -  
tery

(2) Recharging

(3) Brush contacts badly

(3) Clean the contacting surface of the  
commutator

(4) Open circuited inside the start -  
ing motor itself

(4) Repair

### 2. Starting motor rotates weakly

2.

(1) Bearing bush worn out

(1) Replace bearing bush

(2) Brush contacted badly

(2) Clean the contacting surface of the  
commutator

(3) Connecting electric wire con -  
tacted badly

(3) Clean and tighten the contacting  
point

(4) Switch contacted badly

(4) Inspect switch

(5) Insufficient charging of the bat -  
tery or its capacity is too small

(5) Recharging or replace large capacity  
battery

(6) Clutch clips

(6) Repair clutch

### 3. Gear returns hardly

3.

(1) Switch contacting slice burning -  
out and cemented

(1) Repair switch

---

## 16. Governor in trouble

Trouble cause and its feature

Remedy

### 1. No generating electricity at all

1.

(1) Too low of regulating voltage

(1) Inspect and adjust

(2) Connecting wrong

(2) Inspect the connecting

(3) Relay coil worn out, contacting  
point contacted badly

(3) Repair

### 2. Charging insufficiently or unsteadily

2.

- |  |                        |
|--|------------------------|
| (1) Too low of adjusting voltage                           | (1) Inspect and adjust |
| (2) Too dirty of contacting point                          | (2) Clean              |
| 3. Overchargin   | 3.                     |
| (1) Adjusting voltage too high or unadjusted, uncontrolled | (1) Inspect and adjust |
- 

17. Turbocharger in trouble

Trouble cause and its feature	Remedy
1. Engine output drops	1.
(1) Passage of air filter or air pump dirty	(1) Clean
(2) Leakage at the connector of the air pump body	(2) tighten
(3) Leakage at the air inlet connector	(3) Tighten
(4) Air inlet passage of the turbine be choked or dirty	(4) Clean
(5) Floating bearing worn out	(5) Replace
2. Black or blue smoke	2.
(1) Passage of air filter or air pump dirty	(1) Clean
(2) Altitude or temperature too high	(2) Adjust output
(3) Fuel return pipe of the turbocharger choked	(3) Wipe out
3. Abnormal noise inside the turbocharger	3.
(1) Pounding sound	(1) Check and repair
(2) Foreign matter enters into impeller or impeller be worn out	(2) Dismantle, inspect and repair
(3) Seal ring burned out	(3) Replace
4. Rotor rotates not flexibly	4.
(1) Leakage of turbocharger causes carbon deposited	(1) Clean
(2) Floating bearing worn out	(2) Replace



- |   |             |
|---|-------------|
| (3) Over – heating causes parts be transmuted | (3) Replace |
| (4) Precision of running balance too low      | (4) Replace |
- 

**18. Air compressor in trouble**

**Trouble cause and its feature**

**Remedy**

- |   |   |
|---|---|
| 1. Efficiency gets worse because of carbon deposited on exhaust valve, valve spring broken or cylinder liner worn out | 1. Clean off carbon deposit, replace parts                    |
| 2. Oil mixes because of piston ring broken, cylinder liner worn out or oil return pipe choked                         | 2. Clean and repair, replace parts                            |
| 3. Abnormal sound can be heard when working because of shaft and bearing worn out or piston touches cylinder head     | 3. Check and repair, clean off carbon deposit, replace parts. |
- 

**19. Clutch in trouble**

**Trouble cause and its feature**

**Remedy**

- |  |  |
|--|--|
| 1. Clutch slips  | 1.   |
| (1) Friction disc worn out or burn out                               | (1) Replace friction disc  |
| (2) Oil dirt on friction disc  | (2) Clean off oil dirt on the friction disc, pressing plate and flywheel |
| 2. Clutch disconnects not completely                                 | 2.   |
| (1) Pressing lever worn out  | (1) Replace in time  |
| (2) Adjusting plate worn out   | (2) Replace in time  |
| (3) Connecting plate worn out  | (3) Replace in time  |
| (4) Disconnecting bushing pin hole and tree lever shaft pin worn out | (4) Replace in time  |

## CHAPTER VI Installation Instruction For Diesel Engine Generating Set

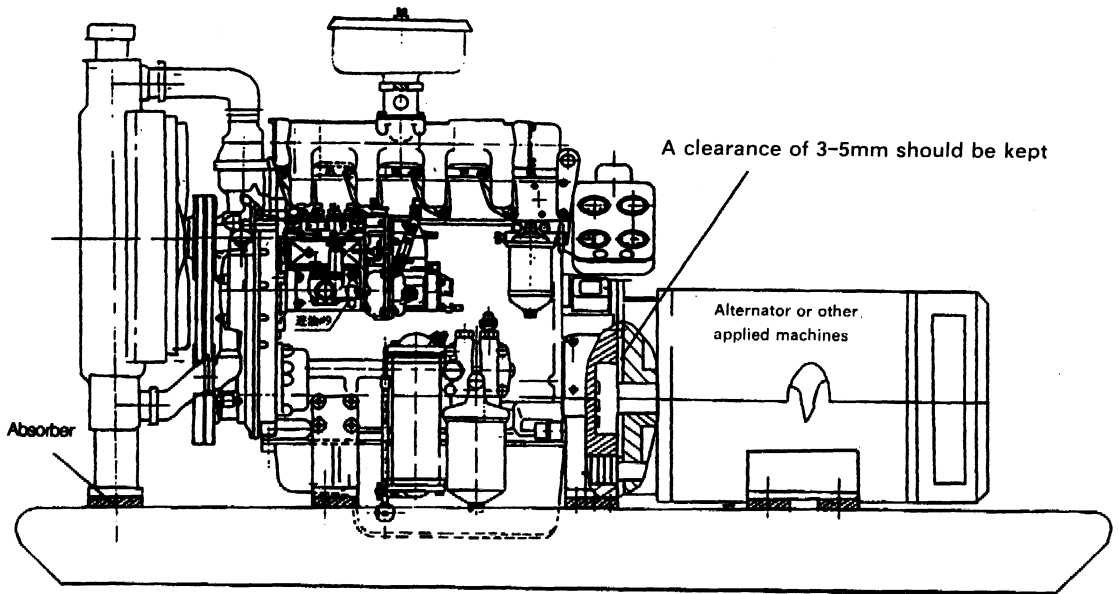

Fig. 21

### Attention:

1. The installation of cooling tank of the diesel engine should follow the structure of the layout. An absorber or damping gasket should be installed on the supporting section.
2. When the diesel engine is connected with alternator, air compressor etc. , if we adopt steel adaptor, an absorber or damping gasket should be installed on the supporting section.
3. When the diesel engine is connected with alternator, air compressor etc. , a clearance of 3 – 5mm should be kept between the diesel engine flywheel and the connecting disc of the applied machines in case the pull power or push power damage the diesel engine and the applied machines.
4. When the diesel engine and the applied machines are transmitted by V belt or flat belt, we shouldn't fasten the belt pulley on the flywheel or the gear box putout shaft directly, othorwise, it will damage the new crankshaft or bearing.
5. The diameter of the wind directing cover should match with the diameter of the fan. The diameters of the two have a difference of 20 – 40mm in general.

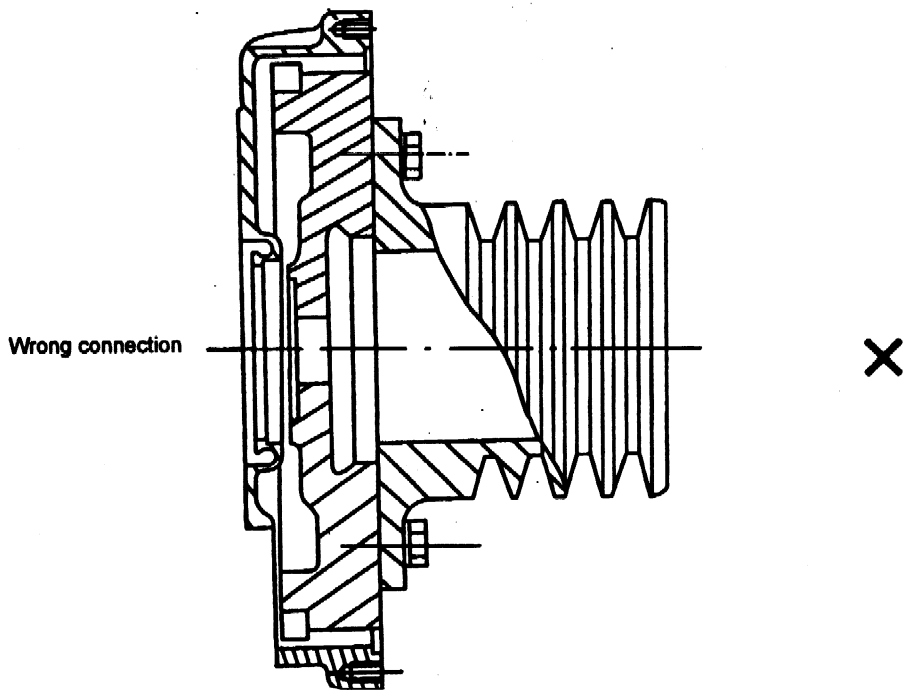
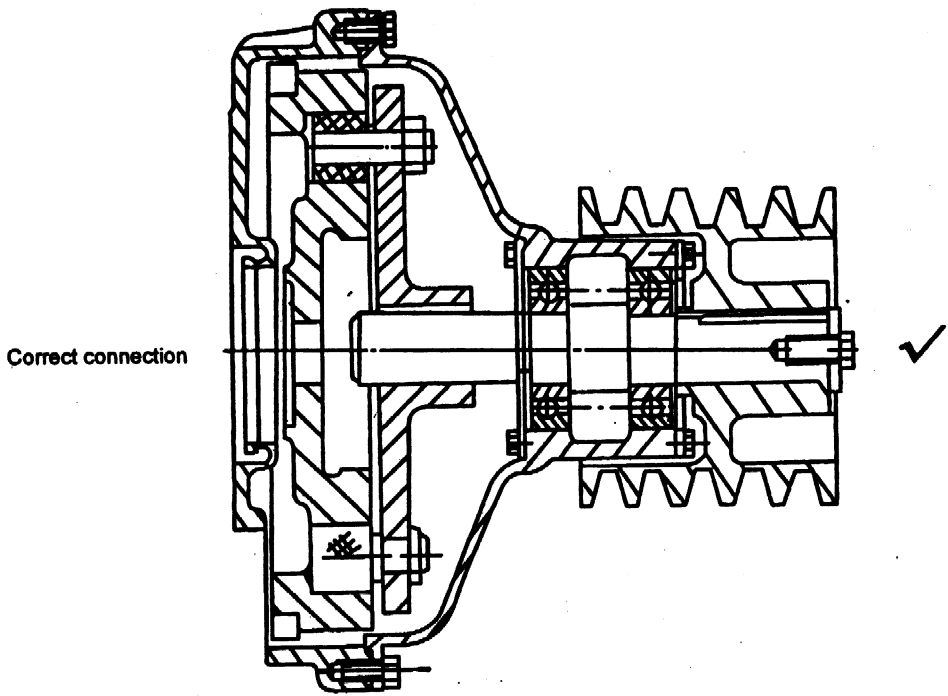

Fig. 22