

Ersatzteilkatalog
Spare Parts Catalogue
Catalogue de Pièces de Rechange
Catálogo de Piezas de Repuesto

BF 4L 2011

Motor-Nr: 1 011 154

Oktober 2004



Sehr geehrter Kunde,

Ihr Motor ist dem Einbaufall entsprechend ausgerüstet. Mit Hilfe der in dieser Ersatzteilliste grafisch dargestellten Motorbauteile können Sie das für Ihren Motor relevante Ersatzteil leicht herausfinden und die entsprechende Teilenummer bestimmen. Geben Sie zu Ihrer Bestellung auch immer die Motor-Nummer an. Damit ist gewährleistet, dass Sie über Ihren DEUTZ Service-Partner das aktuelle Originalteil erhalten, auch wenn im Rahmen der Weiterentwicklung der Motoren eine neue Teile-Nummer vergeben wurde.

Bitte beachten Sie, dass die grafischen Darstellungen stark vereinfacht sind und nur dem Erkennen dienen. Rückschlüsse aus geringfügigen Darstellungs-Unterschieden zum Originalteil sind nicht möglich.

Bei eventuellen Rückfragen wenden Sie sich bitte an Ihren DEUTZ Service Partner.

DEUTZ AG

Dear Customer,

Your engine has been fitted and designed to meet the requirements specific to its application. By referring to the illustration of the engine components shown in this spare parts list you will find it easy to select the appropriate spare part for your engine and to determine the relevant part number. When placing your order please be sure to quote the engine serial number. This will ensure that you receive the latest genuine part from your DEUTZ Service Partner, even when new part numbers are issued as the engines undergo further developments in the course of time.

Please note that the illustrations have been greatly simplified and are intended for identification purposes only. No inferences can be made from minor representational differences with regard to the genuine part.

Should you have any questions, please contact your DEUTZ Service Partner.

DEUTZ AG

Cher client,

Votre moteur est équipé conformément à son application. A l'aide des composants de moteurs représentés graphiquement dans cette documentation de pièces de rechange, vous pourrez facilement identifier la pièce de rechange voulue et le numéro de pièce correspondant. Indiquez toujours aussi, à chaque commande, le numéro du moteur. Vous aurez ainsi la certitude d'obtenir, par l'intermédiaire de votre partenaire de service DEUTZ, la pièce d'origine la plus récente, même si la pièce a changé de numéro dans le cadre du perfectionnement des moteurs.

Nous attirons votre attention sur ce que les graphiques sont fortement simplifiés et ne peuvent servir qu'à l'identification des pièces. De légères différences de représentation ne permettent pas de tirer des conclusions quant à la pièce d'origine.

Pour toute demande de précision, prière de vous adresser à votre partenaire de service DEUTZ.

DEUTZ AG

Estimado cliente:

Su motor ha sido equipado conforme a la aplicación a la que esté destinado. Los componentes del motor representados gráficamente en la presente lista de repuestos le ayudarán a identificar fácilmente la pieza correcta para su motor y a determinar el número de la misma. Al hacer el pedido, sírvase indicarnos, entre otros, siempre el número de su motor. De esta manera, tendrá la garantía de recibir a través de su Servicio DEUTZ la pieza original conforme al actual nivel técnico, aunque se le haya asignado otro número en el marco del constante desarrollo de los motores.

Por favor, tenga presente que las representaciones gráficas, muy simplificadas, sólo tienen la finalidad de poder identificar la pieza en cuestión. Por tanto, insignificantes diferencias en la representación no permiten sacar conclusiones con respecto a la pieza original.

En caso de dudas, póngase en contacto con su Servicio DEUTZ, que le ayudará gustosamente.

DEUTZ AG

1. Allgemeines	1. General	1. Généralités	1. Generalidades
2. Hinweise zur Ersatzteildokumentation	2. Information on spare parts documentation	2. Présentation de la Documentation de pièces de rechange	2. Indicaciones para la documentación de piezas de repuesto
2.1 Gegenüberstellungsverzeichnis (GV)	2.1 Cross-reference list (GV)	2.1 Liste des correspondances (GV)	2.1 Indice de identificación (GV)
2.2 Baugruppenverzeichnis (BG)	2.2 Index of construction groups (BG)	2.2 Liste des groupes constitutifs (BG)	2.2 Indice de grupos de construcción (BG)
2.3 Ersatzteilnummern-Listen-Blatt (ETL)	2.3 Spare parts number list sheet (ETL)	2.3 Feuille de liste des numéros de pièces de rechange (ETL)	2.3 Hoja de lista de números de piezas (ETL)
2.4 Teileverwendung(TVW)	2.4 Parts application(TVW)	2.4 Affectation des numéros de pièces (TVW)	2.4 Aplicación de piezas(TVW)
3. Hinweise zur Ersatzteilbestellung	3. Information on spare parts ordering	3. Etablissement de la commande de pièces de rechange	3. Indicaciones para pedidos de repuestos
3.1 Ersatzteilbestimmung	3.1 Spare parts identification	3.1 Identification des pièces de rechange	3.1 Identificación de piezas de repuesto
3.2 Bestellangaben	3.2 Ordering details	3.2 Renseignements à fournir dans la commande	3.2 Datos requeridos para pedidos de repuestos
4. Serviceorganisation	4. Service organization	4. Réseau de service après-vente	4. Organización de Servicio
5. Ersatzteildokumentation	5. Spare parts documentation	5. Documentation pièces de rechange	5. Documentación de piezas de repuesto

1. Allgemeines

DEUTZ Motoren

sind das Produkt jahrelanger Forschung und Entwicklung. Das dadurch gewonnene fundierte know how in Verbindung mit hohen Qualitätsanforderungen ist die Garantie für die Herstellung von Motoren mit langer Lebensdauer, großer Zuverlässigkeit und geringem Kraftstoffverbrauch. Es ist selbstverständlich, dass auch die hohen Anforderungen zum Schutz der Umwelt erfüllt werden.

Service

Wenden Sie sich bei Betriebsstörungen und Ersatzteilfragen an Ihren zuständigen DEUTZ Service-Partner. Unser geschultes Fachpersonal sorgt im Schadensfall für eine schnelle und fachgerechte Instandsetzung unter Verwendung von Original DEUTZ Teilen.

Original DEUTZ Teile

unterliegen den gleichen strengen Qualitätsanforderungen wie die DEUTZ Motoren. Weiterentwicklungen zur Verbesserung der Motoren werden selbstverständlich zeitgleich auch bei den Original DEUTZ Teilen eingeführt. Die Verwendung der nach neuesten Erkenntnissen gefertigten Original DEUTZ Teilen bietet die Gewähr einwandfreier Funktion und hoher Zuverlässigkeit.

Vorsicht bei laufendem Motor!



Wartungsarbeiten und Reparaturen nur bei abgestelltem Motor durchführen. Evtl. entfernte Schutzvorrichtungen müssen nach Abschluss der Arbeiten wieder montiert werden.

1. General

DEUTZ Engines

are the result of many years research and development work. The in depth expertise thus acquired together with high quality requirements are your guarantee for engines with a long service life, high reliability and low fuel consumption. It goes without saying that exacting environmental demands are also met.

Service

In the event of any malfunctions or should you have questions concerning spare parts, please contact your competent DEUTZ Service Partner. If damage has occurred, our trained technical staff will ensure rapid and appropriate repair using genuine DEUTZ parts.

Genuine DEUTZ parts

are subject to the same stringent quality requirements as the DEUTZ engines. You may rest assured that further developments for engine enhancement are simultaneously introduced for genuine DEUTZ parts. The use of genuine parts manufactured by applying state-of-the-art knowledge guarantees perfect function and high reliability.

Caution with running engine



Service and repair work should only be carried out with the engine switched off. Any guards and protective devices which have been removed during the course of such work should be fitted again once the work has been completed.

1. Généralités

Les moteurs DEUTZ

sont le fruit de longues années de recherches et de développement. Le solide savoir-faire ainsi acquis et nos exigences de qualité élevées garantissent la fabrication de moteurs de longue durée de vie, haute fiabilité et faible consommation de combustible. Il va de soi que les moteurs satisfont également aux exigences élevées en matière de protection de l'environnement.

Service

En cas d'incidents de fonctionnement et de questions relatives aux pièces de rechange, adressez-vous à votre partenaire de service DEUTZ. Notre personnel qualifié et spécialement formé assure, en cas d'incidents, une remise en état rapide, selon les règles de l'art, en utilisant les pièces d'origine DEUTZ.

Les pièces d'origine

sont soumises aux mêmes exigences de qualité sévères que les moteurs DEUTZ. Bien entendu, les pièces d'origine DEUTZ bénéficient simultanément aussi des développements réalisés dans le cadre du perfectionnement des moteurs. L'emploi de pièces d'origine fabriquées compte tenu des connaissances les plus récentes garantit un fonctionnement impeccable et une fiabilité élevée.

Attention sur moteur en marche!



N'effectuer des travaux d'entretien et de réparation que sur moteur arrêté. Les dispositifs de protection éventuellement enlevés, doivent être remontés après achèvement des travaux.

1. Generalidades

Los motores DEUTZ

son el producto de largos años de investigación y desarrollo. El fundado potencial tecnológico adquirido de esta manera, unido a las elevadas exigencias de calidad, es garantía para la fabricación de motores que se distinguen por longevidad, alta fiabilidad y bajo consumo de combustible. Se sobrentiende que también se cumplen las elevadas exigencias medioambientales.

Service

En caso de anomalías en el funcionamiento y cuestiones relacionadas con recambios, sírvase dirigirse a su Servicio DEUTZ. Nuestro personal técnico capacitado asegura, en caso de avería, la rápida y adecuada reparación de su motor, utilizando piezas originales DEUTZ.

Las piezas originales

están sometidas a los mismoselevados estándares de calidad que han de cumplir los motores DEUTZ. Desarrollos ulteriores para el mejoramiento de los motores son introducidos simultáneamente en las piezas originales DEUTZ. Sólo ella empleo-utilización de las piezas originales fabricadas según los métodos más modernos, garantiza un funcionamiento sin contratiempos y máxima fiabilidad.

Cuidado cuando el motor está en marcha!



No realizar trabajos de mantenimiento y reparaciones antes de parado el motor. Una vez finalizados los trabajos, es necesario montar de nuevo los dispositivos de protección que eventualmente se hubieran desmontado.

Hinweise zur Ersatzteildokumentation Information on spare parts documentation Présentation de la Documentation de pièces de rechange Indicaciones para la documentación de piezas de repuestos



2. Hinweise zur Ersatzteildokumentation

Die Ersatzteilliste enthält alle Ersatzteile für die im Titel genannten Motoren. Dabei können auch mehrere Motorvarianten zusammengefasst sein. Die Ersatzteildokumentation ist modular aufgebaut. Bei der Bestimmung des benötigten Ersatzteiles sind mehrere Arbeitsschritte erforderlich. Dabei ist grundsätzlich von der Motornummer auszugehen. Dadurch ist sichergestellt, dass Weiterentwicklungen berücksichtigt werden und der aktuelle Bauzustand der Original-Teile geliefert wird.

Die Motornummer ist auf dem am Motor befestigten Firmenschild und auf dem Kurbelgehäuse eingestempelt.

Die Ersatzteilliste ist keine Montageanleitung. Für den fachgerechten Einbau ist die entsprechende Werkstatt-Dokumentation (Werkstatt-Handbuch, Arbeitskarten) in der jeweils gültigen Fassung verbindlich.

2.1 Gegenüberstellungsverzeichnis (GV)

Motoren gleicher Ausführung sind unter einer Produktnummer zusammengefasst. Aus dem Gegenüberstellungsverzeichnis wird bei bekannter Motornummer die zugehörige Produktnummer (8-stellig plus 2 Index-Stellen, z.B. 0538 0764 / 02) ermittelt.

2. Information on spare parts documentation

The spare parts list covers all spare parts for the engines referred to in the title. Several engine versions may be combined in this information. The spare parts documentation has a modular structure. Several steps are necessary to identify the required spare part. Always start from the engine serial number. This will guarantee that further developments are taken into account and that the current production status of the genuine parts is supplied.

The engine serial number is stamped on the nameplate and on the crankcase.

The spare parts list is not a set of assembly instructions. For proper installation, the relevant workshop documentation (workshop hand-book, work cards) is binding in the valid version.

2.1 Cross-reference list (GV)

Engines with the same specification are combined under a common product number. If you know the engine serial number, you can determine the relevant product number (8-digit + 2 index digits, e.g. 0538 0764 / 02) taken from the cross-reference list. If the spare parts list only covers engines with

2. Présentation de la Documentation de pièces de rechange

La liste des pièces de rechange renferme toutes les pièces détachées pour les moteurs spécifiés dans l'en-tête. Plusieurs variantes de moteurs peuvent aussi être regroupées. La documentation de pièces de rechange est de présentation modulaire. L'identification de la pièce de rechange requise se fait en plusieurs phases. La base en est toujours le numéro du moteur.

Ceci garantit la prise en compte des développements récents et la fourniture de pièces d'origine de la dernière conception. Le numéro du moteur figure sur la plaque du constructeur fixée sur le moteur et est poinçonné sur le carter moteur.

La liste des pièces de rechange ne peut pas servir comme instructions de montage. Pour celles-ci se reporter à la documentation d'atelier (Manuel d'atelier, Cartes de travail) de la dernière édition.

2.1 Liste des correspondances (GV)

Les moteurs d'une même version sont regroupés sous le même numéro de produit. Dans la liste des correspondances GV, on détermine à partir du numéro de moteur connu, le numéro de produit correspondant (à 8 chiffres, plus deux chiffres d'indice, par exemple 0538 0764 / 02). Lorsque la liste des pièces

2. Indicaciones para la documentación de piezas derepuestos

La lista de repuestos contiene todas las piezas de recambio para los motores indicados en el título, pudiendo ser reunidas también varias variantes de motores. La documentación de piezas de repuesto está estructurada de forma modular. La identificación de la pieza requerida se efectúa en varios pasos y parte siempre del número de motor.

De esta manera queda garantizado que los desarrollos ulteriores sean considerados y las piezas originales suministradas correspondan al actual estado de construcción. El número de motor figura en la placa de fabricante fijada al motor y está troquelado también en el bloque motor mismo.

La lista de repuestos no comprende instrucciones de montaje. Para el montaje adecuado es de compromiso la correspondiente documentación de taller (manual de taller, fichas de trabajo) en la fecha respectiva.

2.1 Indice de identificación (GV)

Los motores de una misma versión han sido reunidos bajo un mismo número de producto. El índice de identificación (GV) sirve para identificar a través del número de motor conocido el correspondiente número de producto (8 cifras más dos cifras índice, p.ej. 0538 0764 / 02).

Gegenüberstellungsverzeichnis (GV) Motor-Nr -> Produkt-Nr. Cross-Reference (GV) engine S/N -> product no. Liste de correspondance (GV) no. moteur -> no. produit Indice de identificación (GV) no. de motor -> no. de producto				
Motor-Nr. Engine S/N No. Moteur No. de Motor	Produkt-Nr. No. produit No. de producto	Motor-typ engine model type moteur tipo de motor	Nennleistung rated power puissance nominale potencia nominal	Drehzahl rated speed régime velocidad
00402599	0543 9447 00	TD 520 GE	85,0 [kW]	1500 [1/min]
00402592	0543 9447 04	TD 720 GE	120,0 [kW]	1500 [1/min]
00505571	0543 9484 05	TD 720 GE	120,0 [kW]	1500 [1/min]
00505572	0543 9487 06	TAD 720 GE	153,0 [kW]	1500 [1/min]
00505573	0543 9487 05	TAD 720 GE	153,0 [kW]	1500 [1/min]
00507571	0543 9492 02	TAD 520 GE	102,0 [kW]	1500 [1/min]



Hinweise zur Ersatzteildokumentation Information on spare parts documentation Présentation de la Documentation de pièces de rechange Indicaciones para la documentación de piezas de repuesto

2.2 Baugruppenverzeichnis (BG)

Das Baugruppenverzeichnis ist eine Auflistung aller zu einer Produktnummer gehörenden Ersatzteilnummernlistenblätter. Es ist nach aufsteigender Baugruppennummer sortiert. Im Baugruppenverzeichnis sind max. 5 verschiedene Produktnummern nebeneinander dargestellt.

2.2 Index of construction groups (BG)

This is a listing of all spare parts number list sheets assigned to a specific product number. The listing is arranged by ascending construction group numbers. In the index of construction groups, up to 5 different product numbers are listed side by side.

2.2 Liste des groupes constitutifs (BG)

La liste des groupes constitutifs est une énumération de toutes les feuilles de liste des numéros de pièces de rechange appartenant à un numéro de produit. Elle est classée par ordre croissant des numéros de groupes constitutifs. La liste des groupes constitutifs présente au max. 5 numéros de produits différents juxtaposés.

2.2 Indice de grupos de construcción (BG)

En el Índice de grupos de construcción se relacionan todas las hojas de lista de números de pieza que correspondan a un número de producto. Los números de grupos de construcción están clasificados en orden ascendente. El Índice de grupos de construcción cubre a lo sumo cinco números de producto.

Baugruppenverzeichnis (BG) Index of ETL (BG) Index de ETL (BG) Índice de ETL (BG)																							
Teil/Piece/Folio: 11 12 2401 Teil/Piece/Folio: 11 10 1117																							
<table style="width: 100%; border-collapse: collapse;"> <tr> <td style="width: 30%; font-size: x-small;"> Produkt Nr. product no. No. produit No. de producto </td> <td style="text-align: right; font-size: large; font-weight: bold;">0542 6132/01</td> </tr> <tr> <td style="font-size: x-small;"> Baugruppe construction group groupe de construction grupo de construcción </td> <td style="text-align: right; font-size: large; font-weight: bold;">01</td> </tr> <tr> <td style="font-size: x-small;"> BEFESTIGUNGSTEILE FASTENINGS PIECES DE FIXAT. PIEZAS DE SUEGÓN FUEHRUNGSROHR GUIDE TUBE TUYAU DE GUIDAGE TUBO-CAJON D-RING/ALTERNENTEIL </td> <td style="vertical-align: bottom;"> <table style="width: 100%; border-collapse: collapse;"> <tr> <td style="font-size: x-small;">ETL:</td> <td style="font-weight: bold;">0507 036 1</td> </tr> <tr> <td style="font-size: x-small;">ETL:</td> <td style="font-weight: bold;">0507 049 1</td> </tr> </table> </td> </tr> </table>	Produkt Nr. product no. No. produit No. de producto	0542 6132/01	Baugruppe construction group groupe de construction grupo de construcción	01	BEFESTIGUNGSTEILE FASTENINGS PIECES DE FIXAT. PIEZAS DE SUEGÓN FUEHRUNGSROHR GUIDE TUBE TUYAU DE GUIDAGE TUBO-CAJON D-RING/ALTERNENTEIL	<table style="width: 100%; border-collapse: collapse;"> <tr> <td style="font-size: x-small;">ETL:</td> <td style="font-weight: bold;">0507 036 1</td> </tr> <tr> <td style="font-size: x-small;">ETL:</td> <td style="font-weight: bold;">0507 049 1</td> </tr> </table>	ETL:	0507 036 1	ETL:	0507 049 1	<table style="width: 100%; border-collapse: collapse;"> <tr> <td style="width: 30%; font-size: x-small;"> OELWAHNE OIL PAN CRATER A HUILE CRATER DE ACEITE </td> <td style="vertical-align: bottom;"> <table style="width: 100%; border-collapse: collapse;"> <tr> <td style="font-size: x-small;">ETL:</td> <td style="font-weight: bold;">0507 407 9</td> </tr> </table> </td> </tr> <tr> <td style="font-size: x-small;"> Baugruppe construction group groupe de construction grupo de construcción </td> <td style="text-align: right; font-size: large; font-weight: bold;">05</td> </tr> <tr> <td style="font-size: x-small;"> SCHWUNDRAD FLYWHEEL VOLANT VOLANTE BEFESTIGUNGSTEILE FASTENINGS PIECES DE FIXAT. PIEZAS DE SUEGÓN WHEELMOUNTING PART </td> <td style="vertical-align: bottom;"> <table style="width: 100%; border-collapse: collapse;"> <tr> <td style="font-size: x-small;">ETL:</td> <td style="font-weight: bold;">0507 477 9</td> </tr> <tr> <td style="font-size: x-small;">ETL:</td> <td style="font-weight: bold;">0507 606 8</td> </tr> </table> </td> </tr> </table>	OELWAHNE OIL PAN CRATER A HUILE CRATER DE ACEITE	<table style="width: 100%; border-collapse: collapse;"> <tr> <td style="font-size: x-small;">ETL:</td> <td style="font-weight: bold;">0507 407 9</td> </tr> </table>	ETL:	0507 407 9	Baugruppe construction group groupe de construction grupo de construcción	05	SCHWUNDRAD FLYWHEEL VOLANT VOLANTE BEFESTIGUNGSTEILE FASTENINGS PIECES DE FIXAT. PIEZAS DE SUEGÓN WHEELMOUNTING PART	<table style="width: 100%; border-collapse: collapse;"> <tr> <td style="font-size: x-small;">ETL:</td> <td style="font-weight: bold;">0507 477 9</td> </tr> <tr> <td style="font-size: x-small;">ETL:</td> <td style="font-weight: bold;">0507 606 8</td> </tr> </table>	ETL:	0507 477 9	ETL:	0507 606 8
Produkt Nr. product no. No. produit No. de producto	0542 6132/01																						
Baugruppe construction group groupe de construction grupo de construcción	01																						
BEFESTIGUNGSTEILE FASTENINGS PIECES DE FIXAT. PIEZAS DE SUEGÓN FUEHRUNGSROHR GUIDE TUBE TUYAU DE GUIDAGE TUBO-CAJON D-RING/ALTERNENTEIL	<table style="width: 100%; border-collapse: collapse;"> <tr> <td style="font-size: x-small;">ETL:</td> <td style="font-weight: bold;">0507 036 1</td> </tr> <tr> <td style="font-size: x-small;">ETL:</td> <td style="font-weight: bold;">0507 049 1</td> </tr> </table>	ETL:	0507 036 1	ETL:	0507 049 1																		
ETL:	0507 036 1																						
ETL:	0507 049 1																						
OELWAHNE OIL PAN CRATER A HUILE CRATER DE ACEITE	<table style="width: 100%; border-collapse: collapse;"> <tr> <td style="font-size: x-small;">ETL:</td> <td style="font-weight: bold;">0507 407 9</td> </tr> </table>	ETL:	0507 407 9																				
ETL:	0507 407 9																						
Baugruppe construction group groupe de construction grupo de construcción	05																						
SCHWUNDRAD FLYWHEEL VOLANT VOLANTE BEFESTIGUNGSTEILE FASTENINGS PIECES DE FIXAT. PIEZAS DE SUEGÓN WHEELMOUNTING PART	<table style="width: 100%; border-collapse: collapse;"> <tr> <td style="font-size: x-small;">ETL:</td> <td style="font-weight: bold;">0507 477 9</td> </tr> <tr> <td style="font-size: x-small;">ETL:</td> <td style="font-weight: bold;">0507 606 8</td> </tr> </table>	ETL:	0507 477 9	ETL:	0507 606 8																		
ETL:	0507 477 9																						
ETL:	0507 606 8																						

Hinweise zur Ersatzteildokumentation Information on spare parts documentation Présentation de la Documentation de pièces de rechange Indicaciones para la documentación de piezas de repuesto



2.3 Ersatzteilnummern- Listen-Blatt (ETL)

Die Ersatzteilnummern-Listen - Blätter bestehen aus je einem Bild- und Textteil. Alle ersatzteil-relevanten Teile sind isometrisch in Explosionsdarstellung in der oberen Blatthälfte dargestellt. Über die Positionsnummer können dem darunterliegenden Textteil die Teilenummer, benötigte Stückzahl, Benennung, sowie Normbezeichnungen und Hinweise entnommen werden.

Die Ersatzteilnummern-Listen-Blätter sind, wie im Beispiel angegeben, oben rechts benummert und nach Baugruppen geordnet. Innerhalb einer Baugruppe ist nach laufender Nr. sortiert.

2.3 Spare parts number list sheet (ETL)

The spare parts number list sheets each comprise a graphic section and a text section. The upper half of the sheet shows an exploded isometric view of all parts qualifying as spares. With the help of the item number, it is possible to take from the text section below the required quantity, description and any standards designations and relevant information.

The spare parts number list sheets are, as shown in the example, identified in the top right-hand corner and are arranged according to construction groups. Construction groups are subdivided according to serial number.

2.3 Feuille de liste des numéros de pièces de rechange (ETL)

Les feuilles de liste des numéros de pièces de rechange comprennent une partie illustrations et une partie texte. Toutes les pièces à caractère de rechange sont isométriquement représentées en vue éclatée dans la partie supérieure de la feuille. A l'aide du numéro de repère, on peut relever dans la partie texte située dessous, le numéro de pièce, la quantité requise, la désignation ainsi que des références de normes et d'autres indications.

Les feuilles de liste des numéros de pièces de rechange sont comme le montre l'exemple numérotées en haut et à droite et classées par groupes constitutifs. Au sein d'un groupe constitutif, le classement se fait par numéro courant.

2.3 Hoja de lista de números de pieza (ETL)

La hoja de una lista de números de pieza se compone de una parte ilustra y de otra con texto. Todas las piezas importantes para el recambio están representadas isométricamente en el dibujo de despiece de la parte superior de la hoja. El número de posición de la pieza permite deducir de la parte inferior de texto, el número, la cantidad y la denominación de la pieza. Así como denominaciones de norma y otras indicaciones.

Como se puede desprender del ejemplo, las hojas de lista de números de pieza llevan arriba a la derecha un número y están ordenadas por grupos de construcción. Dentro de cada grupo, el orden es por números correlativos.

**KURBELGEHÄUSE
CRANKCASE
CARTER
BLOQUE DE CILINDR.**

01 0506 8040

042

185

1 (2-19)

6

10

11

14

26

7

8

13

18 (19)

9

39

**Baugruppe
Construction group
Groupe constitutif
Grupo de construcción**

**Laufende Nummer
Serial number
Numéro courant
Número correlativo**

BILD FIG.	TN / PN	MGE QTY	DEUTSCH	ENGLISH	FRANÇAIS	ESPAÑOL
1	0417 2910	1	KURBELGEHÄUSE	ENGINE BLOCK	BLOC MOTEUR	CARTER CILINDR. NEUTEIL, AUSTAUSCHTEIL SIEHE POS. A KOMPL. MIT POS. (2-19) (A) 961 FL. M. STANDARD KOLBEN (A) 961 FL. M. ABGASOPTI. KOLBEN (A) 961 FM. M. STANDARD KOLBEN (A) 961 FM. M. ABGASOPTI. KOLBEN
2	0417 2155	2	LAGERBUCHSE	BEARING BUSH	BAGUE	CASQUILLO COJINETE
3	0417 2154	3	LAGERBUCHSE	BEARING BUSH	BAGUE	CASQUILLO COJINETE
4	0210 8055	2	FÜHRUNGSHUELSE	GUIDE SLEEVE	DOUILLE DE GUIDAGE	CASQUILLO GUIDA
5	0417 2741	1	VERSCHLUSSSCHRAUBE	SCREW PLUG	BOUTON FILETÉ	TAPON ROSADO

2.4 Teileverwendung (TVW)

Alle dokumentierten Ersatzteile sind den Ersatzteilnummern-Listen-Blättern gegenübergestellt. Damit können über die Teilenummern die Ersatzteilnummern-Listen-Blättern ermittelt werden, in denen das Teil enthalten ist.

2.4 Parts application (TVW)

All documented spare parts are assigned to the spare parts number list sheets. This enables you to determine via the part numbers the spare parts number list sheets where the part you are looking for is listed.

2.4 Affectation des numér. de pièces (TVW)

Toutes les pièces de rechange documentées renvoient aux feuilles de liste des numéros de pièces de re-change. A l'aide des numéros de pièce, il est ainsi possible de déterminer les feuilles de liste des numéros de pièces de rechange qui renferment la pièce voulue.

2.4 Aplicación de piezas (TVW)

Todas las piezas de repuesto documentadas están asignadas a las hojas de lista de números de pieza. De esta manera es posible identificar a través de los números de pieza las hojas de lista de números de pieza donde figuran las piezas buscadas.



Hinweise zur Ersatzteilbestellung Information on spare parts ordering Etablissement de la commande de pièces de rechange Indicaciones para pedidos de repuesto

3. Hinweise zur Ersatzteilbestellung

3. Information on spare parts ordering

3. Etablissement de la commande de pièces de rechange

3. Indicaciones para pedidos de repuestos

3.1 Ersatzteilbestimmung Bestimmung eines Ersatzteiles in Arbeitsschritten.

3.1 Spare parts identification Identification of a spare part in the following steps.

3.1 Identification des pièces de rechange Différentes phases d'identification d'une pièce de re-change.

3.1 Identificación de piezas de repuesto Identificación de una pieza de repuesto en distintos pasos.

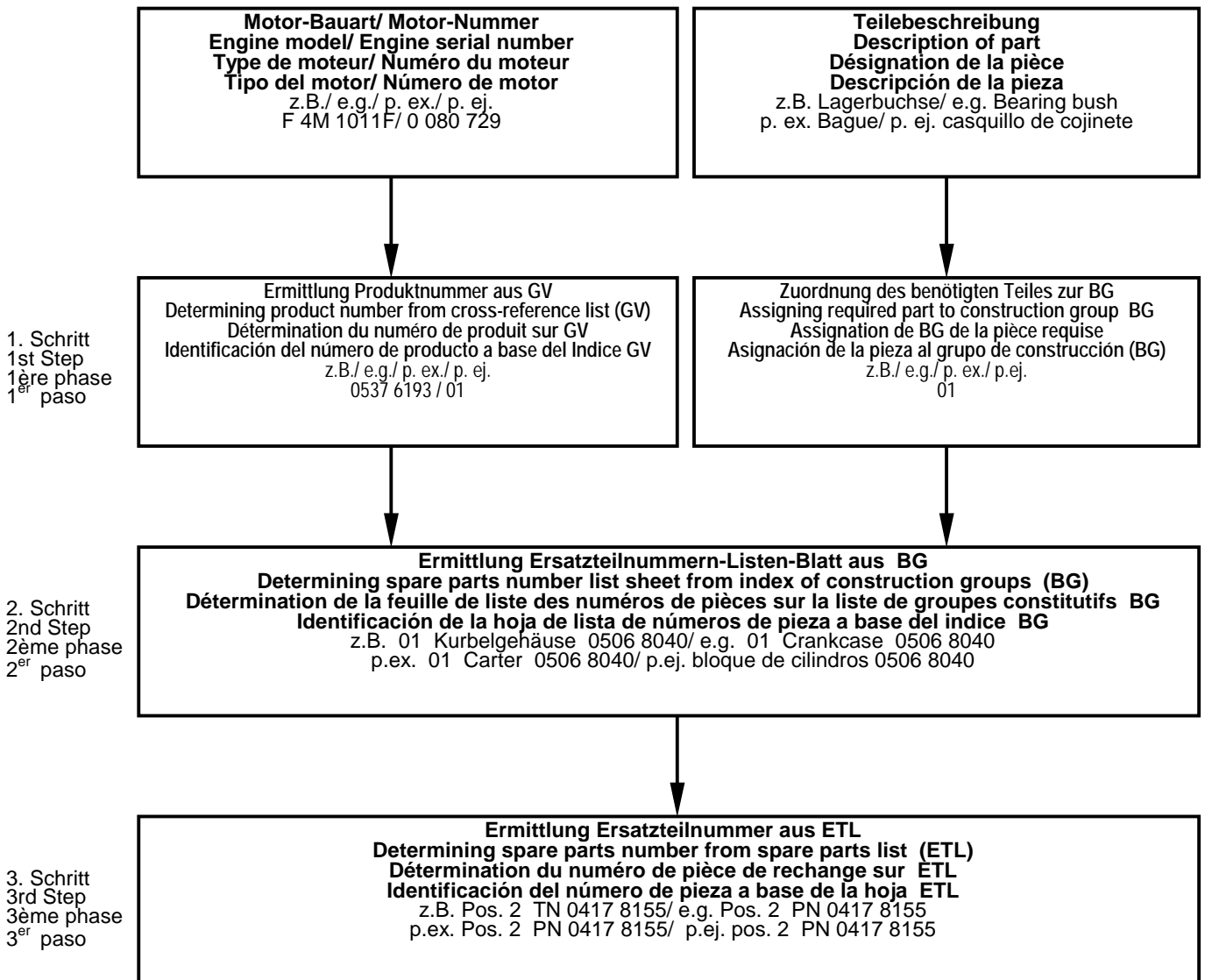

Hinweise zur Ersatzteilbestellung

Information on spare parts ordering

Etablissement de la commande de pièces de rechange

Indicaciones para pedidos de repuesto



3.2 Bestellangaben

Bei der Ersatzteilbestellung sind folgende Angaben erforderlich:

- Motor-Bauart
- Motor-Nummer
- Teilenummer
- Stückzahl

Über die Motor-Nummer wird sichergestellt, dass bei späteren Änderungen immer das für den Motor richtige Original-Teil geliefert wird.

3.2 Ordering details

Please give the following details when ordering spare parts:

- Engine model
- Engine serial number
- Part number
- Quantity

Quoting the engine serial number ensures that you always receive the correct genuine part for the relevant engine, even if subsequent changes are made.

3.2 Renseignements à fournir dans la commande

Pour la commande de pièces de rechange, les renseignements suivants sont requis:

- Type de moteur
- Numéro du moteur
- Numéro de pièce
- Quantité

L'indication du numéro du moteur assure qu'en cas de modifications ultérieures, il soit toujours fourni la pièce d'origine correcte pour le moteur.

3.2 Datos requeridos para pedidos de repuestos

Para un pedido de repuestos se necesitan los siguientes datos:

- el tipo del motor
- el número de motor
- el número de pieza
- la cantidad

A través del número de motor se asegura que, en caso de modificaciones posteriores, siempre se recibirá la correcta pieza original para el motor.

KURBELGEHÄUSE
CRANKCASE
CARTER
BLOQUE DE CILINDR.

Ersatzteilbestellung
Spare parts order
Commande de pièces de rechange
Pedido de repuestos

Motor-Bauart:
Engine model:
Type de moteur: **F4M 1011F**
Tipo del motor:

Motor-Nummer:
Engine serial number:
Numéro du moteur: **0 080 729**
Número de motor:

Lfd. Nr./Sec. No. No. cat./No. cat.	Stk./Qty. Qté./Cant.	Teilenummer/Part number No. de pieza/No. de pieza
1.	2	0417 8155
2.	3	0417 8154
3.	1	0210 8055

BILD FIG.	T&Z NR.	MAG. SYM.	DEUTSCH	ENGLISH	FRANCOIS
1	0417 8155	1	KURBELGEHÄUSE	CRANKCASE	BLOQUE DE CILINDR.
2	0417 8155	1	LÄNGERBLOCH	DRAWING BUSH	BUSH
3	0417 8154	3	LÄNGERBLOCH	DRAWING BUSH	BUSH
4	0210 8055	1	PUMPENGEHÄUSE	PUMP HOUSING	BOITIER DE LA POMPE
5	0417 8141	1	VERGELLSCHRAUBE	SCREW PL. 42	BOUTON FILETÉ



<p>4. Serviceorganisation</p> <p>Zu wissen, es ist DEUTZ.</p> <p>Seit jeher steht DEUTZ für bahnbrechende Entwicklungen im Motorenbau. Als unabhängiger Motorenhersteller bieten wir weltweit eine komplette Palette von Diesel- und Gasmotoren im Leistungsbereich von 4 bis 7.400 kW an. Unsere Produkte sind auf die Anforderungen unserer Kunden perfekt zugeschnitten.</p> <p>Weltweit verrichten mehr als 1,4 Millionen DEUTZ Motoren zuverlässig ihren Dienst. Die Einsatzbereitschaft unserer Motoren und damit die Zufriedenheit unserer Kunden wollen wir erhalten. Daher sind wir weltweit mit einem Netz von kompetenten Partnern vertreten, dessen Dichte der regionalen Verteilung unserer Motoren entspricht.</p> <p>So ist DEUTZ nicht nur der Name für Motoren mit Erfindungsgeist. Sondern auch für ein komplettes Leistungspaket rund um den Motor und einen Service, auf den Sie sich verlassen können.</p> <p>Das Register Sales & Service bietet Ihnen einen Überblick über die DEUTZ Partner in Ihrer Nähe, über deren Produkt-Zuständigkeiten und Service-Leistungen. Aber auch wenn keine direkte Produkt-Zuständigkeit vermerkt ist, hilft Ihnen der DEUTZ Partner mit kompetenter Beratung weiter.</p> <p>Das Register wird permanent aktualisiert; fragen Sie Ihren DEUTZ Partner nach der neuesten Auflage.</p> <p>Ihre Deutz AG</p>	<p>4. Service organization</p> <p>Knowing it's DEUTZ</p> <p>DEUTZ has always stood for excellence in motor construction, pioneering many developments in the industry. As an independent engine manufacturer, we offer a comprehensive range of diesel and gas engines worldwide, from 4kW to 7,400kW. Our products are perfectly tailored to meet our customers' individual requirements.</p> <p>Over 1.4 million DEUTZ engines do their job reliably all over the world. We are determined to preserve the high standard of performance and dependability of our engines, thus keeping our customers satisfied at all times. We are therefore represented worldwide through a network of highly competent service partners who meet the needs of our customers, wherever they are.</p> <p>This is why DEUTZ is not only the name for engines which pack a lot of inventive genius. DEUTZ also means reliable service and comprehensive support to enhance your engine's performance.</p> <p>This Sales & Service index gives you an overview of the DEUTZ partners in your vicinity, including the products for which they are responsible and the range of services provided. But even when no direct product responsibility is mentioned, your DEUTZ partner will be pleased to help you with expert advice.</p> <p>The index is constantly updated. Please ask your DEUTZ service partner for the latest edition.</p> <p>DEUTZ AG at your service.</p>	<p>4. Réseau de service après-vente</p> <p>Qu'on se le dise: c'est du DEUTZ!</p> <p>DEUTZ est depuis toujours synonyme d'innovation dans le domaine de la construction de moteurs. C'est un fabricant indépendant qui offre une gamme complète de moteurs diesel et à gaz d'une puissance de 4 à 7 400 kW sur l'ensemble de la planète. Nous fournissons des produits parfaitement adaptés aux exigences de nos clients.</p> <p>Aujourd'hui, plus de 1,4 million de moteurs DEUTZ tournent dans le monde entier. Notre double objectif est d'assurer la fiabilité de nos moteurs et de garantir la satisfaction de nos clients. C'est pourquoi nous sommes représentés aux quatre coins de la planète par un réseau de partenaires compétents qui correspond à la répartition régionale de nos moteurs.</p> <p>DEUTZ, ce n'est donc pas seulement une marque innovatrice de moteurs. C'est aussi une gamme complète de services autour du moteur, c'est aussi un nom sur lequel vous pouvez toujours compter.</p> <p>Le registre Sales & Service vous donne un aperçu des partenaires DEUTZ les plus proches, de leurs compétences techniques et des services qu'ils vous offrent. Et même s'il n'est pas directement spécialisé dans le produit qui vous intéresse, votre partenaire DEUTZ pourra vous conseiller avec compétence.</p> <p>Le registre est constamment actualisé. N'hésitez pas à demander la dernière version en date à votre partenaire DEUTZ.</p> <p>Votre DEUTZ AG</p>	<p>4. El servicio de DEUTZ AG</p> <p>La confianza de saber que es DEUTZ</p> <p>DEUTZ siempre ha estado a la vanguardia de la industria de fabricación de motores. Como marca independiente, ofrecemos, a escala mundial, una gama muy completa de motores diesel y de gas, con potencias comprendidas entre 4kW y 7400kW. Nuestros productos están estudiados para satisfacer plenamente las exigencias de nuestros clientes.</p> <p>Más de 1.400.000 motores DEUTZ funcionan con toda fiabilidad en distintas partes del mundo. Estamos resueltos a mantener las elevadas prestaciones de nuestros motores y, por consiguiente, la confianza y satisfacción de nuestros clientes. Por ello, contamos con una red mundial de centros de asistencia, cuya densidad corresponde a la distribución de motores en las distintas regiones.</p> <p>Así pues, DEUTZ no es tan sólo el nombre de un motor fruto del genio creador. DEUTZ también significa un paquete de servicios de apoyo para garantizar un funcionamiento óptimo del motor y una asistencia técnica en la que puede Ud. confiar.</p> <p>El registro Ventas y Servicio le ofrece una panorámica de los centros DEUTZ en su zona geográfica, detallando, en particular, los productos de los que se ocupa cada centro y la gama de servicios disponibles. Pero incluso cuando no se mencione un producto determinado, puede Ud. estar seguro que su centro de asistencia DEUTZ tendrá mucho gusto en asesorarle y ayudarle en todo lo que pueda.</p> <p>El registro se actualiza periódicamente. No dude en solicitar la última edición a su centro de asistencia DEUTZ.</p> <p>DEUTZ AG a su servicio.</p>
---	---	--	---

**Bestell-Nr.:
Order No.:
Réf. de Cde:
No. Pedido:**

0297 7444



0297 7445 (CD)

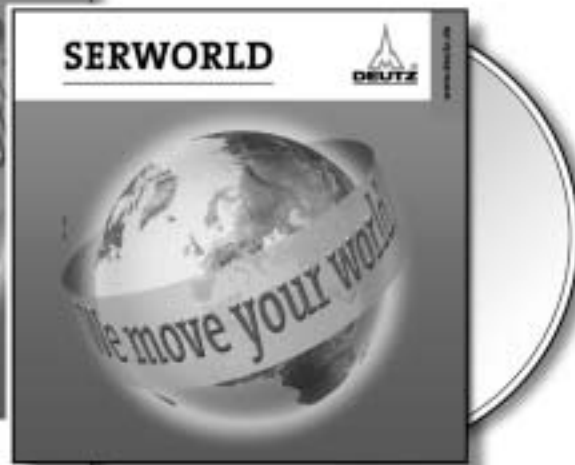

Beziehbar über Ihren zuständigen Service-Partner vor Ort oder bei:

Obtainable from the local service partner responsible for you or from:

A commandé auprès de votre partenaire SAV local ou de:

Obtenible a través de su servicio local correspondiente o de:

DEUTZ AG
Deutz-Mülheimer Str. 147-149
D-51057 Köln

DEUTZ AG
Deutz-Mülheimer Str. 147-149
D-51057 Köln

DEUTZ AG
Deutz-Mülheimer Str. 147-149
D-51057 Köln

DEUTZ AG
Deutz-Mülheimer Str. 147-149
D-51057 Köln

Telefon: 0049-221-822-0
Telefax: 0049-221-822-5358
Telex: 8812-0 khd d
<http://www.deutz.de>

Phone: 0049-221-822-0
Telefax: 0049-221-882-5358
Telex: 8812-0 khd d
<http://www.deutz.de>

Téléphone: 0049-221-822-0
Téléfax: 0049-221-822-5358
Téléc: 8812-0 khd d
<http://www.deutz.de>

Teléfono: 0049-221-822-0
Telefax: 0049-221-822-5358
Telex: 8812-0 khd d
<http://www.deutz.de>

5. Ersatzteildokumentation 5. Spare parts documentation 5. Documentation pièces de rechange 5. Documentación de piezas de repuesto



KURBELWELLE
CRANKSHAFT
VILEBREQUIN
CIGUENAL

05 0506 8138



OELWANNE
OIL PAN
CARTER A HUILE
CARTER DE ACEITE

02 0506 7623



KURBELGEHAEUSE
CRANKCASE
CARTER
BLOQUE DE CILINDR.

01 0506 8040

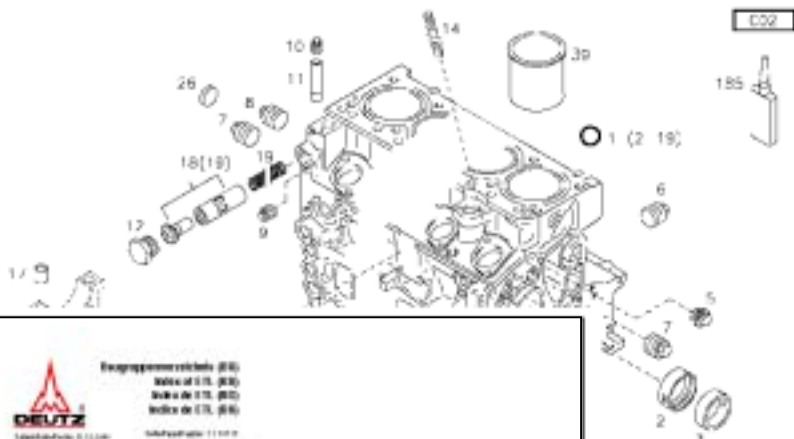



Emparejamiento cilindro (Ø)
Index of Cyl. (Ø)
Index de Cyl. (Ø)
Index de Cyl. (Ø)

Identificación 0506 8132/01

01

DEUTZ
FESTENAGG
PIEDRE DE PIEDR.
PIEDRE DE PIEDR.
PIEDRE DE PIEDR.
PIEDRE DE PIEDR.
PIEDRE DE PIEDR.
PIEDRE DE PIEDR.
PIEDRE DE PIEDR.



Gegenüberstellungsverzeichnis (GV) Motor-Nr. → Produkt-Nr.
Cross-Reference (GV) engine S/N → product no.
Liste de correspondance (GV) no. moteur → no. produit
Indice de identificación (GV) no. de motor → no. de producto

Motor-Nr. Engine S/N No. Motor No. de Motor	Produkt-Nr. Product No. No. produit No. de producto	Abbildung Drawing Représentation Representación	Abbildung Drawing Représentation Representación	Abbildung Drawing Représentation Representación
0506001	0506001	10-10-10	10-10-10	10-10-10
0506002	0506002	10-10-10	10-10-10	10-10-10
0506003	0506003	10-10-10	10-10-10	10-10-10
0506004	0506004	10-10-10	10-10-10	10-10-10
0506005	0506005	10-10-10	10-10-10	10-10-10
0506006	0506006	10-10-10	10-10-10	10-10-10
0506007	0506007	10-10-10	10-10-10	10-10-10
0506008	0506008	10-10-10	10-10-10	10-10-10
0506009	0506009	10-10-10	10-10-10	10-10-10
0506010	0506010	10-10-10	10-10-10	10-10-10



Gegenüberstellungsverzeichnis (GV) Motor-Nr -> Produkt-Nr.
Cross-Reference (GV) engine S/N -> product no.
Liste de correspondance (GV) no. moteur -> no. produit
Indice de identification (GV) no. de motor -> no. de producto

Datum/Date/Fecha: 27.10.2004

Seite/Page/Pagina: 1 / 1

Motor-Nr. Engine S/N No. Moteur No. de Motor	ETL-Umfang product no. No. produit No. de producto	Motortyp engine model type moteur tipo de motor	Nennleistung rated power puissance nominal potencia nominal	Drehzahl rated speed régime velocidad
000001011154	EU305963	BF04L2011	58,0 [kW]	2800 [1/min]



Baugruppenverzeichnis (BG)
Index of ETL (BG)
Index de ETL (BG)
Indice de ETL (BG)

Datum/Date/Fecha: 27.10.2004

Seite/Page/Página: 1 / 5

ETL-Umfang.
product no.
No. produit
No. de producto

EU305963

Baugruppe
construction group
groupe de construction
grupo de construcion

01

OELMESSSTAB
DIPSTICK
ETL:
0507 7818

JAUGE D.PROFONDEUR
SONDA DE ACEITE

ZYL.KURBELGEHAEUSE
ENGINE BLOCK
BLOC-MOTEUR
ETL:
0507 9161

BLOQUE D.CILINDROS

HINTERER DECKEL
REAR END COVER
ETL:
0507 9188

COUVERCLE ARRIERE

TAPA TRASERA

KURB.GEH.ENTLUEFT.
CRANKCASE BREATHER
ETL:
0507 4210

RENIFLARD

DESAIREAC. BLOQUE

Baugruppe
construction group
groupe de construction
grupo de construcion

02

OELWANNE
OIL PAN
ETL:
0506 9057

CARTER A HUILE

CARTER DE ACEITE

Baugruppe
construction group
groupe de construction
grupo de construcion

05

KRAFTABNAHME
POWER TAKE-OFF
ETL:
0505 1754

PRISE DE MOUVEMENT

TOMA DE FUERZA

KURBELWELLE
CRANKSHAFT
ETL:
0506 8138

VILEBREQUIN

CIGUENAL

SCHWUNGRAD
FLYWHEEL
ETL:
0507 4151

VOLANT

VOLANTE

ANBAUTEILE
ACCESSORIES
ETL:
0507 4230

ACCESSOIRES

PIEZAS DE MONTAJE

Baugruppe
construction group
groupe de construction
grupo de construcion

06

PLEUELSTANGE
CONNECTING ROD
ETL:
0507 7880

BIELLE

BIELA

Baugruppe
construction group
groupe de construction
grupo de construcion

07

KOLBEN
PISTON
ETL:
0507 7922

PISTON

PISTON

Baugruppe
construction group
groupe de construction
grupo de construcion

08

VENTILANTR.HAUBE
VALVE MECHAN.COVER
ETL:
0506 9155

CAPOT DE CULBUTEUR

TAPA DE BALANCINES

ZYLINDERKOPF
CYLINDER HEAD
ETL:
0507 4211

CULASSE

CULATA

BEFESTIGUNGSTEILE
FASTENINGS
ETL:
0507 7836

PIECES DE FIXAT.

PIEZAS DE SUJECION

EINFUELLVERSCHLUSS
FILLER CAP
ETL:
0506 7612

BOUCHON DE REMPL

TAPON LLENADO

Baugruppe
construction group
groupe de construction
grupo de construcion

10

BEFESTIGUNGSTEILE
FASTENINGS
ETL:
0507 9021

PIECES DE FIXAT.

PIEZAS DE SUJECION

NOCKENWELLE
CAMSHAFT
ETL:
0507 9174

ARBRE A CAMES

ARBOL DE LEVAS

NOCKENWELL.ANTRIEB
CAMSHAFT DRIVE
ETL:
0507 9185

MECANISME COMMANDE

ACCION.ARBOL LEVAS



Baugruppenverzeichnis (BG)
Index of ETL (BG)
Index de ETL (BG)
Indice de ETL (BG)

Datum/Date/Fecha 27.10.2004

Seite/Page/Página: 2 / 5

SCHUTZHAUBE
PROTECTION HOOD
CAPOT PROTECTEUR
CAPERUZA PROTECT.

ETL:
0507 9197

Baugruppe
construction group
groupe de construction
grupo de construcion

11

STEUERUNGSTEILE
VALVE DRIVE
PIECES DISTRIBUT
PIEZAS DISTRIBUC.

ETL:
0506 7617

KIPPEBELBOCK
ROCKER ARM BRACKET
SUPPORT DE L'AXE
CABALLETE BALANCIN

ETL:
0505 1930

Baugruppe
construction group
groupe de construction
grupo de construcion

14

SCHMIEROELPUMPE
LUBRICAT. OIL PUMP
POMPE
BOMBA ACEITE LUBR.

ETL:
0507 4219

Baugruppe
construction group
groupe de construction
grupo de construcion

15

SCHMIEROELFILTER
LUBRIC. OIL FILTER
FILTRE A HUILE
FILTRO ACEITE LUBR.

ETL:
0506 4400

OELKUEHLER
OIL COOLER
REFROIDISSEUR
ENFRIADOR D.ACEITE

ETL:
0507 4378

FILTERKONSOLE
BRACKET
CONSOLE DE FILTRE
CONSOLA DEL FILTRO

ETL:
0507 7896

STEUERLEITUNG
PILOT LINE
CONDUIT.D.PILOTAGE
TUBERIA DE MANDO

ETL:
0507 7917

Baugruppe
construction group
groupe de construction
grupo de construcion

16

DRUCKBEGR.VENTIL
PRESS.RELIEF VALVE
LIMITEUR DE PRESS.
VALV.LIMIT.PRESION

ETL:
0506 7624

OELSAUGLEITUNG
OIL SUCTION LINE
COND.ASPIR.D'HUILE
TUBER.ASPIR.ACEITE

ETL:
0506 7625

OELRUECKLAUFROHR
OIL RETURN PIPE
TUYAU RETOUR
TUBO RETORNO ACEIT

ETL:
0506 8258

SCHMIEROELLEITUNG
LUBRICAT. OIL LINE
CONDUITE A HUILE
TUBER.ACEITE LUBR.

ETL:
0506 9035

Baugruppe
construction group
groupe de construction
grupo de construcion

17

VERSCHLUSSSCHRAUBE
SCREW PLUG
BOUCHON FILETE
TAPON ROSCADO

ETL:
0506 7639

BEFESTIGUNGSTEILE
FASTENINGS
PIECES DE FIXAT.
PIEZAS DE SUJECION

ETL:
0507 9205

EINSPRITZPUMPE
FUEL INJECT. PUMP
POMPE D'INJECTION
BOMBA DE INYECCION

ETL:
0507 9214

Baugruppe
construction group
groupe de construction
grupo de construcion

19

EINSPRITZVENTIL
FUEL INJECTOR
PORTE-INJECTEUR
INJECTOR

ETL:
0507 9013

Baugruppe
construction group
groupe de construction
grupo de construcion

20

FILTERPATRONE
FILTER CARTRIDGE
CARTOUCHE FILTRANT
CARTUCHO FILTRO

ETL:
0506 7542

KONSOLE
BRACKET
CONSOLE
CONSOLA

ETL:
0506 8026

KR.STOFF-FOERD.PPE
FUEL SUPPLY PUMP
POMPE ALIMENT.COMB
BOMBA ALIMENT.COMB

ETL:
0507 9014



Baugruppe
construction group
groupe de construction
grupo de construcion

21

KRAFTSTOFFLEITUNG FUEL LINE CONDUITE COMBUST. TUBERIA COMBUSTIB.	ETL: 0507 9171
KRAFTSTOFFLEITUNG FUEL LINE CONDUITE COMBUST. TUBERIA COMBUSTIB.	ETL: 0507 9002
KRAFTSTOFFLEITUNG FUEL LINE CONDUITE COMBUST. TUBERIA COMBUSTIB.	ETL: 0507 9003
EINSPRITZLEITUNG HIGH PRESSURE PIPE TUYAUTERIE TUBERIA INYECCION	ETL: 0507 9015
KRAFTSTOFFLEITUNG FUEL LINE CONDUITE COMBUST. TUBERIA COMBUSTIB.	ETL: 0507 9172
KRAFTSTOFFFILTER FUEL FILTER FILTRE A COMBUST. FILTRO COMBUSTIBLE	ETL: 0507 9170

Baugruppe
construction group
groupe de construction
grupo de construcion

22

VERSCHLUSSTEILE BLANKING PARTS OBTURATEURS PIEZAS DE CIERRE	ETL: 0506 3419
VERSCHLUSSTEILE BLANKING PARTS OBTURATEURS PIEZAS DE CIERRE	ETL: 0506 8283
UEBERGANGSLEITUNG TRANSFER PIPE EMBOUT TUBERIA TRASPASO	ETL: 0506 9171
LADELFTLEITUNG CHARGE AIR PIPE TUBULURE D'AIR TUB. A/SOBRREALIMENT	ETL: 0507 9206

Baugruppe
construction group
groupe de construction
grupo de construcion

26

GLUEHKERZE GLOW PLUG BOUGIE D.PRECHAUFF BUJIA INCANDESC.	ETL: 0506 3365
---	--------------------------

Baugruppe
construction group
groupe de construction
grupo de construcion

27

FEDERKAPSEL TORQUE CONTR.SPRG. CAPSULE CAPSULA RESORTE	ETL: 0507 9118
REGELSTANGE CONTROL ROD TIGE DE REGLAGE BARRA D.REGULACION	ETL: 0506 7616
ANSCHLAG LIMIT STOP BUTEE TOPE	ETL: 0507 7923
VORD.DECKEL/REGLER FRONT COVER/GOVERN COUVERCLE_AV/REGUL TAPA DELANT/REGULA	ETL: 0507 9062

Baugruppe
construction group
groupe de construction
grupo de construcion

33

VERSCHLUSSTEILE BLANKING PARTS OBTURATEURS PIEZAS DE CIERRE	ETL: 0507 4236
--	--------------------------

Baugruppe
construction group
groupe de construction
grupo de construcion

39

SCHMALKEILRIEMEN NARROW V-BELT COURR TRAP ETROITE CORR. TRAPEC. ESTREC	ETL: 0506 3354
DICHTPROFIL SEALING SECTION PROFIL D'ETANCH PERFIL HERMETIZAN.	ETL: 0506 7679
GEBLAESEMANTEL BLOWER JACKET ENVELOPPE SOUFFLTE ENVOLVENT.SOPLANTE	ETL: 0506 7681
KUEHLGEBLAESE COOLING FAN SOUFFLANTE REFROID VENTILADOR	ETL: 0507 9237



Baugruppenverzeichnis (BG)
Index of ETL (BG)
Index de ETL (BG)
Indice de ETL (BG)

Datum/Date/Fecha: 27.10.2004

Seite/Page/Página: 4 / 5

SPANNROLLE
TENSIONING PULLEY
POULIE DE TENSION
POLEA TENSORA

ETL:
0505 1119

Baugruppe
construction group
groupe de construction
grupo de construcion **40**

HAUBE
COOLING AIRDUCT
TUYAUTERIE D'AIR
GUIA AIRE REFRIGE.

ETL:
0507 9156

PROFILGUMMI
SECTIONAL RUBBER
PROFILE CAOUTCHOUC
PERFIL DE GOMA

ETL:
0506 8013

LUFTFUEHRUNG
AIR GUIDANCE
CONDUITE D'AIR
CONDUCTO DE AIRE

ETL:
0506 8215

BEFESTIGUNGSTEILE
FASTENINGS
PIECES DE FIXAT.
PIEZAS DE SUJECION

ETL:
0507 4284

STANDBLECH
AIR DUCT REAR WALL
TOLE VERTICALE
CHAPA VERTICAL

ETL:
0507 9125

Baugruppe
construction group
groupe de construction
grupo de construcion **41**

ABGASSAMMELLEITUNG
EXHAUST MANIFOLD
COLLECT.D'ECHAPPEM
TUB.COLECT.ESCAPE

ETL:
0506 9183

GEGENFLANSCH
COMPANION FLANGE
CONTRE-BRIDE
CONTRABRIDA

ETL:
0506 3108

Baugruppe
construction group
groupe de construction
grupo de construcion **43**

ABGASTURBOLADER
TURBOCHARGER
TURBOCOMPRESSEUR
TURBO

ETL:
0507 9011

Baugruppe
construction group
groupe de construction
grupo de construcion **44**

STARTER
STARTER
DEMARREUR
ARRANCADOR

ETL:
0507 4199

GENERATOR
GENERATOR
GENERATRICE
GENERADOR

ETL:
0507 9007

Baugruppe
construction group
groupe de construction
grupo de construcion **48**

KABELBAUM
CABLE HARNESS
FAISCEAU DE CABLES
HAZ DE CABLES

ETL:
0507 9133

ELEKTR. LEITUNG
ELECTRIC LINE
CONDUIT.ELECTRIQUE
CABLE ELECTRICO

ETL:
0506 7715

BEFESTIGUNGSTEILE
FASTENINGS
PIECES DE FIXAT.
PIEZAS DE SUJECION

ETL:
0506 8111

STECKERGEHAEUSE
PLUG HOUSING
LOGEMENT DE FICHE
CAJA DE ENCHUFE

ETL:
0506 8115

BEFESTIGUNGSTEILE
FASTENINGS
PIECES DE FIXAT.
PIEZAS DE SUJECION

ETL:
0506 8273

Baugruppe
construction group
groupe de construction
grupo de construcion **51**

DRUCKGEBER
PRESSURE SENSOR
TRANSMETTEUR DE PR
TRANSMISOR PRESION

ETL:
0506 8119

TEMPERATURGEBER
TEMPER. TRANSMITTER
SONDE THERMIQUE
SENSOR TEMPERATUR

ETL:
0506 9029

Baugruppe
construction group
groupe de construction
grupo de construcion **52**

ABDECKBLECH
COVER PLATE
TOLE RECOUVREMENT
CHAPA DE CUBIERTA

ETL:
0505 1756



ZWISCHENGEHAEUSE
ADAPTER HOUSING
CARTER INTERMED.
CAJA INTERMEDIA

ETL:
0506 9152

Baugruppe
construction group
groupe de construction
grupo de construcion

56

MOTORABSTELLUNG
SHUTDOWN DEVICE
ARRET DU MOTEUR
PARADA DEL MOTOR

ETL:
0507 9085

BEFESTIGUNGSTEILE
FASTENINGS
PIECES DE FIXAT.
PIEZAS DE SUJECION

ETL:
0507 9139

Baugruppe
construction group
groupe de construction
grupo de construcion

57

KEILRIEMENSCHUTZ
V-BELT GUARD
PROT COURR TRAPEZ
PROTECCION

ETL:
0507 4297

Baugruppe
construction group
groupe de construction
grupo de construcion

90

ZUS.-DICHTUNGSSATZ
SUPPLEM.GASKET SET
JEU DE JOINTS AUX.
JUEGO JUNTAS COMPL.

ETL:
0507 4086

DICHTUNGSSATZ
GASKET SET
JEU DE JOINTS
JUEGO DE JUNTAS

ETL:
0507 7823

Baugruppe
construction group
groupe de construction
grupo de construcion

98

DRUCKFEDER
COMPRESSION SPRING
RESSORT DE PRESS.
RESORTE DE PRESION

ETL:
0417 0886

SICHERUNGSSCHRAUBE
LOCKING SCREW
VIS D'ARRET
TORNILLO FIJACION

ETL:
0211 2403

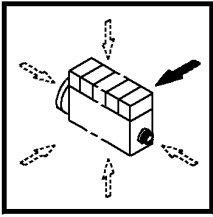

000 ©

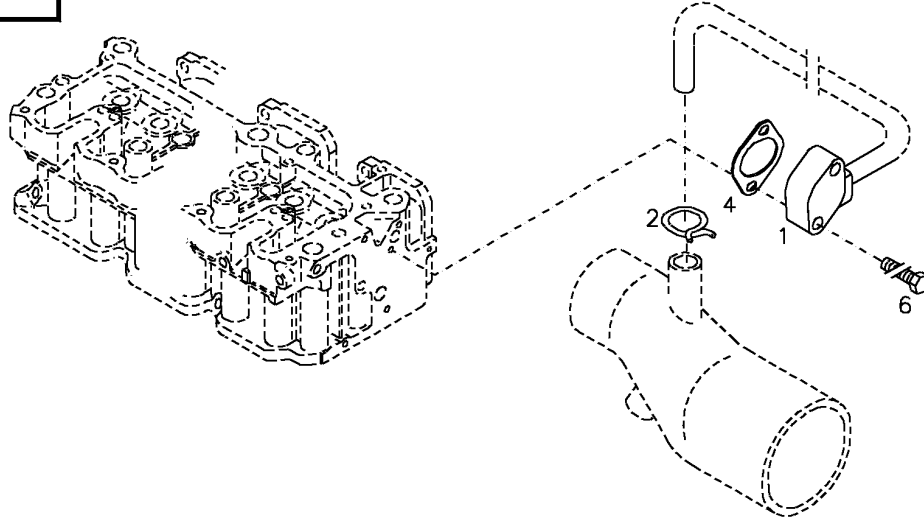

Pos	Teile -Nr.	Stk	Deutsch	English	Francais	Espagnol	Nummer / Bemerkung / Note
001	0428 0347	001	ENTLUEFTUNGSROHR	BREATHER PIPE	TUBE DE DESAERAGE	TUBO DESAIREACION	
002	0117 8468	001	SCHLAUCHKLEMME	HOSE CLIP	COLLIER A FLEXIBLE	PINZA DE MANGUERA	
004	0427 1080	001	DICHTUNG	GASKET	GARNITURE/JOINT	JUNTA	
006	0118 1882	002	SECHSKANTSCHRAUBE	HEXAGON BOLT	VIS TETE HEXAGONAL	TORN.DE CABE.EXAG.	



OELMESSSTAB
DIPSTICK
JAUGE D.PROFONDEUR
SONDA DE ACEITE

01 - 0507 7818

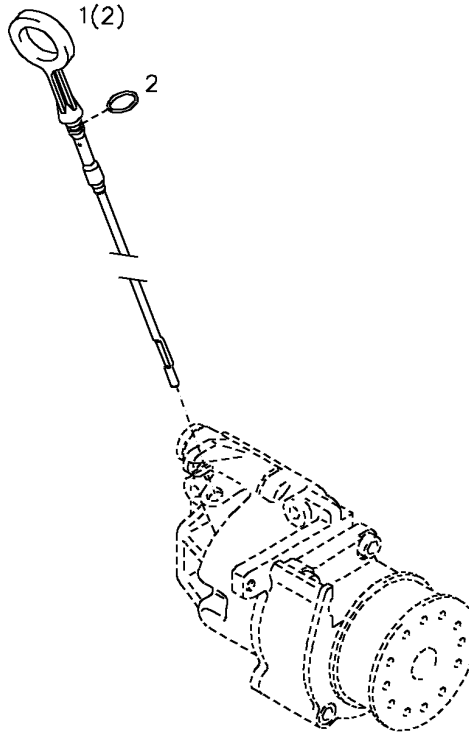
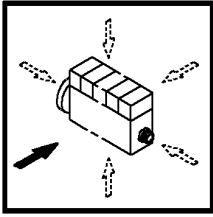

000 ©

Pos	Teile -Nr.	Stk	Deutsch	English	Francais	Espagnol	Nummer / Bemerkung / Note
001	0427 2815	001	OELMESSSTAB	DIPSTICK	JAUGE D.PROFONDEUR	SONDA DE ACEITE	MIT POS... WITH ITEM... CON POS AVEC POSTE... (2)
002	0118 0693	001	RUNDDICHTRING	O-SEAL	ANNEAU TORIQUE	JUNTA TORNICA	

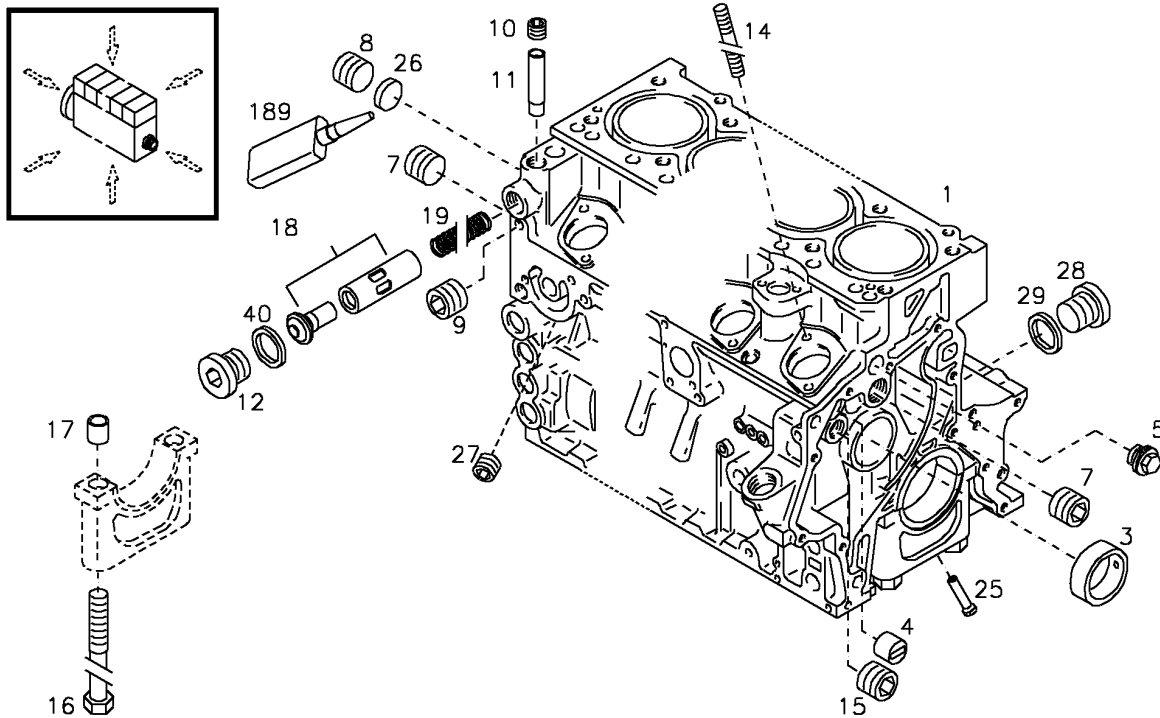

Pos	Teile -Nr.	Stk	Deutsch	English	Francais	Espagnol	Nummer / Bemerkung / Note
001	0428 1941	001	ZYL. KURBELGEHAEUSE	ENGINE BLOCK	BLOC-MOTEUR	BLOQUE D.CILINDROS	Mit Pos...(2-19)
003	0417 8154	003	LAGERBUCHSE	WRAPPED BEAR. BUSH	BAGUE ROULEE	CASQUILLO COJINETE	
004	0210 8055	002	FUEHRUNGSHUELSE	GUIDE SLEEVE	DOUILLE DE GUIDAGE	CASQUILLO GUIA	
005	0417 8741	001	VERSCHLUSSSCHRAUB	SCREW PLUG	BOUCHON FILETE	TAPON ROSCADO	
007	0427 1453	002	VERSCHLUSSSCHRAUB	SCREW PLUG	BOUCHON FILETE	TAPON ROSCADO	
008	0118 0891	001	VERSCHLUSSSCHRAUB	SCREW PLUG	BOUCHON FILETE	TAPON ROSCADO	
009	0118 0889	001	VERSCHLUSSSCHRAUB	SCREW PLUG	BOUCHON FILETE	TAPON ROSCADO	
010	0118 0887	001	VERSCHLUSSSCHRAUB	SCREW PLUG	BOUCHON FILETE	TAPON ROSCADO	
011	0417 8218	001	ROHR	TUBE	TUYAU	TUBO	
012	0427 0312	001	VERSCHLUSSSCHRAUB	SCREW PLUG	BOUCHON FILETE TETE	TAPON ROSCADO	Mit Pos...(40)
014	0118 2090	008	STIFTSCHRAUBE	STUD	GOUJON	ESPARRAGO	
015	0118 0888	001	VERSCHLUSSSCHRAUB	SCREW PLUG	BOUCHON FILETE	TAPON ROSCADO	
016	0210 8134	010	SECHSKANTSCHRAUBE	HEXAGON BOLT	VIS TETE HEXAGONAL	TORN.DE CABE.EXAG.	
017	0336 2279	010	BUCHSE	BUSH	DOUILLE	CASQUILLO	
018	0417 9928	001	THERMOSTAT	THERMOSTAT	THERMOSTAT	TERMOSTATO	Mit Pos...(19)
019	0417 8238	001	DRUCKFEDER	COMPRESSION SPRING	RESSORT DE PRESS.	RESORTE DE PRESION	
025	0417 8452	008	KOLBENKUEHLDUESE	PISTON COOL.NOZZLE	GICLEUR D.REFROID.	TOBERA DE REFRIG.	
026	0114 8153	001	VERSCHLUSSDECKEL	COVER	COUVERCLE OBTURAT.	TAPA DE CIERRE	
027	0118 0886	001	VERSCHLUSSSCHRAUB	SCREW PLUG	BOUCHON FILETE	TAPON ROSCADO	
028	0111 0422	001	VERSCHLUSSSCHRAUB	SCREW PLUG	BOUCHON FILETE	TAPON ROSCADO	
029	0111 8673	001	DICHTRING	SEALINGRING	BAGUE D'ETANCHEITE	JUNTA ANULAR	
040	0118 0446	001	RUNDDICHTRING	O-SEAL	ANNEAU TORIQUE	JUNTA TORNICA	
189	0101 6125	010	SICHERUNGSMITTEL	SAFETY/LOCK.AGENT	RESINE-FREIN	MEDIO AFIANZADOR	

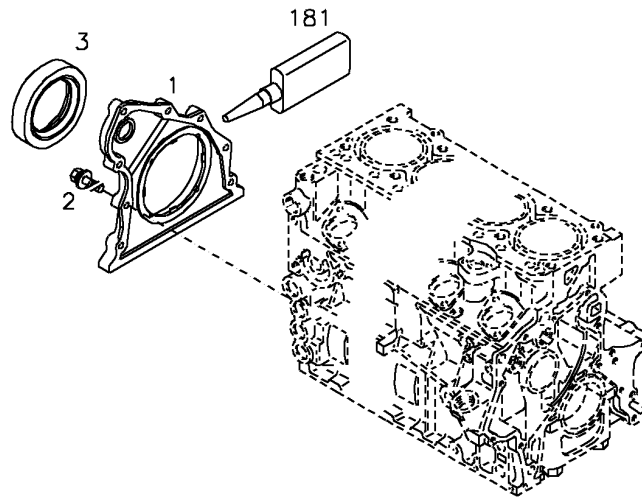
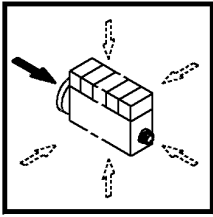

Pos	Teile -Nr.	Stk	Deutsch	English	Francais	Espagnol	Nummer / Bemerkung / Note
001	0428 6436	001	HINTERER DECKEL	REAR END COVER	COUVERCLE ARRIERE	TAPA TRASERA	
002	0117 6558	008	SECHSKANTSCHRAUBE	HEXAGON BOLT	VIS TETE HEXAGONAL	TORN.DE CABE.EXAG.	
003	0417 5433	001	RAD.WELL.DICHTRING	ROT.SHAFT LIP SEAL	JOINT A LEVRE	ANILLO.D.JUNTA RAD	
181	0101 6122	001	DICHTUNGSMASSE	PACKING COMPOUND	HERMETIC	PASTA HERMETIZANTE	

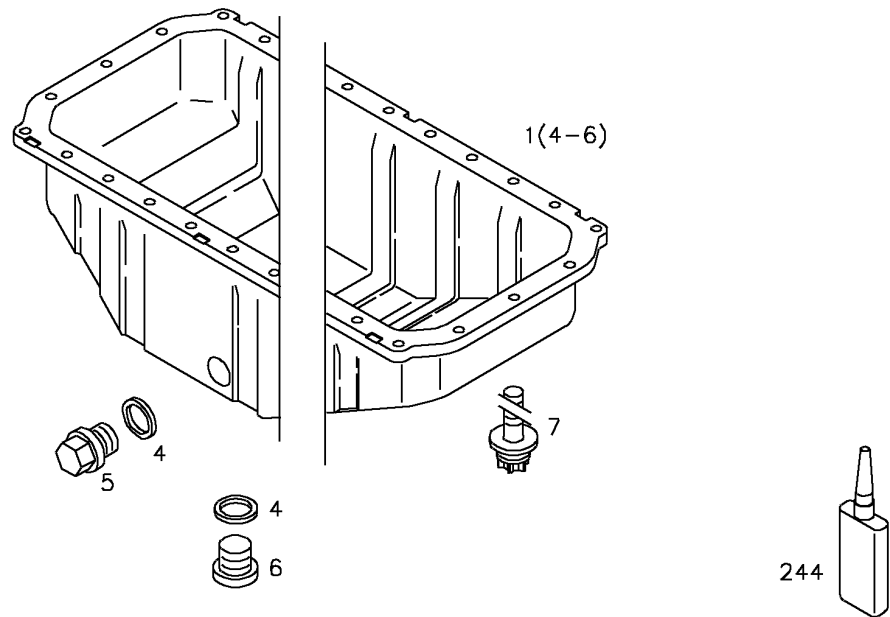

Pos	Teile -Nr.	Stk	Deutsch	English	Français	Espagnol	Nummer / Bemerkung / Note
001	0292 9924	001	OELWANNE	OIL PAN	CARTER A HUILE	CARTER DE ACEITE	MIT POS.... WITH ITEM.... CON POS. AVEC POSTE.... (4-6)
004	0111 8718	002	DICHTRING	SEALINGRING	BAGUE D'ETANCHEITE	JUNTA ANULAR	
005	0112 3690	001	VERSCHLUSSSCHRAUB	SCREW PLUG	BOUCHON FILETE	TAPON ROSCADO	
006	0115 1441	001	VERSCHLUSSSCHRAUB	SCREW PLUG	BOUCHON FILETE	TAPON ROSCADO	
007	0118 1420	026	TORX-SCHRAUBE	TORX-HEAD BOLT	VIS A TETE TORX	TORNILLO TEST.TORX	
244	0101 6102	001	DICHTUNGSMASSE	PACKING COMPOUND	HERMETIC	PASTA HERMETIZANTE	

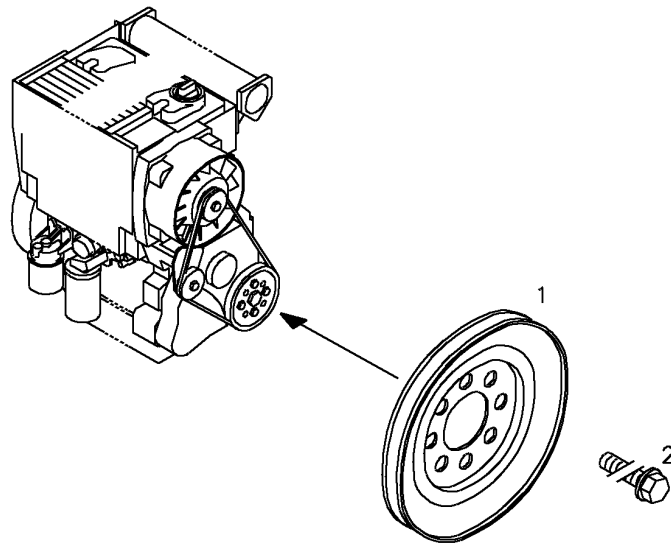

Pos	Teile -Nr.	Stk	Deutsch	English	Français	Espagnol	Nummer / Bemerkung / Note
001	0417 3227	001	KEILRIEMENSCHLEIBE	V-GROOVED PULLEY	POULIE A GORGE	POLEA TRAPECIAL	
002	0118 1389	008	SECHSKANTSCHRAUBE	HEXAGON BOLT	VIS TETE HEXAGONAL	TORN.DE CABE.EXAG.	

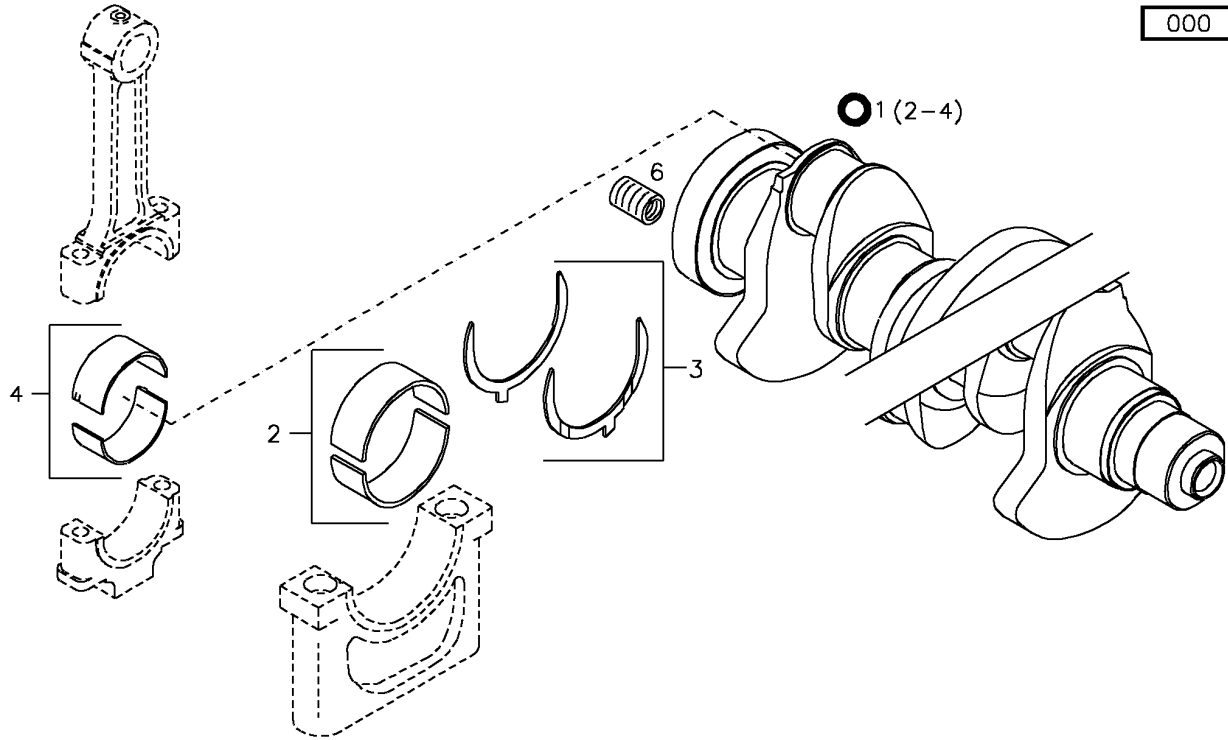

Pos	Teile -Nr.	Stk	Deutsch	English	Francais	Espagnol	Nummer / Bemerkung / Note
001	0427 0236	001	KURBELWELLE	CRANKSHAFT	VILEBREQUIN	CIGUENAL	NEUTEIL, AUSTAUSCHTEIL SIEHE POS.(A) KOMPL. MIT POS. SPAREPART (NEW), REMANUFACTURED PART SEE ITEM (A) COMPL. WITH ITEM COMPONENTE NUEVO, COMPONENTE REACONDICIONADO VER POS. (A) COMPL. CON POS. NOUVELLE PIECE, PIECE DE RECHANGE VOIR REP. (A) COMPLET AVEC REP. (2-4) (A) 950
002	0427 0238	005	KURBELWELLENLAGER	MAIN BEARING	PALIER DE LIGNE	COJINETE D.BANCADA	NORMAL (A) MM RD, UNTERMASSTUFE SIEHE POS.(B) STANDARD (A)MM RD, FOR UNDERSIZE SEE ITEM (B) DIAM. NORMAL (A)MM, MEDIDA DE DESGASTE VER POS. (B) NORMAL (A) MM ROND, COTE EN SOUS-DIMENSION, VOIR POSTE (B A 70,00 B 951.952
003	0292 8961	001	ANLAUFSCHLEIBE	THRUST WASHER	RONDELLE DE BUTEE	ARANDELA TOPE	NORMAL (A)MM, UEBERMASSTUFE SIEHE POS. (B) STANDARD (A)MM, FOR OVERSIZE SEE ITEM (B) NORMAL (A)MM, SOBREMEDIDA VE POS. (B) NORMAL (A)MM, COTE EN

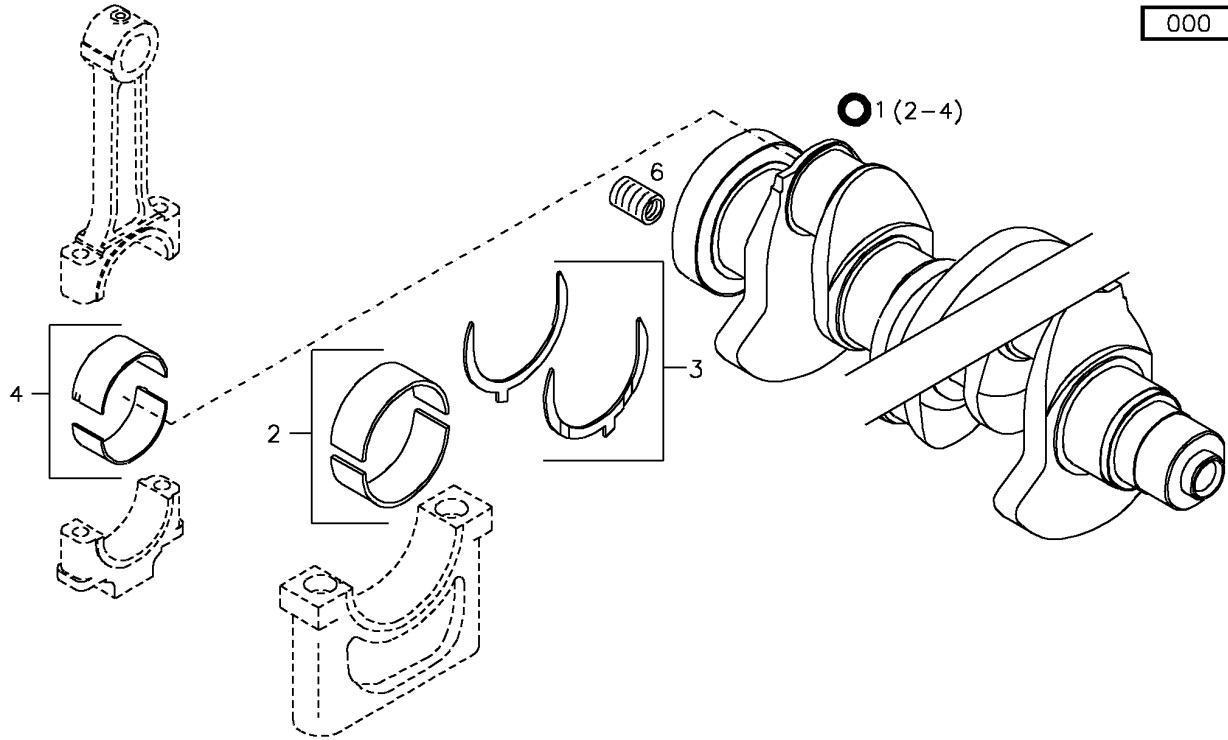

Pos	Teile -Nr.	Stk	Deutsch	English	Francais	Espagnol	Nummer / Bemerkung / Note
003	0292 8961	001	ANLAUFSCHIEBE	THRUST WASHER	RONDELLE DE BUTEE	ARANDELA TOPE	SURDIMENSION VOIR POSTE (B) (A) 2,4 (B) 953
004	0427 0255	004	PLEUELLAGER	BIG END BEARING	PALIER TETE BIELLE	COJINETE CAB.BIELA	NORMAL (A) MM RD, UNTERMASSTUFE SIEHE POS.(B) STANDARD (A)MM RD, FOR UNDERSIZE SEE ITEM (B) DIAM. NORMAL (A)MM, MEDIDA DE DESGASTE VER POS. (B) NORMAL (A) MM ROND, COTE EN SOUS-DIMENSION, VOIR POSTE (B) (A) 55,0 (B) 954, 955
006	0621 8864	001	GEWINDEEINSATZ	THREADED INSERT	GARNITURE FILETEE	HELICOIL	AUSTAUSCHTEIL, NEUTEIL SIEHE POS. (A) KOMPL. MIT POS. REMANUFACTURED PART, NEW PART SEE ITEM (A) COMPL. WITH ITEM COMPONENTE REACONDICIONADO, COMPONENTE NUEVO VER POS.(A) COMPL. CON POS. PIECE DE RECHANGE, NOUVELLE PIECE VOIR REP (A) COMPLET AVEC REP. A 1 B 951,953,954
950	0292 9801	001	AT-KURBELWELLE	EXCH. CRANKSHAFT	VILEBREQUIN ECH	CIGUENAL REA	
951	0427 0242	005	KURBELWELLENLAGER	MAIN BEARING	PALIER DE LIGNE	COJINETE D.BANCADA	1. UNTERMASSTUFE 1ST UNDERSIZE 1A MEDIDA DE DESGASTE 1ERE COTE EN SOUS-DIMENSION 69,75 MM RD
952	0427 0247	005	KURBELWELLENLAGER	MAIN BEARING	PALIER DE LIGNE	COJINETE D.BANCADA	2. UNTERMASSTUFE

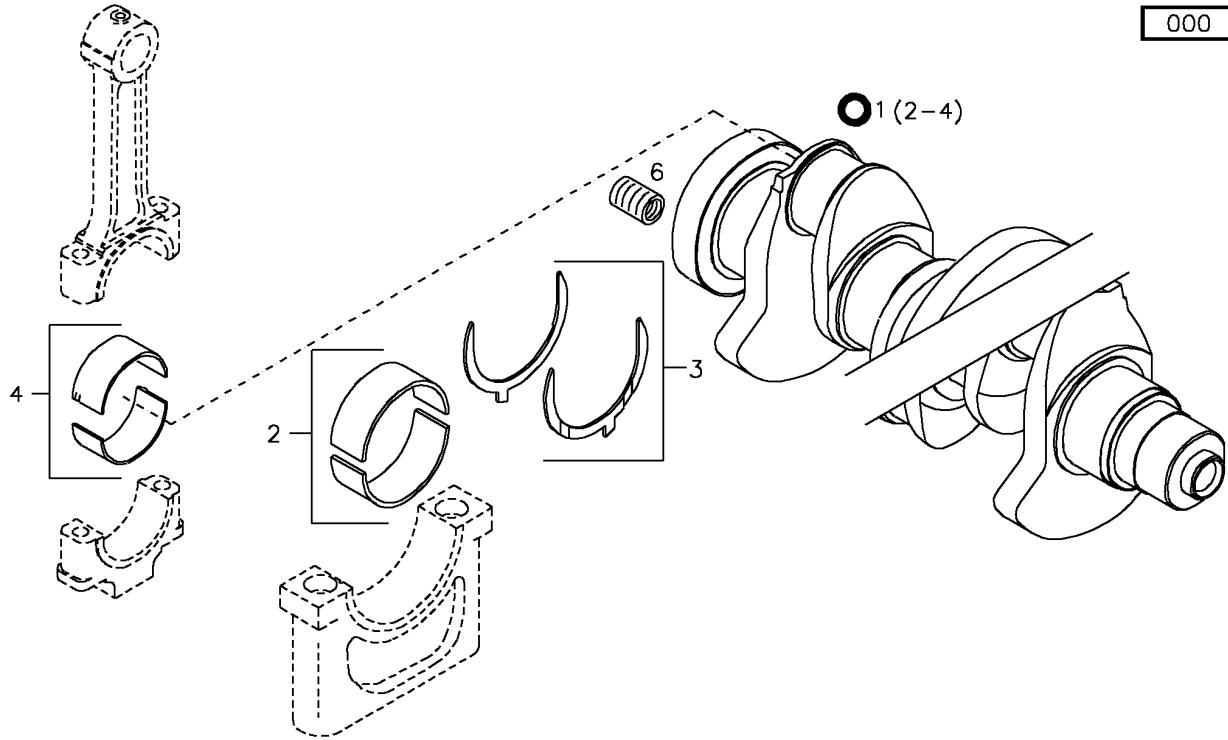

Pos	Teile -Nr.	Stk	Deutsch	English	Francais	Espagnol	Nummer / Bemerkung / Note
952	0427 0247	005	KURBELWELLENLAGER	MAIN BEARING	PALIER DE LIGNE	COJINETE D BANCADA	2ND UNDERSIZE 2A MEDIDA DE DESGASTE 2EME COTE EN SOUS-DIMENSION 69.50 MM RD
953	0292 8962	001	ANLAUFSCHIEBE	THRUST WASHER	RONDELLE DE BUTEE	ARANDELA TOPE	1. UEBERSTUFE 1ST OVERSIZE 1A SOBREMEDIDA 1ERE COTE EN SURDIMENSION 2.6 MM
954	0427 0259	004	PLEUELLAGER	BIG END BEARING	PALIER TETE BIELLE	COJINETE CAB.BIELA	1. UNTERSTUFE 1ST UNDERSIZE 1A MEDIDA DE DESGASTE 1ERE COTE EN SOUS-DIMENSION 54.75 MM RD
955	0427 0263	004	PLEUELLAGER	BIG END BEARING	PALIER TETE BIELLE	COJINETE CAB.BIELA	2. UNTERSTUFE 2ND UNDERSIZE 2A MEDIDA DE DESGASTE 2EME COTE EN SOUS-DIMENSION 54.50 MM RD

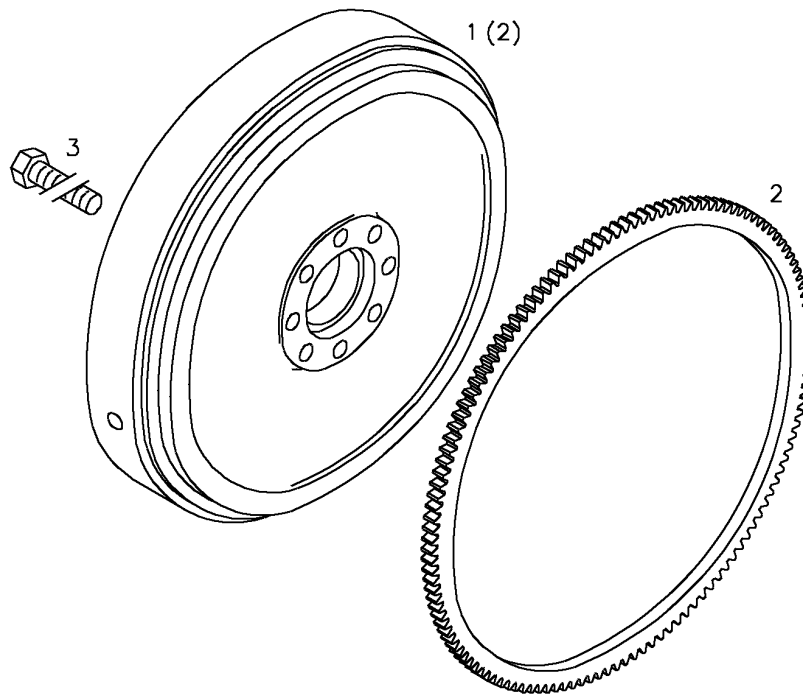
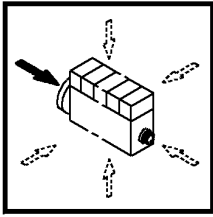

000 ©

Pos	Teile -Nr.	Stk	Deutsch	English	Francais	Espagnol	Nummer / Bemerkung / Note
001	0427 2425	001	SCHWUNGRAD	FLYWHEEL	VOLANT	VOLANTE	MIT POS.... WITH ITEM.... CON POS AVEC POSTE.... (2)
002	0427 2421	001	ZAHNKRANZ	GEAR RIM	COURONNE DENTEE	CORONA DENTADA	
003	0210 9988	008	SCHRAUBE	SCREW/BOLT	VIS/BOULON	TORNILLO	

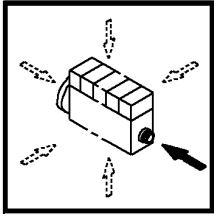

000 ©

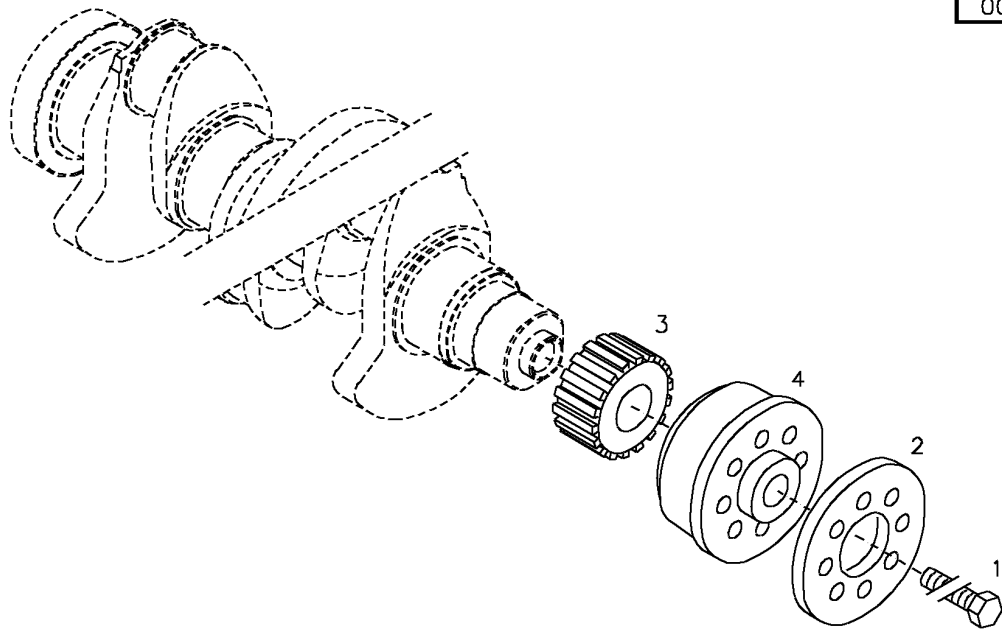

Pos	Teile -Nr.	Stk	Deutsch	English	Francais	Espagnol	Nummer / Bemerkung / Note
001	0427 2546	001	SECHSKANTSCHRAUBE	HEXAGON BOLT	VIS TETE HEXAGONAL	TORN.DE CABE.EXAG.	
002	0428 0136	001	SCHLEUDERSCHEIBE	LUBE DEFLECTOR	DEFLECT.LUBRIF.	PLATO CENTRIFUGO.	
003	0417 3550	001	ZAHNRIEMENRAD	SYNCHR.BELT PULLEY	POULIE SYNCHRONE	RUED.CORREA DENTA	
004	0428 0116	001	ABTRIEBSFLANSCH	OUTPUT FLANGE	BRIDE MENE	BRIDA ACCIONAMIEN.	

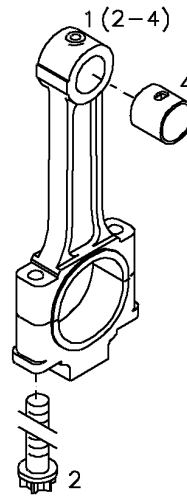
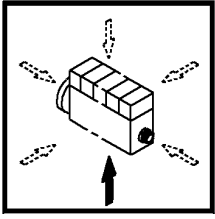

Pos	Teile -Nr.	Stk	Deutsch	English	Francais	Espagnol	Nummer / Bemerkung / Note
001	0427 2081	001	PLEUELSTANGE	CONNECTING ROD	BIELLE	BIELA	MIT POS.... WITH ITEM.... CON POS. AVEC POSTE.... (2-4)
002	0428 0016	002	PLEUELSCHRAUBE	BIG END BOLT	BOULON	TORNILLO DE BIELA	NORMAL (A) MM RD, UEBERMASSTUFE SIEHE POS. (B) STANDARD (A)MM RD, FOR OVERSIZE SEE ITEM (B) DIAM. NORMAL (A)MM, SOBREMEDIDA VER POS. (B) NORMAL (A)MM ROND, COTE EN SURDIMENSION VOIR POSTE (B) A 33.07-33.11 B 953
004	0417 0393	001	PLEUELBUCHSE	BIG END BUSH	BAGUE	CASQUILLO DE BIELA	
953	0417 0394	001	PLEUELBUCHSE	BIG END BUSH	BAGUE	CASQUILLO DE BIELA	UEBERMASSTUFE OVERSIZE SOBREMEDIDA COTE EN SURDIMENSION 33.32-33.36MM

000 ©

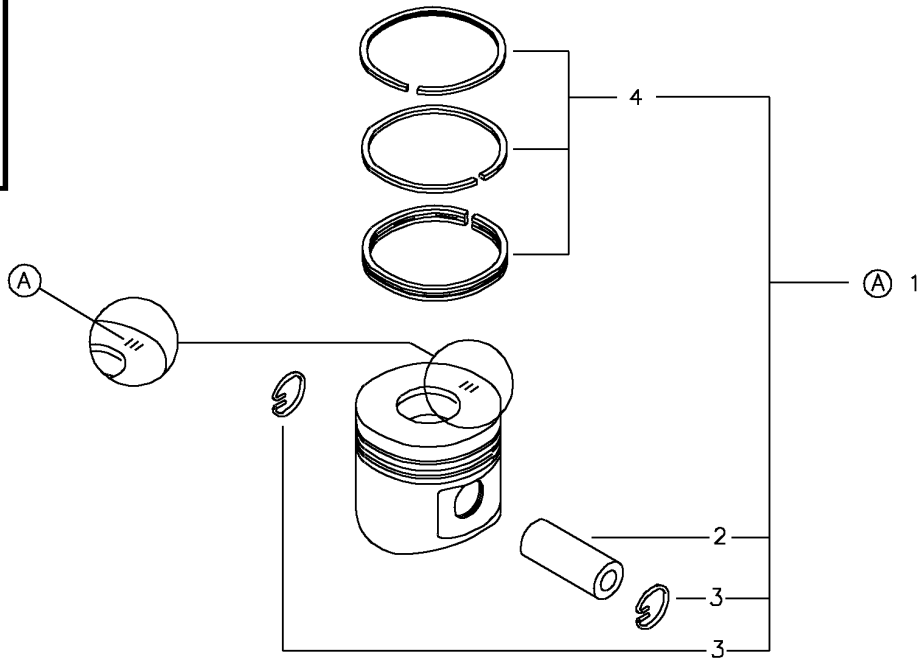
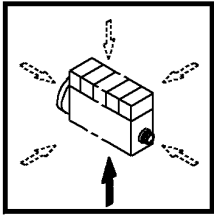

Pos	Teile -Nr.	Stk	Deutsch	English	Francais	Espagnol	Nummer / Bemerkung / Note
001	0428 1461	001	KOLBEN	PISTON	PISTON	PISTON	KOMPLETT COMPLETE COMPLETO COMPL. KOMPRESSIOnSHOEHENKLASSE "A"
002	0417 3414	001	KOLBENBOLZEN	PISTON PIN	AXE DE PISTON	BULON DEL PISTON	
003	0113 9875	002	SPRENGRING	SNAP RING	ANNEAU ELASTIQUE	ANILLO D. EXPANSION	
004	0428 0566	001	KOLBENRINGSATZ	SET OF PIST. RINGS	JEU DES SEGMENTS	JUEGO AROS PISTON	NORMAL STANDARD NORMAL STANDARD/NORMAL

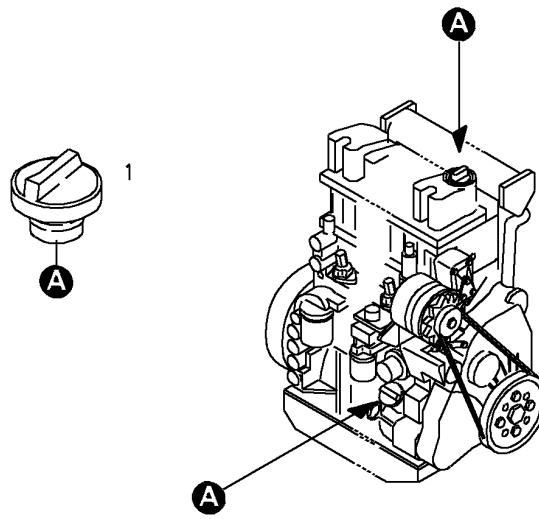

Pos	Teile -Nr.	Stk	Deutsch	English	Francais	Espagnol	Nummer / Bemerkung / Note
001	0417 9138	001	EINFUELLVERSCHLUSS	FILLER CAP	BOUCHON DE REMPL	TAPON LLENADO	

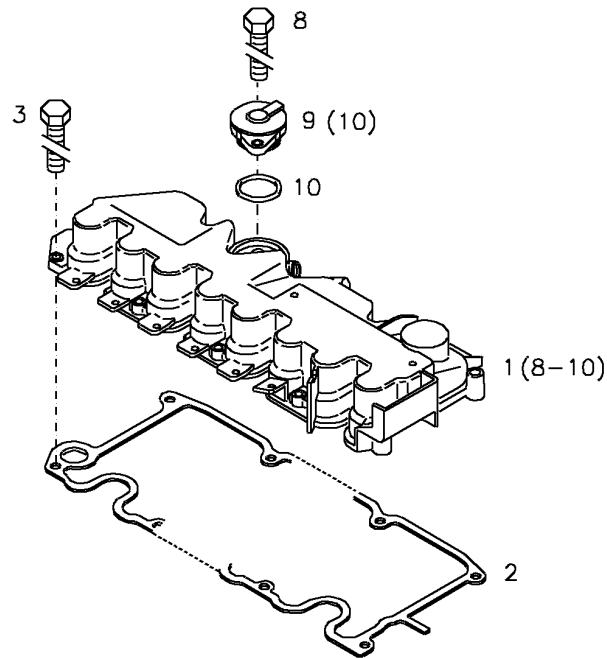

Pos	Teile -Nr.	Stk	Deutsch	English	Francais	Espagnol	Nummer / Bemerkung / Note
001	0427 1079	001	ZYL.-KOPF/-HAUBE	CYL. HEAD/HD. COVER	CULASSE/CAPOT CLS.	CULATA/CAPOT CUL.	MIT POS.... WITH ITEM.... CON POS. AVEC POSTE.... (8-10)
002	0427 1076	001	DICHTUNG	GASKET	GARNITURE/JOINT	JUNTA	
003	0114 8134	010	SECHSKANTSCHRAUBE	HEXAGON BOLT	VIS TETE HEXAGONAL	TORN.DE CABE.EXAG.	
008	0114 3874	001	SECHSKANTSCHRAUBE	HEXAGON BOLT	VIS TETE HEXAGONAL	TORN.DE CABE.EXAG.	
009	0427 1850	001	ENTLUEFTUNGSVENTIL	BREATHER VALVE	SOUP DEGAGEMENT D'AIR	VALVULA DESAIREAC.	MIT POS.... WITH ITEM.... CON POS. AVEC POSTE.... (10)
010	0118 0144	001	RUNDDICHRING	O-SEAL	ANNEAU TORIQUE	JUNTA TORNICA	

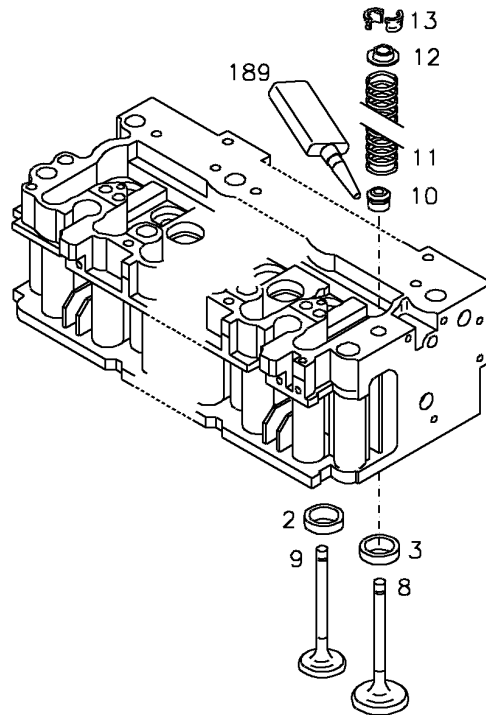
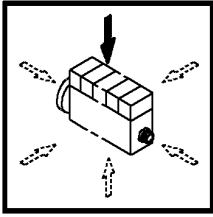

000 ©

Pos	Teile -Nr.	Stk	Deutsch	English	Francais	Espagnol	Nummer / Bemerkung / Note
001	0428 0264	001	ZYLINDERKOPF	CYLINDER HEAD	CULASSE	CULATA	NEUTEIL, AUSTAUSCHTEIL SIEHE POS.(A) KOMPL. MIT POS. SPAREPART (NEW), REMANUFACTURED PART SEE ITEM (A) COMPL. WITH ITEM COMPONENTE NUEVO, COMPONENTE REACONDICIONADO VER POS. (A) COMPL. CON POS. NOUVELLE PIECE, PIECE DE RECHANGE VOIR REP. (A) COMPLET AVEC REP. (2-3,8-13) (A) 952
002	0428 0047	004	VENTILSITZRING	VALVE SEAT INSERT	SIEGE RAPPORTE	ANILLO ASIEN VALV	AUSLASSVENTIL, NORMAL (A)MM RD UEBERMASSTUFE SIEHE POS. (B) EXHAUST VALVE, STANDARD(A)MM R FOR OVERSIZE SEE ITEM(B) VALVULA DE ESCAPE,DIAM. NORMAL. (A) MM, SOBREMEDIDA VER POS.(B) SOUPAPE D'ECHAPPEMENT, NORMAL (A) MM ROND,COTE EN SURDIMENSION VOIR POSTE (B) A) 37.07 B) 951
003	0428 0024	004	VENTILSITZRING	VALVE SEAT INSERT	SIEGE RAPPORTE	ANILLO ASIEN VALV	EINLASSVENTIL,NORMAL (A)MM RD UEBERMASSTUFE SIEHE POS. (B) INLET VALVE, STANDARD.(A)MM RD FOR OVERSIZE SEE ITEM (B) VALVULA DE ADMISSION, DIAM.

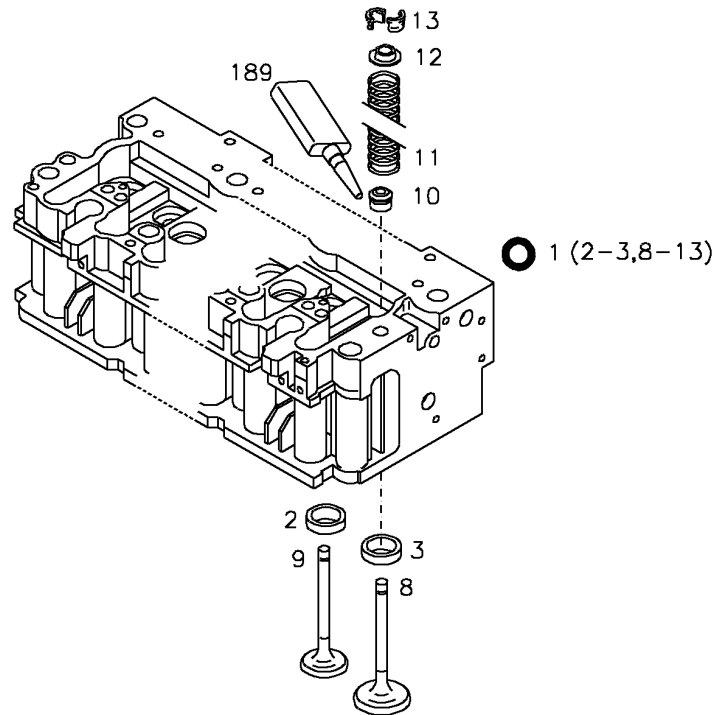
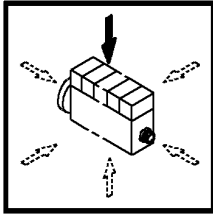

000 ©

Pos	Teile -Nr.	Stk	Deutsch	English	Français	Espagnol	Nummer / Bemerkung / Note
003	0428 0024	004	VENTILSITZRING	VALVE SEAT INSERT	SIEGE RAPPORTE	ANILLO ASIEN.VALV	NORMAL (A) MM, SOBREMEDIDA VER POS. (B) SOUPAPE D'ADMISSION,NORMAL (A).MM ROND,COTE EN SURDIMENSION VOIR POSTE (B) A) 42.67 B) 950
008	0428 0404	004	EINLASSVENTIL	INLET VALVE	SOUPAP.D'ADMISSION	VALVUL.DE ADMISION	
009	0428 0049	004	AUSLASSVENTIL	EXHAUST VALVE	SOUPAP.D'ECHAPPEM.	VALVULA DE ESCAPE	
010	0415 3728	008	VENTILSCHAFTDICHTG	VALVE STEM SEAL	JOINT TIGE SOUPE	JUNTA VAST.VALVULA	
011	0417 9633	008	DRUCKFEDER	COMPRESSION SPRING	RESSORT DE PRESS.	RESORTE DE PRESION	
012	0428 0025	008	FEDERTELLER	SPRING CAP	CUVETTE DE RESSORT	PLATO DE RESORTE	
013	0210 8102	016	VENTILKEGELSTUECK	VALVE COLLET	SEMI-CONE VALVULA	CONE ABRAZADOR	
189	0101 6125	001	SICHERUNGSMITTEL	SAFETY/LOCK.AGENT	RESINE-FREIN	MEDIO AFIANZADOR	
950	0427 2035	004	VENTILSITZRING	VALVE SEAT INSERT	SIEGE RAPPORTE	ANILLO ASIEN.VALV	EINLASSVENTIL, 1.UEBERMASS- STUFE INLET VALVE, 1ST OVERSIZE VALVULA DE ADMISION, 1A SOBREMEDIDA SOUPAPE D'ADMISSION, 1ERE COTE EN SURDIMENSION 42.87 MM
951	0210 8643	004	VENTILSITZRING	VALVE SEAT INSERT	SIEGE RAPPORTE	ANILLO ASIEN.VALV	AUSLASSVENTIL, 1.UEBERMASS- STUFE EXHAUST VALVE, 1ST OVERSIZE VALVULA DE ESCAPE, 1A SOBREMEDIDA SOUPAPE D'ECHAPPEMENT, 1ERE COTE EN SURDIMENSION 37.27 MM
952	0428 0280	001	ZYLINDERKOPF	CYLINDER HEAD	CULASSE	CULATA	AUSTAUSCHTEIL, NEUTEIL SIEHE POS. (A) REMANUFACTURED PART, NEW PART SEE ITEM (A)

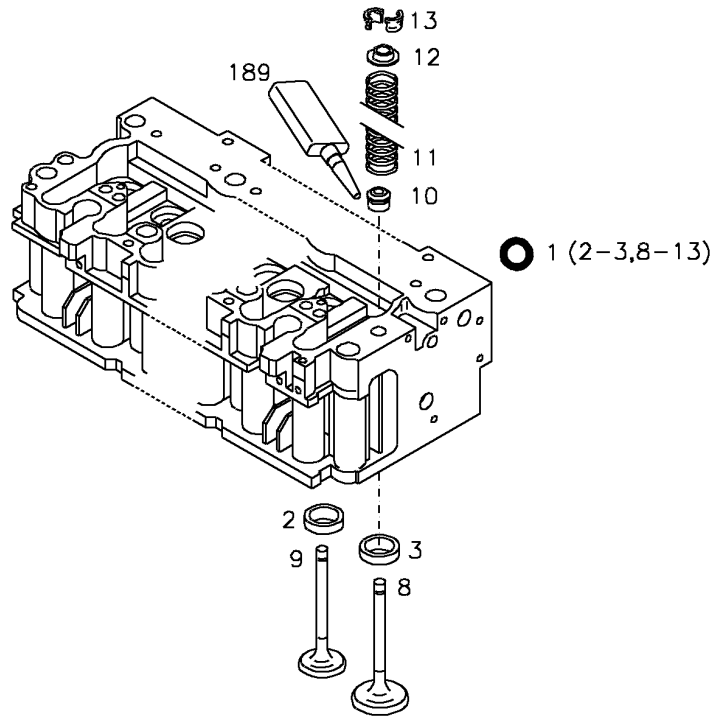
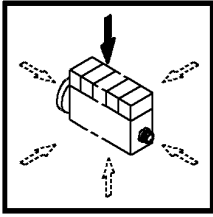

000 ©

Pos	Teile -Nr.	Stk	Deutsch	English	Francais	Espagnol	Nummer / Bemerkung / Note
952	0428 0280	001	ZYLINDERKOPF	CYLINDER HEAD	CULASSE	CULATA	COMPONENTE REACONDICIONADO, COMPONENTE NUEVO VER POS.(A) PIECE DE RECHANGE, NOUVELLE PIECE VOIR REP.(A) (A) POS. 1
953	0427 2011	008	VENTILFUEHRUNG	VALVE GUIDE	GUIDE DE SOUPE	GUIA DE VALVULA	

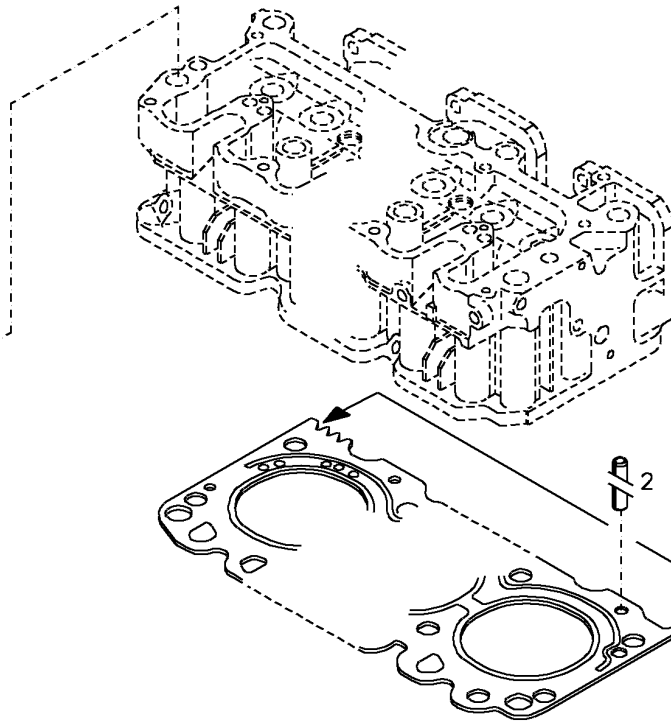
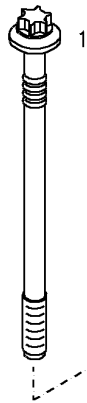
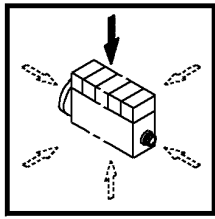

000 ©

Pos	Teile -Nr.	Stk	Deutsch	English	Français	Espagnol	Nummer / Bemerkung / Note
001	0427 0815	010	ZYL. KOPFSCHRAUBE	CYLINDER HEAD BOLT	GOUJON CULASSE	TORNILLO DE CULATA	VOM MESSERGEBNIS ABHAENGIG, DICHTUNGSDICKE -ANLIFERZUSTAND (A)= ...MM -EINBAUZUSTAND (B)= ...MM ANDERE DICKEN SIEHE POS. (C) GASKET THICKNESS DEPENDING ON MEASUREMENT RESULT -DELIVERY COND. (A)=...MM -INSTALLATION COND. (B)=...MM DIFF. THICKNESSES SEE ITEM (C) SEGUN EL RESULTADO DE LA ME- DICION, ESPESOR DE LA JUNTA -ESTADO LLEGADA (A)= ...MM -ESTADO MONTAJE (B)= ...MM PARA OTROS ESPESORES, VER POS. (C) DEPEND DU RESULTAT D MESURE, EPAISSEUR DE JOINT -ETAT DE LIVRAISON (A)= ...MM -ETAT DE MONTAGE (B)= ...MM AUTRES EPAISSEURS VOIR REP(C)
002	0417 8611	002	SPIRAL-SPANNSTIFT	SPIRAL PIN	GOUPILLE HELIC	PASADOR ESPIRAL	
003	0428 1060	001	ZYL. KOPFDICHTUNG	CYLIND. HEAD GASKET	JOINT DE CULASSE	JUNTA DE CULATA	VOM MESSERGEBNIS ABHAENGIG, DICHTUNGSDICKE -ANLIFERZUSTAND (A)= ...MM -EINBAUZUSTAND (B)= ...MM ANDERE DICKEN SIEHE POS. (C) GASKET THICKNESS DEPENDING ON MEASUREMENT RESULT -DELIVERY COND. (A)=...MM -INSTALLATION COND. (B)=...MM DIFF. THICKNESSES SEE ITEM (C) SEGUN EL RESULTADO DE LA ME-

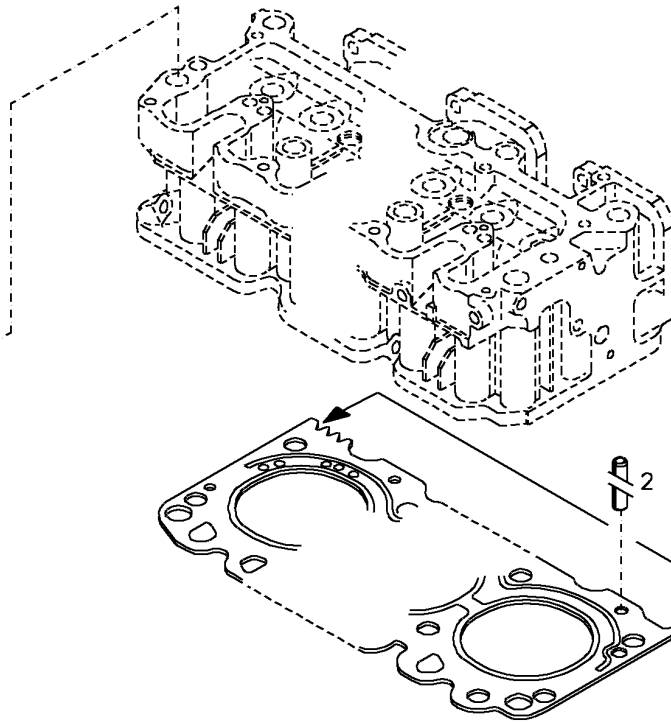
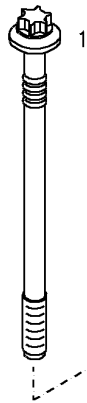
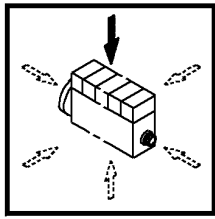

000 ©

Pos	Teile -Nr.	Stk	Deutsch	English	Français	Espagnol	Nummer / Bemerkung / Note
003	0428 1060	001	ZYL. KOPFDICHTUNG	CYLIND.HEAD GASKET	JOINT DE CULASSE	JUNTA DE CULATA	<p>DICION, ESPESOR DE LA JUNTA -ESTADO LLEGADA (A)= ...MM -ESTADO MONTAJE (B)= ...MM PARA OTROS ESPESORES, VER POS. (C) DEPEND DU RESULTAT D MESURE, EPAISSEUR DE JOINT -ETAT DE LIVRAISON (A)= ...MM -ETAT DE MONTAGE (B)= ...MM AUTRES EPAISSEURS VOIR REP(C) A = 1,56 +/- 0.04 B = 1,48 C = POS. 4,5</p>
004	0428 1061	001	ZYL. KOPFDICHTUNG	CYLIND.HEAD GASKET	JOINT DE CULASSE	JUNTA DE CULATA	<p>VOM MESSERGEBNIS ABHAENGIG, DICHTUNGSDICKE -ANLIFERZUSTAND (A)= ...MM -EINBAUZUSTAND (B)= ...MM ANDERE DICKEN SIEHE POS. (C) GASKET THICKNESS DEPENDING ON MEASUREMENT RESULT -DELIVERY COND. (A)=...MM -INSTALLATION COND. (B)=...MM DIFF. THICKNESSES SEE ITEM (C) SEGUN EL RESULTADO DE LA ME- DICION, ESPESOR DE LA JUNTA -ESTADO LLEGADA (A)= ...MM -ESTADO MONTAJE (B)= ...MM PARA OTROS ESPESORES, VER POS. (C) DEPEND DU RESULTAT D MESURE, EPAISSEUR DE JOINT -ETAT DE LIVRAISON (A)= ...MM</p>

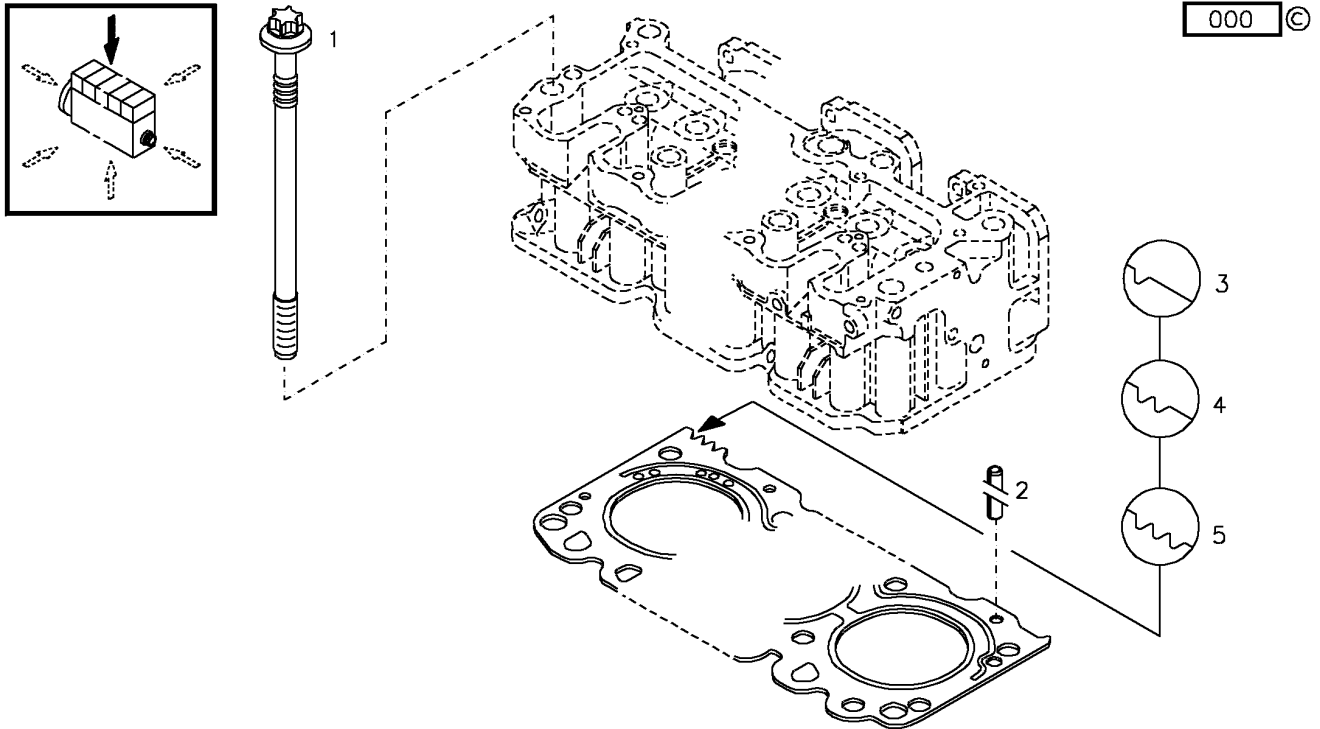

Pos	Teile -Nr.	Stk	Deutsch	English	Francais	Espagnol	Nummer / Bemerkung / Note
004	0428 1061	001	ZYL. KOPFDICHTUNG	CYLIND.HEAD GASKET	JOINT DE CULASSE	JUNTA DE CULATA	-ETAT DE MONTAGE (B)= ...MM AUTRES EPAISSEURS VOIR REP(C) A = 1,61 +/- 0.04 B = 1,55 C = POS.3.5
005	0428 1062	001	ZYL. KOPFDICHTUNG	CYLIND.HEAD GASKET	JOINT DE CULASSE	JUNTA DE CULATA	VOM MESSERGEBNIS ABHAENGIG, DICHTUNGSDICKE -ANLIFERZUSTAND (A)= ...MM -EINBAUZUSTAND (B)= ...MM ANDERE DICKEN SIEHE POS. (C) GASKET THICKNESS DEPENDING ON MEASUREMENT RESULT -DELIVERY COND. (A)=...MM -INSTALLATION COND. (B)=...MM DIFF. THICKNESSES SEE ITEM (C) SEGUN EL RESULTADO DE LA ME- DICION, ESPESOR DE LA JUNTA -ESTADO LLEGADA (A)= ...MM -ESTADO MONTAJE (B)= ...MM PARA OTROS ESPESORES, VER POS. (C) DEPEND DU RESULTAT D MESURE, EPAISSEUR DE JOINT -ETAT DE LIVRAISON (A)= ...MM -ETAT DE MONTAGE (B)= ...MM AUTRES EPAISSEURS VOIR REP(C) A=1.74 +/- 0.05 B=1.60 C= POS. 3.4

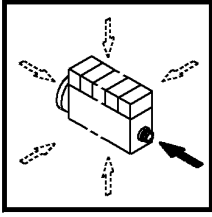

000 ©

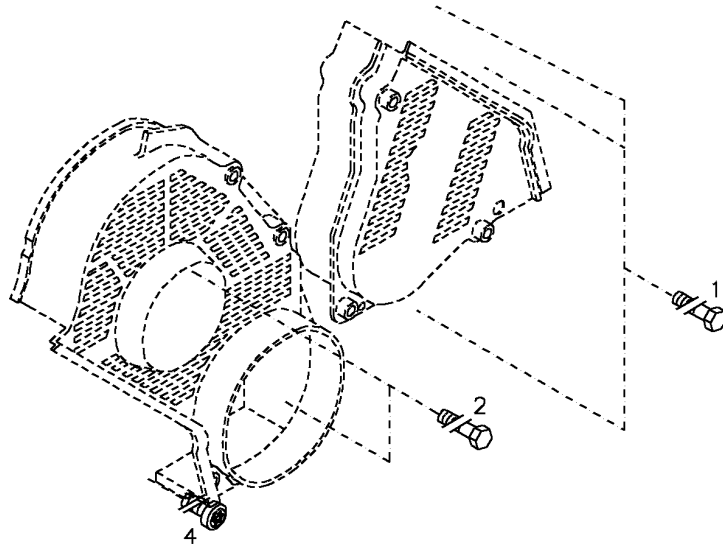

Pos	Teile -Nr.	Stk	Deutsch	English	Francais	Espagnol	Nummer / Bemerkung / Note
001	0111 1080	003	SECHSKANTSCHRAUBE	HEXAGON BOLT	VIS TETE HEXAGONAL	TORN.DE CABE.EXAG.	
002	0112 6975	002	SECHSKANTSCHRAUBE	HEXAGON BOLT	VIS TETE HEXAGONAL	TORN.DE CABE.EXAG.	
004	0211 2403	001	SICHERUNGSSCHRAUB	LOCKING SCREW	VIS D'ARRET	TORNILLO FIJACION	

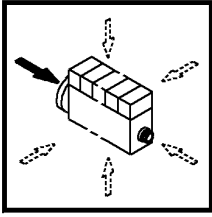

000 ©

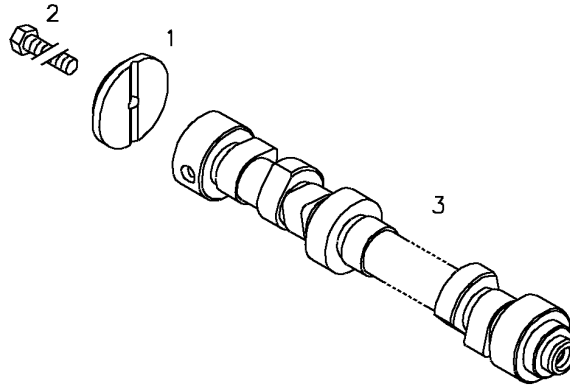

Pos	Teile -Nr.	Stk	Deutsch	English	Français	Espagnol	Nummer / Bemerkung / Note
001	0417 3067	001	ANLAUFSCHLEIBE	THRUST WASHER	RONDELLE DE BUTEE	ARANDELA TOPE	
002	0114 8241	001	SECHSKANTSCHRAUBE	HEXAGON BOLT	VIS TETE HEXAGONAL	TORN.DE CABE.EXAG.	
003	0428 6672	001	NOCKENWELLE	CAMSHAFT	ARBRE A CAMES	ARBOL DE LEVAS	

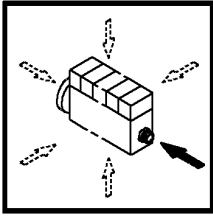

003 ©

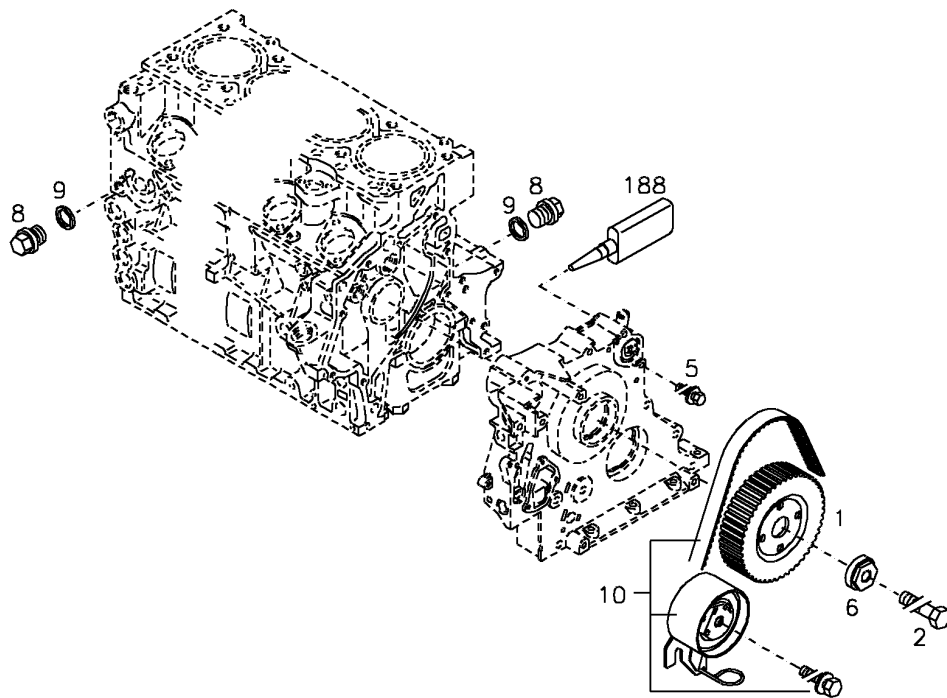

Pos	Teile -Nr.	Stk	Deutsch	English	Francais	Espagnol	Nummer / Bemerkung / Note
001	0428 6544	001	ZAHNRIEMENRAD	SYNCHR. BELT PULLEY	POULIE SYNCHRONE	RUED. CORREA DENTA	
002	0117 9934	001	SECHSKANTSCHRAUBE	HEXAGON BOLT	VIS TETE HEXAGONAL	TORN. DE CABE. EXAG.	
005	0118 1418	012	SECHSKANTSCHRAUBE	HEXAGON BOLT	VIS TETE HEXAGONAL	TORN. DE CABE. EXAG.	
006	0210 8176	001	SCHEIBE	PLAIN WASHER	RONDELLE PLATE	ARANDELA PLANA	
008	0114 8426	002	VERSCHLUSSSCHRAUB	SCREW PLUG	BOUCHON FILETE	TAPON ROSCADO	
009	0111 8669	002	DICHTRING	SEALING RING	BAGUE D'ETANCHEITE	JUNTA ANULAR	
010	0293 1485	001	REPARATURSATZ	REPAIR KIT	LOT DE REPARATION	LOTE REPARACIONES	
188	0101 6122	001	DICHTUNGSMASSE	PACKING COMPOUND	HERMETIC	PASTA HERMETIZANTE	

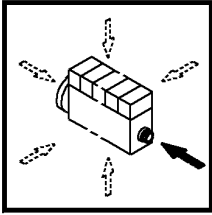

000 ©

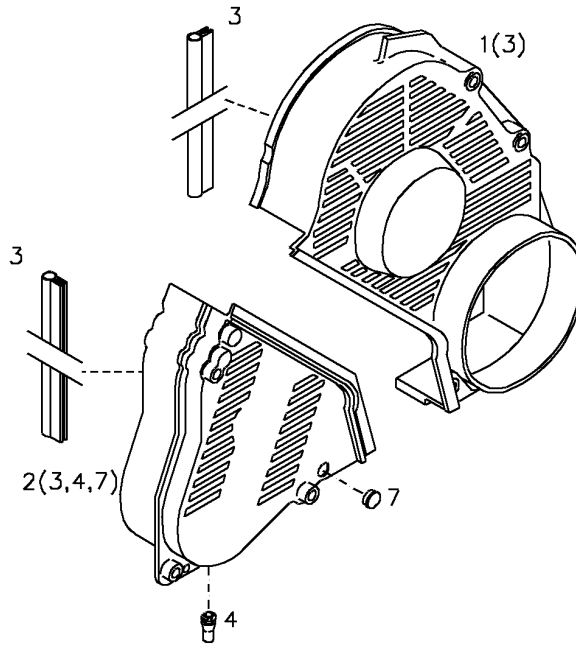

Pos	Teile -Nr.	Stk	Deutsch	English	Francais	Espagnol	Nummer / Bemerkung / Note
001	0428 6651	001	SCHUTZHAUBE	PROTECTION HOOD	CAPOT PROTECTEUR	CAPERUZA PROTECT.	MIT POS.... WITH ITEM.... CON POS. AVEC POSTE.... (3)
002	0428 6701	001	SCHUTZHAUBE	PROTECTION HOOD	CAPOT PROTECTEUR	CAPERUZA PROTECT.	MIT POS.... WITH ITEM.... CON POS. AVEC POSTE.... (3,4,7)
003	0139 8465	001	DICHTPROFIL	SEALING SECTION	PROFIL D'ETANCH	PERFIL HERMETIZAN.	
004	0428 0144	001	GUMMITUELLE	RUBBER GROMMET	MANCHON CAOUTCHO	FUNDA DE GOMA	
007	0117 9079	001	VERSCHLUSSTOPFEN	PLUG	BOUCHON	TAPON	

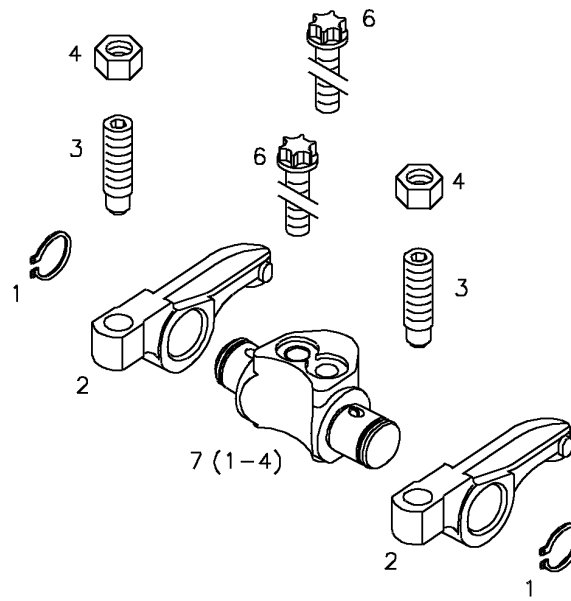

Pos	Teile -Nr.	Stk	Deutsch	English	Français	Espagnol	Nummer / Bemerkung / Note
001	0110 7727	002	SICHERUNGSRING	CIRCLIP	CIRCLIP	ANILLO D. SEGURIDAD	
002	0210 9628	002	KIPPHEBEL	ROCKER ARM	CULBUTEUR	BALANCIN	
003	0210 9636	002	EINSTELLSCHRAUBE	ADJUSTING SCREW	VIS DE REGLAGE	TORNILLO GRADUABLE	
004	0210 9637	002	SECHSKANTMUTTER	HEXAGON NUT	ECROU HEXAGONAL	TUERCA EXAGONAL	
006	0118 1417	002	TORX-SCHRAUBE	TORX-HEAD BOLT	VIS A TETE TORX	TORNILLO TEST.TORX	
007	0417 4058	001	KIPPHEBELBOCK	ROCKER ARM BRACKET	SUPPORT DE L'AXE	CABALLETE BALANCIN	MIT POS.... WITH ITEM.... CON POS. AVEC POSTE.... (1-4)

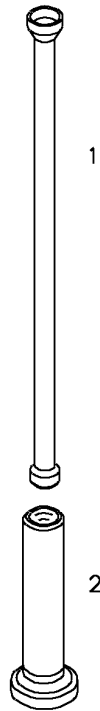

Pos	Teile -Nr.	Stk	Deutsch	English	Francais	Espagnol	Nummer / Bemerkung / Note
001	0210 9085	002	STOSSSTANGE	PUSHROD	TIGE DE CULBUTEUR	BARRA DE EMPUJE	
002	0417 8075	002	VENTILSTOESSEL	VALVE TAPPET	POUSSOIR	TAQUE DE VALVULA	

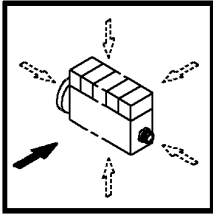

000 ©

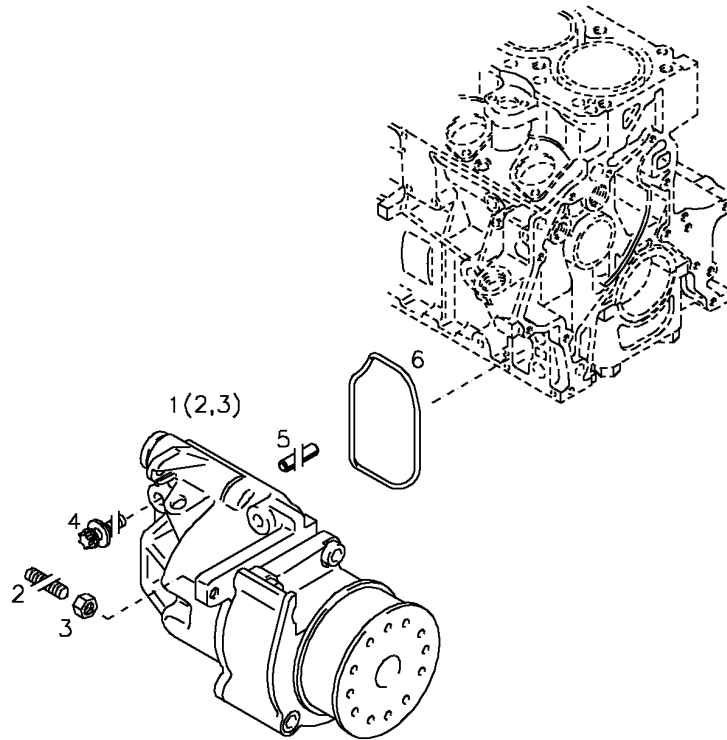

Pos	Teile -Nr.	Stk	Deutsch	English	Français	Espagnol	Nummer / Bemerkung / Note
001	0428 0165	001	SCHMIEROELPUMPE	LUBRICAT. OIL PUMP	POMPE	BOMBA ACEITE LUBR.	MIT POS.... WITH ITEM.... CON POS. AVEC POSTE.... (2,3)
002	0114 8123	001	GEWINDESTIFT	SET SCREW	VIS SANS TETE	TORNILL SIN CABEZA	
003	0114 8122	001	SECHSKANTMUTTER	HEXAGON NUT	ECROU HEXAGONAL	TUERCA EXAGONAL	
004	0118 1424	004	TORX-SCHRAUBE	TORX-HEAD BOLT	VIS A TETE TORX	TORNILLO TEST.TORX	
005	0417 8612	002	SPIRAL-SPANNSTIFT	SPIRAL PIN	GOUPILLE HELIC	PASADOR ESPIRAL	
006	0417 8989	001	FORMDICHTRING	SEALINGRING	BAGUE-JOINT PROF.	ANILLO JUNTA PERF.	

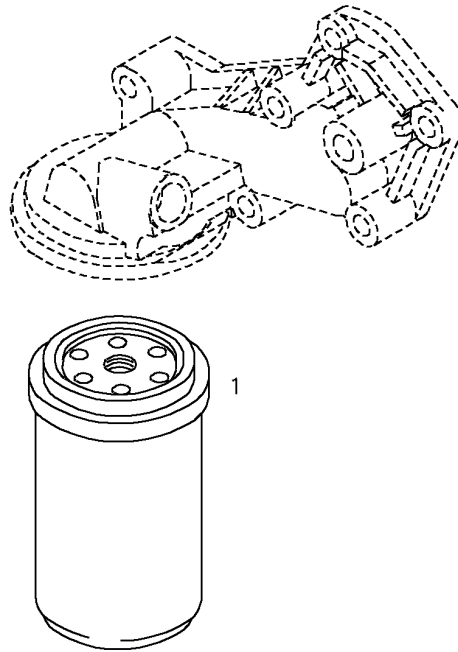

Pos	Teile -Nr.	Stk	Deutsch	English	Francais	Espagnol	Nummer / Bemerkung / Note
001	0117 4416	001	SCHMIEROELWE.FILT.	SPIN-ON OIL FILTER	FILT.A HUILE VISSE	FILT.INTERC.P.ACEI	

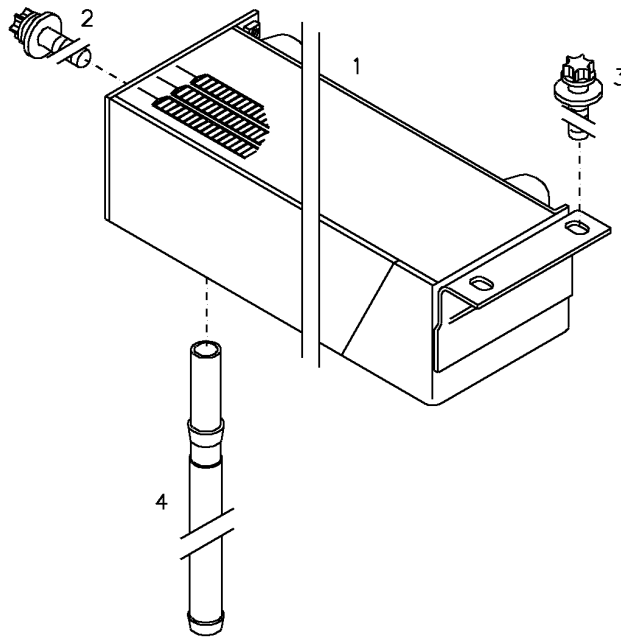
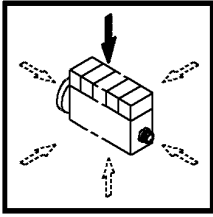

Pos	Teile -Nr.	Stk	Deutsch	English	Francais	Espagnol	Nummer / Bemerkung / Note
001	0428 1090	001	OELKUEHLER	OIL COOLER	REFROIDISSEUR	ENFRIADOR D.ACEITE	
002	0117 9622	002	TORX-SCHRAUBE	TORX-HEAD BOLT	VIS A TETE TORX	TORNILLO TEST.TORX	
003	0118 2004	002	TORX-SCHRAUBE	TORX-HEAD BOLT	VIS A TETE TORX	TORNILLO TEST.TORX	
004	0417 9404	002	STECKSTUECK	PLUG	PIECE A ENFICHER	PIEZA DE ENCHUFE	

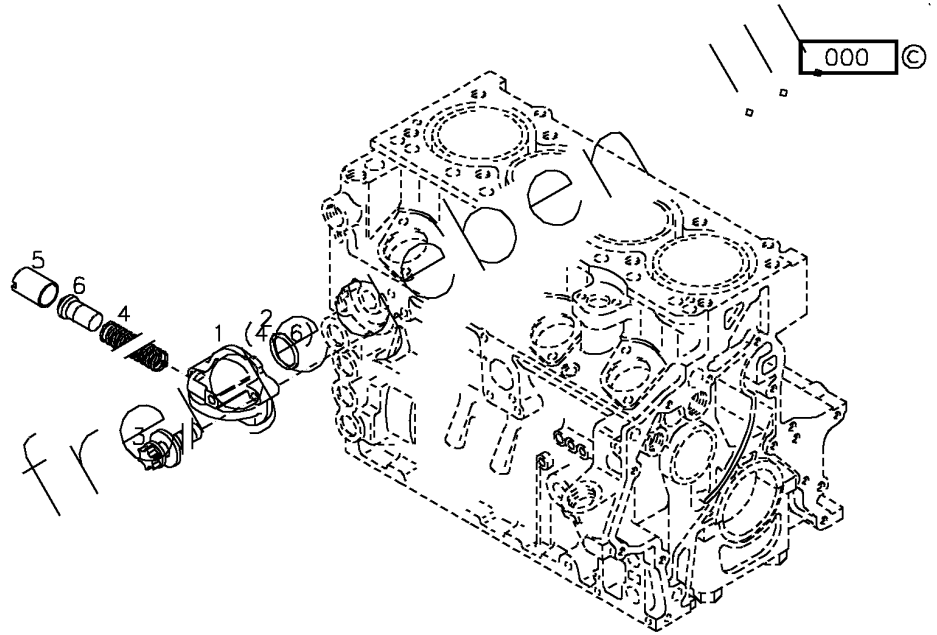
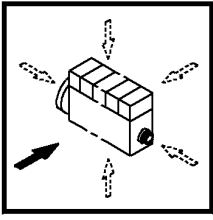

Nicht freigegeben

Pos	Teile -Nr.	Stk	Deutsch	English	Francais	Espagnol	Nummer / Bemerkung / Note
001	0428 1204	001	FILTERKONSOLE	BRACKET	CONSOLE DE FILTRE	CONSOLA DEL FILTRO	MIT POS.... WITH ITEM.... CON POS AVEC POSTE.... (4-6)
002	0428 1205	001	DICHTUNG	GASKET	GARNITURE/JOINT	JUNTA	
003	0118 1425	002	TORX-SCHRAUBE	TORX-HEAD BOLT	VIS A TETE TORX	TORNILLO TEST.TORX	
004	0425 8758	001	DRUCKFEDER	COMPRESSION SPRING	RESSORT DE PRESS.	RESORTE DE PRESION	
005	0425 8757	001	REGELSCHIEBER	CONTROL VALVE	TIROIR DE REGLAGE	CORREDERA REGULAC	
006	0425 8759	001	TEMPERATURFUEHLER	TEMPERATURE SENSO	SONDE THERMOMETR.	SONDA TERMICA	

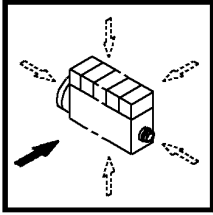

000 ©

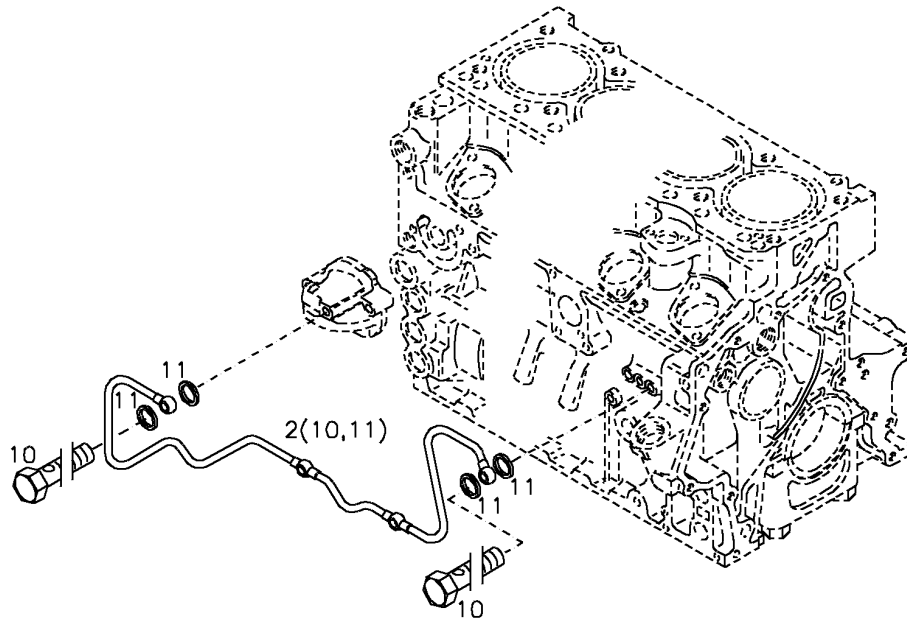

Pos	Teile -Nr.	Stk	Deutsch	English	Francais	Espagnol	Nummer / Bemerkung / Note
002	0428 1321	001	STEUERLEITUNG	PILOT LINE	CONDUIT D.PILOTAGE	TUBERIA DE MANDO	MIT POS.... WITH ITEM.... CON POS. AVEC POSTE.... (10,11)
010	0223 1136	004	HOHLSCHRAUBE	HOLLOW SCREW	VIS BANJO	TORNILLO HUECO	
011	0111 8659	008	DICHRING	SEALING RING	BAGUE D'ETANCHEITE	JUNTA ANULAR	

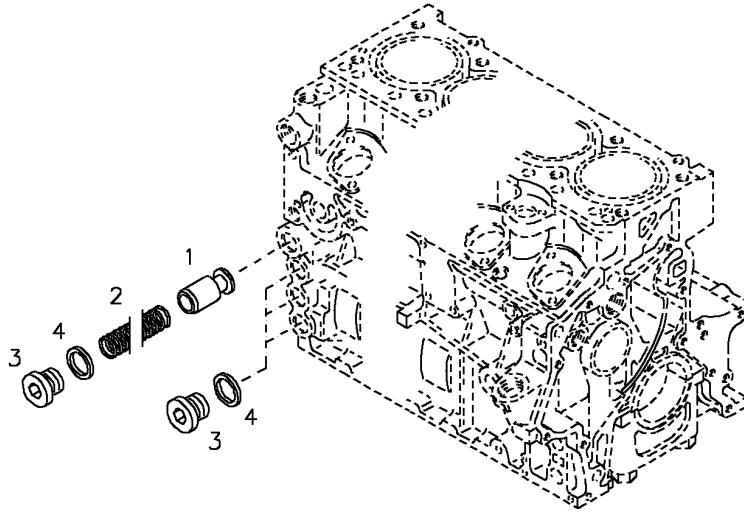

Pos	Teile -Nr.	Stk	Deutsch	English	Francais	Espagnol	Nummer / Bemerkung / Note
001	0417 8390	001	VENTIL	VALVE	SOUPAPE/ROBINET	VALVULA	
002	0417 8423	001	DRUCKFEDER	COMPRESSION SPRING	RESSORT DE PRESS.	RESORTE DE PRESION	
003	0110 0483	004	VERSCHLUSSSCHRAUB	SCREW PLUG	BOUCHON FILETE	TAPON ROSCADO	
004	0111 8748	004	DICHTRING	SEALINGRING	BAGUE D'ETANCHEITE	JUNTA ANULAR	

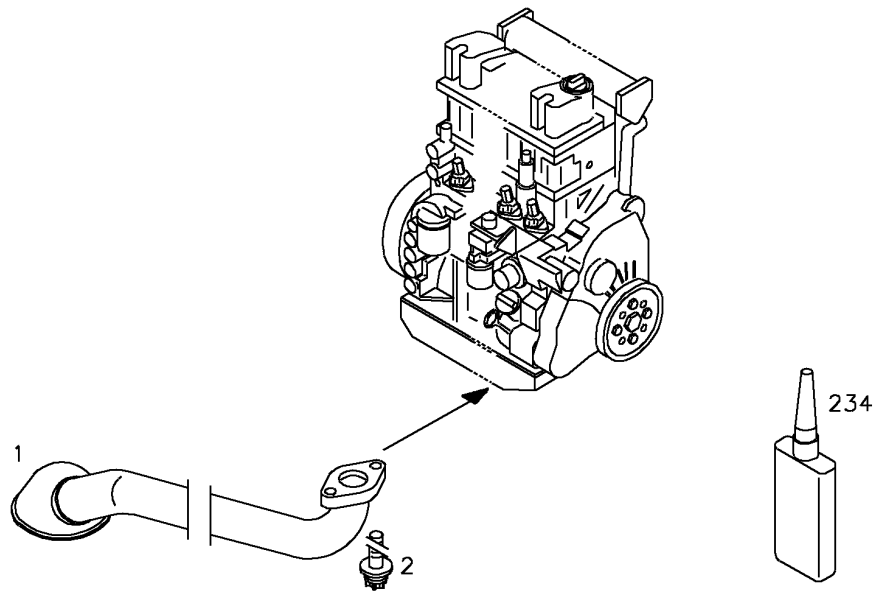

Pos	Teile -Nr.	Stk	Deutsch	English	Francais	Espagnol	Nummer / Bemerkung / Note
001	0417 8205	001	OELSAUGROHR	OIL SUCTION PIPE	TUBULURE D'ASPIRAT	TUBO ASPIR.ACEITE	
002	0118 1422	002	TORX-SCHRAUBE	TORX-HEAD BOLT	VIS A TETE TORX	TORNILLO TEST.TORX	
234	0101 6024	001	DICHTUNGSMASSE	PACKING COMPOUND	HERMETIC	PASTA HERMETIZANTE	

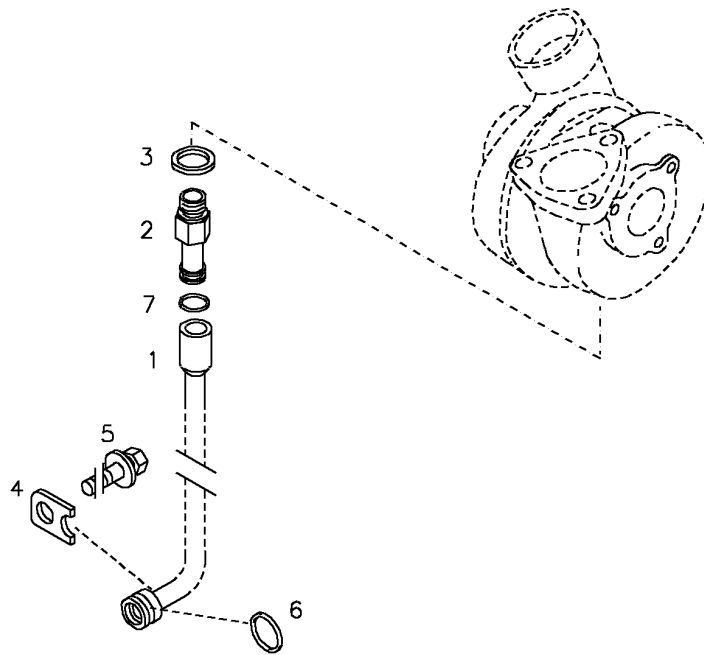

Pos	Teile -Nr.	Stk	Deutsch	English	Francais	Espagnol	Nummer / Bemerkung / Note
001	0427 0443	001	OELRUECKLAUFLEITG	OIL RETURN LINE	TUY.RETOUR D'HUILE	TUBO RETOR.D.ACEIT	
002	0420 7255	001	EINSCHRAUBSTUTZEN	SCREW-IN NIPPLE	TUBULURE A VIS	ACOPLAM.TUBULAR	
003	0111 8700	001	DICHTRING	SEALINGRING	BAGUE D'ETANCHEITE	JUNTA ANULAR	
004	0427 1160	001	HALTEBLECH	RETAINING PLATE	TOLE DE RETENUE	CHAPA DE SUJECION	
005	0118 1419	001	SECHSKANTSCHRAUBE	HEXAGON BOLT	VIS TETE HEXAGONAL	TORN.DE CABE.EXAG.	
006	0118 1872	001	RUNDDICHTRING	O-SEAL	ANNEAU TORIQUE	JUNTA TORNICA	
007	0118 0079	001	RUNDDICHTRING	O-SEAL	ANNEAU TORIQUE	JUNTA TORNICA	

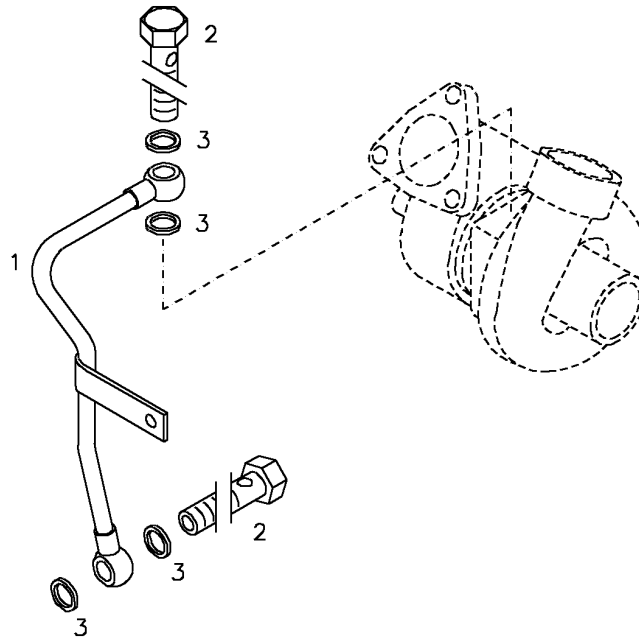

Pos	Teile -Nr.	Stk	Deutsch	English	Francais	Espagnol	Nummer / Bemerkung / Note
001	0427 0503	001	SCHMIEROELLEITUNG	LUBRICAT. OIL LINE	CONDUITE A HUILE	TUBER. ACEITE LUBR.	
002	0111 9241	002	HOHLSCHRAUBE	HOLLOW SCREW	VIS BANJO	TORNILLO HUECO	
003	0111 8673	004	DICHTRING	SEALINGRING	BAGUE D'ETANCHEITE	JUNTA ANULAR	

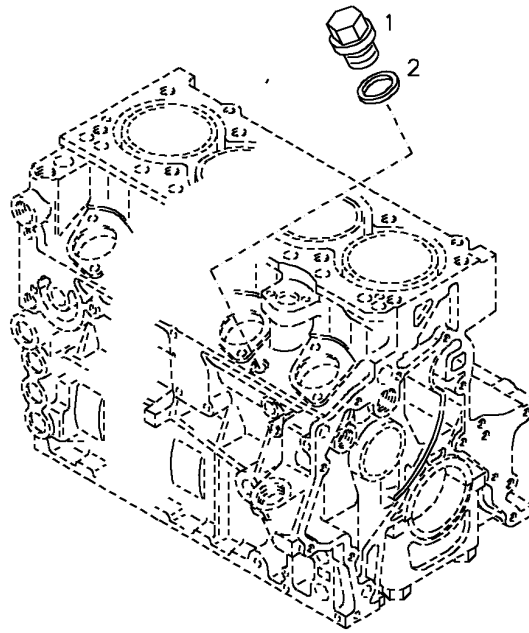

Pos	Teile -Nr.	Stk	Deutsch	English	Francais	Espagnol	Nummer / Bemerkung / Note
001	0111 0433	001	VERSCHLUSSSCHRAUB	SCREW PLUG	BOUCHON FILETE	TAPON ROSCADO	
002	0111 8669	001	DICHTRING	SEALINGRING	BAGUE D'ETANCHEITE	JUNTA ANULAR	

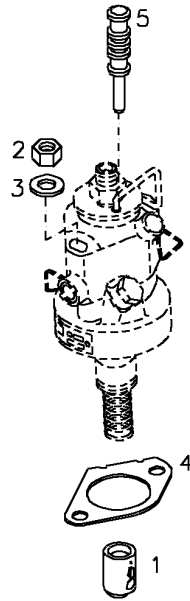
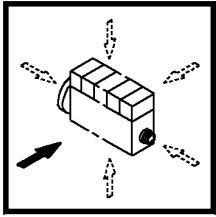

Pos	Teile -Nr.	Stk	Deutsch	English	Francais	Espagnol	Nummer / Bemerkung / Note
001	0428 6793	001	ROLLENSTOESSEL	ROLLER TAPPET	POUSSOIR A GALET	TAQUE DE RODILLO	
002	0111 2824	002	SECHSKANTMUTTER	HEXAGON NUT	ECROU HEXAGONAL	TUERCA EXAGONAL	
003	0240 4201	002	SCHEIBE	PLAIN WASHER	RONDELLE PLATE	ARANDELA PLANA	
004	0417 8522	001	AUSGLEICHDICHTUNG	COMPENSAT GASKET	JOINT DE COMPENS	JUNTA COMPENSADOR	VOM MESSERGESBNIS ABHAENGIG, DICHTUNGSDICKE (A)= MM ANDERE DICKEN SIEHE POS. (B) GASKET THICKNESS DEPENDING ON MEASUREMENT RESULT (A)= MM DIFF. THICKNESSES SEE ITEM (B) SEGUN EL RESULTADO DE LA ME- DICION, ESPESOR DE LA JUNTA (A)= MM PARA OTROS ESPESORES, VER POS. (B) DEPEND DU RESULTAT D MESURE, EPAISSEUR DE JOINT (A)= MM AUTRES EPAISSEURS VOIR REP(B) (A) = 0,35MM
005	0428 6122	001	VERSCHLUSSTOPFEN	PLUG	BOUCHON	TAPON	
951	0428 6587	001	AUSGLEICHDICHTUNG	COMPENSAT GASKET	JOINT DE COMPENS	JUNTA COMPENSADORMM DICKMM THICKNESS ESPESOR:....MMMM D'EPAISSEUR 0,40MM
952	0417 8523	001	AUSGLEICHDICHTUNG	COMPENSAT GASKET	JOINT DE COMPENS	JUNTA COMPENSADORMM DICKMM THICKNESS ESPESOR:....MMMM D'EPAISSEUR 0,45MM
953	0428 6588	001	AUSGLEICHDICHTUNG	COMPENSAT GASKET	JOINT DE COMPENS	JUNTA COMPENSADORMM DICKMM THICKNESS ESPESOR:....MMMM D'EPAISSEUR 0,50MM

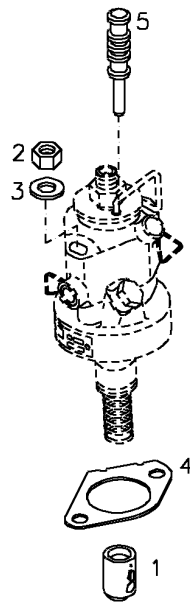
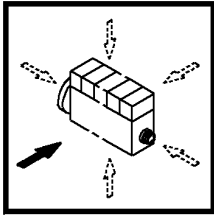

Pos	Teile -Nr.	Stk	Deutsch	English	Francais	Espagnol	Nummer / Bemerkung / Note
954	0417 8524	001	AUSGLEICHDICHTUNG	COMPENSAT GASKET	JOINT DE COMPENS	JUNTA COMPENSADORMM DICKMM THICKNESS ESPESOR:.....MMMM D'EPAISSEUR 0,55MM
955	0428 6589	001	AUSGLEICHDICHTUNG	COMPENSAT GASKET	JOINT DE COMPENS	JUNTA COMPENSADORMM DICKMM THICKNESS ESPESOR:.....MMMM D'EPAISSEUR 0,60MM
956	0417 8525	001	AUSGLEICHDICHTUNG	COMPENSAT GASKET	JOINT DE COMPENS	JUNTA COMPENSADORMM DICKMM THICKNESS ESPESOR:.....MMMM D'EPAISSEUR 0,65MM
957	0428 6590	001	AUSGLEICHDICHTUNG	COMPENSAT GASKET	JOINT DE COMPENS	JUNTA COMPENSADORMM DICKMM THICKNESS ESPESOR:.....MMMM D'EPAISSEUR 0,70MM
958	0417 8526	001	AUSGLEICHDICHTUNG	COMPENSAT GASKET	JOINT DE COMPENS	JUNTA COMPENSADORMM DICKMM THICKNESS ESPESOR:.....MMMM D'EPAISSEUR 0,75MM
959	0428 6591	001	AUSGLEICHDICHTUNG	COMPENSAT GASKET	JOINT DE COMPENS	JUNTA COMPENSADORMM DICKMM THICKNESS ESPESOR:.....MMMM D'EPAISSEUR 0,80MM
960	0417 8527	001	AUSGLEICHDICHTUNG	COMPENSAT GASKET	JOINT DE COMPENS	JUNTA COMPENSADORMM DICKMM THICKNESS ESPESOR:.....MMMM D'EPAISSEUR

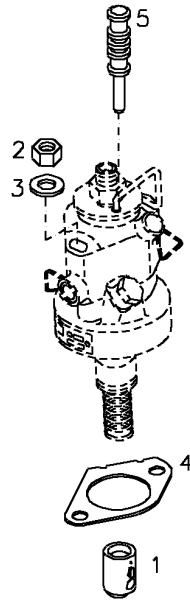
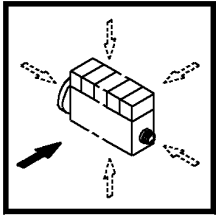

Pos	Teile -Nr.	Stk	Deutsch	English	Francais	Espagnol	Nummer / Bemerkung / Note
960	0417 8527	001	AUSGLEICHDICHTUNG	COMPENSAT GASKET	JOINT DE COMPENS	JUNTA COMPENSADOR	0,85MM
961	0428 1633	001	AUSGLEICHDICHTUNG	COMPENSAT GASKET	JOINT DE COMPENS	JUNTA COMPENSADORMM DICKMM THICKNESS ESPESOR:....MMMM D'EPAISSEUR 0,90MM
962	0417 8528	001	AUSGLEICHDICHTUNG	COMPENSAT GASKET	JOINT DE COMPENS	JUNTA COMPENSADORMM DICKMM THICKNESS ESPESOR:....MMMM D'EPAISSEUR 0,95MM
963	0428 1634	001	AUSGLEICHDICHTUNG	COMPENSAT GASKET	JOINT DE COMPENS	JUNTA COMPENSADORMM DICKMM THICKNESS ESPESOR:....MMMM D'EPAISSEUR 1,00MM
964	0427 2923	001	AUSGLEICHDICHTUNG	COMPENSAT GASKET	JOINT DE COMPENS	JUNTA COMPENSADORMM DICKMM THICKNESS ESPESOR:....MMMM D'EPAISSEUR 1,05MM
965	0428 6592	001	AUSGLEICHDICHTUNG	COMPENSAT GASKET	JOINT DE COMPENS	JUNTA COMPENSADORMM DICKMM THICKNESS ESPESOR:....MMMM D'EPAISSEUR 1,10MM
966	0427 2924	001	AUSGLEICHDICHTUNG	COMPENSAT GASKET	JOINT DE COMPENS	JUNTA COMPENSADORMM DICKMM THICKNESS ESPESOR:....MMMM D'EPAISSEUR 1,15MM
967	0428 6593	001	AUSGLEICHDICHTUNG	COMPENSAT GASKET	JOINT DE COMPENS	JUNTA COMPENSADORMM DICKMM THICKNESS ESPESOR:....MM

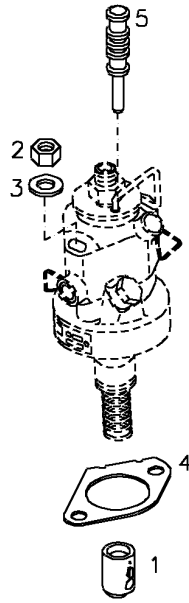
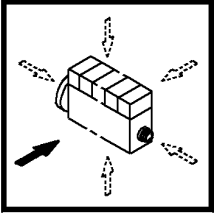

Pos	Teile -Nr.	Stk	Deutsch	English	Francais	Espagnol	Nummer / Bemerkung / Note
967	0428 6593	001	AUSGLEICHDICHTUNG	COMPENSAT GASKET	JOINT DE COMPENS	JUNTA COMPENSADORMM D'EPAISSEUR 1,20MM
968	0428 1635	001	AUSGLEICHDICHTUNG	COMPENSAT GASKET	JOINT DE COMPENS	JUNTA COMPENSADORMM DICKMM THICKNESS ESPESOR:.....MMMM D'EPAISSEUR 1,25MM
969	0428 6696	001	AUSGLEICHDICHTUNG	COMPENSAT GASKET	JOINT DE COMPENS	JUNTA COMPENSADORMM DICKMM THICKNESS ESPESOR:.....MMMM D'EPAISSEUR 1,30MM

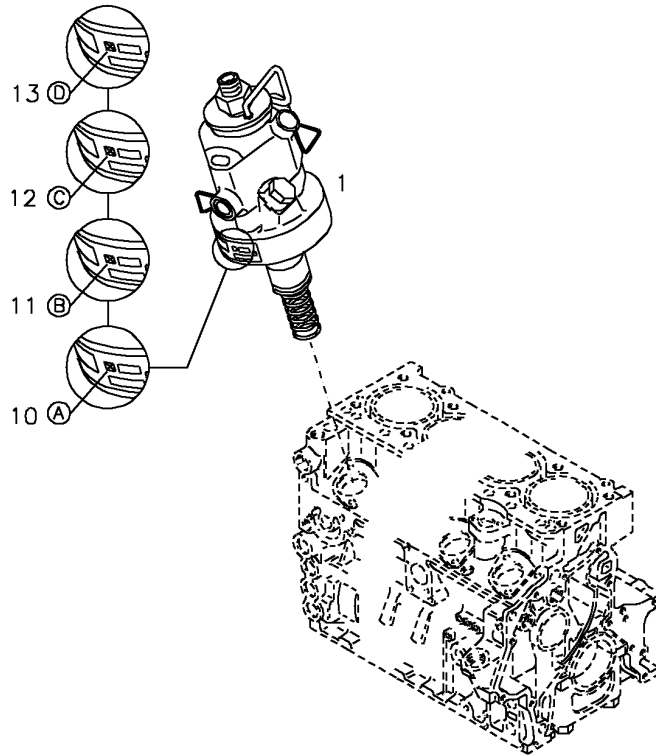
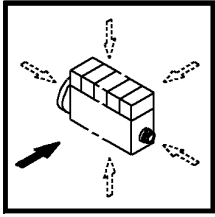

000 ©

Pos	Teile -Nr.	Stk	Deutsch	English	Francais	Espagnol	Nummer / Bemerkung / Note
001	0428 6792	001	EINSPRITZPUMPE	FUEL INJECT. PUMP	POMPE D'INJECTION	BOMBA DE INYECCION	
010	0134 0330	001	EINSPRITZPUMPE	FUEL INJECT. PUMP	POMPE D'INJECTION	BOMBA DE INYECCION	Pumpenklasse - A -
011	0134 0331	001	EINSPRITZPUMPE	FUEL INJECT. PUMP	POMPE D'INJECTION	BOMBA DE INYECCION	Pumpenklasse - B -
012	0134 0332	001	EINSPRITZPUMPE	FUEL INJECT. PUMP	POMPE D'INJECTION	BOMBA DE INYECCION	Pumpenklasse - C -
013	0134 0333	001	EINSPRITZPUMPE	FUEL INJECT. PUMP	POMPE D'INJECTION	BOMBA DE INYECCION	Pumpenklasse - D -

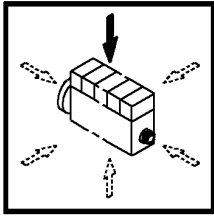

000 ©

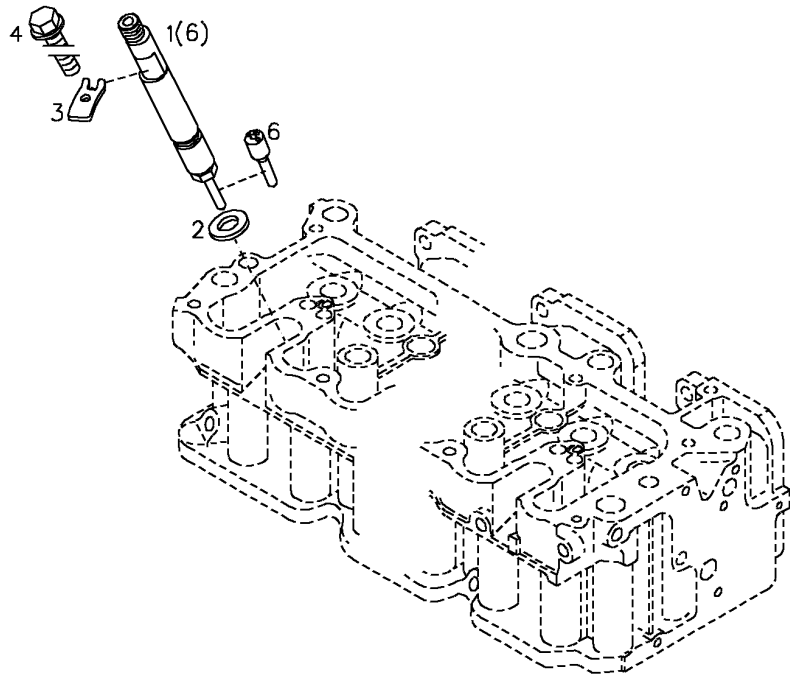

Pos	Teile -Nr.	Stk	Deutsch	English	Francais	Espagnol	Nummer / Bemerkung / Note
001	0428 6251	001	EINSPRITZVENTIL	FUEL INJECTOR	PORTE-INJECTEUR	INYECTOR	MIT POS.... WITH ITEM.... CON POS AVEC POSTE.... (6)
002	0428 6236	001	DICHTRING	SEALINGRING	BAGUE D'ETANCHEITE	JUNTA ANULAR	
003	0428 1147	001	PRATZE	CLAW	GRIFFE	PATA	
004	0118 1433	001	SECHSKANTSCHRAUBE	HEXAGON BOLT	VIS TETE HEXAGONAL	TORN.DE CABE.EXAG.	
006	0428 1859	001	DUESENELEMENT	NOZZLE ELEMENT	GARNITUR INJECTEUR	ELEMENTO DE TOBERA	



FILTERPATRONE
FILTER CARTRIDGE
CARTOUCHE FILTRANT
CARTUCHO FILTRO

20 - 0506 7542

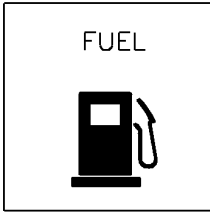

000 ©

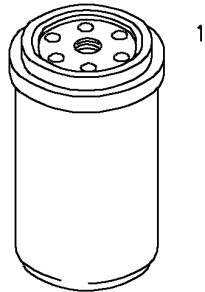

Pos	Teile -Nr.	Stk	Deutsch	English	Francais	Espagnol	Nummer / Bemerkung / Note
001	0117 4482	001	KRAFTSTOFFWE.FILT.	SPIN-ON FUEL FILT.	FILT.A CARBU.VISSE	FILT.IC.P.COMBUST.	

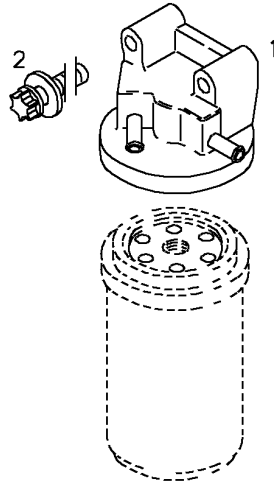

Pos	Teile -Nr.	Stk	Deutsch	English	Francais	Espagnol	Nummer / Bemerkung / Note
001	0417 8691	001	KONSOLE	BRACKET	CONSOLE	CONSOLA	
002	0118 1425	002	TORX-SCHRAUBE	TORX-HEAD BOLT	VIS A TETE TORX	TORNILLO TEST.TORX	

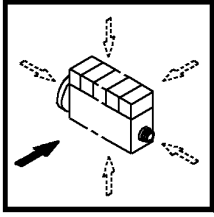

000 ©

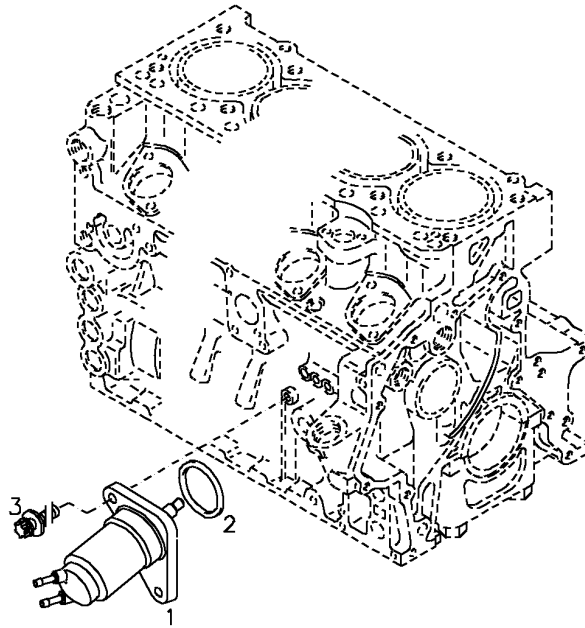

Pos	Teile -Nr.	Stk	Deutsch	English	Francais	Espagnol	Nummer / Bemerkung / Note
001	0428 6113	001	KR.STOFF-FOERD.PPE	FUEL SUPPLY PUMP	POMPE ALIMENT.COMB	BOMBA ALIMENT.COMB	
002	0118 2349	001	RUNDDICHTRING	O-SEAL	ANNEAU TORIQUE	JUNTA TORNICA	
003	0118 1421	002	TORX-SCHRAUBE	TORX-HEAD BOLT	VIS A TETE TORX	TORNILLO TEST.TORX	

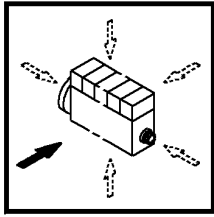

000 ©

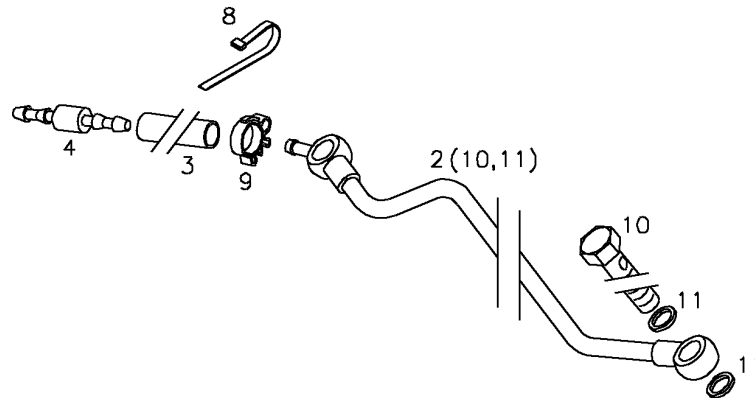

Pos	Teile -Nr.	Stk	Deutsch	English	Français	Espagnol	Nummer / Bemerkung / Note
002	0428 1429	001	KRAFTSTOFFLEITUNG	FUEL LINE	CONDUITE COMBUST.	TUBERIA COMBUSTIB.	MIT POS.... WITH ITEM.... CON POS. AVEC POSTE.... (10,11)
003	0117 7045	001	GUMMISCHLAUCH	RUBBER HOSE	FLEXIBLE CAOUTCH	MANGUERA DE GOMA	
004	0118 2135	001	VERBINDUNGSSTUECK	CONNECTING PIECE	RACCORD	PIEZA DE CONEXION	
008	0117 6435	001	HALTEBAND	CLAMPING BAND	BANDE DE SERRAGE	FLEJE DE SUJECION	
009	0118 0014	001	SCHLAUCHSCHELLE	HOSE CLIP	COLLIER DE SERRAGE	ABRAZADER MANGUER	
010	0111 9241	004	HOHLSCHRAUBE	HOLLOW SCREW	VIS BANJO	TORNILLO HUECO	
011	0118 1985	008	DICHTRING	SEALING RING	BAGUE D'ETANCHEITE	JUNTA ANULAR	

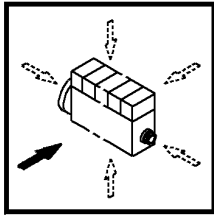

000 ©

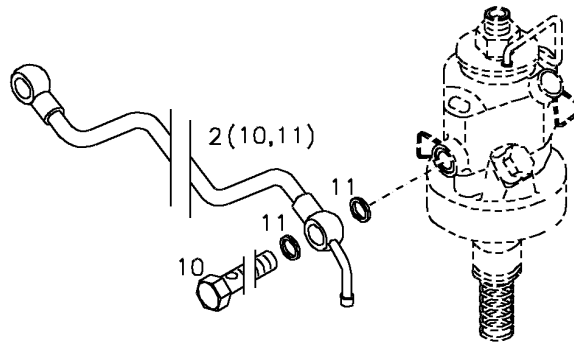

Pos	Teile -Nr.	Stk	Deutsch	English	Francais	Espagnol	Nummer / Bemerkung / Note
002	0428 1870	001	KRAFTSTOFFLEITUNG	FUEL LINE	CONDUITE COMBUST.	TUBERIA COMBUSTIB.	MIT POS.... WITH ITEM.... CON POS. AVEC POSTE.... (10,11)
010	0111 9241	002	HOHLSCHRAUBE	HOLLOW SCREW	VIS BANJO	TORNILLO HUECO	
011	0118 1985	004	DICHTRING	SEALINGRING	BAGUE D'ETANCHEITE	JUNTA ANULAR	



EINSPRITZLEITUNG
HIGH PRESSURE PIPE
TUYAUTERIE
TUBERIA INYECCION

21 - 0507 9015

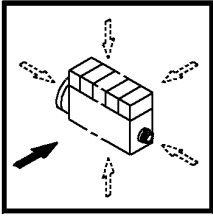

000 ©

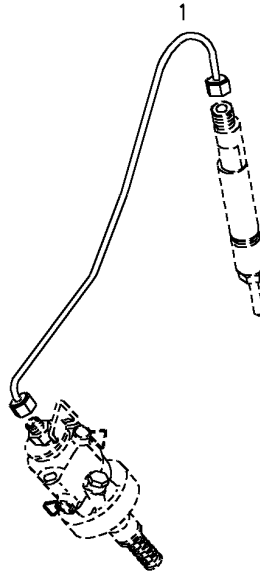

Pos	Teile -Nr.	Stk	Deutsch	English	Francais	Espagnol	Nummer / Bemerkung / Note
001	0428 1876	001	EINSPRITZLEITUNG	HIGH PRESSURE PIPE	TUYAUTERIE	TUBERIA INYECCION	

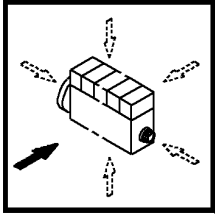

000 ©

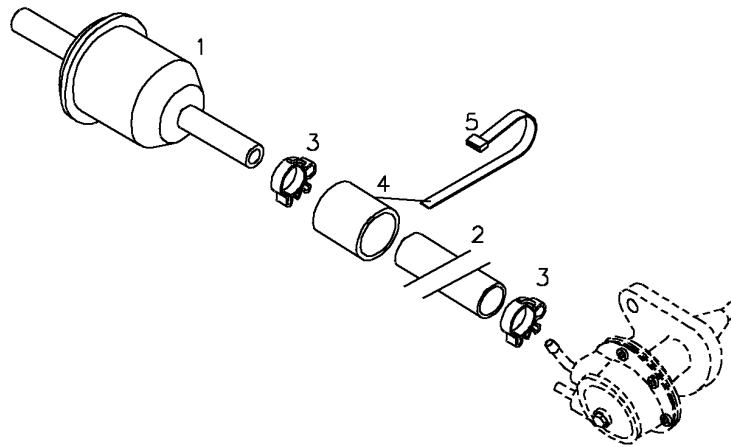

Pos	Teile -Nr.	Stk	Deutsch	English	Francais	Espagnol	Nummer / Bemerkung / Note
001	0117 8753	001	KRAFTSTOFFFILTER	FUEL FILTER	FILTRE A COMBUST.	FILTRO COMBUSTIBLE	
002	0117 9656	001	GUMMISCHLAUCH	RUBBER HOSE	FLEXIBLE CAOUTCH	MANGUERA DE GOMA	
003	0118 0014	002	SCHLAUCHSCHELLE	HOSE CLIP	COLLIER DE SERRAGE	ABRAZADER MANGUER	
004	0140 4948	160	SCHLAUCH	HOSE	FLEXIBLE	MANGUERA	
005	0117 6435	001	HALTEBAND	CLAMPING BAND	BANDE DE SERRAGE	FLEJE DE SUJECION	

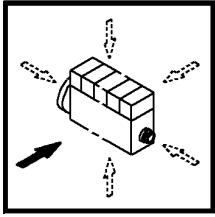

000 ©

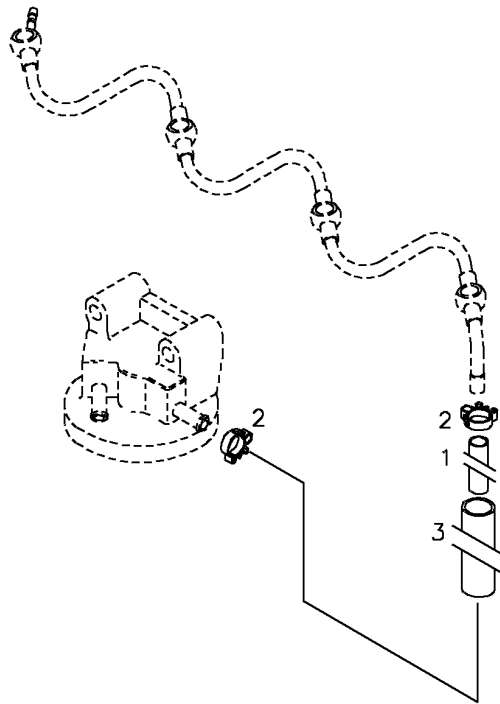

Pos	Teile -Nr.	Stk	Deutsch	English	Français	Espagnol	Nummer / Bemerkung / Note
001	0118 1695	001	GUMMISCHLAUCH	RUBBER HOSE	FLEXIBLE CAOUTCH	MANGUERA DE GOMA	
002	0118 0014	002	SCHLAUCHSCHELLE	HOSE CLIP	COLLIER DE SERRAGE	ABRAZADER MANGUER	
003	0140 4949	001	SCHLAUCH	HOSE	FLEXIBLE	MANGUERA	

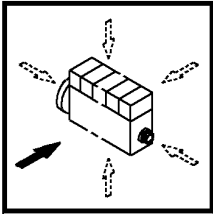

000 ©

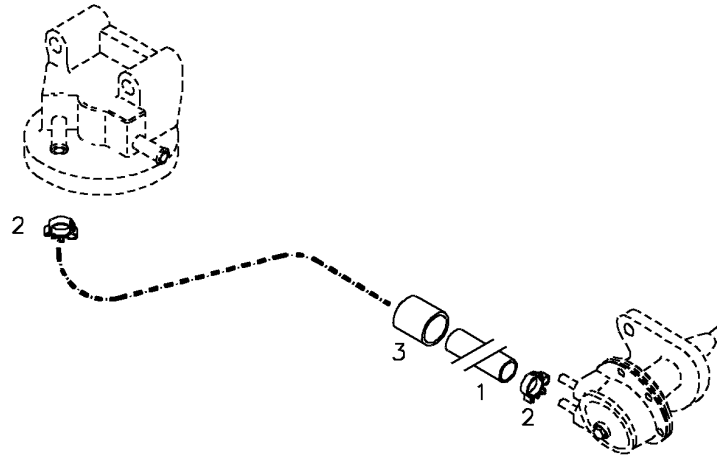

Pos	Teile -Nr.	Stk	Deutsch	English	Francais	Espagnol	Nummer / Bemerkung / Note
001	0118 2348	001	GUMMISCHLAUCH	RUBBER HOSE	FLEXIBLE CAOUTCH	MANGUERA DE GOMA	
002	0118 0014	002	SCHLAUCHSCHELLE	HOSE CLIP	COLLIER DE SERRAGE	ABRAZADER MANGUER	
003	0140 4950	001	SCHLAUCH	HOSE	FLEXIBLE	MANGUERA	

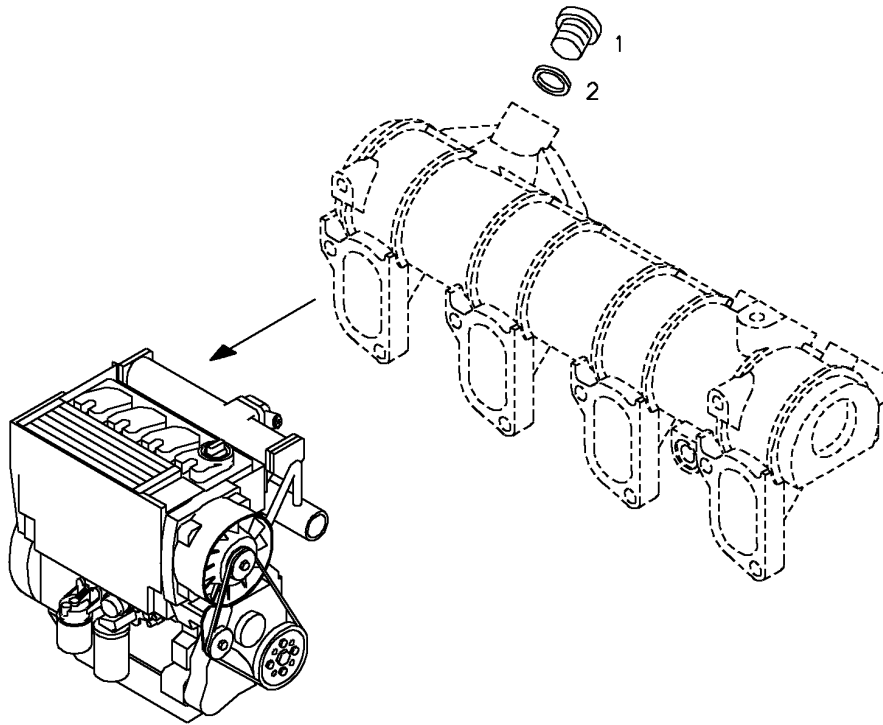

Pos	Teile -Nr.	Stk	Deutsch	English	Francais	Espagnol	Nummer / Bemerkung / Note
001	0114 4536	001	VERSCHLUSSSCHRAUB	SCREW PLUG	BOUCHON FILETE	TAPON ROSCADO	
002	0111 8737	001	DICHTRING	SEALINGRING	BAGUE D'ETANCHEITE	JUNTA ANULAR	

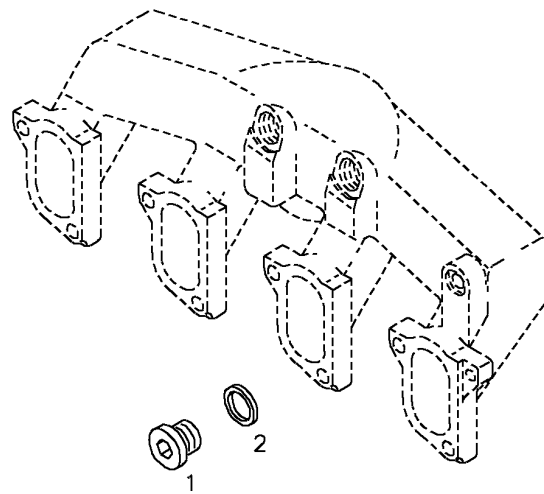

Pos	Teile -Nr.	Stk	Deutsch	English	Francais	Espagnol	Nummer / Bemerkung / Note
001	0113 1075	001	VERSCHLUSSSCHRAUB	SCREW PLUG	BOUCHON FILETE	TAPON ROSCADO	
002	0111 8664	001	DICHTRING	SEALINGRING	BAGUE D'ETANCHEITE	JUNTA ANULAR	

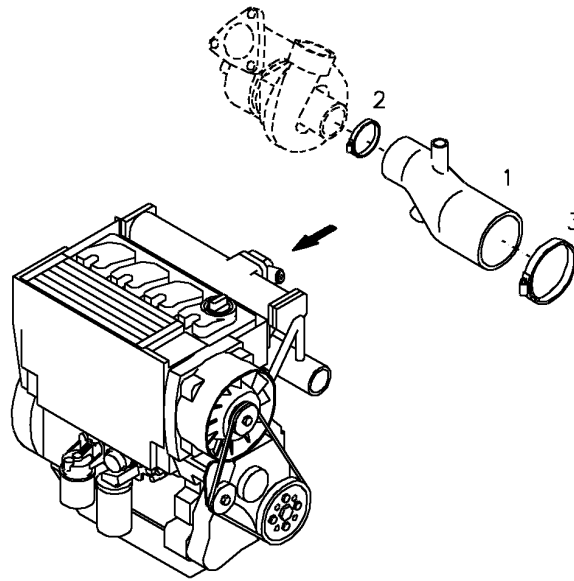

Pos	Teile -Nr.	Stk	Deutsch	English	Francais	Espagnol	Nummer / Bemerkung / Note
001	0427 1258	001	REDUZIERSTUECK	REDUCER	PIECE DE REDUCTION	PIEZA DE REDUCCION	
002	0117 3941	001	SCHLAUCHSCHELLE	HOSE CLIP	COLLIER DE SERRAGE	ABRAZADER MANGUER	
003	0117 3940	001	SCHLAUCHSCHELLE	HOSE CLIP	COLLIER DE SERRAGE	ABRAZADER MANGUER	

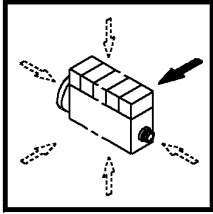

000 ©

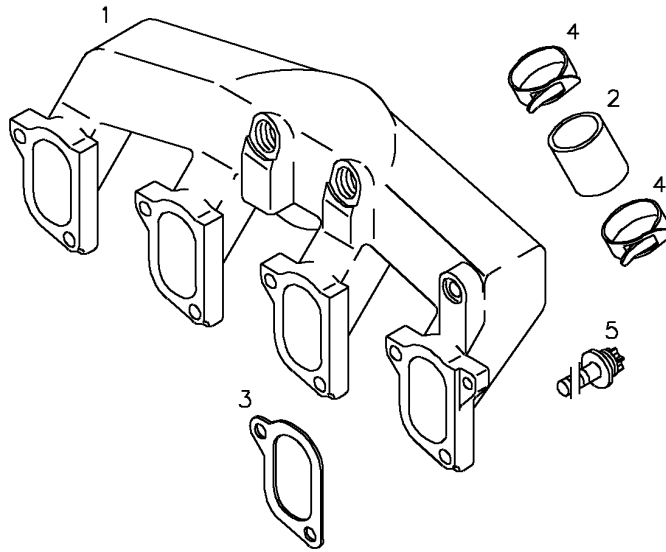

Pos	Teile -Nr.	Stk	Deutsch	English	Français	Espagnol	Nummer / Bemerkung / Note
001	0428 6403	001	SAUGROHR	SUCTION PIPE	TUYAU ASPIRATION	TUBO DE ASPIRACION	
002	0117 5634	001	GUMMIMUFFE	RUBBER SLEEVE	MANCHON CAOUTCHO	MANGUITO DE GOMA	
003	0417 9751	004	DICHTUNG	GASKET	GARNITURE/JOINT	JUNTA	
004	0117 8747	002	FEDERBANDSCHELLE	SPRING BAND CLAMP	COLLIER FEUILLARD	ABRAZADERA	
005	0118 1423	008	TORX-SCHRAUBE	TORX-HEAD BOLT	VIS A TETE TORX	TORNILLO TEST.TORX	

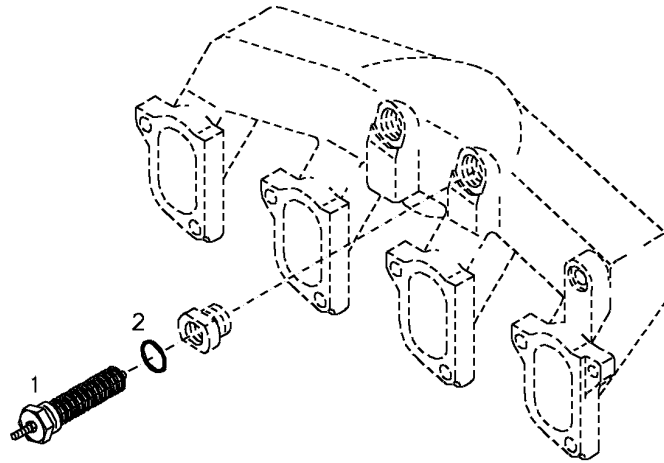

Pos	Teile -Nr.	Stk	Deutsch	English	Francais	Espagnol	Nummer / Bemerkung / Note
001	0117 9016	001	GLUEHWENDELKERZE	GLOW PLUG	BOUGIE INCANDESC.	BUJIA D. INCANDESC.	
002	0111 8737	001	DICHTRING	SEALINGRING	BAGUE D'ETANCHEITE	JUNTA ANULAR	

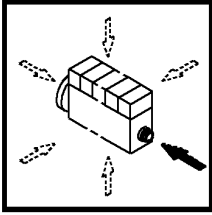

002 ©

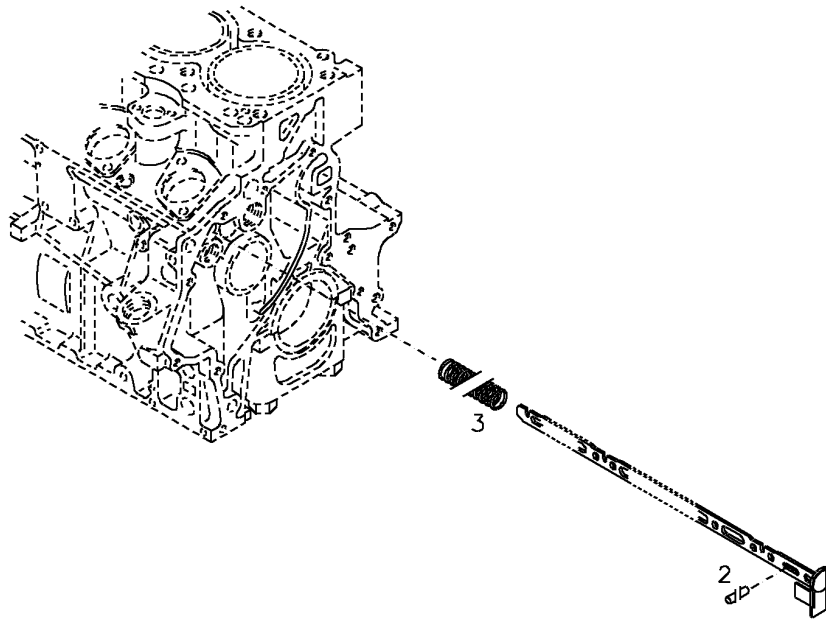

Pos	Teile -Nr.	Stk	Deutsch	English	Francais	Espagnol	Nummer / Bemerkung / Note
001	0417 9809	001	REGELSTANGE	CONTROL ROD	TIGE DE REGLAGE	BARRA D.REGULACION	
002	0417 6057	001	FIXIERSTIFT	LOCATING PIN	GOUPILLE DE FIXAT.	PASADOR D.FIJACION	
003	0417 0886	001	DRUCKFEDER	COMPRESSION SPRING	RESSORT DE PRESS.	RESORTE DE PRESION	

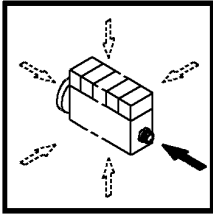

000 ©

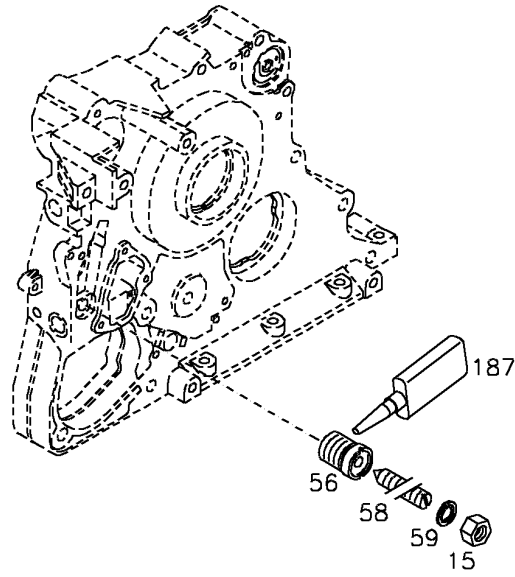

Pos	Teile -Nr.	Stk	Deutsch	English	Francais	Espagnol	Nummer / Bemerkung / Note
015	0114 8122	001	SECHSKANTMUTTER	HEXAGON NUT	ECROU HEXAGONAL	TUERCA EXAGONAL	
056	0417 4892	001	GEWINDEBUCHSE	SCREWED BUSH	DOUILLE FILETEE	CASQUILLO ROSCADO	
058	0114 8123	001	GEWINDESTIFT	SET SCREW	VIS SANS TETE	TORNILL SIN CABEZA	
059	0117 8666	001	DICHTRING	SEALINGRING	BAGUE D'ETANCHEITE	JUNTA ANULAR	
187	0101 6123	001	SICHERUNGSMITTEL	SAFETY/LOCK AGENT	RESINE-FREIN	MEDIO AFIANZADOR	

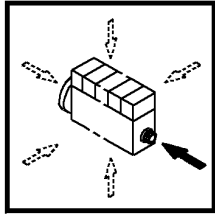

000 ©

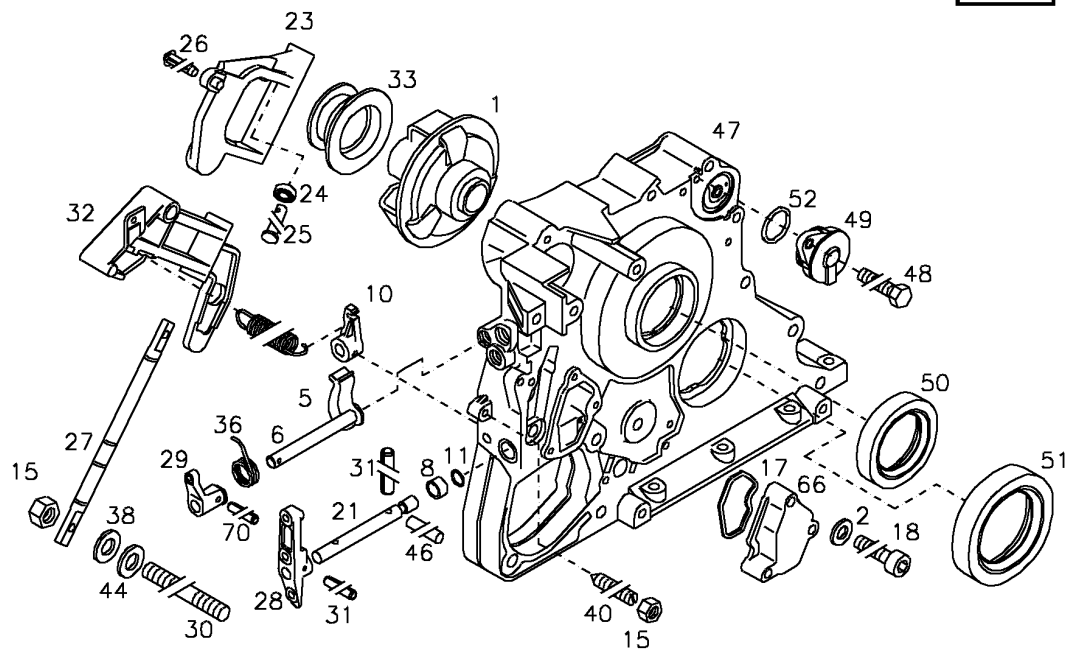

Pos	Teile -Nr.	Stk	Deutsch	English	Français	Espagnol	Nummer / Bemerkung / Note
001	0428 6243	001	MESSWERK	METERING UNIT	ELEMENT DE MESURE	MECANIS.MEDICION	
002	0110 7095	003	SCHEIBE	PLAIN WASHER	RONDELLE PLATE	ARANDELA PLANA	
005	0427 2765	001	ZUGFEDER	TENSION SPRING	RESSORT D.TRACTION	RESORTE D.TRACCION	
006	0428 6120	001	HEBELWELLE	LEVER SHAFT	ARBRE DE LEVIER	EJE DE PALANCA	
008	0417 5629	003	HUELSE	SLEEVE	DOUILLE	CASQUILLO	
010	0417 5945	001	HEBEL	LEVER/ARM	LEVIER	PALANCA	
011	0118 0080	002	RUNDDICHTRING	O-SEAL	ANNEAU TORIQUE	JUNTA TORNICA	
015	0114 8122	004	SECHSKANTMUTTER	HEXAGON NUT	ECROU HEXAGONAL	TUERCA EXAGONAL	
017	0417 8839	001	PROFILDICHTUNG	PROFILE WASHER	JOINT PROFILE	JUNTA PERFILADA	
018	0117 9835	003	ZYLINDERSCHRAUBE	CHEESE HEAD SCREW	VIS TETE CYLINDR.	TORN. CABEZA CIL.	
021	0428 0156	001	REGELHEBELWELLE	LEVER SHAFT	ARBRE LEVIER REGL	EJE PALNCA REGULAC	
023	0417 8261	001	ROLLENHEBEL	ROLLER LEVER	LEVIER A ROULEAU	PALANCA DE RODILLO	
024	0113 7646	002	RILLENKUGELLAGER	BALL BEARING	ROULEM. A BILLES	RODAMIENTO D.BOLAS	
025	0118 0059	002	BOLZEN	CLEVIS PIN	AXE D'ARTICULATION	BULON	
026	0111 5316	001	KERBNAGEL	NOTCHED NAIL	GOUPILLE CRANTEE	CLAVIJA RANURADA	
027	0417 8202	001	ACHSE	AXLE	AXE	EJE	
028	0417 9754	001	HEBEL	LEVER/ARM	LEVIER	PALANCA	
029	0428 6057	001	HEBEL	CLUTCH LEVER	LEVIER D'EMBAYAGE	PALANCA ACOPLAMIE.	
030	0114 8543	002	STIFTSCHRAUBE	STUD	GOUJON	ESPARRAGO	
031	0111 5434	002	SPANNSTIFT	STRAIGHT PIN	GOUPILLE SERRAGE	PASADOR ELASTICO	
032	0428 6046	001	HEBEL	LEVER/ARM	LEVIER	PALANCA	
033	0427 0491	001	MUFFE	SLEEVE	MANCHON	MANGUITO	
036	0428 1898	001	DREHFEDER	TORSION SPRING	RESSORT DE TORSION	RESORTE DE TORSION	
038	0338 1013	003	SCHEIBE	PLAIN WASHER	RONDELLE PLATE	ARANDELA PLANA	
040	0115 1181	001	GEWINDESTIFT	SET SCREW	VIS SANS TETE	TORNILL. SIN CABEZA	
044	0121 9780	002	SCHEIBE	PLAIN WASHER	RONDELLE PLATE	ARANDELA PLANA	
046	0110 5091	001	ZYLINDERSTIFT	PARALLEL PIN	GOUPILLE CYLINDR.	PASADOR CILINDRICO	
047	0428 1188	001	VORDERER-DECKEL	FRONT COVER	COUVERCLE AV	TAPA DELANTERA	
048	0114 3874	001	SECHSKANTSCHRAUBE	HEXAGON BOLT	VIS TETE HEXAGONAL	TORN. DE CABE. EXAG.	
049	0417 8572	001	ENTLUEFTUNGSVENTIL	BREATHER VALVE	SOUP DEGAGEMENT D'AIR	VALVULA DESAIREAC.	
050	0417 5435	001	RAD.WELL.DICHTRING	ROT.SHAFT LIP SEAL	JOINT A LEVRE	ANILLO D. JUNTA RAD	
051	0417 5434	001	RAD.WELL.DICHTRING	ROT.SHAFT LIP SEAL	JOINT A LEVRE	ANILLO D. JUNTA RAD	
052	0118 1784	001	RUNDDICHTRING	O-SEAL	ANNEAU TORIQUE	JUNTA TORNICA	
053	0210 8929	001	ANSCHLAGBOLZEN	STOP PIN	COUJON D'ARRET	BULON DE TOPE	

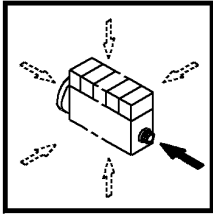

000 ©

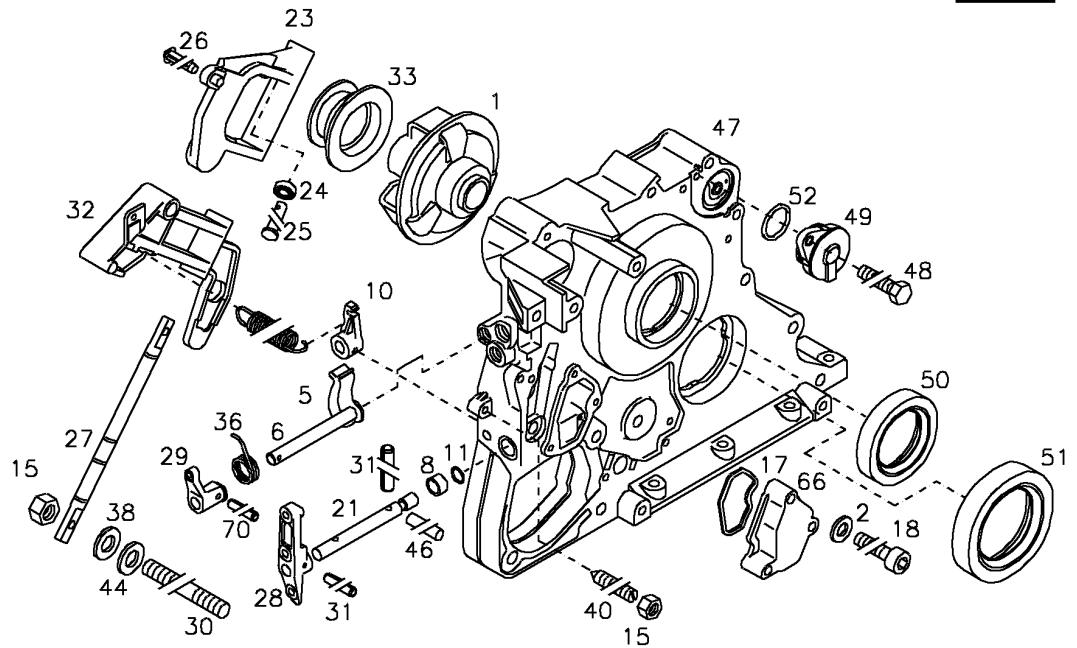

Pos	Teile -Nr.	Stk	Deutsch	English	Francais	Espagnol	Nummer / Bemerkung / Note
054	0427 0364	001	DRUCKFEDER	COMPRESSION SPRING	RESSORT DE PRESS.	RESORTE DE PRESION	
055	0110 7711	001	SICHERUNGSRING	CIRCLIP	CIRCLIP	ANILLO D. SEGURIDAD	
066	0417 8895	001	DECKEL	COVER	COUVERCLE	TAPA	
070	0112 5637	001	SPANNSTIFT	STRAIGHT PIN	GOUPILLE SERRAGE	PASADOR ELASTICO	
075	0428 1196	001	DRUCKFEDER	COMPRESSION SPRING	RESSORT DE PRESS.	RESORTE DE PRESION	
076	0428 1195	001	DRUCKSTEMPEL				
077	0117 9631	001	SCHEIBE	PLAIN WASHER	RONDELLE PLATE	ARANDELA PLANA	
079	0428 1218	001	SECHSKANTMUTTER	HEXAGON NUT	ECROU HEXAGONAL	TUERCA EXAGONAL	
080	0428 1298	001	SICHERUNGSSCHEIBE	RETAINING WASHER	BAGUE DE FREIN	ARANDELA SEGURIDAD	
081	0427 0463	001	HUBMAGNET	SOLENOID	ELECTRO-AIM LEVAGE	ELECTROIMAN	
082	0121 5850	001	SCHEIBE	PLAIN WASHER	RONDELLE PLATE	ARANDELA PLANA	
083	0121 0161	001	RUNDDICHTRING	O-SEAL	ANNEAU TORIQUE	JUNTA TORNICA	
084	0428 6159	001	UMLENKHEBEL	REVERSING LEVER	LEVIER DE RENVOI	PALANCA INVERSION	
085	0118 2249	001	HALBMONDRING	HALF-MOON RING	BAGUE DEMI LUNE	ANILLO MEDIA LUNA	

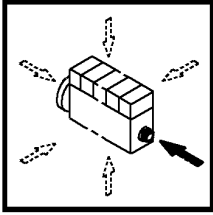

000 ©

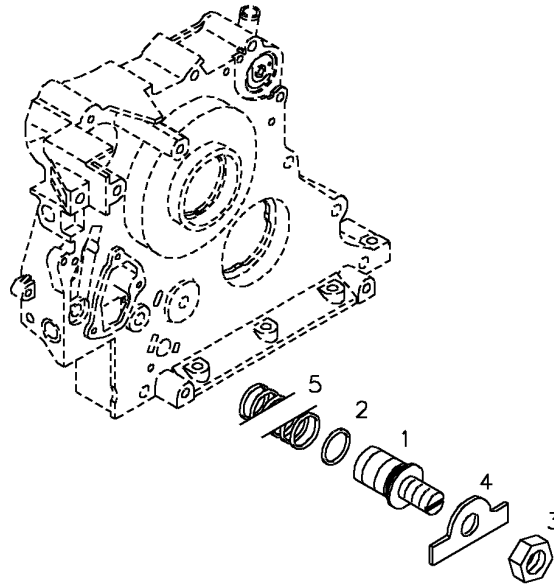

Pos	Teile -Nr.	Stk	Deutsch	English	Francais	Espagnol	Nummer / Bemerkung / Note
001	0417 4827	001	KAPSEL	CAPSULE	CAPSULE	CAPSULA	
002	0117 8672	001	RUNDDICHTRING	O-SEAL	ANNEAU TORIQUE	JUNTA TORNICA	
003	0111 4357	001	SECHSKANTMUTTER	HEXAGON NUT	ECROU HEXAGONAL	TUERCA EXAGONAL	
004	0417 5391	001	SCHEIBE	PLAIN WASHER	RONDELLE PLATE	ARANDELA PLANA	
005	0428 6355	001	DRUCKFEDER	COMPRESSION SPRING	RESSORT DE PRESS.	RESORTE DE PRESION	

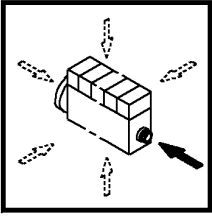

000 ©

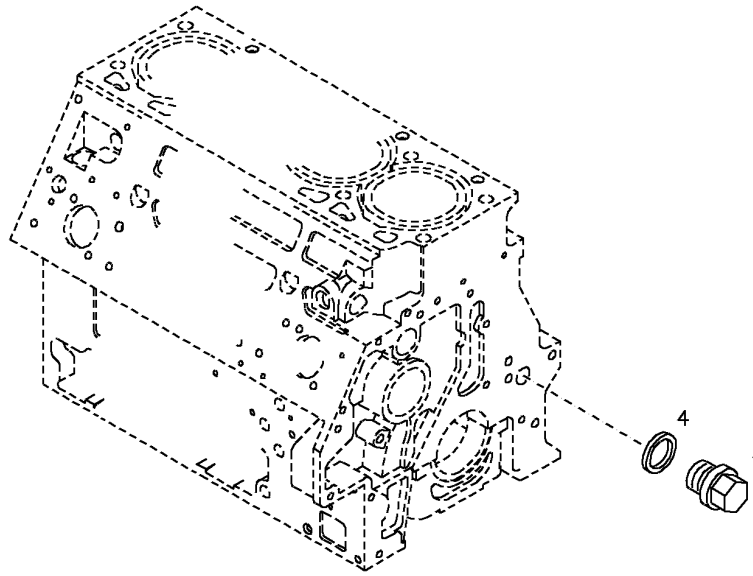

Pos	Teile -Nr.	Stk	Deutsch	English	Français	Espagnol	Nummer / Bemerkung / Note
001	0113 3631	001	VERSCHLUSSSCHRAUB	SCREW PLUG	BOUCHON FILETE	TAPON ROSCADO	
004	0111 8718	001	DICHTRING	SEALINGRING	BAGUE D'ETANCHEITE	JUNTA ANULAR	

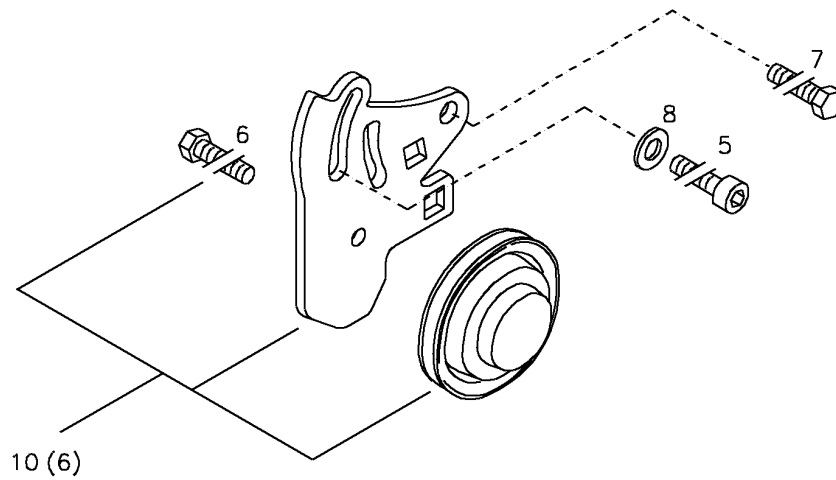

Pos	Teile -Nr.	Stk	Deutsch	English	Francais	Espagnol	Nummer / Bemerkung / Note
005	0111 0658	001	ZYLINDERSCHRAUBE	CHEESE HEAD SCREW	VIS TETE CYLINDR.	TORN. CABEZA CIL.	
006	0113 7083	001	SECHSKANTSCHRAUBE	HEXAGON BOLT	VIS TETE HEXAGONAL	TORN.DE CABE.EXAG.	
007	0111 2418	001	SECHSKANTSCHRAUBE	HEXAGON BOLT	VIS TETE HEXAGONAL	TORN.DE CABE.EXAG.	
008	0121 6110	001	SCHEIBE	PLAIN WASHER	RONDELLE PLATE	ARANDELA PLANA	
010	0417 5031	001	SPANNROLLE	TENSIONING PULLEY	POULIE DE TENSION	POLEA TENSORA	MIT POS.... WITH ITEM.... CON POS. AVEC POSTE.... (6)



SCHMALKEILRIEMEN
NARROW V-BELT
COURR TRAP ETROITE
CORR.TRAPEC.ESTREC

39 - 0506 3354

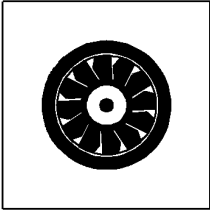

001 ©

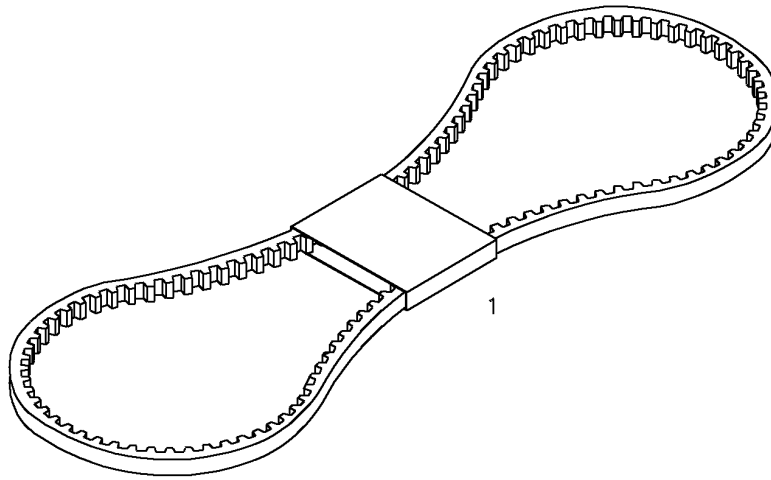

Pos	Teile -Nr.	Stk	Deutsch	English	Francais	Espagnol	Nummer / Bemerkung / Note
001	0117 9564	001	SCHMALKEILRIEMEN	NARROW V-BELT	COURR TRAP ETROITE	CORR.TRAPEC.ESTREC	

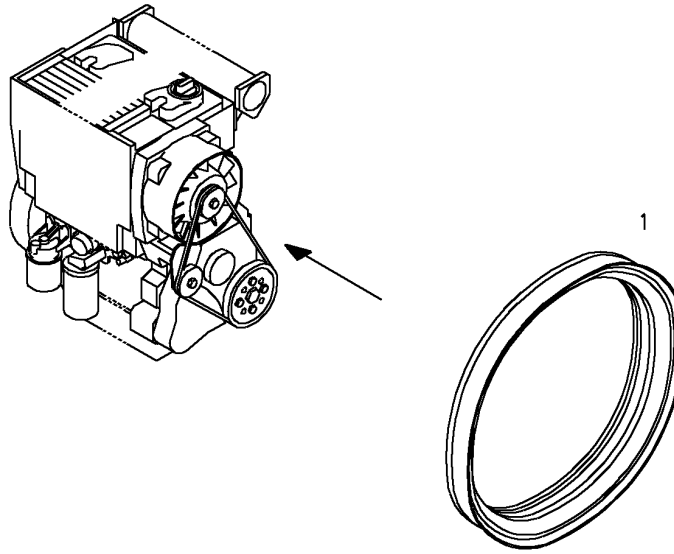

Pos	Teile -Nr.	Stk	Deutsch	English	Francais	Espagnol	Nummer / Bemerkung / Note
001	0417 6380	001	DICHTPROFIL	SEALING SECTION	PROFIL D'ETANCH	PERFIL HERMETIZAN.	

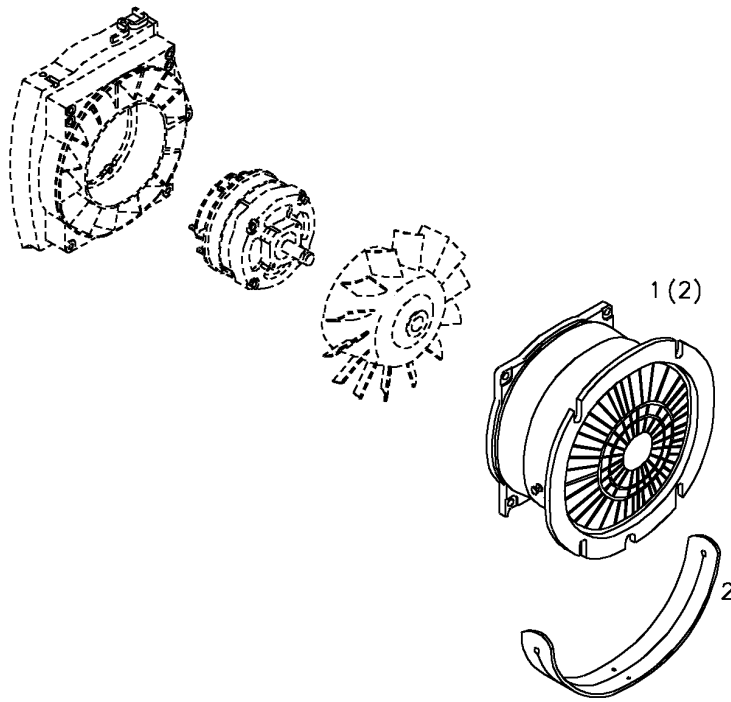

Pos	Teile -Nr.	Stk	Deutsch	English	Francais	Espagnol	Nummer / Bemerkung / Note
001	0427 0055	001	GEBLAESEMANTEL	BLOWER JACKET	ENVELOPPE SOUFFLTE	ENVOLVENT.SOPLANTE	MIT POS.... WITH ITEM.... CON POS. AVEC POSTE.... (2)
002	0427 0729	001	FLACHDICHTUNG	FLAT GASKET	GARNITURE PLATE	JUNTA PLANA	

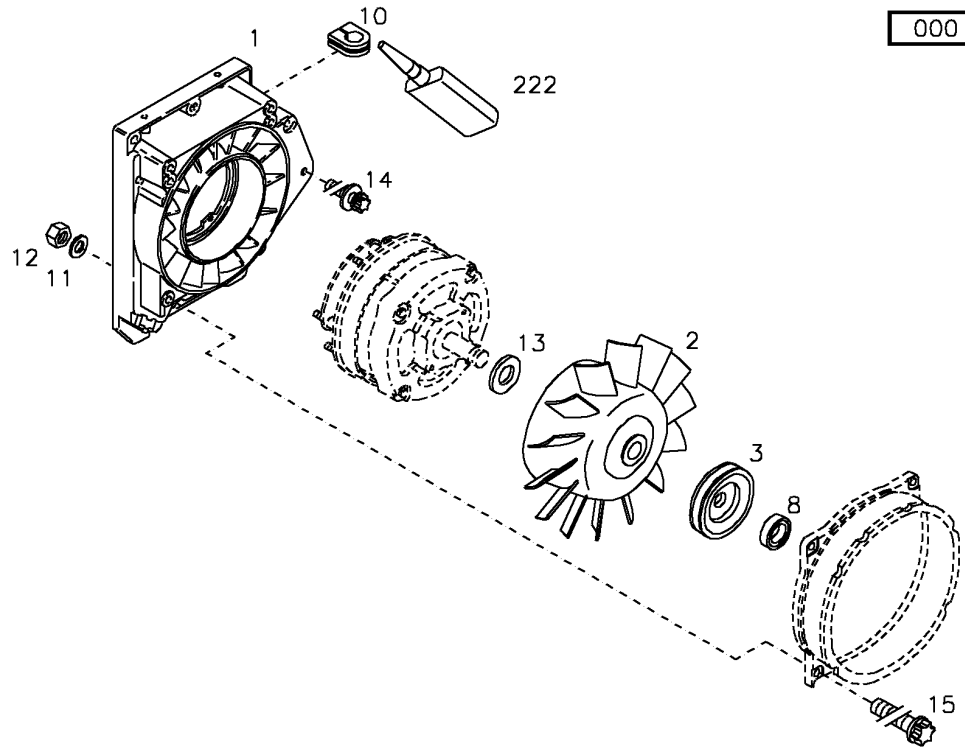
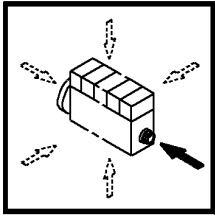

000 ©

Pos	Teile -Nr.	Stk	Deutsch	English	Francais	Espagnol	Nummer / Bemerkung / Note
001	0428 6644	001	GEBLAESEMANTEL	BLOWER JACKET	ENVELOPPE SOUFFLTE	ENVOLVENT.SOPLANTE	
002	0427 0940	001	LAUFRAD	IMPELLER	ROUE A AUBES/ROTOR	ROTOR	
003	0417 6260	001	KEILRIEMENSCHLEIFE	V-GROOVED PULLEY	POULIE A GORGE	POLEA TRAPEZIAL	
008	0417 6261	001	SCHEIBE	PLAIN WASHER	RONDELLE PLATE	ARANDELA PLANA	
010	0417 3918	002	GUMMIMUFFE	RUBBER SLEEVE	MANCHON EN CAOUTC	MANGUITO DE CAUCHO	
011	0114 4510	004	SCHEIBE	PLAIN WASHER	RONDELLE PLATE	ARANDELA PLANA	
012	0111 2803	004	SECHSKANTMUTTER	HEXAGON NUT	ECROU HEXAGONAL	TUERCA EXAGONAL	
013	0210 8690	001	SCHEIBE	PLAIN WASHER	RONDELLE PLATE	ARANDELA PLANAMM DICKMM THICKNESS ESPESOR:.....MMMM D'EPAISSEUR 5,5 MM
014	0117 7369	003	TORX-SCHRAUBE	TORX-HEAD BOLT	VIS A TETE TORX	TORNILLO TEST.TORX	
015	0118 0228	004	TORX-SCHRAUBE	TORX-HEAD BOLT	VIS A TETE TORX	TORNILLO TEST.TORX	
222	0101 6121	001	KLEBSTOFF	ADHESIVE	ADHESIF	PEGAMENTO	
950	0210 8691	001	SCHEIBE	PLAIN WASHER	RONDELLE PLATE	ARANDELA PLANAMM DICKMM THICKNESS ESPESOR:.....MMMM D'EPAISSEUR 6,0 MM
951	0210 8526	001	SCHEIBE	PLAIN WASHER	RONDELLE PLATE	ARANDELA PLANAMM DICKMM THICKNESS ESPESOR:.....MMMM D'EPAISSEUR 6,5 MM
952	0210 8527	001	SCHEIBE	PLAIN WASHER	RONDELLE PLATE	ARANDELA PLANAMM DICKMM THICKNESS ESPESOR:.....MMMM D'EPAISSEUR 7,0 MM
953	0210 9563	001	SCHEIBE	PLAIN WASHER	RONDELLE PLATE	ARANDELA PLANAMM DICKMM THICKNESS ESPESOR:.....MMMM D'EPAISSEUR



KUEHLGEBLAESE
COOLING FAN
SOUFFLANTE REFROID
VENTILADOR

39 - 0507 9237

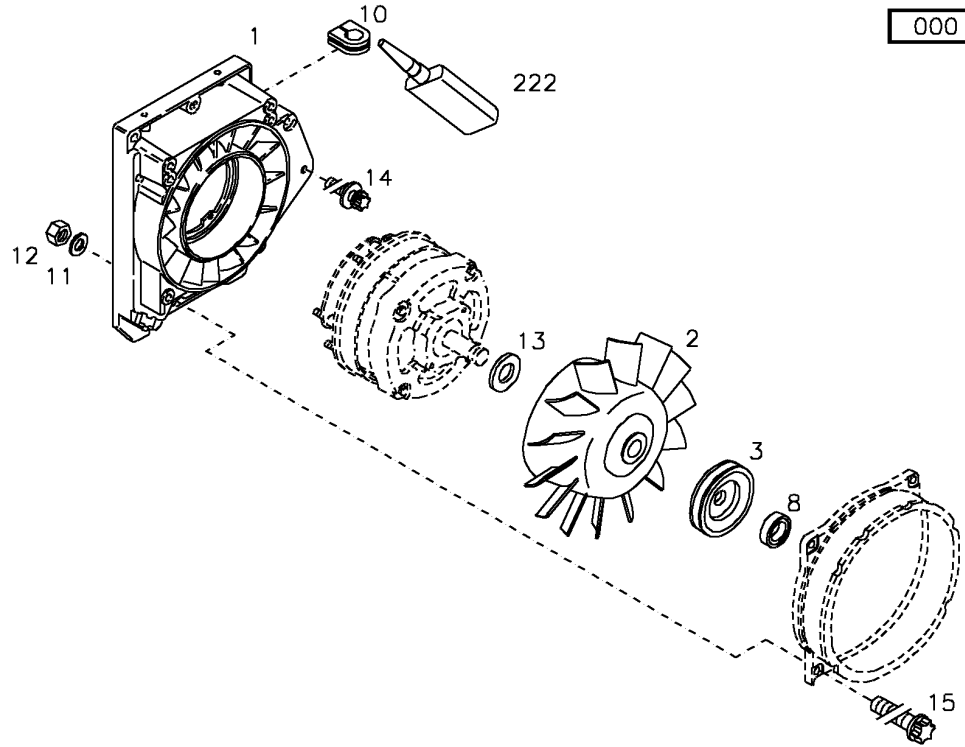
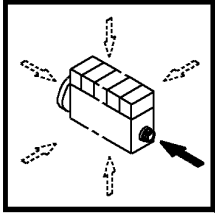

000 ©

Pos	Teile -Nr.	Stk	Deutsch	English	Francais	Espagnol	Nummer / Bemerkung / Note
953	0210 9563	001	SCHEIBE	PLAIN WASHER	RONDELLE PLATE	ARANDELA PLANA	5,0MM

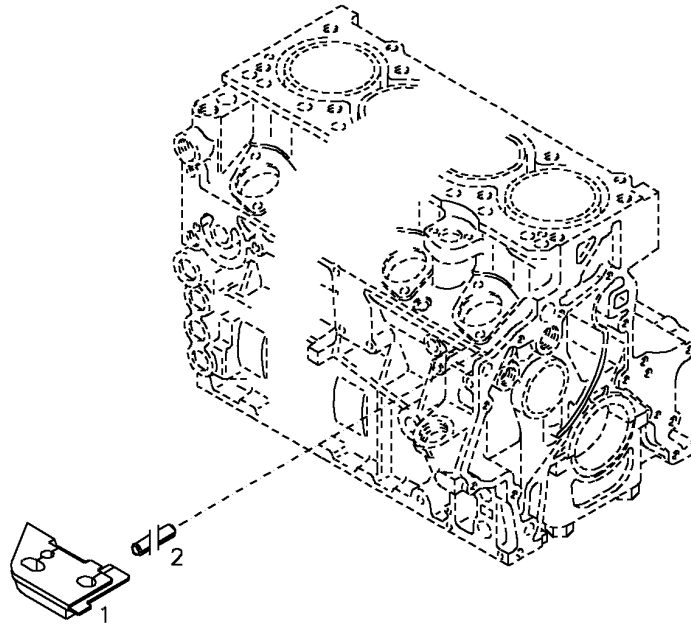

Pos	Teile -Nr.	Stk	Deutsch	English	Francais	Espagnol	Nummer / Bemerkung / Note
001	0417 8358	001	PROFILGUMMI	SECTIONAL RUBBER	PROFILE CAOUTCHOUC	PERFIL DE GOMA	
002	0111 5426	002	SPANNSTIFT	STRAIGHT PIN	GOUILLE SERRAGE	PASADOR ELASTICO	

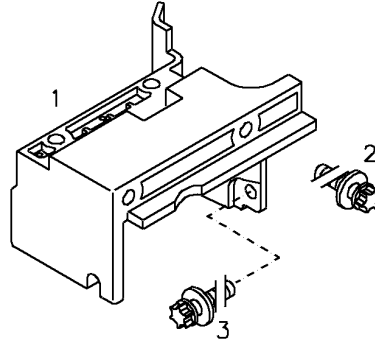

Pos	Teile -Nr.	Stk	Deutsch	English	Francais	Espagnol	Nummer / Bemerkung / Note
001	0427 0292	001	LUFTFUEHRUNG	AIR GUIDANCE	CONDUITE D'AIR	CONDUCTO DE AIRE	
002	0117 7369	002	TORX-SCHRAUBE	TORX-HEAD BOLT	VIS A TETE TORX	TORNILLO TEST.TORX	
003	0118 1426	001	TORX-SCHRAUBE	TORX-HEAD BOLT	VIS A TETE TORX	TORNILLO TEST.TORX	

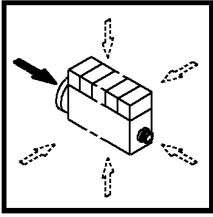

000 ©

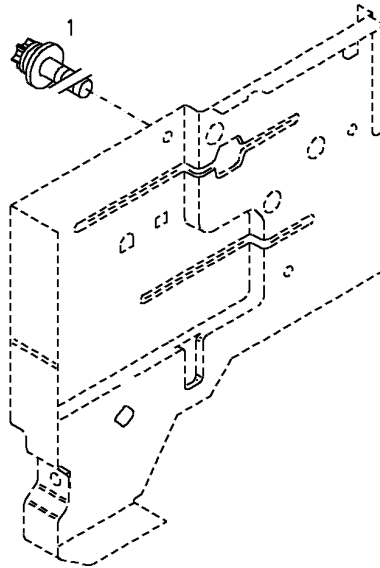

Pos	Teile -Nr.	Stk	Deutsch	English	Francais	Espagnol	Nummer / Bemerkung / Note
001	0117 9622	003	TORX-SCHRAUBE	TORX-HEAD BOLT	VIS A TETE TORX	TORNILLO TEST.TORX	

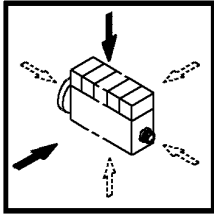

000 ©

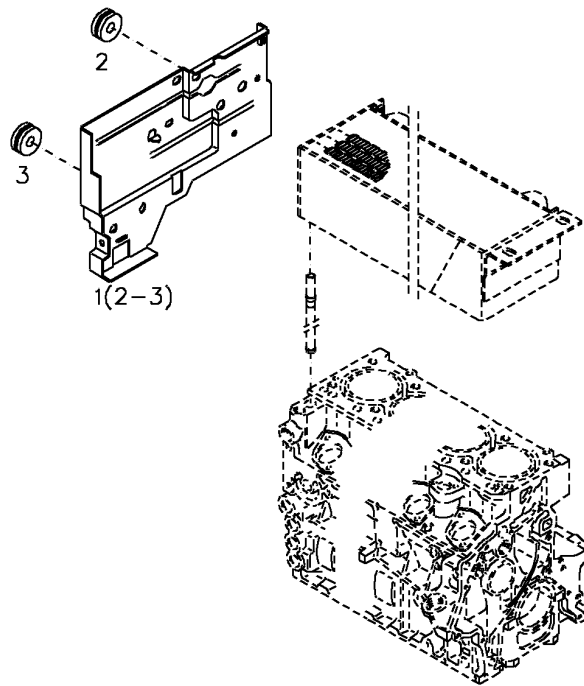

Pos	Teile -Nr.	Stk	Deutsch	English	Francais	Espagnol	Nummer / Bemerkung / Note
001	0428 6503	001	STANDBLECH	AIR DUCT REAR WALL	TOLE VERTICALE	CHAPA VERTICAL	MIT POS.... WITH ITEM.... CON POS AVEC POSTE.... (2-3)
002	0116 7425	001	GUMMITUELLE	RUBBER GROMMET	MANCHON CAOUTCHO	FUNDA DE GOMA	
003	0116 7428	001	GUMMITUELLE	RUBBER GROMMET	MANCHON CAOUTCHO	FUNDA DE GOMA	



HAUBE
COOLING AIRDUCT
TUYAUTERIE D'AIR
GUIA AIRE REFRIGE.

40 - 0507 9156

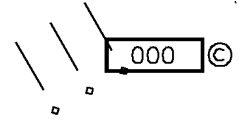

Nicht freigegeben

Pos	Teile -Nr.	Stk	Deutsch	English	Français	Espagnol	Nummer / Bemerkung / Note
001	0428 6391	001	HAUBE	COOLING AIRDUCT	TUYAUTERIE D'AIR	GUIA AIRE REFRIGE.	

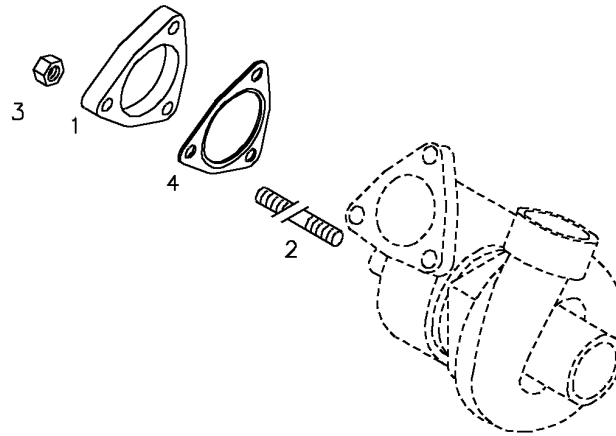

Pos	Teile -Nr.	Stk	Deutsch	English	Francais	Espagnol	Nummer / Bemerkung / Note
001	0417 2490	001	FLANSCH	FLANGE	BRIDE/COLLET	BRIDA	
002	0115 3346	003	STIFTSCHRAUBE	STUD	GOUJON	ESPARRAGO	
003	0112 2477	003	SECHSKANTMUTTER	HEXAGON NUT	ECROU HEXAGONAL	TUERCA EXAGONAL	
004	0417 2446	001	DICHTUNG	GASKET	GARNITURE/JOINT	JUNTA	

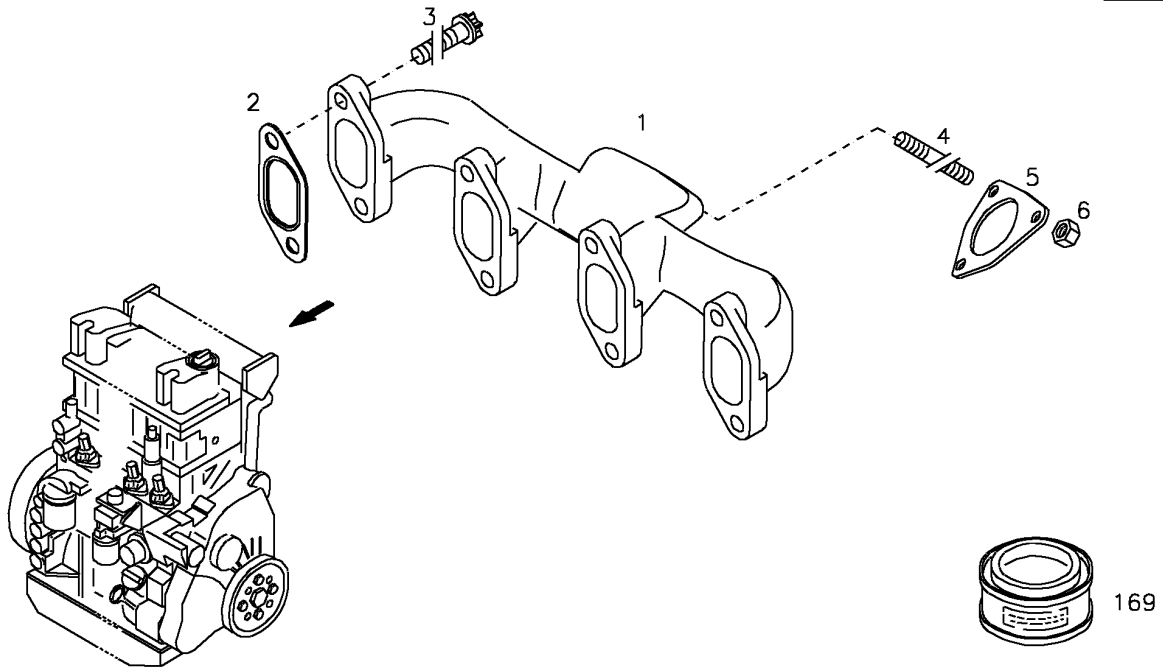

Pos	Teile -Nr.	Stk	Deutsch	English	Francais	Espagnol	Nummer / Bemerkung / Note
001	0427 1176	001	ABGASSAMMELROHR	EXHAUST MANIFOLD	COLLECT.D'ECHAPPEM	COLECTOR DE ESCAPE	
002	0417 3862	004	DICHTUNG	GASKET	GARNITURE/JOINT	JUNTA	
003	0118 1006	008	TORX-SCHRAUBE	TORX-HEAD BOLT	VIS A TETE TORX	TORNILLO TEST.TORX	
004	0115 3347	003	STIFTSCHRAUBE	STUD	GOUJON	ESPARRAGO	
005	0417 4032	001	DICHTUNG	GASKET	GARNITURE/JOINT	JUNTA	
006	0113 8774	003	SECHSKANTMUTTER	HEXAGON NUT	ECROU HEXAGONAL	TUERCA EXAGONAL	
169	0101 6116	001	MONTAGEMITTEL	FITTING COMPOUND	MOYENS DE MONTAGE	MEDIO DE MONTAJE	



ABGASTURBOLADER
TURBOCHARGER
TURBOCOMPRESSEUR
TURBO

43 - 0507 9011

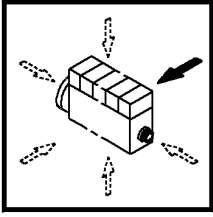

000 ©

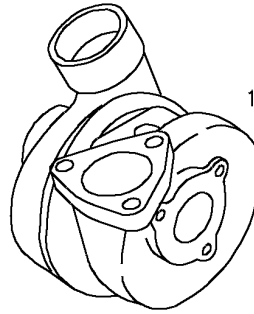

Pos	Teile -Nr.	Stk	Deutsch	English	Francais	Espagnol	Nummer / Bemerkung / Note
001	0428 1437	001	ABGASTURBOLADER	TURBOCHARGER	TURBOCOMPRESSEUR	TURBO	

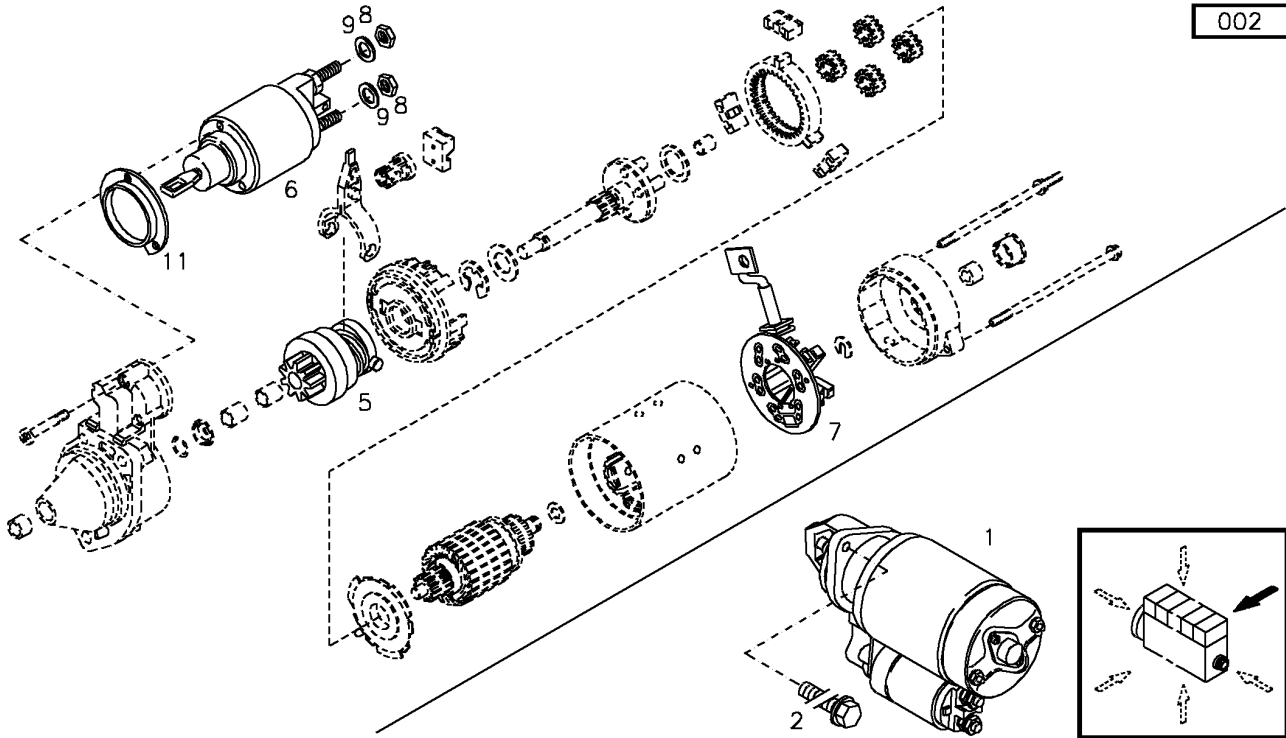

Pos	Teile -Nr.	Stk	Deutsch	English	Francais	Espagnol	Nummer / Bemerkung / Note
001	0118 1751	001	STARTER	STARTER	DEMARREUR	ARRANCADOR	
002	0118 1390	002	SECHSKANTSCHRAUBE	HEXAGON BOLT	VIS TETE HEXAGONAL	TORN.DE CABE.EXAG.	
005	0134 0070	001	STARTERRITZEL	STARTER PINION	PIGNON D.DEMARREUR	PINON ARRANCADOR	
006	0131 9265	001	RELAIS	RELAY	RELAIS	RELE	
007	0131 9920	001	KOHLEBUERST.HALTER	BRUSH HOLDER	PORTE-BALAI CHARB	PORTAESCOBILLA	
008	0131 8659	002	SECHSKANTMUTTER	HEXAGON NUT	ECROU HEXAGONAL	TUERCA EXAGONAL	
009	0132 0257	002	FEDERSCHEIBE	SPRING WASHER	RONDELLE ELASTIQUE	ARANDELA ELASTICA	
011	0131 9761	001	ABDECKSCHEIBE	COVERING PLATE	RONDELLA	DISCO PROTECTOR	

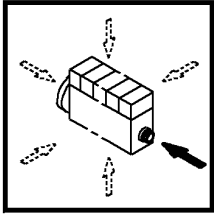

000 ©

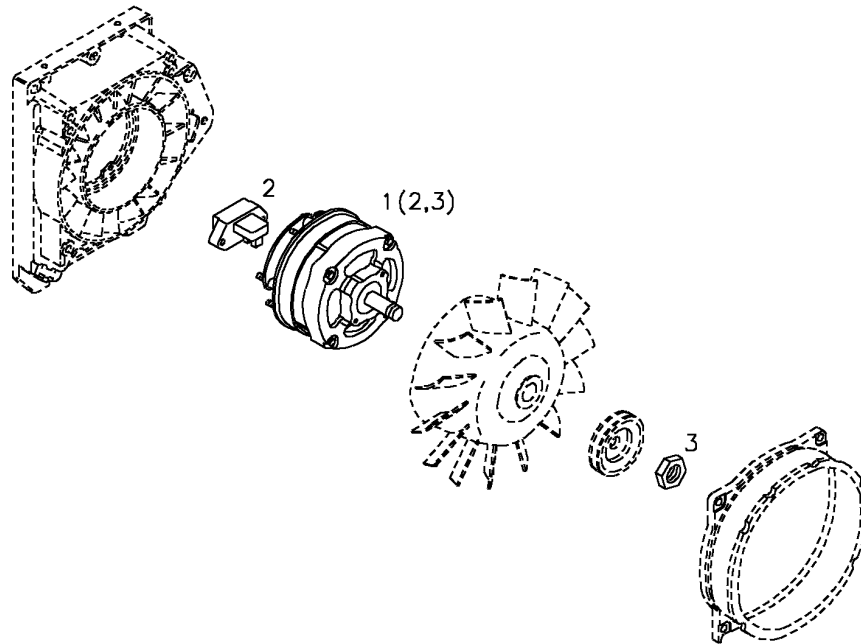

Pos	Teile -Nr.	Stk	Deutsch	English	Français	Espagnol	Nummer / Bemerkung / Note
001	0118 2107	001	GENERATOR	GENERATOR	GENERATRICE	GENERADOR	MIT POS.... WITH ITEM.... CON POS. AVEC POSTE.... (2,3)
002	0118 0751	001	SPANNUNGSREGLER	VOLTAGE REGULATOR	REGULATEUR TENSION	REGULADOR VOLTAJE	
003	0113 1115	001	SECHSKANTMUTTER	HEXAGON NUT	ECROU HEXAGONAL	TUERCA EXAGONAL	

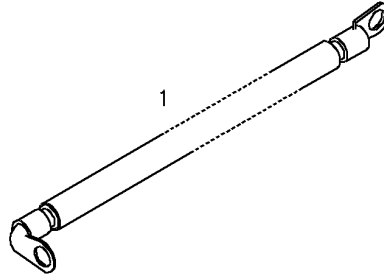

Pos	Teile -Nr.	Stk	Deutsch	English	Français	Espagnol	Nummer / Bemerkung / Note
001	0417 9131	001	LEITUNG	LINE	FIL ELECTRIQUE	LINEA	LANG LONG LARGO LONG (UE) (S) 740 MM

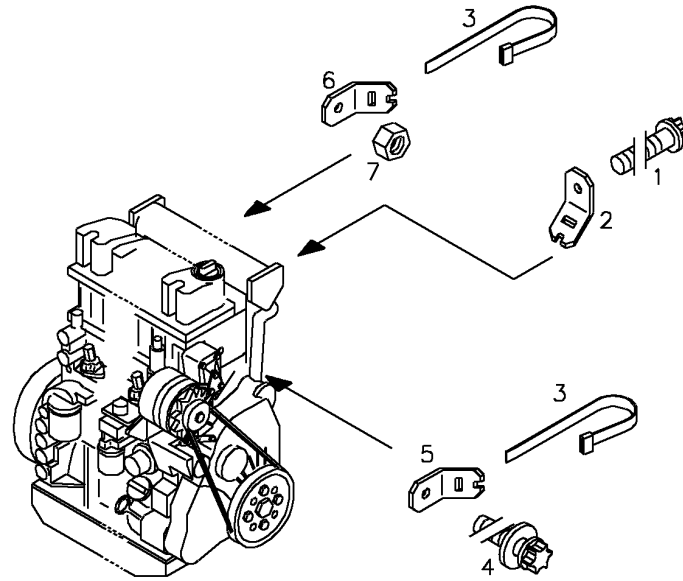

Pos	Teile -Nr.	Stk	Deutsch	English	Francais	Espagnol	Nummer / Bemerkung / Note
001	0117 9598	001	TORX-SCHRAUBE	TORX-HEAD BOLT	VIS A TETE TORX	TORNILLO TEST.TORX	
002	0419 0904	001	HALTER	BRACKET	SUPPORT/PORTEQUTIL	SOPORTE	
003	0117 6435	003	HALTEBAND	CLAMPING BAND	BANDE DE SERRAGE	FLEJE DE SUJECION	
004	0118 1420	001	TORX-SCHRAUBE	TORX-HEAD BOLT	VIS A TETE TORX	TORNILLO TEST.TORX	
005	0224 9331	001	HALTER	BRACKET	SUPPORT/PORTEQUTIL	SOPORTE	
006	0419 9094	001	HALTER	BRACKET	SUPPORT/PORTEQUTIL	SOPORTE	
007	0114 8122	002	SECHSKANTMUTTER	HEXAGON NUT	ECROU HEXAGONAL	TUERCA EXAGONAL	

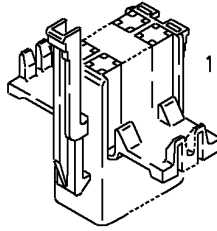

Pos	Teile -Nr.	Stk	Deutsch	English	Francais	Espagnol	Nummer / Bemerkung / Note
001	0417 8431	001	BUCHSENGEHAEUSE	BEARING HOUSING	LOGEMENT DU PALIER	CAJA SUPORTE	
002	0417 9711	010	BUCHSENKONTAKT	JACK	DOUILLE DE CONTACT	CASQUILLO HEMBRA	

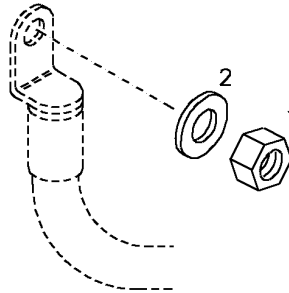

Pos	Teile -Nr.	Stk	Deutsch	English	Francais	Espagnol	Nummer / Bemerkung / Note
001	0111 2802	001	SECHSKANTMUTTER	HEXAGON NUT	ECROU HEXAGONAL	TUERCA EXAGONAL	
002	0114 4510	001	SCHEIBE	PLAIN WASHER	RONDELLE PLATE	ARANDELA PLANA	

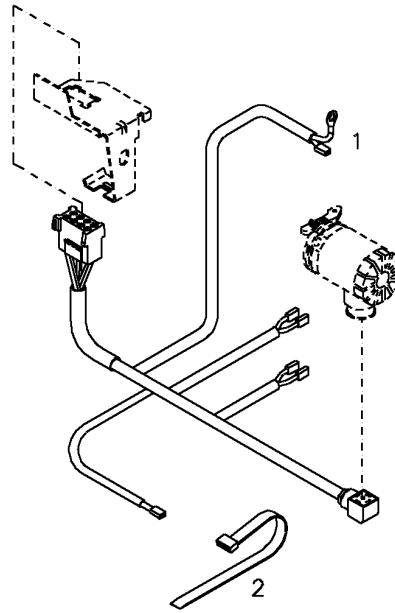
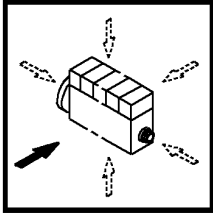

000 ©

Pos	Teile -Nr.	Stk	Deutsch	English	Francais	Espagnol	Nummer / Bemerkung / Note
001	0427 2968	001	KABELBAUM	CABLE HARNESS	FAISCEAU DE CABLES	HAZ DE CABLES	
002	0117 6435	001	HALTEBAND	CLAMPING BAND	BANDE DE SERRAGE	FLEJE DE SUJECION	

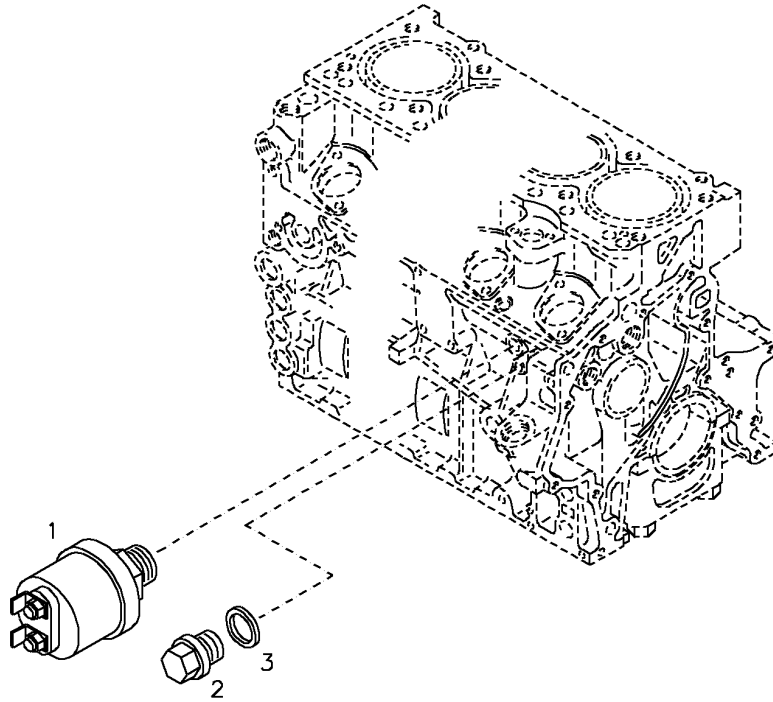

Pos	Teile -Nr.	Stk	Deutsch	English	Francais	Espagnol	Nummer / Bemerkung / Note
001	0117 5981	001	DRUCKGEBER	PRESSURE SENSOR	TRANSMETTEUR DE PR	TRANSMISOR PRESION	
002	0112 4445	001	VERSCHLUSSSCHRAUB	SCREW PLUG	BOUCHON FILETE	TAPON ROSCADO	
003	0115 1319	001	DICHTRING	SEALINGRING	BAGUE D'ETANCHEITE	JUNTA ANULAR	

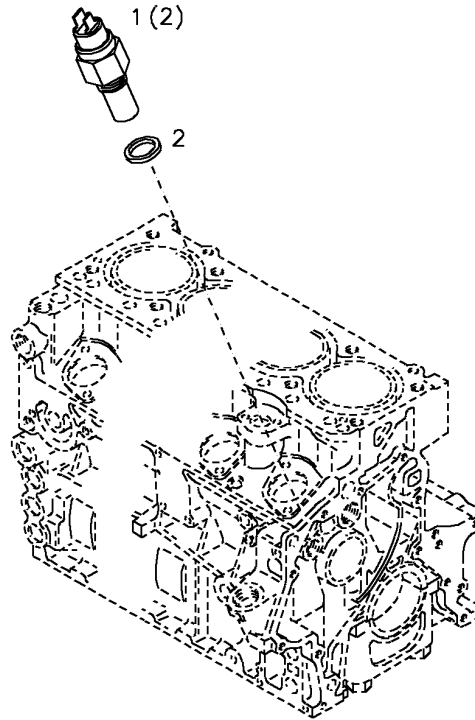

Pos	Teile -Nr.	Stk	Deutsch	English	Francais	Espagnol	Nummer / Bemerkung / Note
001	0118 0460	001	TEMPERATURGEBER	TEMPER. TRANSMITTER	SONDE THERMIQUE	SENSOR TEMPERATUR	MIT POS.... WITH ITEM.... CON POS. AVEC POSTE.... (2)
002	0114 3531	001	DICHTRING	SEALINGRING	BAGUE D'ETANCHEITE	JUNTA ANULAR	

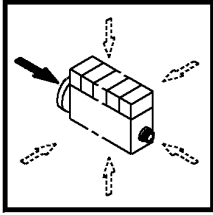

002 ©

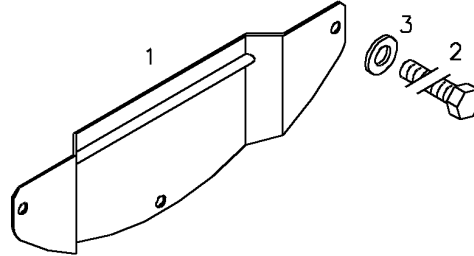

Pos	Teile -Nr.	Stk	Deutsch	English	Francais	Espagnol	Nummer / Bemerkung / Note
001	0417 2349	001	ABDECKBLECH	COVER PLATE	TOLE RECOUVREMENT	CHAPA DE CUBIERTA	
002	0111 2232	003	SECHSKANTSCHRAUBE	HEXAGON BOLT	VIS TETE HEXAGONAL	TORN.DE CABE.EXAG.	
003	0115 1016	003	SCHEIBE	PLAIN WASHER	RONDELLE PLATE	ARANDELA PLANA	

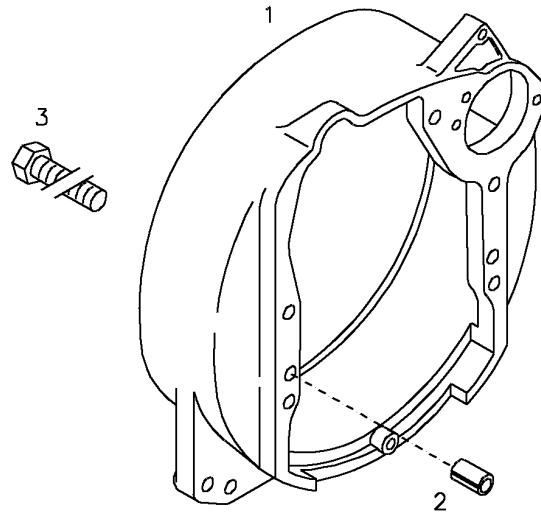

Pos	Teile -Nr.	Stk	Deutsch	English	Francais	Espagnol	Nummer / Bemerkung / Note
001	0427 0979	001	ZWISCHENGEHAEUSE	ADAPTER HOUSING	CARTER INTERMED.	CAJA INTERMEDIA	
002	0210 9066	002	SPANNBUCHSE	CLAMPING BUSH	DOUILLE DE SERRAGE	PASADOR ELASTICO	
003	0110 3341	004	SECHSKANTSCHRAUBE	HEXAGON BOLT	VIS TETE HEXAGONAL	TORN.DE CABE.EXAG.	

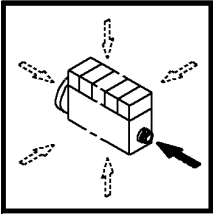

000 ©

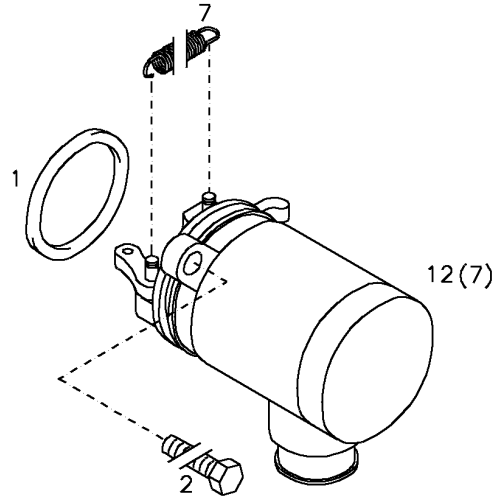

Pos	Teile -Nr.	Stk	Deutsch	English	Français	Espagnol	Nummer / Bemerkung / Note
001	0116 4748	001	RUNDDICHTRING	O-SEAL	ANNEAU TORIQUE	JUNTA TORNICA	
002	0114 8207	002	SECHSKANTSCHRAUBE	HEXAGON BOLT	VIS TETE HEXAGONAL	TORN.DE CABE.EXAG.	
007	0417 5724	001	ZUGFEDER	TENSION SPRING	RESSORT D.TRACTION	RESORTE D. TRACCION	
012	0427 2956	001	MOTORABSTELLUNG	SHUTDOWN DEVICE	ARRET DU MOTEUR	PARADA DEL MOTOR	MIT POS.... WITH ITEM.... CON POS. AVEC POSTE.... (7)

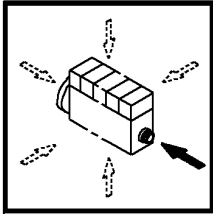

000 ©

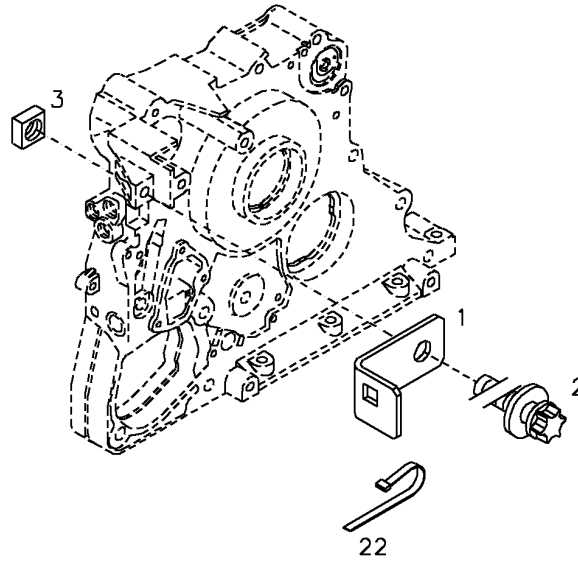

Pos	Teile -Nr.	Stk	Deutsch	English	Francais	Espagnol	Nummer / Bemerkung / Note
001	0427 2973	001	HALTER	BRACKET	SUPPORT/PORTEQUIL	SOPORTE	
002	0117 9622	001	TORX-SCHRAUBE	TORX-HEAD BOLT	VIS A TETE TORX	TORNILLO TEST.TORX	
003	0110 8080	001	VIERKANTMUTTER	SQUARE NUT	ECROU CARRE	TUERCA CUADRADA	
022	0117 6435	001	HALTEBAND	CLAMPING BAND	BANDE DE SERRAGE	FLEJE DE SUJECION	

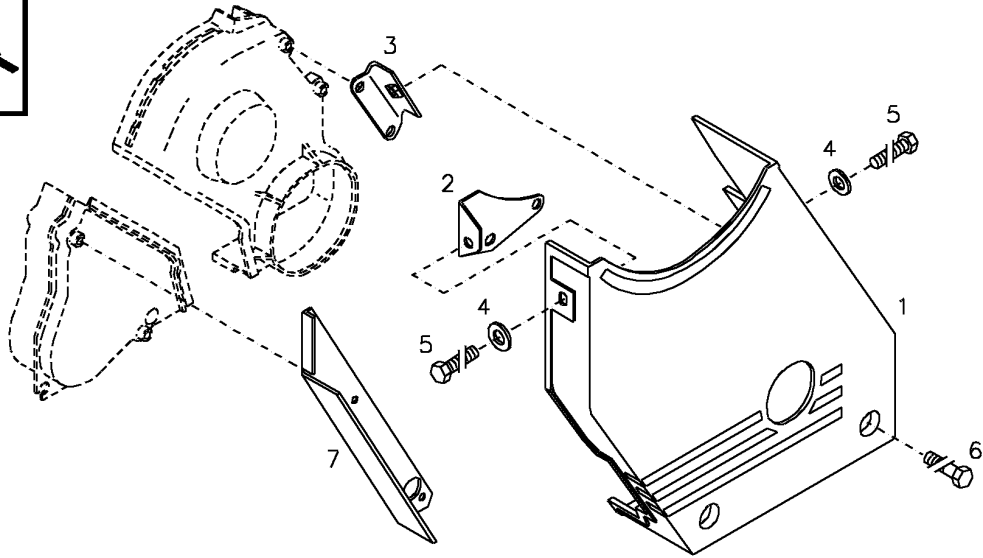
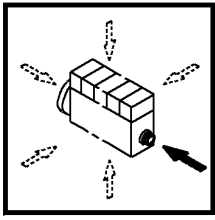

Pos	Teile -Nr.	Stk	Deutsch	English	Francais	Espagnol	Nummer / Bemerkung / Note
001	0417 6288	001	KEILRIEMENSCHUTZ	V-BELT GUARD	PROT COURR TRAPEZ	PROTECCION	
002	0417 2724	001	HALTER	BRACKET	SUPPORT/PORTEQUTIL	SOPORTE	
003	0428 0484	001	HALTER	BRACKET	SUPPORT/PORTEQUTIL	SOPORTE	
004	0417 2492	002	SCHEIBE	PLAIN WASHER	RONDELLE PLATE	ARANDELA PLANA	
005	0113 7083	002	SECHSKANTSCHRAUBE	HEXAGON BOLT	VIS TETE HEXAGONAL	TORN.DE CABE.EXAG.	
006	0111 1205	002	SECHSKANTSCHRAUBE	HEXAGON BOLT	VIS TETE HEXAGONAL	TORN.DE CABE.EXAG.	
007	0428 0483	001	ABDECKBLECH	COVER PLATE	TOLE RECOUVREMENT	CHAPA DE CUBIERTA	

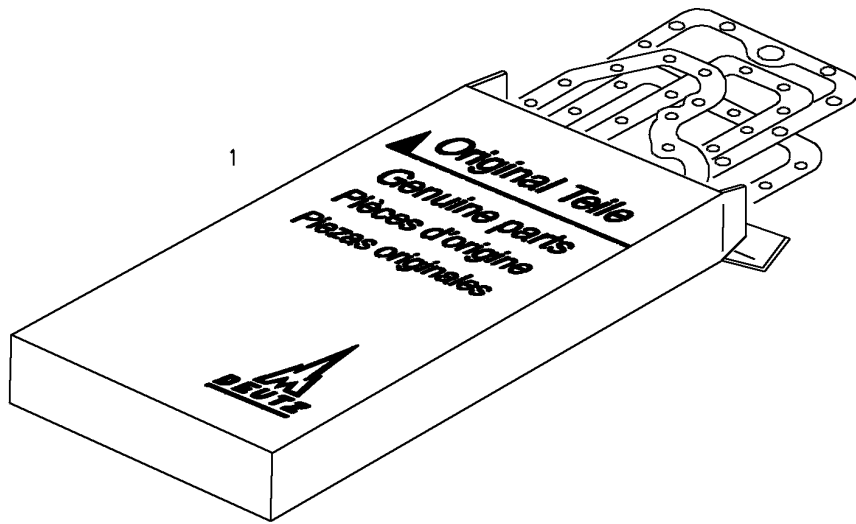

Pos	Teile -Nr.	Stk	Deutsch	English	Français	Espagnol	Nummer / Bemerkung / Note
001	0293 1141	001	ZUS.-DICHTUNGSSATZ	SUPPLEM.GASKET SET	JEU DE JOINTS AUX.	JUEGO JUNTAS COMPL	FUER KURBELGEH.-ENTLUEFTUNG IN DER ZYL.-KOPFHAUBE



DICHTUNGSSATZ
GASKET SET
JEU DE JOINTS
JUEGO DE JUNTAS

90 - 0507 7823

000 ©

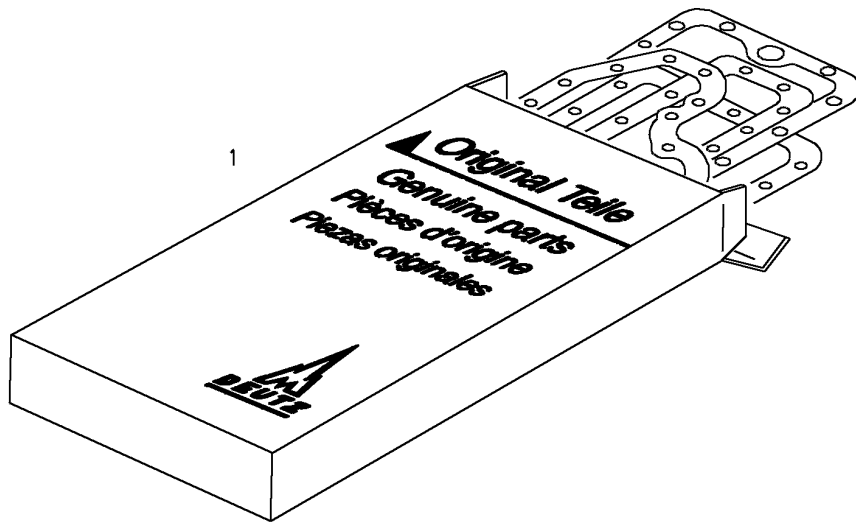

Pos	Teile -Nr.	Stk	Deutsch	English	Français	Espagnol	Nummer / Bemerkung / Note
001	0293 1435	001	DICHTUNGSSATZ	GASKET SET	JEU DE JOINTS	JUEGO DE JUNTAS	



Teileverwendung
Parts Cross Reference
Affectation des No. de Pieces
Asignacion de Nos de Piezas

Datum/Date/Fecha: 27.10.2004 Seite/Page/Pagina: 1 / 3

TN/PN No.P.	BG/CG	ETL	Pos/ Fig
01016024	16	05067625	234
01016102	02	05069057	244
01016116	41	05069183	169
01016121	39	05079237	222
01016122	01	05079188	181
	10	05079185	188
01016123	27	05077923	187
01016125	01	05079161	189
	08	05074211	189
01100483	16	05067624	003
01103341	52	05069152	003
01105091	27	05079062	046
01107095	27	05079062	002
01107711	27	05079062	055
01107727	11	05051930	001
01108080	56	05079139	003
01110422	01	05079161	028
01110433	17	05067639	001
01110658	39	05051119	005
01111080	10	05079021	001
01111205	57	05074297	006
01112232	52	05051756	002
01112418	39	05051119	007
01112802	48	05068273	001
01112803	39	05079237	012
01112824	17	05079205	002
01114357	27	05079118	003
01115316	27	05079062	026
01115426	40	05068013	002
01115434	27	05079062	031
01118659	15	05077917	011
01118664	22	05068283	002
01118669	10	05079185	009
	17	05067639	002
01118673	01	05079161	029
	16	05069035	003
01118700	16	05068258	003
01118718	02	05069057	004
	33	05074236	004
01118737	22	05063419	002
	26	05063365	002
01118748	16	05067624	004
01119241	16	05069035	002
	21	05079002	010
	21	05079003	010
01122477	41	05063108	003
01123690	02	05069057	005
01124445	51	05068119	002
01125637	27	05079062	070
01126975	10	05079021	002
01131075	22	05068283	001
01131115	44	05079007	003
01133631	33	05074236	001

01137083	39	05051119	006
	57	05074297	005
01137646	27	05079062	024
01138774	41	05069183	006
01139875	07	05077922	003
01143531	51	05069029	002
01143874	08	05069155	008
	27	05079062	048
01144510	39	05079237	011
	48	05068273	002
01144536	22	05063419	001
01148122	14	05074219	003
	27	05077923	015
	27	05079062	015
	48	05068111	007
01148123	14	05074219	002
	27	05077923	058
01148134	08	05069155	003
01148153	01	05079161	026
01148207	56	05079085	002
01148241	10	05079174	002
01148426	10	05079185	008
01148543	27	05079062	030
01151016	52	05051756	003
01151181	27	05079062	040
01151319	51	05068119	003
01151441	02	05069057	006
01153346	41	05063108	002
01153347	41	05069183	004
01164748	56	05079085	001
01167425	40	05079125	002
01167428	40	05079125	003
01173940	22	05069171	003
01173941	22	05069171	002
01174416	15	05064400	001
01174482	20	05067542	001
01175634	22	05079206	002
01175981	51	05068119	001
01176435	21	05079002	008
	21	05079170	005
	48	05068111	003
	48	05079133	002
	56	05079139	022
01176558	01	05079188	002
01177045	21	05079002	003
01177369	39	05079237	014
	40	05068215	002
01178468	01	05074210	002
01178666	27	05077923	059
01178672	27	05079118	002
01178747	22	05079206	004
01178753	21	05079170	001
01179016	26	05063365	001

01179079	10	05079197	007
01179564	39	05063354	001
01179598	48	05068111	001
01179622	15	05074378	002
	40	05074284	001
	56	05079139	002
01179631	27	05079062	077
01179656	21	05079170	002
01179835	27	05079062	018
01179934	10	05079185	002
01180014	21	05079002	009
	21	05079170	003
	21	05079171	002
	21	05079172	002
01180059	27	05079062	025
01180079	16	05068258	007
01180080	27	05079062	011
01180144	08	05069155	010
01180228	39	05079237	015
01180446	01	05079161	040
01180460	51	05069029	001
01180693	01	05077818	002
01180751	44	05079007	002
01180886	01	05079161	027
01180887	01	05079161	010
01180888	01	05079161	015
01180889	01	05079161	009
01180891	01	05079161	008
01181006	41	05069183	003
01181389	05	05051754	002
01181390	44	05074199	002
01181417	11	05051930	006
01181418	10	05079185	005
01181419	16	05068258	005
01181420	02	05069057	007
	48	05068111	004
01181421	20	05079014	003
01181422	16	05067625	002
01181423	22	05079206	005
01181424	14	05074219	004
01181425	15	05077896	003
	20	05068026	002
01181426	40	05068215	003
01181433	19	05079013	004
01181695	21	05079171	001
01181751	44	05074199	001
01181784	27	05079062	052
01181872	16	05068258	006
01181882	01	05074210	006
01181985	21	05079002	011
	21	05079003	011
01182004	15	05074378	003
01182090	01	05079161	014



Teileverwendung
Parts Cross Reference
Affectation des No. de Pieces
Asignacion de Nos de Piezas

Datum/Date/Fecha: 27.10.2004 Seite/Page/Pagina: 2 / 3

TN/PN No.P.	BG/CG	ETL	Pos/ Fig
01182107	44	05079007	001
01182135	21	05079002	004
01182249	27	05079062	085
01182348	21	05079172	001
01182349	20	05079014	002
01210161	27	05079062	083
01215850	27	05079062	082
01216110	39	05051119	008
01219780	27	05079062	044
01318659	44	05074199	008
01319265	44	05074199	006
01319761	44	05074199	011
01319920	44	05074199	007
01320257	44	05074199	009
01340070	44	05074199	005
01340330	17	05079214	010
01340331	17	05079214	011
01340332	17	05079214	012
01340333	17	05079214	013
01398465	10	05079197	003
01404948	21	05079170	004
01404949	21	05079171	003
01404950	21	05079172	003
02108055	01	05079161	004
02108102	08	05074211	013
02108134	01	05079161	016
02108176	10	05079185	006
02108526	39	05079237	951
02108527	39	05079237	952
02108643	08	05074211	951
02108690	39	05079237	013
02108691	39	05079237	950
02108929	27	05079062	053
02109066	52	05069152	002
02109085	11	05067617	001
02109563	39	05079237	953
02109628	11	05051930	002
02109636	11	05051930	003
02109637	11	05051930	004
02109988	05	05074151	003
02112403	10	05079021	004
02231136	15	05077917	010
02249331	48	05068111	005
02404201	17	05079205	003
02928961	05	05068138	003
02928962	05	05068138	953
02929801	05	05068138	950
02929924	02	05069057	001
02931141	90	05074086	001
02931435	90	05077823	001
02931485	10	05079185	010
03362279	01	05079161	017
03381013	27	05079062	038

04153728	08	05074211	010
04170393	06	05077880	004
04170394	06	05077880	953
04170886	27	05067616	003
04172349	52	05051756	001
04172446	41	05063108	004
04172490	41	05063108	001
04172492	57	05074297	004
04172724	57	05074297	002
04173067	10	05079174	001
04173227	05	05051754	001
04173414	07	05077922	002
04173550	05	05074230	003
04173862	41	05069183	002
04173918	39	05079237	010
04174032	41	05069183	005
04174058	11	05051930	007
04174827	27	05079118	001
04174892	27	05077923	056
04175031	39	05051119	010
04175391	27	05079118	004
04175433	01	05079188	003
04175434	27	05079062	051
04175435	27	05079062	050
04175629	27	05079062	008
04175724	56	05079085	007
04175945	27	05079062	010
04176057	27	05067616	002
04176260	39	05079237	003
04176261	39	05079237	008
04176288	57	05074297	001
04176380	39	05067679	001
04178075	11	05067617	002
04178154	01	05079161	003
04178202	27	05079062	027
04178205	16	05067625	001
04178218	01	05079161	011
04178238	01	05079161	019
04178261	27	05079062	023
04178358	40	05068013	001
04178390	16	05067624	001
04178423	16	05067624	002
04178431	48	05068115	001
04178452	01	05079161	025
04178522	17	05079205	004
04178523	17	05079205	952
04178524	17	05079205	954
04178525	17	05079205	956
04178526	17	05079205	958
04178527	17	05079205	960
04178528	17	05079205	962
04178572	27	05079062	049
04178611	08	05077836	002

04178612	14	05074219	005
04178691	20	05068026	001
04178741	01	05079161	005
04178839	27	05079062	017
04178895	27	05079062	066
04178989	14	05074219	006
04179131	48	05067715	001
04179138	08	05067612	001
04179404	15	05074378	004
04179633	08	05074211	011
04179711	48	05068115	002
04179751	22	05079206	003
04179754	27	05079062	028
04179809	27	05067616	001
04179928	01	05079161	018
04190904	48	05068111	002
04190904	48	05068111	006
04207255	16	05068258	002
04258757	15	05077896	005
04258758	15	05077896	004
04258759	15	05077896	006
04270055	39	05067681	001
04270236	05	05068138	001
04270238	05	05068138	002
04270242	05	05068138	951
04270247	05	05068138	952
04270255	05	05068138	004
04270259	05	05068138	954
04270263	05	05068138	955
04270292	40	05068215	001
04270312	01	05079161	012
04270364	27	05079062	054
04270443	16	05068258	001
04270463	27	05079062	081
04270491	27	05079062	033
04270503	16	05069035	001
04270729	39	05067681	002
04270815	08	05077836	001
04270940	39	05079237	002
04270979	52	05069152	001
04271076	08	05069155	002
04271079	08	05069155	001
04271080	01	05074210	004
04271160	16	05068258	004
04271176	41	05069183	001
04271258	22	05069171	001
04271453	01	05079161	007
04271850	08	05069155	009
04272011	08	05074211	953
04272035	08	05074211	950
04272081	06	05077880	001
04272421	05	05074151	002
04272425	05	05074151	001



Teileverwendung
Parts Cross Reference
Affectation des No. de Pieces
Asignacion de Nos de Piezas

Datum/Date/Fecha: 27.10.2004 Seite/Page/Pagina: 3 / 3

TN/PN No.P.	BG/CG	ETL	Pos/ Fig
04272546	05	05074230	001
04272765	27	05079062	005
04272815	01	05077818	001
04272923	17	05079205	964
04272924	17	05079205	966
04272956	56	05079085	012
04272968	48	05079133	001
04272973	56	05079139	001
04280016	06	05077880	002
04280024	08	05074211	003
04280025	08	05074211	012
04280047	08	05074211	002
04280049	08	05074211	009
04280116	05	05074230	004
04280136	05	05074230	002
04280144	10	05079197	004
04280156	27	05079062	021
04280165	14	05074219	001
04280264	08	05074211	001
04280280	08	05074211	952
04280347	01	05074210	001
04280404	08	05074211	008
04280483	57	05074297	007
04280484	57	05074297	003
04280566	07	05077922	004
04281060	08	05077836	003
04281061	08	05077836	004
04281062	08	05077836	005
04281090	15	05074378	001
04281147	19	05079013	003
04281188	27	05079062	047
04281195	27	05079062	076
04281196	27	05079062	075
04281204	15	05077896	001
04281205	15	05077896	002
04281218	27	05079062	079
04281298	27	05079062	080
04281321	15	05077917	002
04281429	21	05079002	002
04281437	43	05079011	001
04281461	07	05077922	001
04281633	17	05079205	961
04281634	17	05079205	963
04281635	17	05079205	968
04281859	19	05079013	006
04281870	21	05079003	002
04281876	21	05079015	001
04281898	27	05079062	036
04281941	01	05079161	001
04286046	27	05079062	032
04286057	27	05079062	029
04286113	20	05079014	001
04286120	27	05079062	006

04286122	17	05079205	005
04286159	27	05079062	084
04286236	19	05079013	002
04286243	27	05079062	001
04286251	19	05079013	001
04286355	27	05079118	005
04286391	40	05079156	001
04286403	22	05079206	001
04286436	01	05079188	001
04286503	40	05079125	001
04286544	10	05079185	001
04286587	17	05079205	951
04286588	17	05079205	953
04286589	17	05079205	955
04286590	17	05079205	957
04286591	17	05079205	959
04286592	17	05079205	965
04286593	17	05079205	967
04286644	39	05079237	001
04286651	10	05079197	001
04286672	10	05079174	003
04286696	17	05079205	969
04286701	10	05079197	002
04286792	17	05079214	001
04286793	17	05079205	001
06218864	05	05068138	006