

# ALL IN ONE BOX

Pavers and Screeds



*Atlas Copco*



## ***CONTENTS:***

	<b>Page</b>
Maintenance kits	4
Rubber hopper kit	8
Conveyor chain kits	9
Conveyor guide kits	10
Conveyor plate kits	10
Wear part kits	11
Baffle kits	11
Rubber pad kits	11
Auger wear part kits	12
Screed wear part kits	13
Screed plate kits	15
Gas hose kits	16
Tamper bar kits	17
Tamper guide plate kits	17
Heating elements kits	17

# ALL IN ONE BOX

## Pavers and Screeds

An Atlas Copco all-in-one kit brings you many benefits. Our kits feature selected quality parts that will make it quick and easy to overhaul your machines. To simplify things as much as possible, we have collected related parts to kits and put them in one box. This makes it easy for you to order your kit and receive it on time.

Using genuine parts ensures that your Atlas Copco product is maintained to factory specifications, minimizing operating costs. And best of all, a kit is much cheaper than buying the items individually.



# Maintenance kits

## VERSION 1

Model	Engine	Remark	500 hours	1000 hours
F4C	F3L 1011F - COM1		4729900106	4729900107
F4C/F5C	from Engine No. 0068656		4729900097	4729900098
F4C/F5C	Starting from cat. page: D230-0005B		4729900094	4729900095
F4C/F5C/CS	F3L 2011 - COM2		D299000546	D299000547
F5CS	D2011L3I - COM3		D299000546	D299000556
F5C	D2011L3I - COM3		D299000853	D299000854
F5CS/CS-E	TCD2011L03 - COM3		D299000853	D299000852
F6C	TD2011 L04I	Valid for SN 8750101-8750106	D299000754	D299000755
F6C	TD2011 L04I COM3	Valid for SN 8750100 and from SN 8750107	D299000754	4812025554
F6W	TD2011 L04I	Valid for SN 874300-874307	D299000754	D299000755
F6W	TD2011 L04I COM3	Valid from SN 874308	D299000754	4812025554
F8W	Water-cooled BF4M 1012	Up to SN 876128 (not 876126)	4700688672	4700688673
F8W	Water-cooled BF4M 1012	678100 to 678171	4700688672	4700688673
F8W	Water-cooled BF4M 1012 COM2	For SN 876126 and from 876129	4700690727	4700690728
F8C	Water-cooled BF4M 1012	up to SN 877129	4700690130	4700690230
F8C	Water-cooled BF4M 2012 COM2	from SN 877131	4700691270	4700691271
F9W	Water-cooled BF4M 1012		4700690130	4700690131
F9W	Water-cooled BF4M 2012 COM2	from SN 878137	4700691270	4700690272
F12C/W	Air-cooled, F6L912F		4700688665	4700688661
F14C	Air-cooled, F6L912F		4700688662	4700688664
F15C	Air-cooled, BF 6L913		4700688662	4700688664
F16W	Air-cooled, F6L912F		4700688665	4700688661
F161W	6BT5.9-C126		4700688080	4700688081
F161W	TCD2013 L04	(w/o bio oil)	D299000752	4700691334
F161W	TCD 2013 L04V COM3	(2-belt version)		D299000890
F161W	QSB6.7 COM3	(w/o bio oil)	4700691229	4700691337
F161W	QSB6.7 COM3	(with bio oil)	4700691229	4700691338
F18W	Air-cooled, BF 6L913		4700688662	4700688664
F121C/W	6BT5.9-C126	(w/o belts)	4700688080	4700688081
F121C/W	TCD 2013 L04 COM3	(2-belt version)		D299000890
F121C	TCD 2013 L04		D299000752	4700691334
F121C/W	TCD 2013 L06V COM3	(w/o bio oil)	4700691333	4700691335
F121C/W	TCD 2012 L06V COM3	(w/o bio oil)	4700691333	D299000751
F121C/W	TCD 2012 L06V COM3	(2-belt version)	4700655103	D299000892
F121W	QSB6.7 COM3	(w/o bio oil)	4700691229	4700691337
F121W	QSB6.7 COM3	(with bio oil)	4700691229	4700691338
F14C	BT5.9-C148	up to SN 655103	4700688080	4700688081
F141C/CR	TCD 2013 L06V COM3	(w/o bio oil)	4700691333	4700691335
F141C/CR	TCD 2013 L06V COM3	(2-belt version)		D299000891
F141CR	QSB6.7 COM3	(w/o bio oil)	4700691229	4700691337
F141CR	QSB6.7 COM3	(with bio oil)	4700691229	4700691338
F150C	BF6M 2012C		D299000460	4700690770
F150C	TCD 2012 L06V COM3	(w/o bio oil) from SN 769141	4812025552	4812025553
F150C	TCD 2012 L06V COM3	(2-belt version)		D299000892
F150C	TCD 2012 L06V COM3	Valid from SN 769141	4812025552	4812025553
F151C	BF6M 1013 EC		4700688665	4700690768
F181C	QSB 6.7 - COM	rigid engine mount	4700691229	4812030498

VERSION 1

Model	Engine	Remark	500 hours	1000 hours
F181C/W	6BTA5.9-C166		4700688082	4700688083
F181C/CS	QSB6.7 COM3	(w/o bio oil)	4700691229	4700691337
F181C/CS	QSB6.7 COM3	(with bio oil)	4700691229	4700691338
F181W	QSB C205		4700688082	4700688083
F182C	6BT5.9-C126		4700688665	4700690461
F25C/W	6BT5.9-C126		4700688080	4700688081
F30C/W	6BTA5. 9-C200		4700688082	4700688083
F30CE	C8.3-C230		4700688084	4700688085
F2500C/CS	QSB 6.7 - COM3	first series	4700691229	4812041235
F2500C/CS	QSB 6.7 - COM3	stage 2, valid for SN OG000974, 977, 981, 984, 990-993, 995, 999-1002, 1008, 1011, 1016-1018, 1020, 1024, 1025, ff	4700691229	4812046969
F2500C/CS	QSB 6.7 - COM4	valid for SN OG000564, 714, 720-721, 727, 733, 750, 813, 1007	4812042198	4812042200
F2500C/CS	QSB 6.7 - COM4	interim stage 2, valid for SN OG000998, 1088, 1105, 1153, 1157, 1190, 1231-1232, 1237, ff	4812042198	4812046970
F2500C/CS	QSB 6.7 - COM4	interim stage 2, valid for SN OG000979, 985, 1039-1041, 1067, 1077, 1087, 1119, 1215, 1218, 1226, 1228, 1249, ff	4812012378	4812012384
F2500C/CS	QSB 6.7 - COM3	start-up kit with oil	4812043983	
F2500C/CS	QSB 6.7 - COM4	start-up kit with oil, valid for OG000564, 714, 718, 720-721, 727, 733, 750, 813, 998, 1007, 1088, 1105, 1153, 1157, 1190, 1231-1232, 1237, ff	4812043984	
F2500C/CS	QSB 6.7 - COM4	start-up kit with oil, valid for OG000979, 985, 1010, 1039-1041, 1067, 1077, 1087, 1119, 1215, 1218, 1226, 1228, ff	4812012382	
SD2500C/CS	QSB 6.7 - COM3	first series	4700691229	4812041235
SD2500C/CS	QSB 6.7 - COM3	stage 2, valid for SN OG000974, 977, 981, 984, 990-993, 995, 999-1002, 1008, 1011, 1016-1018, 1020, 1024, 1025, ff	4700691229	4812046969
SD2500C/CS	QSB 6.7 - COM4	valid for SN OG000564, 714, 720-721, 727, 733, 750, 813, 1007	4812042198	4812042200
SD2500C/CS	QSB 6.7 - COM4	interim stage 2, valid for SN OG000998, 1088, 1105, 1153, 1157, 1190, 1231-1232, 1237, ff	4812042198	4812046970
SD2500C/CS	QSB 6.7 - COM4	valid for SN OG001010	4812012378	4812012383
SD2500C/CS	QSB 6.7 - COM4	interim stage 2, valid for SN OG000979, 985, 1039-1041, 1067, 1077, 1087, 1119, 1215, 1218, 1226, 1228, 1249, ff	4812012378	4812012384
SD2500C/CS	QSB 6.7 - COM3	start-up kit with oil	4812043983	
SD2500C/CS	QSB 6.7 - COM4	start-up kit with oil, valid for OG000564, 714, 718, 720-721, 727, 733, 750, 813, 998, 1007, 1088, 1105, 1153, 1157, 1190, 1231-1232, 1237, ff	4812043984	
SD2500C/CS	QSB 6.7 - COM4	start-up kit with oil, valid for OG000979, 985, 1010, 1039-1041, 1067, 1077, 1087, 1119, 1215, 1218, 1226, 1228, ff	4812012382	
SD2500WS	QSB 6.7 - COM3	first series	4700691229	4812041235
SD2500WS	QSB 6.7 - COM3	stage 2, valid for SN OG000974, 977, 981, 984, 990-993, 995, 999-1002, 1008, 1011, 1016-1018, 1020, 1024, 1025, ff	4700691229	4812046969
SD2500WS	QSB 6.7 - COM4	valid for SN OG000564, 714, 720-721, 727, 733, 750, 813, 1007	4812042198	4812042200
SD2500WS	QSB 6.7 - COM4	interim stage 2, valid for SN OG000998, 1088, 1105, 1153, 1157, 1190, 1231-1232, 1237, ff	4812042198	4812046970
SD2500WS	QSB 6.7 - COM4	interim stage 2, valid for SN OG000979, 985, 1039-1041, 1067, 1077, 1087, 1119, 1215, 1218, 1226, 1228, 1249, ff	4812012378	4812012384
SD2500WS	QSB 6.7 - COM3	start-up kit with oil	4812043983	
SD2500WS	QSB 6.7 - COM4	start-up kit with oil, valid for OG000564, 714, 718, 720-721, 727, 733, 750, 813, 998, 1007, 1088, 1105, 1153, 1157, 1190, 1231-1232, 1237, ff	4812043984	

VERSION 1

Model	Engine	Remark	500 hours	1000 hours
SD2500WS	QSB 6.7 - COM4	start-up kit with oil, valid for 0G000979, 985, 1010, 1039-1041, 1067, 1077, 1087, 1119, 1215, 1218, 1226, 1228, ff	4812012382	
SD2550C/CS	QSB 6.7 - COM3	first series	4700691229	4812041235
SD2550C/CS	QSB 6.7 - COM3	stage 2, valid for SN 0G000974, 977, 981, 984, 990-993, 995, 999-1002, 1008, 1011, 1016-1018, 1020, 1024, 1025, ff	4700691229	4812046969
SD2550C/CS	QSB 6.7 - COM4	valid for SN 0G000564, 714, 720-721, 727, 733, 750, 813, 1007	4812042198	4812042200
SD2550C/CS	QSB 6.7 - COM4	interim stage 2, valid for SN 0G000998, 1088, 1105, 1153, 1157, 1190, 1231-1232, 1237, ff	4812042198	4812046970
SD2550C/CS	QSB 6.7 - COM4	interim stage 2, valid for SN 0G000979, 985, 1039-1041, 1067, 1077, 1087, 1119, 1215, 1218, 1226, 1228, 1249, ff	4812012378	4812012384
SD2550C/CS	QSB 6.7 - COM3	start-up kit with oil	4812043983	
SD2550C/CS	QSB 6.7 - COM4	start-up kit with oil, valid for 0G000564, 714, 718, 720-721, 727, 733, 750, 813, 998, 1007, 1088, 1105, 1153, 1157, 1190, 1231-1232, 1237, ff	4812043984	
SD2550C/CS	QSB 6.7 - COM4	start-up kit with oil, valid for 0G000979, 985, 1010, 1039-1041, 1067, 1077, 1087, 1119, 1215, 1218, 1226, 1228, 1228, ff	4812012382	
F1700W/WS	DeutzTD 2011 L04 - COM3		D299000754	4812025554
F1700C	DeutzTD 2011 L04 - COM3		D299000754	4812025554
F1200C/CS	DeutzTD2.9 - COM3		4812009772	4812009775
	DeutzTD2.9 - COM4		4812009772	4812009686
MF300C	BF6M1013 - COM2		4700690727	4812031838
MF300C	QSB6.7 - COM3		4700691229	4812037637
F300CS	BFM1015C - COM2		4812031836	4812031837
AM300	BF6M1013FC - COM2		4700690727	4812031835
DF65P/C	Deutz BF4L2011, COM2	valid for SN 874125 - 874145, 874147, 874149 -874152, 874155 - 874157, 874159, 874163	D299000474	D299000475
DF65P/C	Deutz BF4L2011, COM2	valid for SN 874146,874148, 874153, 874154, 874158, 874160-874162, 874164-874176, 874179-874180, 874182-874188, 874190, 874191, 874193-874198, 874201, 874202, 874204	D299000586	D299000587
DF65P/C	Deutz BF4L2011, COM2	valid for SN 874177, 874178, 874181, 874189, 874192, 874199, 874200, 874203, from 874205	D299000631	D299000632
DF65P/C	DeutzTD2011 L04, COM3	valid SN from 874308	D299000754	4812025554
DF85P	Deutz BF4M1012, COM1	valid from SN 678100 to s/n 678171	4700688672	4700688673
DF85P	Deutz BF4M1012, COM1	valid from SN 678172	4700688672	4700688879
DF85P	Deutz BF4M1012, COM1	valid until SN 876128 without s/n 876126	4700688672	4700688673
DF85P	Deutz BF4M2012, COM2	valid SN 876126 and from s/n 876129	4700690727	4700690728
DF90P/C	Deutz BF4M 1012 EC		4729900109	4729900110
DF95P	Deutz BF4M1013, COM1	valid until SN 878136	4700690130	4700690131
DF95P	Deutz BF4M2012C, COM2	valid from SN 878137	4700691270	4700691272
DF110P	Deutz F6L912		4729900103	4729900104
DF115P/C	Deutz BF6M1012, COM1	adjustable pump	4729900165	4729900166
DF115P/C	Deutz BF6M1012, COM1	constant pump	4729900165	D299000227
DF115P/C	Deutz BF6M2012C - COM2	valid until engine SN 0818270	D299000460	D299000469
DF115P/C	Deutz BF6M2012C - COM2	valid until engine SN 0818270, biological oil	D299000460	D299000467
DF115P/C	Deutz BF6M2012C - COM2	valid from engine SN 0818271	D299000460	D299000459
DF115P/C	Deutz BF6M2012C - COM2	valid from engine SN 0818271, biological oil	D299000460	D299000463
DF115P/C	DeutzTCD2012L06 - COM3	valid SN 34137, 34140 - 34150, 34153 - 34165	4700691333	D299000751
DF115P/C	DeutzTCD2013L04 - COM3	valid SN 34131, 34133 - 34136, 34138, 34139	4700691333	4700691334
DF115P/C	DeutzTCD2013L06 - COM3	valid SN 34130, 34132	4700691333	4700691335
DF125P	DeutzTCD2013L06 - COM3	valid SN 34151, 34152, 34167	4700691333	4700691335

## VERSION 1

Model	Engine	Remark	500 hours	1000 hours
DF130P	Deutz F6L912		4729900103	4729900104
DF130P	Deutz F6L913		4729900118	4729900119
DF135P/C	Deutz BF6M1013, COM1	adjustable pump	4729900165	4729900169
DF135P/C	Deutz BF6M1013, COM1	constant pump	4729900165	D299000223
DF135P/C	Deutz BF6M1013, COM1	constant pump, biological oil	4729900165	D299000221
DF135P/C	Deutz BF6M2012C - COM2	valid until engine SN 0818270	D299000460	D299000469
DF135P/C	Deutz BF6M2012C - COM2	valid until engine SN 0818270, biological oil	D299000460	D299000467
DF135P/C	Deutz BF6M2012C - COM2	valid from engine SN 0818271	D299000460	D299000459
DF135P/C	Deutz BF6M2012C - COM2	valid from engine SN 0818271, biological oil	D299000460	D299000463
DF135P/C	DeutzTCD2013L06 - COM3		4700691333	4700691335
DF40/45C	COM1	valid until SN 0068655	4729900106	4729900107
DF40/45C	COM1	valid from engine SN 0068656 until machine SN 23082	4729900094	4729900098
DF40/45C	COM1	valid from SN 23083	4729900094	4729900095
DF40/45C	COM2		D299000546	D299000547
DF40/45C	Deutz D2011L3- COM3		D299000853	D299000854
DF45CS	COM2		D299000546	D299000556
DF45CS	Deutz D2011L3 - COM3		D299000855	D299000852
DF60C	Deutz F3L912		4729900112	4729900113
DF110C	Deutz F6L 912		4729900100	4729900101
DF130C	Deutz F6L 912		4729900100	4729900101
DF130C	Deutz BF6L 913		4729900115	4729900116
DF140C/CS	OM366A/LA		4729900124	4729900125
DF145C/CS	Cummins 6BTA5.9 C200 - COM2		D299000405	D299000406
DF145C/CS	Cummins 6BTA5.9 C200 - COM2	biological oil	D299000405	D299000408
DF145C/CS	Cummins QSB5.9 C205+230		D299000410	D299000411
DF145C/CS	Cummins QSB5.9 C205+230	biological oil	D299000410	D299000413
DF145C/CS	Cummins QSB6.7		4700691229	4700691337
SD115C	DeutzTCD2012L06 - COM3		4700691333	4812034824
SD115C	DeutzTCD2013L06 - COM3		4700691333	4812025792
SD135C	DeutzTCD2012L06 - COM3		4700691333	4812034824
SD135C	DeutzTCD2013L06 - COM3		4700691333	4812025792
MF2500CL/CS	QSB 6.7 - COM3	stage 2	4700691229	4812046969
MF2500CL/CS	QSB 6.7 - COM3	start-up kit with oil	4812043983	
MF2500CL/CS	QSB 6.7 - COM4	interim stage 2	4812042198	4812046970
MF2500CL/CS	QSB 6.7 - COM4	start-up kit with oil	4812043984	

## VERSION 2

Model	Engine	Serial Number from	500 hours	1000 hours
F8W	Water-cooled, BF4M 1012	678172	4700688672	4700688879
F12C+W	Water-cooled, BF6M 1012		4700688665	4700688668
F14C	Water-cooled, BF6M 1012		4700688665	4700688666
F15C	Water-cooled, BF6M 1013		4700688665	4700688666
F16W	Water-cooled, BF6M 1012		4700688665	4700688668
F18C+W	Water-cooled, BF6M 1013		4700688665	4700688666
F141C	BTA5.9-C166	655104	4700688082	4700688083

## VERSION 3

Model	Engine	Serial Number from	500 hours	1000 hours
F12C	Water-cooled, BF6M 1013	755255	4700688665	4700688669
F12W	Water-cooled, BF6M 1012	754272	4700688665	4700688669
F14C	Water-cooled, BF6M 1012	755255	4700688665	4700688667
F15C	Water-cooled, BF6M 1013	769115	4700688665	4700688667
F16W	Water-cooled, BF6M 1012	756260	4700688665	4700688669
F18C	Water-cooled, BF6M 1013	757139	4700688665	4700688667
F18W	Water-cooled, BF6M 1013	756273	4700688665	4700688667

## Rubber hopper kits

Model	Part No.
F2500C / CS, SD2500C/CS, SD2550C/CS Standard	4812045783
SD2500C/CS, SD2550C/CS hydr. hopper	4812045834
F2500W, SD2500W, SD2500WS Standard	4812045835
SD2500W, SD2500WS hydr. hopper	4812045836
F2500C / CS, SD2500C/CS, SD2550C/CS Standard - Version B valid for 0G000974, 988, 998, 1001, 1016, and all following machines	4812007262
F2500W, SD2500W, SD2500WS Standard - Version B valid for 0G000974, 988, 998, 1001, 1016, and all following machines	4812007264
SD2500C/CS, SD2550C/CS, SD2500W/WS hydr. hopper - Version B valid for 0G000974, 988, 998, 1001, 1016, and all following machines	4812007263



# Conveyor chain kits

## VERSION 1

Model	Part No.
11011K	4700679537
11011R	4700679581
12000R/15000K	4700679588
F6C+W (old model)	D299000818
F8C+W	4700679584
F9W	4700679584
F12C+W	4700679581
F14C	4700679581
F15C	4700679632
F16W	4700679588
F18C+W	4700679588
F121C+W	4700679581
F141C+W	4700679581
F141CR (Com 3)	D299000774
F150C/F151C	4700679632
F161W	4700679588
F181C+CS+W	4700679588
SD115C/135C	D299000774
F2500C/CS+SD2500C/CS	4812029178
SD2550C/CS	4812035563
SD2500W/WS	4812029821

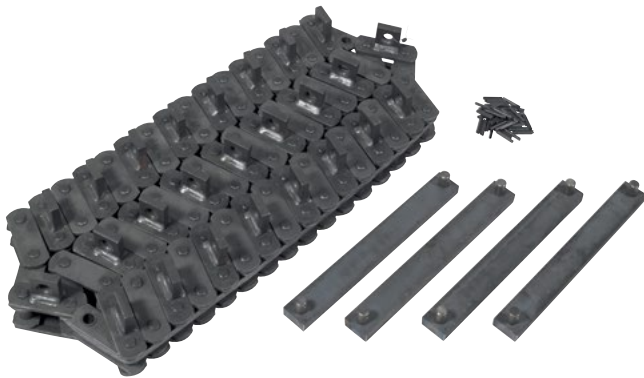

## VERSION 2 - Double qty of bars

Model	Part No.
11011K+R	4700679582
12000R/15000K	4700679589
15000KT	4700679531
F6C+W for 874300 ff and for 8750100 ff	D299000858
F12C+W	4700679582
F14C	4700679582
F15C	4700679632
F16C+W	4700679589
F18C+W	4700679589
F121C+W	4700679582
F141C+W	4700679582
F161W	4700679589
F141CR (Com 3)	D299000773
F150C	4700679632
F181C+W/F182CS	4700679589
F30C+CE+W	4700688743
F300C	4700691174
SD115C/135C	D299000773
F2500C/CS+SD2500C/CS	4812027444
SD2550C/CS	4812028516
SD2500W/WS	4812029822
DF115C+P/DF 135C	4729900154
DF115C+P - COM3	4700679582
DF135C - COM3	4700679582
DF135P	D299000199
DF145C+CS	4729900024
DF145P	4700679589

## Conveyor guide kits

Model	Part No.
11011K	4700679638
11011R	4700679590
12000R/15000K	4700679591
15000 KT	4700679592
F6C+W (old model)	D299000511
F6C+W for 874300 ff and for 8750100 ff	D299000856
F8C+W	4700679593
F9W	4700679593
F12C+W	4700679594
F14C	4700679594
F15C	4700679633
F16C+W	4700679595
F18C+CS+W	4700679595
F121C+W	4700679594
F141C	4700679594
F121C+W - COM3 (hydr. hopper)	D299000701
F121C+W - COM3 (w/o hydr. hopper)	D299000702
F141C+CR+W - COM3 (hydr. hopper)	D299000701
F141C+W - COM3 (w/o hydr. hopper)	D299000702
F141CR - COM3 (w/o hydr. hopper)	D299000776
F150C/F151C	4700679633
F161W	4700679595
F161W - COM3 (hydr. hopper)	D299010060
F181C+W	4700679595
F181C - COM3 (hydr. hopper)	D299010060
F181C - COM3 (w/o hydr. hopper)	4812029359
F182CS	4700690789
F30C+CE+W	4700688741
F300C	4700691175
SD115C/135C (hydr. hopper)	4812025790
SD115C/135C (w/o hydr hopper)	4812025789
F2500C/CS+SD2500C/CS	4812027440
SD2550C/CS	4812028403
DF115C+P/DF/135C	4729900163
DF115C+P - COM3 (hydr. hopper)	D299000701
DF115C+P - COM3 (w/o hydr. hopper)	D299000702
DF135C - COM3 (hydr. hopper)	D299000701
DF135C - COM3 (w/o hydr. hopper)	D299000702
DF135P	D299000200
DF145C+CS (w/o hydr. hopper)	4729900037
DF145C+CS (hydr. hopper)	4812031193
DF145P (w/o hydr. hopper)	4700679595
DF145P (hydr. hopper)	D299010060



## Conveyor plate kits

Model	Part No.
11011K	4700679536
11011R	4700679523
12000R/15000K	4700679527
15000KT	4700679530
F6C+W	D299000512
F6C+W for 874300 ff and for 8750100 ff	D299000857
F8C+W	4700679745
F9W	4700679745
F12C+W	4700679580
F14C	4700679580
F15C	4700679631
F16C+W	4700679587
F18C+CS+W	4700679587
F121C+W	4700679580
F141C	4700679580
F121C+W (COM3)	D299000700
F141C+W (COM3)	D299000700
F141CR (COM3)	D299000775
F150C (COM3)	4700690785
F161W	4700679587
F161W (COM3)	4700690558
F181C/F181W	4700690558
F181C (COM3)	4812029358
F182CS	4700690788
F30C+CE+W	4700688740
F300C	4700691176
SD115C/135C	4812025791
F2500C/CS+SD2500C/CS	4812027441
F2500C/CS short, narrow	4812029190
SD2550C/CS	4812028402
SD2500C/CS short, narrow	4812029190
DF115C+P/DF 135C	4729900155
DF115C+P - COM3	D299000700
DF135C - COM3	D299000700
DF135P	D299000198
DF145C+CS	4729900031
DF145P	4700690558



## Wear part kits

### CONVEYOR DRIVE

Model	Part No.
F6C+W (old model)	D299000817
F6C+W for 874300 ff and for 8750100 ff	D299000859
F12C+W/F121C+W	D299010010
F121C+W - COM3	D299000697
F14C/F141C	D299010010
F141C+W - COM3	D299000697
F141CR- COM3	D299000777
F150C - COM3	D299010010
F16W	D299010010
F161W	D299010010
F181C - COM3	D299010010
F182CS	D299000254
F182CS - COM3	D299000777
SD115C/135C	D299000697
F/SD2500C/CS+SD2550C/CS	4812035552
DF115C+P/DF 135C	D299000421
DF115C+P - COM3	D299000697
DF135C - COM3	D299000697
DF135P	D299000421
DF145C+CS	D299000254
DF145P	D299010010



## Baffle Kit

Model	Part No.
F12C+W/F121C+W	D299010011
F14C/F141C	D299010011
F16W/F161W	D299010011
F/SD2500C/CS+SD2550C/CS	4812035553



## Rubber pad kit

Model	Part No.
15000K+KT	4700679544
F4C/F5C/CS standard version with scraper	D299000346
F4C/F5C/CS CAT version without scraper	D299000386
F6C	D299000589
F8C	4700690353
F12C/F121C/F141C	4700679596
F15C/F150C/F16C/F18C+CS/F181C/F182CS	4700679545
F30C/F30CE	4700688742
F300C	4700691173
11011K	4700679543
SD115C/135C	D299000698
F2500C/CS+SD2500C/CS	4812035550
SD2550C/CS	4812035551
DF115C/DF 135C	4729900055
DF115C - COM3	D299000698
DF135C - COM3	D299000698
DF145C+CS	D299000149
TP2500 (Compact)	4812031960



## LONG CHAIN

Model	Part No.
15000KT	4700679545

## NEW RUBBER PAD KITS

Model	No. Pcs	Rebuild kit	Replace kit
F8C	76	4812025457	4812025463
F12C/ F121C	92	4812025456	4812025462
F14C/F141C	92	4812025456	4812025462
F15C/150C	106	4812025454	4812025460
F18C+CS/F181C	106	4812025454	4812025460
F182CS	106	4812025454	4812025460
15000K	100	4812025451	4812025458
11011K	86	4812025455	4812025461
DF115C/DF 135C	96	D299000758	D299000757
DF115C - COM3	94	4812025453	4812025459
DF135C - COM3	94	4812025453	4812025459
DF145C+CS	100	4812025451	4812025458



# Auger wear part kit

## 310 MM

Model	Part No.
F5 CS/E (For SN: 4550061, 64, 68 and 4550072 ff)	D299000825
F6C+W	D299000714
F8C+W	4700679585
F9W	4700679585
F12C+W	4700679526
F121C+W	4700679526
F141C+W	4700679526
11011K+R	4700679526
12000R	4700679526
15000K+KT	4700679526

## AUGER COMPLETE

Model	Part No.
All units, 310 mm, Fetherkey	D880180700
All units, 310 mm, with tothing	D864181700
All units, 380 mm, with tothing	D756181600
F8C+W, 310 mm	D678181700

## 380 MM BASED ON AUGER OPTION OF THE MACHINE

Model	Part No.
F12C+W	4700679586
F121C+W	4700679586
F15C	4700679586
F16C+W	4700679586
F161W	4700679586
F18C+CS/W	4700679586
F181C+W	4700679586
F30C+CE+W	4700679743
SD115C/135C	D299000509
F2500C+CS/SD2500C+CS	4812027478
DF110P+C/DF115P+C/DF130 P+C	4729900035
DF 115 P/C, 135 P/C	D299000509
DF 145 C	4729900026
DF 145 P (with Dynapac auger)	4700679586
F182CS	D299000509

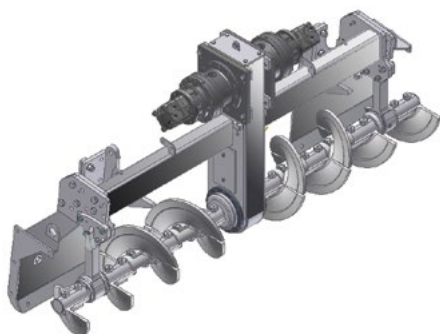

## 430 MM BASED ON AUGER OPTION OF THE MACHINE

Model	Part No.
SD2550C	4812027733
DF 140 C	D299000508
DF 145 CS	D299000508
F181C, (Svedala Demag Schnecke )	D299000508

## 500 mm

Model	Part No.
SD2550CS	4812027736

## L.H.

Model	Part No.
All units, 310 mm	D880182701
All units, 380 mm	D756182711
F4C/F5C/F5CS	D299000819
F6C+W (new version)	D299000821
SD115C/135C	4729900146

## R.H.

Model	Part No.
All units, 310 mm	D880182801
All units, 380 mm	D756182811
F4C/F5C/F5CS	D299000820
F6C+W (new version)	D299000822
SD115C/135C	4729900147

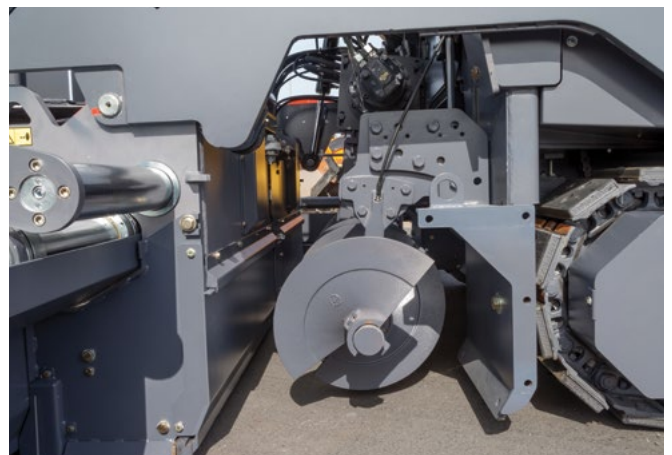

# Screed wear part kits

## HARDOX 400

Model	Serial Number	Part No.
VB 120TV/EB 25 Gas		4729900091
VB 120TV/EB 25 Gas	for 2124-2127 and 2129 ff	D299000253
VB 125TV/EB 28 Gas		D299000257
VB 125TV-E/EB 28 E		D299000652
VB340TV/EB 34 Gas		D299000516
VB340TV-E/EB 34 E		D299000593
VB450TV Gas		4700679557
VB460TV/EB 46 Gas		4729900089
VB5100TV/EB 51Gas	manuf. year 2007	D299000706
VB5100TV-E/EB 51 E	manuf. year 2007	D299000708
VB6000TV/EB 60 Gas	manuf. year 2007	D299000716
VB6000TV-E/EB 60 E	manuf. year 2007	D299000720
EB60/1 Gas		4729900047
EB60/1Plus Gas		4729900046
EB60/2 Gas		4729900048
EB60/3 Gas		4729900049
EB60/4 Gas		4729900040
VB800TV/EB 60/5 Gas		4729900051
VB800TV Plus/EB 60/5 Plus Gas		4729900050
VB805TV/EB 50 Gas	up to SN 6215	4729900156
VB805TV/EB 50 Gas	from SN 6216 ff	D299000193
VB805TV/EB 50 Gas <sup>2</sup>	SN - see below	D299000355
VB805TV-E/EB 50 E	from SN 6585	D299000353
VB805TV-plus/EB 50 Plus Gas	for SN 3318, 3320-3321	D299000216
VB805TV-plus/EB 50 PlusGas	for SN 3319, 3322 ff	D299000357
VB805TV-plus E/EB 50 Plus E		D299000562
VB850TV /Gas		4700679835
VB851TV /Gas		4700679841
VB900TV /Gas		4700679833
VB1000TV /Gas		4700679838
EB70 /Gas		4729900042
EB70/1 Gas		4729900041
EB70/2 Gas		4729900043
EB70/3 Gas		4729900044
EB70/4 Gas		4729900052
VB1100TV/EB 70/5 Gas		4729900045
VB1100TV-Plus/EB 70/5 Plus Gas		4729900058
VB1105TV/EB 75 Gas		4729900161
VB1105TV/EB 75 Gas <sup>3</sup>	SN - see below	D299000359
VB1105TV E/EB 75 E		D299000490
VB1105TV Plus/EB 75 Plus Gas	up to SN 8203	D299000218
VB1105TV Plus/EB 75 Plus Gas	from SN 8204 ff	D299000362
VB1105TV Plus E/EB 75 Plus E		D299000528
SB1250TV/EB 30 Gas		4729900173
SB1250TV/EB 30 Gas	from SN 149	D299000414
V5100TV Gas/E		4812035300
V5100TV H		4812035302
V6000TV H		4812035306
V6000TV Gas/E		4812035304

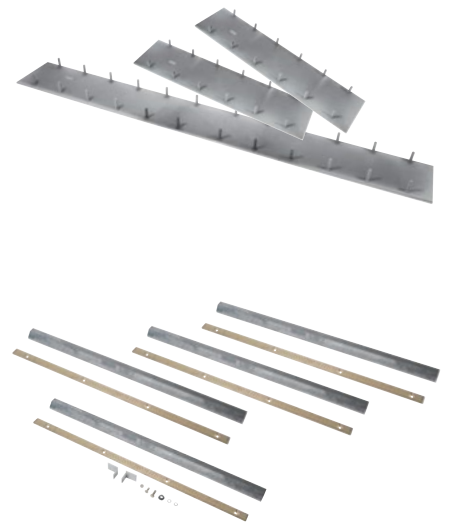

<sup>2</sup> for SN 6526, 6529-6530, 6537-6538, 6542, 6547-6552, 6554-6555 and from 6607ff

<sup>3</sup> for SN: 7233, 7256, 7264, 7269-7272, 7274, 7278, 7280 and from SN 7284 ff

## WITH IGNITION

Model	Serial Number from	Serial Number to	Part No.
SB 1250 TV / EB 30 Gas		149	4729900174
SB 1250 TV / EB 30 Gas		149	D299000436
SB 1250 TV / EB 30 Gas			D299000437

## WITHOUT IGNITION

Model	Serial Number from	Serial Number to	Part No.
SB 1250 TV / EB 30 Gas			4729900170

## AT 250 mm

Model	Serial Number from	Serial Number to	Part No.
SB 1250 TV / EB 30 Gas			4729900172

## AT 500 mm

Model	Serial Number from	Serial Number to	Part No.
SB 1250 TV / EB 30 Gas			4729900171

## AT 750 mm

Model	Serial Number from	Serial Number to	Part No.
SB 1250 TV / EB 30 Gas			D299000326

## HARDOX 500

Model	Serial Number from	Serial Number to	Part No.
VB 125TV / EB 28 Gas			D299000594
VB 125TV-E / EB 28 E			D299000640
VB340TV / EB 34 Gas			D299000534
VB340TV-E / EB 34 E			D299000592
VB460TV / EB 46 Gas			D299000781
VB 5100 TV- / EB 51 Gas	manuf. year 2007		D299000724
VB 5100 TV-E / EB 51 E	manuf. year 2007		D299000726
VB 6000 TV- / EB 60 Gas	manuf. year 2007		D299000718
VB 6000 TV-E / EB 60 E	manuf. year 2007		D299000722
EB 60 / 4 Gas			D299000190
VB 800TV / EB 60/5 Gas			D299000189
VB 805TV / EB 50 Gas	from SN 6216		D299000260
VB 805TV / EB 50 Gas	for SN 6526, 6529-30 ff		D299000483
VB 805TV-E / EB 50 E	for SN 6585		D299000438
VB 805TV-plus / EB 50 Plus Gas	for SN 3319, 3322 ff		D299000635
VB850TV - Gas			4700690556
VB851TV - Gas			4700690648
VB851TV - Gas	with even tamper bars		D299000602
VB 1000TV - Gas			D299000613
VB 1105 TV / EB 75 Gas			D299000496
VB 1105 TV / EB 75 Gas	for SN 7233 and from SN 7284 ff		D299000443
VB 1105 TV E / EB 75 E			D299000441
V 5100 TV Gas/E			4812035301
V5100TV H			4812035303
V6000TV H			4812035307
V 6000 TV Gas/E			4812035305



# Screed plate kits

## HARDOX 400

Model	Serial Number from	Part No.
VB 120TV / EB 25 Gas		4729900090
VB 125TV / EB 26 Gas		4729900092
VB 125 V / EB 27 Gas		D299000258
VB 125TV-Gas +E / EB 28 Gas + E		D299000256
VB340V / EB 34 Gas		D299000515
VB340TV Gas+E / EB 34 Gas +E		D299000517
VB 400V Gas		4700665900
VB 450TV Gas		4700679609
VB460TV / EB 46 Gas		4720006069
VB500V - Gas		4700679509
VB 5100TV- / EB 51Gas	manuf. year 2007	D299000705
VB 5100TV-E / EB 51 E	manuf. year 2007	D299000707
VB 6000TV- / EB 60 Gas	manuf. year 2007	D299000715
VB 6000TV-E / EB 60 E	manuf. year 2007	D299000719
VB 800TV / EB 60/5 Gas		4720003542
VB 800TV Plus / EB 60/5 Plus Gas		4720005406
VB 805TV / EB 50 Gas	up to SN 6215	4729900157
VB 805TV / EB 50 Gas	from SN 6216 ff	D299000192
VB 805TV / EB 50 Gas	for SN 6526, 6529, and from 6530 ff	D299000356
VB 805TV-E / EB 50 E	from SN 6585 ff.	D299000354
VB 805 TV Plus / EB 50 Plus Gas	for SN 3318, 3320-3321	D299000219
VB 805TV Plus / EB 50 Plus Gas	for SN 3319 and from SN: 3222	D299000358
VB 805TV Plus E / EB 50 Plus E		D299000561
VB850TV - Gas		4700679836
VB851TV - Gas		4700679839
VB 1000TV - Gas		4700679840
VB 1105 TV / EB 75 Gas		4729900162
VB 1105TV / EB 75 Gas <sup>3</sup>	SN - see below	D299000360
VB 1105TV E / EB 75 E		D299000489
VB 1105TV Plus / EB 75 Plus Gas	up to SN 8203	D299000217
VB 1105TV Plus / EB 75 Plus Gas	from SN 8204 ff	D299000361
VB 1105TV Plus E / EB 75 Plus E		D299000563
V5100TV Gas/E		4812032394
V5100TV H		4812032423
V6000TV H		4812032749
V6000TV Gas/E		4812032692

<sup>3</sup> for SN: 7233, 7256, 7264, 7269-7272, 7274, 7278, 7280 and from SN 7284 ff



## HARDOX 500

Model	Serial Number from	Part No.
VB 125TV / EB 28 Gas		D255011500
VB 125TV-E / EB 28 E		D255011500
VB340TV Gas+E/ EB 34 Gas+E		4720008251
VB 5100 TV- / EB 51 Gas	manuf. year 2007	D299000723
VB 5100 TV-E / EB 51 E	manuf. year 2007	D299000725
VB 6000 TV- / EB 60 Gas	manuf. year 2007	D299000717
VB 6000 TV-E / EB 60 E	manuf. year 2007	D299000721
VB 805TV / EB 50 Gas	for SN 6526, 6529, 6530 ff	D299000482
VB 805TV-E / EB 50 E	for SN 6585 ff	D299000439
VB 1105 TV / EB 75 Gas		D299000497
VB 1105 TV / EB 75 Gas	for SN 7233 and from SN 7284 ff	D299000444
VB 1105 TV E/ EB 75 E		D299000442
V 5100 TV Gas/E		4812032411
V5100TV H		4812032441
V6000TV H		4812032754
V 6000 TV Gas/E		4812032693

### SCREED WEAR PART KIT Deeper screed plates (ext. parts)-H400

Model	Serial Number	Part No.
VB805TV/EB 50 Gas	from SN 6216	D299000665
VB805TV/EB 50 Gas	for SN 6526,6529,6530ff	D299000662
VB805TV-E/EB 50 E	6585 ff	D299000669
VB1105TV/EB 75 Gas		D299000660

### SCREED WEAR PART KIT Deeper screed plates (ext. parts)-H500

Model	Serial Number	Part No.
VB805TV/EB 50 Gas	from SN 6216	D299000664
VB805TV/EB 50 Gas	for SN 6526, 6529, 6530ff	D299000663
VB805TV-E/EB 50 E	6585 ff	D299000668
VB1105TV/EB 75 Gas		D299000661

## Gas hose kits



Model	Serial Number	Part No.
VB120V/ Gas		D299000337
VB120TV/ EB 25 Gas		D299000338
VB125TV/ EB 26 Gas		D299000336
VB125TV/ EB 28 Gas		D299000339
VB340V/ EB 34 Gas		D299000738
VB340TV/ EB 34 Gas		D299000738
VB450V/ Gas		D299000812
VB450TV/Gas		D299000811
VB460TV/ EB 46 Gas		D299000465
VB5100TV/ EB 51 Gas	manuf. year 2007	D299000713
VB6000TV/ EB 60 Gas	manuf. year 2007	D299000735
VB800TV/ EB 60/5 Gas		D299000335
VB800TV Plus/ EB 60/5 Plus Gas		D299000335
VB805TV/ EB 50 Gas		D299000340
VB805TV Plus/ EB 50 Plus Gas		D299000428
VB850TV/ Gas	with ignition	D299000813
VB851TV/ Gas	up to SN 84765412	D299000814
VB851TV/ Gas	from SN 84765413	D299000815
VB1100TV/ EB 70/5 Gas		D299000334
VB1100TV Plus/ EB 70/5 Plus Gas		D299000333
VB1105TV/ EB 75 Gas		D299000341
VB1105TV Plus/ EB 75 Plus Gas		D299000342
V5100TV/Gas		4812035287
V6000TV/Gas		4812035288



## Tamper bar kits

Model	Part No.
VB850TV - Gas	4700679706
VB1000TV - Gas	4700679707
V5100TV - Gas+E	4812038826
V5100TV H	4812038826
V6000TV H	4812038827
V6000TV - Gas+E	4812038827

### BEARING SET - TAMPER DRIVE

Model	Part No. One section	Part No. Full screed
VB5100TV/ EB 5Gas	D299000249	D299000255
VB5100TV E/ EB 51E	D299000249	D299000255
VB6000TV/ EB 60Gas	D299000249	D299000255
VB6000TV E/ EB 60E	D299000249	D299000255
VB800TV/ EB 60/5 Gas	D299000205	D299000201
VB800TV Plus/ EB 60/5 Plus Gas	D299000205	D299000201
VB805TV/ EB 50Gas	D299000249	D299000255
VB805TV E/ EB 50E	D299000249	D299000255
VB805TV Plus/ EB 50Plus Gas	D299000249	D299000255
VB805TV E Plus/ EB 50E Plus	D299000249	D299000255
VB1100TV/ EB 70/5 Gas	D299000205	D299000201
VB1100TV Plus/ EB 70/5 Plus Gas	D299000205	D299000201
VB1105TV/ EB 75Gas	D299000249	D299000255
VB1105TV E/ EB 75E	D299000249	D299000255
VB1105TV Plus/ EB 75 Plus Gas	D299000249	D299000255
VB1105TV E Plus/ EB 75E Plus	D299000249	D299000255
V5100TV/ Gas +E	D299000249	D299000255
V6000TV/ Gas +E	D299000249	D299000255

### BEARING SET - ROCKER ASSY

Model	Part No.
VB 5100TV / EB 51Gas	
VB 5100TV-E / EB 51E	D299000250
VB 6000TV- / EB 60 Gas	D299000250
VB 6000TV- E/ EB 60 E	D299000250
VB 800TV / EB 60/5 Gas	D299000250
VB 800TV Plus / EB 60/5 Plus Gas	D299000203
VB 805TV / EB 50 Gas	D299000203
VB 805TV-E / EB 50 E	D299000250
VB 805TV Plus / EB 50 Plus Gas	D299000250
VB 805TV- E Plus / EB 50 E Plus	D299000250
VB 1100TV / EB 70/5 Gas	D299000250
VB 1100TV Plus/ EB 70/5 Plus Gas	D299000203
VB 1105TV / EB 75 Gas	D299000203
VB 1105TV-E / EB 75 E	D299000250
VB 1105TV Plus / EB 75 Plus Gas	D299000250
VB 1105TV-E Plus / EB 75 E Plus	D299000250
V 5100TV Gas + E	D299000250
V 6000TV Gas + E	D299000250

## Tamper guide plate kits

Model	Part No.
VB340V/ EB 34 Gas	D299000514
VB340TV/ EB 34 Gas	D299000513
VB340TV E/ EB 34 E	D299000513
VB450TV/ Gas	4700679601
VB500V/ Gas	4700679597
VB500TV/ Gas	4700679597
VB5100TV/ EB 51Gas *	D299000712
VB5100TV E/ EB 51E *	D299000712
VB6000TV/ EB 60 Gas *	D299000734
VB6000TV E/ EB 60 E *	D299000734
VB800TV/ EB 60/5 Gas	D299000430
VB800TV Plus/ EB 60/5 Plus Gas	D299000430
VB805TV/ EB 50 Gas	D299000431
VB805TV E/ EB 50 E	D299000431
VB805TV Plus/ EB 50 Plus Gas	D299000431
VB805TV E Plus/ EB 50 E Plus	D299000431
VB851TV/ Gas	4700679598
VB1000TV/ Gas	4700679600
VB1105TV/ EB 75 Gas	D299000432
VB1105TV E/ EB 75 E	D299000432
VB1105TV Plus/ EB 75 Plus Gas	D299000432
VB1105TV E Plus/ EB 75 E Plus	D299000432
V5100TV/ Gas + E	4812035289
V6000TV/ Gas + E	4812035549

\* Manuf. year 2007

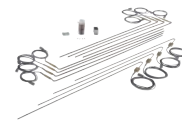

## Heating element kits

Model		Part No.
VB125TV E/ EB 28 E	one section	D299000865
VB340TV E/ EB 34 E	full screed	D299000625
VB340TV E/ EB 34 E	one section	D299000864
VB5100TV E/ EB 51E	full screed	D299000709
VB5100TV E/ EB 51E	one section	D299000861
VB6000TVE/ EB 60 E	full screed	D299000710
VB6000TV E/ EB 60 E	one section	D299000862
VB805TV E/ EB 50 E	one section	D299000863
VB805TV E/ EB 50 E	full screed	D299000484
VB805TVE Plus/ EB50 E Plus	full screed	D299000486
VB1105TV E/ EB 75 E	full screed	D299000485
VB1105TVE Plus/ EB75 E Plus	full screed	D299000487
V5100TV E	full screed	4812035291
V5100TV E	one section	4812035296
V6000TV E	full screed	4812035293
V6000TV E	one section	4812035298

### STRONGER

Model	Part No.
VB 805TV-E / EB 50 E	full screed D299000596



# ***ANYTIME ANY PRODUCT ANYWHERE***

## ***You can count on us***

Servicing your machines regularly is very important to ensure reliable operation and a long service life. With proactive service and preventive maintenance, you minimize the risk of high production costs and breakdowns.

# GO MOBILE

## Construction App

Find all the information about Atlas Copco Construction Technique's products and services.

## BUILD App

Be informed about trends and applications in the global construction market!

## Parts Online

User-friendly platform to find the spare parts and books for construction equipment.

## Shop Online

Handle your orders 24 hours a day. Fast, easy and safe.



Visit us at [altascopco.com/ConstructionPortal](http://altascopco.com/ConstructionPortal)

## ***COMMITTED TO SUSTAINABLE PRODUCTIVITY***

We stand by our responsibilities towards our customers, towards the environment and the people around us. We make performance stand the test of time. This is what we call Sustainable Productivity.

[atlascopco.com](http://atlascopco.com)

***Atlas Copco***