



# INDIRECT ENGINE SHIPPING NOTICE

The following equipment powered with Cummins engines has been shipped :

**Date** : .....

**From** :

OEM Name : .....  
Address : .....

**To** :

Distributor / Dealer Name : .....  
Address : .....

<u>Equipment Model</u>	<u>Cummins Engine Model</u>	<u>Cummins Engine Serial No.</u>	<u>Ultimate Owner or User's Name &amp; Address</u>	<u>Date Shipped</u>
1. ....	.....	.....	.....	.....
2. ....	.....	.....	.....	.....
3. ....	.....	.....	.....	.....
4. ....	.....	.....	.....	.....

Please return to : Cummins Diesel N.V.  
Blarenberglaan 4  
Industriepark Noord 2  
2800 Mechelen  
BELGIUM

Prepared by : .....

**Notice to Manufacturer :**

Cummins Engine Company needs to know the location of our products to provide proper service support. Normally, delivery information is available only from you or your dealer. Please complete this form when new equipment is shipped from your factory or warehouse to a dealer or customer. The information will be forwarded to the local Cummins Distributor to ensure proper service and parts support for the engine.

4

5

6

7

8

9

10



# Owners Manual B3.9, B4.5, and B5.9 Industrial Series Engines

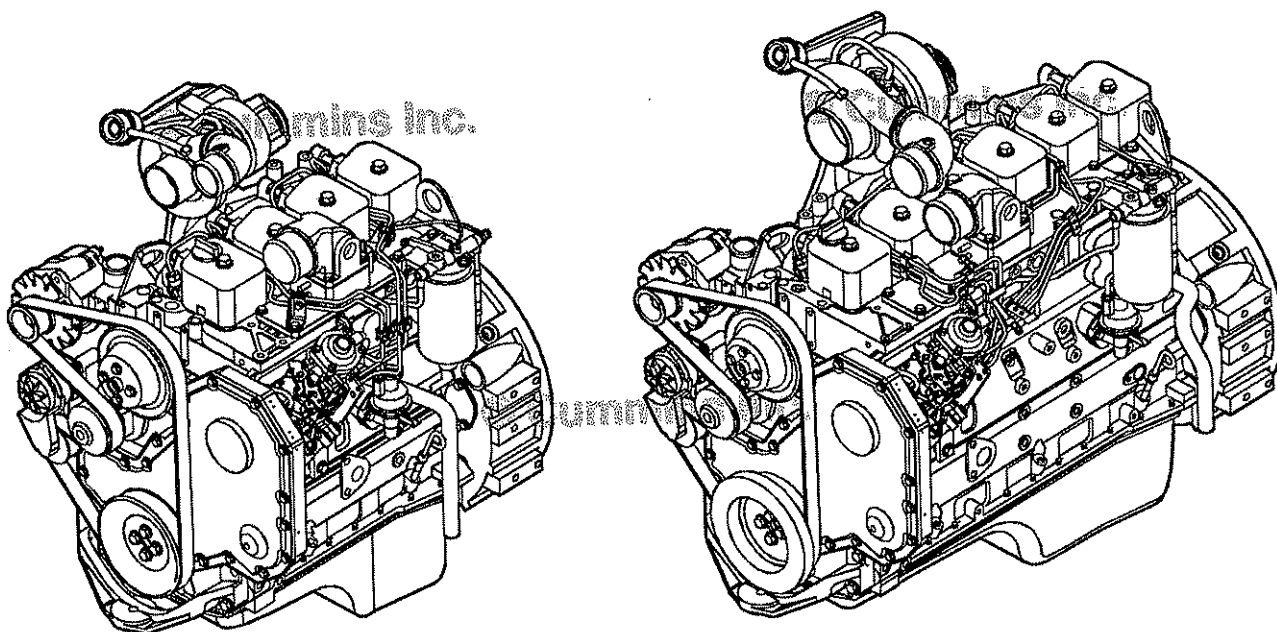

© B3.9mins Inc.

© B5.9mins Inc.

## Foreword

This manual contains information for the correct operation and maintenance of your Cummins engine.

**Read and follow all safety instructions. Refer to the WARNING in the General Safety Instructions in Section i - Introduction.**

Keep this manual with the equipment. If the equipment is traded or sold, give the manual to the new owner.

The information, specifications, and recommended maintenance guidelines in this manual are based on information in effect at the time of printing. Cummins Inc. reserves the right to make changes at any time without obligation. If you find differences between your engine and the information in this manual, contact your local Cummins Authorized Repair Location or call 1-800-DIESELS (1-800-343-7357) toll free in the U.S. and Canada.

The latest technology and the highest quality components were used to produce this engine. When replacement parts are needed, we recommend using only genuine Cummins or ReCon® exchange parts. These parts can be identified by the following trademarks:



**NOTE:** Warranty information is located in Section W. Make sure you are familiar with the warranty or warranties applicable to your engine.

# Table of Contents

	Section
Introduction .....	i
Engine Identification .....	E
Operating Instructions .....	1
Maintenance Guidelines .....	2
Service Literature .....	L
Maintenance Specifications .....	V
Warranty .....	W

## Important Reference Numbers

Fill in the part name and number in the blank spaces provided below. This will give you a reference whenever service or maintenance is required.

Part Name	Part Number	Part Number
Engine Model		
Engine Serial Number (ESN)		
Control Parts List (CPL)		
Fuel Pump Part Number		
Electronic Control Module (ECM)		
Electronic Control Module Serial Numbers (ECM)		
Filter Part Numbers:		
• Air Cleaner Element		
• Lubricating Oil Filter		
• Fuel		
• Fuel-Water Separator		
• Coolant		
• Remote Gas		
Governor Control Module (GCM) (if applicable)		
Belt Part Numbers:		
•		
•		
•		
Clutch or Marine Gear (if applicable):		
• Model		
• Serial Number		
• Part Number		
• Oil Type		
• Sea Water Pump		
- Model		
- Part Number		

# Section i - Introduction

## Section Contents

	Page
<b>Acronyms and Abbreviations</b> .....	i-5
General Information.....	i-5
<b>General Safety Instructions</b> .....	i-3
Important Safety Notice.....	i-3
<b>Illustrations</b> .....	i-2
General Information.....	i-2
<b>Symbols</b> .....	i-1
General Information.....	i-1

This Page Left Intentionally Blank



Symbols

General Information

The following symbols have been used in this manual to help communicate the intent of the instructions. When one of the symbols appears, it conveys the meaning defined below:

- WARNING - Serious personal injury or extensive property damage can result if the warning instructions are not followed.
CAUTION - Minor personal injury can result or a part, an assembly, or the engine can be damaged if the caution instructions are not followed.
Indicates a REMOVAL or DISASSEMBLY step.
Indicates an INSTALLATION or ASSEMBLY step.
INSPECTION is required.
CLEAN the part or assembly.
PERFORM a mechanical or time MEASUREMENT.
LUBRICATE the part or assembly.
Indicates that a WRENCH or TOOL SIZE will be given.
TIGHTEN to a specific torque.
PERFORM an electrical MEASUREMENT.
Refer to another location in this manual or another publication for additional information.
The component weighs 23 kg [50 lb] or more. To avoid personal injury, use a hoist or get assistance to lift the component.

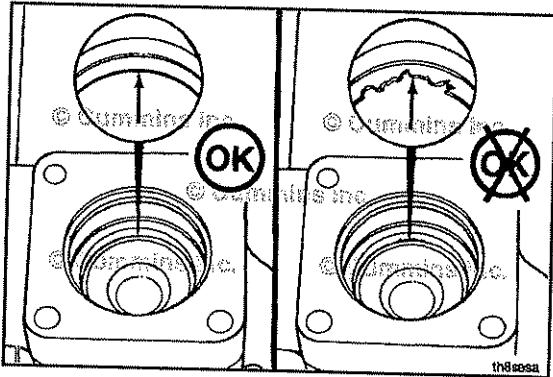

## Illustrations General Information

Some of the illustrations throughout this manual are generic and will **not** look exactly like the engine or parts used in your application. The illustrations can contain symbols to indicate an action required and an acceptable or **not** acceptable condition.

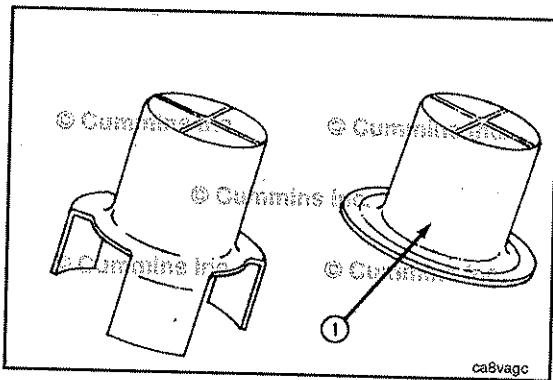

The illustrations are intended to show repair or replacement procedures. The procedure will be the same for all applications, although the illustration can differ.

General Safety Instructions

Important Safety Notice



Improper practices, carelessness, or ignoring the warnings can cause burns, cuts, mutilation, asphyxiation or other personal injury or death.

Read and understand all of the safety precautions and warnings before performing any repair. This list contains the general safety precautions that must be followed to provide personal safety. Special safety precautions are included in the procedures when they apply.

- Work in an area surrounding the product that is dry, well lit, ventilated, free from clutter, loose tools, parts, ignition sources and hazardous substances. Be aware of hazardous conditions that can exist.
• Always wear protective glasses and protective shoes when working.
• Rotating parts can cause cuts, mutilation or strangulation.
• Do not wear loose-fitting or torn clothing. Remove all jewelry when working.
• Disconnect the battery (negative [-] cable first) and discharge any capacitors before beginning any repair work. Disconnect the air starting motor if equipped to prevent accidental engine starting. Put a "Do Not Operate" tag in the operator's compartment or on the controls.
• Use ONLY the proper engine barring techniques for manually rotating the engine. Do not attempt to rotate the crankshaft by pulling or prying on the fan. This practice can cause serious personal injury, property damage, or damage to the fan blade(s) causing premature fan failure.
• If an engine has been operating and the coolant is hot, allow the engine to cool before slowly loosening the filler cap to relieve the pressure from the cooling system.
• Always use blocks or proper stands to support the product before performing any service work. Do not work on anything that is supported ONLY by lifting jacks or a hoist.
• Relieve all pressure in the air, oil, fuel, and cooling systems before any lines, fittings, or related items are removed or disconnected. Be alert for possible pressure when disconnecting any device from a system that utilizes pressure. Do not check for pressure leaks with your hand. High pressure oil or fuel can cause personal injury.
• To reduce the possibility of suffocation and frostbite, wear protective clothing and ONLY disconnect liquid refrigerant (Freon) lines in a well ventilated area. To protect the environment, liquid refrigerant systems must be properly emptied and filled using equipment that prevents the release of refrigerant gas (fluorocarbons) into the atmosphere. Federal law requires capturing and recycling refrigerant.
• To reduce the possibility of personal injury, use a hoist or get assistance when lifting components that weigh 23 kg [50 lb] or more. Make sure all lifting devices such as chains, hooks, or slings are in good condition and are of the correct capacity. Make sure hooks are positioned correctly. Always use a spreader bar when necessary. The lifting hooks must not be side-loaded.
• Corrosion inhibitor, a component of SCA and lubricating oil, contains alkali. Do not get the substance in eyes. Avoid prolonged or repeated contact with skin. Do not swallow internally. In case of contact, immediately wash skin with soap and water. In case of contact, immediately flood eyes with large amounts of water for a minimum of 15 minutes. IMMEDIATELY CALL A PHYSICIAN. KEEP OUT OF REACH OF CHILDREN.
• Naptha and Methyl Ethyl Ketone (MEK) are flammable materials and must be used with caution. Follow the manufacturer's instructions to provide complete safety when using these materials. KEEP OUT OF REACH OF CHILDREN.
• To reduce the possibility of burns, be alert for hot parts on products that have just been turned off, and hot fluids in lines, tubes, and compartments.
• Always use tools that are in good condition. Make sure you understand how to use the tools before performing any service work. Use ONLY genuine Cummins or Cummins ReCon replacement parts.
• Always use the same fastener part number (or equivalent) when replacing fasteners. Do not use a fastener of lesser quality if replacements are necessary.
• Do not perform any repair when fatigued or after consuming alcohol or drugs that can impair your functioning.
• Some state and federal agencies in the United States of America have determined that used engine oil can be carcinogenic and can cause reproductive toxicity. Avoid inhalation of vapors, ingestion, and prolonged contact with used engine oil.
• Liquefied petroleum gas is heavier than air and can accumulate near the floor, in sumps, and low-lying areas.
• Natural gas is lighter than air and can accumulate under hood and awnings.
• To reduce the possibility of suffocation and frostbite, wear protective clothing and ONLY disconnect natural gas and liquefied petroleum gas lines in a well ventilated area.
• Coolant is toxic. If not reused, dispose of in accordance with local environmental regulations.
• The catalyst reagent contains urea. Do not get the substance in your eyes. In Case of contact, immediately flood eyes with large amounts of water for a minimum of 15 minutes. Avoid prolonged contact with skin. In case of contact, immediately wash skin with soap and water. Do not swallow internally. In the event the catalyst reagent is ingested, contact a physician immediately.

- The catalyst substrate contains Vanadium Pentoxide. Vanadium Pentoxide has been determined by the State of California to cause cancer. Always wear protective gloves and eye protection when handling the catalyst assembly. Do not get the catalyst material in your eyes. In Case of contact, immediately flood eyes with large amounts of water for a minimum of 15 minutes. Avoid prolonged contact with skin. In case of contact, immediately wash skin with soap and water.
- The Catalyst substrate contains Vanadium Pentoxide. Vanadium Pentoxide has been determined by the State of California to cause cancer. In the event the catalyst is being replaced, dispose of in accordance with local regulations.

Acronyms and Abbreviations

General Information

The following list contains some of the acronyms and abbreviations used in this manual.

Table with 2 columns: Acronym and Full Name. Includes entries such as API (American Petroleum Institute), ASTM (American Society of Testing and Materials), °C (Celsius), CARB (California Air Resources Board), C.I.D. (Cubic Inch Displacement), CNG (Compressed Natural Gas), CPL (Control Parts List), cSt (Centistokes), ECM (Electronic Control Module), EGR (Exhaust Gas Recirculation), EPA (Environmental Protection Agency), °F (Fahrenheit), FMI (Failure Mode Identifier), GVW (Gross Vehicle Weight), LPG (Liquified Petroleum Gas), Hg (Mercury), hp (Horsepower), H2O (Water), ICM (Ignition Control Module), km/l (Kilometers per Liter), kPa (Kilopascal), LNG (Liquid Natural Gas), LTA (Low Temperature Aftercooling), MPa (Megapascal), mph (Miles Per Hour), mpq (Miles Per Quart), N•m (Newton-meter), NG (Natural Gas), OEM (Original Equipment Manufacturer), PID (Parameter Identification Descriptions), ppm (Parts Per Million), psi (Pounds Per Square Inch), PTO (Power Takeoff), rpm (Revolutions Per Minute), SAE (Society of Automotive Engineers), SCA (Supplemental Coolant Additive), STC (Step Timing Control), SID (Subsystem Identification Descriptions), VS (Variable Speed), and VSS (Vehicle Speed Sensor).



## Section E - Engine Identification

### Section Contents

	<b>Page</b>
<b>Engine Identification</b> .....	E-1
Cummins® Engine Nomenclature.....	E-2
Engine Dataplate.....	E-3
Fuel Injection Pump Dataplate.....	E-3
Bosch® Rotary.....	E-3
Delphi Rotary.....	E-3

This Page Left Intentionally Blank





Cummins Engine Company, Inc. Columbus, Indiana 47202-3005 Assembled in U.S.A.	CID/L	CPL	Engine Serial No.	FEL	EPA
	Family		C/S	Nox	
Warnings: Injury can result and warranty is voided if fuel rate rpm or altitudes exceed published maximum values for this model and application.	Valve lash Cold		Engine Model	Pm	
	Inch	Int. Exh	Timing -		
	MM	Int. Exh	Fuel rate at rated HP/Kw	mm3/st	
Date of MFG. 20010501 Assembled in U.S.A. 3284906	Firing Order	1 5 3 6 2 4	FR	Low Idle RPM	
	Gross Rated HP/KW		at RPM		

Have the following engine data available when communicating with a Cummins Authorized Repair Location. The information on the dataplate is **mandatory** when sourcing service parts.

00d00075

1. Control parts list (CPL)
2. Model
3. Engine serial number
4. Emissions certification
5. Horsepower and rpm rating.

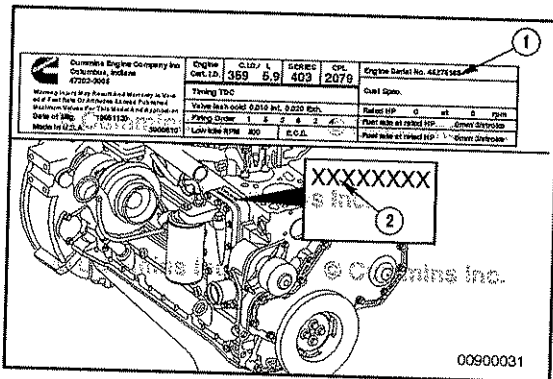

**NOTE:** If the engine dataplate (1) is **not** readable, the engine serial number (2) can be identified on the engine block near the top of the gear housing.

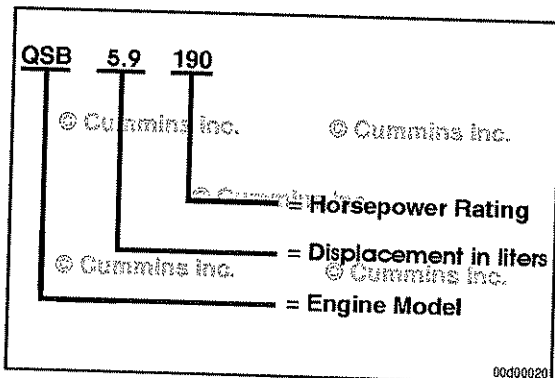

### Cummins® Engine Nomenclature

The Cummins engine nomenclature provides the data as illustrated in the graphic.

B3.9, B4.5, and B5.9 Industria [...]   
Section E - Engine Identification

**Fuel Injection Pump Dataplate**

**Bosch® Rotary**

The injection pump dataplate for the Bosch® VE pump is located on the side of the injection pump. The dataplate provides information for fuel pump calibration.

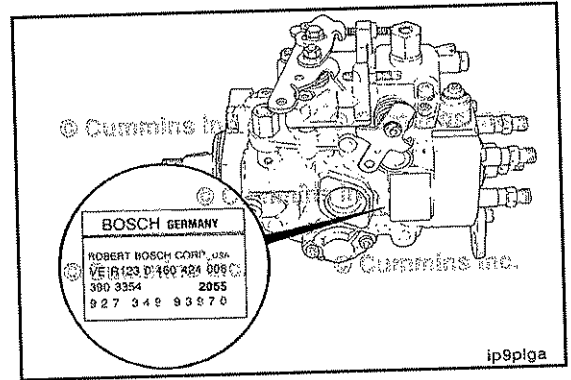

**Delphi Rotary**

The injection pump dataplate for the Delphi DP pump is located on the side of the injection pump. The dataplate provides information for fuel pump calibration.

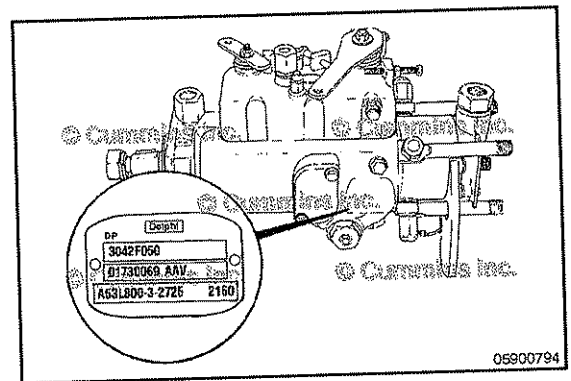



Section 1 - Operating Instructions

Section Contents

Table with 2 columns: Section Name and Page. Includes entries like Cold Weather Starting, Electromagnetic Interference (EMI), Engine Operating Range, Engine Shutdown, Normal Starting Procedure, Operating Instructions - Overview, Operating the Engine, and Starting Procedure After Extended Shutdown or Oil Change.

This Page Left Intentionally Blank

Operating Instructions - Overview
General Information



Correct care of your engine will result in longer life, better performance, and more economical operation.

Follow the daily maintenance checks listed in Maintenance Guidelines (Section 2).

The new Cummins engine associated with this manual does not require a "break-in" procedure. This section of the manual provides all of the necessary information required for proper engine operation.

Check the oil pressure indicators, temperature indicators, warning lights, and other gauges daily to make sure they are operational.

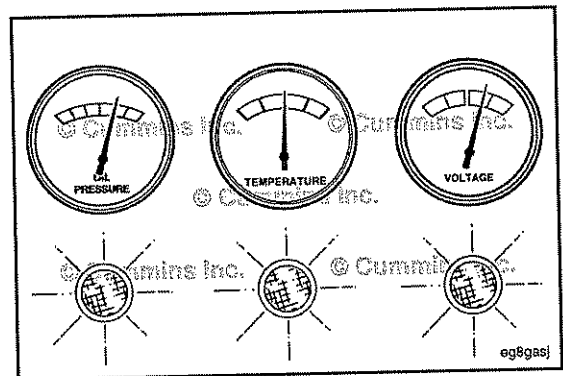

WARNING
DO NOT OPERATE A DIESEL ENGINE WHERE THERE ARE OR CAN BE COMBUSTIBLE VAPORS. The vapors can be sucked through the air intake system and cause engine acceleration and overspeeding that can result in a fire, an explosion, and extensive property damage. Numerous safety devices are available, such as air intake shutoff devices, to minimize the risk of overspeeding where an engine, due to its application, due to a fuel spill or gas leak. Remember, Cummins has no way of knowing the use you have for your engine. THE EQUIPMENT OWNER AND OPERATOR ARE RESPONSIBLE FOR SAFE OPERATION IN A HOSTILE ENVIRONMENT. CONSULT YOUR CUMMINS AUTHORIZED REPAIR LOCATION FOR FURTHER INFORMATION.

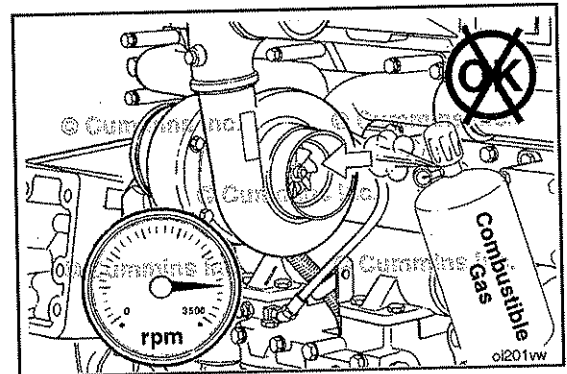

Cummins recommends the installation of an air intake shutoff device or a similar safety device to minimize the risk of overspeeding where an engine, due to the vehicle, vessel or equipment being operated in a combustible environment, such as due to a fuel spill or gas leak.

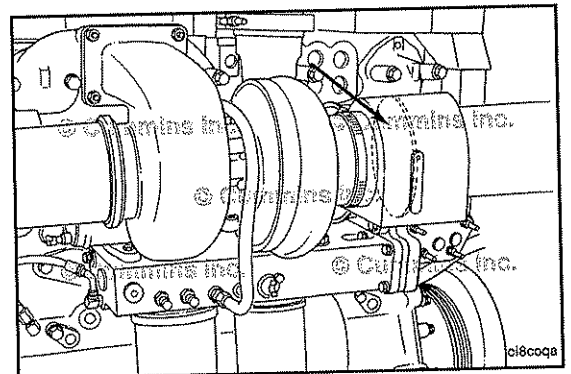

**⚠ CAUTION ⚠**

Do not expose the engine to corrosive chemicals. Corrosive chemicals can damage the engine.

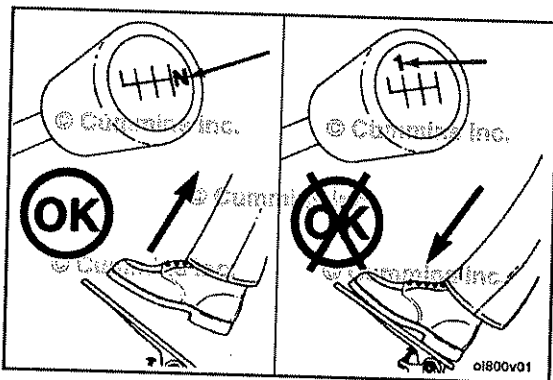

### Normal Starting Procedure General Information

**⚠ WARNING ⚠**

Do not depress the accelerator pedal or move the accelerator lever from the idle position while cranking the engine. This can result in engine overspeed and severe damage to the engine.

**⚠ CAUTION ⚠**

To prevent damage to the starting motor, do not engage the starting motor for more than 30 seconds. Wait 2 minutes between each attempt to start (electrical starting motors only).

**NOTE:** Engines equipped with air starting motors require a minimum of 480 kPa [70 psi]

1. Disengage the driven unit, or if equipped, put the transmission in neutral.
2. With the accelerator pedal or lever in the idle position, turn the keyswitch to the ON position, and wait for the WAIT-TO-START lamp to go out; then, turn the key to the START position.
3. If the engine does **not** start after three attempts, check the fuel supply system. Absence of blue or white exhaust smoke during cranking indicates no fuel is being delivered.

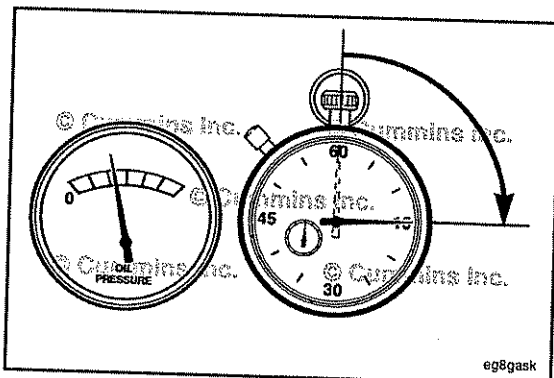

**⚠ CAUTION ⚠**

The engine must have adequate oil pressure within 15 seconds after starting. If the WARNING lamp indicating low oil pressure has not gone out or there is no oil pressure indicated on a gauge within 15 seconds, shut off the engine immediately to reduce the possibility of engine damage.

Refer to Lubricating Oil Pressure Low symptom tree in Section TS if no oil pressure is indicated.



Idle the engine 3 to 5 minutes before operating with a load.

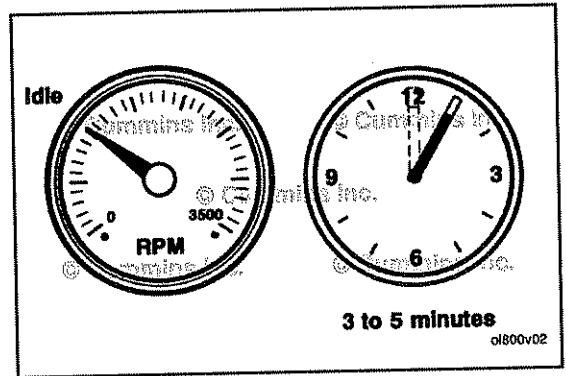

After starting a cold engine, increase the engine speed (rpm) slowly to provide adequate lubrication to the bearings and to allow the oil pressure to stabilize.

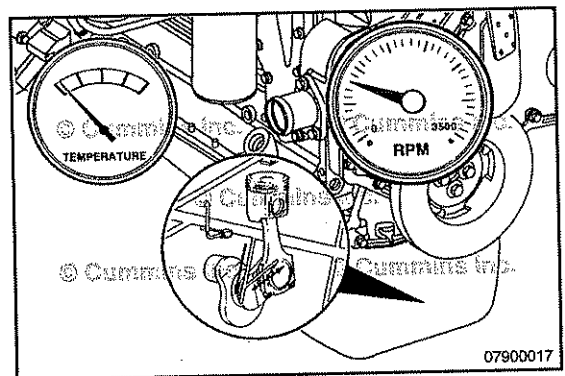

Do not operate the engine at low idle for long periods with the engine coolant temperature below the minimum specification. Refer to Engine Specifications in Section V.



This can result in the following:

- Fuel dilution of the lubricating oil
Carbon build up in the cylinder
Cylinder head valve sticking
Reduced performance.

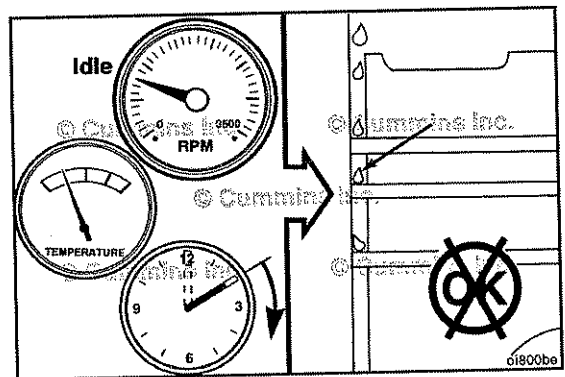

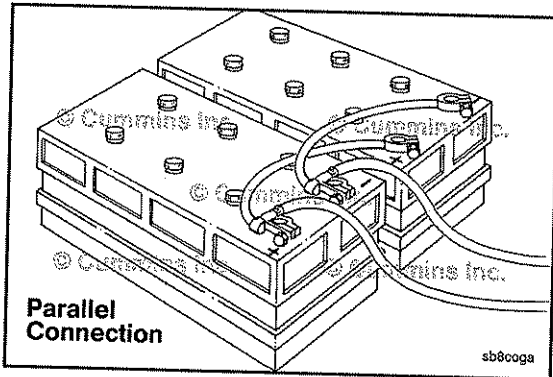

## Jump Starting

### ⚠ WARNING ⚠

Batteries can emit explosive gases. To reduce the possibility of personal injury, always ventilate the compartment before servicing the batteries. To reduce the possibility of arcing, remove the negative (-) battery cable first and attach the negative (-) battery cable last.

### ⚠ CAUTION ⚠

When using jumper cables to start the engine, make sure to connect the cables in parallel: Positive (+) to positive (+) and negative (-) to negative (-). When using an external electrical source to start the engine, turn the disconnect switch to the OFF position. Remove the key before attaching the jumper cables.

### ⚠ CAUTION ⚠

To reduce the possibility of damage to engine parts, do not connect jumper starting or battery charging cable to any fuel system or electronic component.

The accompanying illustration shows a typical parallel battery connection. This arrangement doubles the cranking amperage.

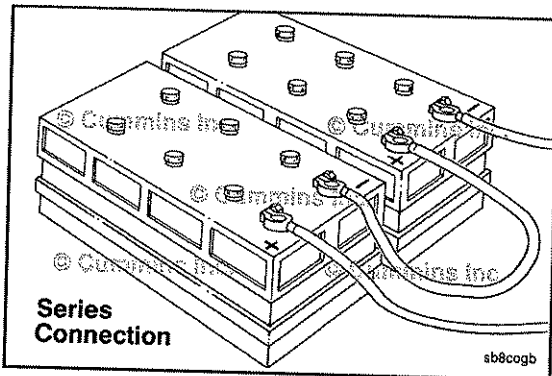

This illustration shows a typical series battery connection. This arrangement, positive (+) to negative (-), doubles the voltage.

Starting Procedure Matrix	
Automotive and industrial	Idle throttle
All pumps above 16°C [60°F]	X (after 5 seconds, see note)
Automotive and industrial	Full throttle
All pumps below 16°C [60°F]	X (see note)
(1) Full throttle on the VE pump makes sure there is sufficient start-fuel delivery and helps keep the engine operating once started. The in-line pumps with RQV and RQV-K governors require full throttle to position and hold the rack in the start-fuel position.	

**NOTE:** Full throttle is applied after engaging the starter.

1. Disengage the driven unit, or if equipped, put the transmission in neutral.
2. Position the fuel shutoff, electrical switch, or mechanism control to the RUN position.

**NOTE:** Full throttle procedure **not** required on Tier II B3.9, B4.5, and B5.9 engines.

## Cold Weather Starting

### General Information

Follow the Normal Starting Procedures in this section in cold weather. The Wait-To-Start lamp will stay on longer

### With Mechanical or Electrical Metering Equipment (Ether)

- Set the throttle at **half** speed
- Disengage the driven unit, or if equipped, put the transmission in neutral
- While cranking the engine, inject metered amounts of starting fluid
- Engine oil pressure **must** be indicated on the gauge within 15 seconds after starting.

### Ether Starting Aids



Because of the potential for an explosion, do not use volatile cold starting aids in underground mine or tunnel operations. Ask the local U.S. Bureau of Mines inspector for instructions.



Starting fluid is highly flammable and explosive. Keep flames, sparks, and arcing switches away from starting fluid.



Do not breathe starting fluid fumes. Starting fluid fumes can be hazardous to your health.



Do not use excessive amounts of starting fluid when starting an engine. The use of too much starting fluid will cause damage to the engine.

- Spray starting fluid into the air cleaner intake while another person cranks the engine.

### Grid Heater



To reduce the possibility of personal injury and property damage, never use starting fluid if the grid heater option is used. Starting fluid, which contains ether, can cause an explosion.

A grid heater is available that improves cold weather starting characteristics by heating the intake air. It can also serve to reduce white smoke if it is energized during cold ambient temperatures while the engine is at idle.

The electric grid heater operates in a preheat and postheat mode. The length of heater on-time is a function of the engine temperature.

If the engine ambient air temperature is greater than 19°C [66°F], the electric grid air heater system will **not** be activated. If the engine ambient air temperature is below 19°C [66°F], the system will operate as follows:

#### Engine Starting Cycle

1. Turn the ignition key to the RUN position. When the key is in this position, the WAIT-TO-START lamp will be illuminated for approximately 25 seconds. Do **not** crank the engine until the WAIT-TO-START lamp shuts off.

3. When the WAIT-TO-START lamp goes out, the preheat cycle is complete. Depress the accelerator pedal and crank the engine.
5. Postheating occurs as the grid heater elements are cycled for a while with the engine running. Postheating helps warm the engine up faster and eliminates white smoke. Postheating is determined by the engine ambient air temperature upon start-up.

**NOTE:** The controller is reset each time the ignition is turned off and the cycle will start over.

Postheat Cycle

## Starting Procedure After Extended Shutdown or Oil Change

### General Information

Complete the following steps after each oil change, or after the engine has been shut down for more than 30 days to make sure the engine receives the correct oil flow through the lubricating oil system.

1. Disconnect the electrical wire from the fuel pump solenoid.
2. Rotate the crankshaft, using the starting motor, until oil pressure appears on the gauge or the warning lamp goes out.
3. Connect the electrical wire to the fuel pump solenoid valve.
4. Start the engine; refer to normal starting procedures in this section.

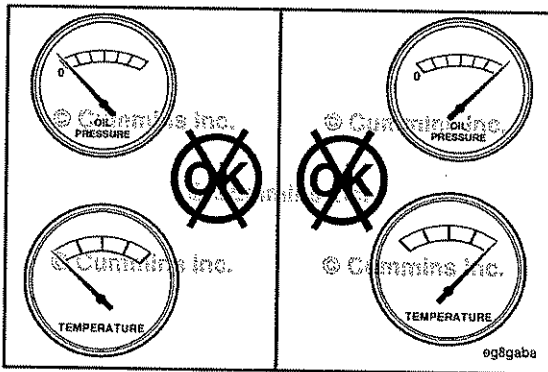

### Operating the Engine Normal

If equipped, monitor the oil pressure and coolant temperature gauges frequently. Refer to Lubricating Oil System specifications and Cooling System specifications, in Maintenance Specifications (Section V) for recommended operating pressures and temperatures. Shut off the engine if any pressure or temperature does **not** meet the specifications.

Continuous operation with engine coolant temperature above or below the engine coolant temperature specifications listed in Maintenance Specifications (Section V) can damage the engine.

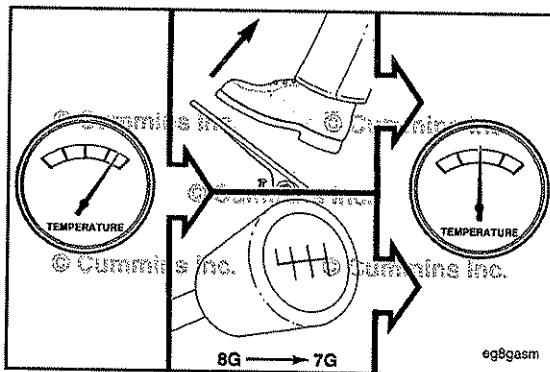

If an overheating condition starts to occur, reduce the power output of the engine by releasing the accelerator pedal or lever or shifting the transmission to a lower gear, or both, until the temperature returns to the normal operating range. If the engine temperature does **not** return to normal, shut off the engine, and refer to Troubleshooting Symptoms (Section TS), or contact a Cummins Authorized Repair Location.

Most failures give an early warning. Look and listen for changes in performance, sound, or engine appearance that can indicate service or engine repair is needed. Some changes to look for are:



- Engine misfires
• Vibration
• Unusual engine noises
• Sudden changes in engine operating temperatures or pressures
• Excessive smoke
• Loss of power
• An increase in oil consumption
• An increase in fuel consumption
• Fuel, oil, or coolant leaks.

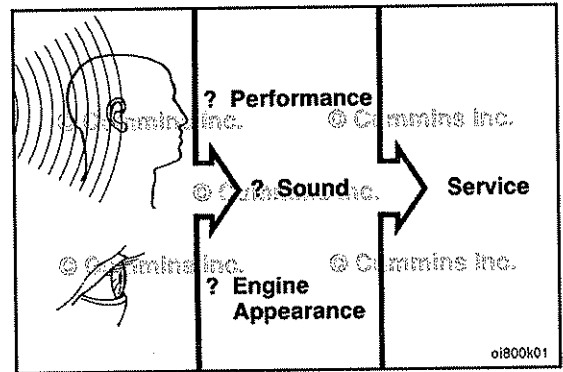

Cold Weather

It is possible to operate engines in extremely cold environments if they are properly prepared and maintained. Satisfactory performance of an engine in low ambient temperature conditions requires modification of the engine, surrounding equipment, operating practices and maintenance procedures.

The correct engine coolant lubricating oil and fuels must be used for the cold weather range in which the engine is being operated. Below are the recommendations for these critical engine fluids:

Ambient Temperature

0 to -32°C [32 to -25°F]

Use 50-percent ethylene glycol antifreeze and 50-percent water for the engine coolant mixture.

Refer to Maintenance Specifications (Section V) Lubricating Oil recommendations for the correct specifications.

The Diesel fuel must have maximum cloud and pour points 6°C [10°F] lower than the ambient temperature in which the engine operates.

-32 to -54°C [-25 to -65°F]

Use 60-percent ethylene glycol antifreeze and 40-percent water for the engine coolant mixture.

Refer to Maintenance Specifications (Section V) Lubricating Oil recommendations for the correct specifications.

The Diesel fuel must have maximum cloud and pour points 6°C [10°F] lower than the ambient temperature in which the engine operates.

The following cold weather operating aids are required for cold weather situations:

Cold Weather Operating Aids										
Temperature	Starting Aid	Coolant Heater	Oil Heater	Under-hood Air	Fuel Heater	Battery Heater	Radiator Shutters	Engine Enclosure	Winter Front	Thermostatic Fan
50 to 32° F 10 to 0° C										
32 to -10° F 0 to -23° C										Suggested
-10 to -25° F -23 to -32° C	Required	Required	Required	Required	Required	Required	Required	Required	Required	Required
-25 to -65° F -32 to -54° C	Required	Required	Required	Required	Required	Required	Required	Required	Required	Required

\* Required dependent upon viscosity/pour point.

oi202vj

### Winterfronts and Shutters

Winterfronts and shutters can be used on a vehicle or equipment to reduce air flow through the radiator core into the engine compartment. This can reduce the time required to warm the engine and help maintain the engine coolant temperature. The engine coolant temperature specifications are in the Maintenance Specification (Section V).

B3.9, B4.5, and B5.9 Industria [...] Section 1 - Operating Instructions

## Engine Operating Range General Information

### ⚠ CAUTION ⚠

Do not operate the engine at full throttle operation below peak torque rpm (refer to engine dataplate for peak torque rpm) for more than 30 seconds. Operating the engine at full throttle below peak torque will shorten engine life to overhaul, can cause serious engine damage, and is considered engine abuse.

Cummins engines are designed to operate successfully at full throttle under transient conditions down to peak torque engine speed. This is consistent with recommended operating practices.

### ⚠ CAUTION ⚠

Do not operate the engine beyond the maximum engine speed. Operating the engine beyond the maximum engine speed can cause severe engine damage. Use proper operating techniques for the vehicle, vessel, or equipment to prevent engine overspeed. The maximum engine speed specification is listed in Maintenance Specifications (Section V).

## Engine Shutdown General Information

Allow the engine to idle 3 to 5 minutes before shutting it off after a full-load operation. This allows adequate cool down of pistons, cylinders, bearings, and turbocharger components.

Turn the ignition switch to the OFF position. If the engine does not shut down, refer to Troubleshooting Symptom (Section TS).

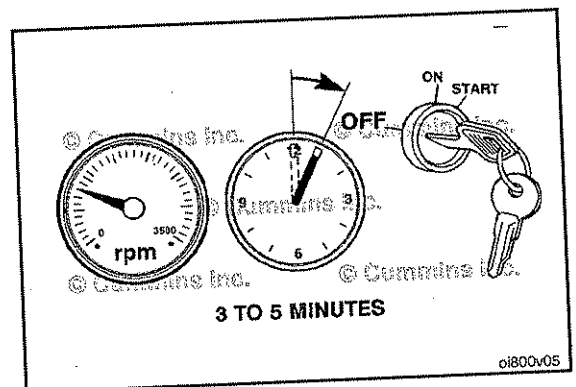
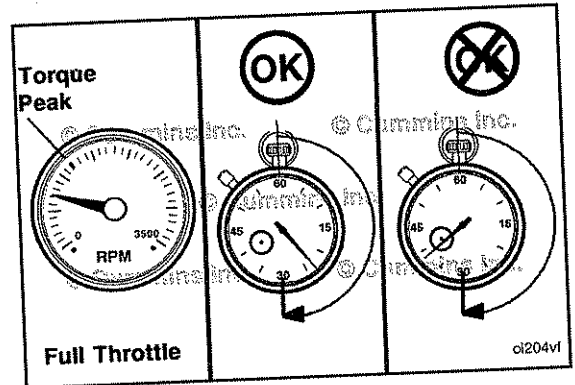

## Electromagnetic Interference (EMI)

### General Information

Some engine applications utilize accessories (CB radios, mobile transmitters, etc.) that generate and use radio frequency energy that, if **not** installed and used properly, can cause electromagnetic interference (EMI) conditions to exist between the accessory and Cummins electronic controlled fuel system. Cummins is **not** liable for any performance problems with either the fuel system or the accessory due to EMI. EMI is **not** considered by Cummins to be an engine failure and therefore is **not** warrantable.

### System EMI Susceptibility

Your Cummins product has been designed and tested for minimum sensitivity to incoming electromagnetic energy. Testing has shown that there is no engine performance degradation at relatively high energy levels; however, if very high energy levels are encountered, then some noncritical diagnostic fault code logging can occur. The fuel system EMI susceptibility level will protect your engine from most, if **not** all, electromagnetic energy-emitting devices that meet the Federal Communications Commission legal requirements.

### System EMI Radiation Levels

Your Cummins product has been designed to emit minimum electromagnetic energy. Electronic components are required to pass various Cummins and industry EMI specifications. Testing has shown that when the engine is properly

installed, it will not interfere with onboard communication equipment or with the vehicle's, equipment's, or vessel's ability to meet any applicable EMI standards and regulated specifications.

If an interference condition is observed, follow the suggestions below to reduce the amount of interference:

1. Locate the receiving antenna as far away from the engine and as high as possible.
2. Locate the receiving antenna as far away as possible from all metal obstructions (e.g., exhaust stacks)
3. Consult a representative of the accessory supplier in your area to:
  - Calibrate accurately the device for proper frequency, power output, and sensitivity (both base and remote site devices **must** be properly calibrated)
  - Obtain antenna reflective energy data measurements to determine the optimum antenna location
  - Obtain optimum antenna type and mounting arrangement for your application
  - Make sure your accessory equipment model is built for maximum filtering to reject incoming electromagnetic noise.



## Section 2 - Maintenance Guidelines

### Section Contents

	Page
<b>Maintenance Guidelines - Overview</b> .....	2-1
General Information.....	2-1
<b>Maintenance Record Form</b> .....	2-4
Maintenance Data.....	2-4
<b>Maintenance Schedule</b> .....	2-2
General Information.....	2-2
Oil Drain Intervals.....	2-2

This Page Left Intentionally Blank

## Maintenance Guidelines - Overview

### General Information

Cummins Inc. recommends that the engine be maintained according to the Maintenance Schedule in this section.

If the engine is operating in ambient temperatures below  $-18^{\circ}\text{C}$  [ $0^{\circ}\text{F}$ ] or above  $38^{\circ}\text{C}$  [ $100^{\circ}\text{F}$ ], perform maintenance at shorter intervals. Shorter maintenance intervals are also required if the engine is operated in a dusty environment or if frequent stops are made. Contact your local Cummins Authorized Repair Location for recommended maintenance intervals.

Some of these maintenance procedures require special tools or must be completed by qualified personnel. Contact your local Cummins Authorized Repair Location for detailed information.

If your engine is equipped with a component or accessory not manufactured by Cummins Inc., refer to the component manufacturer's maintenance recommendations.

Use the chart provided in this section as a convenient way to record maintenance performed.

## Maintenance Schedule

### General Information

Perform maintenance at whichever interval that occurs first. At each scheduled maintenance interval, perform all previous maintenance checks that are due for scheduled maintenance.

#### Daily or Refueling - Maintenance Check<sup>(4)</sup>

- Air Intake Piping - Inspect
- Air Tank and Reservoirs - Drain
- Cooling Fan - Check/Correct
- Crankcase Breather Tube - Inspect
- Drive Belts - Check/Correct
- Engine Coolant Level - Check/Correct
- Engine Lubricating Oil Level - Check/Correct
- Fuel-Water Separator - Drain
- Vibration Damper - Inspect

#### Every 250 Hours or 3 Months - Maintenance Check (1, 4)

- Air Cleaner Restriction - Check/Correct
- Air Compressor Mounting Hardware - Check/Correct
- Charge Air Cooler - Check/Correct
- Charge Air Piping - Check/Correct
- Fuel Injection Pump Mounting Hardware - Check/Correct
- Lubricating Oil and Filters - Change
- Radiator Hoses - Check

#### Every 500 Hours or 6 Months - Maintenance Check (2, 3, 4)

- Engine Coolant - Antifreeze Check
- Fuel Filter, Canister-Type - Replace
- Fuel Filter, Spin-on-Type - Replace
- Lubricating Oil and Filters - Change

#### Every 1000 Hours or 1 Year - Maintenance Check<sup>(4)</sup>

- Cooling Fan Belt Tensioner - Check/Correct
- Fan Hub, Belt-Driven - Check/Correct
- Overhead Set - Adjust

#### Every 2000 Hours or 2 Years - Maintenance Check (3, 4)

- Air Compressor Discharge Line - Check/Correct
- Cooling System - Drain, Flush, and Fill
- Vibration Damper, Rubber - Check
- Vibration Damper, Viscous - Check

#### Notes:

1. The lubricating oil and lubricating oil filter interval can be adjusted based on application, fuel consumption, gross vehicle weight, and idle time. For engines whose aspiration is jacket water-cooled, turbocharged **only**, or natural, refer to Table 1 in the Oil Drain Intervals section.
2. The lubricating oil and lubricating oil filter interval can be adjusted based on application, fuel consumption, gross vehicle weight, and idle time. For engines whose aspiration is charge air cooled, refer to Table 2 in the Oil Drain Intervals section.
3. Antifreeze check interval is every oil change or 500 hours or 6 months, whichever occurs first. The operator **must** use a heavy-duty year-round antifreeze that meets the chemical composition of GM6038M. The antifreeze change interval is 2 years, 2000 hours, or whichever occurs first. Antifreeze is essential for freeze, overheat, and corrosion protection.
4. Follow the manufacturer's recommended maintenance procedures for the starter, alternator, generator, batteries, electrical components, charge air cooler, radiator, air compressor, air cleaner, refrigerant compressor, and fan clutch. Refer to the Component Manufacturers in Section M.

### Oil Drain Intervals

Refer to Table 1 or Table 2 to determine the maximum recommended oil change and filter change intervals engine operating in hours or months, whichever comes first.

Table 1: Jacket Water Cooled, Turbocharged Only, or Naturally Aspirated Engines			
Cummins Engine Standard Classification	American Petroleum Institute Classification	International Classifications	All Engine Ratings
(CES)	(API)		

<b>Table 1: Jacket Water Cooled, Turbocharged Only, or Naturally Aspirated Engines</b>			
<b>Cummins Engine Standard Classification</b>	<b>American Petroleum Institute Classification</b>	<b>International Classifications</b>	<b>All Engine Ratings</b>
CES-20078, CES-20077, CES-20076, CES-20072, CES-20071	API CI-4/SK, API CI-4, API CH-4, API CH-4/SJ	ACEA E-5, Global DHD-1	250 Hours or 3 Months
CES-20075	API CF-4/SG	ACEA E-3, ACEA E-2, JAMA DH-1	150 Hours or 6 Weeks
	API CG-4/SH, API CD, API CE	ACEA E-1	Obsolete. Donot use.

<b>Table 2: Charge Air Cooled Engines</b>			
<b>Cummins Engine Standard Classification</b>	<b>American Petroleum Institute Classification</b>	<b>International Classifications</b>	<b>All Engine Ratings</b>
(CES)	(API)		
CES-20078, CES-20077, CES-20076, CES-20072, CES-20071	API CI-4/SK, API CI-4, API CH-4, API CH-4/SJ	ACEA E-5, Global DHD-1	500 Hours or 6 Months
CES-20075	API CF-4/SG	ACEA E-3, ACEA E-2, JAMA DH-1	250 Hours or 3 Weeks
	API CG-4/SH, API CD, API CE	ACEA E-1	Obsolete. Donot use.



## Section L - Service Literature

### Section Contents

	Page
<b>Additional Service Literature</b> .....	L-1
General Information.....	L-1
<b>Cummins Customized Parts Catalog</b> .....	L-3
General Information.....	L-3
Ordering the Customized Parts Catalog.....	L-3
Ordering by Telephone.....	L-3
Ordering On-Line.....	L-3
<b>Service Literature Ordering Location</b> .....	L-2
Contact Information.....	L-2

This Page Left Intentionally Blank



## Additional Service Literature

### General Information

The following publications can be purchased by contacting your Cummins distributor:

<b>Bulletin</b>	<b>Title of Publication</b>
3666087	Troubleshooting and Repair Manual, B3.9 and B5.9 Series Engines
3666017	B Series Shop Manual
3666109	Alternative Repair Manual, B and C Series Engines
3379000	Air For Your Engine
3666132	Coolant Requirements and Maintenance
3810340	Cummins Engine Oil Recommendations
3379001	Fuels for Cummins Engines
3379009	Operation - Cold Weather

## Service Literature Ordering Location Contact Information

Region	Ordering Location
United States and Canada	Cummins Distributors or Credit Cards at 1-800-646-5609 or Order online at <a href="http://www.powerstore.cummins.com">www.powerstore.cummins.com</a>
U.K., Europe, Mid-East, Africa, and Eastern European Countries	Cummins Engine Co., Ltd. Royal Oak Way South Daventry Northants, NN11 5NU, England
South and Central America (excluding Brazil and Mexico)	Cummins Americas, Inc. 16085 N.W. 52nd Avenue Hialeah, FL 33104
Brazil and Mexico	Cummins Inc. International Parts Order Dept., MC 40931 Box 3005 Columbus, IN 47202-3005
Far East (excluding Australia and New Zealand)	Cummins Diesel Sales Corp. Literature Center 8 Tanjong Penjuru Jurong Industrial Estate Singapore
Australia and New Zealand	Cummins Diesel Australia Maroondah Highway, P.O.B. 139 Ringwood 3134 Victoria, Australia

## Cummins Customized Parts Catalog

### General Information

Cummins is pleased to announce the availability of a parts catalog compiled specifically for you. Unlike the generic versions of parts catalogs that support general high volume parts content; Cummins Customized catalogs contains only the new factory parts that were used to build your engine.

The catalog cover, as well as the content, is customized with you in mind. You can use it in your shop, at your worksite, or as a coffee table book in your RV or boat. The cover contains your name, company name, address, and telephone number. Your name and engine model identification even appears on the catalog spine. Everybody will know that Cummins created a catalog specifically for you.

This new catalog was designed to provide you with the exact information you need to order parts for your engine. This will be valuable for customers that do not have easy access to the Cummins Electronic Parts Catalog or the Cummins Parts Microfilm System.

Additional Features of the Customized Catalog include:

- Engine Configuration Data
- Table of Contents
- Separate Option and Parts Indexes
- Service Kits (when applicable)
- ReCon Part Numbers (when applicable)

### Ordering the Customized Parts Catalog

#### Ordering by Telephone

North American customers can contact their Cummins Distributor or call Gannett Direct Marketing Services at 1-800-646-5609 and order by credit card. Outside North America order on-line or make an International call to Gannett at (+ +)502-454-6660.

#### Ordering On-Line

The Customized Parts Catalog can be ordered On-Line from the Cummins Powerstore by credit card. Contact the Powerstore at [WWW.POWERSTORE.CUMMINS.COM](http://WWW.POWERSTORE.CUMMINS.COM)

Contact GDMS or the CUMMINS POWERSTORE for the current price; Freight may be an additional expense.

Information we need to take your Customized Parts Catalog Order. This information drives the cover content of the CPC.

- Customer Name
- Street Address
- Company Name (optional)
- Telephone no.
- Credit Card No.
- Cummins Engine Serial Number (located on the engine data plate)
- Please identify the required media: Printed Catalog, CD-ROM, or PDF File

Unfortunately not all Cummins Engines can be supported by this parts catalog. Engines older than 1984 or newer than 3 months may not have the necessary parts information to compile a catalog. We will contact you if this occurs and explain why we are unable to fill your order.

Customized Parts Catalogs are produced specifically for a single customer. This means they are not returnable for a refund. If we make an error and your catalog is not useable, we will correct that error by sending you a new catalog.



Section V - Maintenance Specifications

Section Contents

Table with 2 columns: Section Name and Page. Includes entries like Coolant Recommendations and Specifications (V-6), Cummins/Fleetguard Filter Specifications (V-2), Fuel Recommendations and Specifications (V-3), General Engine (V-1), and Lubricating Oil Recommendations and Specifications (V-4).

This Page Left Intentionally Blank

General Engine

Specifications

Table with 2 columns: Specification Name and Value. Rows include Horsepower (Refer to engine dataplate), Engine Weight (Dry) Less Flywheel and Electronics (B4.5: 326 kg [721 lb], B4.5 and B3.9 (turbocharged): 338 kg [745 lb], B5.9: 432 kg [952 lb]), Compression Ratio (18:1), Bore (B3.9, B4.5, and B5.9: 102 mm [4.02 in]), Stroke (B4.5: 138 mm [5.42 in], B3.9 and B5.9: 120 mm [4.72 in]), Displacement (B3.9: 3.9 liters [238 C.I.D.], B4.5: 4.5 liters [275 C.I.D.], B5.9: 5.9 liters [359 C.I.D.]), Firing Order (B3.9 and B4.5: 1-3-4-2, B5.9: 1-5-3-6-2-4), Valve Clearance (Intake: 0.25 mm [0.010 in], Exhaust: 0.51 mm [0.020 in]), and Crankshaft Rotation (viewed from the front of the engine): Clockwise.

## Cummins/Fleetguard® Filter Specifications

### General Information

Fleetguard® is a subsidiary of Cummins Inc. Fleetguard® filters are developed through joint testing at Cummins and Fleetguard®. Fleetguard® filters are standard on new Cummins engines. Cummins Inc. recommends their use.

Fleetguard® products meet all Cummins Source Approval Test standards to provide the quality filtration necessary to achieve the engine's design life. If other brands are substituted, the purchaser should insist on products that the supplier has tested to meet Cummins high-quality standards.

Cummins can **not** be responsible for problems caused by nongenuine filters that do **not** meet Cummins performance or durability requirements.

Filter Part Numbers						
	Lubricating Oil Filter B3.9	Lubricating Oil Filter B4.5	Lubricating Oil Filter B5.9	Fuel Filter B3.9	Fuel Filter B4.5	Fuel Filter B5.9
<b>Cummins Part Number</b>	3934429	3934429	3934430	3966139	3991350	3900632
Fleetguard® Part Number	LF9100	LF9100	LF9098	FF9413	FS19608	FF9417



## Fuel Recommendations and Specifications

### Fuel Recommendations

#### ⚠ WARNING ⚠

Do not mix gasoline, alcohol, or gasohol with diesel fuel. This mixture can cause an explosion.

#### ⚠ CAUTION ⚠

Due to the precise tolerances of diesel injection systems, it is extremely important that the fuel be kept clean and free of dirt or water. Dirt or water in the system can cause severe damage to both the fuel pump and the fuel injectors.

Cummins Inc. recommends the use of ASTM number 2D fuel. The use of number 2 diesel fuel will result in optimum engine performance.

At operating temperatures below 0°C [32°F], acceptable performance can be obtained by using blends of number 2D and number 1D.

**NOTE:** Lighter fuels can reduce fuel economy.

**NOTE:** Engines equipped with diesel particulate filters require the use of diesel fuel with 30 ppm sulfur maximum. There are no acceptable substitutes.

The viscosity of the fuel **must** be kept above 1.3 cSt at 40°C [104°F] to provide adequate pumping and lubricating characteristics to fuel system components.

The following chart lists acceptable substitute fuels for this engine.

Acceptable Substitute Fuels									
Number 1D Diesel <sup>(1)</sup> (2) (3)	Number 2D Diesel <sup>(3)</sup>	Number 1K Kerosene	Jet-A	Jet-A1	JP-5	JP-8	Jet-B	JP-4	CITE
A	OK	Not OK	A	A	A	A	Not OK	Not OK	Not OK
<ul style="list-style-type: none"> <li>An "A" means OK <b>only</b> if fuel lubricity is adequate. This means the BOCLE number is 3100 or greater as measured by ASTM specification D6078, Scuffing Load Ball On Cylinder Evaluator (SLBOCLE). Lubricity can also be measured by ASTM, specification D6079, ISO 12156, High Frequency Reciporating Rig (HFRR) in which the fuel <b>must</b> have a wear scar diameter of 0.45 mm [0.02 in] or less.</li> <li>Any adjustment to compensate for reduced performance with a fuel system using alternate fuel is <b>not</b> warrantable.</li> <li>Winter blend fuels, such as found at commercial fuel-dispensing outlets, are combinations of number 1D and 2D diesel fuels and are acceptable.</li> </ul>									

Additional information for fuel recommendations and specifications can be found in Fuel for Cummins Engines, Bulletin 3379001. See ordering information in the back of this manual.

## Lubricating Oil Recommendations and Specifications

### General Information

#### ⚠ CAUTION ⚠

A sulfated ash limit of 1.85 percent has been placed on all engine lubricating oils recommended for use in Cummins engines. Higher ash oils can cause valve and/or piston damage and lead to excessive oil consumption.

The use of quality engine lubricating oils, combined with appropriate oil drain and filter change intervals, is a critical factor in maintaining engine performance and durability.

Cummins Inc. recommends the use of high-quality SAE 15W-40 heavy-duty engine oil, such as Valvoline® Premium Blue®, which meets performance specifications as listed below.

**NOTE:** In areas where CH-4/SJ or CG-4/SH oils are **not** available, refer to Oil Drain Intervals in Section 2.

Cummins Engineering Standard Classification (CES)	American Petroleum Institute Classification (API)	International Classifications	Comments
	API CD API CE API CG-4/SH	ACEA E-1	<b>OBSELETE. DO NOT USE.</b>
CES-20075	API CF-4/SG	ACEA E-2 ACEA E-3 JAMA DH-1	Minimum acceptable oil classification for midrange engines.
CES-20071 CES-20076	API CH-4/SJ API CH-4	Global DHD-1	Acceptable oil classification for midrange engines.
CES-20072 CES-20077	API CH-4	ACEA E-5 Global DHD-1	Similar in performance to CES-20071 but validated under European test standards. Excellent oil for midrange engines.
CES-20078	API CI-4/SK API CI-4		Excellent oil for midrange engines.

A sulfated ash limit of 1.0 mass percent is suggested for optimum valve and piston deposit and oil consumption control. For further details and discussion of engine lubricating oils for Cummins engines, refer to Cummins Engine Oil Recommendations, Bulletin 3810340.

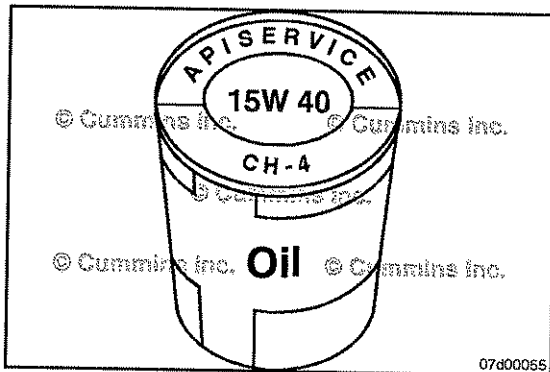

The API service symbols are shown in the accompanying illustration. The upper half of the symbols displays the appropriate oil categories.

The lower half can contain words to describe oil energy-conserving features.

The center section identifies the SAE oil viscosity grade.

As the engine oil becomes contaminated, essential oil additives are depleted. Lubricating oils protect the engine as long as these additives are functioning properly. Progressive contamination of the oil between oil and filter change intervals is normal. The amount of contamination will vary depending on the operation of the engine, kilometers or miles on the oil, fuel consumed, and new oil added.

Extending oil and filter change intervals beyond the recommendations will decrease engine life due to factors such as corrosion, deposits, and wear.

Refer to the oil drain chart in this section to determine which oil drain interval to use for your application.

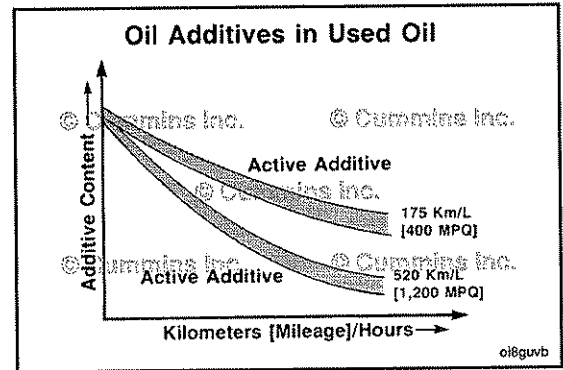

### New Engine Break-in Oils

Special "break-in" engine lubricating oils are **not** recommended for new or rebuilt Cummins engines. Use the same type of oil during the break-in as is used in normal operation.

Additional information regarding lubricating oil availability throughout the world is available in the EMA Lubricating Oils Data Book for Heavy-Duty Automotive and Industrial Engines. The data book can be ordered from the Engine Manufacturers Association, Two North LaSalle Street - Suite 2200, Chicago, IL, U.S.A. 60602. The telephone number is (312) 827-8733.

### Arctic Operation



The use of a synthetic-base oil does not justify extended oil change intervals. Extended oil change intervals can decrease engine life due to factors such as corrosion, deposits, and wear.

The use of low-viscosity oils, such as 10W or 10W-30, can be used to aid in starting the engine and in providing sufficient oil flow at ambient temperatures below -5°C [23° F]. However, continuous use of low-viscosity oils can decrease engine life due to wear. Refer to the accompanying chart.

If an engine is operated in ambient temperatures consistently below -23°C [-9°F] and there are no provisions to keep the engine warm when it is **not** in operation, use a synthetic CH/SI or CH/SK or higher API classification engine oil with adequate low-temperature properties such as 5W-20 or 5W-30.

The oil supplier is responsible for meeting the performance service specifications represented with its product.

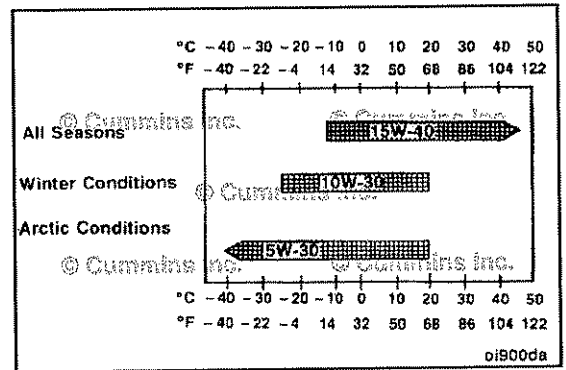

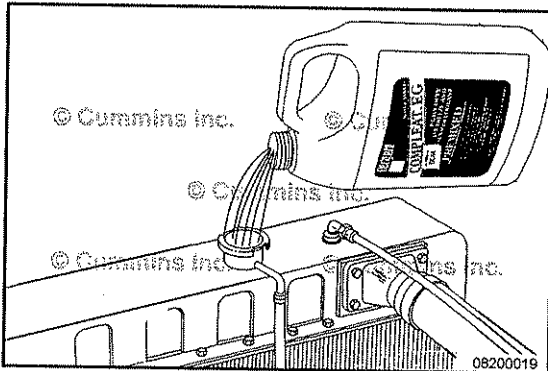

## Coolant Recommendations and Specifications

### Fully Formulated Coolant/Antifreeze

Use low-silicate antifreeze that meets ASTM4985 (GM6038M specification) criteria.

Fully formulated coolant **must** meet ASTM D-6210/D-6211.

Cummins Inc. recommends using either a 50/50 mixture of good-quality water and fully formulated antifreeze, or fully formulated coolant when filling the cooling system.

Good-quality water is important for cooling system performance. Excessive levels of calcium and magnesium contribute to scaling problems, and excessive levels of chlorides and sulfates cause cooling system corrosion.

Water Quality	
Calcium Magnesium (hardness)	Maximum 170 ppm as (CaCO <sub>3</sub> + MgCO <sub>3</sub> )
Chloride	40 ppm as (Cl)
Sulfur	100 ppm as (SO <sub>4</sub> )

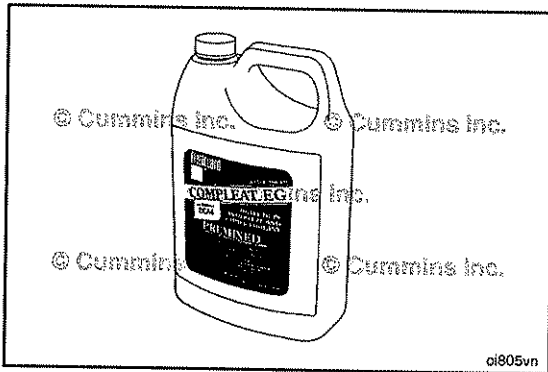

Cummins Inc. recommends using Fleetguard® Compleat. It is available in both glycol forms (ethylene and propylene).

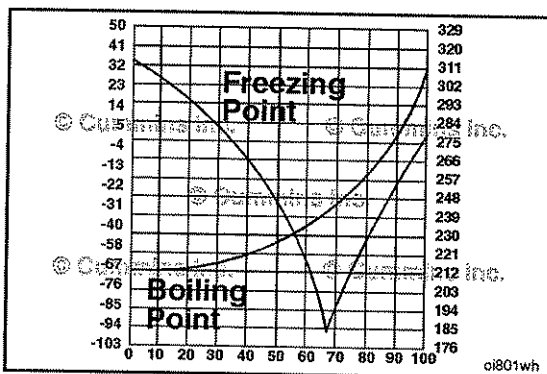

Fully formulated antifreeze **must** be mixed with good-quality water at a 50/50 ratio (40- to 60-percent working range). A 50/50 mixture of antifreeze and water gives a -36°C [-33°F] freezing point and a 108°C [226°F] boiling point, which is adequate for locations in North America. The actual lowest freezing point of ethylene glycol antifreeze is at 68 percent. Using higher concentrations of antifreeze will raise the freezing point of the solution and increase the possibility of a silica gel problem.

**B3.9, B4.5, and B5.9 Industria [...]  
Section V - Maintenance Specifications**

A refractometer **must** be used to measure the freezing point of the coolant **accurately**. Use Fleetguard® refractometer, Part Number C2800.

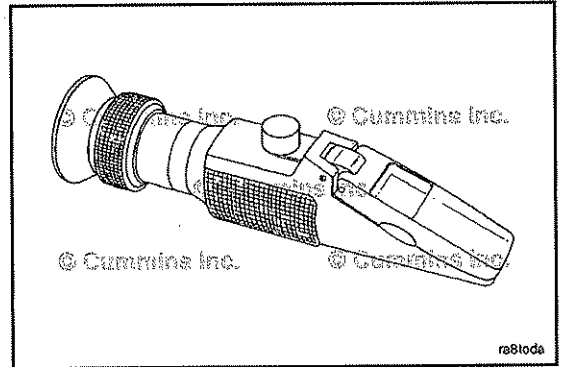

Do **not** use a floating ball hydrometer. Using floating ball hydrometers can give an incorrect reading.

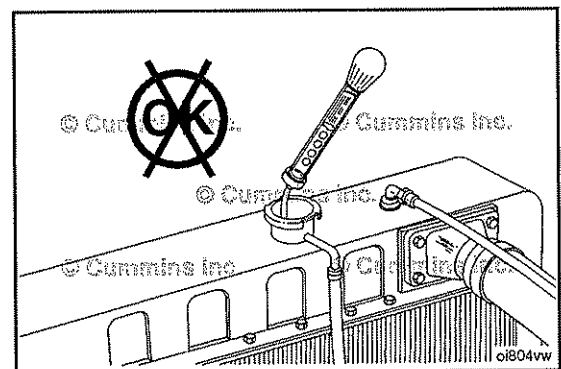

**Cooling System Sealing Additives**

Do **not** use sealing additives in the cooling system. The use of sealing additives will:

- Buildup in coolant low-flow areas
- Plug the radiator and oil cooler
- Possibly damage the water pump seal.

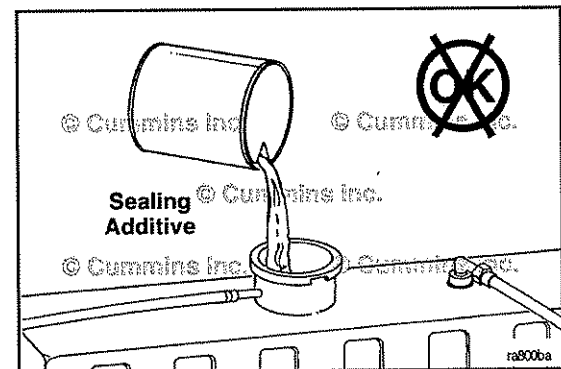

**Cooling System Soluble Oils**

Do **not** use soluble oils in the cooling system. The use of soluble oils will:

- Corrode brass and copper
- Damage heat transfer surfaces
- Damage seals and hoses.

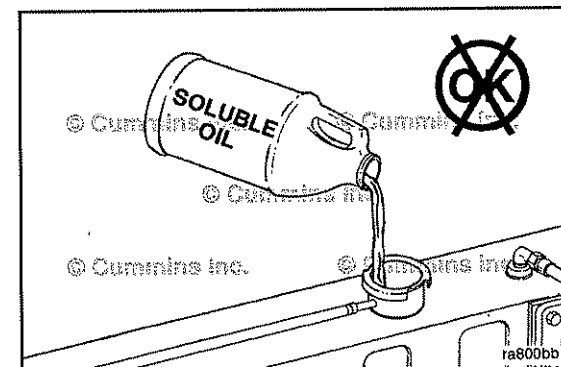



Section W - Warranty

Section Contents

Table with 2 columns: Description and Page. Rows include California Emission Control System Warranty, Off-Highway (W-6), All Engines International Industrial (Off-Highway) (W-4), and All Engines United States and Canada Industrial (Off-Highway) (W-1).

This Page Left Intentionally Blank



All Engines United States and Canada Industrial (Off-Highway)

Coverage

Products Warranted

This warranty applies to new Engines sold by Cummins and delivered to the first user on or after April 1, 1999, that are used in industrial (off-highway) applications in the United States\* and Canada, except for Engines used in marine, generator drive and certain defense applications, for which different warranty coverage is provided.

Base Engine Warranty

This warranty covers any failures of the Engine, under normal use and service, which result from a defect in material or factory workmanship (Warrantable Failures).

Coverage begins with the sale of the Engine by Cummins. Coverage continues for two years or 2,000 hours of operation, whichever occurs first, from the date of delivery of the Engine to the first user, or from the date the unit is first leased, rented or loaned, or when the Engine has been operated for 50 hours, whichever occurs first. If the 2,000 hour limit is exceeded during the first year, Coverage continues until the end of the first year.

Extended Major Components Warranty

The Extended Major Components Warranty covers Warrantable Failures of the Engine cylinder block, camshaft, crankshaft and connecting rods (Covered Parts).

Bushing and bearing failures are not covered.

This Coverage begins with the expiration of the Base Engine Warranty and ends three years or 10,000\* hours of operation from the date of delivery of the Engine to the first user, or from the date the unit is first leased, rented or loaned, or from when the Engine has been operated for 50 hours, whichever occurs first.

\*3,000 hours for A series engines.

Consumer Products

The warranty on Consumer Products in the United States is a LIMITED warranty. CUMMINS IS NOT RESPONSIBLE FOR INCIDENTAL OR CONSEQUENTIAL DAMAGES. Any implied warranties applicable to Consumer Products in the United States terminate concurrently with the expiration of the express warranties applicable to the product. In the United States, some states do not allow the exclusion of incidental or consequential damages, or limitations on how long an implied warranty lasts, so the limitations or exclusions herein may not apply to you.

These warranties are made to all Owners in the chain of distribution, and Coverage continues to all subsequent Owners until the end of the periods of Coverage.

Cummins' Responsibilities

During The Base Engine Warranty

Cummins will pay for all parts and labor needed to repair the damage to the Engine resulting from a Warrantable Failure.

Cummins will pay for the lubricating oil, antifreeze, filter elements, and other maintenance items that are not reusable due to the Warrantable Failure.

Cummins will pay reasonable costs for mechanics to travel to and from the equipment site, including meals, mileage and lodging, when the repair is performed at the site of the failure.

Cummins will pay reasonable labor costs for Engine removal and reinstallation when necessary to repair a Warrantable Failure.

During The Extended Major Components Warranty

Cummins will pay for the repair or, at its option, replacement of the defective Covered Part and any Covered Part damaged by a Warrantable Failure of the defective Covered part.

Owner's Responsibilities

During The Base Engine Warranty

Owner is responsible for the cost of lubricating oil, antifreeze, filter elements and other maintenance items provided during warranty repairs unless such items are not reusable due to the Warrantable Failure.

During The Extended Major Components Warranty

Owner is responsible for the cost of all labor needed to repair the Engine, including the labor to remove and reinstall the Engine. When Cummins elects to repair a part instead of replacing it, Owner is not responsible for the labor needed to repair the part.

Owner is responsible for the cost of all parts required for the repair except for the defective Covered Part and any Covered Part damaged by a Warrantable Failure of the defective Covered Part.

Owner is responsible for the cost of lubricating oil, antifreeze, filter elements and other maintenance items replaced during repair of a Warrantable Failure.

### **During The Base Engine and Extended Major Components Warranties**

Owner is responsible for the operation and maintenance of the Engine as specified in the applicable Cummins Operation and Maintenance Manual. Owner is also responsible for providing proof that all recommended maintenance has been performed.

Before the expiration of the applicable warranty, Owner must notify a Cummins distributor, authorized dealer or other repair location approved by Cummins of any Warrantable Failure and make the Engine available for repair by such facility. Locations in the United States and Canada are listed in the Cummins Off Highway Authorized Dealer Directory.

Owner is responsible for communication expenses, meals, lodging and similar costs incurred as a result of a Warrantable Failure.

Owner is responsible for non-Engine repairs, "downtime" expenses, cargo damage, fines, all applicable taxes, all business costs and other losses resulting from a Warrantable Failure.

### **Limitations**

Cummins is not responsible for failures or damage resulting from what Cummins determines to be abuse or neglect, including, but not limited to: operation without adequate coolants or lubricants; overfueling; overspeeding; lack of maintenance of lubricating, cooling or intake systems; improper storage, starting, warm-up, run-in or shutdown practices; unauthorized modifications of the Engine. Cummins is also not responsible for failures caused by incorrect oil or fuel or by water, dirt or other contaminants in the fuel or oil.

For power units and fire pumps (package units), this warranty applies to accessories, except for clutches and filters, supplied by Cummins which bear the name of another company.

Except for power units and fire pumps, this warranty does not apply to accessories which bear the name of another company. Such non-warranted accessories include, but are not limited to: alternators, starters, fans\*\*, air conditioning compressors, clutches, filters, transmissions, torque converters, steering pumps, and non-Cummins fan drives, engine compression brakes and air compressors.

Cummins Compusave units are covered by a separate warranty.

Before a claim for excessive oil consumption will be considered, Owner must submit adequate documentation to show that consumption exceeds Cummins published standards.

Failures of belts and hoses supplied by Cummins are not covered beyond the first 500 hours or one year of operation, whichever occurs first.

Parts used to repair a Warrantable Failure may be new Cummins parts, Cummins-approved rebuilt parts, or repaired parts. Cummins is not responsible for failures resulting from the use of parts not approved by Cummins.

A new Cummins or Cummins-approved rebuilt part used to repair a Warrantable Failure assumes the identity of the part it replaced and is entitled to the remaining coverage hereunder.

**CUMMINS DOES NOT COVER WEAR OR WEAROUT OF COVERED PARTS.**

**CUMMINS IS NOT RESPONSIBLE FOR INCIDENTAL OR CONSEQUENTIAL DAMAGES.**

**THESE WARRANTIES SET FORTH HEREIN ARE THE SOLE WARRANTIES MADE BY CUMMINS IN REGARD TO THESE ENGINES. CUMMINS MAKES NO OTHER WARRANTIES, EXPRESS OR IMPLIED, OR OF MERCHANTABILITY OR FITNESS FOR A PARTICULAR PURPOSE.**

This warranty gives you specific legal rights, and you may also have other rights which vary from state to state.

### **Emission Warranty**

#### **Products Warranted**

This emission warranty applies to new Engines marketed by Cummins that are used in the United States\* in vehicles designed for Industrial off-highway use. This warranty applies to Engines delivered to the ultimate purchaser on or after April 1, 1999 for engines up to 750 horsepower, on or after January 1, 2000 for engines 751 horsepower and over.

#### **Coverage**

Cummins warrants to the ultimate purchaser and each subsequent purchaser that the Engine is designed, built and equipped so as to conform at the time of sale by Cummins with all U.S. Federal emission regulations applicable at the time of manufacture and that it is free from defects in workmanship or material which would cause it not to meet these regulations within the longer of the following periods: (A) Five years or 3,000 hours of operation, whichever

occurs first, as measured from the date of delivery of the Engine to the ultimate purchaser, or (B) The Base Engine Warranty.

If the vehicle in which the Engine is installed is registered in the state of California, a separate California Emission Warranty also applies.

Limitations

Failures, other than those resulting from defects in materials, or workmanship, are not covered by this warranty.

Cummins is not responsible for failures or damage resulting from what Cummins determines to be abuse or neglect, including, but not limited to: operation without adequate coolant or lubricants; overfueling; overspeeding; lack of maintenance of lubricating, cooling or intake systems; improper storage, starting, warm-up, run-in or shutdown practices; unauthorized modifications of the Engine. Cummins is also not responsible for failures caused by incorrect fuel or by water, dirt or other contaminants in the fuel.

Cummins is not responsible for non-Engine repairs, "downtime" expenses, cargo damage, fines, all business costs or other losses resulting from a Warrantable Failure.

CUMMINS IS NOT RESPONSIBLE FOR INCIDENTAL OR CONSEQUENTIAL DAMAGES.

\* Includes American Samoa, the Commonwealth of Northern Mariana Islands, Guam, Puerto Rico, and the U.S. Virgin Islands.

\*\* Alternators, starters, and fans ARE covered for the duration of the base engine warranty on A series and B3.3 engines.

## All Engines International Industrial (Off-Highway)

### Coverage

#### PRODUCTS WARRANTED

This warranty applies to new Engines sold by Cummins and delivered to the first user on or after April 1, 1999, that are used in industrial (off-highway) applications anywhere in the world where Cummins-approved service is available, except the United States\* and Canada. Different warranty coverage is provided for Engines used in marine, generator drive and certain defense applications.

#### BASE ENGINE WARRANTY

This warranty covers any failures of the Engine, under normal use and service, which result from a defect in material or factory workmanship (Warrantable Failure).

Coverage begins with the sale of the Engine by Cummins. Coverage continues for two years or 2,000 hours of operation, whichever occurs first, from the date of delivery of the Engine to the first user, or from the date the unit is first leased, rented or loaned, or when the Engine has been operated for 50 hours, whichever occurs first. If the 2,000 hour limit is exceeded during the first year, coverage continues until the end of the first year.

#### EXTENDED MAJOR COMPONENTS WARRANTY

The Extended Major Components Warranty covers Warrantable Failures of the Engine cylinder block, camshaft, crankshaft and connecting rods (Covered Parts).

Bushing and bearing failures are not covered.

This coverage begins with the expiration of the Base Engine Warranty and ends three years or 10,000\* hours of operation, from the date of delivery of the Engine to the first user, or from the date the unit is first leased, rented or loaned, or when the Engine has been operated for 50 hours, whichever occurs first.

\*3,000 hours for A series engines.

These warranties are made to all Owners in the chain of distribution, and Coverage continues to all subsequent Owners until the end of the periods of Coverage.

### Cummins' Responsibilities

#### DURING THE BASE ENGINE WARRANTY

Cummins will pay for all parts and labor needed to repair the damage to the Engine resulting from a Warrantable Failure.

Cummins will pay for the lubricating oil, antifreeze, filter elements, and other maintenance items that are not reusable due to a Warrantable Failure.

Cummins will pay reasonable costs for mechanics to travel to and from the equipment site, including meals, mileage and lodging, when the repair is performed at the site of the failure.

Cummins will pay reasonable labor costs for Engine removal and reinstallation when necessary to repair a Warrantable Failure.

#### DURING THE EXTENDED MAJOR COMPONENTS WARRANTY

Cummins will pay for the repair or, at its option, replacement of the defective Covered Part and any Covered Part damaged by a Warrantable Failure of the defective Covered part.

### Owner's Responsibilities

#### DURING THE BASE ENGINE WARRANTY

Owner is responsible for the cost of lubricating oil, antifreeze, filter elements and other maintenance items replaced during warranty repairs unless such items are not reusable due to the Warrantable Failure.

#### DURING THE EXTENDED MAJOR COMPONENTS WARRANTY

Owner is responsible for the cost of all labor needed to repair the Engine, including the labor to remove and reinstall the Engine. When Cummins elects to repair a part instead of replacing it, Owner is not responsible for the labor needed to repair the part.

Owner is responsible for the cost of all parts required for the repair except for the defective Covered Part and any Covered Part damaged by a Warrantable Failure of the defective Covered Part.

Owner is responsible for the cost of lubricating oil, antifreeze, filter elements and other maintenance items replaced during repair of a Warrantable Failure.

DURING THE BASE ENGINE AND EXTENDED MAJOR COMPONENTS WARRANTIES

Owner is responsible for the operation and maintenance of the Engine as specified in the applicable Cummins Operation and Maintenance Manual. Owner is also responsible for providing proof that all recommended maintenance has been performed.

Before the expiration of the applicable warranty, Owner must notify a Cummins distributor, authorized dealer or other repair location approved by Cummins of any Warrantable Failure and make the product available for repair by such facility. Locations are listed in the Cummins International Sales and Service Directory.

Owner is responsible for communication expenses, meals, lodging and similar costs incurred as a result of a Warrantable Failure.

Owner is responsible for non-Engine repairs, "downtime" expenses, cargo damage, fines, all applicable taxes, all business costs and other losses resulting from a Warrantable Failure.

Limitations

Cummins is not responsible for failures or damage resulting from what Cummins determines to be abuse or neglect, including, but not limited to: operation without adequate coolants or lubricants; overfueling; overspeeding; lack of maintenance of lubricating, cooling or intake systems; improper storage, starting, warm-up, run-in or shutdown practices; unauthorized modifications of the Engine. Cummins is also not responsible for failures caused by incorrect oil or fuel or by water, dirt or other contaminants in the fuel or oil.

For power units and fire pumps (package units) the warranty applies to accessories, except for clutches and filters supplied by Cummins which bear the name of another company.

Non-Cummins starters, alternators, power steering pumps and air compressors supplied by Cummins that are not supplied as part of a package unit are covered for six months from the date of delivery of the Engine to the first user, or from the date the unit is first leased, rented or loaned, or when the Engine has been operated for 50 hours, whichever occurs first. Cummins branded parts noted above supplied by Cummins are covered for the entire Base Warranty period.

Except for the accessories noted previously, Cummins does not warrant accessories which bear the name of another company. Such non-warranted accessories include, but are not limited to: alternators, starters, fans\*, air conditioning compressors, clutches, filters, transmissions, torque converters, steering pumps, non-Cummins fan drives, and air cleaners.

Cummins Compusave units are covered by a separate warranty.

Before a claim for excessive oil consumption will be considered, Owner must submit adequate documentation to show that consumption exceeds Cummins published standards.

Failures of belts and hoses supplied by Cummins are not covered beyond the first 500 hours or one year of operation, whichever occurs first.

Parts used to repair a Warrantable Failure may be new Cummins parts, Cummins-approved rebuilt parts, or repaired parts. Cummins is not responsible for failures resulting from the use of parts not approved by Cummins.

A new Cummins or Cummins-approved rebuilt part used to repair a Warrantable Failure assumes the identity of the part it replaced and is entitled to the remaining coverage hereunder.

CUMMINS DOES NOT COVER WEAR OR WEAROUT OF COVERED PARTS.

CUMMINS IS NOT RESPONSIBLE FOR INCIDENTAL OR CONSEQUENTIAL DAMAGES.

THESE WARRANTIES SET FORTH HEREIN ARE THE SOLE WARRANTIES MADE BY CUMMINS IN REGARD TO THESE ENGINES. CUMMINS MAKES NO OTHER WARRANTIES, EXPRESS OR IMPLIED, OR OF MERCHANTABILITY OR FITNESS FOR A PARTICULAR PURPOSE.

In case of consumer sales, in some countries, the Owner has statutory rights which cannot be affected or limited by the terms of this warranty.

Nothing in this warranty excludes or restricts any contractual rights the Owner may have against third parties.

\* Alternators, starters, and fans ARE covered for the duration of the base engine warranty on A series and B3.3 engines.

## California Emission Control System Warranty, Off-Highway

### Products Warranted

This Emission Control System Warranty applies to off-road diesel engines certified with the California Air Resources Board beginning with the year 1996 for engines up to 750 horsepower, beginning with the year 2000 for 751 horsepower and over, marketed by Cummins, and registered in California for use in industrial off-highway applications.

### Your Warranty Rights and Obligations

The California Air Resources Board and Cummins Engine Company, Inc., are pleased to explain the emission control system warranty on your engine. In California, new off-road diesel engines must be designed, built and equipped to meet the State's stringent anti-smog standards. Cummins must warrant the emission control system on your engine for the periods of time listed below provided there has been no abuse, neglect or improper maintenance of your engine.

Your emission control system may include parts such as the fuel injection system and the air induction system. Also included may be hoses, belts, connectors and other emission-related assemblies.

Where a warrantable condition exists, Cummins will repair your off-road diesel engine at no cost to you including diagnosis, parts and labor.

### Manufacturer's Warranty Coverage

This warranty coverage is provided for 5 years or 3,000 hours of engine operation, whichever first occurs from the date of delivery of the engine to the first user. If any emission-related part on your engine is defective, the part will be repaired or replaced by Cummins.

Coverage

This emission control system warranty applies only to the following A series, B3.3, B3.9, B4.5s, B5.9, B6.7s, QSB3.9-30, QSB4.5-30, QSB5.9-30, QSB5.9-44, C8.3, QSC8.3, and QSL9 emission control parts:

Fuel Pump

- Static Timing
Delivery Valve
Injection Control Valve Module

Intake Manifold

- Charge Air Cooler
Aftercooler

Injectors

- Calibration
Needle
Nozzle
Spring

Exhaust Manifold

Oxidation Catalyst

Electronic Control System

- Control Module
Boost Pressure Sensor
Coolant Temperature Sensor
Fuel Pressure Sensor

Turbocharger

- Compressor Wheel
Turbine Wheel
Turbine Oil Seal
Wastegate Valve

## Owner's Warranty Responsibilities

As the off-road diesel engine owner, you are responsible for the performance of the required maintenance listed in your Cummins Operation and Maintenance Manual. Cummins recommends that you retain all receipts covering maintenance on your off-road diesel engine, but Cummins cannot deny warranty solely for the lack of receipts or for your failure to ensure the performance of all scheduled maintenance.

You are responsible for presenting your off-road diesel engine to a Cummins dealer as soon as a problem exists. The warranty repairs should be completed in a reasonable amount of time, not to exceed 30 days.

As the off-road diesel engine owner, you should also be aware that Cummins may deny you warranty coverage if your off-road diesel engine or a part has failed due to abuse, neglect, improper maintenance or unapproved modifications.

Your engine is designed to operate on diesel fuel only. Use of any other fuel may result in your engine no longer operating in compliance with California's emissions requirements.

If you have any questions regarding your warranty rights and responsibilities, you should contact Cummins Customer Assistance Department at 1-800-343-7357 (1-800-DIESELS) or the California Air Resources Board at 9528 Telstar Avenue, El Monte, CA 91731.

Prior to the expiration of the applicable warranty, Owner must give notice of any warranted emission control failure to a Cummins distributor, authorized dealer or other repair location approved by Cummins and deliver the engine to such facility for repair. Repair locations are listed in Cummins United States and Canada Service Directory.

Owner is responsible for incidental costs such as: communication expenses, meals, lodging incurred by Owner or employees of Owner as a result of a warrantable failure.

Owner is responsible for business costs and losses, "downtime" expenses, and cargo damage resulting from a warrantable failure. CUMMINS IS NOT RESPONSIBLE FOR OTHER INCIDENTAL OR CONSEQUENTIAL DAMAGES, INCIDENTAL OR CONSEQUENTIAL DAMAGES INCLUDE BUT ARE NOT LIMITED TO FINES, THEFT, VANDALISM OR COLLISIONS.

## Replacement Parts

Cummins recommends that any service parts used for maintenance, repair or replacement of emission control systems be new, genuine Cummins or Cummins approved rebuilt parts and assemblies, and that the engine be serviced by a Cummins distributor, authorized dealer or the repair location approved by Cummins. The owner may elect to have maintenance, replacement or repair of the emission control parts performed by a facility other than a Cummins distributor, an authorized dealer or a repair location approved by Cummins, and may elect to use parts other than new genuine Cummins or Cummins approved rebuilt parts and assemblies for such maintenance, replacement or repair; however, the cost of such service or parts will not be covered under this emission control system warranty.

## Cummins Responsibilities

Repairs and service will be performed by any Cummins distributor, authorized dealer or other repair location approved by Cummins using new, genuine Cummins or Cummins approved rebuilt parts and assemblies. Cummins will repair any of the emission control parts found by Cummins to be defective without charge for parts or labor (including diagnosis which results in determination that there has been a failure of a warranted emission control part).

## Emergency Repairs

In the case of an emergency where a Cummins distributor, authorized dealer, or other repair location approved by Cummins is not available, repairs may be performed by any available repair location using any replacement parts. Cummins will reimburse the Owner for expenses (including diagnosis), not to exceed the manufacturer's suggested retail price for all warranted parts replaced and labor charges based on the manufacturer's recommended time allowance for the warranty repair and the geographically appropriate hourly labor rate. A part not being available within 30 days or a repair not being complete within 30 days constitutes an emergency. Replaced parts and paid invoices must be presented at a Cummins authorized repair facility as a condition of reimbursement for emergency repairs not performed by a Cummins distributor, authorized dealer, or other repair location approved by Cummins.

## Warranty Limitations

Cummins is not responsible for failures resulting from Owner or operator abuse or neglect, such as: operation without adequate coolant, fuel or lubricants; overfueling; overspeeding; lack of maintenance of lubricating, cooling or air intake systems; improper storage, starting, warm-up, run-in or shutdown practices.

The manufacturer warrants to the ultimate purchaser and each subsequent purchaser that the engine is designed, built, and equipped so as to conform with all applicable regulations adopted by the Air Resources Board, and that it is free from defects in materials and workmanship which cause the failure of a warranted part.

Any warranted part which is not scheduled for replacement as required maintenance, or which is scheduled only for regular inspection to the effect of "repair or replace as necessary" is warranted for the warranty period.



Any warranted part which is scheduled for replacement as required maintenance is warranted for the period of time prior to the first scheduled replacement point for that part.

The owner will not be charged for diagnostic labor which leads to the determination that a warranted part is defective, if the diagnostic work is performed at a warranty station.

The manufacturer is liable for damages to other engine components caused by the failure under warranty of any warranted part.

Cummins is not responsible for failures resulting from improper repair or the use of parts which are not genuine Cummins or Cummins approved parts.

These warranties, together with the express commercial warranties and emission warranty are the sole warranties of Cummins. There are no other warranties, express or implied, or of merchantability or fitness for a particular purpose.



<b>Acronyms and Abbreviations</b> .....	i-5
General Information.....	i-5
<b>Additional Service Literature</b> .....	L-1
General Information.....	L-1
<b>California Emission Control System Warranty, Off-Highway</b> .....	W-6
<b>Cold Weather Starting</b> .....	1-5
Ether Starting Aids.....	1-5
General Information.....	1-5
Grid Heater.....	1-5
With Mechanical or Electrical Metering Equipment (Ether).....	1-5
<b>Coolant Recommendations and Specifications</b> .....	V-6
Cooling System Sealing Additives.....	V-7
Cooling System Soluble Oils.....	V-7
Fully Formulated Coolant/Antifreeze.....	V-6
<b>Cummins Customized Parts Catalog</b> .....	L-3
General Information.....	L-3
Ordering the Customized Parts Catalog.....	L-3
Ordering by Telephone.....	L-3
Ordering On-Line.....	L-3
<b>Cummins/Fleetguard® Filter Specifications</b> .....	V-2
General Information.....	V-2
<b>Electromagnetic Interference (EMI)</b> .....	1-9
General Information.....	1-9
System EMI Radiation Levels.....	1-9
System EMI Susceptibility.....	1-9
<b>Engine Identification</b> .....	E-1
Cummins® Engine Nomenclature.....	E-2
Engine Dataplate.....	E-1
Fuel Injection Pump Dataplate.....	E-3
Bosch® Rotary.....	E-3
Delphi Rotary.....	E-3
<b>Engine Operating Range</b> .....	1-9
General Information.....	1-9
<b>Engine Shutdown</b> .....	1-9
General Information.....	1-9
<b>Fuel Recommendations and Specifications</b> .....	V-3
Fuel Recommendations.....	V-3
<b>General Safety Instructions</b> .....	i-3
Important Safety Notice.....	i-3
<b>General Engine</b> .....	V-1
Specifications.....	V-1
<b>Illustrations</b> .....	i-2
General Information.....	i-2
<b>Lubricating Oil Recommendations and Specifications</b> .....	V-4
Arctic Operation.....	V-5
General Information.....	V-4
New Engine Break-in Oils.....	V-5
<b>Maintenance Guidelines - Overview</b> .....	2-1
General Information.....	2-1
<b>Maintenance Record Form</b> .....	2-4
Maintenance Data.....	2-4
<b>Maintenance Schedule</b> .....	2-2
General Information.....	2-2
Oil Drain Intervals.....	2-2
<b>Normal Starting Procedure</b> .....	1-2
General Information.....	1-2
Jump Starting.....	1-4
<b>All Engines International/Industrial (Off-Highway)</b> .....	W-4
<b>All Engines United States and Canada/Industrial (Off-Highway)</b> .....	W-1
<b>Operating Instructions - Overview</b> .....	1-1
General Information.....	1-1
<b>Operating the Engine</b> .....	1-6
Ambient Temperature.....	1-7
0 to -32°C [32 to -25°F].....	1-7
-32 to -54°C [-25 to -65°F].....	1-7
Cold Weather.....	1-7
Normal.....	1-6
Winterfronts and Shutters.....	1-8
<b>Service Literature Ordering Location</b> .....	L-2
Contact Information.....	L-2
<b>Starting Procedure After Extended Shutdown or Oil Change</b> .....	1-6
General Information.....	1-6
<b>Symbols</b> .....	i-1
General Information.....	i-1

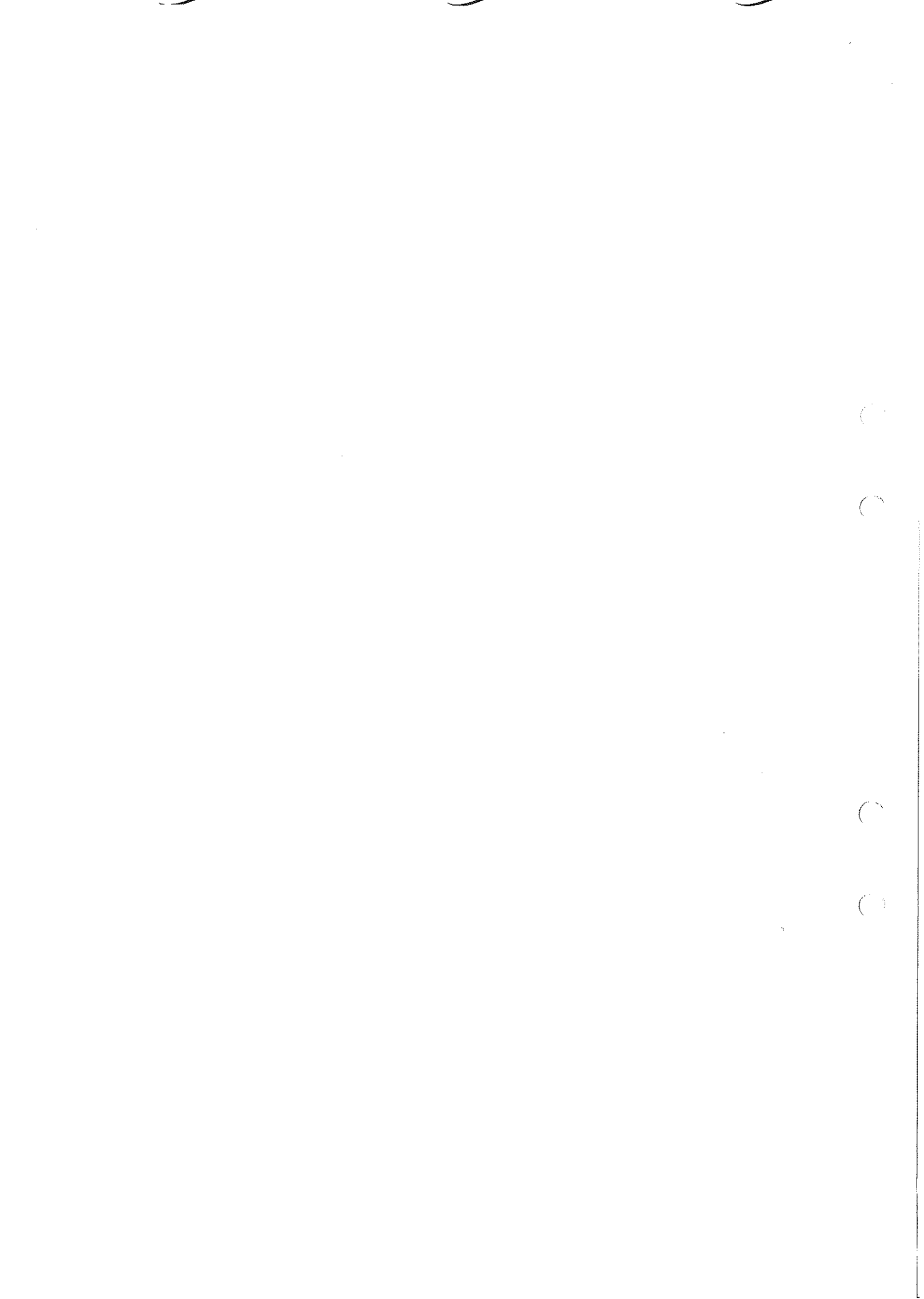

**Cummins Inc.**  
Box 3005  
Columbus, Indiana, U.S.A., 47202

Registered Office  
**Cummins Engine Company, Ltd**  
46-50 Coombe Road  
New Malden,  
Surrey KT3 4QL,  
England  
Registration 573951 England

Copyright© 2005  
Cummins Inc.

(

(

(

(