

# Instruction manual

## Operation & Maintenance

ICC424HF-CN1EN2.pdf

**Vibratory roller  
CC424HF**

**Engine  
Cummins QSB 4.5**

**Serial number  
\*384C30001\* - \*384C30010\*  
10000320x0C002131 -**



Translation of original instruction



## Table of Contents

Introduction .....	1
Warning symbols.....	1
Safety information .....	1
General .....	1
Safety - General instructions.....	3
Safety - when operating.....	5
Slopes .....	5
Driving near edges .....	6
Safety (Optional).....	7
Air conditioning.....	7
Edge cutter/compactor .....	7
Working lights - Xenon .....	8
Special instructions .....	9
Standard lubricants and other recommended oils and fluids .....	9
Higher ambient temperatures, above +40°C (104°F).....	9
Lower ambient temperature - Freeze risk .....	9
Temperatures.....	9
High pressure cleaning .....	10
Fire fighting .....	10
Roll Over Protective Structure (ROPS), ROPS approved cab .....	10
Battery handling .....	10
Jump starting (24V).....	11
Technical specifications .....	13
Vibrations - Operator station .....	13
Noise level.....	13
Electrical system .....	13
Dimensions, side view.....	14
Dimensions, top view .....	15
Weights and volumes.....	15
Working capacity .....	16

General .....	16
Hydraulic system .....	17
Automatic Climate Control (ACC) (Optional).....	17
Tightening torque .....	18
Machine description .....	19
Identification .....	19
Product identification number on the frame .....	19
Machine plate .....	19
Explanation of 17PIN serial number .....	20
Engine plates .....	20
Decals.....	21
Location - decals .....	21
Safety decals.....	22
Info decals .....	24
Instruments/Controls .....	25
Control panel and controls .....	25
Function descriptions .....	26
Display explanations .....	29
Machine alarm.....	32
"MAIN MENU" .....	33
"USER SETTINGS" .....	34
"MACHINE SETTINGS".....	35
"SERVICE MENU" .....	35
"ABOUT" .....	37
Operator help when starting.....	37
Operator help Workmode.....	37
Instruments and controls, cab .....	38
Function description of instruments and controls in the cab .....	39
Using the cab controls.....	40
Defroster .....	40

Heat .....	40
AC/ACC .....	40
Electrical system.....	41
Fuses .....	42
Fuses in cab.....	42
Operation .....	43
Before starting .....	43
Master switch - Switching on.....	43
Control panel, adjustments .....	43
Operator's seat - Adjustment.....	44
Operator's seat, comfort - Adjustments.....	44
Parking brake .....	45
Display - Control.....	45
Interlock.....	46
Operator position.....	47
View .....	47
Starting .....	48
Starting the engine .....	48
Display when activating choice via the button set.....	49
Alarm descriptions.....	50
Driving .....	50
Operating the roller .....	50
Machine with gear change in the speed potentiometer. ....	51
Machine with gear change in separate 3-position switch (gear position switch) .....	51
Interlock/Emergency stop/Parking brake - Check .....	52
Pivotal steering (Optional).....	53
Edge cutting (Optional) .....	53
Vibration .....	54
Manual/Automatic vibration.....	54

Manual vibration - Switching on .....	55
Amplitude/frequency - Changeover .....	55
Braking .....	55
Normal braking .....	55
Emergency braking .....	56
Switching off .....	56
Parking .....	57
Chocking the drums .....	57
Master switch .....	57
Long-term parking .....	59
Engine .....	59
Battery .....	59
Air cleaner, exhaust pipe .....	59
Watering system .....	59
Fuel tank .....	59
Hydraulic reservoir .....	59
Hoods, tarpaulin .....	60
Steering cylinder, hinges, etc. ....	60
Miscellaneous .....	61
Lifting .....	61
Locking the articulation .....	61
Lifting the roller .....	61
Lifting the roller with jack: .....	62
Unlocking the articulation .....	62
Towing/Recovering .....	62
Short distance towing with the engine running .....	63
Short distance towing when the engine is inoperative .....	63
Towing the roller .....	64
Trailer eye .....	64
Roller prepared for transport .....	65

Operating instructions - Summary .....	67
Preventive maintenance .....	69
Acceptance and delivery inspection .....	69
Warranty .....	69
Maintenance - Lubricants and symbols .....	71
Maintenance symbols .....	72
Maintenance - Maintenance schedule .....	73
Service and maintenance points .....	73
General .....	74
Every 10 hours of operation (Daily) .....	74
After the FIRST 50 hours of operation .....	74
Every 50 hours of operation (Weekly) .....	75
Every 250 hours of operation (Monthly) .....	75
Every 500 hours of operation (Every three months) .....	75
Every 1000 hours of operation (Every six months) .....	76
Every 2000 hours of operation (Yearly) .....	76
Maintenance, 10h .....	77
Diesel engine - Check oil level .....	77
Coolant level - Check .....	78
Fuel tank - Refueling .....	78
Hydraulic reservoir - Check fluid level .....	79
Water tank, Std - Filling .....	79
Sprinkler system/Drum Check .....	80
Cleaning the coarse filter .....	80
Sprinkler system/Drum Cleaning of sprinkler nozzle .....	81
Emergency watering (Accessory) - Extra pump in pump system .....	81
Scrapers, spring-action Check .....	82

---

Scrapers	
Setting - Adjustment.....	82
Maintenance - 50h .....	85
Fuel filter - Draining.....	85
Air cleaner	
Checking - Change the main air filter.....	85
Backup filter - Change.....	86
Air cleaner	
- Cleaning.....	87
Drum gear - Checking the oil level.....	87
Air conditioning (Optional)	
- Inspection.....	88
Air conditioning (Optional)	
- Cleaning.....	88
Maintenance - 250h .....	89
Hydraulic fluid cooler	
Checking - Cleaning.....	89
Air conditioning (Optional)	
- Inspection.....	90
Battery	
- Check condition .....	90
Edge cutter (Optional)	
- Lubrication .....	91
Maintenance - 500h .....	93
Diesel engine	
Oil change .....	93
Engine	
Replacing oil filter.....	94
The engine fuel filter - replacement/cleaning .....	94
Drum - oil level	
Inspection - filling .....	95
Pivot bearing (Optional) - Lubrication.....	95
Seat bearing - Lubrication.....	96
Rubber elements and attachment screws	
Check.....	96





Hydraulic reservoir cap - Check .....	97
Maintenance - 1000h .....	99
Air filter - Change .....	99
Backup filter - Change.....	99
Hydraulic filter Change.....	100
Drum - Oil change .....	101
Drum gear - Oil change.....	101
Drum gear - Checking the oil level .....	102
Cab Fresh air filter - Replacing .....	102
Maintenance - 2000h .....	103
Hydraulic reservoir Fluid change.....	103
Fuel tank - Cleaning .....	104
Watering system - Draining.....	104
Water tank - Cleaning .....	105
Steering joint - Check.....	105
Air conditioning (Optional) - Overhaul .....	106
Air conditioning (Optional) Drying filter - Inspection .....	106




## Introduction


### Warning symbols


 **WARNING !** Marks a danger or a hazardous procedure that can result in life threatening or serious injury if the warning is ignored.

 **CAUTION !** Marks a danger or hazardous procedure that can result in damage to the machine or property if the warning is ignored.

### Safety information

 **The safety manual supplied with the machine must be read by all roller operators. Always follow the safety instructions. Do not remove the manual from the machine.**

 **We recommend that the operator reads the safety instructions in this manual carefully. Always follow the safety instructions. Ensure that this manual is always easily accessible.**

 **Read the entire manual before starting the machine and before carrying out any maintenance.**

 **Replace immediately the instruction manuals if lost, damaged or unreadable.**

 **Ensure good ventilation (extraction of air by fan) where the engine is run indoors.**

### General

This manual contains instructions for machine operation and maintenance.

The machine must be correctly maintained for maximal performance.

The machine should be kept clean so that any leakages, loose bolts and loose connections are discovered at as early a point in time as possible.

Inspect the machine every day, before starting. Inspect the entire machine so that any leakages or other faults are detected.

Check the ground under the machine. Leakages are more easily detected on the ground than on the machine itself.



**THINK ENVIRONMENT !** Do not release oil, fuel and other environmentally hazardous substances into the environment. Always send used filters, drain oil and fuel remnants to environmentally correct disposal.

This manual contains instructions for periodic maintenance normally carried out by the operator.



Additional instructions for the engine can be found in the manufacturer's engine manual.

## **Safety - General instructions**

(Also read the safety manual)



1. **The operator must be familiar with the contents of the OPERATION section before starting the roller.**
2. **Ensure that all instructions in the MAINTENANCE section are followed.**
3. **Only trained and/or experienced operators are to operate the roller. Passengers are not permitted on the roller. Remain seated at all times when operating the roller.**
4. **Never use the roller if it is in need of adjustment or repair.**
5. **Only mount and dismount the roller when it is stationary. Use the intended grips and rails. Always use the three-point grip (both feet and one hand, or one foot and both hands) when mounting or dismounting the machine. Never jump down from the machine.**
6. **The ROPS (Roll Over Protective Structure) should always be used when the machine is operated on unsafe ground.**
7. **Drive slowly in sharp bends.**
8. **Avoid driving across slopes. Drive straight up or straight down the slope.**
9. **When driving close to edges, ditches or holes, make sure that at least 2/3 of the drum width is on previously compacted material (solid surface).**
10. **Make sure that there are no obstacles in the direction of travel, on the ground, in front of or behind the roller, or overhead.**
11. **Drive particularly carefully on uneven ground.**
12. **Use the safety equipment provided. The seat belt must be worn on machines fitted with ROPS/ROPS-cab.**
13. **Keep the roller clean. Clean any dirt or grease that accumulates on the operator platform immediately. Keep all signs and decals clean and legible.**
14. **Safety measures before refueling:**
  - **Stop the engine**
  - **Do not smoke.**
  - **No naked flames in the vicinity of the roller.**
  - **Earth the filling equipment nozzle to the tank opening to avoid sparks.**
15. **Before repairs or service:**
  - **Chock the drums/wheels and under the strike-off blade.**
  - **Lock the articulation if necessary**

16. **Hearing protection is recommended if the noise level exceeds 85 dB(A). The noise level can vary depending on the equipment on the machine and the surface the machine is being used on.**
17. **Do not make any changes or modifications to the roller that could affect safety. Changes are only to be made after written approval has been given by Dynapac.**
18. **Avoid using the roller before the hydraulic fluid has reached its normal working temperature. Braking distances can be longer than normal when the fluid is cold. See instructions in the STOP section.**
19. **For your own protection always wear:**
  - helmet
  - working boots with steel toecaps
  - ear protectors
  - reflecting clothing/high visibility jacket
  - working gloves

## Safety - when operating



**Prevent persons from entering or remaining in the danger area, i.e. a distance of at least 7 m (23 ft) in all directions from operating machines. The operator may allow a person to remain in the danger area, but should then observe caution and operate the machine only when the person is visible or has given clear indications of where he or she is.**

### Slopes

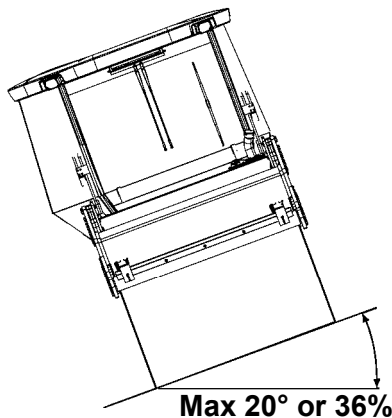
This angle has been measured on a hard, flat surface with the machine stationary.

The steering angle was zero, the vibration was switched OFF and all tanks were full.

Always take into consideration that loose ground, steering the machine, vibration on, machine speed across the ground and raising the center of gravity can all cause the machine to topple at smaller slope angles than those specified here.



**To exit the cab in an emergency, release the hammer on the rear right post and break the right opening side-windows.**



*Fig. Operating on slopes*



**It is recommended that ROPS (Roll Over Protective Structure) or a ROPS approved cab, is always used when driving on slopes or unsafe ground.**



**Where possible, avoid driving across slopes. Drive instead straight up and down sloping ground.**

**Driving near edges**

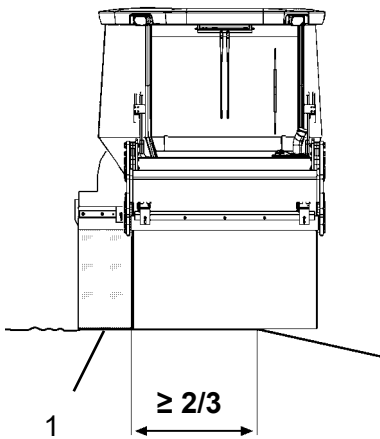
When driving near an edge, minimum 2/3 of the drum width must be on solid ground.



***When using pivotal steering, only one drum should be allowed to move into the position shown in the picture. The other drum must be in contact with the ground across its full width.***



***Keep in mind that the machine's center of gravity moves outwards when steering. For example, the center of gravity moves to the right when you steer to the left.***



**Fig. Position of drums when driving near an edge**  
**1. Pivotal steering**



## Safety (Optional)

### Air conditioning

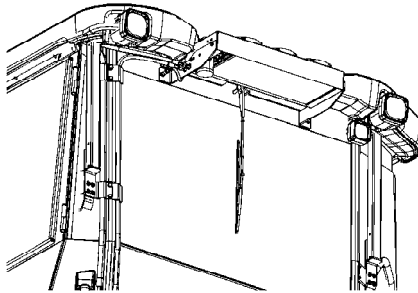


Fig. Air conditioning (ACC)



**The system contains pressurized refrigerant. It is forbidden to release refrigerants into the atmosphere.**



**Work on the refrigerant circuit is only to be carried out by authorized companies.**



**The cooling system is pressurized. Incorrect handling can result in serious personal injury. Do not disconnect or undo the hose couplings.**



**The system must be re-filled with an approved refrigerant by authorized personnel when necessary. See decal on or in the vicinity of the installation.**

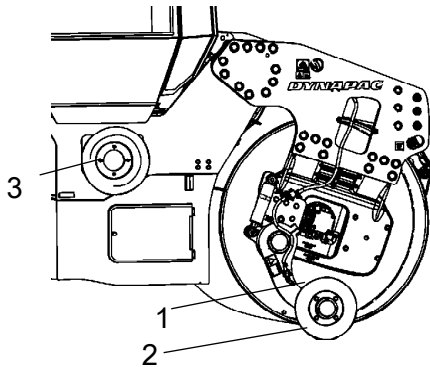


Fig. Edge cutter/compactor  
1. Transport position  
2. Operating position  
3. Holder for cutter/compactor wheel.

### Edge cutter/compactor



**The operator must make sure that nobody is in the area of operation while the machine is in use.**



**The edge cutter consists of rotating components and there is a risk of being crushed.**



**The tool must be returned to the transport position (raised position) (1) every time it has been used.**

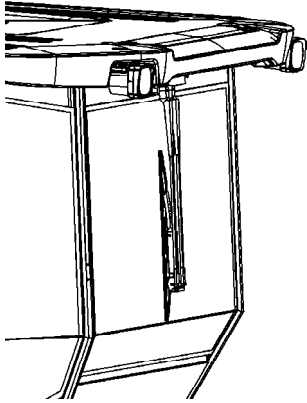


**If the edge cutter and its parts are dismantled, make sure that it is set in a relieved position and resting on the ground.**

### Working lights - Xenon



**Warning, high voltage!**



**Figure. Xenon lighting on cab**

The working lights of the Xenon type have a secondary high-voltage source.

Work on the lighting should only be conducted by an authorized electrician and with the primary voltage disconnected.

Contact a Dynapac dealer!



**Warning, environmentally hazardous waste!**

Working lights of the Xenon type include a discharge lamp that contains mercury (Hg).

A defective lamp is to be considered as hazardous waste and shall be disposed off as per local directives.

## **Special instructions**

### **Standard lubricants and other recommended oils and fluids**

Before leaving the factory, the systems and components are filled with the oils and fluids specified in the lubricant specification. These are suitable for ambient temperatures in the range -15°C to +40°C (5°F - 105°F).



The maximum temperature for biological hydraulic fluid is +35°C (95°F).

### **Higher ambient temperatures, above +40°C (104°F)**

For operation of the machine at higher ambient temperatures, however maximum +50°C (122°F), the following recommendations apply:

The diesel engine can be run at this temperature using normal oil. However, the following fluids must be used for other components:

Hydraulic system - mineral oil Shell Tellus T100 or similar.

### **Lower ambient temperature - Freeze risk**

Make sure that the watering system is empty/drained of water (sprinkler, hoses, tank/s) or that anti-freeze has been added, to prevent the system freezing.

The outlet hose from the central tank can be disconnected and the end placed in a container with antifreeze to run this through the pump/filter.

### **Temperatures**

The temperature limits apply to standard versions of rollers.

Rollers equipped with additional equipment, such as noise suppression, may need to be more carefully monitored in the higher temperature ranges.

### High pressure cleaning

Do not spray directly onto electrical components.



Do not use high pressure cleaning for dashboard/display.



The Electrical Drive Control and the computer box may not be washed with high pressure cleaning and not at all with water. Clean them with a dry wiper.



Detergent that can destroy electrical parts, or which is conductive, must not be used.

Place a plastic bag over the fuel filler cap and secure with a rubber band. This is to avoid high pressure water entering the vent hole in the filler cap. This could cause malfunctions, such as the blocking of filters.



Never aim the water jet directly at the fuel tank cap. This is particularly important when using a high-pressure cleaner.

### Fire fighting

If the machine catches fire, use an ABC-class powder fire extinguisher.

A BE-class carbon dioxide fire extinguisher can also be used.

### Roll Over Protective Structure (ROPS), ROPS approved cab



***If the machine is fitted with a Roll Over Protective Structure (ROPS, or ROPS approved cab) never carry out any welding or drilling in the structure or cab.***



***Never attempt to repair a damaged ROPS structure or cab. These must be replaced with new ROPS structure or cabs.***

### Battery handling



***When removing batteries, always disconnect the negative cable first.***



**When fitting batteries, always connect the positive cable first.**



Dispose of old batteries in an environmentally friendly way. Batteries contain toxic lead.



Do not use a quick-charger for charging the battery. This may shorten battery life.

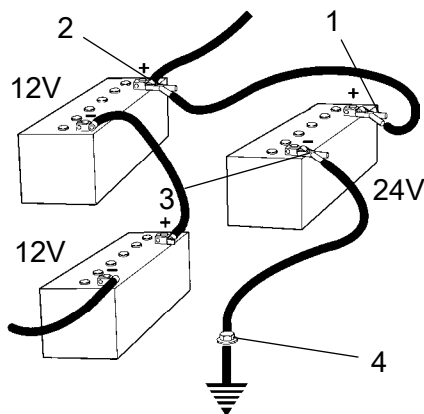
### Jump starting (24V)



**Do not connect the negative cable to the negative terminal on the dead battery. A spark can ignite the oxy-hydrogen gas formed around the battery.**



**Check that the battery used for jump starting has the same voltage as the dead battery.**



**Fig. Jump starting**

Turn the ignition and all power consuming equipment off. Switch off the engine on the machine which is providing jump start power.

### Jump leads must have 24V.

First connect the jump start battery's positive terminal (1) to the flat battery's positive terminal (2). Then connect the jump start battery's negative terminal (3) to, for example, a bolt (4) or the lifting eye on the machine with the flat battery.

Start the engine on the power providing machine. Let it run for a while. Now try to start the other machine. Disconnect the cables in the reverse order.



## Technical specifications

### Vibrations - Operator station (ISO 2631)

**The vibration levels are measured in accordance with the operational cycle described in EU directive 2000/14/EC on machines equipped for the EU market, with vibration switched on, on soft polymer material and with the operator's seat in the transport position.**

Measured whole-body vibrations are below the action value of 0.5 m/s<sup>2</sup> as specified in Directive 2002/44/EC. (Limit is 1.15 m/s<sup>2</sup>)

Measured hand/arm vibrations also were below the action level of 2.5 m/s<sup>2</sup> specified in the same directive. (Limit is 5 m/s<sup>2</sup>)

### Noise level

**The noise level is measured in accordance with the operational cycle described in EU directive 2000/14/EC on machines equipped for the EU market, on soft polymer material with vibration switched on and the operator's seat in the transport position.**

Guaranteed sound power level, L <sub>WA</sub>	82kW	107 dB (A)
	93kW	108 dB (A)
	113kW	109 dB (A)
Sound pressure level at the operator's ear (platform), L <sub>pA</sub>		91 ±3 dB (A)
Sound pressure level at the operator's ear (cab), L <sub>pA</sub>		85 ±3 dB (A)

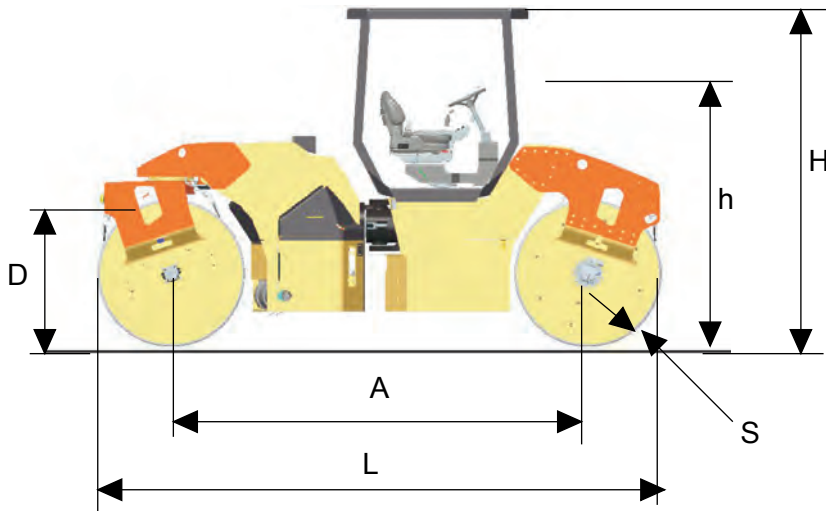
---

**During operation the above values may differ because of the actual operational conditions.**

### Electrical system

**Machines are EMC tested in accordance with EN 13309:2000 'Construction machinery'**

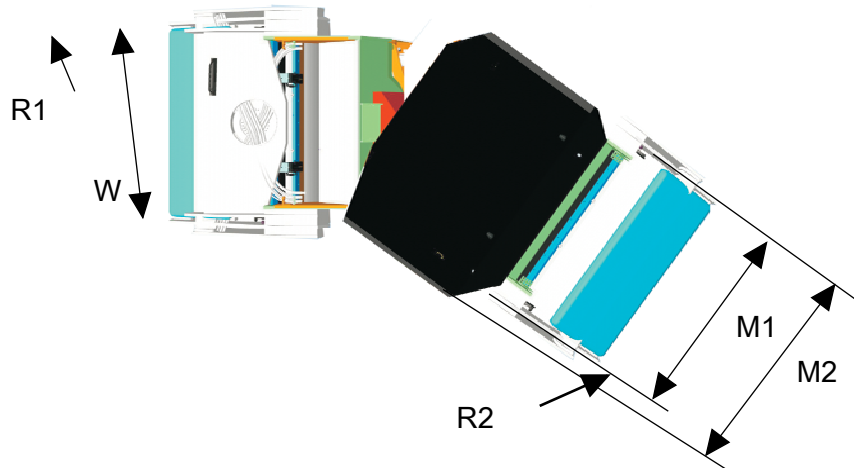
**Dimensions, side view**



Dimensions	mm	in
A	3690	145
D	1300	51
h	2275	90
H	2990	118
L	4990	196
S	18	0.71



**Dimensions, top view**



Dimensions	mm	in
M1	1890	74.5
M2	2345	92.3
R1: With offset drums	5960	235
R2: With offset drums	3225	127
R1: Without offset drums	7300	287
R2: Without offset drums	5570	219
W	1730	68

**Weights and volumes**

**Weights**

Service weight without ROPS	10 000 kg	22,050 lbs
Service weight with ROPS (EN500)	10 500 kg	23,150 lbs
Service weight with cab	10 500 kg	23,150 lbs

**Fluid volumes**

Fuel tank	230 liters	61 gal
Water tank/s		
- central	900 liters	238 gal

**Working capacity**

**Compaction data**

Static linear load, front	30,9 kg/cm	173 pli
Static linear load, rear	29,8 kg/cm	167 pli
Amplitude, high	0,8 mm	0.031 in
Amplitud, low	0,3 mm	0.012 in
Vibration frequency, high amplitude	51 Hz	3060 vpm
Vibration frequency, low amplitude	67 Hz	4020 vpm
Centrifugal force, high amplitude	142 kN	31 950 lbf
Centrifugal force, low amplitude	93 kN	20 925 lbf

**Propulsion**

Speed range	0-12 km/h	0-7.5 mph
Climbing capacity (theoretical)	45 %	

**General**

**Engine**

Manufacturer/Model	Cummins QSB 4.5	
Power (SAE J1995)	82/93 kW	110/125 hp
Engine speed	2200 rpm	

**Electrical system**

Battery	24V (2x12V 74Ah)	
Alternator	24V 45A	
Fuses	See the Electrical system section - fuses	

**Bulbs (if mounted)**

	<b>Watt</b>	<b>Socket</b>
Drive lights, front	75/70	P43t (H4)
Direction lights, front	21	BA15s
Side lights	5	SV8,5
Brake-Position lights	21/5	BAY15d

<b>Bulbs (if mounted)</b>	<b>Watt</b>	<b>Socket</b>
Direction lights, rear	21	BA15s
License plate light	5	SV8,5
Working lights	70	PK22s (H3)
	35	Xenon
Cab lights	10	SV8,5

### Hydraulic system

<b>Opening pressure</b>	<b>MPa</b>	<b>Psi</b>
Drive system	40	5 800
Supply system	2.5	365
Vibration system	33	4 800
Control systems	20	2 900
Brake release	1.8	260

### Automatic Climate Control (ACC) (Optional)

The system described in this manual is an AC/ACC type (Automatic Climate Control), i.e. a system that maintains the set temperature in the cab, provided windows and doors are kept closed.

Coolant designation: HFC-R134:A

Coolant weight when full: 1350 gram (2.98 lbs)

**Tightening torque**

Tightening torque in Nm (lbf.ft) for oiled or dry bolts tightened with a torque wrench.

**Metric coarse screw thread, bright galvanized (fzb):**

**STRENGTH CLASS:**

<b>M - thread</b>	<b>8.8, Oiled</b>	<b>8.8, Dry</b>	<b>10.9, Oiled</b>	<b>10.9, Dry</b>	<b>12.9, Oiled</b>	<b>12.9, Dry</b>
<b>M6</b>	8,4	9,4	12	13,4	14,6	16,3
<b>M8</b>	21	23	28	32	34	38
<b>M10</b>	40	45	56	62	68	76
<b>M12</b>	70	78	98	110	117	131
<b>M14</b>	110	123	156	174	187	208
<b>M16</b>	169	190	240	270	290	320
<b>M20</b>	330	370	470	520	560	620
<b>M22</b>	446	497	626	699	752	839
<b>M24</b>	570	640	800	900	960	1080
<b>M30</b>	1130	1260	1580	1770	1900	2100

**Metric coarse thread, zinc-treated (Dacromet/GEOMET):**

**STRENGTH CLASS:**

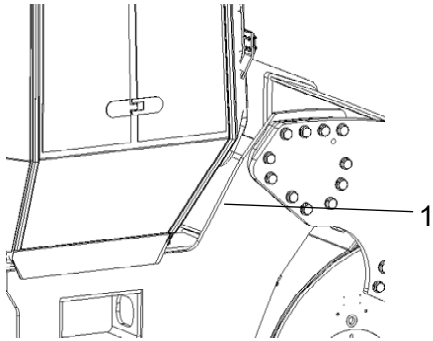
<b>M - thread</b>	<b>10.9, Oiled</b>	<b>10.9, Dry</b>	<b>12.9, Oiled</b>	<b>12.9, Dry</b>
<b>M6</b>	12,0	15,0	14,6	18,3
<b>M8</b>	28	36	34	43
<b>M10</b>	56	70	68	86
<b>M12</b>	98	124	117	147
<b>M14</b>	156	196	187	234
<b>M16</b>	240	304	290	360
<b>M20</b>	470	585	560	698
<b>M22</b>	626	786	752	944
<b>M24</b>	800	1010	960	1215
<b>M30</b>	1580	1990	1900	2360

**Machine description**

**Identification**

**Product identification number on the frame**

The machine PIN (Product Identification Number) (1) is punched on the right edge of the front frame.

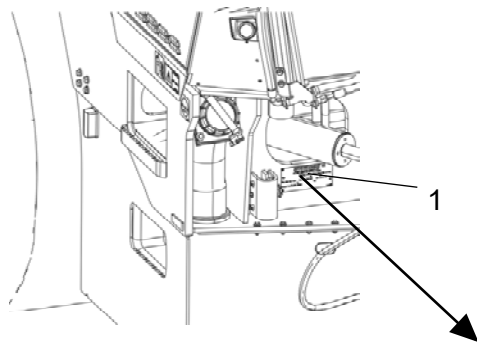


**Fig. PIN Front frame**

**Machine plate**

The machine type plate (1) is attached to the front left side of the frame, beside the steering joint.

The plate specifies among other things the manufacturer's name and address, the type of machine, the PIN, Product Identification Number (serial number), operating weight, engine power and year of manufacture. (In some cases there are no CE marking.)



**Fig. Operator platform  
1. Machine plate**

<b>DYNAPAC</b>			
Dynapac (China) Compaction & Paving Equipment Co.,Ltd. 38, Quanzhang Road, Wuzheng High Tech Ind. Park, Tianjin, China 301700			
Product Identification Number			
	Type	Rated Power	Max axle load front / rear
		kW	kg
Gross machinery mass	Operating mass	Max ballast	Year of Mfg.
kg	kg	kg	
			4811 0001 40

**Please state the machine's PIN when ordering spares.**

100	00123	V	0	A	123456
A	B	C	D	E	F

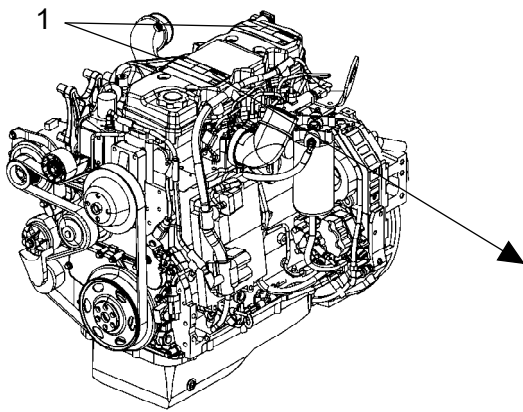
**Explanation of 17PIN serial number**

- A= Manufacturer
- B= Family/Model
- C= Check letter
- D= No coding
- E= Production unit
- F= Serial number

**Engine plates**

The engine plate (1) is affixed to the left side of the engine under the injection pump. Remove the metal cover at the top on the left of the engine compartment to access the plate.

The plate specifies the type of engine, its serial number and the engine specification. Please specify the engine serial number when ordering spares. Refer also to the engine manual.

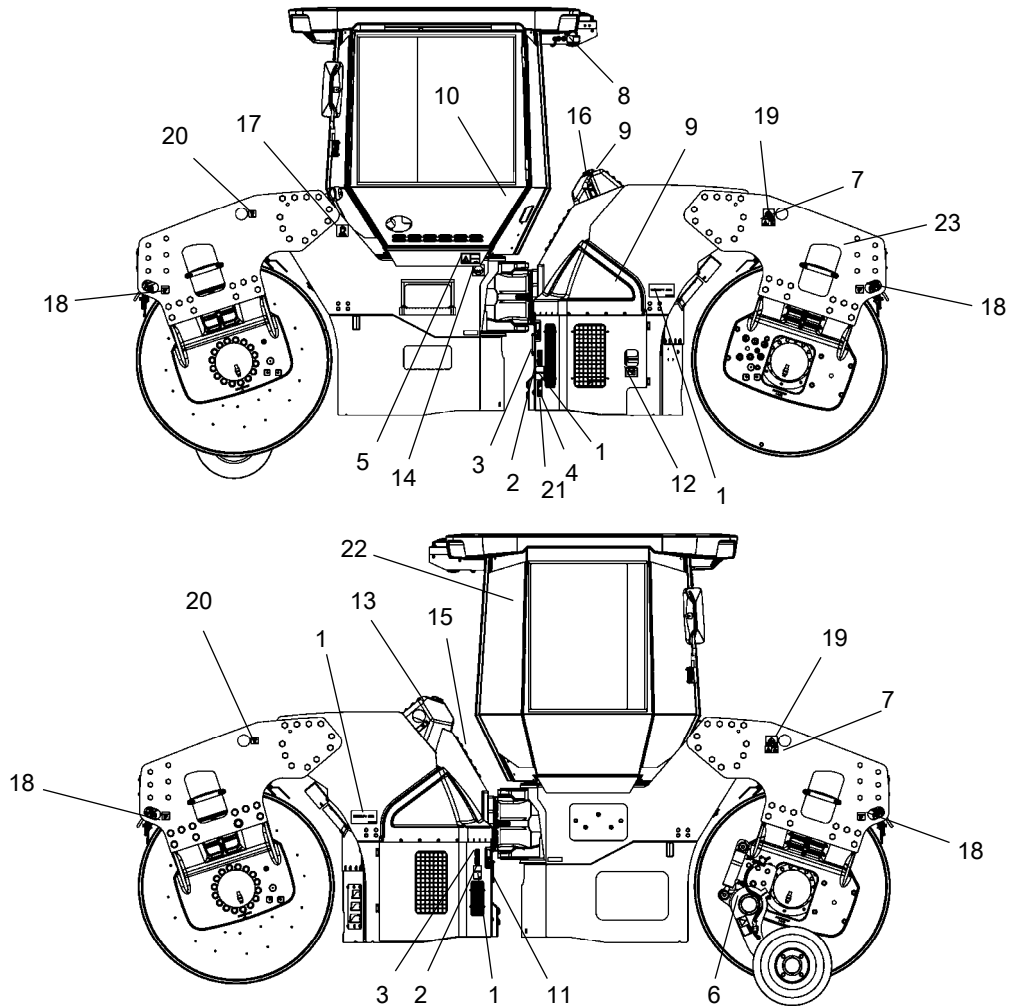


**Fig. Engine**  
**1. Type plate**

Cummins INC. Made in Great Britain www.cummins.com	Engine No. XXXXXXXX Family 7CEXL0275AAG Date of MFG DD-MM-YY												
	Ad. HP/kW 150/113 @ 2200 rpm e11e97/681A+2004/26+03383+XX Valve lash Inch 010 Int .020 Ex Cold mm 254 Int .508 Ex Ref. No. 379624		Model OSB4.5 CPL 8755 FR 91486 C.I.D./L 275/4.5	Fuel Rate at adv. HP 123 mm3/s1 Timing - TDC ELECTRONIC Firing Order 1-3-4-2 Idle Speed 850 rpm									
IMPORTANT ENGINE INFORMATION: This Engine Conforms To 2004 US EPA Regulations For Large Nonroad and Stationary Compression-Ignition Engines and California Regulations For Heavy-Duty Off-Road Diesel Cycle Engines As Applicable. WARNING: Injury May Result And Warranty Is Voided If Fuel Rate RPM Or Altitudes Exceed Published Maximum Values For This Model And Application. This Engine Is Certified To Operate On Diesel Fuel.			<table border="1"> <tr> <td>FEL</td> <td>EPA</td> </tr> <tr> <td>NOx</td> <td>4.0</td> </tr> <tr> <td>+NMHC</td> <td></td> </tr> <tr> <td>PM</td> <td>0.30</td> </tr> <tr> <td></td> <td>4935689</td> </tr> </table>	FEL	EPA	NOx	4.0	+NMHC		PM	0.30		4935689
FEL	EPA												
NOx	4.0												
+NMHC													
PM	0.30												
	4935689												

**Decals**

**Location - decals**

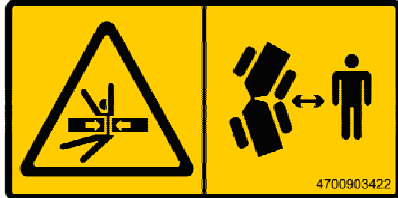


**Fig. Location, decals and signs**

1. Warning, Crush zone	4700903422	12. Master switch	4700904835
2. Warning, Rotating engine components	4700903423	13. Coolant	4700388449
3. Warning, Hot surfaces	4700903424	14. Water	4700991657
4. Warning, Brake release	4700904895	15. Hydraulic fluid level	4700272373
5. Warning, Instruction manual	4700903459	16. Hydraulic fluid Biological hydraulic fluid	4700272372 4700904601 / 4700792772
6. Warning, Edge cutter	4700904083	17. Diesel fuel	4700991658
7. Warning, Locking	4700908229	18. Fixing point	4700382751
8. Warning, Toxic gas	4700904165	19. Hoisting plate	4700904870
9. Warning, Starting gas	4700791642	20. Lifting point	4700357587
10. Handbook compartment	4700903425	21. Sound effect level	4700791277 / 78 / 79
11. Battery voltage	4700393959	22. Emergency exit	4700903590
		23. Air pressure (combi)	4700355983

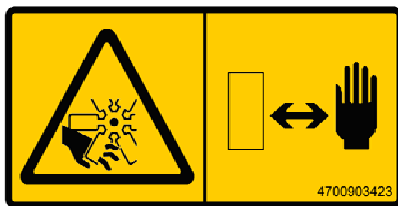
### Safety decals

Always make sure that all safety decals are completely legible, and remove dirt or order new decals if they have become illegible. Use the part number specified on each decal.



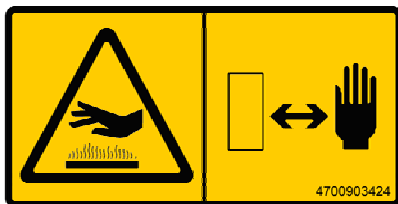
**4700903422**  
**Warning - Crush zone, articulation/drum.**

**Maintain a safe distance from the crush zone.**  
*(Two crush zones on machines fitted with pivotal steering)*



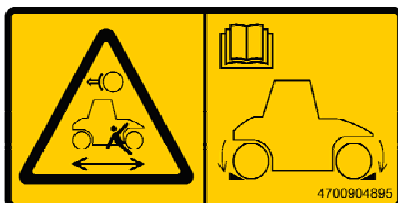
**4700903423**  
**Warning - Rotating engine components.**

**Keep your hands at a safe distance from the danger zone.**



**4700903424**  
**Warning - Hot surfaces in the engine compartment.**

**Keep your hands at a safe distance from the danger zone.**



**4700904895**  
**Warning - Brake disengagement**

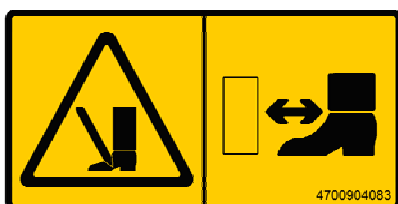
**Study the towing chapter before disengaging the brakes.**

**Danger of being crushed.**



**4700903459**  
**Warning - Instruction manual**

**The operator must read the safety, operation and maintenance instructions before operating the machine.**



**4700904083**  
**Warning - Edge cutter (option)**

**Warning of rotating parts.**

**Maintain a safe distance from the crush zone.**





**4700908229**

**Warning - Risk of crushing**

The articulation must be locked when lifting.

Read the instruction manual.



**4700904165**

**Warning - Toxic gas (option, ACC)**

Read the instruction manual.



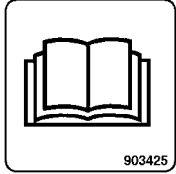
**4700791642**

**Warning - Starting gas**

Starting gas is not to be used.

Info decals

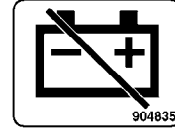
**Handbook compartment**



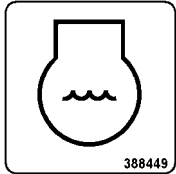
**Battery voltage**



**Master switch**



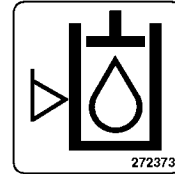
**Coolant**



**Water**



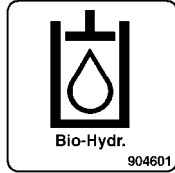
**Hydraulic fluid level**



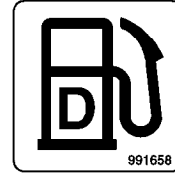
**Hydraulic fluid**



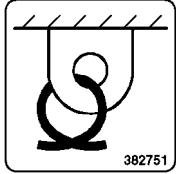
**Biological hydraulic fluid**



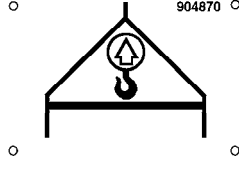
**Diesel fuel**



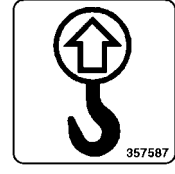
**Fixing point**



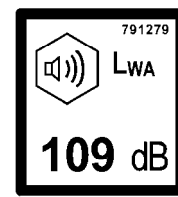
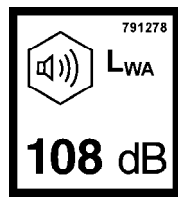
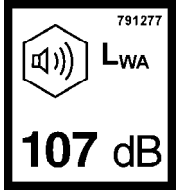
**Hoisting plate**



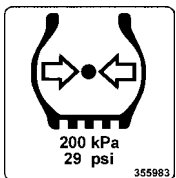
**Lift point**



**Sound effect level**



**Tire pressure(combi)**



**Biological hydraulic fluid  
PANOLIN**

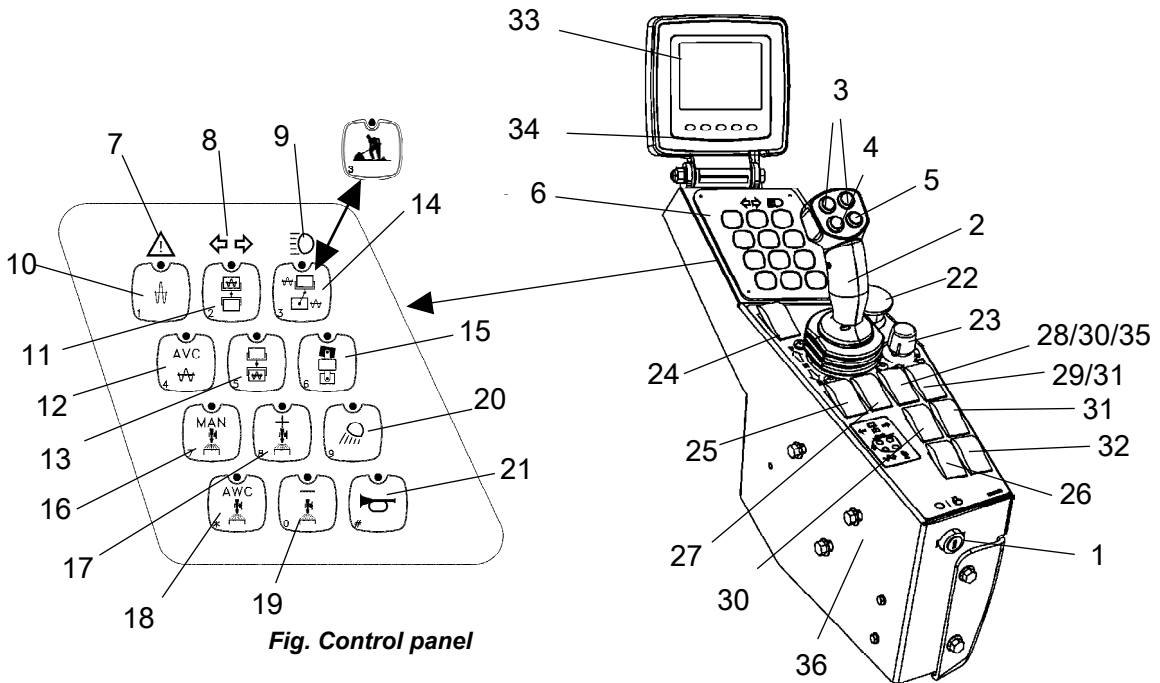


**Emergency exit**



**Instruments/Controls**

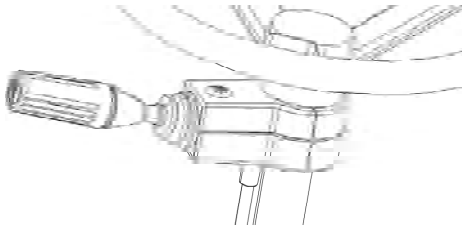
**Control panel and controls**



**Fig. Control panel**

1	Ignition switch	13	Vibration rear drum	25	Parking brake
2	Forward & Reverse lever	14	Work mode (Off-set and vibration permitted plus soft starting and stopping enabled)	26	* Hazard lights
3	* Offset left/right	15	CG – front drum steering only	27	* Rotating beacon
4	Vibration on/off	16	Manual sprinkler	28	* Gravel spreader (not for combi)
5	Panic sprinkler (ON as long as button depressed)	17	Increase sprinkler (timer)	29	Gear position switch
6	Button set	18	Auto sprinkler (AWC)	30	* Edge cutter, Up/Down
7	Central warning indicator	19	Decrease sprinkler (timer)	31	* Edge cutter, sprinkling
8	* Direction indicators	20	* Working light	32	* Drum edge lights
9	* Full beam indicator	21	Horn	33	Display
10	High amplitud	22	Emergency stop	34	Function buttons (5 pcs.)
11	Vibration front drum	23	Speed limiter	35	Sprinkling, emulsion tank (combi)
12	Auto vibration control (AVC)	24	Rpm switch, diesel engine	36	Height adjustment, control panel

\* Optional
















**Functions**





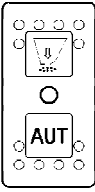


1. Direction indicators
2. Driving lights
3. Full/Dipped beam
4. Parking lights
5. Horn


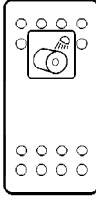
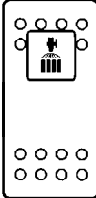
**Figure. Steering column switch (optional)**

**Function descriptions**

No	Designation	Symbol	Function
1	Ignition key		<p>The electric circuit is broken.</p> <p>All instruments and electric controls are supplied with power.</p> <p>Starter motor activation.</p> <p><b>To start: Turn ignition key to the right until the display LIGHTS UP, and wait until the displayed roller GOES OFF and changes to the status image.</b></p>
2	Forward/Reverse lever		<p><b>NB!</b> When starting the machine, the lever must be in neutral. The engine cannot be started if the forward/reverse lever is in any other position. The forward/reverse lever controls both the roller's driving direction and speed. When the lever is moved forward, the roller moves forward; when the lever is move backward, the roller moves backward. The roller's speed is proportional to the distance the lever is from the neutral position. The further the lever is from the neutral position, the higher the speed.</p>
3	Offset left/right		<p>The left button moves the rear drum to the left, the right button to the right. Reset by using the buttons until the symbol for Work mode shines continuously. (flashes in off-set)</p>
4	Vibration on/off		<p>First push will start vibrations, second push will stop vibrations.</p>
5	Panic sprinkling		<p>Panic sprinkling of both drums. Push the button to get full flow on sprinkler pump.</p>
6	Button set		
7	Central warning indication		<p>General fault indication. See display (33) for fault description.</p>
8	Direction indicators		<p>Shows direction indicators activated (Activated via the steering column switch).</p>
9	Main beam indicator		<p>Shows main beam activated (Activated via the steering column switch).</p>

No	Designation	Symbol	Function
10	Amplitude selector, high amplitude		Activation gives high amplitude. (Low amplitude is the basic mode if no button is activated.)
11	Vibration, front drum <b>NEVER</b> activate the switch when the switch (4) is activated.		Activation of vibration on front drum. If not Work mode (14) is activated, there will be no vibrations on the drums.
12	Automatic vibration control (AVC)		By activating the vibrations will be switched ON and OFF automatically when the F/R lever is moved from neutral and the roller reaches a preset speed.
13	Vibration rear drum <b>NEVER</b> activate the switch when the switch (4) is activated.		Activation of vibration on rear drum. If not Work mode (14) is activated, there will be no vibrations on the drums.
14	Work mode (Off-set and vibration permitted plus soft starting and stopping enabled)	 	Activation makes it possible to use vibration and offset (optional), and soft start and stop is activated. The roller is always starting in transportation mode.
(15)	Front drum steering only (CG)		Valid for pivot machines only (CG). By activating steering on front drum only.
16	Manual sprinkler		Continuous sprinkling on both drums.
17	Increasing sprinkling (timer)		Each push on the button gives higher sprinkling water volume on drums.
18	Automatic sprinkling		By activating the sprinkling water will engage and disengage automatically when the F/R lever is moved from neutral.
19	Decreasing sprinkling (timer)		Each push on the button gives lower sprinkling water volume on drums.
20	Working lights		By activating the working lights will turn ON.
21	Horn		Press to sound the horn.
22	Emergency stop		Brake the roller and switch off the engine. The power supply goes off. <b>When starting the machine the emergency stop must be inactive, but the parking brake must be applied.</b>

No	Designation	Symbol	Function
23	Speed limiter		Limitation of the machine's max. speed (max. speed is obtained with full deflection of the F/R lever). Set the knob to the required position and read the speed on the display (30).
24	Rpm switch, diesel engine		Three-position switch for idling, intermediate speed and working speed. <b>The control must be in the idling position to start the machine.</b> The diesel engine drops to even lower revs during idling, more than approx. 10 seconds if the F&R lever is in neutral. If the F&R lever is moved out of neutral the speed will increase to the set speed again.
25	Parking brake		When pressed the parking brake is activated. To release the brakes, slide the red part backwards (towards you) and change the position of the lever. <b>The parking brake must be activated to start the machine!</b>
26	Hazard warning lights		Activate the hazard warning light by depressing the button.
27	Rotating beacon		Activate the rotating beacon by depressing the button.
28	Gravel spreader		Activating the gravel spreader. Manual/Automatic spreading. (CC224-324)
29	Gear position switch		Position 1: Used for maximum gradeability when compacting with vibration Position 2: Normal position Position 3: Used for maximum transport speed or static compaction at high speed without vibration.
30	Edge press/cutter, UP/DOWN		The edge cutter can be moved up and down when the machine is in the operating position. The edge cutter can only be moved up when the machine is in transport position. Pressing on the lower edge moves the edge cutter down. Pressing on the upper edge moves the edge cutter up.

No	Designation	Symbol	Function
31	Edge press/cutter, sprinkling		Activate edge press/cutter sprinkling by depressing the switch.
32	Drum edge lights		Activate the drum edge lights by depressing the switch.
35	Sprinkler combi wheel		Activate the emulsion sprinkler for combi wheels by depressing the switch.

**Display explanations**



*Fig. Start screen*

When the ignition key is activated to position I, a start screen is visible in display. This is shown for a few seconds and then switches over to the status screen.



*Fig. Status screen*

A status screen provides information on the fuel level, water level in the sprinkler tank, machine hours and voltage level. Fuel and water levels are specified in per cent (%).

This screen is active until the Diesel engine is started or an active screen choice is made via the function buttons below the display.



**Fig. Main screen/Working screen**

If the engine is started before any active screen choice is made the display will switch over to main screen.

This screen gives an overview and is kept during work:

- The speed is shown in the middle of the screen.
- The engine speed, vibration frequencies for forward and reverse (Option), strokes/meter - Impactometer (Option), and asphalt temperature (Option), are shown in the corner.



1

**Fig. Main screen/Working screen with menu selection buttons (1)**

A menu field is shown by pressing one of the menu select buttons. The field is visible for a short while, if no selection is made the field fades out. Menu field will appear again upon pressing either one of the selection buttons (1).

Example of menu field.



	Scroll/Selection buttons to choose between available functions.
	Alarm log button to display engine and machine alarms.
	Settings/Button select menu, which opens the main menu. Settings can be changed in the main menu.
	Exit/Return button returns 1 step at once. Pressing the button (approx. 2 sec.) displays the main menu again.





**Fig. Temperature screen**

The temperature screen shows the temperature of the engine (top of display) and hydraulic fluid (bottom of display). The values are shown in Celsius or Fahrenheit, depending on the choice of unit system.

A menu for the asphalt temperature and Impactometer value can also be shown when an accessory asphalt temperature gauge and/or Impactometer is installed on the machine. Further information on these accessories are given in the Accessory Manuals.



**Fig. Asphalt temperature/Impactometer screen**



When an engine alarm is activated, the alarm is shown on the display.

The engine alarm is sent out from the engine ECM, which handles the monitoring of the engine functions.

The message, which consists of an SPN and FMI code, can be interpreted via the engine supplier error code list.










The alarm message shown is acknowledged by pressing the "OK" button on the display.



When a machine alarm is activated the alarm is shown on the display, plus a warning text that describes the alarm.


The alarm message shown is acknowledged by pressing the "OK" button on the display.

**Machine alarm**

Symbol	Designation	Function
	Warning symbol, hydraulic fluid filter	If the symbol is shown when the diesel engine is running at full speed, the hydraulic fluid filter must be changed.
	Warning symbol, air filter	If the symbol is shown when the engine is running at full speed, the air filter must be cleaned or replaced.
	Warning symbol, battery charging	If the symbol is shown when the engine is running, then the alternator is not charging. Stop the engine and locate the fault.
	Warning symbol, engine temperature	If this symbol is shown, the engine is too hot. Stop the engine immediately and locate the fault. Refer also to the engine manual.
	Warning symbol, hydraulic fluid temperature	This symbol is shown when the hydraulic fluid is too hot. Do not drive the roller; allow the fluid to cool by running the engine on idle, and then locate the fault.
	Warning symbol, low fuel level	This symbol is shown when the fuel level is 10%.
	Warning symbol, low sprinkler water level	This symbol is shown when the sprinkler water level is 10% in the main tank.
	Warning symbol, low braking capacity	This symbol is shown when the oil level for the brakes is low and/or if there is low brake pressure. If this alarm is shown and remains after starting the machine, or is shown during operation, stop and switch off the machine immediately and contact Service.
	Warning symbol. Error: [xx]	This symbol is shown when there is an alarm from the H1-AC unit. Error codes as per table H1-AC Alarm.



Alarms received are saved/logged and can be seen by selecting Display alarms.

 Selection of Display alarms.

### "ENGINE ALARM"

Saved/Logged engine alarms.



### "MACHINE ALARM"

Saved/Logged machine alarms. These alarms come from the other systems on the machine.



### "MAIN MENU"

In the main menu it is also possible to change some user and machine settings, access the service menu for calibration purposes (special service personnel only, requires pin code), and to see the version of installed software.





**"USER SETTINGS"**

Users can change the light settings, choose between the Metric or Imperial system, and set warning sounds On/Off.



Adjustment of the light and contrast settings on the display, including brightness of the panel light.





### "MACHINE SETTINGS"

The selection "Sprinkler Pump: 1 & 2" is in machine settings.

If the machine is fitted with double sprinkler pumps (Option) this is the menu in which the selection is made for which of the sprinkler pumps are to be activated to water the drum(s).



If the machine is fitted with accessories, e.g. a Chip spreader, the settings for these can also be changed.

### "WORKMODE SETTINGS"

This section is protected by Pin Code

There are 3 different modes that can be selected in the machine's workmode. (Soft, Medium, Hard).

The machine alerts at startup when the setting is in Soft Mode.



### "SERVICE MENU"

The service menu is also accessible via the main menu for adjustments.





**"ADJUSTMENTS"**

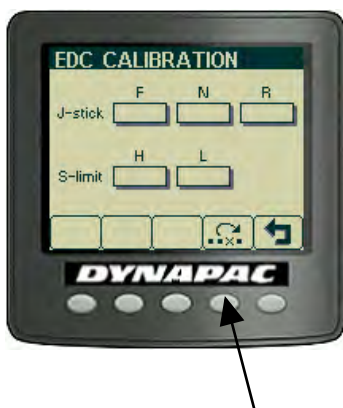
"TESTMODES" - Installation personnel only, requires pin code.



**"CALIBRATION"** - service personnel only, requires password.

"EDC Calibration" used to calibrate the joystick and speed potentiometer.

"TX Program" only used to change software in the display and requires special equipment and know-how.



**"EDC CALIBRATION"**

To calibrate, move the joystick fully forward (F) and press in both black buttons on the top of the joystick. (See also manual W3025)

Continue in the same way with the other positions for the joystick (N), (R) and the speed potentiometer.

Press the disk button to save the values.



### "ABOUT"

It is also possible to see the version of the installed software.



### Operator help when starting

When trying to start the machine without having set one, two or three of the conditions required to start machine, the missing conditions are shown in the display.

The missing conditions must be set before it is possible to start the machine.

Conditions that must be set:

- Activated P-brake
- Selector lever in neutral
- Speed selector for diesel engine in low (Low = idling) (not all models)



### Operator help Workmode

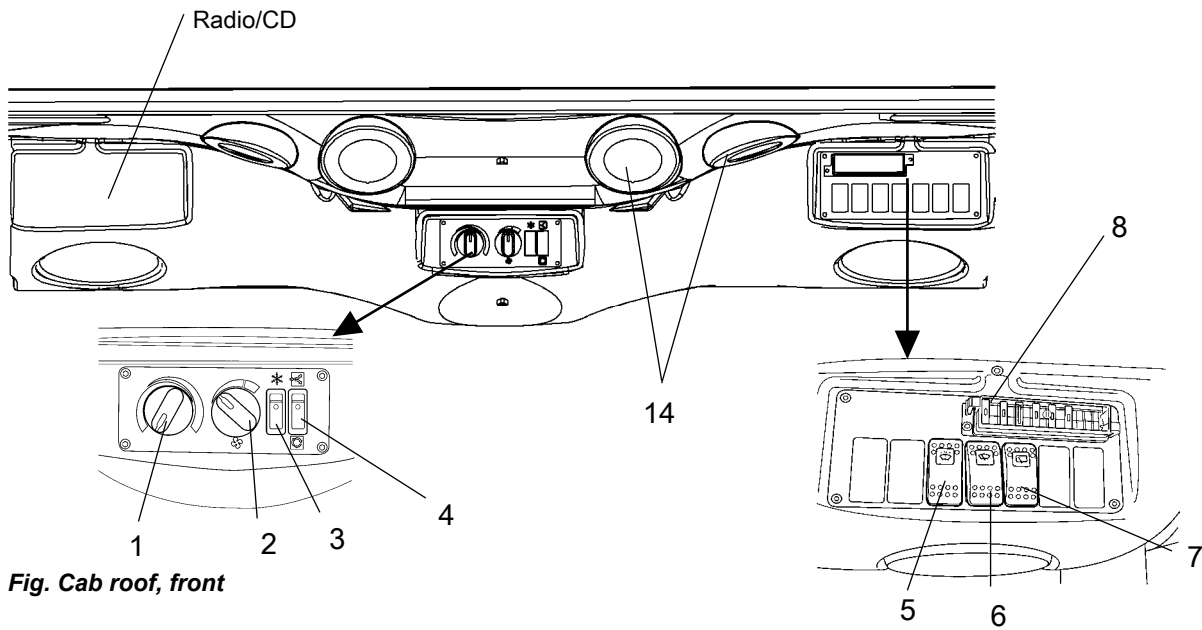
When attempting to activate

- Vibration
- Offset control (Option)
- Edge cutter/compactor (Option)

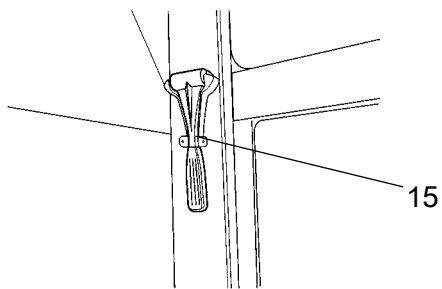
with the machine in Transport mode the display will show "Workmode" for a few seconds.

To activate the above functions it is necessary to make sure that the machine's Workmode is activated.

**Instruments and controls, cab**












**Fig. Cab roof, front**



**Fig. Right rear cab post**  
**15. Hammer for emergency exit**



**Function description of instruments and controls in the cab**

No	Designation	Symbol	Function
1	Heater control		Turn to the right to increase heating. Turn to the left to reduce heating.
2	Ventilation fan, switch		In the left position, the fan is off. Turning the knob to the right increases the volume of air entering the cab.
3	Air conditioning, switch		Starts and stops the air conditioning.
4	Cab air recirculation, switch		Pressing the top opens the air damper so that fresh air comes into the cab. Pressing the bottom closes the damper so that the air recirculates inside the cab.
5	Front wiper, switch		Press to operate the front screen wiper.
6	Front and rear window screen washers, switch		Press the upper edge to activate the front screen washers. Press the lower edge to activate the rear screen washers.
7	Rear wiper, switch		Press to operate the rear screen wiper.
8	Fuse box		Contains fuses for the electrical system in the cab.
14	Defroster nozzle		Turn the nozzle to direct the flow of air.
15	Hammer for emergency exit		To escape from the cab in an emergency, release the hammer and break the opening windows on the right-hand side.

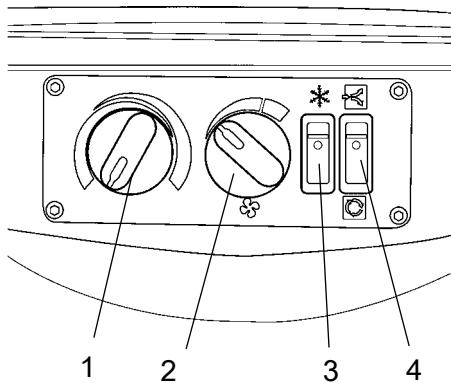
### Using the cab controls.

#### Defroster

To quickly remove ice or mist, make sure that only the front and rear air nozzles are open.

Turn the heater and fan dial (1 and 2) to max.

Adjust the nozzle so that it blows on the window to be de-iced, or to remove mist.



#### Heat

If the cab is cold, open the lower nozzle on the front columns and the middle nozzles just over the controls for the heater and fan.

Turn to max heat and max fan speed.

When the required temperature has been reached, open the other nozzles and if necessary turn down the heat and fan speed.

#### AC/ACC

**NOTE:** When using AC/ACC all the windows must be closed for the system to work efficiently.

To quickly reduce the temperature in the cab, adjust the following settings on the control panel.

Turn on AC/ACC (3) and set the fresh air (4) in the lower position to switch off the fresh air valve.

Set the heater control (1) to minimum and turn up the fan speed (2). Keep only the front middle nozzles in the ceiling open.

When the temperature has dropped to a comfortable level, adjust the required temperature on the heater control (1) and reduce the fan speed (2).

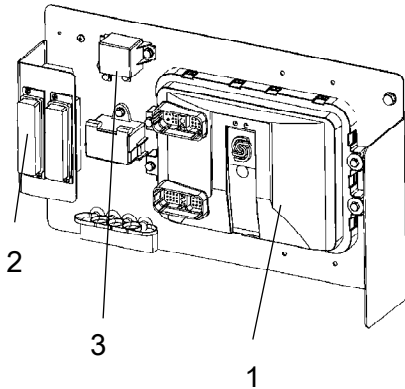
Now open the remaining nozzles in the roof to achieve a comfortable temperature in the cab.

Reset the fresh air button (4) to the upper position for fresh air.

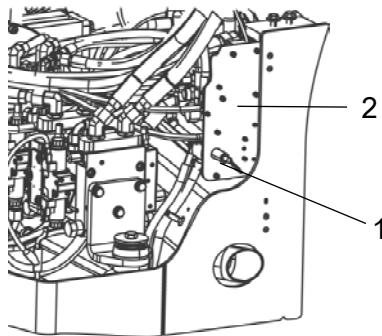
## Electrical system

The machine's main switchbox (1) is located on the rear of the operator platform. There is a plastic cover over the distribution box and fuses.

On the plastic cover there is a 24V socket.



**Fig. Main electrical central**  
1. Control unit (ECU)  
2. Fuses  
3. Main relay



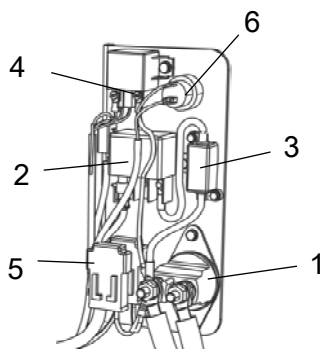
**Fig. Battery bay**  
1. Master switch  
2. Main fuse panel

The fuses in the engine compartment are located alongside the master switch.

The roller is equipped with 24 V electrical system and an AC alternator.



**Connect the correct polarities (ground) to the battery. The cable between the battery and the alternator must not be disconnected when the engine is running.**



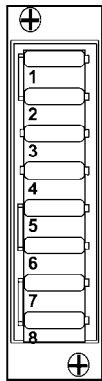
**Fig. Main fuse panel**  
1. Battery disconnecter  
2. Preheating relay (100A)  
3. Fuse (F21) (125A)  
4. Starter relay (50A)  
5. Fuses (F13, F10, F22)  
6. Power socket 24V

The main fuse panel is located behind the left engine compartment door.

The fuses are placed in the order shown below, starting by the plate.

F13	Engine ECU	(30A)
F10	Main fuse	(50A)
F22	Cab	(50A)

**Fuses**



**Fig. Fuse box**

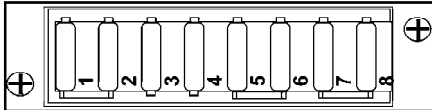
The figure shows the position of the fuses.

The table below gives fuse amperage and function. All fuses are flat pin fuses.

<b>Fuse box (F1)</b>			
1.	Main relay (F1.1)	5A	5. Power group 3, Main ECU (F1.5) 20A
2.	Supply, Main ECU, I/O unit, Display (F1.2)	5A	6. Power group 4, Main ECU (F1.6) 20A
3.	Power group 1, Main ECU (F1.3)	10A	7. 24V outlet, Lighting for tachograph (F1.7) 10A
4.	Power group 2, Main ECU (F1.4)	10A	8. Accessory ECU, Driving lights (F1.8) 20A

**Fuses in cab**

The electrical system in the cab has a separate fuse box located on the front right side of the cab roof.



**Fig. Cab roof fuse box (F7)**

The figure shows fuse amperage and function.

All fuses are flat pin fuses.

1.	Interior lighting	10A
2.	CD/Radio	10A
3.	AC condensor	15A
4.	Cab fan	15A
5.	Windscreen wiper/washers, front	10A
6.	Windscreen wiper/washers, rear	10A
7.	Reserve	
8.	Reserve	

## Operation

### Before starting

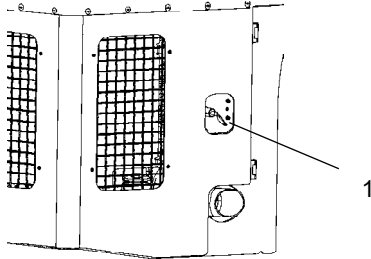
#### Master switch - Switching on

Remember to carry out daily maintenance. Refer to the maintenance instructions.

The master switch is located in the engine compartment. Turn the key (1) to the on position. The entire roller is now supplied with power.



**If the main battery/master switch is covered, the engine hood must be unlocked during operation, to be able to reach the switch in an emergency.**



**Figure. Engine door, left**  
**1. Battery disconnect**

#### Control panel, adjustments

The control unit has three adjustment options, transverse travel, rotation and steering column angle.

For transverse travel, raise the inner lever (1), which releases the catch.

For rotation, lift the outer lever (2). Ensure that the control unit locks in position before operating the machine.

Release locking lever (3) to adjust the steering column. Lock in the new position.

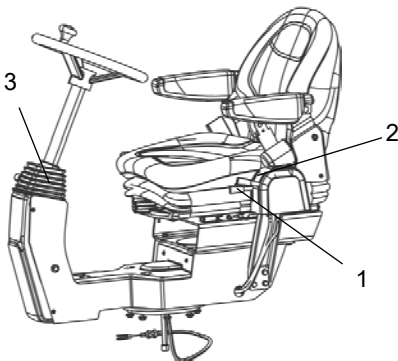
To adjust the operator's seat, see the section for basic/comfort seat.



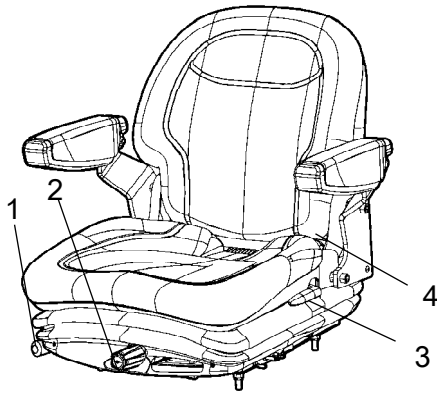
**Adjust all settings when the machine is stationary.**



**Always ensure that the seat is in locked position before operating the roller.**



**Fig. Operator position**  
**1. Locking lever - transverse travel**  
**2. Locking lever - rotation**  
**3. Locking lever - steering column angle**



**Fig. Operator's seat**  
1. Lock pack- Length adjustment  
2. Weight adjustment  
3. Back support angle  
4. Seat belt

### Operator's seat - Adjustment

Adjust the operator's seat so that the position is comfortable and so that the controls are within easy reach.

The seat can be adjusted as follows.

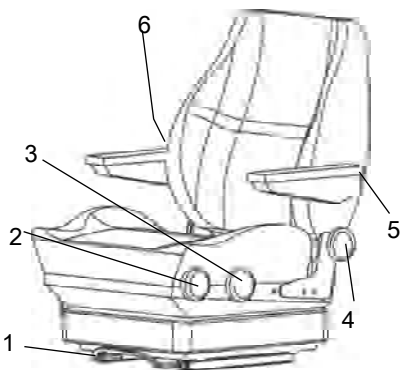
- Length adjustment (1)
- Weight adjustment (2)
- Back support angle (3)



**Always make sure that the seat is secure before beginning operation.**



**Do not forget to use the seatbelt (4).**



**Fig. Operator's seat**  
1. Lever - length adjustment  
2. Wheel - height adjustment  
3. Wheel - seat cushion inclination  
4. Wheel - backrest inclination  
5. Wheel - armrest inclination  
6. Wheel - lumbar support adjustment

### Operator's seat, comfort - Adjustments

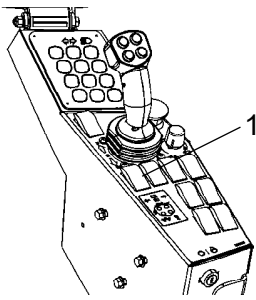
Adjust the operator's seat so that the position is comfortable and so that the controls are within easy reach.

The seat can be adjusted as follows:

- Length adjustment (1)
- Height adjustment (2)
- Seat-cushion inclination (3)
- Backrest inclination (4)
- Armrest inclination (5)
- Lumbar support adjustment (6)



**Always ensure that the seat is locked in position before operating the roller.**



**Fig. Control panel**  
1. Parking brake control

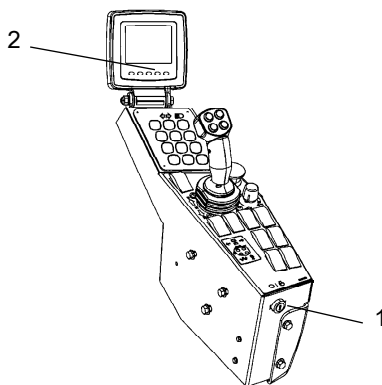
### Parking brake



**Make sure that the parking brake button (1) really is in the depressed position. The roller can start to roll when the engine is started on sloping ground, if the parking brake is not applied.**

Brake is always activated in Neutral position.  
(automatic 2 sec.)

**The parking brake must be activated to start the machine!**



**Fig. Control panel**  
1. Ignition key  
2. Status screen

### Display - Control

Sit down for all operations.

Turn the ignition key (1) to position I, the start screen will be shown in display.



**Fig. Status screen**  
3. Fuel level  
4. Water level  
5. Hour meter  
6. Voltmeter

Check that the voltmeter (6) shows at least 24 volts and the levels for fuel (3) and water (4) indicates a percentage value.

The hourmeter (5) registers and shows the total number of hours the engine has run.

### **Interlock**

The roller is equipped with Interlock.

The diesel engine will switch off after 7 seconds if the operator gets off the seat when going forwards/backwards.

If the control is in neutral when the operator stands up a buzzer will go on until the parking brake button is activated.

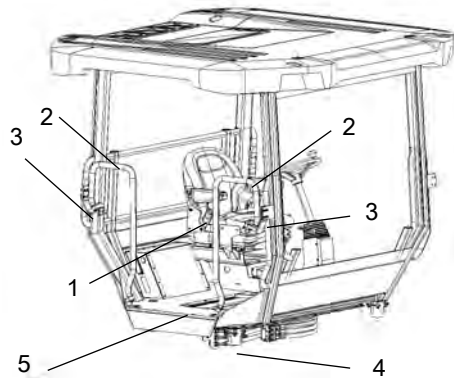
If the parking brake is activated, the diesel engine will not stop if the forward/reverse lever is moved out of neutral.

The diesel engine will switch off immediately if for any reason the forward/reverse lever is moved out of neutral when the operator is not sitting down and the parking brake button has not been activated.



***Sit down for all operations!***





**Fig. Operator position**  
1. Seat belt  
2. Safety railing  
3. Locking knob  
4. Rubber element  
5. Anti-slip

### Operator position

If a ROPS (Roll Over Protective Structure) or a cab is fitted to the roller, always wear the seat belt (1) provided and wear a protective helmet.



**Replace the seat belt (1) if it shows signs of wear or has been subjected to high levels of force.**



The safety rails (2) around the cab are adjustable in the inner and the outer positions. Pull in the rails when driving close to walls or other obstacles, and when transporting the machine.

Release the locking knob (3), set the the railings in the required position and relock in position.



Check that the rubber elements (4) on the platform are intact. Worn elements will reduce comfort.



**Ensure that the anti-slip (5) on the platform is in good condition. Replace where anti-slip friction is poor.**

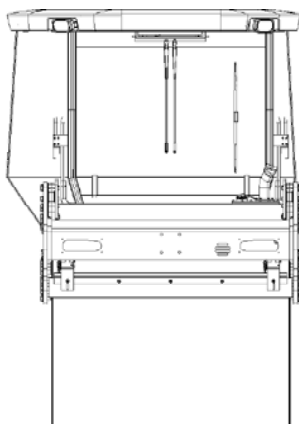


**If the machine is fitted with a cab, make sure that the door is closed when in motion.**

### View

Before starting, make sure that the view forwards and backwards is unobstructed.

All cab windows should be clean and the rear view mirrors should be correctly adjusted.



**Fig. View**

## Starting

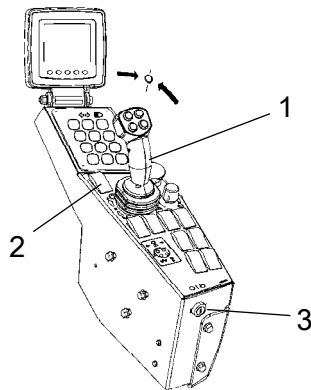
### Starting the engine

Make sure that the emergency stop is OFF and the parking brake ON.

Set the forward/reverse lever (1) in neutral position, and set the speed selector (2) in the idling position (LO).

**The diesel engine cannot be started in any other position of the controls.**

Turn the ignition key (3) right to position I and then engage the starter by turning it full right. Release back to I as soon as the engine starts.



**Fig. Control panel**  
1. F/R lever  
2. Rpm switch  
3. Ignition key



Do not run the starter motor for too long (max. 30 seconds). If the engine will not start, wait a minute before trying again.

At the start of the diesel engine when the ambient temperature is below +10 ° C (50 ° F), it must be warmed up at idle (low speed) until the hydraulic oil temperature exceeds +10 ° C (50 ° F).





**Ensure that there is good ventilation (air extraction) if the engine is run indoors. Risk of carbon monoxide poisoning.**




**Figure. Display - Status image**


Check during warming up of the engine that fuel and water levels are shown correctly and that the voltage is at least 24V.

 **When starting and driving a machine that is cold, remember that the hydraulic fluid is also cold and that braking distances can be longer than normal until the machine reaches the working temperature.**


 The machine always starts in the Transport position, without it being possible to use off-set, vibration or sprinkling.

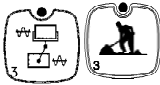
 **If the machine and drums are in off-set mode, switch to work mode and reset before loading the machine on a truck. This is indicated by a warning in the display.**


**Display when activating choice via the button set.**




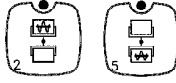
The parking symbol is shown when the parking brake is activated.





 = Operating position, off-set, vibration and sprinkling possible. The symbol flashes in off-set mode, in neutral (reset off-set) the symbol shines constantly.

 = Automatic Water Control (AWC), sprinkling is activated when the F/R lever is outside neutral.






 = High amplitude

 = Vibration on front and rear drum.

 = Automatic Vibration Control (AVC), vibration is activated when the F/R lever is outside neutral.


 = Display of alarm, see table for information.

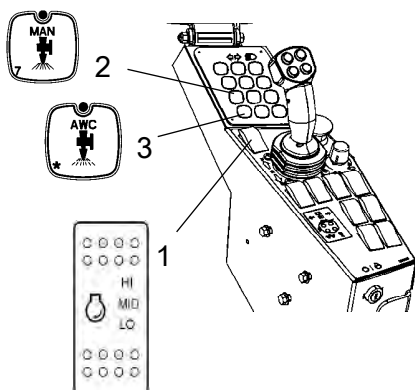
### Alarm descriptions

Symbol	Designation	Function
	Warning lamp, hydraulic filter	If the lamp comes on while the engine is running at full speed, the hydraulic filter must be changed.
	Warning lamp, air filter	If the lamp comes on while the engine is running at full speed, the air filter must be cleaned or replaced.
	Warning lamp, battery charging	If the lamp comes on while the engine is running, the alternator is not charging. Stop the engine and locate the fault.
	Warning light, engine temperature	If the lamp comes on, the engine is too hot. Stop the engine immediately and locate the fault. Refer also to the engine manual.
	Warning lamp, hydraulic fluid temperature	If the lamp comes on, the hydraulic fluid is too hot. Do not drive the roller. Cool the fluid by allowing the engine to idle and locate the fault.

### Driving

#### Operating the roller

 **Under no circumstances is the machine to be operated from the ground. The operator must be seated inside the machine during all operation.**




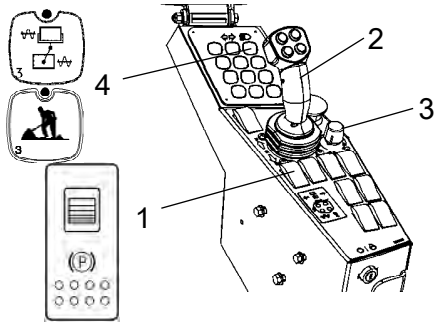
**Fig. Control panel**  
1. Rpm switch  
2. Manual sprinkler  
3. Automatic sprinkler

Activate working revs = HI (1).

Check that the steering is working correctly by turning the steering wheel once to the right and once to the left while the roller is stationary.

When compacting asphalt, don't forget to turn on the sprinkling system (2) alt. (3).

 **Make sure that the area in front of and behind the roller is clear.**



**Fig. Control panel**  
1. Parking brake  
2. F/R lever  
3. Speed control  
4. Working mode



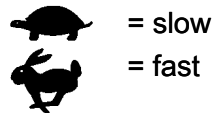
**Release the parking brake button (1) by sliding the red lock on the button backwards and changing the position of the lever. Remember that the roller can start rolling, if it is on a slope.**

**Machine with gear change in the speed potentiometer.**

Activate the button to get Working mode (4).

Position the speed control (3) in suitable position, 0-12 km/h (0-8 mph).

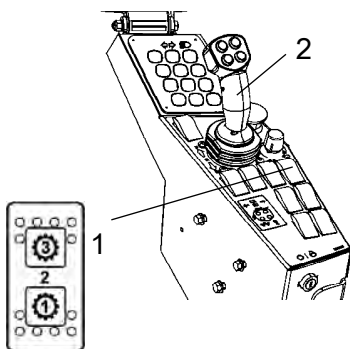
The machine's gear position is shown in the center of the speedometer. Select the gear/speed for the task:



**Figure. The display shows the selection in the middle (tortoise or rabbit).**

Carefully move the forward/reverse lever (2) forwards or backwards, depending on which direction of travel is required.

Speed increases as the lever is moved away from the neutral position.



**Fig. Control panel**  
1. Gear position switch  
2. Forward/Reverse lever

**Machine with gear change in separate 3-position switch (gear position switch)**

Position 1: Used for maximum hill-climbing capacity during vibratory compaction

Position 2: Normal position

Position 3: Used for maximum transport speed or for high speed during smooth rolling without vibration

Carefully move the forward/reverse lever (2) forwards or backwards, depending on which direction of travel is required.

The speed increases as the lever is moved away from the neutral position.



The speed should always be controlled using the forward/reverse lever and never by changing the engine speed.



**Check that the secondary brake is working by depressing the button (1) when the roller is mowing SLOWLY forward.**

### Interlock/Emergency stop/Parking brake - Check



**The interlock, emergency stop and parking brake must be checked daily before operating. A function check of the interlock and emergency stop requires a restart.**



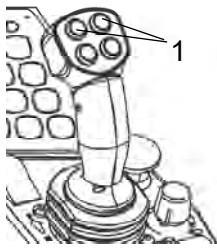
**The interlock function is checked by the operator standing up from the seat when the roller is moving very slowly forwards/backwards. (Check in both directions). Hold the steering wheel firmly and brace yourself for a sudden stop. A buzzer goes on and after 7 seconds the engine switches off and the brakes are activated.**



**Check the function of the emergency stop by pressing the emergency stop button when the roller is moving slowly forwards/backwards. (Check in both directions). Hold the steering wheel firmly and brace yourself for a sudden stop. The engine switches off and the brakes are activated.**



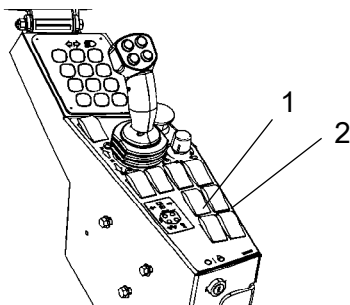
**Check the function of the parking brake by activating the parking brake when the roller is moving very slowly forwards/backwards. (Check in both directions). Hold the steering wheel and brace yourself for a sudden stop when the brakes are activated. The engine does not switch off.**



**Fig. F/R lever**  
**1. Offset steering**



**Figure. Display**



**Figure. Switch**  
**1. Edge cutter/compactor Up/Down**  
**2. Sprinkler, edge cutter/compactor**

### **Pivotal steering (Optional)**

The machine must be in the operating position to activate the pivotal steering. Use the two front buttons (1) on the forward/reverse lever to operate the pivotal steering.

To reset the rear drum to neutral, adjust the buttons (1) until the display (2) shows that the machine has aligned the drums.

The symbol for Work mode shines continuously in neutral (drums in line)

If fault indication on the display is shown or if the buzzer sounds, stop immediately the roller in a safe place and shut off the Diesel engine. Check the cause for failure and remedy, see also maintenance manual, trouble shooting guide or engine manual.

### **Edge cutting (Optional)**

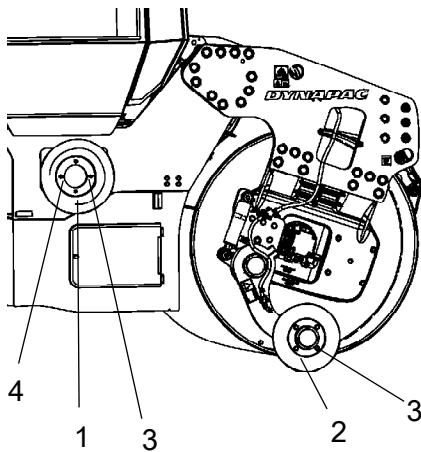
The machine must be running to activate the edge cutter/compactor.

When the machine is in the operating position and the switch (1) is pressed at the bottom, the edge cutter/compactor is lowered to the asphalt surface by means of a hydraulic cylinder. To reset the edge cutter/compactor in its original position, press the top of the switch to lift the edge cutter/compactor.

The edge cutter/compactor can also be lifted if the machine is in transport position.

A bypass valve prevents the hydraulic system being overloaded.

There is a separate sprinkler system which the operator should use to avoid asphalt sticking to the edge cutter/compactor. The system is operated with a switch (2). The water is drawn from the main water tank, which is also used for the normal sprinkler system.



**Fig. Changing the tool**  
 1. Edge compactor  
 2. Edge cutter  
 3. Bolted joint  
 4. Holder for cutter/compactor wheel

The operator can choose between two tools, the edge cutter or edge compactor. The edge cutter (1) in the figure is shown in the operating position. The edge compactor (1) can easily be replaced with the edge cutter by releasing the bolted joint (3).

## Vibration

### Manual/Automatic vibration

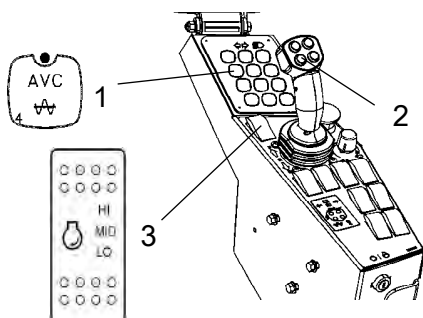
Manual or automatic vibration activation/deactivation is selected using button (1).

In the manual position, the operator activates vibration using the switch (2) on the forward/reverse lever.

In the automatic position (AVC), vibration is activated when the pre-set speed is reached. Vibration is automatically deactivated when the lowest pre-set speed is reached.

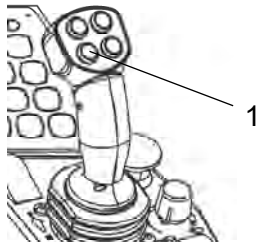
Activation of vibration for the first time, as well as disconnection of automatic vibration, are performed with the switch (2) on the forward/reverse lever.

**Note that vibration can only be activated when the operating position is activated, and when the rpm switch (3) for the engine is in high (HI).**



**Figure. Control panel**  
 1. Automatic vibration control (AVC)  
 2. Switch, vibration On/Off  
 3. Rpm switch





**Fig. F/R lever**  
**1. Vibration ON/OFF**

**Manual vibration - Switching on**

**!** Never activate vibration when the roller is stationary. This can damage both the surface and the machine.

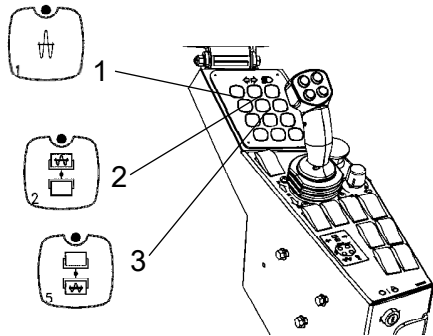
Engage and disengage vibration using the switch (1) on the front of the forward/reverse lever.

Always switch off vibration before the roller comes to a standstill.

When compacting thin layers of asphalt up to approx. 50 mm (2 inches) thick, the best results are achieved with low amplitude/high frequency.

**Amplitude/frequency - Changeover**

**!** The amplitude setting must not be change when vibration is in operation  
Switch the vibration off and wait until vibration stops before changing amplitude.



**Fig. Control panel**  
**1. High amplitude**  
**2. Vibration fron drum**  
**3. Vibration rear drum**

By pressing button (1) high amplitude is achieved.

The buttons (2) and (3) are used to get vibrations either on front or rear drum or on both.

- (2) vibration on front drum.
- (3) vibration on rear drum.

**Braking**

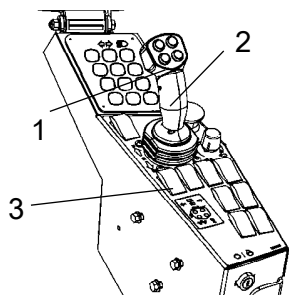
**Normal braking**

Press the switch (1) to switch off the vibration.

Move the forward/reverse lever (2) to the neutral position to stop the roller.

Always press down the parking brake knob (3), before leaving the operator platform.

**!** **When starting and driving a machine that is cold, remember that the hydraulic fluid is also cold and that braking distances can be longer than normal until the machine reaches the working temperature.**



**Fig. Control panel**  
**1. Vibration On/Off switch**  
**2. Forward/Reverse lever**  
**3. Parking brake button**

If the forward/reverse lever is moved quickly (forwards or backwards) toward/past neutral, the system switches to a rapid braking Mode and the machine stops.

Activate normal driving Mode again by moving the forward/reverse lever back to neutral.

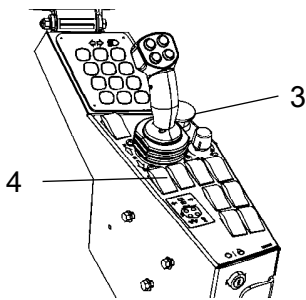
### Emergency braking

Braking is normally activated using the forward/reverse lever. The hydrostatic transmission retards and slows the roller when the lever is moved towards the neutral position.

A disc brake in each drum motor/drum gear and the rear axle also acts a secondary brake when in motion, and as a parking brake when stationary. Activated with the parking brake control (4) in the right-hand position.



**For emergency braking, press the emergency stop (3), hold the steering wheel firmly and be prepared for a sudden stop. The engine stops.**



**Fig. Control panel**  
3. Emergency stop  
4. Parking brake

The Diesel engine will stop and must be restarted.

After emergency braking, return the forward/reverse lever to neutral and deactivate the emergency stop.

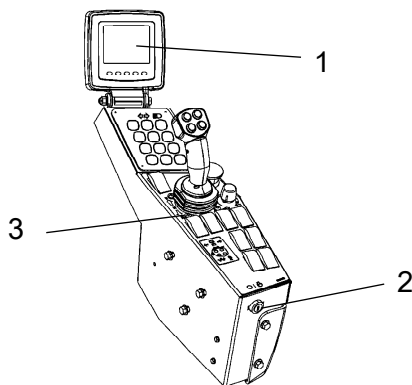
### Switching off

Set the speed control in idling position and allow the engine to idle for a few minutes to cool down.

Check the display to see if any faults are indicated. Switch off all lights and other electrical functions.

Activate the parking brake knob (3) and then turn the ignition lock (2) to the left to the off position.

Fit the instrument cover on the display and top of the control box (on rollers without cab), and lock it.



**Fig. Control panel**  
1. Display  
2. Ignition lock  
3. Parking brake knob

## Parking

### Chocking the drums



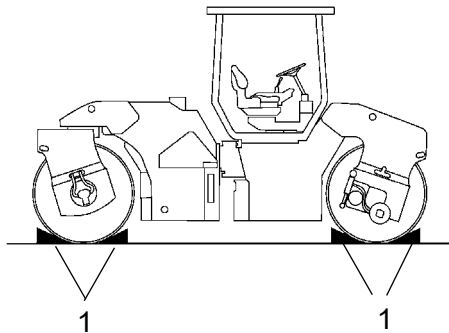
**Never disembark from the machine when the diesel engine is running, unless the parking brake is activated.**



**Make sure that the roller is parked in a safe place with respect to other road users. Chock the drums if the roller is parked on sloping ground.**



Keep in mind that there is a risk of freezing during the winter. Drain the water tanks, pumps and water lines. Fill antifreeze in the engine cooling system and the washer fluid reservoir in the cab. Also see maintenance instructions.



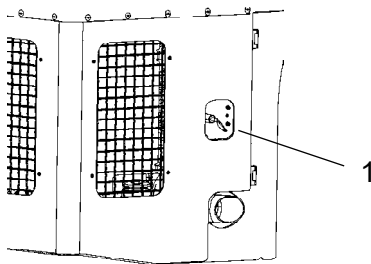
**Fig. Positioning**  
**1. Chocks**

### Master switch

Before leaving the roller for the day, switch the master switch (1) to the disconnected position and remove the handle.



Before switching off the battery isolation switch, wait for at least 30 seconds after the ignition lock has been switched off, in order to avoid the engine's electronic control unit (ECU) sustaining damage.



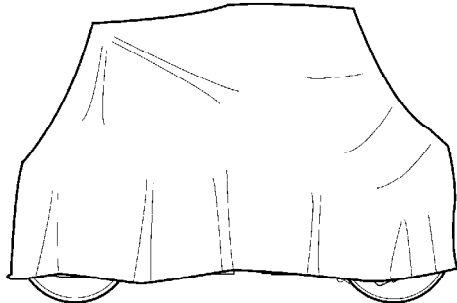
**Figure. Engine door, left**  
**1. Battery disconnect**

This will prevent battery discharging and will also make it difficult for unauthorized persons to start and operate the machine. Lock the service doors/covers.



## Long-term parking

**!** The following instructions should be followed when long term parking (more than one month).



**Fig. Roller weather protection**

These measures apply when parking for a period of up to 6 months.

Before re-commissioning the roller, the points marked with an asterisk \* must be returned to the pre-storage state.

Wash the machine and touch up the paint finish to avoid rusting.

Treat exposed parts with anti-rust agent, lubricate the machine thoroughly and apply grease to unpainted surfaces.

### Engine

\* Refer to the manufacturer's instructions in the engine manual that is supplied with the roller.

### Battery

\* Remove the battery/batteries from the machine, clean the outside and trickle charge once a month.

### Air cleaner, exhaust pipe

\* Cover the air cleaner (see under the heading 'Every 50 hours of operation' or 'Every 1000 hours of operation') or its opening with plastic or tape. Also cover the exhaust pipe opening. This is to avoid moisture entering the engine.

### Watering system

\* Empty the water tank and all hoses of water. Empty the filter housing and the water pump. Undo all sprinkler nozzles.

See maintenance sections for "Watering system - draining".

### Fuel tank

Fill the fuel tank completely full to prevent condensation.

### Hydraulic reservoir

Fill the hydraulic reservoir to the uppermost level mark (see under the heading 'Every 10 hours of operation.')

### **Hoods, tarpaulin**

\* Lower the instrument cover over the instrument panel.

\* Cover the entire roller with a tarpaulin. A gap must be left between the tarpaulin and the ground.

\* If possible, store the roller indoors and ideally in a building where the temperature is constant.

### **Steering cylinder, hinges, etc.**

Grease the steering cylinder piston with conservation grease.

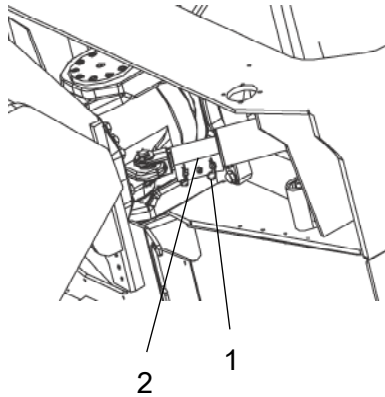
Grease the hinges on the doors to the engine compartment and the cab.

## Miscellaneous

### Lifting

#### Locking the articulation

 **Articulation must be locked to prevent inadvertent turning before lifting the roller.**



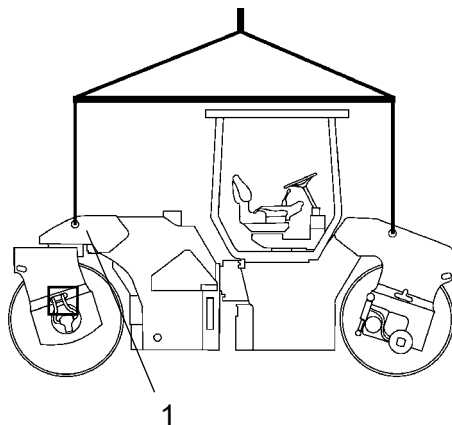
**Figure. Articulation in locked position**  
1. Cotter pin  
2. Lock

Turn the steering wheel so the roller is straight forward.

Press down the parking brake button and switch off the machine.

Put the locks on the guide cylinder piston rods and lock them.


Weight: refer to the hoisting plate on the roller




**Fig. Roller prepared for lifting**  
1. Hoisting plate

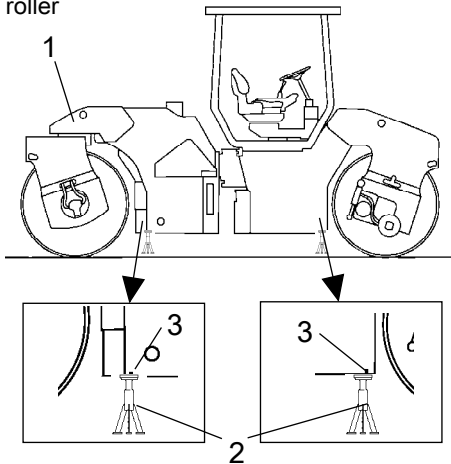
#### Lifting the roller

 **The machine's gross weight is specified on the hoisting plate (1). Refer also to the Technical specifications.**

 Lifting equipment such as chains, steel wires, straps and lifting hooks must be dimensioned in accordance with the relevant safety regulations for the lifting equipment.

 **Stand well clear of the hoisted machine! Make sure that the lifting hooks are properly secured.**

Weight: refer to the hoisting plate on the roller



**Figure. Roller lifted with jack**  
1. Lifting plate  
2. Jack  
3. Marking

**Lifting the roller with jack:**



**The machine's gross weight is specified on the hoisting plate (1). Refer also to the Technical specifications.**



The lifting device such as a jack (2), or equivalent, must be dimensioned according to the safety regulations for lifting devices.



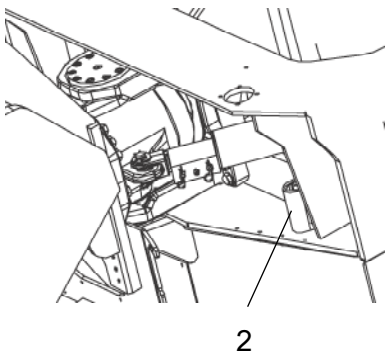
**Do not go under a lifted load! Make sure that the lifting device is secure in its position, and on a level and stable surface.**

The machine **must only be lifted** with a jack, or the like, positioned as per the **markings (3)**. The frame is reinforced at these points to withstand the tension. Lifting at any other place can result in damage to the machine or personal injury.

**Unlocking the articulation**



Remember to unlock the articulation before operating.



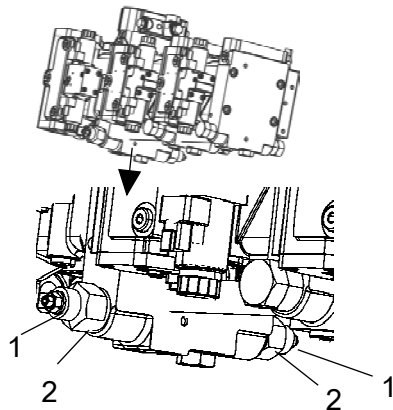
**Figure. Articulation in open position**  
2. Lock

Insecure and remove the locking devices and put them in the storing place.

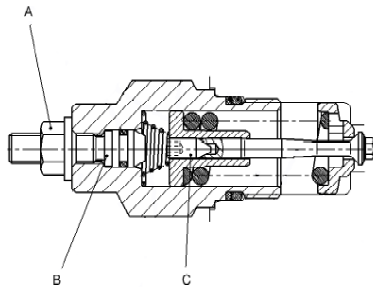
**Towing/Recovering**

The roller can be moved up to 300 meters (1,000 ft) using the instructions below.

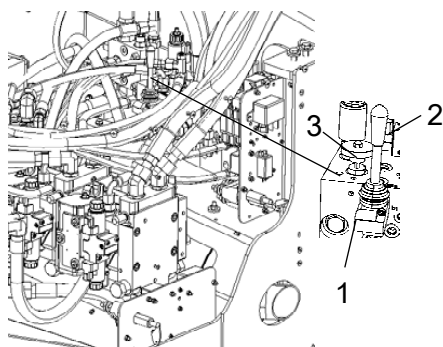




**Fig. Propulsion pump**  
1. Towing valve  
2. Bypass valve



**Figure. Towing valve**



**Fig. Brake disengagement valve**  
1. Valve  
2. Pump arm  
3. Knob

**Short distance towing with the engine running**

**!** *Activate the parking brake knob, and temporarily stop the diesel engine. Chock the drums to prevent the roller from moving*

Open the left door to the engine compartment to access the propulsion pump.

Turn both towing valves (1) (middle hexagonal nuts A) three turns to the left, while holding the bypass valve (2) (lower hexagonal nuts). The valves are located at the bottom of the propulsion pump.

After releasing the hex nut (A), screw in the adjusting screw (B) until it touches the pin (C) and then turn an additional ½ turn. The valve is now open.

To leave the by-pass position, unscrew the adjusting screw (B) until it stops and then lock the valve again with the hex nut (A).

Start the engine and allow it to idle.

Deactivate the parking brake knob and place the forward/reverse lever in the forward or reverse position. If the lever is in neutral, the brakes in the hydraulic motors are activated.

The roller can now be towed and can also be steered if the steering system is otherwise functioning.

**Short distance towing when the engine is inoperative.**

**!** *Chock the drums to prevent the roller from moving when the brakes are hydraulically disengaged.*

Open both towing valves as described earlier.

The brake disengagement pump is located behind the left door of the engine compartment.

Make sure that the valve (1) is closed, this is done by tightening clockwise with the knob (3). Pump with the pump arm (2) until the brakes are disengaged.

Ensure that the valve is reset into open position after finished towing. This is done by turning the knob counter clockwise to full extracted position.

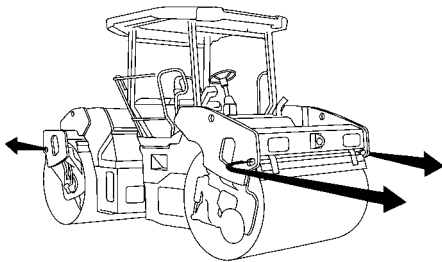
**Towing the roller**



*When towing/recovering, the roller must be braked by the towing vehicle. A towing bar must be used as the roller has no brakes.*



The roller must be towed slowly, max. 3 km/h (2 mph) and only towed short distances, max. 300 m (1000 ft).



**Fig. Towing**

When towing/retrieving a machine, the towing device must be connected to both lifting holes in the diagram.

Pulling forces should act parallel to the machine's longitudinal axis, as illustrated. See table below for maximum permitted pulling force for machine model.

Model	kN	lbf
CC424HF	150	33 750
CC524HF	180	40 500
CC624HF	190	42 750

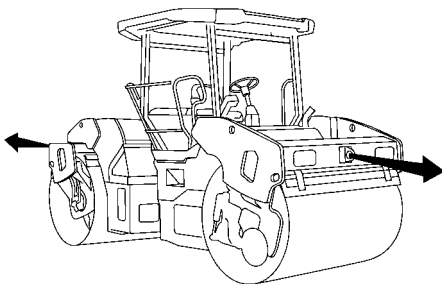


Reverse the towing preparations made to the hydraulic pump and/or the motor.

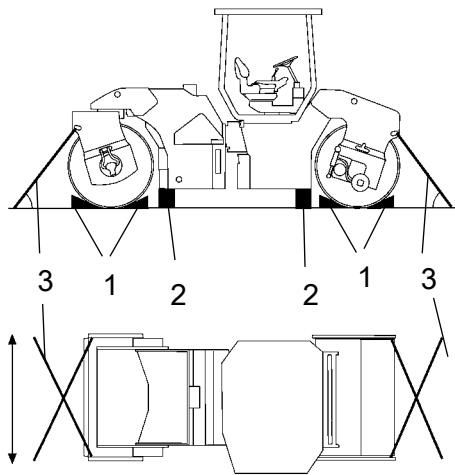
**Trailer eye**

The roller can be fitted with a trailer eye.

The trailer eye is not designed to be used for towing/recovering. It is designed for trailers and other towed objects weighing no more than 2 600 kg (5 750 lbs).



**Fig. Trailer eye**



**Fig. Positioning**

1. Chocks
2. Blocks
3. Straps

### Roller prepared for transport



**Lock the articulation before lifting and transporting. Follow the instructions under the relevant heading.**

Activate the parking brake.

Make sure that the machine is in a neutral position, i.e. that the drums are in line.

Chock the drums (1) and secure the chocks to the transport vehicle. The chock should have an angle of 37° and minimum height of 25 cm (9.9 inches). The drums should be chocked both forwards and backwards.

Block up under the drum frame (2), to avoid overloading on the rubber suspension of the drum when lashing. Block up the machine as shown in figure

Secure the roller with chains in all four corners. The attachment points are shown on the decals. Place the chains in symmetrical pairs crossing each other.



**Make sure that the chains, blocks and attachments in the transport vehicle are approved and have the requisite breaking strain. Check at regular intervals that the chains are not slack.**



**Remember to return the articulation to its unlocked position before starting the roller.**



**Operating instructions - Summary**



1. **Follow the SAFETY INSTRUCTIONS specified in the Safety Manual.**
2. Make sure that all instructions in the MAINTENANCE section are followed.
3. Turn the master switch to the ON position.
4. Move the forward/reverse lever to the NEUTRAL position. Sit down in the seat.
5. Engage the parking brake.
6. Disengage the emergency stop. The roller is always starting in transportation mode.
7. Set the engine revs control button in position idle.
8. Start the engine and allow it to warm up.
9. Set the engine revs control button in position working speed.
10. Disengage the parking brake.



11. **Drive the roller. Operate the F/R lever with care.**



12. **Test the brakes. Remember that the braking distance will be longer if the hydraulic fluid is cold.**

13. Set the transportation/working mode button in position working mode.
14. Use vibration only when the roller is in motion.
15. Check that the drums are thoroughly watered when watering is required.



16. **IN AN EMERGENCY:**
  - **Press the EMERGENCY STOP.**
  - **Hold the steering wheel firmly.**
  - **Brace yourself for a sudden stop.**
17. When parking:
  - Activate the parking brake.
  - Switch off the engine and block the drums if the roller is on an inclined surface.
18. When lifting: - Refer to the relevant section in the Instruction Manual.
19. When towing: - Refer to the relevant section in the Instruction Manual.
20. When transporting: - Refer to the relevant section in the Instruction Manual.

**21.** When recovering - Refer to the relevant section in the Instruction Manual.

### Preventive maintenance

Complete maintenance is necessary for the machine to function satisfactorily and at the lowest possible cost.

The Maintenance section includes the periodic maintenance that must be carried out on the machine.

The recommended maintenance intervals assume that the machine is used in a normal environment and working conditions.

### Acceptance and delivery inspection

The machine is tested and adjusted before it leaves the factory.

On arrival, before delivery to the customer, delivery inspection must be conducted as per the check list in the warranty document.

Any transport damage must be immediately reported to the transport company.

### Warranty

The warranty is only valid if the stipulated delivery inspection and the separate service inspection have been completed as per the warranty document, and when the machine has been registered for starting under the warranty.

The warranty is not valid if damage has been caused by inadequate service, incorrect use of the machine, the use of lubricants and hydraulic fluids other than those specified in the manual, or if any other adjustments have been made without the requisite authorisation.





**Maintenance - Lubricants and symbols**

**Fluid volumes**

<b>Drum</b>		
- Drum	14 liters	15 qts
- Drum gear	1,5 liters	1.6 qts
Hydraulic reservoir	40 liters	42 qts
<b>Diesel engine</b>		
- oil	11 liters	11.6 qts
- coolant, no cab	21,4 liters	22.6 qts
- coolant, with cab	23,6 liters	25.0 qts







Always use high-quality lubricants and the amounts recommended. Too much grease or oil can cause overheating, resulting in rapid wear.







Other fuel and lubricants are required when operating in areas with extremely high or extremely low ambient temperatures. See the 'Special instructions' chapter, or consult Dynapac.

**DYNAPAC/AtlasCopco**

















 ENGINE OIL	Air temperature -15°C - +50°C (5°F-122°F)	Shell Rimula R4 L 15W-40, API CH-4 or equivalent.	<b>AtlasCopco Engine 100</b> , P/N 5580020624 (5 liters)
 HYDRAULIC FLUID	Air temperature -15°C - +50°C (5°F-122°F)	Shell Tellus S2 V68 or equivalent.	<b>AtlasCopco Hydraulic 300</b> , P/N 9106230330 (20 liters)
	Air temperature over +40°C (104°F)	Shell Tellus S2 V100 or equivalent.	
 BIOLOGICAL HYDRAULIC FLUID <small>Bio-Hydr.</small>	When it leaves the factory, the machine may be filled with biologically degradable fluid. The same type of fluid must be used when changing or topping up.	BP BIOHYD SE-S 46	
BIOLOGICAL HYDRAULIC FLUID, PANOLIN	Air temperature -10°C - +35°C (14°F-95°F) When it leaves the factory, the machine may be filled with biologically degradable fluid. The same type of fluid must be used when changing or topping up.	PANOLIN HLP Synth 46 (www.panolin.com)	
 DRUM OIL	Air temperature -15°C - +40°C (5°F-104°F)	Mobil SHC 629	<b>Dynapac Drum Oil 1000</b> , P/N 4812156456 (5 liters), P/N 4812156457 (20 liters)

## Maintenance - Lubricants and symbols

### DYNAPAC/AtlasCopco

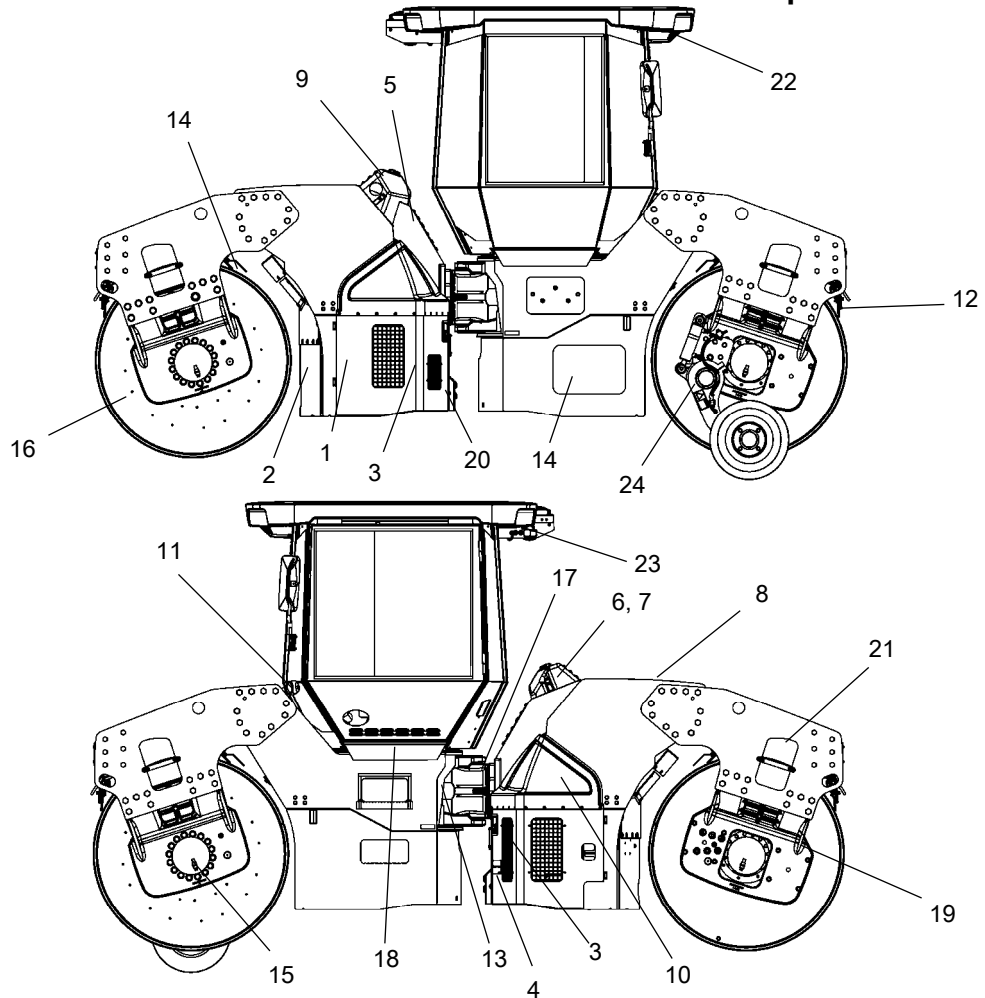
 GREASE		Shell Retinax LX2 or equivalent.	<b>Dynapac Roller Grease</b> (0.4kg), P/N 4812030095
 FUEL	See engine manual.	-	-
 TRANSMISSION OIL	Air temperature -15°C - +40°C (5°F-104°F)	Shell Spirax S3 AX 80W/90, API GL-5 or equivalent	<b>Dynapac Gear oil 300</b> , P/N 4812030756 (5 liters), P/N 4812030117 (20 liters), P/N 4812031574 (209 liters)
	Air temperature 0°C (32°F) - above +40°C (104°F)	Shell Spirax S3 AX 85W/140, API GL-5 or equivalent.	
 COOLANT	Anti-freeze protection down to about -37°C (-34.6°F)	GlycoShell/Carcoolant 774C or equivalent, (mixed 50/50 with water)	

### Maintenance symbols

	Engine, oil level		Air filter
	Engine, oil filter		Battery
	Hydraulic reservoir, level		Sprinkler
	Hydraulic fluid, filter		Sprinkler water
	Drum, oil level		Recycling
	Lubricating oil		Fuel filter
	Coolant level		Pump gear, oil level
	Air pressure		Sprinkler, tires

**Maintenance - Maintenance schedule**

**Service and maintenance points**




**Fig. Service and maintenance points**


- |                             |                            |                     |
|-----------------------------|----------------------------|---------------------|
| 1. Engine oil               | 9. Coolant                 | 17. Steering joint  |
| 2. Oil filter               | 10. Air cleaner            | 18. Seat bearing    |
| 3. Fuel filter              | 11. Refueling point        | 19. Rubber element  |
| 4. Hydraulic filter         | 12. Scrapers               | 20. Battery         |
| 5. Hydraulic fluid level    | 13. Water tank(s), filling | 21. Pivot bearing   |
| 6. Hydraulic fluid, filling | 14. Watering system        | 22. Cab, air filter |
| 7. Hydraulic tank cap       | 15. Drum gear              | 23. Cab, AC         |
| 8. Hydraulic fluid cooler   | 16. Drum oil               | 24. Edge cutter     |

## Maintenance - Maintenance schedule

### General

Periodic maintenance should be carried out after the number of hours specified. Use the daily, weekly etc. periods where number of hours cannot be used.

 Remove all dirt before filling, when checking oils and fuel and when lubricating using oil or grease.

 The manufacturer's instructions found in the engine manual also apply.

### Every 10 hours of operation (Daily)

Refer to the contents to find the page number of the sections referred to !

Pos. in fig	Action	Comment
	<b>Before starting up for the first time on that day</b>	
1	Check the engine oil level	Refer to the engine manual
9	Check the engine coolant level	
5	Check the hydraulic reservoir level	
11	Refuel	
13	Fill the water tanks	
14	Check the sprinkler system	
14	Check the Emergency watering (Extra pump in pump system)	
12	Check the scraper setting	

### After the FIRST 50 hours of operation

Refer to the contents to find the page number of the sections referred to !

Pos. in fig	Action	Comment
1,2	Change the engine oil and oil filter	Refer to the engine manual
3	Change the fuel filter	Refer to the engine manual
4	Change the hydraulic fluid filter	Refer to 1000h.
15	Change the oil in the drum gears	Refer to 1000h.

## Maintenance - Maintenance schedule

### Every 50 hours of operation (Weekly)

Refer to the contents to find the page number of the sections referred to !

Pos. in fig	Action	Comment
10	Inspect/clean the filter element in the air cleaner	Replace as required
15	Check the oil level in the drum gears	
3	Draining the fuel prefilter	
22,23	Inspect the air conditioning	Optional
24	Inspect/lubricate the edge cutter	Optional

### Every 250 hours of operation (Monthly)

Refer to the contents to find the page number of the sections referred to !

Pos. in fig	Action	Comment
8	Clean the hydraulic fluid cooler/water cooler	Or when required
22,23	Check the AC	Optional
20	Check the batteries condition.	

### Every 500 hours of operation (Every three months)

Refer to the contents to find the page number of the sections referred to !

Pos. in fig	Action	Comment
1,2	Change the diesel engine oil and oil filter *)	Refer to the engine manual
3	Change the engine fuel filter	Refer to the engine manual
3	Change the engine pre-filter	
16	Check the oil level in the drums	
21	Lubricate the pivot bearings	Optional
19	Check rubber elements and bolted joints	
7	Check the hydraulic reservoir cover/breather	
18	Grease the chair bearing	
	*) Only applicable for correct fuel quality, otherwise change every 250 hours.	

## Maintenance - Maintenance schedule

### Every 1000 hours of operation (Every six months)

Refer to the contents to find the page number of the sections referred to !

Pos. in fig	Action	Comment
	Check engine valve clearances	Refer to the engine manual
	Check the engine belt drive system	Refer to the engine manual
10	Replace the air cleaner's main filter and backup filter.	
4	Change the hydraulic fluid filter	
16	Change the oil in the drums	
15	Change the oil in the drum gears	
22	Replace the air cleaner filter in the cab	

### Every 2000 hours of operation (Yearly)

Refer to the contents to find the page number of the sections referred to !

Pos. in fig	Action	Comment
6	Change the hydraulic fluid	
11	Drain and clean the fuel tank	
13	Drain and clean the water tanks	
17	Check the condition of the articulation	
23	Overhaul the air conditioning	Optional

## Maintenance, 10h



**Park the roller on a level surface. The engine must be switched off and the parking brake activated when checking or adjusting the roller, unless otherwise specified.**



**Ensure that there is good ventilation (air extraction) if the engine is run indoors. Risk of carbon monoxide poisoning.**

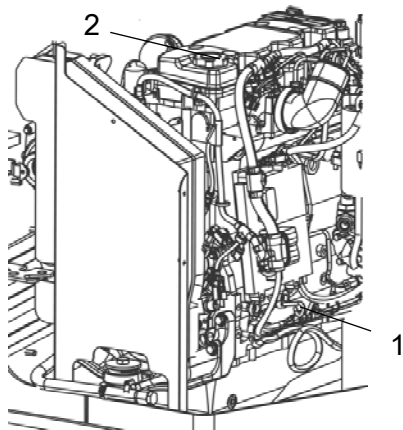


### Diesel engine - Check oil level

The dipstick is accessed through the right door of the engine compartment.



**Take care not to touch any hot parts of the engine or the radiator when removing the dipstick. Risk of burns.**



**Fig. Engine compartment**  
1. Dipstick  
2. Oil filler cap

The dipstick is located down on the front of the engine.

Pull out the dipstick (1) and check that the oil level is between the upper and lower marks.

For further details, refer to the engine's instruction manual.



### Coolant level - Check

Check that the coolant level is between the max. and min. marks (2).

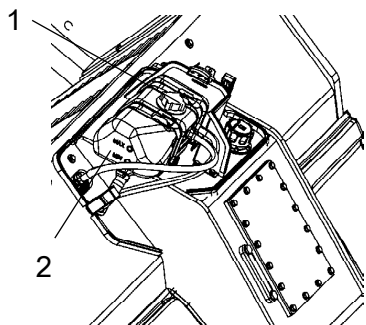


**Observe great caution if the cap has to be opened while the engine is hot. Wear protective gloves and goggles.**

Fill with a mixture of 50% water and 50% anti freeze. See the lubrication specification in these instructions and the engine manual.



Flush the system every other year and change the coolant. Also check that the air has unobstructed passage through the reservoir.



**Fig. Expansion tank**  
1. Filler cap  
2. Level marks



### Fuel tank - Refueling

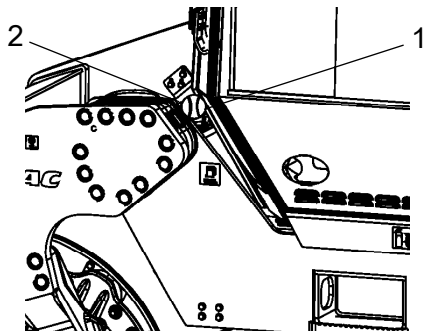


**Never refuel while the engine is running. Do not smoke and avoid spilling fuel.**

The filler pipe and tank cap are on the left side of the front frame.

Refuel the tank every day before starting work, or fill the tank at end of work. Unscrew the lockable tank cap (1) and fill fuel up to the lower edge of the filler pipe.

The tank holds 230 liters (60.7 gal) of fuel. Refer to the engine manual for information on diesel grade.

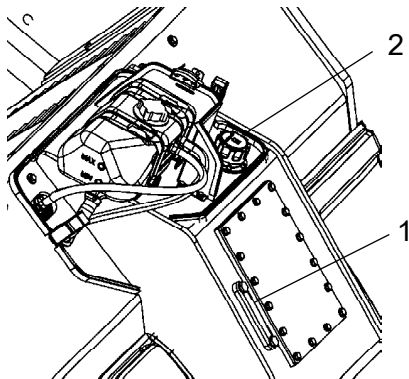


**Fig. Fuel tank**  
1. Tank cap  
2. Filler pipe





### Hydraulic reservoir - Check fluid level

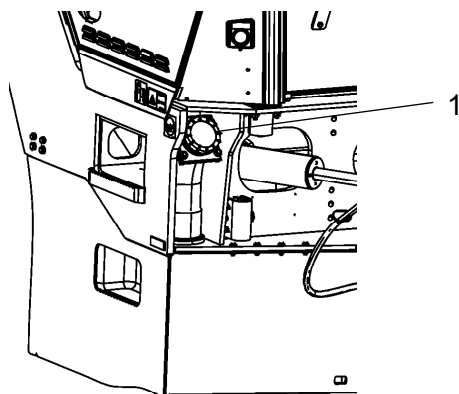


**Figure. Hydraulic reservoir**  
1. Oil sight glass  
2. Filler cap

Place the roller on a level surface and check that the oil level in the sight glass (1) is between the max and min markings. Top up with the type of hydraulic fluid specified in the lubricant specification, if the level is too low.



### Water tank, Std - Filling



**Figure. Standard water tank**  
1. Tank cap

The filler cap is on the rear left side of the front frame.

The machine can also be fitted with refilling on both sides.

When quick-filling on a machine with two filling pipes, loosen the filler cap on the nonfilling side to ventilate the water tank.



Unscrew the tank cap (1) and fill with clean water. Do not remove the strainer (2).

Fill the central (standard) tank, it holds 900 liters (238 gal).



Only additive: A small amount of environment-friendly antifreeze.



### Sprinkler system/Drum Check

Start the sprinkler system and make sure that none of the nozzles (1) are clogged. If necessary, clean blocked nozzles and the coarse filter placed by the water pump (2). See next section.

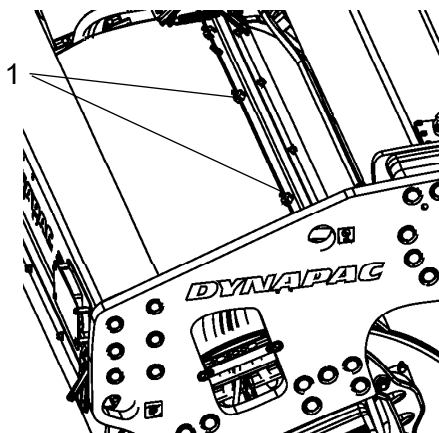


Figure. Front drum  
1. Nozzle

### Cleaning the coarse filter

To clean the coarse filter (1) open the drain cock (3) on the filter and allow any dirt to run out.

If necessary close the cock (2) and clean the filter and filter housing. Check that the rubber gasket in the filter housing is intact.

After inspecting and cleaning, reset and start the system to check that it works.

There is a drain cock (5) in the space for the pump system. This can be used to drain the tank and the pump system.

An extra pump (6) can be installed in case the standard water pump stops working. See section for emergency watering.

To drain the complete sprinkler system, see section for Watering system - Draining, 2,000 h.

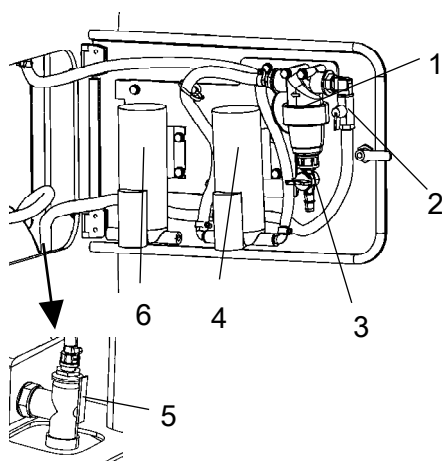
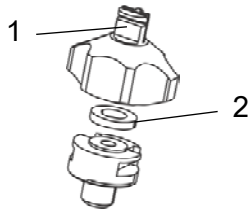


Figure. Pump system, front frame  
right side

- 1. Coarse filter
- 2. Stop cock
- 3. Drain cock kran, filter
- 4. Water pump
- 5. Drain cock
- 6. Extra pump (optional)



**Figure. Nozzle**  
1. Sleeve, nozzle, filter  
2. Packing

### Sprinkler system/Drum Cleaning of sprinkler nozzle

Dismantle the blocked nozzle by hand.

Blow the nozzle and fine filter (1) clean using compressed air. Alternatively, fit replacement parts and clean the blocked parts later on.

Nozzle	Colour	Ø (mm)	l/min (2.0 bar)	gal/min (40 psi)
Standard	yellow	0.8	0.63	0.20
Option	blue	1.0	1.00	0.31
Option	red	1.2	1.25	0.39
Option	brown	1.3	1.63	0.50

After inspecting and carrying out any necessary cleaning, start the system and check that it works.



**Wear protective goggles when working with compressed air.**

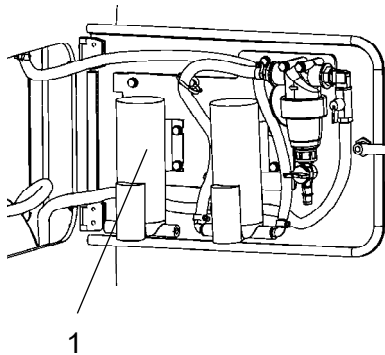


### Emergency watering (Accessory) - Extra pump in pump system

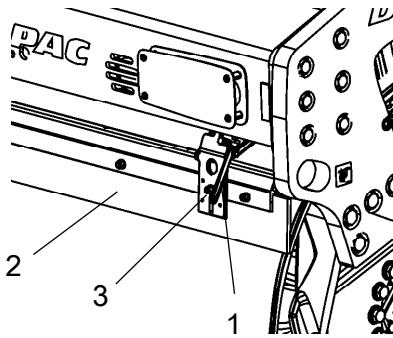
If the water pump stops, an extra pump will keep the sprinkler system in operation.

Connect the electric cable and water hoses to the extra pump instead of the standard pump.

The water hoses are connected to the pump with quick couplings to simplify draining and where appropriate replacement to a reserve pump (option).



**Figure. Panel on right side of front frame**  
1. Extra pump



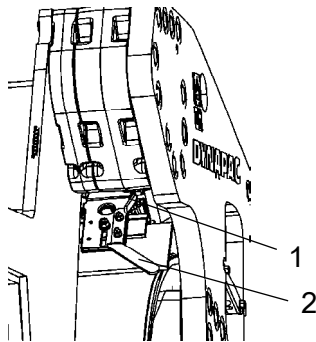
**Figure. Outer scrapers**  
1. Release arm  
2. Scraper blade  
3. Adjusting screw

**Scrapers, spring-action  
Check**

Make sure that the scrapers are undamaged.

Release with the arm (1).

Loosen the screws (3) to adjust the scraper blade up or down.



**Figure. Inner scrapers**  
1. Release arm  
2. Lifting handle

Asphalt remnants can accumulate on the scraper and affect the contact force. Clean when necessary.



The scrapers must be retracted from the drum during transport driving.

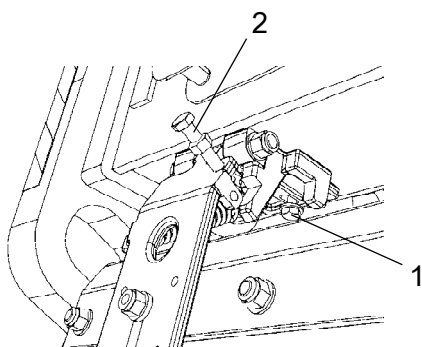
**Scrapers  
Setting - Adjustment**

Release the retaining unit (1) for the scraper bracket and unscrew the adjusting screw (2) to release.

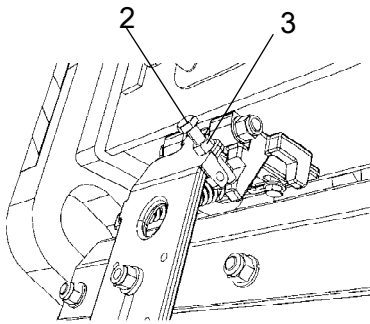
Push in the scraper bracket and tighten.

Adjust the screw (2) so that the scraper blade lies approx. 2 mm (0.08 in) from the drum on the same side as the screw.

Adjust the scraper bracket in or out on the other side so that there is an equal gap between the scraper blade and drum, and tighten the retaining unit (1).



1-2 mm  
(0.04-0.08 in)



**Figure. Scraper setting**  
**1. Retaining unit**  
**2. Adjusting screw**  
**3. Lock nut**

The adjusting screw (2) is adjusted until the scraper blade has a gap of approx. 1 mm (0.04 in) to the roller, or lies loosely on the roller, along its entire length.

Tighten the lock nut (3).



## Maintenance - 50h



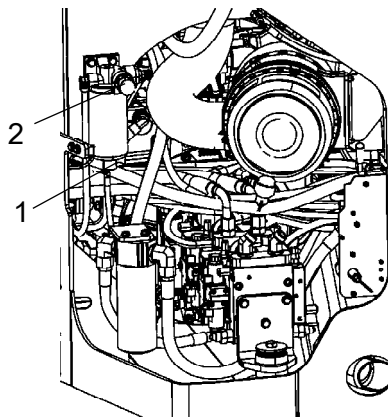
**Park the roller on a level surface. The engine must be switched off and the parking brake activated when checking or adjusting the roller, unless otherwise specified.**



**Ensure that there is good ventilation (air extraction) if the engine is run indoors. Risk of carbon monoxide poisoning.**



### Fuel filter - Draining



**Figure. Fuel filter**  
**1. Drain plug**  
**2. Hand pump**

Unscrew the drain plug (1) at the bottom of the fuel filter.

With the aid of the secondary hand-operated pump, make certain that all sediment comes out. See Cummins service manual.

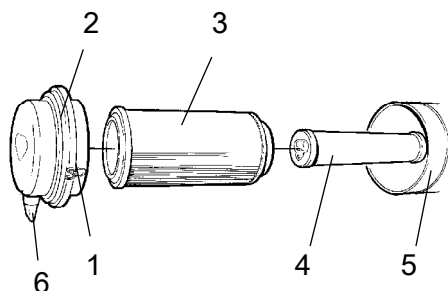
Tighten the drain plug as soon as uncontaminated fuel runs out.



### Air cleaner Checking - Change the main air filter



Change the air cleaner's main filter when the warning lamp on the display lights when the diesel engine is operating at full speed.



**Fig. Air cleaner**  
1. Clips  
2. Cover  
3. Main filter  
4. Backup filter  
5. Filter housing  
6. Dust valve

Release the clips (1), pull off the cover (2), and pull out the main filter (3).

Do not remove the backup filter (4).

Clean the air cleaner if necessary, see section Air cleaner - Cleaning.

When replacing the main filter (3), insert a new filter and refit the air cleaner in the reverse order.

Check the condition of the dust valve (6); replace if necessary.

When refitting the cover, make sure that the dust valve is positioned downwards.

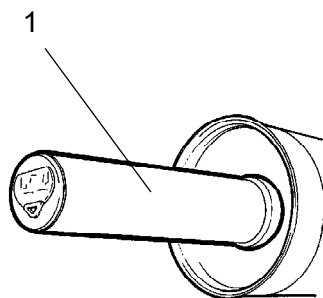


### **Backup filter - Change**

Change the backup filter with a new filter after every third replacement of the main filter.

To change the backup filter (1), pull the old filter out of its holder, insert a new filter and reassemble the air cleaner in the reverse order.

Clean the air cleaner if necessary, see section Air cleaner - Cleaning.



**Fig. Air filter**  
1. Backup filter

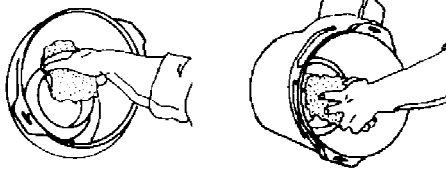




### Air cleaner - Cleaning

Wipe clean the inside of the cover (2) and the filter housing (5). See the previous illustration.

Wipe clean on both sides of the outlet pipe.



Inner edge of outlet pipe.

Outer edge of outlet pipe.

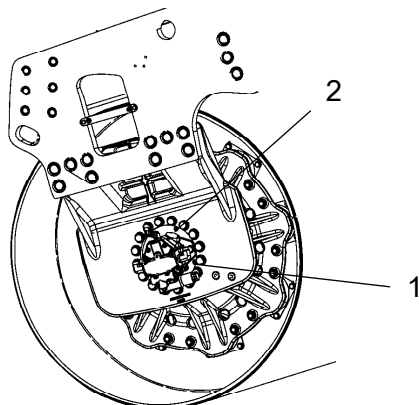
Wipe also both surfaces for the outlet pipe; see adjacent figure.



Check that the hose clamps between the filter housing and the suction hose are tight and that the hoses are intact. Inspect the entire hose system, all the way to the engine.



### Drum gear - Checking the oil level



**Fig. Oil level check - drum gear**  
1. Level plug  
2. Filling plug

Wipe clean the area around the level plug (1) and then undo the plug.

Ensure that the oil level reaches up to the lower edge of the plug hole.

Replenish the oil to the right level if the level is low. Use transmission oil, see lubricant specifications.

It may be necessary to remove the speed sensor when filling the front drum.

Clean and refit the plugs.

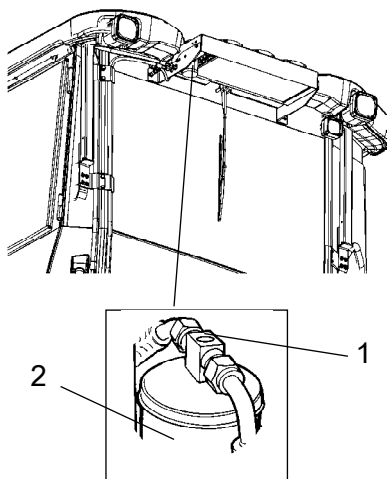


**Air conditioning (Optional)**

**- Inspection**



***Park the roller on a level surface, chock the wheels and depress the parking brake control.***



**Fig. Drying filter**  
1. Sight glass  
2. Filter holder

With the unit in operation, check using the sight glass (1) that bubbles are not visible on the drying filter.



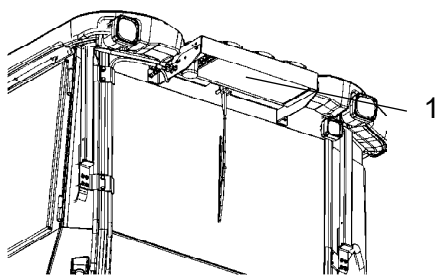
***Always depress the parking brake knob.***

The filter is located on the top of the rear part of the cab roof. If bubbles are visible through the sight glass, this is a sign that the refrigerant level is too low. Stop the unit to avoid risking damage. Fill up with refrigerant.



**Air conditioning (Optional)**

**- Cleaning**



**Fig. Cab**  
1. Condensor element

If there is a significant loss of cooling capacity, clean the condensor element (1) on the rear edge of the cab roof.

## Maintenance - 250h



**Park the roller on a level surface. The engine must be switched off and the parking brake activated when checking or adjusting the roller, unless otherwise specified.**



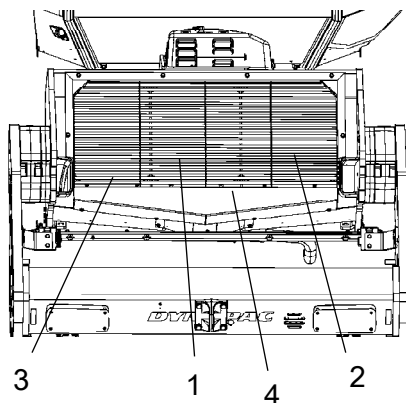
**Ensure that there is good ventilation (air extraction) if the engine is run indoors. Risk of carbon monoxide poisoning.**



### Hydraulic fluid cooler Checking - Cleaning

The water and hydraulic fluid coolers are accessible when the cooler grill (4) is removed.

Make sure that the air flow through the cooler is unobstructed. Dirty coolers are blown clean with compressed air or washed clean using a high-pressure water cleaner.



**Figure. Cooler**  
1. Charge air cooler  
2. Water cooler  
3. Hydraulic fluid cooler  
4. Cooler grill



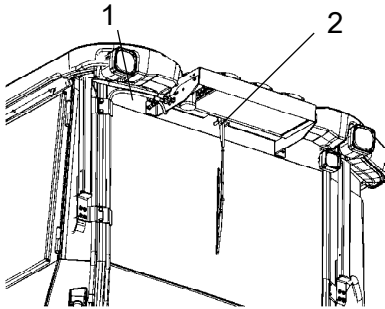
**Take care when using a high-pressure water jet. Do not hold the nozzle too near the cooler.**



**Wear protective goggles when working with compressed air or high-pressure water jets.**

**Air conditioning (Optional)  
- Inspection**

Inspect refrigerant hoses and connections and make sure that there are no signs of an oil film that can indicate a refrigerant leakage.



**Fig. Air conditioning**  
1. Refrigerant hoses  
2. Condenser element

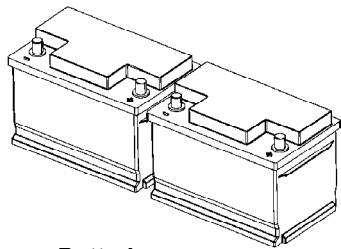


**Battery  
- Check condition**

The batteries are sealed and maintenance-free.



***Make sure there is no open flame in the vicinity when checking the electrolyte level. Explosive gas is formed when the alternator charges the battery.***



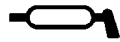
**Figure. Batteries**



**When disconnecting the battery, always disconnect the negative cable first. When connecting the battery, always connect the positive cable first.**

The cable shoes should be clean and tightened. Corroded cable shoes should be cleaned and greased with acid-proof Vaseline.

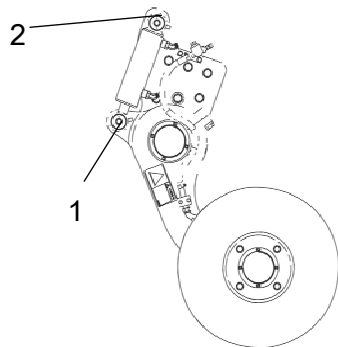
Wipe the top of the battery.



**Edge cutter (Optional)  
- Lubrication**



***Refer to the operation section for information on how to operate the edge cutter.***



***Figure. Two grease points for lubricating the edge cutter***

Grease the two points as shown in the figure.

Grease should always be used for lubrication, see the lubricant specifications.

Grease all bearing points with five strokes of a hand-operated grease gun.



## Maintenance - 500h



**Park the roller on a level surface. The engine must be switched off and the parking brake activated when checking or adjusting the roller, unless otherwise specified.**



**Ensure that there is good ventilation (air extraction) if the engine is run indoors. Risk of carbon monoxide poisoning.**



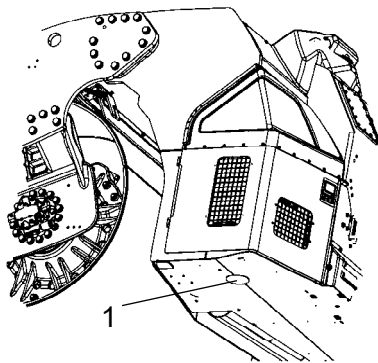
### Diesel engine Oil change

The engine's oil drain plug is located under the rear frame on the machine on the right side. The drain plug is accessed by first removing the rubber plug on the underside of the frame.

Drain the oil when the engine is warm. Place a receptacle that holds at least 14 liters (15 qts) under the drain plugs.



**Take great care when draining engine oil. Wear protective gloves and goggles.**



**Figure. Underside of rear frame  
1. Oil draining of diesel engine**

Unscrew the drain plug (1). Allow all the oil to drain out and refit the plug.



**Deliver the drain oil for environmentally correct handling.**

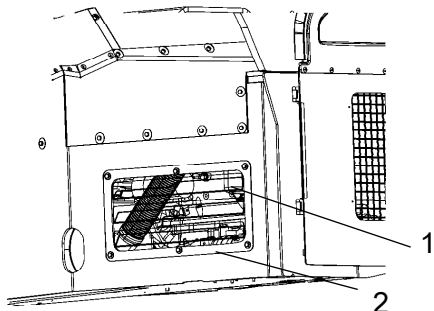
Fill with fresh engine oil, see Lubricant specification or the engine manual for the correct grade of oil.

Fill with the requisite volume of engine oil. See technical specifications before starting the machine. Allow the engine to idle for a few minutes, and then switch off the engine.

Check the dipstick to ensure that the engine oil level is correct. Refer to the engine manual for details. Top up with oil if necessary to the max mark on the dipstick.



### Engine Replacing oil filter



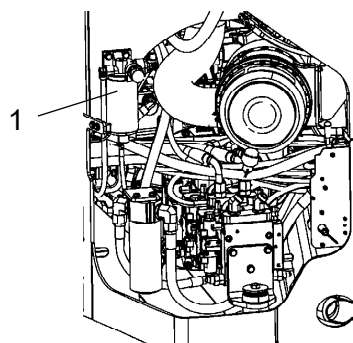
**Figure. Engine compartment, right side**  
1. Oil filter  
2. Service panel

The oil filter (1) is located at the back on the engine and can easily be accessed by removing the service panel on the right side between the rear frame and drum.

See the engine manual for information about replacing the filter.



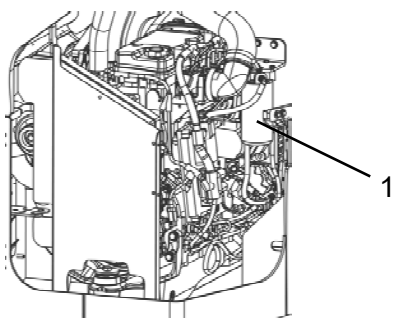
### The engine fuel filter - replacement/cleaning



**Figure. Engine compartment, left side**  
1. Prefilter

The fuel filter is placed on the left side of the engine compartment.

Unscrew the bottom and drain off any water, and then replace the filter unit.



**Figure. Engine compartment, right side.**  
1. Fuel filter

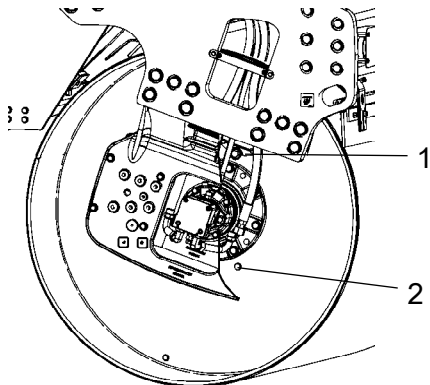
Replace the fuel filter, located on the right side of the engine compartment.

Start the engine and check that the filter is well sealed.





### **Drum - oil level Inspection - filling**



**Fig. Drum, vibration side**  
1. Filler plug  
2. Level plug

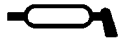
Position the roller with the filler plug (1), the large plug, at the highest point in its rotation.

Wipe clean around the level plug (2), the small plug, and remove the plug.

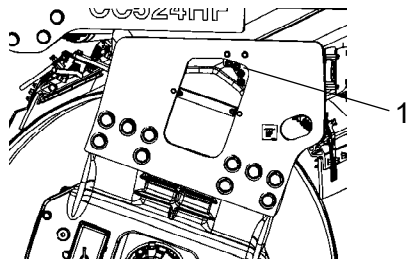
Make sure that the oil level is up to the lower edge of the hole. Top off with fresh oil if the level is low. Use oil as specified in the lubricants specification.

When removing the filler plug, wipe any metal accumulated on the plug magnet off. Make sure that plug seals are intact and replace with new seals if not.

Refit the plugs and check that they are tight by driving the roller and then rechecking.



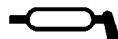
### **Pivot bearing (Optional) - Lubrication**



**Fig. Rear drum**  
1. Grease nipples x 4

Grease each nipple (1) with five strokes of a hand-operated grease gun.

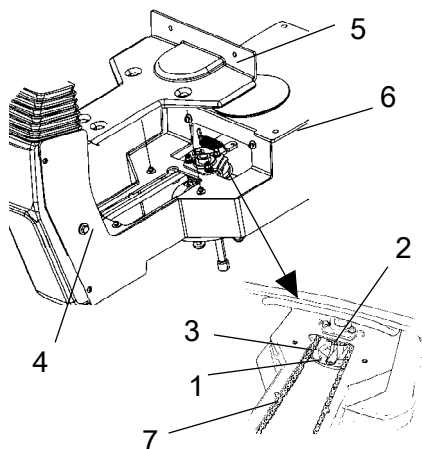
Use grease as specified in the lubricant specification.



### Seat bearing - Lubrication



Keep in mind that the chain is a vital part of the steering mechanism.



**Figure. Seat bearing**

- 1. Grease nipple
- 2. Gearwheel
- 3. Steering chain
- 4. Adjusting screw
- 5. Cover
- 6. Slide rails
- 7. Marking

Remove the cover (5) to access the lubrication nipple (1). Lubricate the operator seat slew bearing with three strokes of a hand-operated grease gun.

Clean and grease the chain (3) between the seat and the steering column.

Also grease the seat slide rails (6).

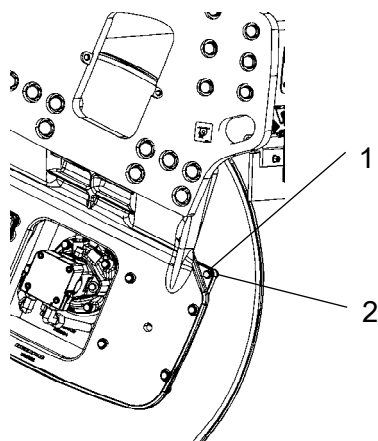
If the chain is slack on the sprocket (2), loosen the screws (4) and move the steering column forward. Tighten the screws and check chain tension.

Do not tension the chain too tightly. It should be possible to move the chain about 10 mm (0.4 in) to the side with a forefinger/thumb at the marking (7) in seat frame. Fit the chain lock at the bottom.



If the seat starts to be stiff when adjusting, it should be lubricated more often than specified here.

### Rubber elements and attachment screws Check



**Fig. Drum, vibration side**

- 1. Rubber element
- 2. Attachment screws

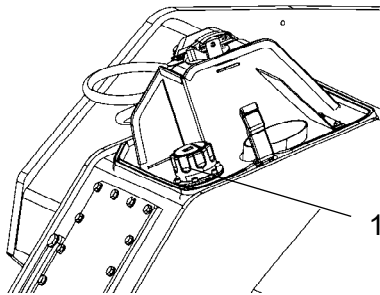
Check all rubber elements (1). Replace all elements if 25% or more than 25% of the number on one side of the drum have cracks deeper than 10-15 mm (0.4-0.6 in).

Check using a knife blade or pointed object.

Check also that the attachment screws (2) are tightened.



### Hydraulic reservoir cap - Check



**Figure. Rear frame front left side**  
**1. Hydraulic reservoir cap**

Turn up the machine so that the tank cap is accessible from the left side of the machine.

Unscrew and make sure that the reservoir cap is not clogged. Air must have unobstructed passage through the cap in both directions.


If passage in either direction is blocked, clean the filter with a little diesel oil and blow through with compressed air until the block is removed, or replace the cap with a new one.




***Wear protective goggles when working with compressed air.***



## Maintenance - 1000h

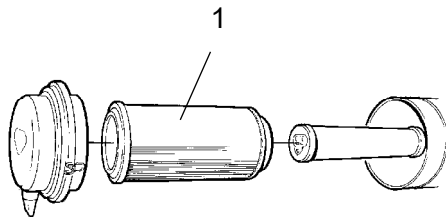
 **Park the roller on a level surface. The engine must be switched off and the parking brake activated when checking or adjusting the roller, unless otherwise specified.**

 **Ensure that there is good ventilation (air extraction) if the engine is run indoors. Risk of carbon monoxide poisoning.**




### Air filter - Change

Replace the main filter in the air cleaner (1). See under the heading 'Every 50 hours of operation' for information on changing the filter.



**Fig. Air cleaner**  
**1. Main filter**

 If a blocked filter is not replaced, the exhaust fumes will be black and the engine will lose power. There is also a risk of severe damage to the engine.

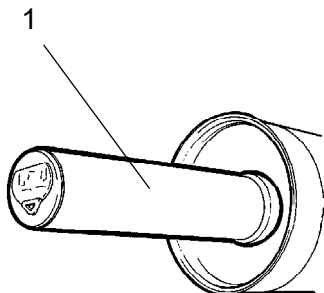


### Backup filter - Change

Change the backup filter with a new filter after every third replacement of the main filter.

To change the backup filter (1), pull the old filter out of its holder, insert a new filter and reassemble the air cleaner in the reverse order.

Clean the air cleaner if necessary, see section Air cleaner - Cleaning.



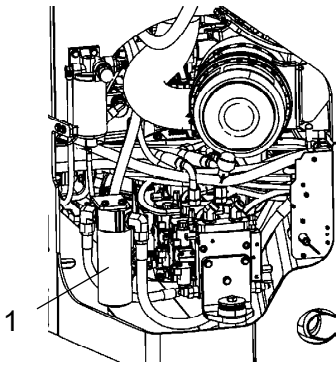
**Fig. Air filter**  
**1. Backup filter**



### Hydraulic filter Change



Remove the filter (1) and deliver to special waste handling. This is a single-use filter and cannot be cleaned.

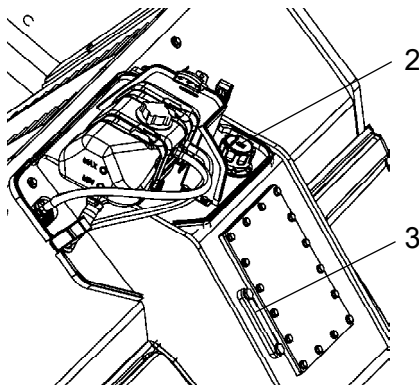


**Figure. Engine compartment, left**  
**1. Hydraulic fluid filter**

Thoroughly clean the filter holder sealing surface.

Apply a thin coat of fresh hydraulic fluid to the rubber gasket on the new filter.

Screw the filter on by hand, firstly until the filter gasket makes contact with the filter base. Then rotate a further  $\frac{1}{2}$  turn.



**Figure. Hydraulic tank**  
**2. Hydraulic reservoir cap**  
**3. Sight glass**

Check the hydraulic fluid level in the sight glass (3) and top off as required. See under the heading 'Every 10 hours of operation' for more information.

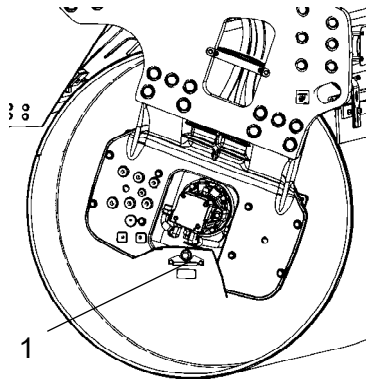
Start the engine and check that the filter does not leak.



### Drum - Oil change



**Take great care when draining the fluid. Wear protective gloves and goggles.**



**Fig. Drum, vibration side**  
**1. Drain plug**

Set the roller so that the drain plug (1), the large plug, is at the lowest position in its rotation.

Place a receptacle that holds at least 20 liters (5.3 gal) under the drain plug.

Remove the drain plug (1). Allow all the oil to drain out and refit the plug.



Deliver the drain oil to environmentally correct handling.

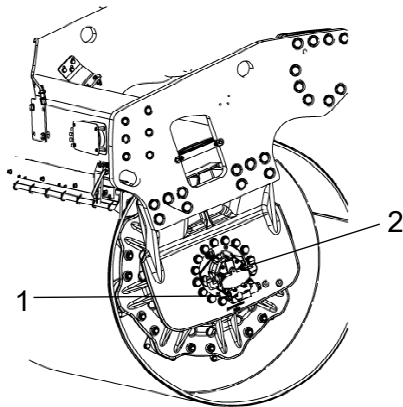
See under the heading 'Every 500 hours of operation' for filling oil.



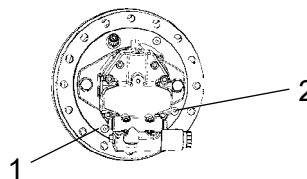
### Drum gear - Oil change

Place the roller on a level surface.

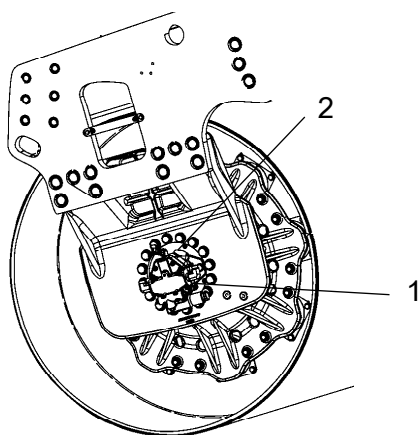
Wipe clean, unscrew the plugs (1, 2) and drain the oil into a suitable receptacle, capacity about 2 liters (0.5 gal.).



**Fig. Drum gear**  
**1. Drain plug**  
**2. Ventilating plug**



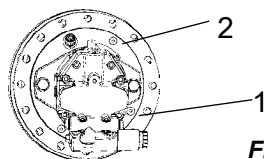
**Fig. Drum gear**



**Fig. Oil level check - drum gear**  
1. Level plug  
2. Filling plug

**Drum gear - Checking the oil level**

Move the machine until the inspection/filling holes are in position for filling.



**Fig. Drum gear**

Fill with the requisite volume of new oil. See technical specifications. Use transmission oil, see lubricant specifications.

Ensure that the oil level reaches up to the lower edge of the plug hole.

Clean and refit the plugs.



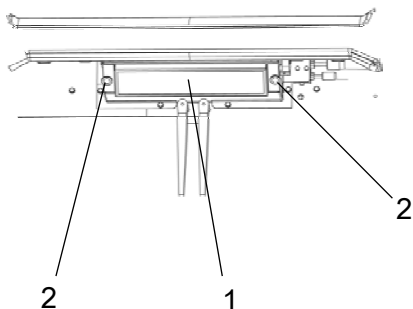
**Cab**  
**Fresh air filter - Replacing**

There is one fresh air filter (1), placed on the front of the cab.

Remove the protective cover.

Undo the screws (2) and remove the complete holder. Remove the filter insert and replace with a new filter.

The filter may need to be changed more often if the machine is operated in a dusty environment.



**Figure. Cab, front**  
1. Fresh air filter (x1)  
2. Screw (x2)



## Maintenance - 2000h



**Park the roller on a level surface. The engine must be switched off and the parking brake activated when checking or adjusting the roller, unless otherwise specified.**



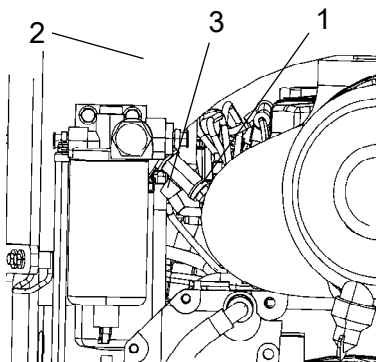
**Ensure that there is good ventilation (air extraction) if the engine is run indoors. Risk of carbon monoxide poisoning.**



### Hydraulic reservoir Fluid change



**Take care when draining the hydraulic fluid. Wear protective gloves and goggles.**



**Figure. Engine compartment under hydraulic tank (via left side)**

- 1. Oil drain**
- 2. Hydraulic tank**
- 3. Valve**

Open left engine compartment. The drain plug/valve is in the area under the hydraulic tank.

Place a receptacle that holds at least 50 liters (13.2 gal) under the engine compartment.

Make sure that the valve (3) is closed.

Unscrew the oil drain plug (1), and connect a drain hose out from the engine compartment.

Open the valve (3) and allow all the oil to run out. Reset by closing the valve and refitting the plug (1).



Deliver the drained fluid to environmentally correct handling.

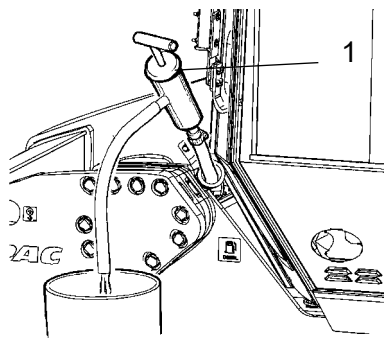
Fill with fresh hydraulic fluid. Refer to the lubricants specification for grade information.

Replace the hydraulic filter. See section "Maintenance - 1000 hours".

Start the engine and operate the hydraulic functions. Check the level in the reservoir and top off as required.



**Fuel tank  
- Cleaning**



**Fig. Fuel tank**  
1. Oil drain pump

It is easiest to clean the tank when it is almost empty.

A drain plug is placed under the left side of the front frame.

Alternatively drain the tank with a suitable pump, e.g. an oil drain pump, to bring up any bottom sediment.



Collect the fuel and sediment in a container and deliver to environmentally correct handling.



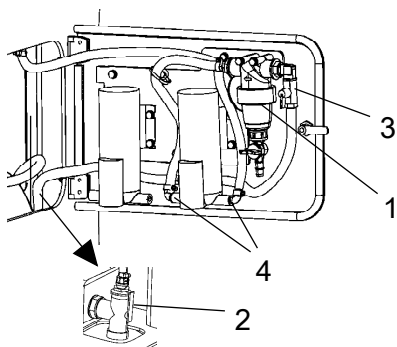
**Keep in mind fire risk when handling fuel.**



**Watering system  
- Draining**



Remember that there is a risk of freezing during the winter. Empty the tank, pump, filter and lines, or mix antifreeze in the water.



**Figure. Pump system**  
1. Filter housing  
2. Drain cock  
3. Stop cock  
4. Quick couplings

There is a drain cock (2) in the space for the pump system on the central water tank. This can be used to drain both the tank and parts of the pump system.

The water hoses are connected to the pump with quick couplings (4) to simplify draining and where appropriate replacement to a reserve pump (option).

The outlet hose from the central tank can be disconnected and the end placed in a container with antifreeze to run this through the pump/filter.



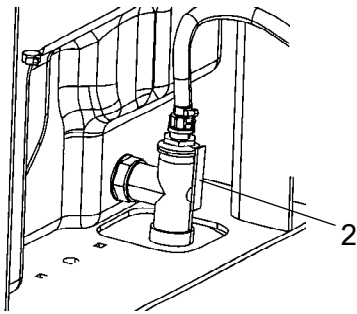
### Water tank - Cleaning

Clean the tank/tanks with water and a suitable detergent for plastic surfaces.

Close the drain cock (2), fill with water and check for leaks.



The water tanks are made of plastic (polyethylene) and are recyclable.



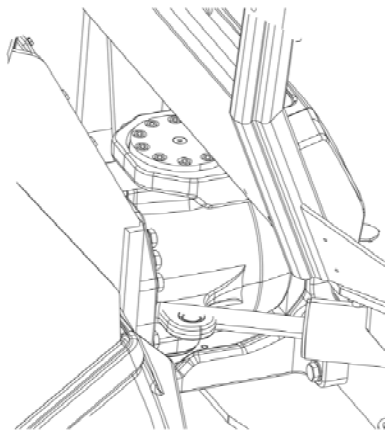
**Figure. Water tank**  
**2. Drain plug**

### Steering joint - Check

Inspect the steering joint to detect any damage or cracks.

Check and tighten any loose bolts.

Check also for any stiffness or play in the steering joint.



**Fig. Steering joint**



**Air conditioning (Optional)  
- Overhaul**

Regular inspection and maintenance is necessary to ensure satisfactory long-term operation.

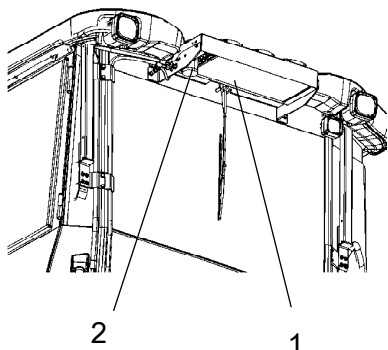
Clean all dust from the condenser element (1) using compressed air. Blow from above downwards.



The air jet can damage the element flanges if it is too powerful.



***Wear protective goggles when working with compressed air.***



**Figure. Cab**  
1. Condenser element  
2. Drying filter

Inspect the condenser element attachment.

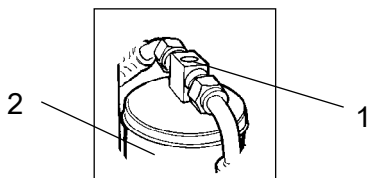
Check the system hoses for chafing. Make sure that drainage from the cooling unit is unobstructed so that condensation does not accumulate inside the unit.

**Air conditioning (Optional)  
Drying filter - Inspection**

With the unit in operation, check using the sight glass (1) that bubbles are not visible on the drying filter.



***Park the roller on a level surface, chock the wheels and depress the parking brake control.***



**Figure. Drying filter**  
1. Sight glass  
2. Filter holder

The filter is placed at the top of the rear part of the cab roof.

If bubbles are visible through the sight glass, this indicates that the refrigerant level is too low. Stop the unit to avoid risking damage. Fill up with refrigerant.



***The refrigerant circuit is only to be worked on by authorized companies.***

***DYNAPAC***

Part of the Atlas Copco Group

***DYNAPAC***

Part of the Atlas Copco Group