

DYNAPAC

Part of the Atlas Copco Group

OPERATION & MAINTENANCE

Paver finisher

F 161 W

Type 656

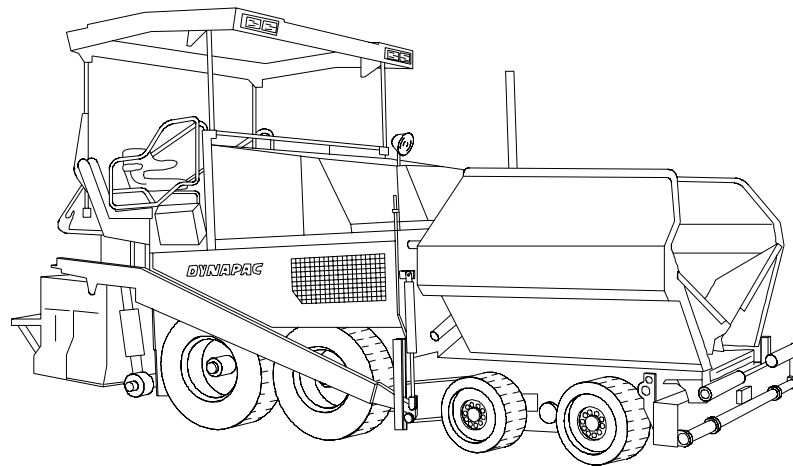

Keep this manual for future reference

Order number for this manual: D900981415

GB

03-0107

656

DYNAPAC

Part of the Atlas Copco Group

**VALUE QUALITY
THE ORIGINAL**

Your Authorized Dynapac Dealer:

Table of contents

V	Preface	1
1	General safety instructions	2
1.1	Acts, directives, accident prevention regulations	2
1.2	Warning instructions	2
1.3	Prohibitive signs	4
1.4	Protective gear	5
1.5	Environmental protection	6
1.6	Fire prevention	6
1.7	Further instructions	7
A	Correct use and application	1
B	Vehicle description	1
1	Application	1
2	Description of assemblies and functions	2
2.1	Vehicle	3
	Construction	3
3	Danger zones	7
4	Safety devices	8
4.1	Emergency stop button	8
4.2	Parking brake („Hand Brake“) (16)	8
4.3	Service brake („foot brake“) (17)	8
4.4	Steering	8
4.5	Horn	8
4.6	Ignition key / lights	8
4.7	Main switch (17)	9
4.8	Hopper transport safeguards (18)	9
4.9	Screed transport safeguards (19)	9
4.10	Latch for protective roof (20)	9
5	Technical data, standard configuration	11
5.1	Dimensions (all dimensions in mm)	11
5.2	Allowed angle of rise and slope	12
5.3	Allowed angle of driving up	12
5.4	Turning radius, turning circle	12
5.5	Weights (all weights in t)	13
5.6	Capacity data	14
5.7	Traction drive/chassis	15
5.8	Motor	15
5.9	Hydraulic system	15
5.10	Material compartment (hopper)	16
5.11	Material conveying	16
5.12	Material distribution	16
5.13	Screed lifting device	17
5.14	Electrical system	17
6	Location of instruction labels and identification plates	18
6.1	Identification label for the paver finisher (7)	20

7	EN standards	21
7.1	Continuous sound level	21
7.2	Operating conditions during measurement	21
7.3	Measuring point configuration	21
7.4	Vibration acting on the entire body	22
7.5	Vibrations acting on hands and arms	22
7.6	Electromagnetic compatibility (EMC)	22
C1.2	Transportation	1
1	Safety regulations for transportation	1
2	Transportation on low-bed trailers	2
2.1	Preparations	2
2.2	Drive onto the low-bed trailer	4
2.3	Secure the paver finisher in its position to the low-bed trailer:	5
2.4	After transportation	5
3	Transportation	6
3.1	Preparations	6
3.2	Traction drive	7
4	Loading by crane	9
5	Towing	10
6	Safely parking the vehicle	11
D1.0	Operation	1
1	Safety regulations	1
2	Operating elements	2
2.1	Operating panel	2
3	Remote control	24

D2.0	Operation	1
1	Operation of the input and display terminal	1
	Allocation of the keyboard of the display.	1
1.1	Working in the menu	2
	Menu structure of the setting and display options	3
	Main menu 00	4
	Display and function menu	4
	Menu 01 - Engine speed	5
	Submenu 101 - Setting the engine speed	5
	Menu 02 - Measuring value of drive engine	6
	Submenu 103 - Display of measuring value Drive engine	6
	Menu 03 - Trip meter and fuel gauge	7
	Submenu 301 - Road section, fuel consumption display/reset	7
	Menu 04 - Emergency function / stopping the screed and turning on the tamper	8
	Submenu 401 - Emergency functions adjustment	8
	Menu 05 - Layer thickness	9
	Submenu 501 - Preselection of layer thickness	9
	Submenu 502 - Setting the speed of auger	10
	Submenu 503 - Adjustment of the speed of conveyor	10
	Menu 06 - Screed charging	11
	Submenu 102 - Starting load setting	11
	Menu 07 - Screed type	12
	Submenu 701 - Setting the screed type	12
	Menu 08 - Service hour meter	13
	Menu 09 - Service	14
	Submenu 201 - Password prompt	14
	Menu 10 - Error memory	15
	Error message display:	15
	Error display	15
	Menu 11 - Error memory Computer of machine operation	16
	Error message display:	16
	Error display	16
	Menu 12 - Program version	17
	Menu 13 - Terminal settings	18
	Submenu 104 - Terminal settings	18
1.2	Further messages on the display	19
2	Terminal error messages	20
2.1	Instructions related to error messages	26
2.2	Fault codes of the traction engine.	27
2.3	Error messages	29
2.4	FMI-codes	34
2.5	Special functions	35
	Emergency operation program for the case of keyboard failure	35
	Reversible conveyor	36

D3.2	Operation	1
1	Operating elements on the paver finisher	1
	Engine hood (70)	1
	Batteries (71)	1
	Battery main switch (72)	2
	Transport safeguards for the hopper (73)	3
	Mechanical screed transport safeguard (to the left and the right beneath the driver's seat) (74)	4
	Seat lock (behind the driver's seat) (75)	4
	Service brake („foot brake“) (76)	5
	Parking brake („Hand Brake“) (77)	5
	Change lever of the two-stage transmission (78)	5
	Change lever of the differential lock (79)	6
	Separator fluid spraying system (80) (o)	7
	On / off switch for additional headlight in the roof (85):	8
	On / off switch for fuel tank filler pump (85a)	8
	On / off switch special lighting (85b)	8
	On / Off switch Exhaust of asphalt vapours (85c)	8
	On/Off switch of work headlights (85d):	9
	On/Off switch of flasher (85e):	9
	230 V On / Off switch Connection sockets (85f)	9
	Locking of the collapsible roof (LH and RH on the roofs console) (86) .	9
	Hydraulic folding roof (87) (o)	10
	Electric setting of the transportation volume of the conveyor (o) (88) .	11
	Conveyor limit switches (89):	11
	Ultrasonic auger limit switches (90) (left and right)	12
	Sockets for working lights (left and right) (92)	12
	Pressure control valve for screed charging/relieving (93) (o)	13
	Pressure control valve for screed stop with pretensioning (93a) (o)	13
	Manometer for screed charging/relieving and screed stop with pretensioning (93b)	13
	Front wheel drive pressure regulating valve (94) (o)	14
	Pressure gauge of the front wheel drive (94a) (o)	14
	Central lubrication unit (o) (100)	15
	Particle filter - control light (102) (o)	16
	Front and side window (o) (103)	17
	Adjustment of screed eccentric (o) (104)	17

D4.2	Operation	1
1	Operation	1
1.1	Preparation of operation	1
	Required devices and aids	1
	Before starting work (in the morning or when starting paving)	1
	Checklist for the machine operator	2
1.2	Starting the paver finisher	4
	Before starting the paver finisher	4
	„Normal” starting	4
	External starting (starting aid)	5
	After starting	6
	Indicator lamps	7
	Oil pressure indicator lamp for the traction drive (46)	7
	Battery charge indicator (49)	8
1.3	Operation in case of transportation	9
	Lifting and securing the screed	9
	Driving and stopping the paver finisher	10
	Switching off and securing the paver finisher	10
1.4	Preparations for paving	11
	Separating agent	11
	Screed heater	11
	Direction marks	11
	Loading/distributing material	12
1.5	Starting for paving	14
1.6	Checks during paving	16
	Paver finisher function	16
	Quality of the layer	16
1.7	Paving with screed stop and screed charging/relieving	16
	General	16
	Screed charging/relieving	17
	Screed stop with prestressing	18
	Screed stop with prestressing	18
	Adjusting the pressure (o)	19
	For screed charging/relieving:	19
1.8	Interrupting/terminating operation	20
	During breaks: (e.g. the material supply truck is late)	20
	During extended interruptions (e.g. lunch break)	20
	When work is finished	20
2	Special functions	23
2.1	Electro-hydraulic differential lock	23
2.2	Electro-hydraulic selection of gears	24
2.3	Problems during paving	25
2.4	Malfunctions on the paver finisher or screed	27

E01	Set-up and modification	1
1	Special notes on safety	1
2	Auger	2
2.1	Height adjustment	2
2.2	Auger crossbeam installed in a fixed position	2
2.3	Mechanical adjustment with ratchet (optional)	3
2.4	In case of hydraulic adjustment (option)	3
2.5	Auger extension, auger type I	5
2.6	Mounting extension parts	6
2.7	Mounting support tube extensions	7
2.8	Installing tunnel plates	8
2.9	Installing additional braces	9
2.10	Auger mounting chart for \varnothing 310 mm auger	10
2.11	Auger mounting chart for \varnothing 380 mm auger	11
3	Auger extension, auger type II	12
3.1	Mounting extension parts	13
3.2	Auger modification plan.	15
4	Screed	17
5	Electrical connections	17
5.1	Remote controls	17
5.2	Grade control	17
5.3	Auger limit switches	17
5.4	Working lights	17
F1.0	Maintenance	1
1	Notes regarding safety	1
F2.6	Maintenance overview	1
1	Maintenance review	1
F3.1	Maintenance - Conveyor	1
1	Maintenance - Conveyor	1
1.1	Maintenance intervals	2
1.2	Points of maintenance	3
	Chain tightness of the conveyor (1)	3
	The drive of conveyor (to the left/to the right) (2)	4
F4.2	Maintenance - Auger	1
1	Maintenance - Auger sub-unit I	1
1.1	Maintenance intervals	2
1.2	Points of maintenance	3
	Auger - outer bearing (1)	3
	Auger middle bearing (2)	3
	Auger - drive gear neck bearing (3)	4
	Auger bevel gear (on the RH and LH sides) (4)	5

F5.1	Maintenance - Engine	1
1	Maintenance - engine sub-unit	1
1.1	Maintenance intervals	2
1.2	Points of maintenance	4
	Engine fuel tank (1)	4
	Engine lube-oil system (2)	5
	Engine fuel system (3)	7
	Engine air filter (4)	9
	Coolant system of the engine (5)	10
	Engine drive belt (6)	10
	Engine exhaust system (7)	11
F6.1	Maintenance - hydraulic system	1
1	Maintenance - hydraulic system	1
1.1	Maintenance intervals	2
1.2	Points of maintenance	3
	Hydraulic oil tank (1)	3
	Suction/return flow hydraulic filter (2)	4
	High pressure filter (3)	5
	Pump distribution gear (4)	6
	Hydraulic hoses (5)	7
F7.3	Maintenance - travel drive, steering	1
1	Maintenance - travel drive, steering	1
1.1	Maintenance intervals	2
1.2	Points of maintenance	3
	Chain tightness (drive) - (1)	3
	Drive shaft (2)	4
	Air pressure (driving wheels) (3)	5
	Places of lubrication (4)	6
	Steering	6

F8.2	Maintenance - Electronic System	1
1	Maintenance - Electronic System	1
1.1	Maintenance intervals	2
1.2	Points of maintenance	5
	Batteries (1)	5
	Generator (2)	6
	Adjustment of belt tightness	8
	Replacement of belt	9
	Checking / adjusting belt tension:	10
	If necessary, adjust the belt tension:	10
	Electric fuses (3)	11
	Type of machine: Conventional elec-tronics	11
	Terminal box	11
	Fuses in terminal box (B)	12
	Fuses on operating panel	13
	Relays in operating panel	14
	Type of machine: PLC electronics	15
	Terminal box	15
	Fuses in terminal box	16
	Relays in terminal box (C)	18
	Fuses on operating panel	19
F9.0	Maintenance - Points of lubrication	1
1	Maintenance- Points of lubrication	1
1.1	Maintenance intervals	2
1.2	Points of maintenance	3
	Central lubrication (1)	3
	Bearings (2)	7
F10.0	Checks, decommissioning	1
1	Tests, check-up, cleaning, stopping	1
1.1	Maintenance intervals	2
2	General observation	3
3	Checks by a specialist	3
4	Cleaning	4
5	Conservation of paver finisher	5
5.1	Downtime up to 6 months	5
5.2	Downtime between 6 months and 1 year.	5
5.3	Re-commissioning:	5
F11.3	Lubricants and operating substances	1
1	Lubricants and operating substances	1
1.1	Hydraulic oils	2
1.2	Filling volumes	3
2	Notes on changing over from mineral oil to synthetic oil / synthetic oil to mineral oil	7
2.1	Track planetary gear	7

V Preface

Safe operation of the machine requires specific knowledge that is imparted by the present operating instructions. The information is provided in a concise, clearly structured form. The individual chapters are arranged in alphabetical order and every chapter starts with page 1. The individual pages are identified by the chapter letter and the page number.

Example: Page B 2 is the second page of chapter B.

These operating instructions cover various machine options. Make sure that during operation and maintenance work the description appropriate to the machine option is used.

Safety instructions and important notes are identified by the following pictograms:

- f Precedes safety instructions that must be observed in order to prevent danger to personnel.
- m Precedes notes that must be observed to prevent damage to equipment.
- A Precedes general notes and explanations.
- t Used to indicate standard equipment.
- o Used to indicate optional equipment.

In the interest of continued development, the manufacturer reserves the right to make changes to the machine (which will not, however, change the essential features of the type of machine described) without updating the present operating instructions at the same time.

Dynapac GmbH
Wardenburg

Ammerländer Strasse 93
D-26203 Wardenburg / Germany
Telephone: +49 / (0)4407 / 972-0
Fax: +49 / (0)4407 / 972-228
www.dynapac.com

1 General safety instructions

1.1 Acts, directives, accident prevention regulations

A The locally applicable acts, directives and accident prevention regulations shall be observed, even if the attention is not specifically directed to these.
The operator himself shall be responsible for the observation and performance of the related regulations and actions!

A The following alerts, prohibitions and instructions refer to the risks to which people, machinery and environment are exposed.

A Ignoring these instructions, bans and commands may lead to fatal injuries!

A Furthermore, the Dynapac publication "Directives for the correct and specified application of pavers" shall also be observed.

1.2 Warning instructions

Warning pointing to hazardous place or danger!
Not observing the warning instructions may lead to injuries of life and limb!



Warning: risk of pulling in!

m In this area / with these equipment as a result of rotating or transportation parts, there is a risk of pulling in!
Perform each operation only with equipment switched off!



Attention: electric voltage!

m All maintenance and repair work on the screed's electrical system must always be carried out by an electrician!

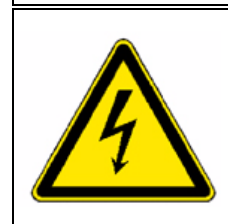

Attention: suspended load!

m Never stand under suspended load!



Warning: risk of squeezing!

m Risk of squeezing arises due to the operation of certain parts, use of some functions and the movement of the machine.
Always make sure that no one stays in the areas exposed to risk!



Attention: risk of hand injury!



Attention: hot surfaces or hot liquids!



Warning, risk of falling off!



Attention: hazardous batteries!



Attention: materials harmful to health and irritating substances!



Attention: flammable materials!



Attention: gas bottles!



1.3 Prohibitive signs

It is prohibited to open / step on / reach into / perform / adjust during operation or when the traction engine is running!



Do not start the engine/drive!

Maintenance and repair works can be carried out only with the Diesel engine turned off!



Do not sprinkle with water!



Do not extinguish with water!



Do-it-yourself maintenance is prohibited!

Maintenance can be performed by skilled professionals only!



A Contact the Dynapac service!

Danger of fire: do not use open flame and no smoking!



Do not turn on!



1.4 Protective gear

- A The applicable local regulations may define the use of different protective gear!
Observe these specifications!

Protect your eyes with goggles!



Wear appropriate head protection!



Protect your hearing with appropriate ear muffs!



Protect your feet with safety footwear!



Always wear tight, conforming working coveralls!
Wear visibility vest for good visibility!



In case of polluted air, wear respiratory mask!



1.5 Environmental protection

A The locally applicable acts, directives and waste disposal regulations shall be observed, even if the attention is not specifically directed to these.
During cleaning, maintenance and repair operation the materials polluting water e.g.:

- lubricants (oils, grease)
- hydraulic oil
- gas oil
- coolant
- detergents

may not enter the soil or the sewer system!

These materials shall be collected, stored, transported in the correct containers until professional disposal!



Material harmful for the environment!



1.6 Fire prevention

A The applicable local regulations may specify the mounting of appropriate fire extinguishers!
Observe these specifications!

Fire fighting device
(optional equipment)



1.7 Further instructions

m Observe the manufacturer's and other instructions!

A e.g. the maintenance instructions of the engine manufacturer

m Description / figure in case of an electrically heated design!

m Description / figure in case of an electrically heated design!

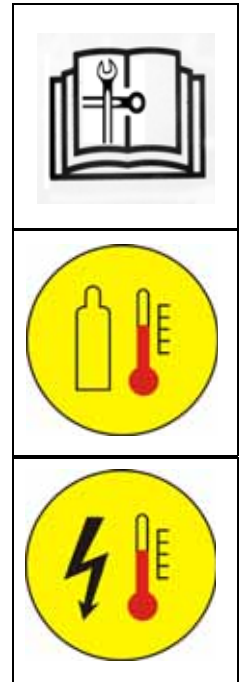

A Correct use and application

- A The “Guidelines for the Correct Use and Application of Paver finishers” compiled by Dynapac are included in the scope of delivery for the present machine. The guidelines are part of the present operating instructions and must always be heeded. National regulations are fully applicable.

The road construction machine described in the present operating instructions is a paver finisher that is suited for laying mixed materials, roll-down concrete or lean-mixed concrete, track-laying ballast and unbound mineral aggregates for foundations for paving.

This machine shall be used, operated and maintained for the purpose of the intended work as included in the operation manual. Any other use is regarded as improper use and can cause injury to persons or damage to the paver finisher or other equipment or property.

Any use going beyond the range of applications described above is regarded as improper use and is expressly forbidden! Especially in those cases where the paver finisher is to be operated on inclines or where it is to be used for special purposes (construction of dumps, dams), it is absolutely necessary to contact the manufacturer.

Duties of the user: A “user” within the meaning of the present operating instructions is defined as any natural or legal person who either uses the paver finisher himself, or on whose behalf it is used. In special cases (e.g. leasing or renting), the user is considered the person who, in accordance with existing contractual agreements between the owner and the user of the paver finisher, is charged with the observation of the operating duties.

The user must ensure that the paver finisher is only used in the stipulated manner and that all danger to life and limb of the operator, or third parties, is avoided. In addition to this, it must be ensured that the relevant accident prevention regulations and other safety-related provisions as well as the operating, servicing and maintenance guidelines are observed. The user must also ensure that all persons operating the equipment have read and understood the present operating instructions.

Mounting of attachments: The paver finisher must only be operated in conjunction with screeds that have been approved by the manufacturer. Mounting or installation of any attachments that will interfere with or supplement the functions of the paver finisher is permitted only after written approval by the manufacturer has been obtained. If necessary, the approval of local authorities has to be obtained.

Any approval obtained from local authorities does not, however, make the approval by the manufacturer unnecessary.

B Vehicle description

1 Application

The DYNAPAC F 161 W / F 161-6 W / F161-8 W road construction machine is a rubber tyre type paver, which can be applied for laying mixed materials, roll-down concrete or lean-mixed concrete, track-laying ballast and unbound mineral aggregates for foundations for paving.

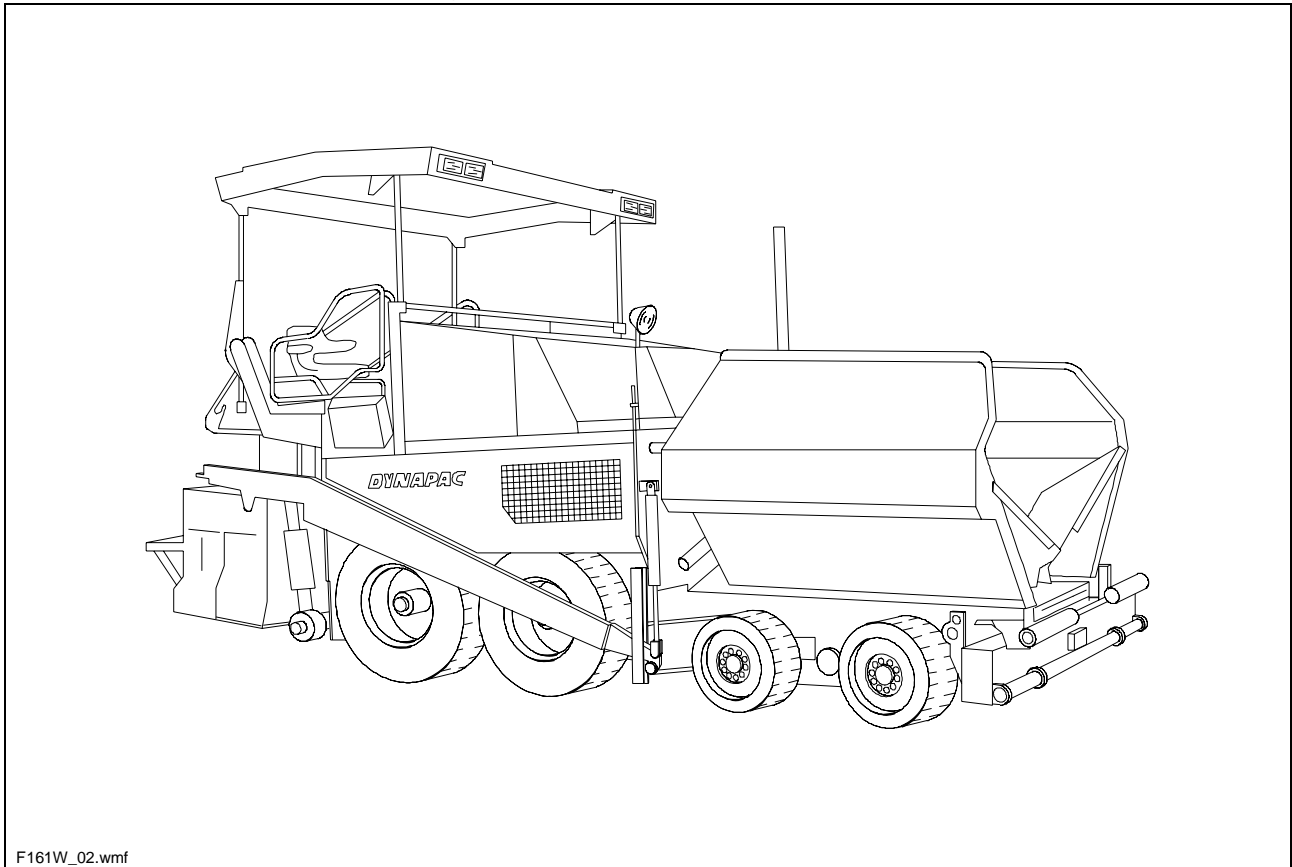

2 Description of assemblies and functions

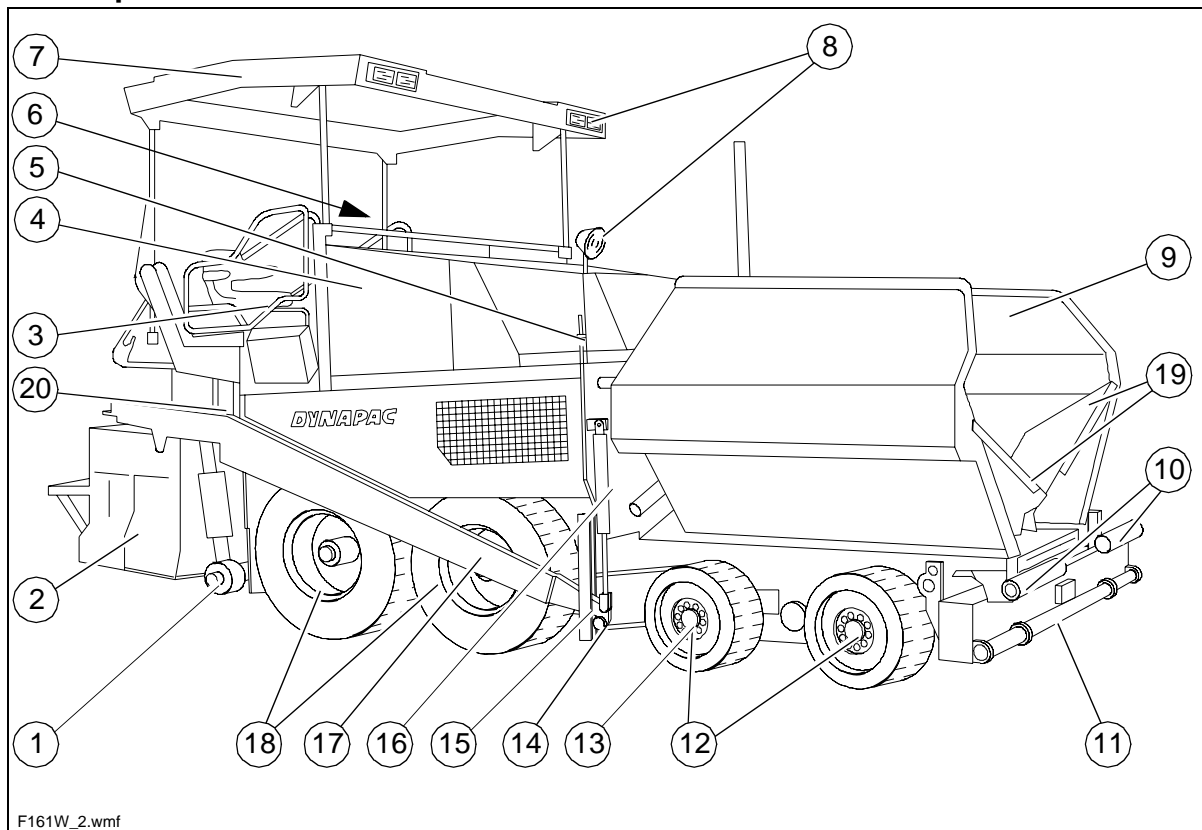

Item		Designation
1	t	Auger
2	t	Screed
3	t	Operator's platform
4	t	Storage space for toolboxes on the left/right sides
5	t	Paving thickness indicator
6	t	Operating panel (can be moved to either side)
7	o	Protective roof
8	o	Working lights
9	t	Material compartment (hopper)
10	t	Truck push rollers
11	t	Tube for sensor rod (direction indicator) and holder for levelling shoe
12	t	Front tandem shaft (with the F 161-8 W drive)
13	t	Shaft with front wheel drive (F 161-6 W)
14	t	Traction roller
15	t	Traction arm rail
16	t	Levelling cylinder for paving thickness
17	t	Arm
18	t	Rear wheels
19	o	Hydraulic hopper lid
20	o	Exhaust of asphalt vapours

t = Standard equipment

o = Optional equipment

2.1 Vehicle

Construction

The paver finisher has a welded steel frame on which the individual components are mounted.

The large drive wheels together with the front tandem shaft jointly compensate the irregularities of the soil and as a result of the suspension of the screed they guarantee a particularly high paving precision.

The continuously adjustable hydrostatic traction drive allows the speed of the paver finisher to be matched to all work conditions.

The operation of the road construction equipment is considerably facilitated by the automatic mixer device, the independent drives and the transparent operating components and controls.

The following extra equipment (option) is available:

- Supplementary front-wheel drive (F161-6W / F161-8W) with anti-spin
- Automatic levelling/slope control system
- Ultrasonic sensors for material transport (controller)
- Additional cut-off shoe
- Larger working widths
- Automatic central lubrication system for the paver finisher and/or the screed
- Protective roof
- Further equipment and upgrade options on request

Engine: The paver finisher is driven by a water cooled Diesel engine. For further details see the technical data and the engine's instruction manual.

The particle filter (○) cleans the exhaust gas from the soot particles produced, reduces the generation of harmful carbon-monoxide and carbon-dioxide gases, therefore, it operates as a catalyser to minimize the load on the environment and health. A control light indicates the necessity of maintenance operations.

Running gear: The front axle was designed as a tandem swinging axle. As the wheels are not mounted on non-uniform lifting axles, the second front wheel is subject to a heavier load on the shorter lifting arm.

As a result of this solution the steering possibility and the load capacity are improved, especially on soft ground. Tyres mounted with flexible solid tyres on the front wheels and large-size, tubeless, air filled tyres on the rear wheels (water filled tyres - ○).

In case of complementary (F 161-6 W / F161-8 W) front wheel drive the second front axle or both front axles can be engaged as additional drive axles.

Hydraulic system: The diesel engine drives the hydraulic pumps for all main drives of the paver finisher via the attached distribution gear and its auxiliary drive shafts.

Traction drive: The continuously adjustable traction drive pumps are connected to the traction motors by means of high pressure hydraulic hoses. The hydromotor drives the rear wheels through two-stage transmission gear and roller chains. The two-stage transmission has installed differential gear and differential lock.

Steering system/operator's platform: The fully hydraulic Danfoss-Orbitrol steering ensures easy maneuverability. The operating panel can be secured in a position at the left-hand or the right-hand side of the paver finisher by means of a latch accessible from above.

Push roller cross bar: The push rollers for material trucks are fastened to a cross bar that is pivoted at its center. This cross bar allows to compensate for different distances to the rear wheels of material trucks. The paver finisher thus deviates less from its course and paving in curves is made easier.

Material compartment (hopper): The hopper inlet is equipped with a conveyor system that empties the hopper and transfers the material to the auger. The hopper can hold about 12.5 t. To facilitate emptying and to improve material transport, each of the lateral covers of the hopper can be hydraulically moved (option). The hydraulic front hopper lids (○) ensure that no material remains at the front of the feeding hoppers.

Material transfer: The paver finisher is equipped with two conveyors driven separately that transfer the material from the hopper to the augers. By scanning the filling height during the paving procedure, the transfer amount or speed is regulated fully automatically.

Augers: The augers are driven and actuated independently from the conveyors. The left-hand and the right hand half of the auger can be controlled separately. The drive system is fully hydraulic.

The conveying direction can be changed towards the center or towards the outside. This ensures that there is always a sufficient supply with material even if an excessive amount of material is required at one side. The auger speed is continuously controlled by sensors that monitor the material flow.

Height adjustment and extension of augers: Height adjustment and extension of augers ensure optimum adaptation to a wide range of paving thicknesses and widths.

The basic configuration allows the height to be adjusted by attaching chains to the side arms and by actuating the hydraulic screed lifting device.

When using ratchets for height adjustment (option), barrel nuts at the guide supports in the rear wall are used to adjust the height.

Another variant allows the height to be regulated at the control panel by means of hydraulic cylinders (option).

Auger segments of different lengths can be attached to easily adapt to the different paving widths.

Automatic levelling/slope control system: The slope control system (option) allows the regulation of the traction point either on the LH or RH sides, by maintaining a difference defined against the opposite side.

To determine the actual value, the two traction arms are linked with a slope control rod.

The slope control system always operates in conjunction with the screed height adjustment of the opposite side.

By adjusting the height of the traction point of the arm (traction roller), the paving height of the material or the laying height of the screed can be controlled.

Actuation occurs electro-hydraulically on both sides and can be controlled manually by means of toggle switches or automatically (by means of an electronic grade control system).

The screed lifting system: The screed can be lifted to transport height using the screed lifting system. Lifting occurs electro-hydraulically on both sides by actuating the hydraulic cylinders on the arms and is controlled by means of toggle switches on the operating panel.

Automatic screed stop and screed charging/relieving device: The automatic screed stop prevents the screed marks caused by a stopped screed. When the paver finisher stops (during a truck change), the control valves set to the floating position are shut and locked, thus preventing the screed from sinking during the stop.

The screed relieving device puts a higher load on the chassis, thus increasing the traction.

Activating the screed charging device can improve the compacting result under certain conditions.

Exhaust of asphalt vapours (○): The asphalt vapours are extracted by a hydraulically driven exhaust head mounted in the material tunnel or over the auger. The vapours collected are discharged together with the exhaust fumes of the internal combustion engine.

Central lubrication unit (○): The central lubrication pump fitted with a large lubricant tank supplies grease to the various lubrication circuits through various flow dividers. They supply lubricant to the service-sensitive points of lubrication (e.g. bearings) by adjustable intervals.

3 Danger zones

- m In these areas of the machine there is a danger of pulling in or crushing due to the rotating, transporting or moving parts!

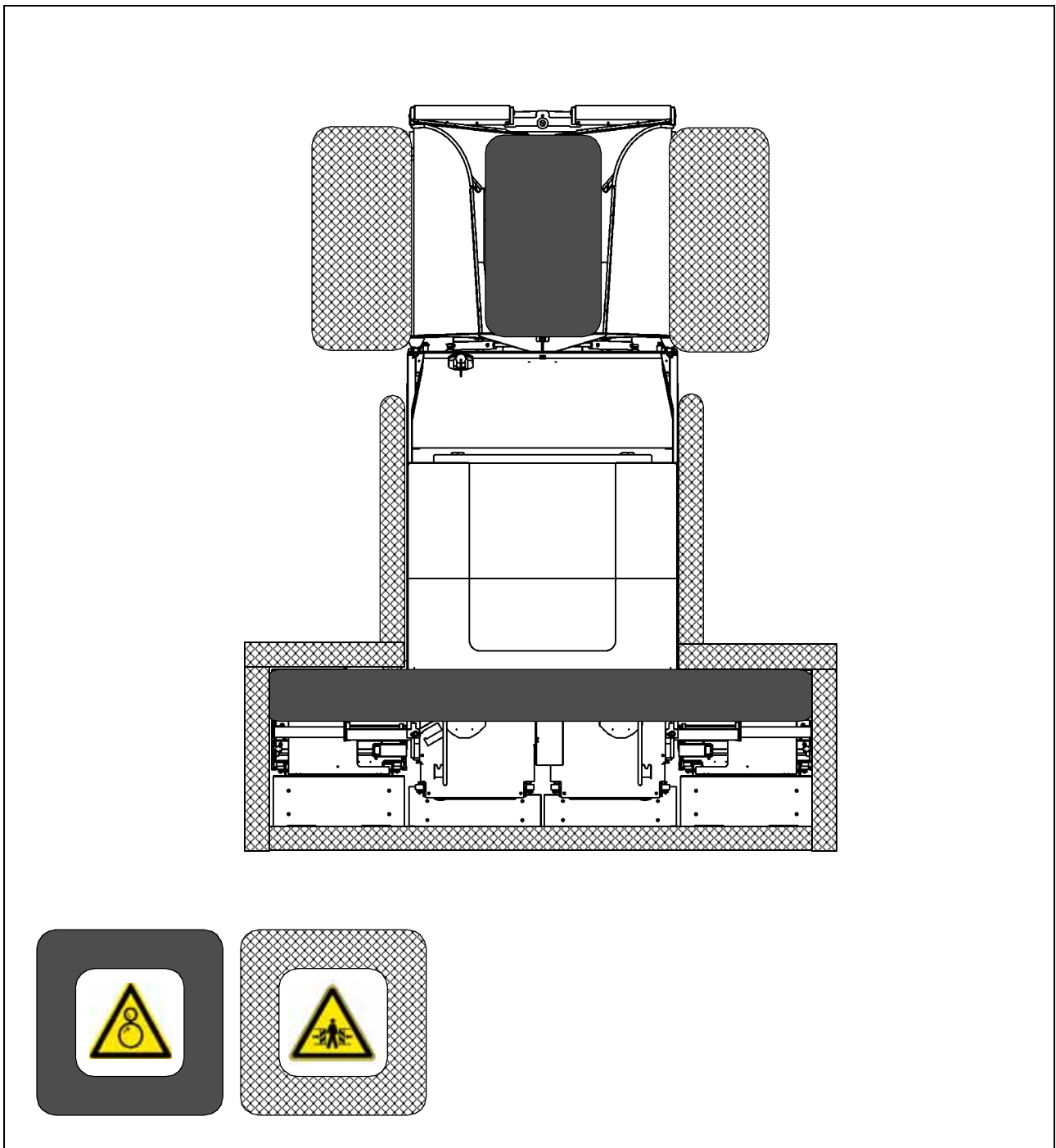

4 Safety devices

Safe operation is only possible when all operating and control elements are functioning correctly and when all safety devices are in position.

A Check the function of these devices at regular intervals.
(see chapter D, section 2.1).

4.1 Emergency stop button

- on the operating panel
- on the two remote control units (option)

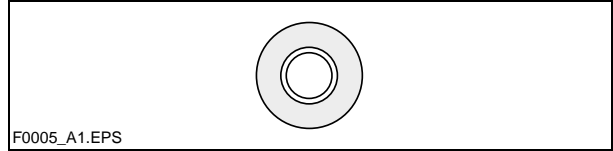

m Pressing the emergency stop button switches off the engine, the drives and the steering system. Corrective measures that might be necessary (anti-collision maneuvers, lifting the screed, etc.) are not possible in this case! Danger!

4.2 Parking brake („Hand Brake“) (16)

4.3 Service brake („foot brake“) (17)

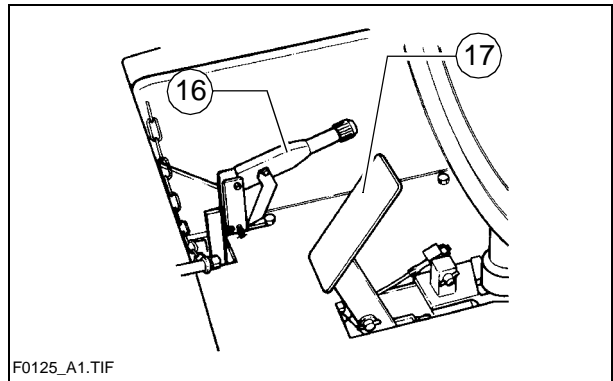

4.4 Steering

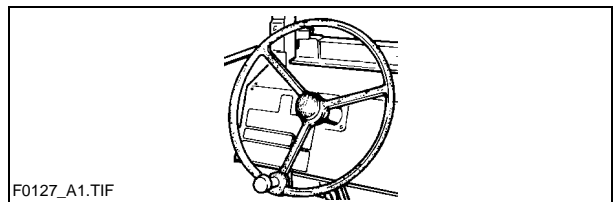

4.5 Horn

- on the operating panel
- on the two remote control units (option)

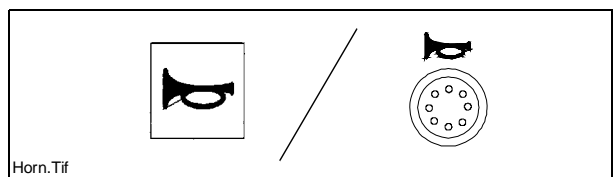

4.6 Ignition key / lights

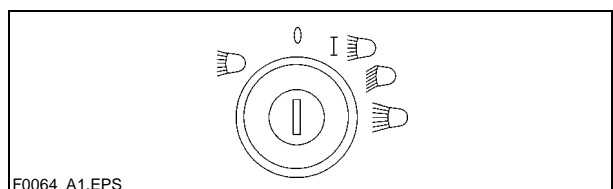

4.7 Main switch (17)

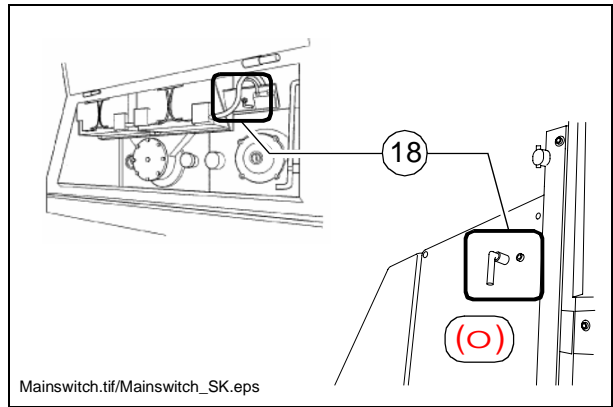

4.8 Hopper transport safeguards (18)

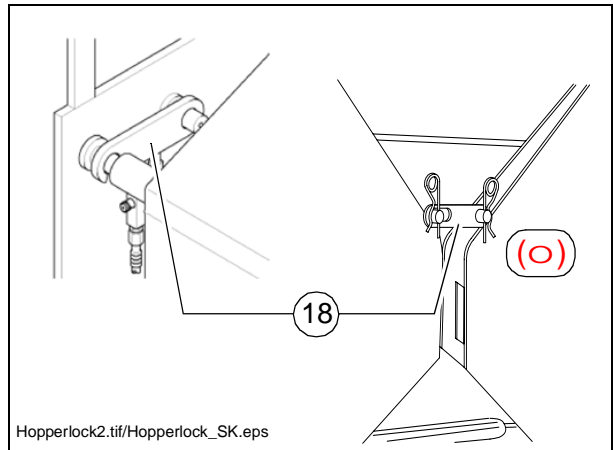

4.9 Screed transport safeguards (19)

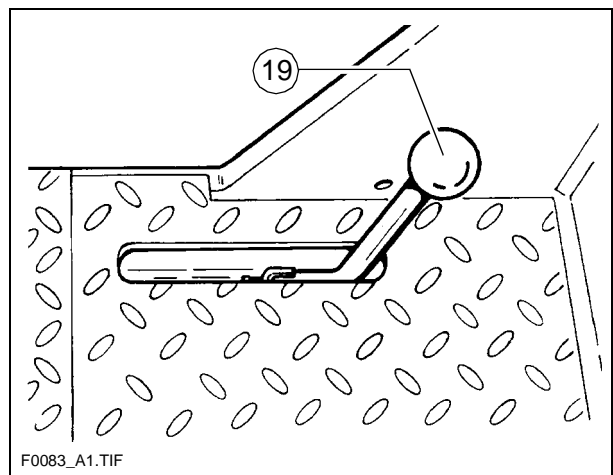

4.10 Latch for protective roof (20)

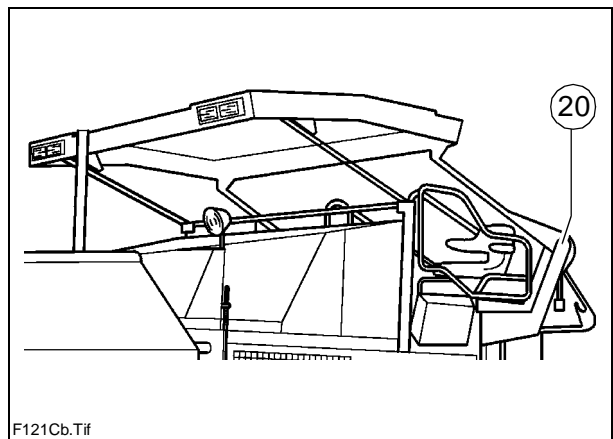

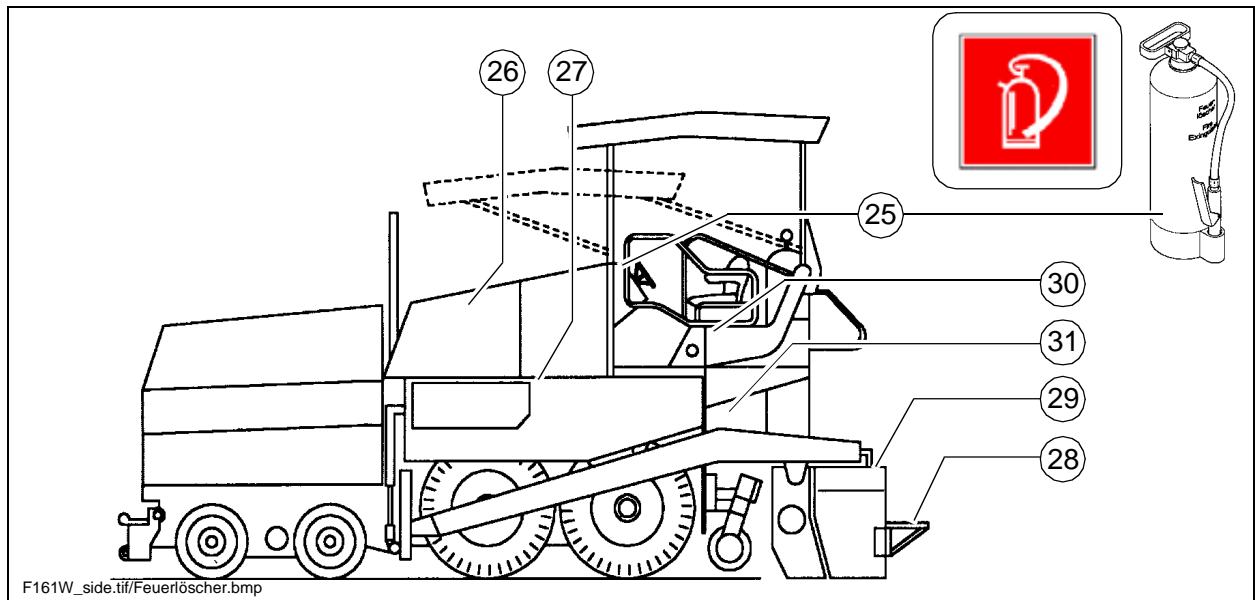

F161W_side.tif/Feuerlöscher.bmp

Item	Designation
25	Fire fighting device
26	Engine hood
27	Lateral flaps
28	Walkway
29	Screed coverings
30	Hazard warning lights of the screed
31	Auger covers

Accessories:

- Wedges
- Warning triangle
- First-aid kit

5 Technical data, standard configuration

5.1 Dimensions (all dimensions in mm)

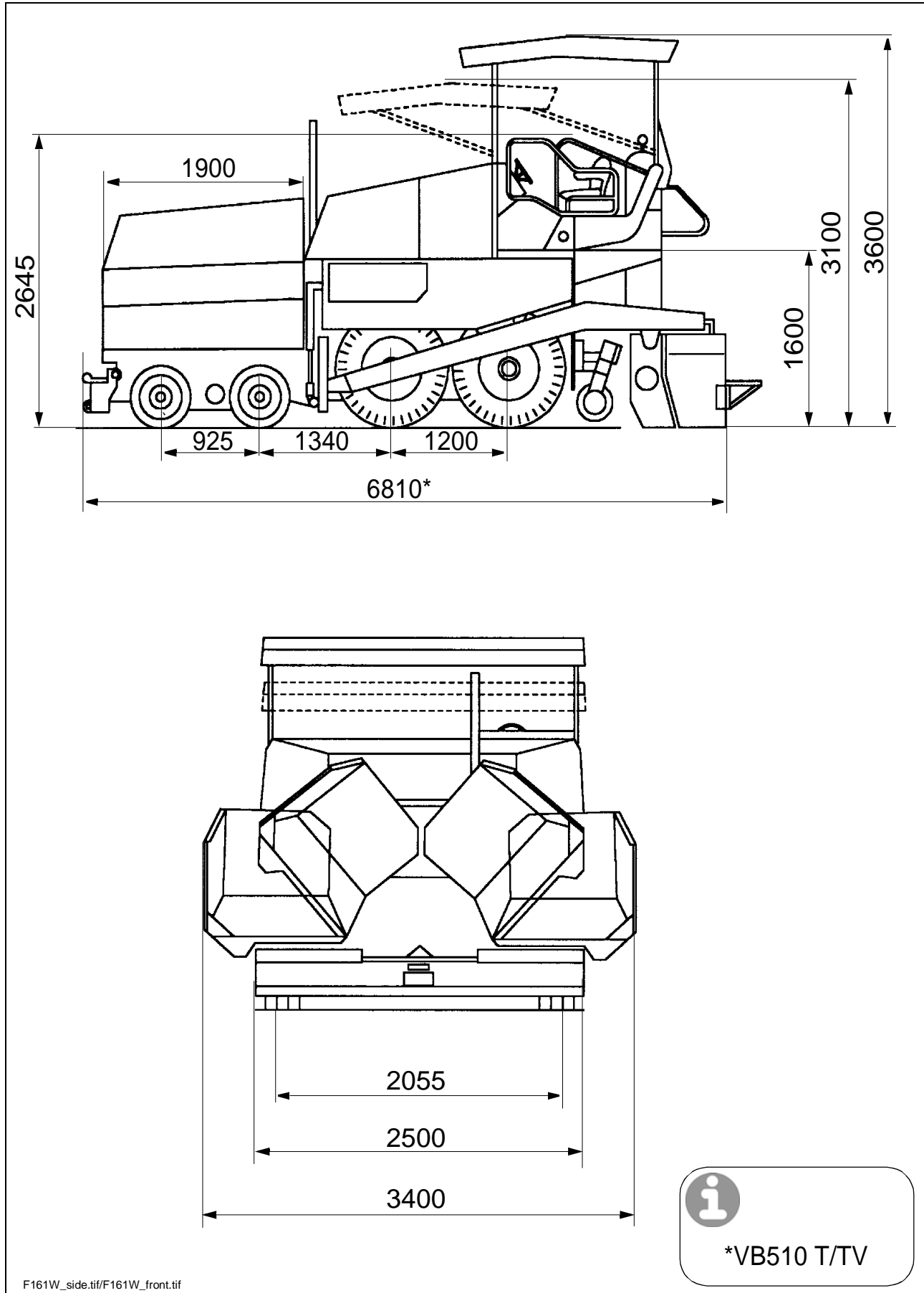

B_F161W_01_GB.fm 11-22 01-01.07

A For the technical data of the screed, see the operating instructions of the screed.

5.2 Allowed angle of rise and slope

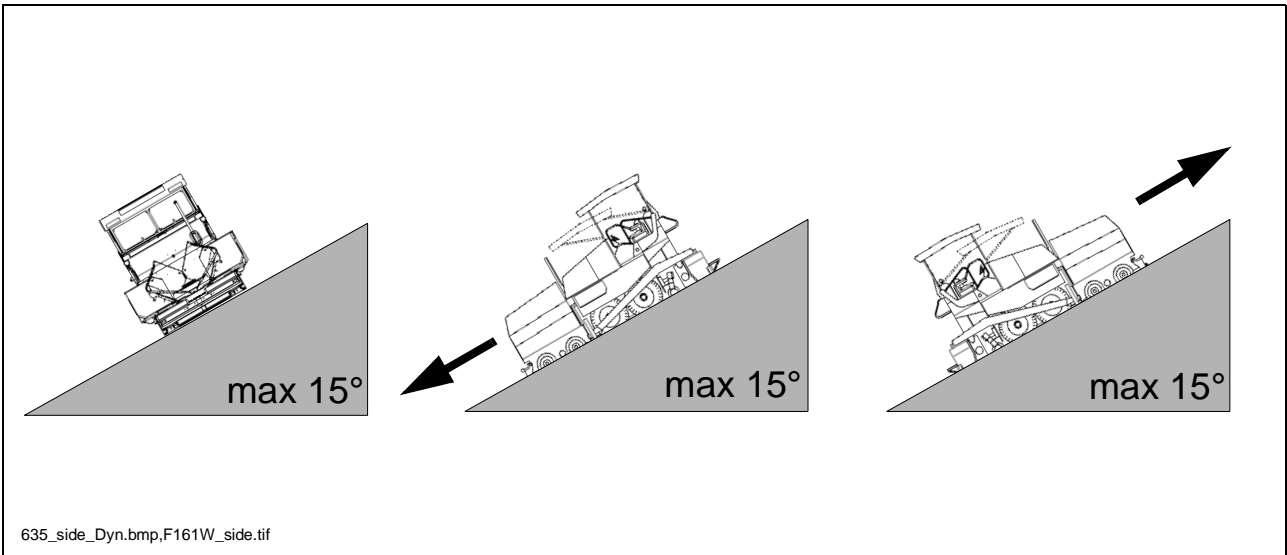

- A** Before operating your machine in an inclined position (gradient, slope, lateral inclination) which is above the specified limit value, please, consult with the customer service for your machine!

5.3 Allowed angle of driving up

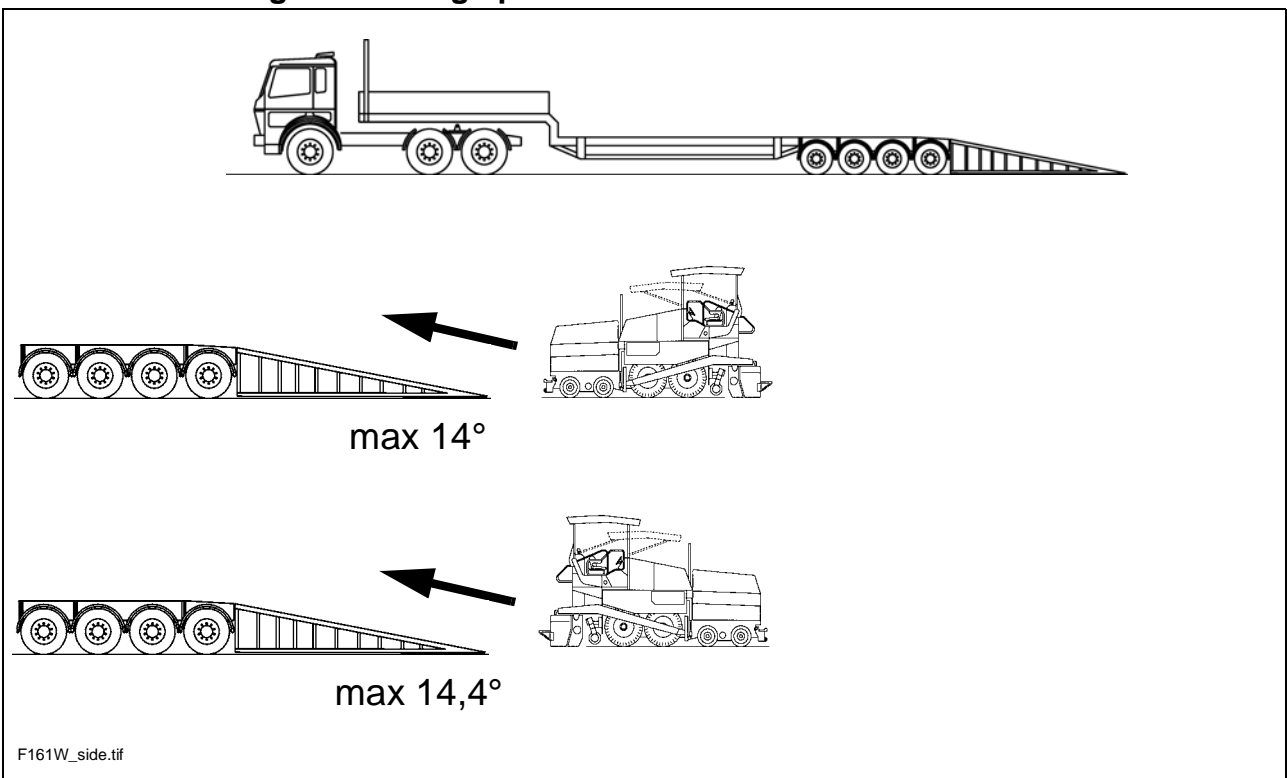

5.4 Turning radius, turning circle

Internal turning radius	4,45 m
Turning circle	15,30 m

5.5 Weights (all weights in t)

Type	F 161W
Paver finisher without screed	about 14,6
Paver finisher with screed: - VB 510T/TV	about 18,00
Including mounted accessories for max. paving width plus max.	about 1,3
With filled hopper additionally max.	about 12,5
Allowed total mass for transportation (without load)	about 18,00
max. front axle load for transportation	about 7,00
max. rear axle load for transportation	about 14,00

- A For the weights of the screed and the screed attachments, see the operating instructions for the screed.

5.6 Capacity data

Screed used	Basic width (without cut-off shoes)	minimum paving width (with cut-off shoe)	continuously hydraulically adjustable up to	Maximum paving widths (with attachments)	
VB 510 T/TV (E)	2,55	2,00	5,10	8,10	m
VB 510 T/TV (E) Plus	2,55	2,00	5,10	*	m
VB 600 T/TV (E)	3,00	2,45	6,00	*	m
VB 600 T/TV (E) Plus	3,00	2,45	6,00	*	m

*The maximum working width depends on the paving conditions!

Travelling speed	0 - 16,5	km/h
Working speed	0 - 26,7	m/min
Layer thickness	0 - 300	mm
Max. grain size	40	mm
Theoretical paving performance	650	t/h

5.7 Traction drive/chassis

Drive	Continuously variable hydrostatic drive, with pump and engine
Transmission	Through two-stage transmission with differential gear and differential lock
Speeds	(see above)
Drive wheels	4 x 13.00 R-22.5 (air filled tyres) (water filled tyres ○)
Steering wheels	4 x 560 / 390 - 300 (elastic solid rubber tyres)
Front wheel drive F 161-6 W / F161-8 W (○)	2 / 4 wheel hub hydro-motor, freely selected, variable drive performance, Anti-spin control (○)
Brakes	Travel drive brake, 2 hydr. disc brakes 1 mech. parking brake

5.8 Motor

Make/type	Deutz TCD 2013 L04 2V
Model	4-cylinder (water cooled) Diesel engine
Performance	116 KW / 158 HP (at 2100 rpm)
Volume of fuel tank	(see chapter F)

5.9 Hydraulic system

Pressure build-up	Hydro-pumps driven by transmission gear (directly connected to the engine)
Pressure distribution	Hydraulic circuits for: <ul style="list-style-type: none"> - Machine drive - Material conveying and distribution - Screed drives for tamper / vibration (option) - Cylinder actuators for steering, hopper, levelling, screed lifting, extending/retracting screed parts, auger lift (option)
Hydraulic oil reservoir - volume	(see chapter F)

5.10 Material compartment (hopper)

Volume	about 5,7 m ³ = about 12,5 t
Minimum inlet height, center	475 mm
Minimum inlet height, outside	595 mm

5.11 Material conveying

Conveyors	Left and right side separately controllable
Drive	Hydrostatic, continuously controllable
Conveying volume controller	Fully automatic via configurable switching points

5.12 Material distribution

Augers	Left and right side separately controllable
Drive	Hydrostatic external drive, continuously controllable independent from the conveyor Auger halves can be switched to opposite directions
Conveying volume controller	Fully automatic via configurable switching points
Auger height adjustment	- mechanically via chain - mechanically (option) hydraulically (option)
Auger extension	With extension parts (see auger extension chart)

5.13 Screed lifting device

Special functions	At standstill: - Screed stop - Screed stop with pretensioning (max. pressure 50 bar) During paving: - Screed charging - Screed relieving (max. pressure 50 bar)
Levelling system	Mechanical grade control, optional systems with and without slope control

5.14 Electrical system

On-board voltage	24 V
Batteries	2 x 12 V, 88 Ah
Alternator (o)	17 kVA / 400 V 20 kVA / 400 V
Fuses	see chapter F, section 5

A For the filling volumes of lubricating and operating agents, see chapter F.

6 Location of instruction labels and identification plates

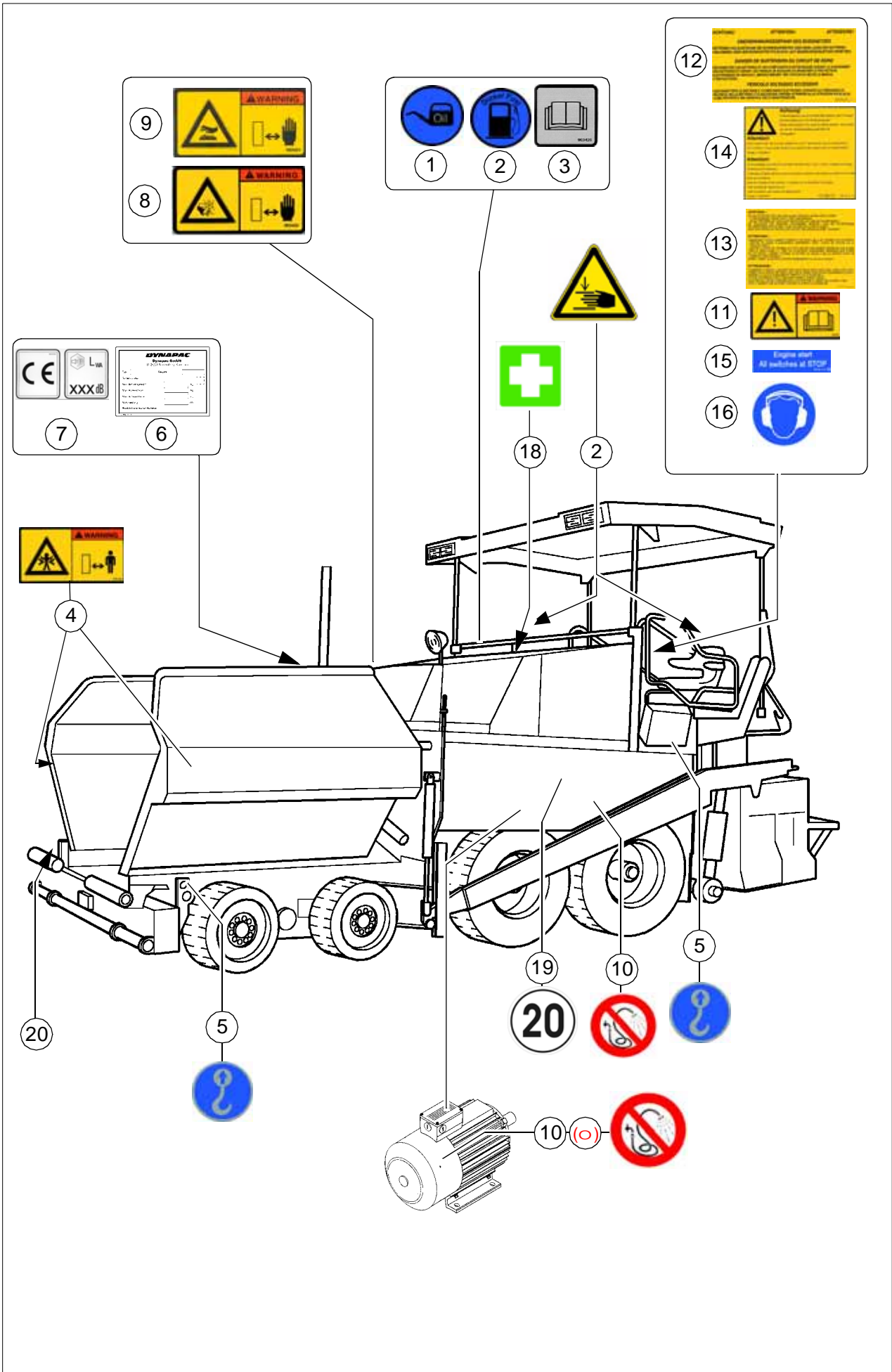

No.	Denomination
1	Label "Filler neck for diesel fuel" *
2	Label "Filler neck for engine oil" *
3	Label „Heed the operating instructions!“
4	Warning label "Danger of squeezing!" **
5	Punched vehicle identification number
6	Label "Securing or fixing points for crane transportation" **
7	Paver finisher identification label
8	„CE + noise level“ plate (O)
9	„Fan danger!“ warning plate
10	„Spraying with water prohibited“ plate
11	Label „Heed the operating instructions!“ ***
12	Label "High voltage!"
13	Label "Operating instructions for the engine"
14	„Crossbeam lock“ plate
15	„All switches to STOP“ plate ***
16	Label „Wear Ear Mufflers“
17	Label „Risk of hand injury“
18	Label „First Aid Box“ (O)
19	Label „20km/h“ (O)
20	Punched vehicle identification number

* Labels are located beneath the engine hood / maintenance flap

** Labels are located on both sides of the paver finisher

*** Label is located on the operating panel, above the steering wheel

6.1 Identification label for the paver finisher (7)

The diagram shows a rectangular identification label for a Dynapac paver finisher. At the top, it features the **DYNAPAC** logo and the company name **Dynapac GmbH**, along with the address **D-26203 Wardenburg · Germany**. Below this, there are several fields for technical specifications, each with a corresponding number in a circle pointing to it:

- 1**: Points to the **Typ** (Type) field.
- 2**: Points to the **Baujahr** (Year of manufacture) field.
- 3**: Points to the **Seriennummer** (Serial number) field.
- 4**: Points to the **Max. Betriebsgewicht** (Max. permissible operating weight) field, with a unit of **kg**.
- 5**: Points to the **Max. Achslast vorn** (Max. permissible load on the front axle) field, with a unit of **kg**.
- 6**: Points to the **Max. Achslast hinten** (Max. permissible load on the rear axle) field, with a unit of **kg**.
- 7**: Points to the **Motorleistung** (Rated performance) field, with a unit of **kW**.
- 8**: Points to the **Produkt Identifikation Nummer** (Product identification number) field.

At the bottom left of the label, there is a small reference code: **D 990 00 03 01**. The file name **Fertiger3.tif** is noted at the bottom left of the entire diagram area.

No.	Denomination
1	Type of paver finisher
2	Year of manufacture
3	Serial number of the paver finisher series
4	Max. permissible operating weight, incl. all attachments, in kg
5	Max. permissible load on the front axle, in kg
6	Max. permissible load on the rear axle, in kg
7	Rated performance in kW
8	Product identification number (PIN)

A The punched vehicle identification number on the paver finisher must match the product identification number (8).

7 EN standards

7.1 Continuous sound level

m The operator always must use ear protection. The imission value at the ear of the driver varies depending on the materials used for paving and may even rise above 85 dB (A). If no ear protection devices are used, hearing can be impaired. The noise emission level of the paver finisher was measured under free-field conditions according to EN 500-6 draft, dated March, 1997, and ISO 4872.

**Sound pressure level at the operator's position
(at the height of the head):**

$$L_{AF} = 83,7\text{dB(A)}$$

Sound capacity level:

$$L_{WA} = 108,0 \text{ dB(A)}$$

Sound pressure level at the machine

Measuring point	2	4	6	8	10	12
Sound pressure level L_{AFeq} (dB(A))	77,0	74,0	72,4	73,4	70,6	72,7

7.2 Operating conditions during measurement

The diesel engine was running at maximum speed. The screed was in working position, lowered to a rubber mat. The tamper and the vibrator were running at min. 50% of their maximum speed, the augers at min. 40% and the conveyors at min. 10% of their maximum speed.

7.3 Measuring point configuration

Semispherical measuring surface with a radius of 16 m. The machine was at the center. The measuring points had been assigned the following coordinates:

	Measuring points 2, 4, 6, 8			Measuring points 10, 12		
Coordinates	X	Y	Z	X	Y	Z
	±11,2	±11,2	1,5	- 4,32	+10,4	11,36
				+4,32	-10,4	11,36

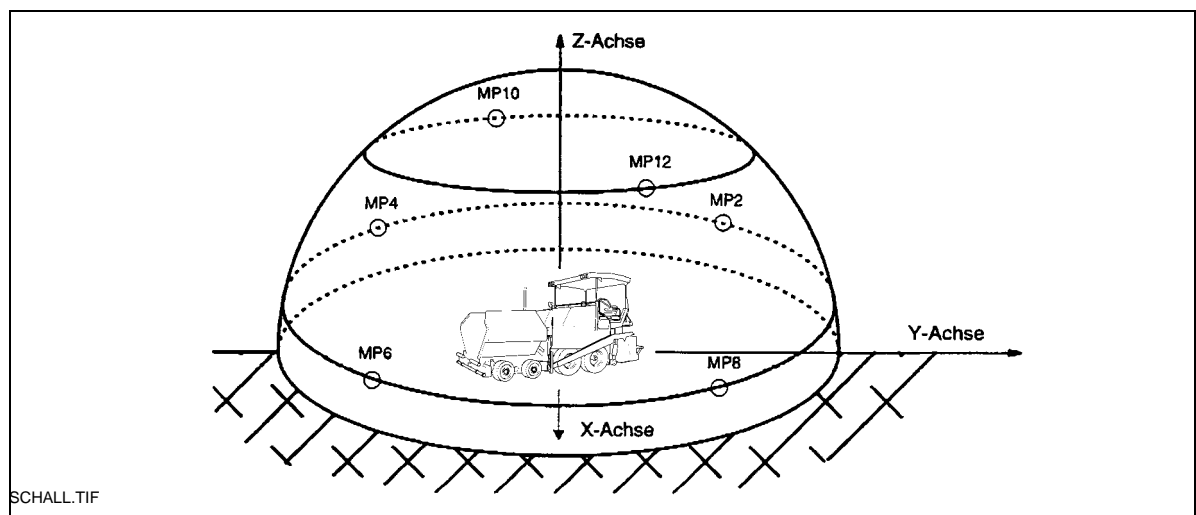

7.4 Vibration acting on the entire body

When the machine is used properly, the weighted effective acceleration values at the driver's seat of $a_w = 0.5 \text{ m/s}^2$ according to EN 1032-1995 draft are not exceeded.

7.5 Vibrations acting on hands and arms

When the machine is used properly, the weighted effective acceleration values at the driver's seat of $a_{hw} = 2.5 \text{ m/s}^2$ according to EN 1033-1995 draft are not exceeded.

7.6 Electromagnetic compatibility (EMC)

The following limit values are observed according to the stipulations of the EMC directive 89/336/EEC/08.95:

- Interference emission according to DIN EN 50081-1/03.93:
 - < 40 dB $\mu\text{V/m}$ for frequencies of 30 MHz - 230 MHz measured at a distance of 3 m
 - < 47 dB $\mu\text{V/m}$ for frequencies of 20 MHz - 1 GHz measured at a distance of 3 m
- Interference immunity against electrostatic discharge according to DIN EN 61000-4-2/03.96 (ESD):
 - The paver finisher did not show any discernible reactions to contact discharges of $\pm 4 \text{ KV}$ and to air discharges of $\pm 8 \text{ KV}$.
 - The modifications according to test criterion „A“ are being met, i.e. the paver finisher continues to work without malfunction during the test.

A Electrical or electronic components and their arrangement may only be modified after written approval by the manufacturer has been obtained.

C 1.2 Transportation

1 Safety regulations for transportation

m Accidents can happen when the paver finisher and the screed are not properly prepared for transportation or when transportation is carried out improperly!

Reduce both the paver finisher and the screed to their basic widths. Remove all protruding parts (such as the levelling device, auger limit switches, aprons, etc.). When transporting under a special permit, secure these parts!

Close the hopper lids and engage the hopper transport safeguards. Lift the screed and engage the screed transport safeguards. Convert the protective roof and engage the latch.

Check that the clamping device for the auger frame is fastened and that the telescopic tube cannot slide out (see chapter E, section 2.5).

Pack all parts that are not permanently fixed to the paver finisher and the screed into the appropriate boxes and into the hopper.
Close all coverings and check that they are securely seated.

In Germany, gas bottles must not be transported on the paver finisher or on the screed.

Disconnect the gas bottles from the gas system and protect them with their caps. Use a separate vehicle to transport them.

When loading via ramps, the paver finisher may slip aside, tilt or topple over. Drive carefully! Keep the danger area free of persons!

Additional stipulations for transportation on public roads:

m Wheel type paver finishers may travel on public roads along short sections only in the Federal Republic of Germany.

On machines with a gas screed, the two lower floorboards of the screed need to be removed and placed in the front hopper.

On machines with an electric screed, the two lower floorboards of the screed and ladder need to be removed and placed in the front hopper.

m Note that in other countries different regulations may apply.

The operator must be in the possession of a valid permit for vehicles of this type.

The operating panel must be moved to the side of the oncoming traffic and secured in this position.

The driving lights must be properly adjusted.

Only attachments and accessories may be transported in the hopper, no material or gas bottles!

If necessary, the operator must be assisted by a second person when driving on public roads – especially at road crossings and junctions.

2 Transportation on low-bed trailers

m Reduce the paver finisher and the screed to their basic widths; also remove any attached side plates. In order to prevent damage to the screed, the grade of the drive-up ramp can be max. 11° (19 %).

2.1 Preparations







- Prepare the paver finisher for transportation (see chapter D).
- Remove all protruding or loose parts from the paver finisher and the screed (see also the operating instructions of the screed). Store these parts in a safe place.

f When screed is operated with the optional gas heating system:

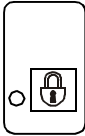
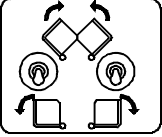
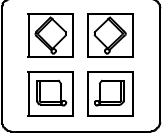
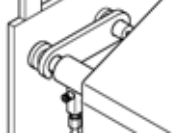
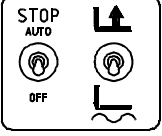
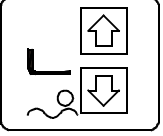
- Remove the gas bottles of the screed heating system:
 - Close the main shut-off valves and the bottle valves.
 - Unscrew the valves on the bottles and remove the gas bottles from the screed.

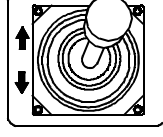
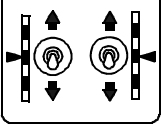
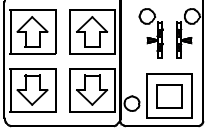

- Transport the gas bottles on a second vehicle; heed all pertaining safety regulations.

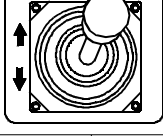
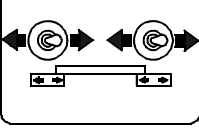
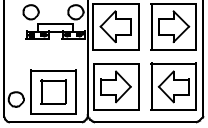
	Operation	Switch	Buttons
	- Disabling the interlocking of operation		
	- Close the hopper halves.		
	- Engage both hopper transport safeguards.		
	- Lift the screed.		
	- Insert the transportation safeguards of the hopper!		
A Only in case of not connected remote control	- Turn the preselecting regulator to zero.		
	- Move the drive lever forward.		
	- The levelling cylinders are completely extended.		
	- Set the drive lever to mid-position.		
	- Retract the screed to the basic width of the paver.		

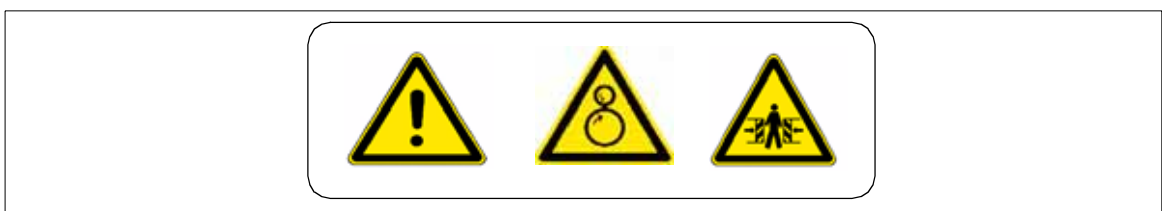

2.2 Drive onto the low-bed trailer

- f Make sure that there are no persons in the danger area during loading.

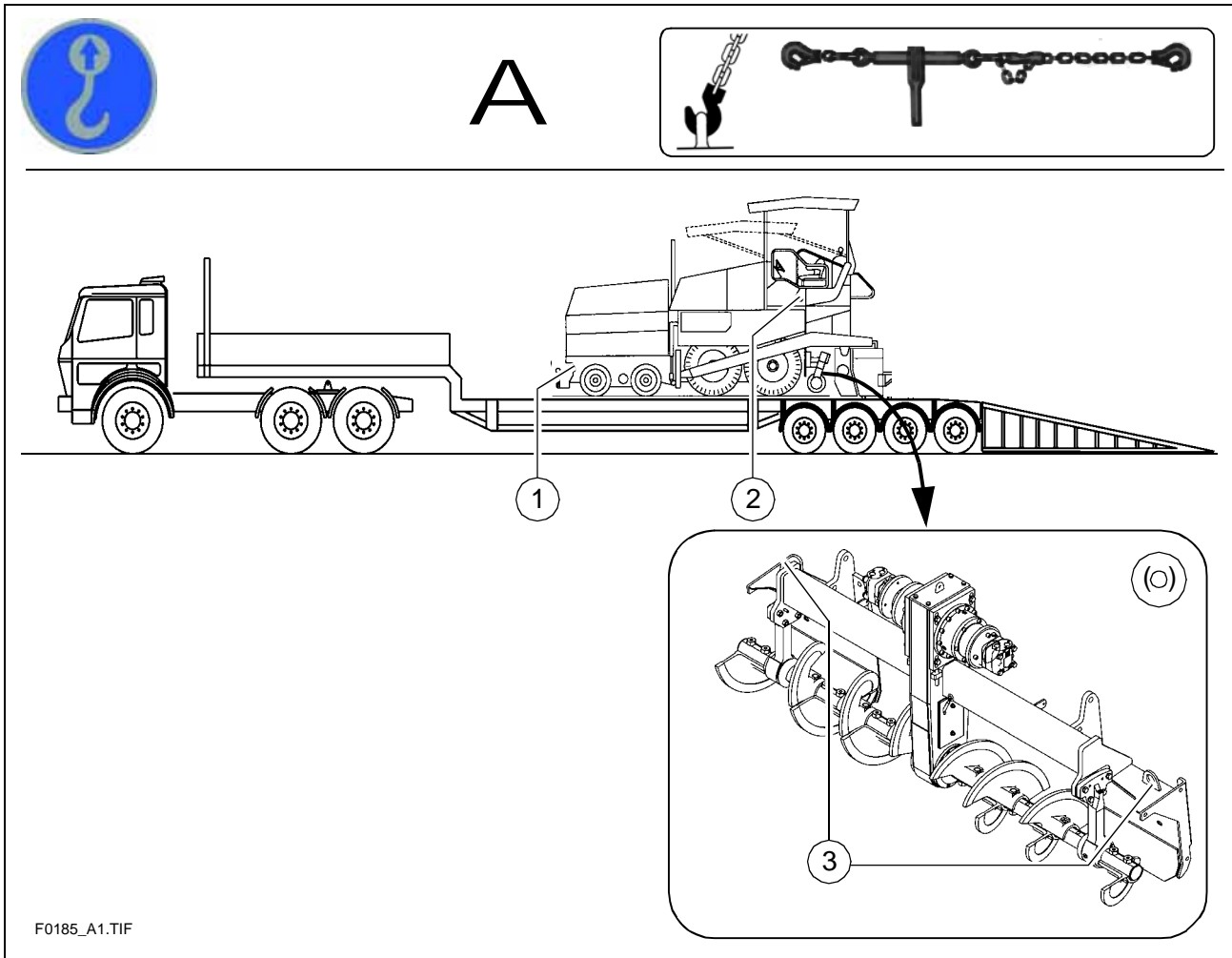

- Use the work gear and low engine speed to drive onto the low-bed trailer.
- Lower the screed onto wooden blocks on the low-bed trailer.
- Switch off the paver finisher.
- Attach and secure the protective hood to protect the operating panel.
- If necessary, swing down the protective roof:
 - Take out the bolts and pull the roof to the front by gripping it with the bow-type handle. When it is in the lower position, secure it with the bolts.

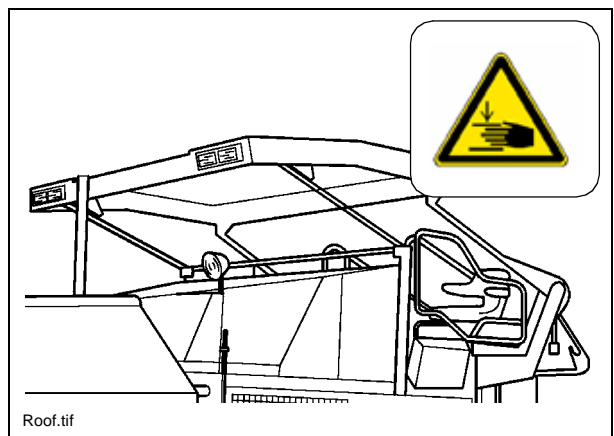

2.3 Secure the paver finisher in its position to the low-bed trailer:

- Use only proper and permitted load fastening devices.
- Use the four securing points provided (1, 2).

A Depending on the equipment of the machine there can be further support points (3) on the auger frame (3)!

- Wait until the exhaust extension pipe has cooled down; then remove it and store it.

2.4 After transportation

- Remove the attachment devices.
- Swing up the protective roof: take out the bolts, push the protective roof forward to raise it and insert the bolts to lock it again.
- Mount the protective tarpaulin if it has been removed.
- Lift the screed to the transportation position and lock it.
- Start the engine and drive from the trailer at a low engine/traction speed.
- Park the paver finisher in a secure spot, lower the screed and switch off the engine.
- Remove the key and/or cover the operating panel with the protective hood and secure it.

3 Transportation

m Reduce the paver finisher and the screed to their basic widths; also remove any attached side plates.

3.1 Preparations

- Prepare the paver finisher for transportation (see chapter D).
- Remove all protruding or loose parts from the paver finisher and the screed (see also the operating instructions of the screed). Store these parts in a safe place.







f When screed is operated with the optional gas heating system:

- Remove the gas bottles of the screed heating system:
 - Close the main shut-off valves and the bottle valves.
 - Turn off the valves on the bottles and remove the gas bottles from the screed.
- Transport the gas bottles on a second vehicle; heed all pertaining safety regulations.

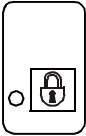
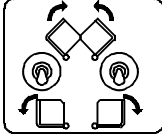
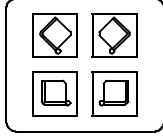
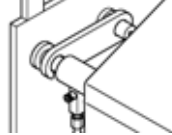
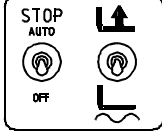
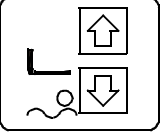

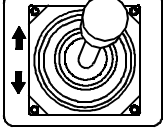
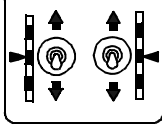
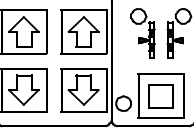

3.2

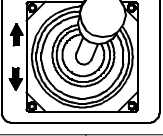
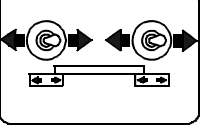
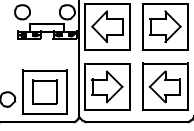
t

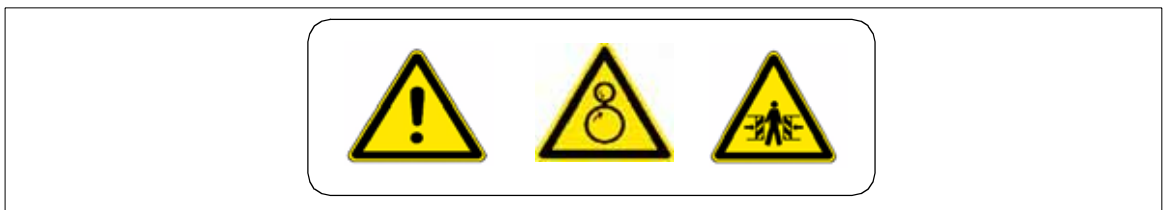
	Operation	Switch	Buttons
	- Disabling the interlocking of operation		
	- Close the hopper halves.		
	- Engage both hopper transport safeguards.		
	- Lift the screed.		
	- Insert the transportation safeguards of the screed.		
A Only when remote control is not connected.	- Turn the preselecting regulator to zero.		
	- Move the drive lever forward.	 	
	- The levelling cylinder are in fully extended position.		
	- Set the drive lever to mid-position.	 	
	- Retract the screed to the basic width of the paver finisher.		

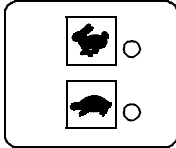

ion drive

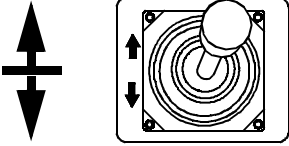
Warning	Marking	Marking
<ul style="list-style-type: none"> - Set the Fast/Slow switch to „Hare“. 		
<ul style="list-style-type: none"> - Turn the preselecting regulator to maximum. 		
<ul style="list-style-type: none"> - Use the drive lever to regulate the speed. 		

f Risk of accident!

- Do not travel with the differential lock engaged.
- In tight curves avoid sudden steering movements. Moving the steered wheels to locking position requires about 2.5 - 3 full steering wheel turns.
- Press the emergency stop button when a dangerous situation arises!

f When pressing the emergency button the paver, the engine stops and steering becomes very difficult. This may lead to accidents!

4 Loading by crane

- m Use only lifting gear that can bear the load.
(See Chapter B for weights and dimensions).

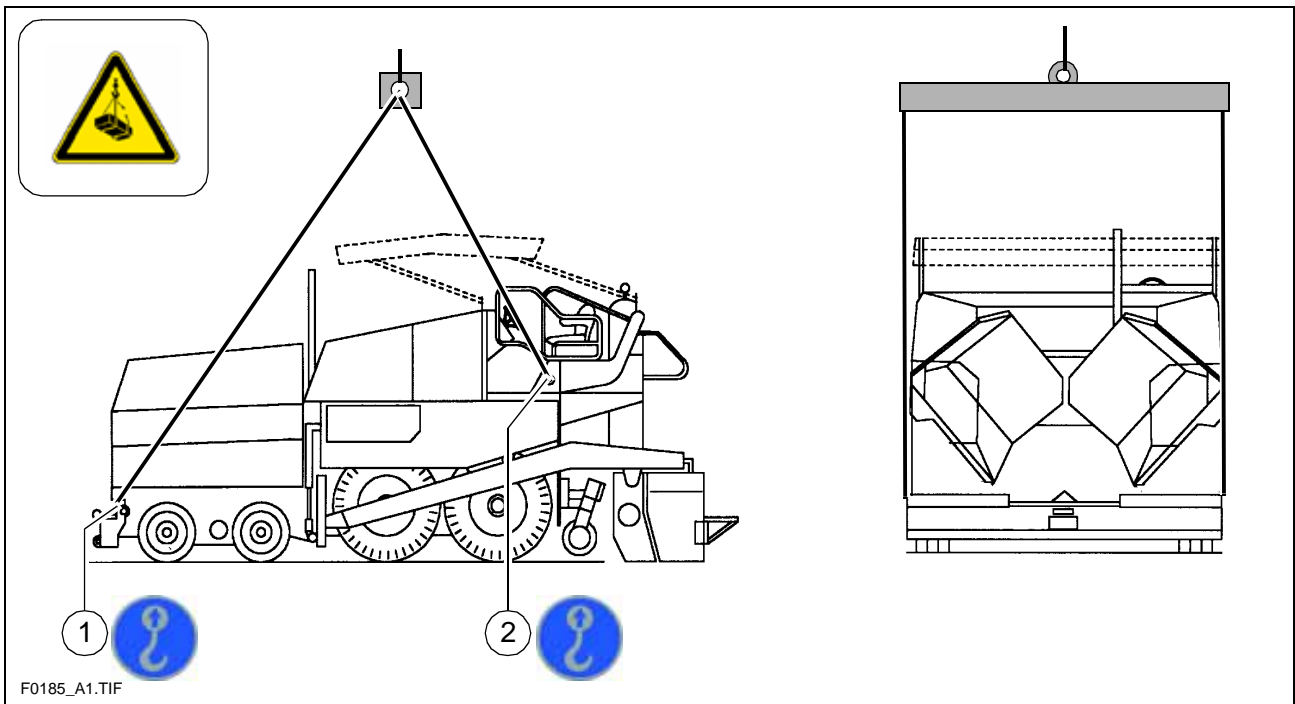

- A Four lifting eyes (1,2) are provided for loading the vehicle with a crane.

- Park the paver finisher and render it safe.
- Engage the transport safeguards.
- Remove any attachments and accessories from the paver finisher and the screed until the basic width has been attained.
- Take off all protruding or loose parts and the gas bottles of the screed heating system (see Chapters E and D).
- Swing down the protective roof.
- Attach the lifting gear to the four lifting eyes (1,2).

- m Make sure that the paver finisher remains in a horizontal position during transport!

5 Towing

f Heed all regulations and apply all safety measures applicable for towing heavy construction machines.

m The towing vehicle must be capable of securing the paver, even on slopes.

Use only approved tow bars!

If necessary, remove any attachments and accessories from the paver finisher and the screed until the basic width has been attained.

Set the two-stage transmission using lever (1) to position „0“.

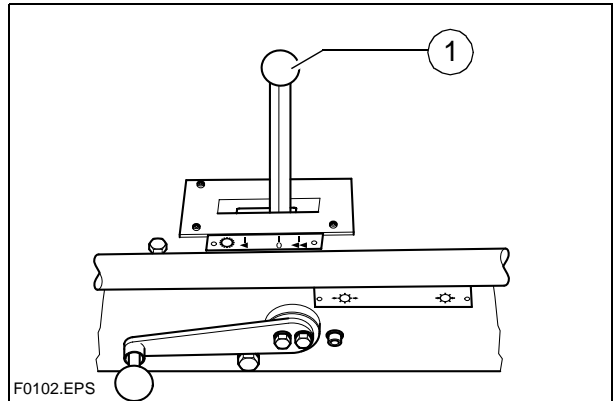

- Attach the tow bar to the coupling (2) located in the bumper.
- Slowly and carefully tow the paver finisher from the construction site or the hazardous area via the shortest route

A Now carefully and slowly tow the paver finisher out of the construction area.

m Always only tow the shortest distance to the means of transport or the next parking possibility.

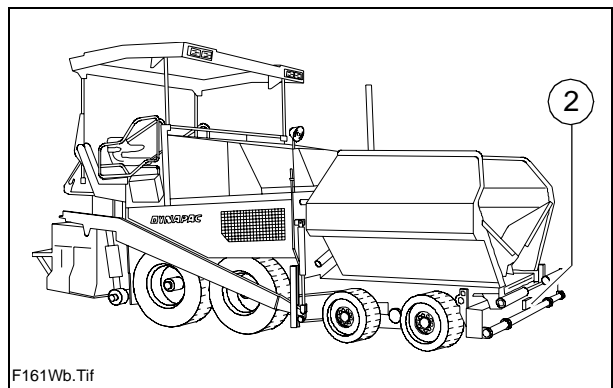

6 Safely parking the vehicle

m When the equipment is parked at a location accessible to the public, it must be secured in such a way that unauthorized persons or playing children cannot damage the vehicle.

- Pull off the ignition key and the main switch (1) and take it with you – do not hide them somewhere on the machine.

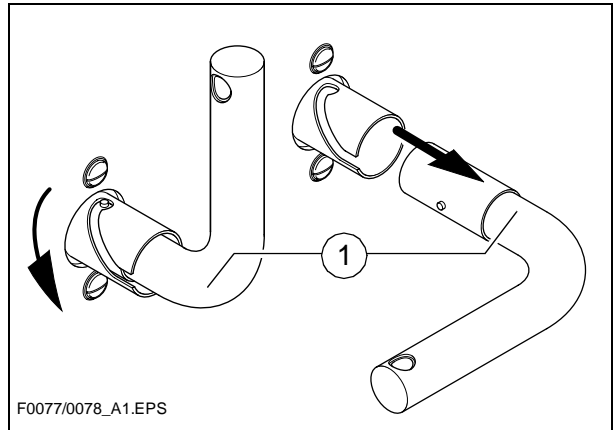

m Do not turn off main switch (1) until 15 seconds after the ignition has been turned off!

A The engine electronics need this length of time to back up data.

- Protect the operating panel with the dust cover (2) and lock it.
- Store loose parts and accessories in a safe place.

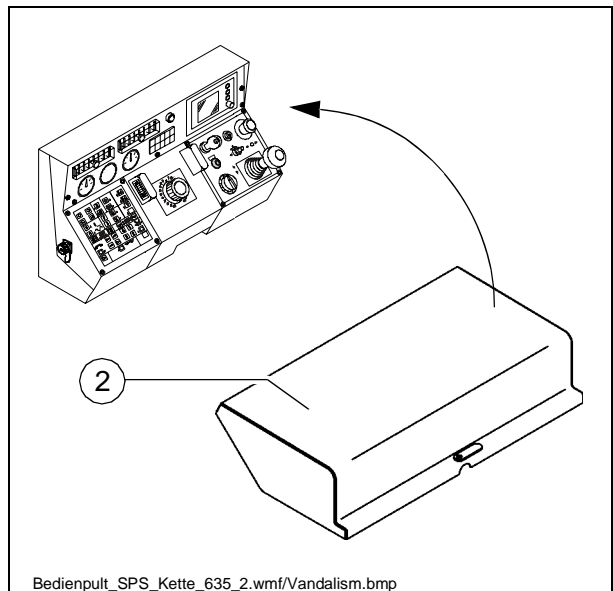

A Secure the dust cover (2) during operation with the lock on the terminal box under the maintenance flap on the RH side!

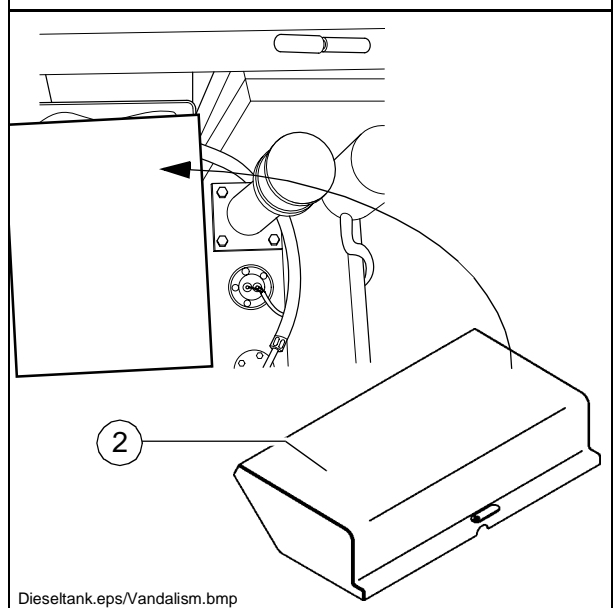

D 1.0 Operation

1 Safety regulations

- f Starting the engine, the traction drive, the conveyor, the auger, the screed or the lifting devices can cause injuries or even the death of persons.
Make sure before starting any of these devices that no-one is working at, in or beneath the paver finisher or within its danger area!
 - Do not start the engine or do not actuate any controls when this is expressly forbidden!
Unless otherwise specified, the controls may only be actuated when the engine is running!

- f Never crawl into the auger tunnel or step into the hopper or onto the conveyor. Danger to life and limb!
 - Always make sure during operation that no-one is endangered by the machine!
 - Ensure that all protective covers and hoods are fitted and secured accordingly!
 - When damages are detected, eliminate them immediately! Operation must not be continued when the machine is defective!
 - Do not let any persons ride on the paver finisher or the screed!
 - Remove obstacles from the road and the work area!
 - Always try to choose a drivers's position that is opposite to the flowing traffic! Lock the operating panel and the driver's seat.
 - Keep a sufficient safety clearance to overhanging objects, other machines and points of danger!
 - Be careful when travelling on rough terrain to keep the paver finisher from slipping, tipping or turning over.

- f Always be the master over the machine; never try to use it beyond its capacities!

2 Operating elements

2.1 Operating panel

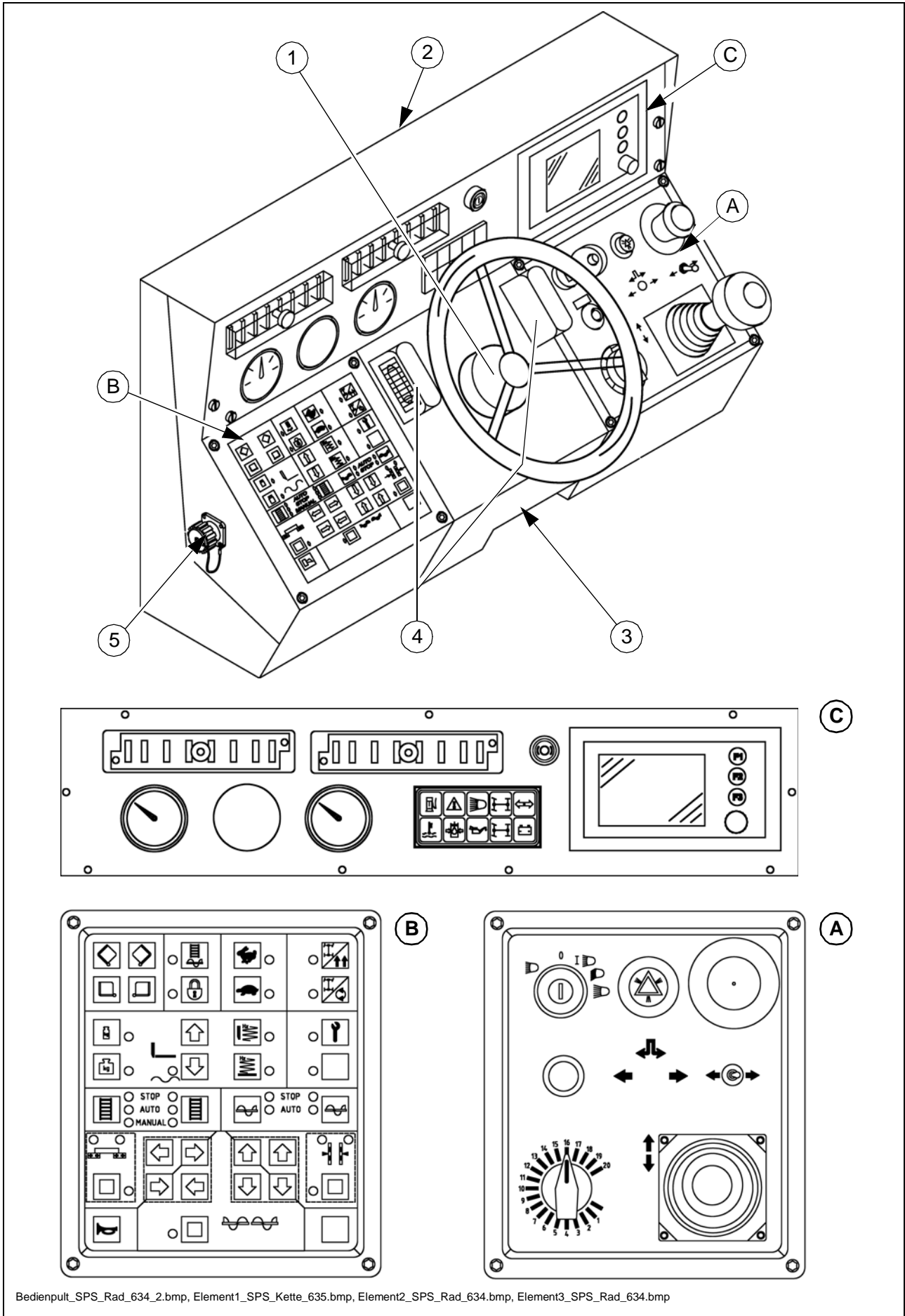

m General notes on the observation of CE regulations

All functions of self-engaging buttons which might provoke a risk during start-up of the diesel engine (conveying function of auger and conveyor) are set to STOP in case of an emergency stop or a control restart. Changes of settings which are performed when the diesel engine is at a standstill („AUTO” or „MANUAL”) are reset to „STOP” when the diesel engine is started.

Turning on the spot (button 19) is reset to straight-ahead travel.

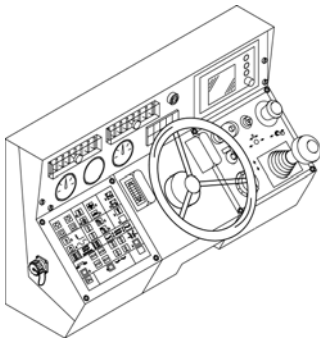

Item	Designation	Brief description
1	Steering	Steering is transmitted to the front wheels hydraulically. ⚠ When travelling in tight curves, take care of the special steering ratio (about 3 turns for changing between steering locks) Risk of accident!
2	Retaining bracket for operating panel	For securing the movable operating panel against inadvertent movement at the desired paver finisher height. - Turn the knurled screw at the desired location into the designated notch and secure with the knurled nut. ⚠ When not secured, the operating panel can move. Danger of accidents during transportation!
3	Latch for operating panel	In the case of seats which can be swung out beyond the machine contour (option), the operating panel can also be moved beyond the basic width of the paver finisher. Pull out the latch and move the operating panel; let the latch engage again. ⚠ An unlatched operating panel can slide out of position. Danger of accidents during transportation!
4	Lights	Lights up instrument panel A / B when the parking light is switched on.
5	Connection	To connect input devices.

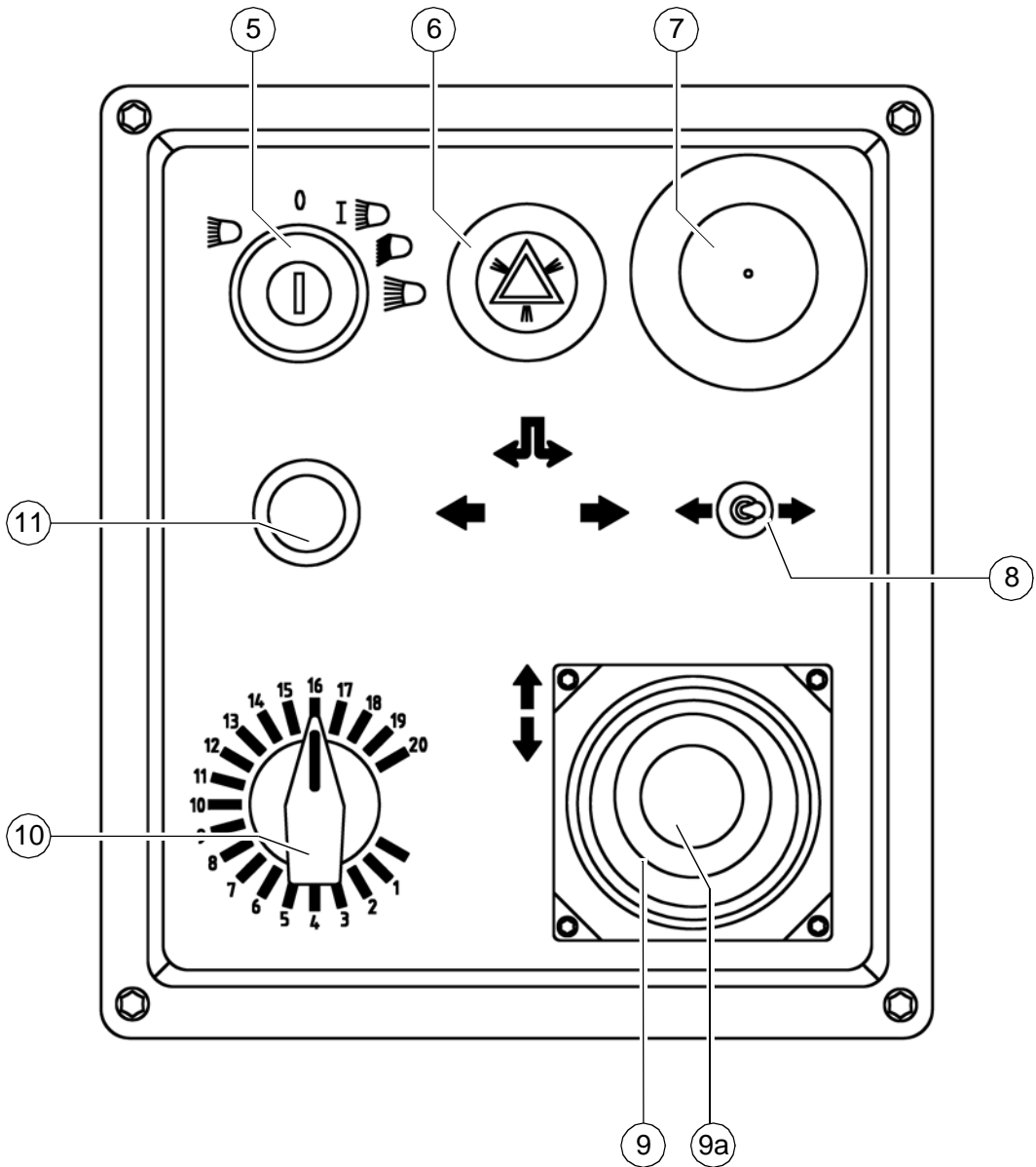

A



Element2_SPS_Rad_634.bmp

Item	Designation	Brief description
5	Ignition lock and illumination switch	<p>Positions:</p> <p>0 Ignition and light off</p> <p>1 Ignition on</p> <p> Parking/rear lights, instrument panel illumination, working lights (if applicable)</p> <p> Driving light</p> <p> High beam</p>
6	Warning signal	Switch on for safety on roads.
7	Emergency stop button	<p>In the case of an emergency (danger to persons, possible collision etc.), press in the button!</p> <ul style="list-style-type: none"> - Pressing the emergency stop button switches off the engine, the drives and the steering system. Making way, lifting the screed or other actions are then no longer possible! Danger! - The emergency stop button does not shut off the gas heater system. Close the main shut-off valve and the valves on the bottles by hand! - In the case of electrical malfunctions, the engine must be turned off manually at the leverage of the injection pump. To restart the engine, the button must be pulled out again.
8	Travelling direction indicator („Direction indicator“)	<ul style="list-style-type: none"> - Use it when changing direction along public road.

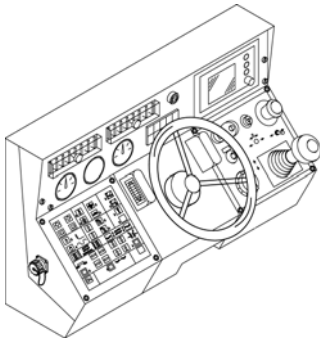

A

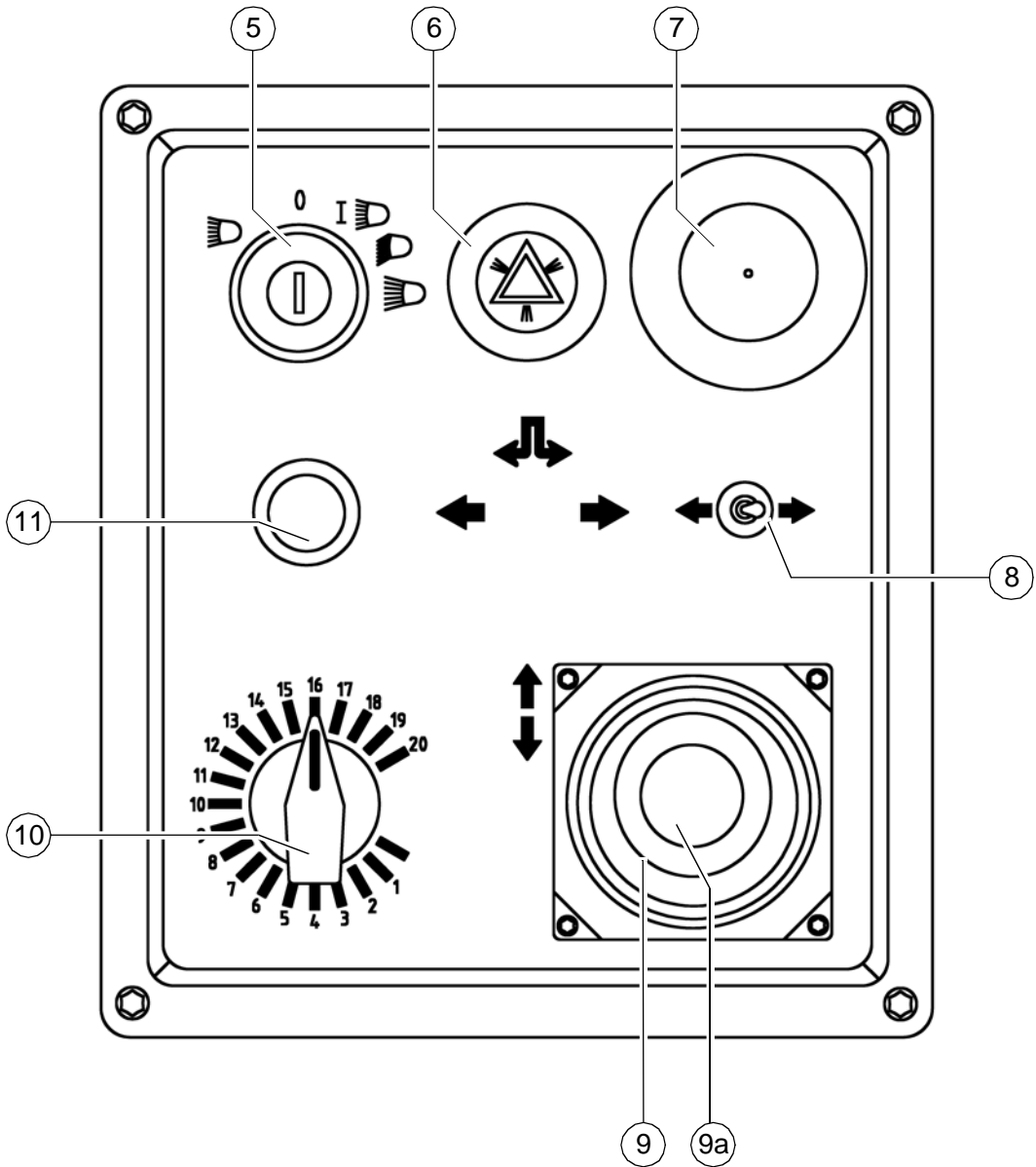

Element2_SPS_Rad_634.bmp

Item	Designation	Brief description
9	Drive lever (feed)	<p>For switching on the paver finisher functions and for continuously regulating the traction speed – forward or reverse. Zero position: starting is possible; engine at idling speed; no traction drive</p> <p>For turning out, pull up the ring (9a).</p> <p>Depending on the position of the drive lever, the following functions can be activated:</p> <ol style="list-style-type: none"> 1. position: feeder and auger On. 2. position: screed movement (tamper/vibrator) turned on; traction drive engaged; increase speed until impact. <p>Use the preselector to set the maximum speed.</p> <p>A When the machine is stopped, the parking brake is automatically engaged.</p> <p>A When the drive lever is moved, the parking brake is automatically released.</p> <p>A If the machine was stopped by the service brake, it cannot be started again, before the drive lever is set to neutral position.</p>
10	Preselector, traction drive	<p>For setting the maximum speed that can be reached when the drive lever is at its stop.</p> <p>A The scale roughly matches the speed in m/min (during paving).</p>
11	Starter	<p>Starting is only possible when the driver lever is in the neutral position. All emergency stop buttons (on the operating panel and the remote controls) must be pulled out.</p>
12	has no function	

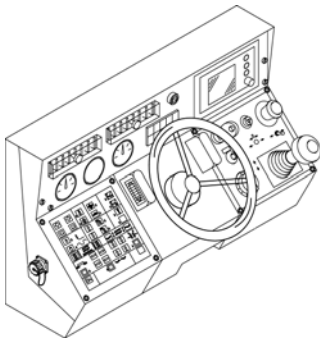

B

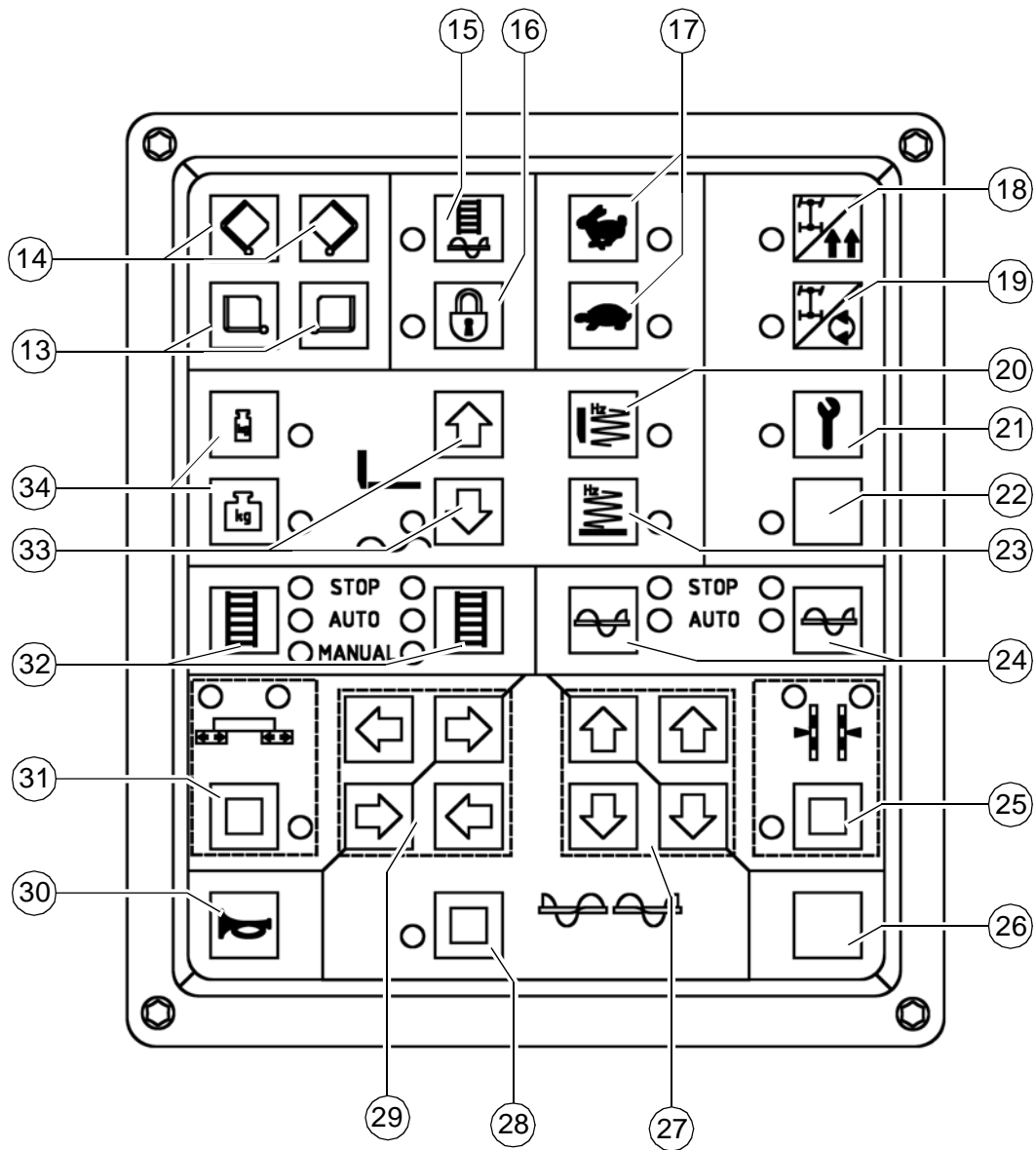

Item	Designation	Brief description
13	Open hopper	<p>Push-button: Left: open left hopper half Right: open right hopper half</p> <p>If both hoppers are hydraulically actuated at the same time (1 valve), either the left button or the right button can be used for operation.</p>
14	Close hopper	<p>Push-button: Left: close left hopper half Right: close right hopper half</p> <p>Separate actuation (○): Is required when paving in spaces where there is only limited space at one side or when obstacles obstruct unloading of the truck.</p>
15	Filling the machine for paving	<p>Self-engaging button with LED indication Operating requirements: button 16 „OFF”</p> <p>Button (15) is used for the filling function: - The diesel engine speed is increased to the preselected nominal speed and all conveying functions (conveyor and auger) which are set to „Automatic” can be activated.</p> <p>Switching off: Press button 15 again or tilt the drive lever to the paving position.</p>
16	Main function switch	<p>Self-engaging button with LED indication</p> <p>Button 16 locks all functions necessary for paving. Although the individual functions are set to „Auto”, they are not activated when the drive lever is moved.</p> <p>The set-up is retained, allowing the machine to be re-positioned and unlocked at the installation site. Paving can be continued by moving the drive lever.</p> <p>A Button 16 is set to „ON” when restarting.</p>

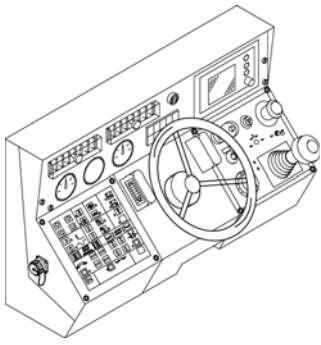

B

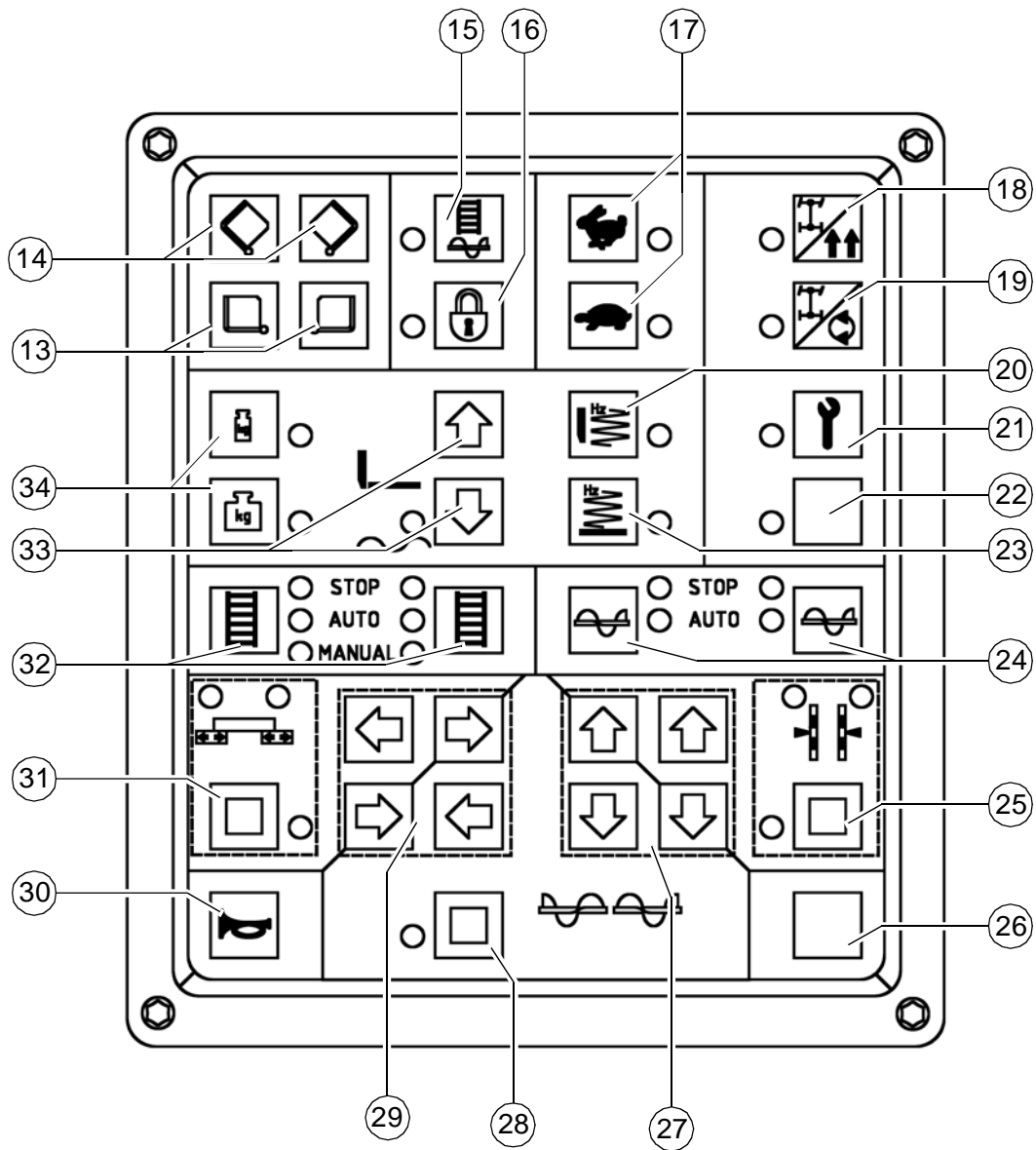

Item	Designation	Brief description
17	Machine drive fast/slow	<p>Self-engaging buttons with LED indication Hare: transport speed Tortoise: operating speed for paving</p> <p>A When restarting, the buttons are set to working speed (tortoise).</p> <p>A When the working speed is selected, the differential lock is automatically engaged!</p> <p>A When the travelling speed is engaged, the front wheel drive is automatically switched off!</p>
18	Front wheel drive On/Off (○)	<p>Buttons with locking switch function and LED control. This allows switching on and off of the supplementary front wheel drive.</p> <p>A Front wheel drive can be engaged only with the switch in working speed position.</p> <p>A See the valve and the pressure gauge for the adjustment of the drive pressure.</p>
19	has no function	
20	Tamper (screed-specific)	<p>Self-engaging button with LED indication Operating requirements: button 16 must be set to „OFF”</p> <p>Switching function ON or OFF. - The function is activated when moving the drive lever. Set-up operation is actuated in conjunction with button 21.</p>
21	Set-up operation	<p>When the machine is at a standstill, this button is used for the commissioning of all working functions which are only activated when the drive lever (travelling machine) is moving.</p> <p>- Button 21 „ON” Button 16 „OFF”</p> <p>The diesel engine speed is increased to the preselected set value.</p>

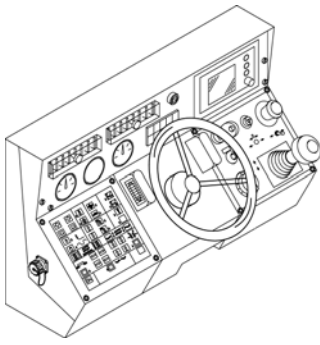

B

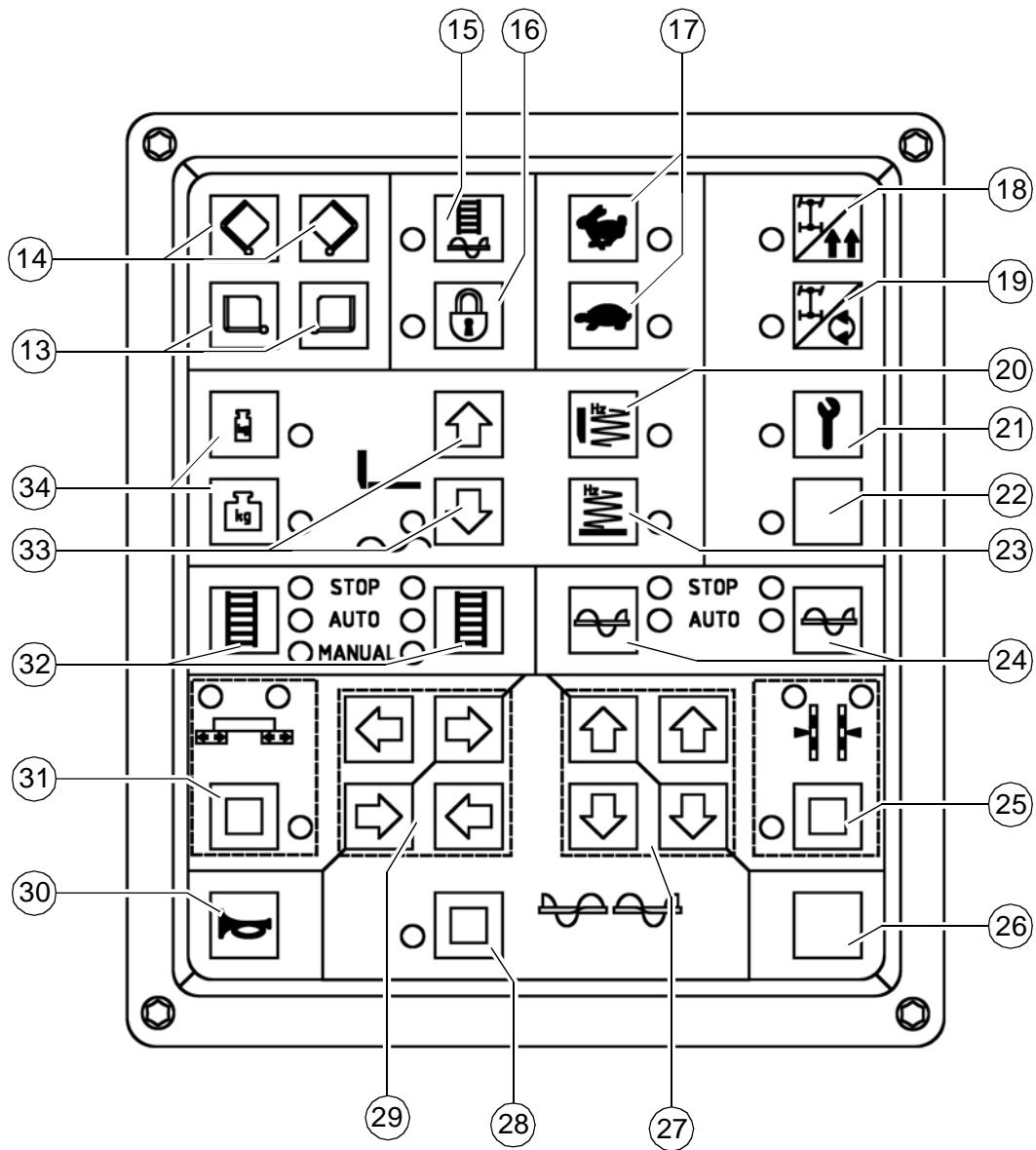

Item	Designation	Brief description
22	Not used	
23	Vibration	Operation and application: see button (20).
24	Auger left/right	<p>Self-engaging buttons with LED indication</p> <p>Toggling between two switching conditions. Stop: Operational readiness Auto</p> <p>Reset to STOP in case of an emergency stop or a restart. Button 16 locks the conveying function.</p>
25	Levelling cylinder left/right	<p>Self-engaging button with LED indication For manually actuating the levelling cylinders when automatic levelling is switched off. The switch on the remote control must be set to „manual“. LED „C“ (left) and LED „D“ (right) indicate the setting. Switched off by pressing the button again or by pressing button 28 or 31. Adjustment of the levelling cylinders occurs by using the appropriate button in the pad (right) for the directions of movement (27).</p> <p>A This function is active even if the remote control is disconnected!</p>
26	Not used	
27	Pad (right) for directions of movement	Used in conjunction with buttons 25, 28 and 31; releases a movement towards the indicated direction.

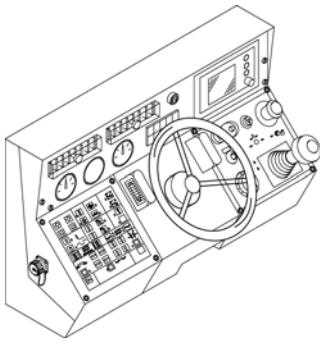

B

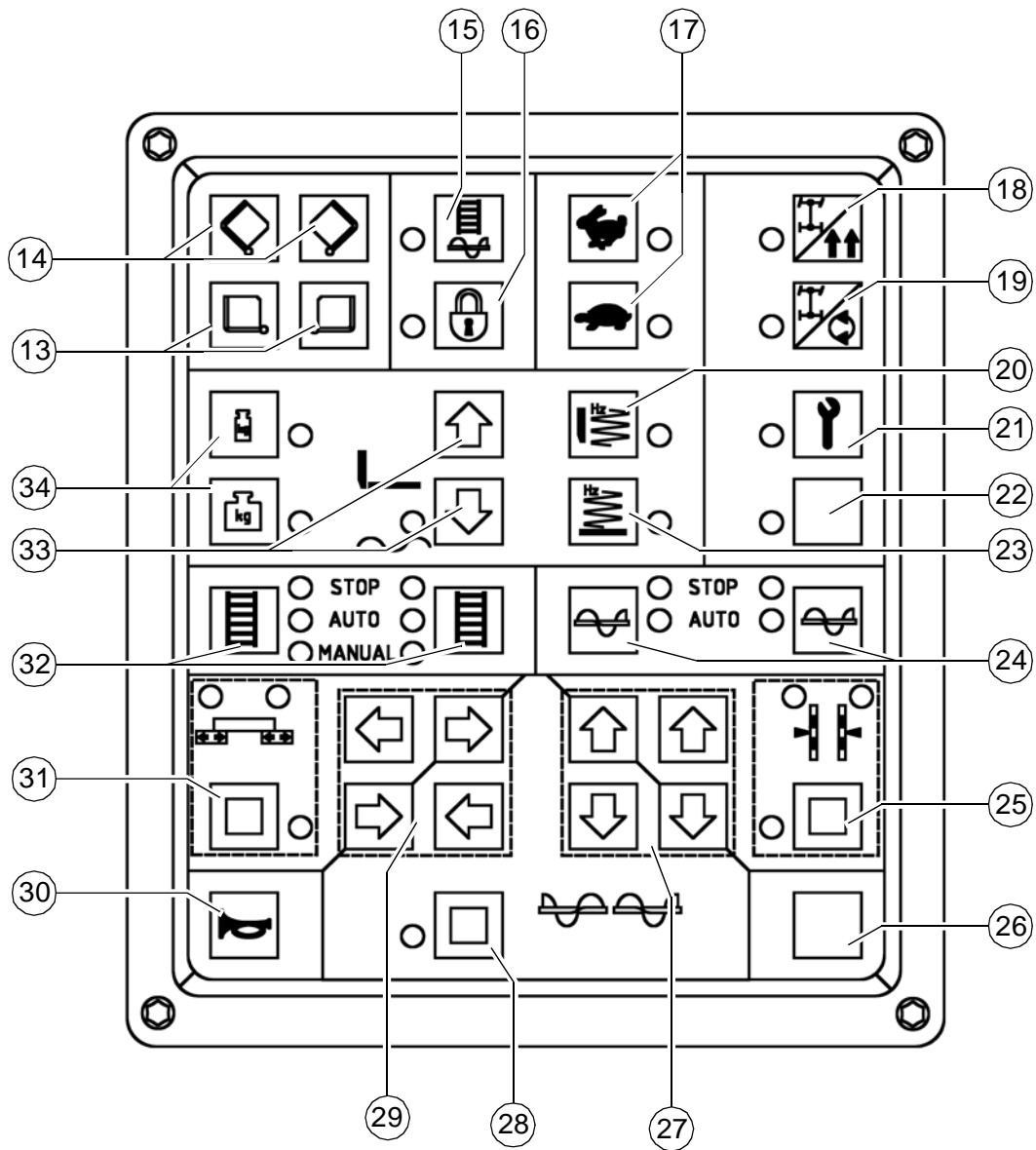

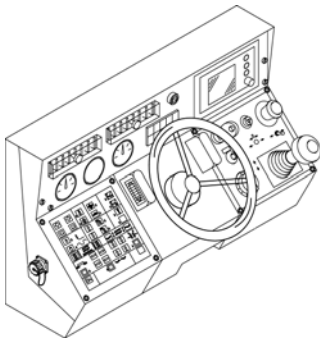

Item	Designation	Brief description
28	„MANUAL” auger operation and lifting/lowering the auger	<p>Self-engaging button with LED indication Switched off by pressing the button again or by pressing button 25 or 31.</p> <p>1. „MANUAL” auger operation Requirements: button 24 must be set to „AUTO” - Using the buttons in the pad (left) for the directions of movement (29), the conveying speed of the automatic function can be exceeded with full conveying performance in the direction of the corresponding arrow.</p> <p>2. Lifting/lowering the auger - Using the buttons in the pad (right) for the directions of movement (27), the auger is lifted or lowered to the direction of the arrow.</p>
29	Pad (left) for the directions of movement	Used in conjunction with buttons 25, 28 and 31; releases a movement to the indicated direction.
30	Horn	Must be activated in the case of emergencies and to indicate that the machine starts to move!
31	Extend/retract screed parts	<p>Self-engaging button with LED indication Switched off by pressing the button again or by pressing button 25 or 28.</p> <p>Using the buttons in the pad for the directions of movement, the screed is moved to the indicated direction of the arrow. LED „A” and LED „B” indicate the vario screeds.</p>
32	Conveyor, left/right	<p>Self-engaging buttons with LED indication To change between the three switching states, press the button again: STOP: Operational readiness AUTO MANUAL</p> <p>Reset to STOP in case of an emergency stop or a restart. Button 16 locks the conveying function.</p>

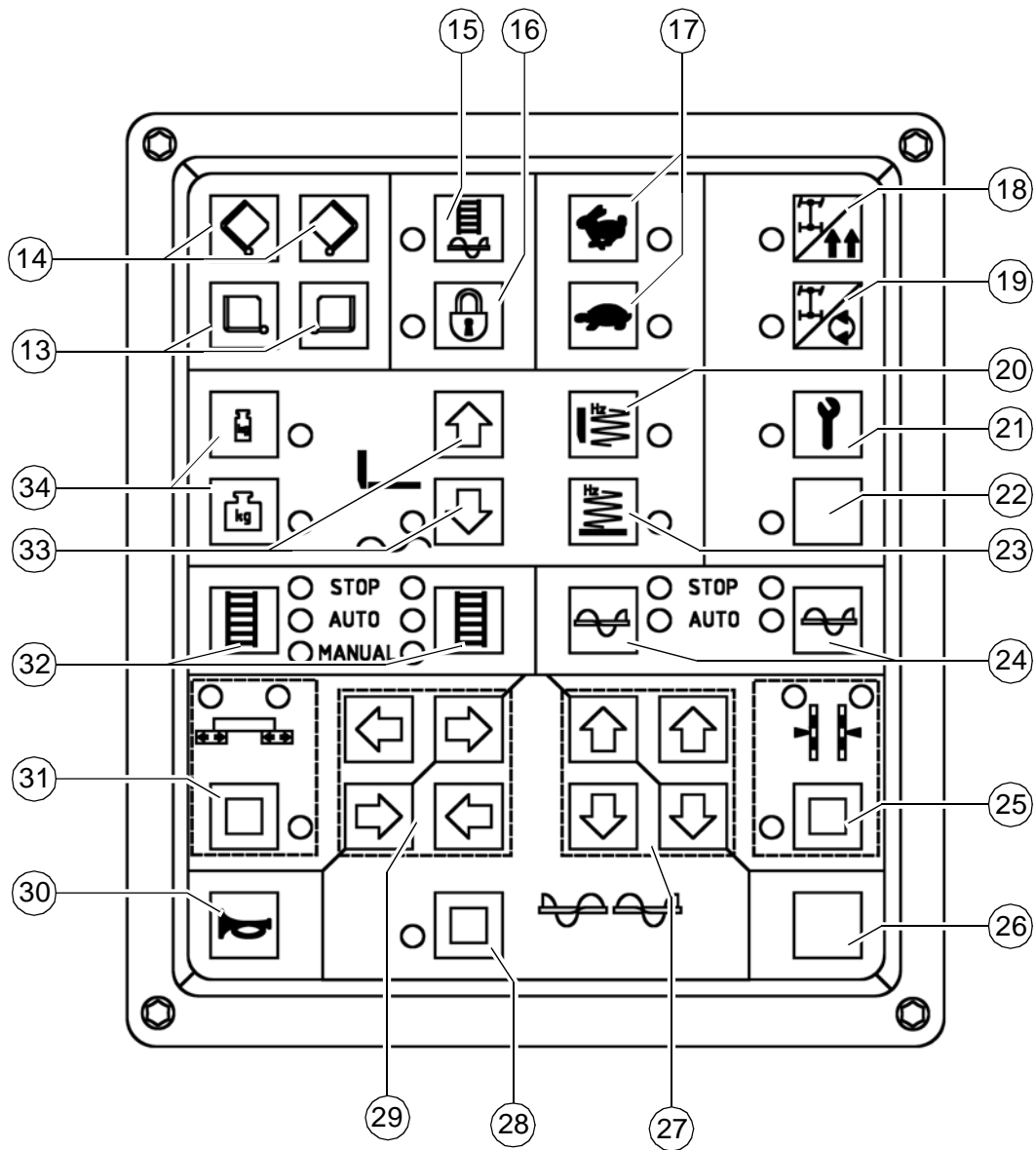

B



Item	Designation	Brief description
33	Screed position	 Push-button function Lift screed A If the drive lever is in its central position, the speed of the engine rises automatically when moving.  Self-engaging button with LED indication Lower screed/screed in floating position <p>The button 16 must be set to „OFF”</p> <p>Screed floating position: Pressing the button turns the LED ON and prepares the screed for „floating position”, which is activated by the actuated drive lever (9). Pressing the button again or pressing the button Lift screed turns the LED off.</p> <p>Lower screed:</p> <ul style="list-style-type: none"> - Button function: Keep the button depressed for more than 1.5 sec (LED On). As long as the button is pressed, the screed is lowered. When the button is released, the screed will stop again. (LED Off). - Resting function: Briefly press the button (LED On) - the screed is lowered. Press the button briefly again (LED Off) - the screed stops. <p>m During paving, the screed must always be in the floating position. In the intermission, the screed switches to stand-by position.</p>
34	Screed charging/relieving device	<p>Self-engaging buttons with LED indication Switched off by pressing the button again or by toggling between the two buttons.</p> <p>For charging/relieving the screed to influence traction and the compacting ratio.</p> <ul style="list-style-type: none"> - To pre-adjust the pressure of the hydraulic oil, set this button and button 21 to „ON”.

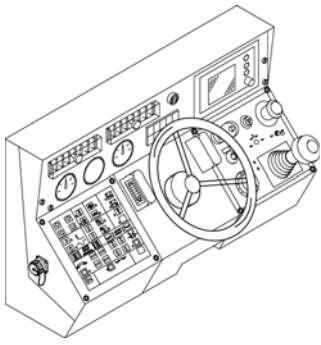

C

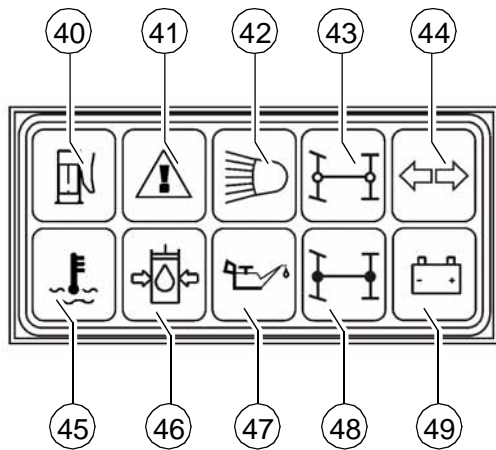
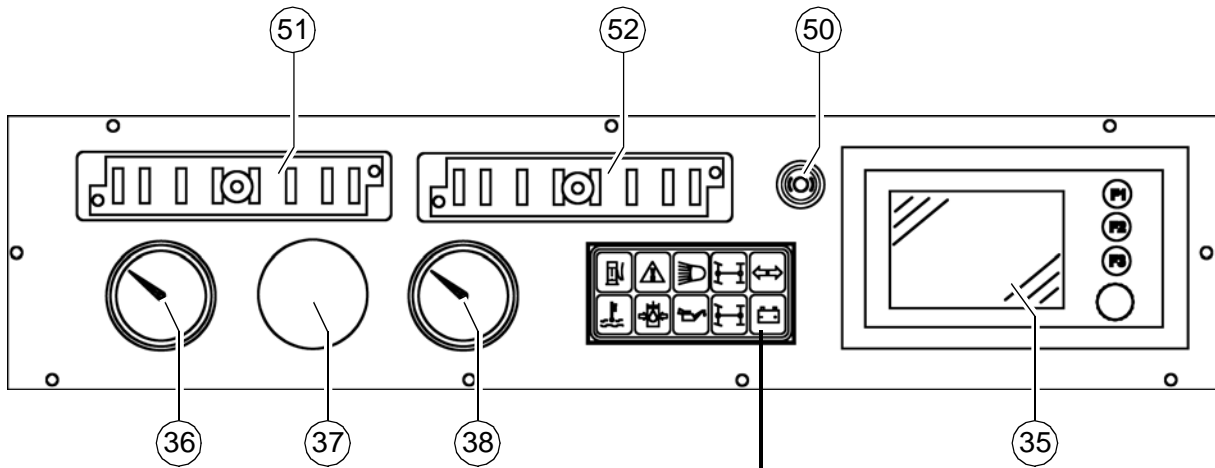

Element3_SPS_Rad_634.bmp/Leuchtmodul_SPS_Kette_635.bmp

Item	Designation	Brief description
35	Control setting and display terminal	To query, set and save various operating status and functions as well as for displaying messages related to machine and engine.
36	Hydraulic oil thermometer	Normal display up to 120 °C = 248 °F. m In case of higher temperature stop the machine, (set drive lever (9) to neutral position), and let the engine cool at idling speed. Find the cause and eliminate the fault.
37	Not used	
38	Fuel gauge	Always heed the fuel gauge. m Do not completely empty the diesel tank! Otherwise, the entire fuel system must be vented.

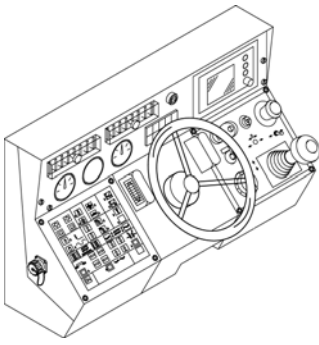

C

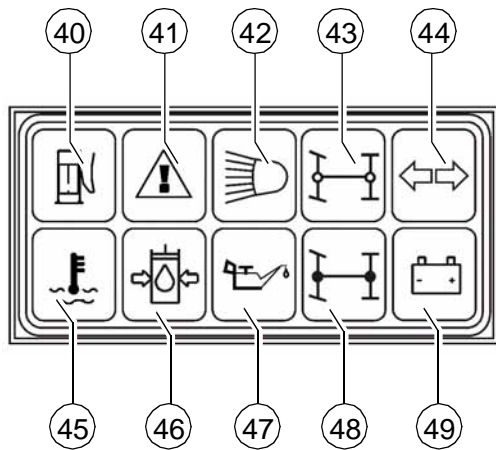
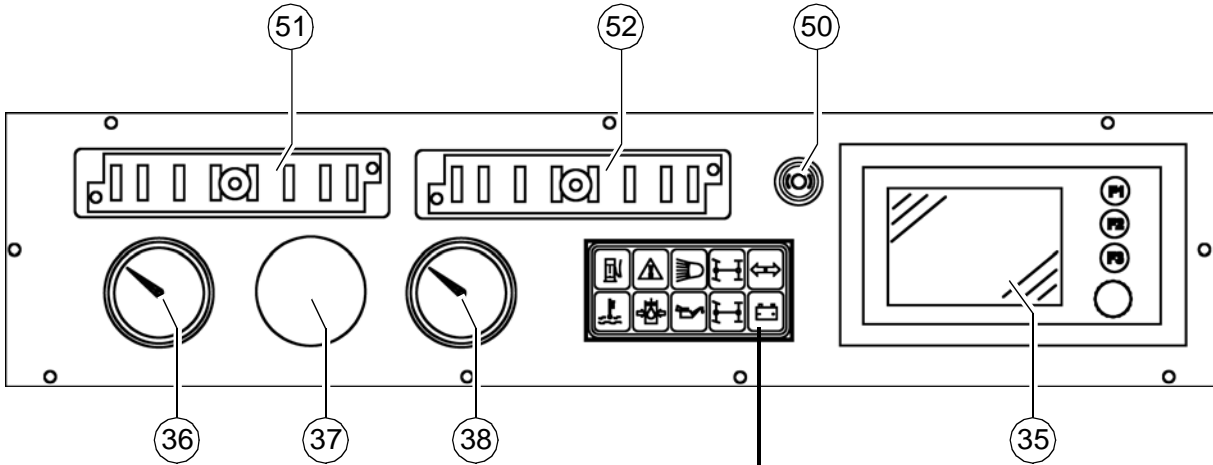

Element3_SPS_Rad_634.bmp/Leuchtmodul_SPS_Kette_635.bmp

Item	Designation	Brief description
40	Alarm light (red) „Water in the fuel“	<p>This light is on, if the water separator of the fuel system has established a too high water level.</p> <p>m In order to avoid the damage of the traction engine drain the separated water immediately according to the operation manual.</p> <p>A The fault is indicated together with the „Error message“ light.</p>
41	Error message (yellow)	<p>It indicates that a fault has occurred in the traction engine. Depending on the type of the fault the operation of the machine can be continued temporarily, or in case of a major fault it can be stopped immediately.</p> <p>All the faults shall be eliminated as soon as possible!</p> <p>A The error message is displayed on the setting and display terminal.</p> <p>A After the ignition is turned on, the light is on for a few seconds for check-up.</p>
42	High beam indicator (blue)	<p>Lights up when the high beam is switched on (at the ignition key (18)).</p> <p>f Avoid blinding the oncoming traffic!</p>
43	Front wheel drive (o)	It is on, when the front wheel drive is engaged.
44	Direction indicator control light	It is on, when the direction indicator is operated.
45	Indicator light of engine temperature (red)	<p>It is lit on, when the engine temperature is too high.</p> <p>m The output of the engine drops automatically. (Further travel remains possible). Stop the paver finisher, (set drive lever to neutral position), and let the engine cool at idling speed. Find the cause and if necessary eliminate it (see Chapter „Operating Faults“). Upon cooling down to normal temperature, the engine will work again at full capacity.</p> <p>A The fault is indicated together with the „Error message“ light.</p>
46	Oil pressure indicator for the hydraulic traction drive (red)	<p>Must go out shortly after the engine has been started. Observe warm running. The hydraulic oil is possibly too cold and stiff.</p> <p>m Do not switch on the traction drive when the lamp does not go out (see the section „Malfunctions“).</p> <p>A The lamp goes out when the pressure drops below 2.8 bar = 40 psi.</p>

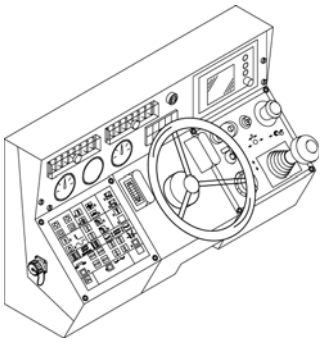

C

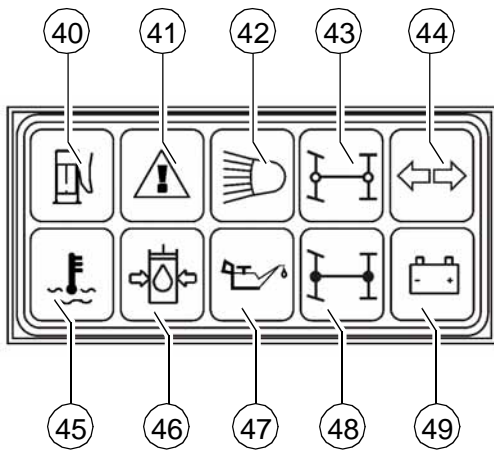
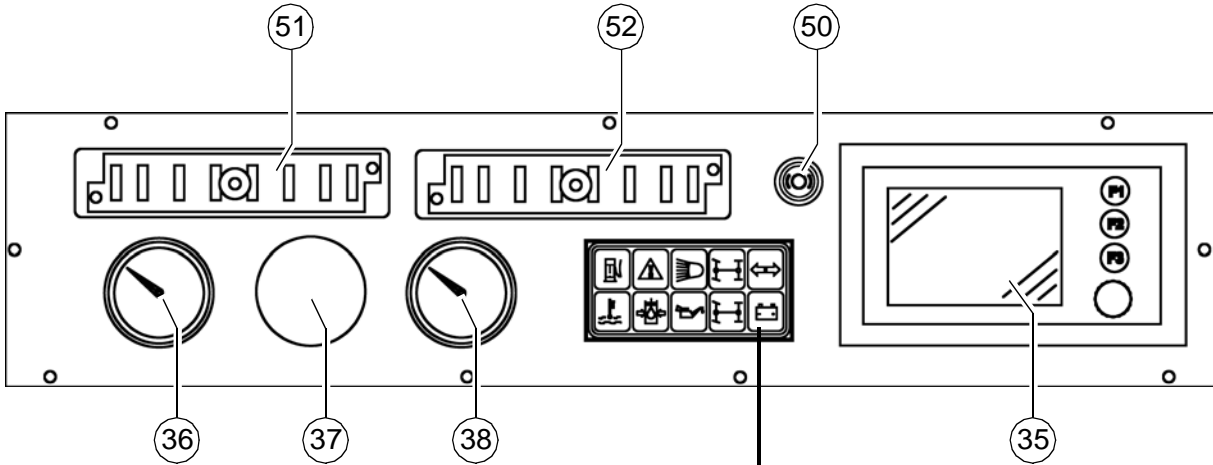

Element3_SPS_Rad_634.bmp/Leuchtmodul_SPS_Kette_635.bmp

Item	Designation	Brief description
47	Oil pressure indicator for the Diesel engine (red)	<p>m It is on, when the oil pressure is too low. Stop the engine again. See the further possible faults in the operating instructions for the engine</p> <p>A The fault is indicated together with the „Error message“ light.</p>
48	Control light differential lock	<p>It is on, when the differential lock is engaged.</p> <p>A In working speed the differential lock is automatically engaged.</p>
49	Battery charge indicator (red)	<p>Must go out after starting when the engine revs up.</p> <p>- Switch off the engine.</p>
50	„Parking brake“ light (red)	<p>It is on when parking brake is active.</p> <p>A When the machine is stopped, the parking brake is automatically engaged.</p> <p>A When the drive lever is moved, the parking brake is automatically released.</p>
51	Fuse box I.	A For assignment of fuse strips, refer to chapter F.
52	Fuse box II.	A For assignment of fuse strips, refer to chapter F.

3 Remote control

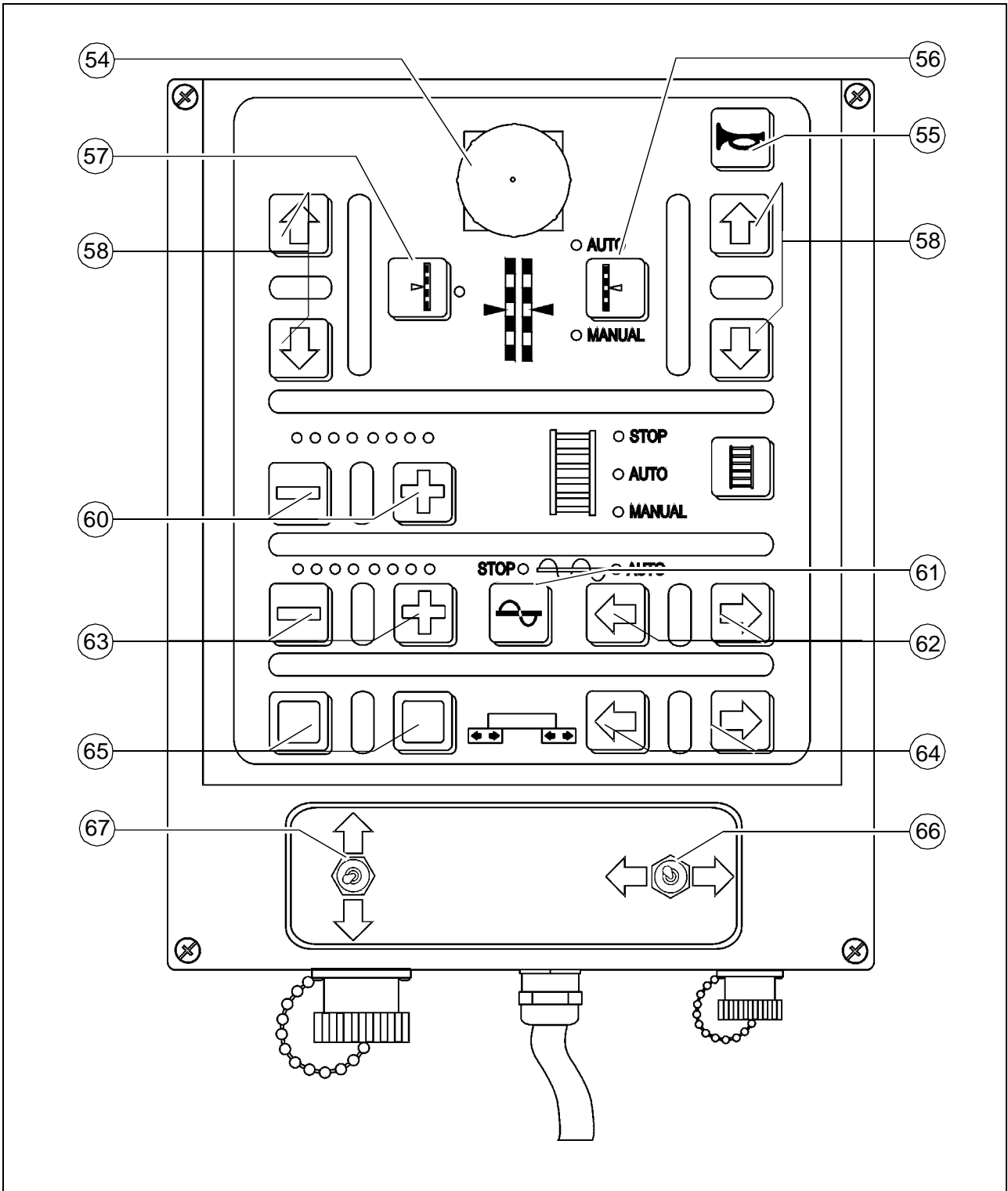

m Warning! Do not isolate while operating by remote control provided with emergency stopping button (0). This will lead to stopping the machine!

Item	Designation	Brief description
54	Emergency stop button (○)	Its function and use are similar to those of the emergency button (7) on the control panel. It is important in such dangerous situations, which cannot be overseen by the driver.
55	Horn	Its function is similar to the button (30) on the control panel.
56	Levelling cylinder	Its function and use are similar to the function of the button (25) on the control panel. - The switch must be set to „manual“ position.
57	The button of adjusting the leveller on the other side.	It allows the operation of the levelling cylinder on the other side of the paver finisher. The display of the other remote control automatically switches to „manual“ position.
58	Buttons of movement directions	Its function is similar to the button (27) on the control panel.
59	Feeder	Its function is similar to the button (32) on the control panel.
60	Capacity of feeder and LED display	Plus / minus buttons for the modification of transport capacity. Indicated by LEDs. The modifications are saved in „auto“ position by button (59).

A If the function (56) was set to position „auto“, when pressing buttons (58) it will revert to „manual“ mode.

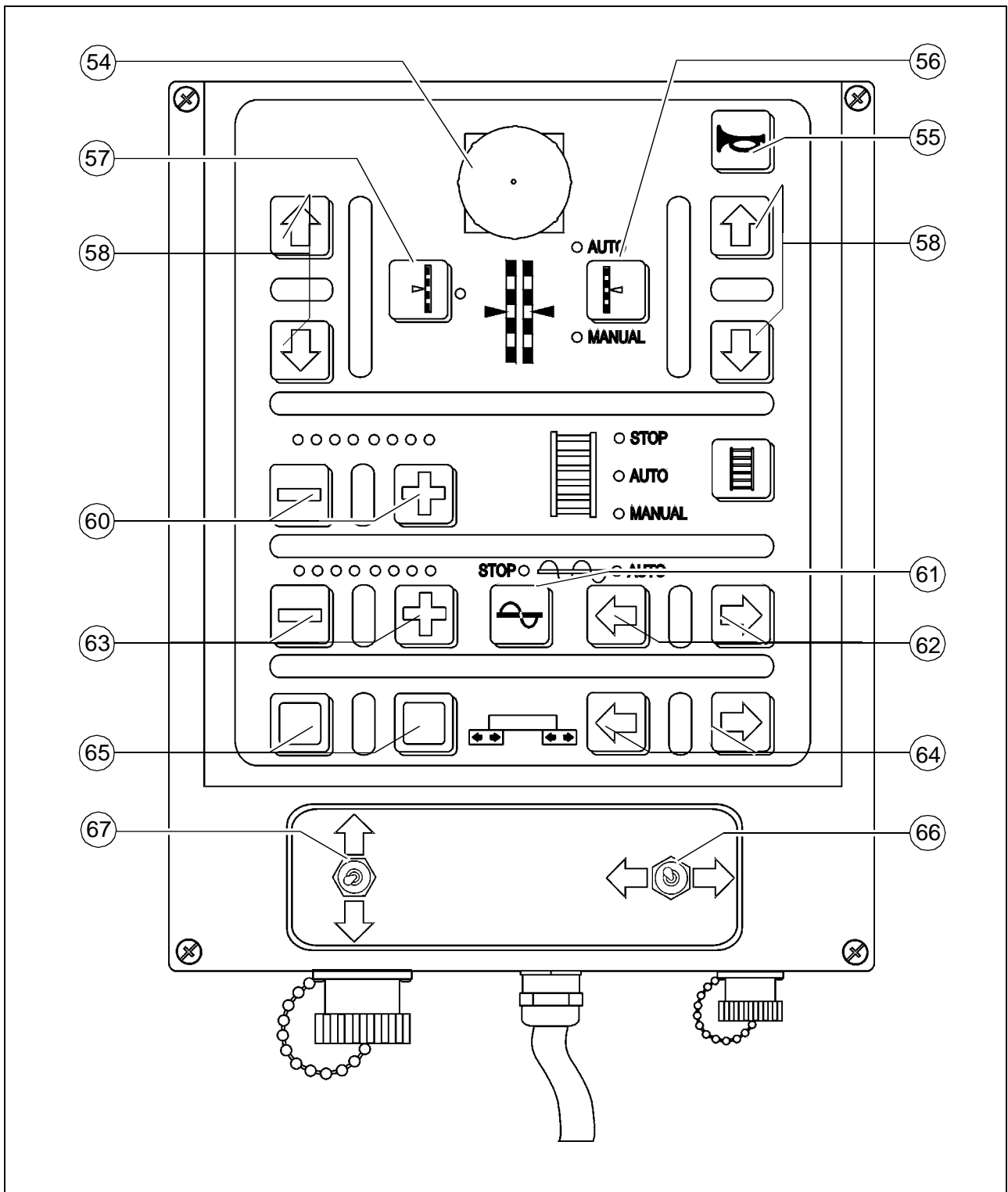

m Warning! Do not isolate while operating by remote control provided with emergency stopping button (0). This will lead to stopping the machine!

Item	Designation	Brief description
61	Auger	Its function is similar to the button (24) on the control panel.
62	Conveying direction of the auger.	For the adjustment of the transport direction of the auger - switch (61) must be set to „auto“.
63	Transport capacity of the auger and LED display	Plus / minus buttons for the modification of transport capacity. Indicated by LEDs. The modifications are saved in „auto“ position by button (61).
64	Screed extension/ retraction	With these buttons the screed can be moved in the directions indicated by the arrows.
65	has no function	
66	Extending / retracting screed (○)	Use these buttons to move the screed in the direction indicated by the arrow.
67	Levelling cylinder left/right (○)	For manually actuating the levelling cylinders when automatic levelling is switched off. This function must be switched to Manual.

- A If the function (61) was set to position „stop“, when pressing buttons (62) it will change to „auto“ mode.
- A Basic setting of the delivery capacity of the auger and the feeder, with respect to the various types of courses (number of LEDs):
- Top layer: 4
 - Binder course 6
 - Load bearing course: 8

Bottom part

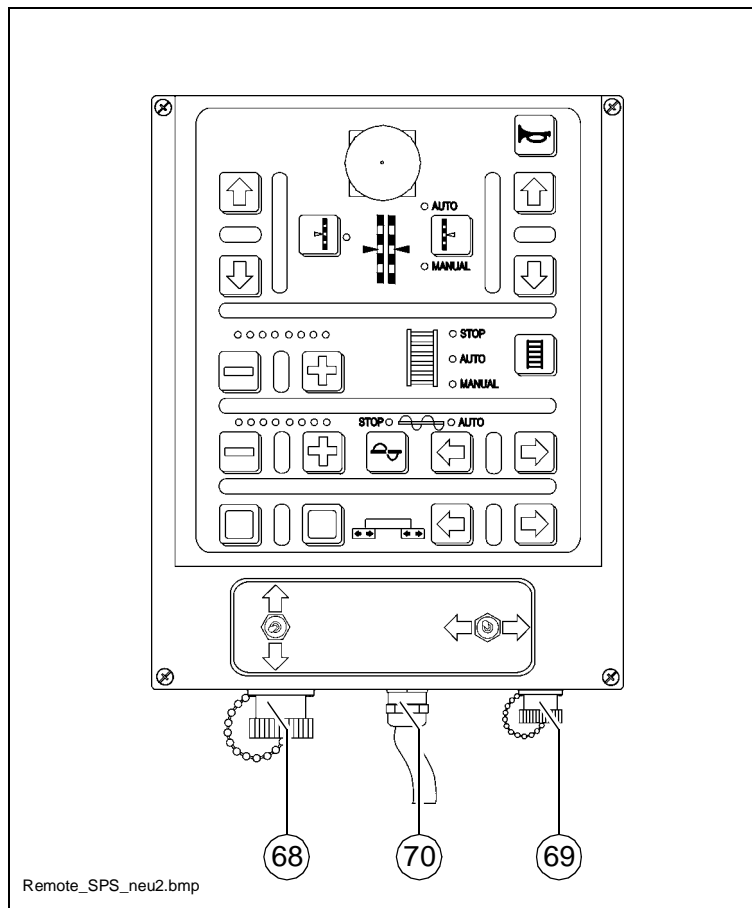

Item	Designation	Brief description
68	Connection to the levelling automatic system	Connect the cable for the grade control unit here.
69	Connection to the end position switch of the auger	Connect the cable for the material limit switch here.
70	Cable for the remote control	Connect to the socket on the screed. (See operating instructions for the screed).

D 2.0 Operation

1 Operation of the input and display terminal

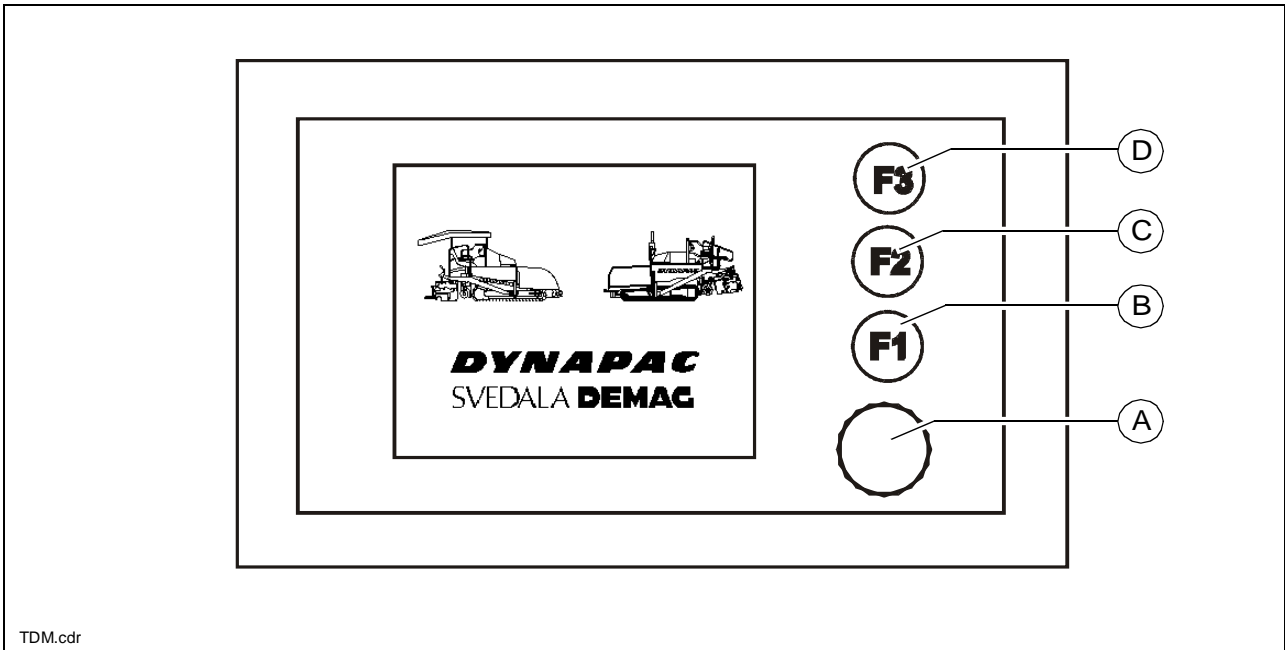

Allocation of the keyboard of the display.

- (A) Encoder (Rotation and pressure):
 - For paging in the menu
 - For selecting various points within one menu
 - For the modification of parameters
 - For confirming the modified parameters
- Buttons (B), (C), (D) F1 - F3:
 - To select the functions displayed on the screen
 - For selecting various points within one menu
 - For the modification of parameters

1.1 Working in the menu

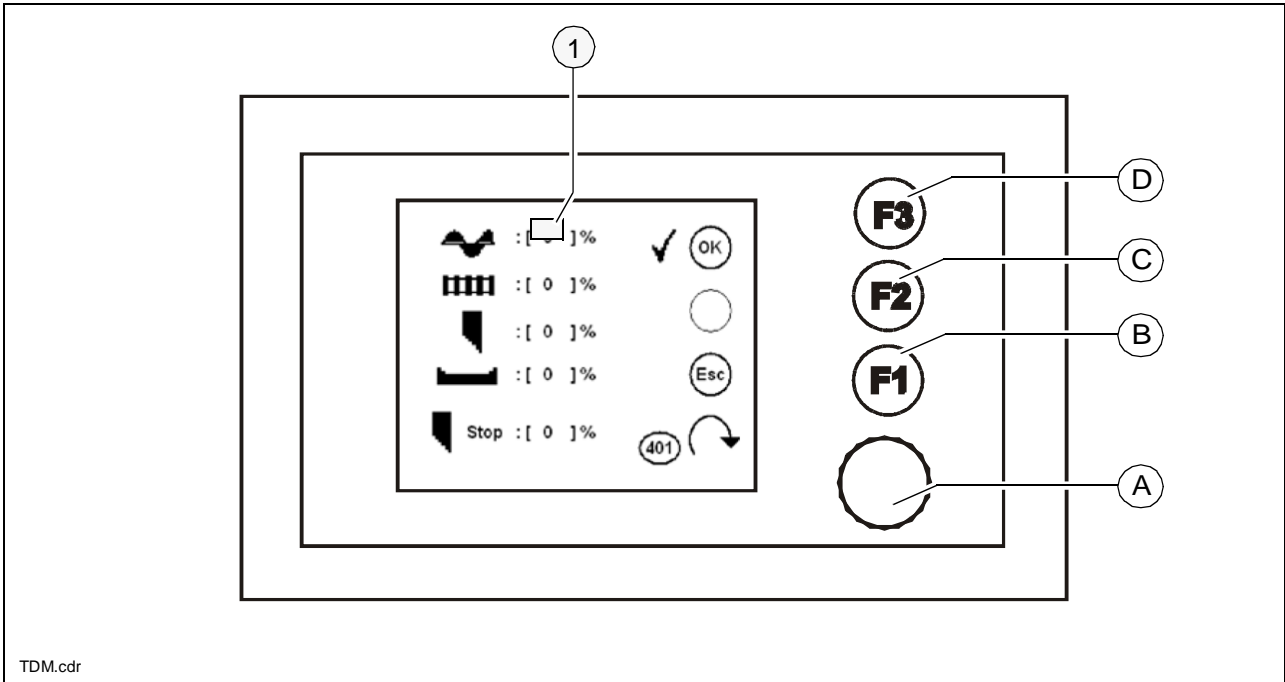

Example: Emergency program (401)

- Rotate (A) Encoder until the selection surface (1) appears.
- Rotate Encoder (A) until the selection surface gets on the menu point required.
- Press (A) Encoder or (B) F2 button to modify the selected menu point.
- Adjust the required value by rotating Encoder (A).
- Press (A) Encoder or (B) F2 button to confirm the set value.

A In the various menus the parameters can be modified directly, without highlighting them with the selection surface!

Menu structure of the setting and display options

The following figure shows the menu structure and operation and it serves the simplification of the procedures in case of various settings and displays.

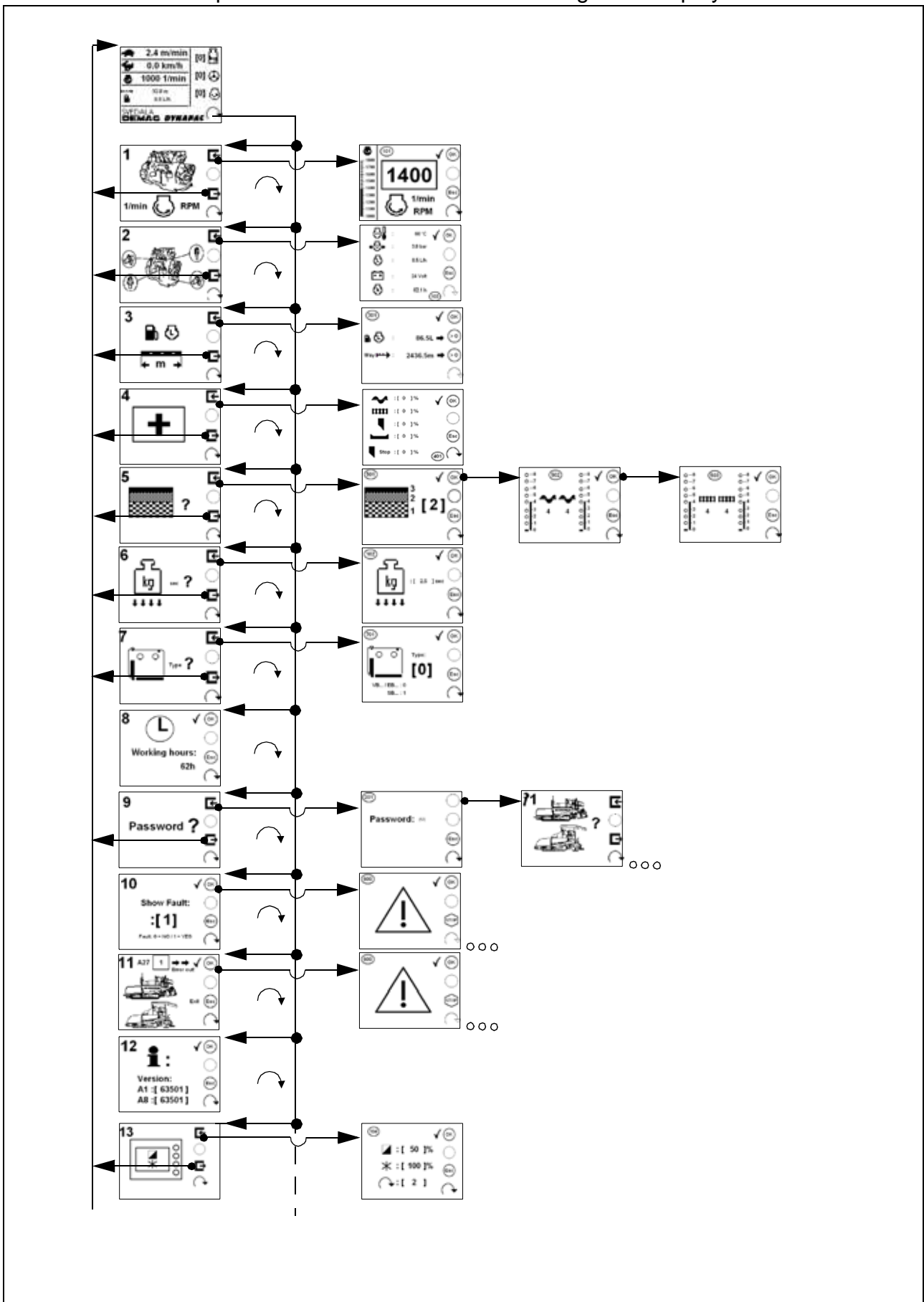

Main menu 00

Display and function menu

- Speed - processing mode (1)
- Speed - Travel (2)
- Engine speed (3)
- Road length meter (4)
- Fuel consumption (5)
- Adjustment possibility „Stopping the screed with pretensioning“ (6)
 - 0=The function is inactive
 - 1=The function is active

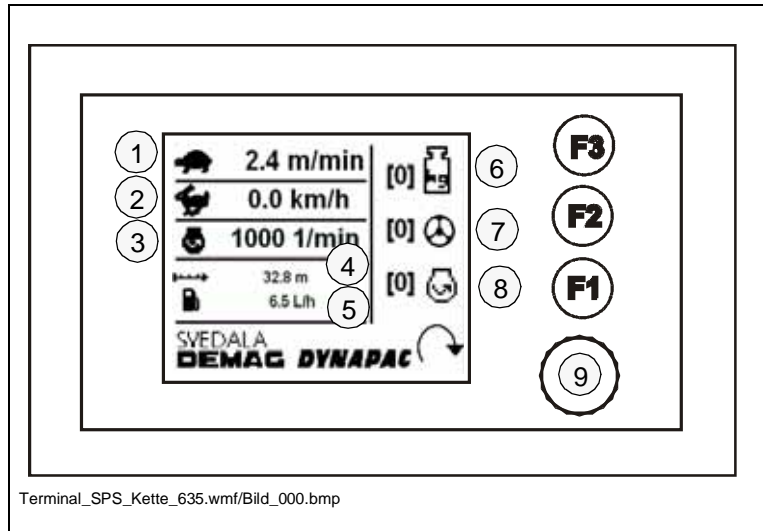

A When the drive lever is in neutral position, the screed retains its position with the pressurization of the appropriate cylinder and so the sinking of the screed into the laid material can be avoided.

- Adjustment possibilities of „Steering Automatic System“ (7)
 - 0=The function is inactive
 - 1=The function is active
- Drive engine in „Eco-mode“ (8)
 - The engine speed is regulated to permanent 1600 rpm.
- Open submenu (101) (9)

A In case of activated steering automatic system the steering potentiometer is OFF. Steering is automatic, by sensing the Ski-string.

Menu 01 - Engine speed

Adjustment menu of engine speed (1)

- Open the submenu: F3).
- Back to the main menu: (F1)

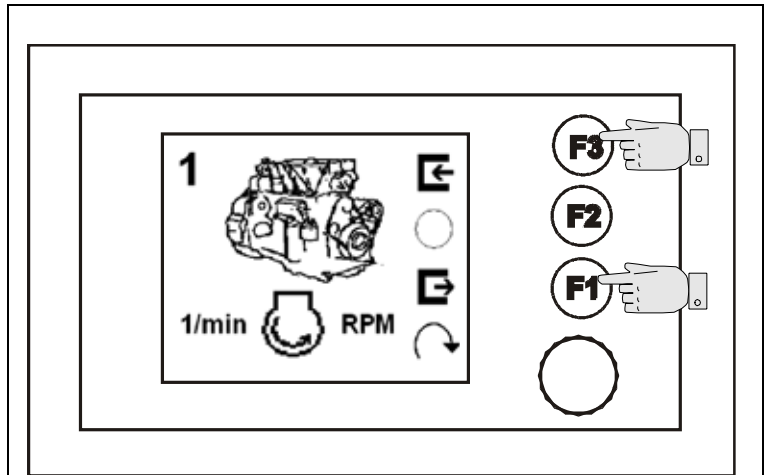

Submenu 101 - Setting the engine speed

- Saving, back to the main menu: (F3)
- Resetting changes, back to the main menu: (F1)

A Setting is performed in steps of 50, the speed of the engine directly follows the adjustments.

A Illustration of engine speed by column diagram (1).

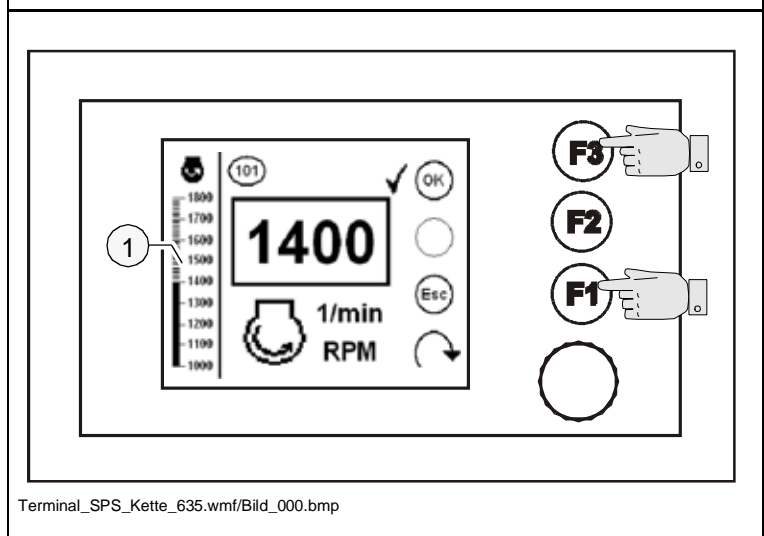

Menu 02 - Measuring value of drive engine

Menu to query the various measuring values of the drive engine.

- Open the submenu: (F3)
- Back to the main menu: (F1)

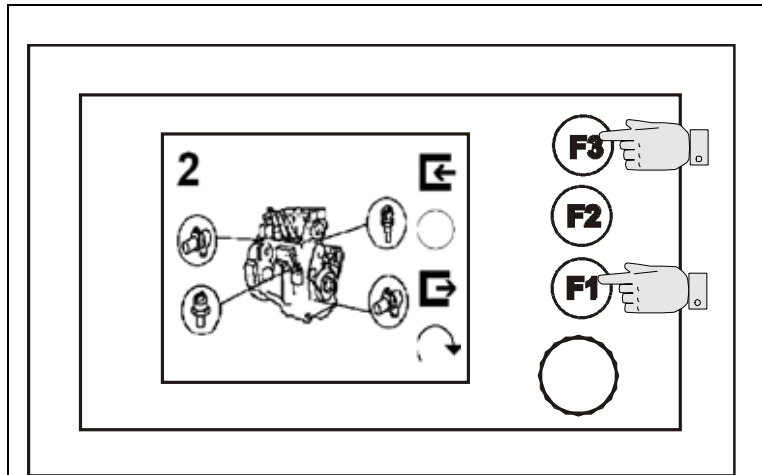

Terminal_SPS_Kette_635.wmf/Bild_000.bmp

Submenu 103 - Display of measuring value Drive engine

Display of the following measuring values:

- Engine temperature (1)
 - Engine oil pressure (2)
 - Fuel consumption (3)
 - Battery voltage (4)
 - Number of engine service hours (5)
- Back to menu 02: (F1), (F3)

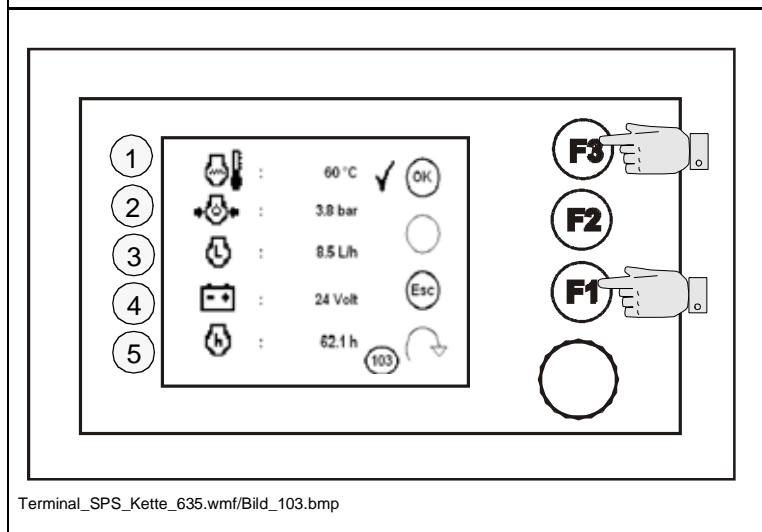

Terminal_SPS_Kette_635.wmf/Bild_103.bmp

Menu 03 - Trip meter and fuel gauge

Menu to query the various operating data

- Open the submenu: (F3)
- Back to the main menu: (F1)

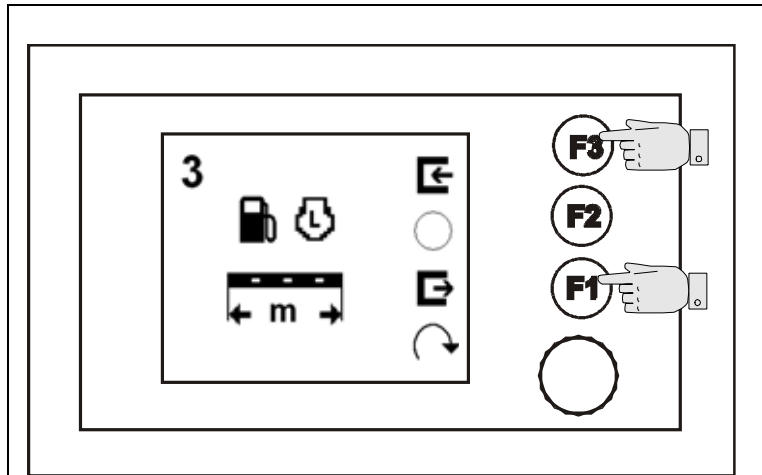

Terminal_SPS_Kette_635.wmf/Bild_003.bmp

Submenu 301 - Road section, fuel consumption display/reset

Display of the following service data:

- Fuel consumed (calculated value) (1)
 - Reset - setting the value to zero, step back Menu 03: (F2)
- Trip covered (2)
 - Reset - setting the value to zero, step back to menu 03 (F1)
- Back to menu 03: (F3)

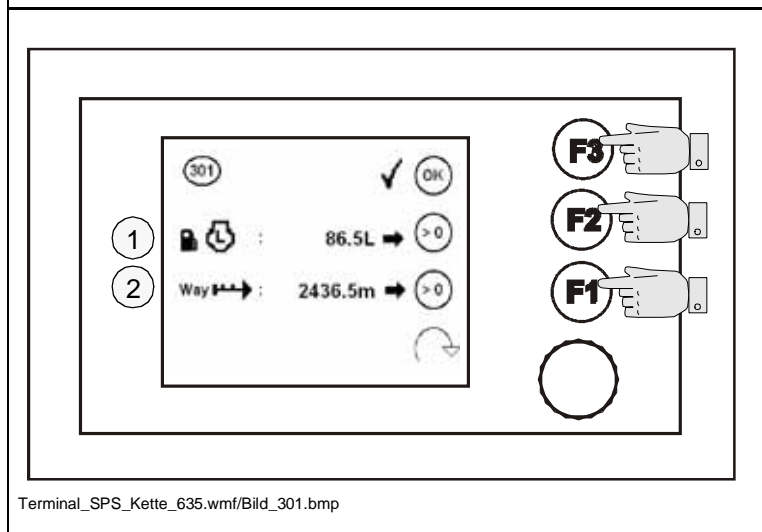

Terminal_SPS_Kette_635.wmf/Bild_301.bmp

Menu 04 - Emergency function / stopping the screed and turning on the tamper

In case of the loss of the specified target value or of the measuring of the actual value (e.g. faulty sensor, transducer), the capacity of the various functions can be set for the automatic operation.

- Open the submenu: (F3)
- Back to the main menu: (F1)

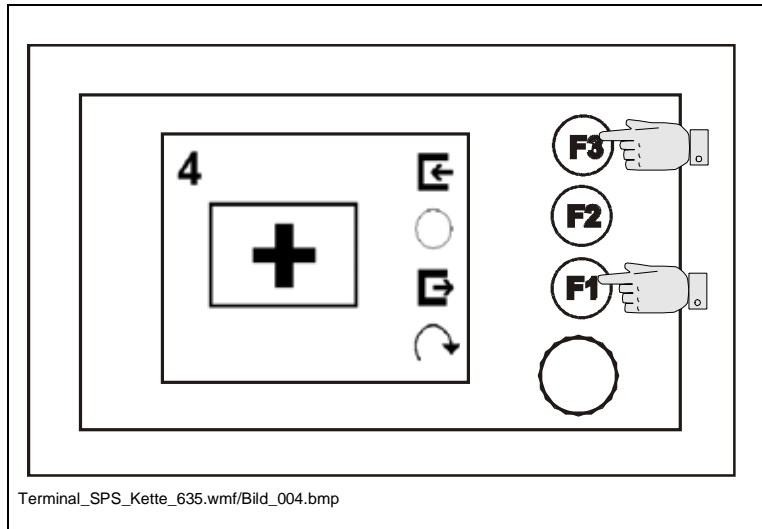

Submenu 401 - Emergency functions adjustment

Capacity change is possible in case of the functions below:

- Auger (1)
- Feeder conveyor (2)
- Tamper (3)
- Vibration (4)
- Tamper stop (5)

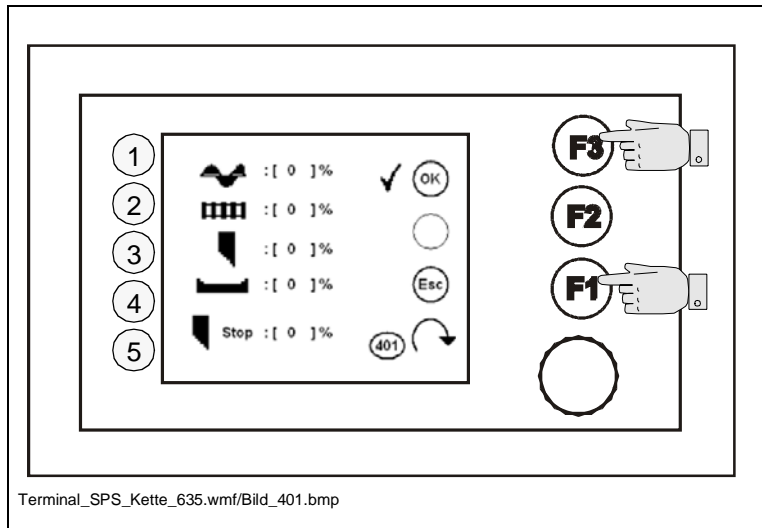

A The current value can be set between 0 and 100%.

A Adjustments of these functions can be carried out, only if a fault has occurred.

- Resetting of parameters, back to menu 04: (F1)
- Saving of set parameters, back to menu 04: (F3)

Menu 05 - Layer thickness

Menu for setting the type of layer to be processed

- Open the submenu: (F3)
- Back to the main menu: (F1)

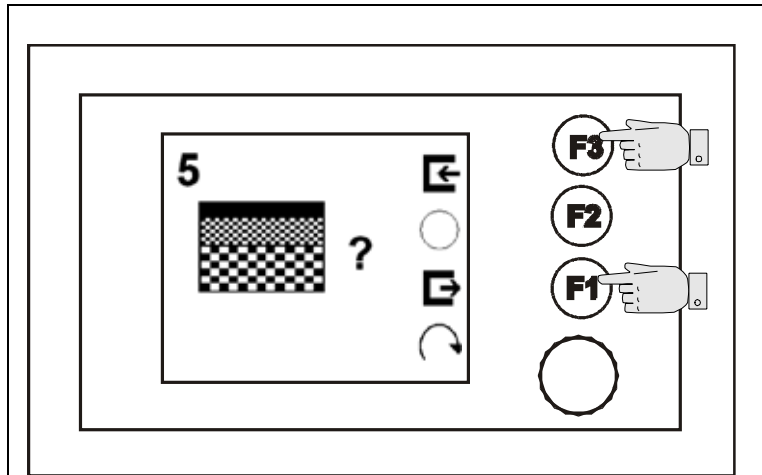

Terminal_SPS_Kette_635.wmf/Bild_005.bmp

Submenu 501 - Preselection of layer thickness

The following types of layers can be selected:

- Top layer: 3 parameters
- Binder course 2 parameters
- Load bearing course: 1 parameter
- Saving, opening of submenu: (F3)
- Resetting changes, back to submenu 05: (F1)

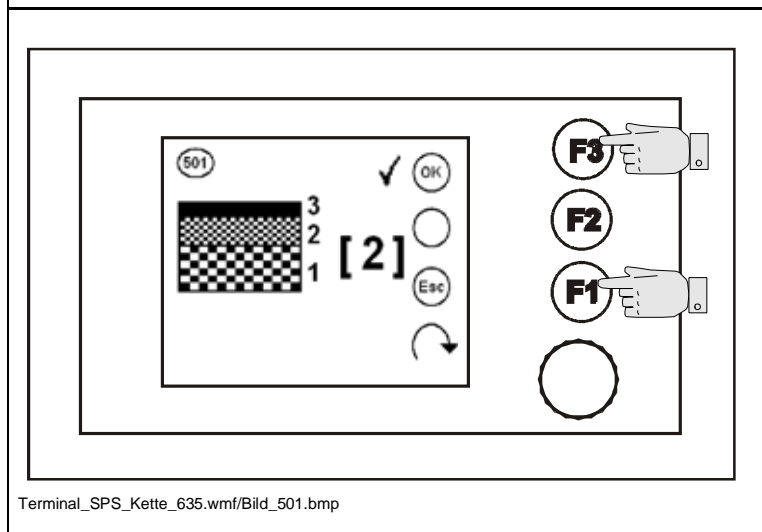

Terminal_SPS_Kette_635.wmf/Bild_501.bmp

A Directly to the following submenu: (F3)

Submenu 502 - Setting the speed of auger

The speed can be set in 8 stages. The actual speed selected for the applicable feeder auger is shown on displays (1) and (2).

Basic settings applicable to the specific layer types:

- Top layer: 4
- Binder course 6
- Load bearing course: 8

- Saving, opening of submenu: (F3)
- Resetting changes, back to submenu 05: (F1)

A Directly to the following submenu: (F3)

A The LED signals of the remote control units change according to the settings made.

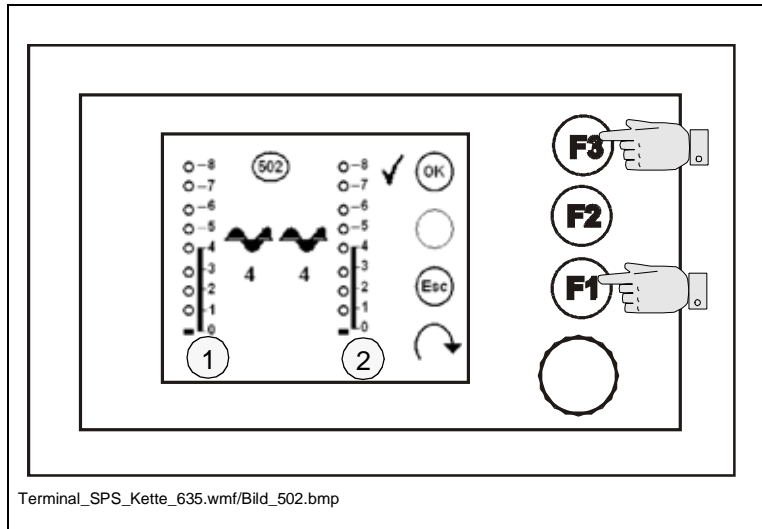

Submenu 503 - Adjustment of the speed of conveyor

The speed can be set in 8 stages. The actual speed selected for the applicable conveyor is shown on display (1) and (2).

Basic settings applicable to the specific layer types:

- Top layer: 4
- Binder course 6
- Load bearing course: 8

- Saving, back to submenu 05: (F3).
- Resetting changes, back to submenu 05: (F1).

A The LED signals of the remote control units change according to the settings made.

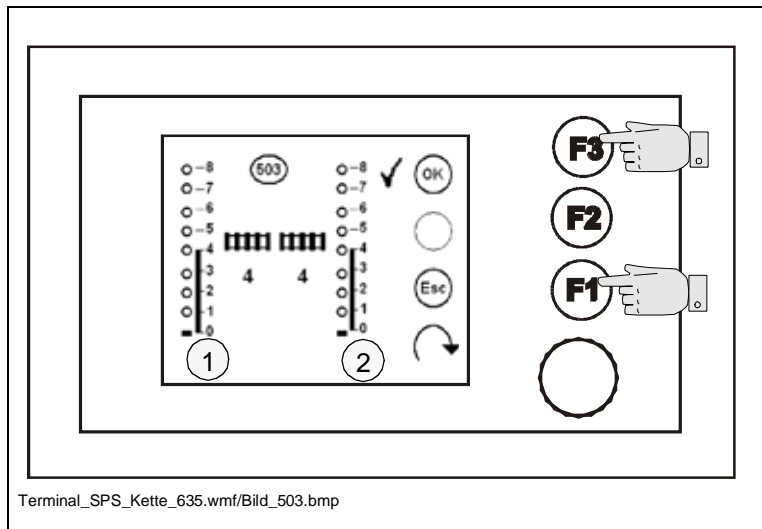

Menu 06 - Screed charging

Menu to set the starting load

- Open the submenu: (F3)
- Back to the main menu: (F1)

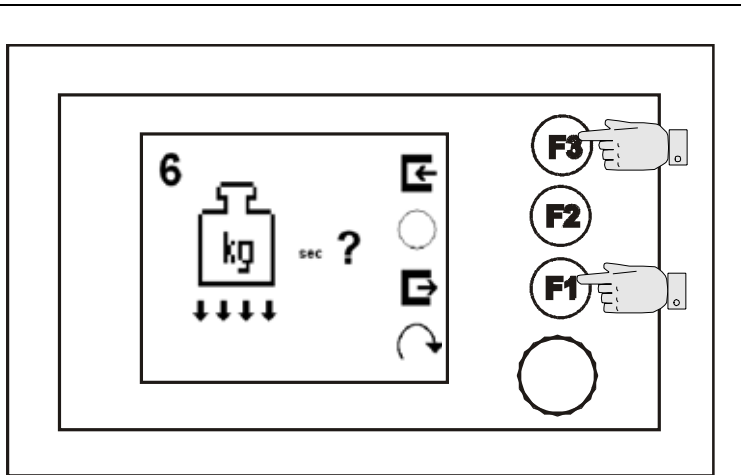

Terminal_SPS_Kette_635.wmf/Bild_006.bmp

Submenu 102 - Starting load setting

Setting the duration of starting load

- Saving, back to submenu 06: (F3)
- Resetting changes, back to menu 06: (F1)

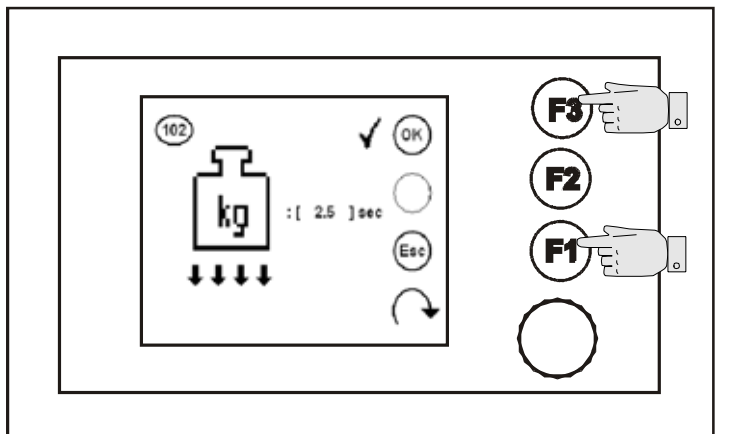

Terminal_SPS_Kette_635.wmf/Bild_102.bmp

Menu 07 - Scred type

Menu for adjusting the screed type

- Open the submenu: (F3)
- Back to the main menu: (F1)

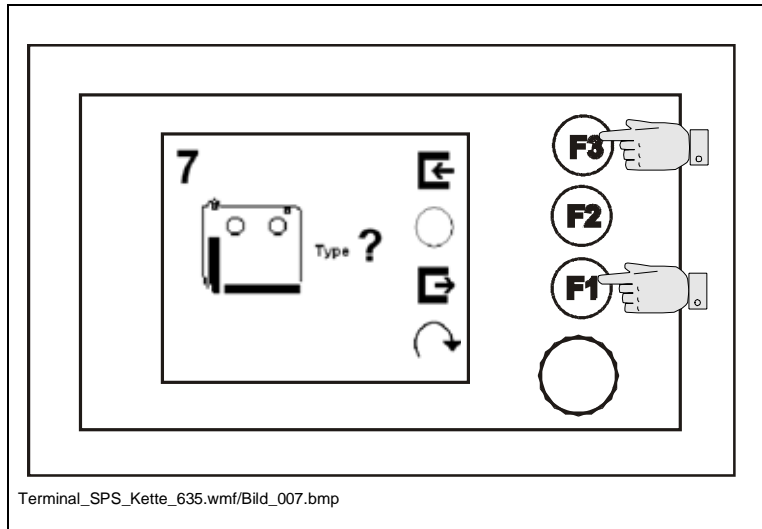

Submenu 701 - Setting the screed type

The following screed types can be set:

- VB/EB-screed type: 0 parameter
- SB-screed: 1 parameter
- Saving, back to submenu 07: (F3)
- Resetting changes, back to menu 07: (F1)

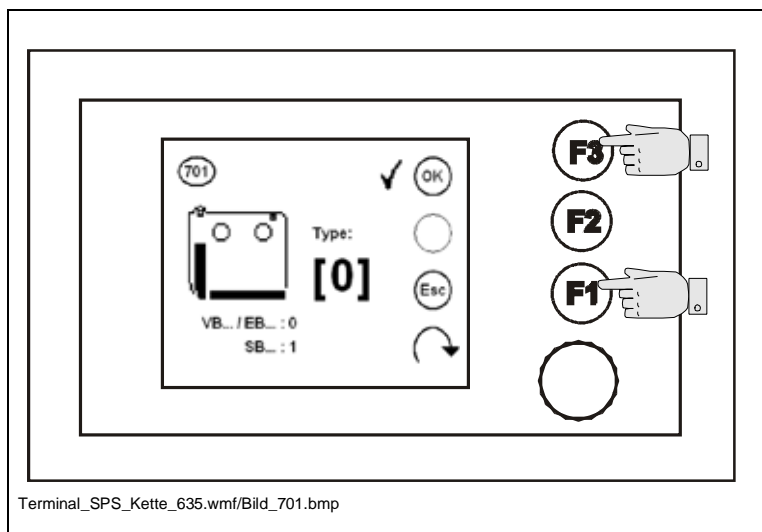

Menu 08 - Service hour meter

Menu to query the service hours

- Back to the main menu: (F1) or (F3)

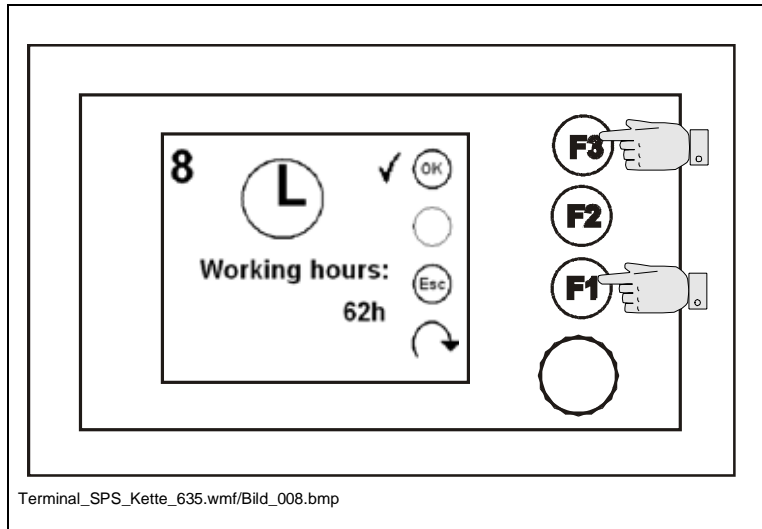

Menu 09 - Service

Password protected menu to perform the various service settings

- Password prompt opening: (F3)
- Back to the main menu: (F1)

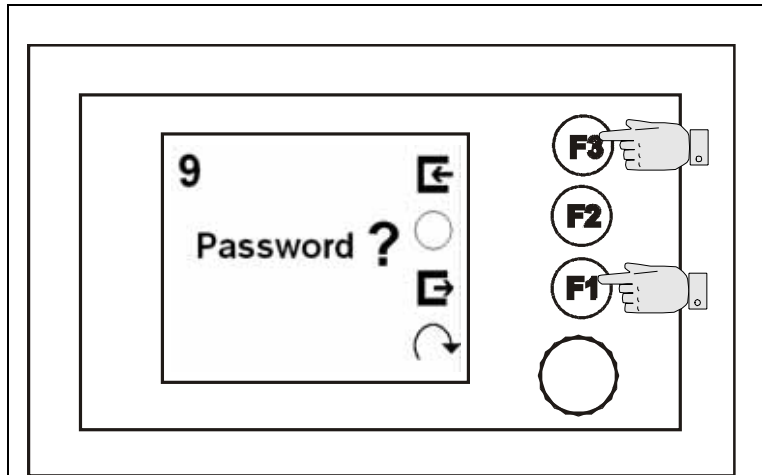

Terminal_SPS_Kette_635.wmf/Bild_009.bmp

Submenu 201 - Password prompt

Enter password:

- The password can be confirmed by pressing the Encoder
- Back to menu 09: (F1)

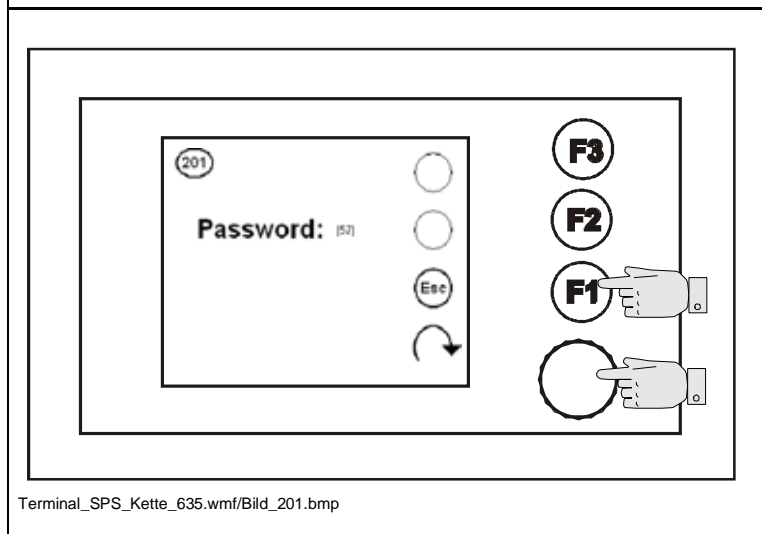

Terminal_SPS_Kette_635.wmf/Bild_201.bmp

Menu 10 - Error memory

Menu for the repeated query of error messages

- Display (0): There is no error message
- Display (1): Fault message can be displayed
- Error message query: (F3)
- Back to the main menu: (F1)

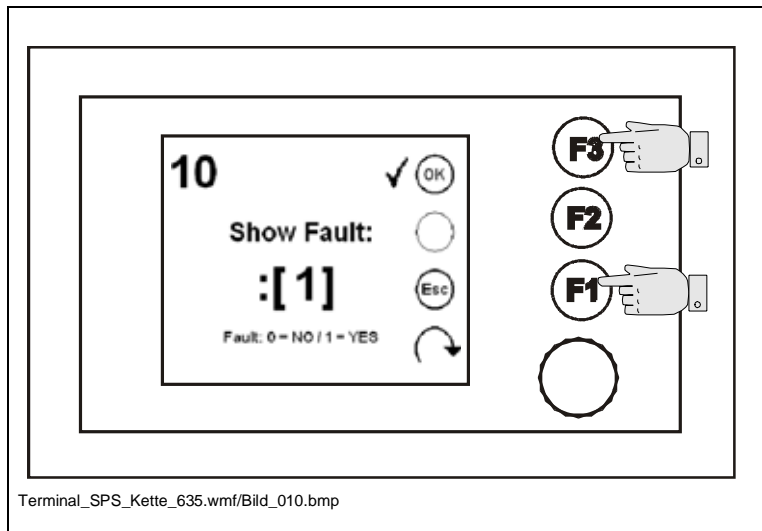

Error message display:

A In case of error messages first always the message (600) „Attention“ is displayed

- Error message display: (F3)
- Back to menu 10: (F1)

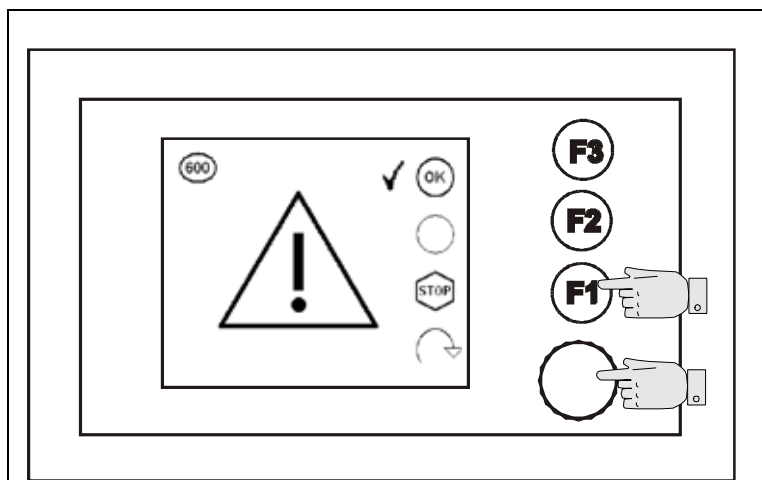

Error display

- Calling down the next fault: (F3)

A If additional faults have also occurred, again the message „Attention“ will be displayed.

A When the last error message was read, the system returns to the main menu.

A All the error messages can be identified in the chapter „Error messages of Terminal“.

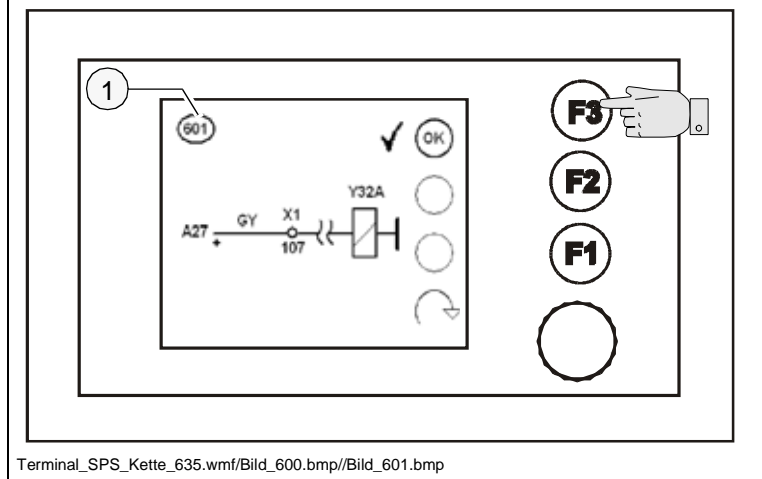

A In case you use the help of Technical Support for your machine, always specify the number of the error message (1).

Menu 11 - Error memory Computer of machine operation

Menu for the repeated query of error messages sent by the computer of machine operation

- Display (0): There is no error message
- Display (1): Fault message can be displayed
- Retrieval of error message: (F3)
- Back to the main menu: (F1)

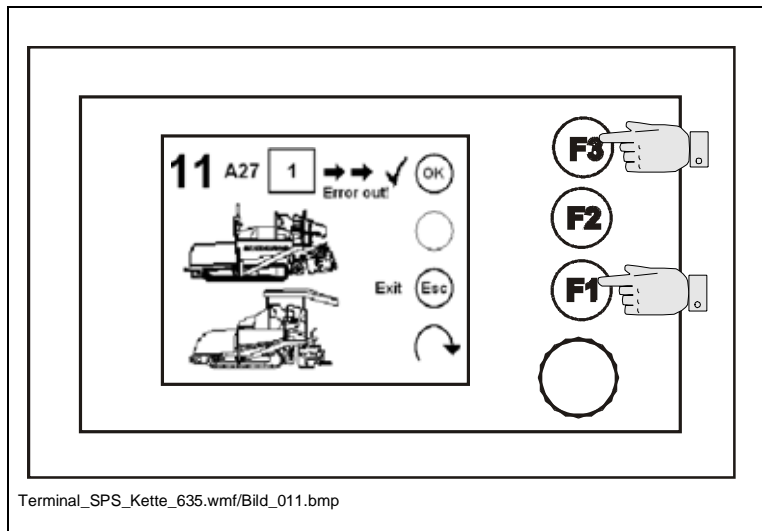

Error message display:

A In case of error messages first always the message (600) „Attention“ is displayed

- Error message display: (F3)
- Back to menu 10: (F1)

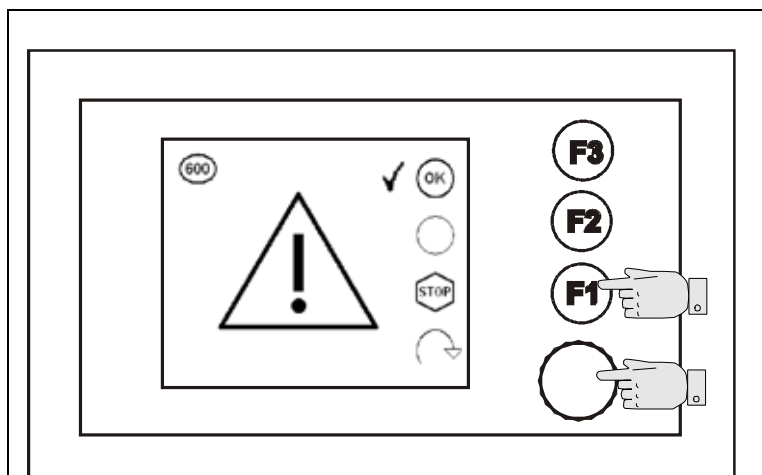

Error display

- Calling down the next fault: (F3)

A If additional faults have also occurred, again the message „Attention“ will be displayed.

A When the last error message was read, the system returns to the main menu.

A All the error messages can be identified in the chapter „Error messages of Terminal“.

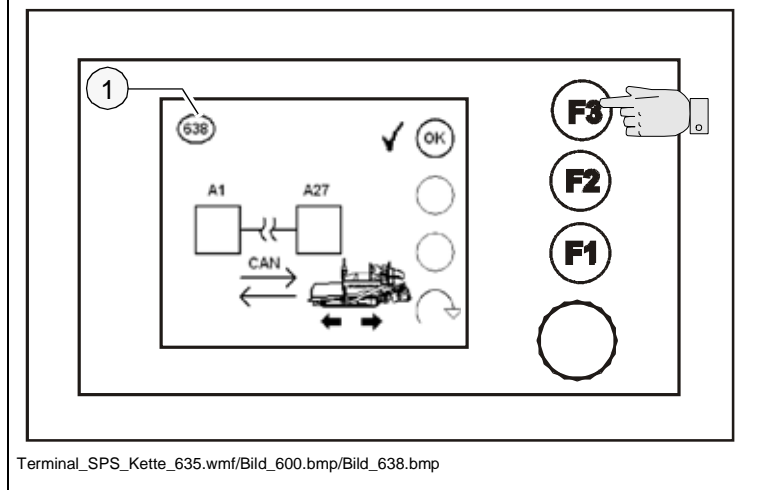

A In case you use the help of Technical Support for your machine, always specify the number of the error message (1).

Menu 12 - Program version

Menu to query the version number of the installed program

A

In case you use the help of Technical Support for your machine, always specify the version number of the program.

- Back to the main menu:
(F1) or (F3)

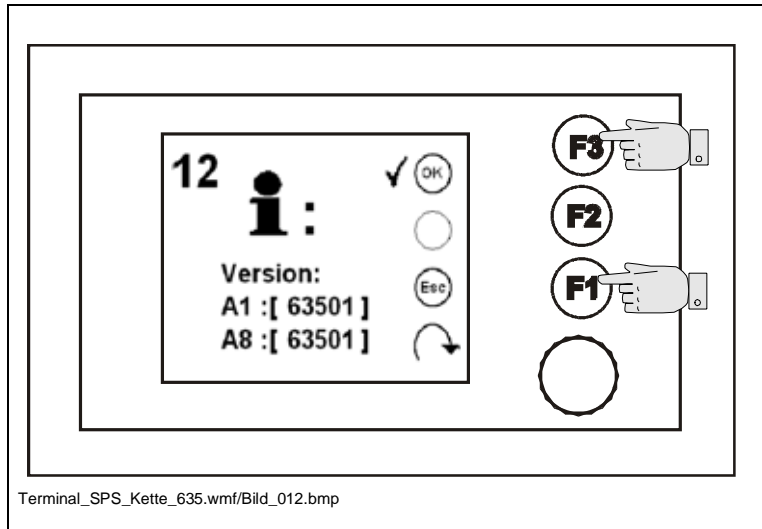

Menu 13 - Terminal settings

Menu for the various settings of the terminal

- Open the submenu: (F3)
- Back to the main menu: (F1)

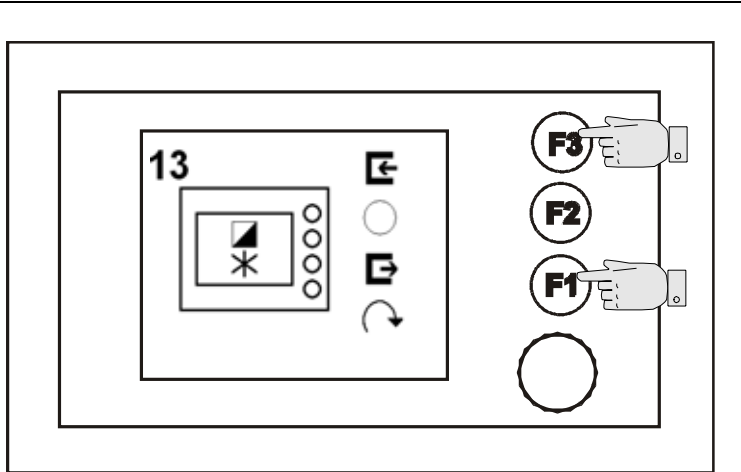

Terminal_SPS_Kette_635.wmf/Bild_013.bmp

Submenu 104 - Terminal settings

Setting of Contrast (1)
brilliance of display (2) and
the sensitivity of Encoder (3)

- Saving, back to submenu 13: (F3)
- Resetting changes, back to submenu 13: (F1)

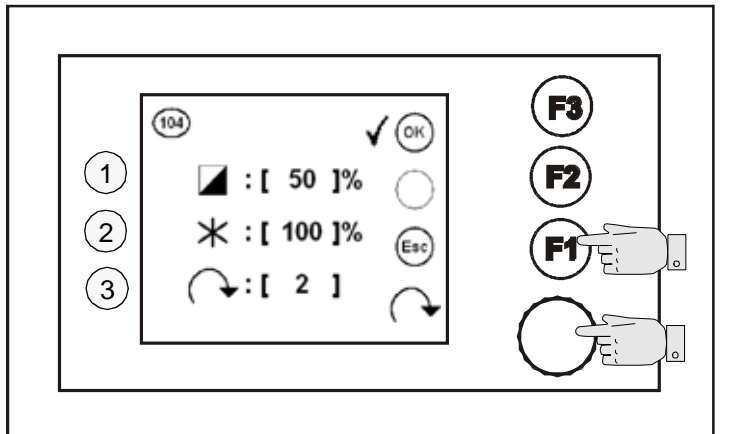

Terminal_SPS_Kette_635.wmf/Bild_104.bmp

1.2 Further messages on the display

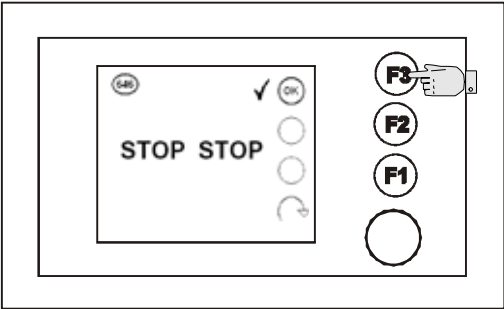
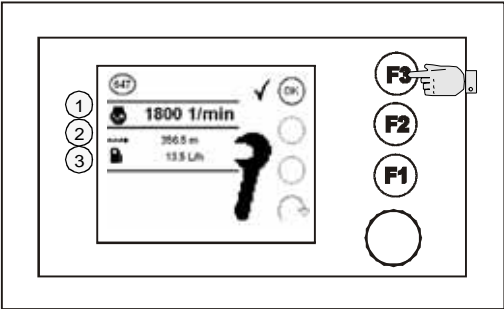
Display No. / report	Display
<p>message 646 Emergency stop button depressed</p> <ul style="list-style-type: none"> - Back to the previous menu: (F3) 	
<p>message 647 Adjustment mode</p> <p>Displays:</p> <ul style="list-style-type: none"> - Engine speed (1) - Trip covered (2) - Fuel consumed (calculated value) (3) - Back to the previous menu: (F3) 	

2 Terminal error messages

A Each error message is assigned a number. If you use the help of the Technical Support for your machine, please, provide this number and all information included in the error message.

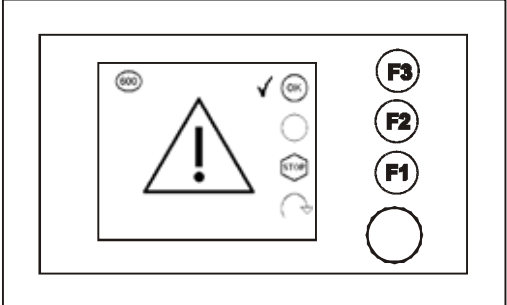
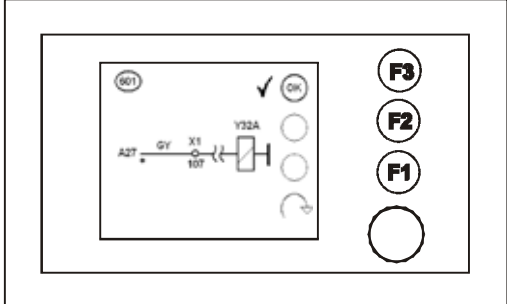
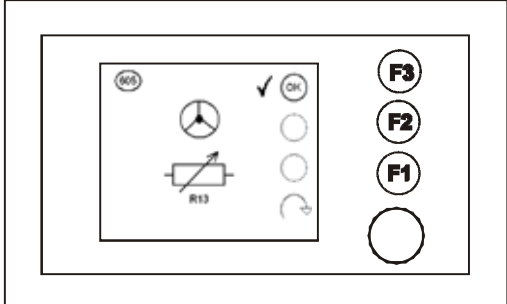
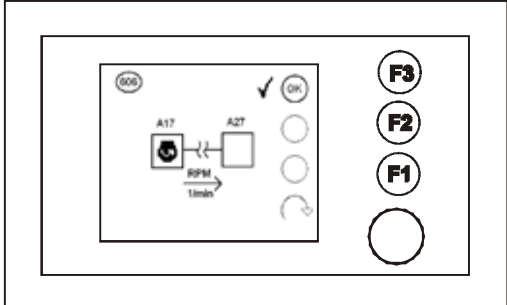
Fault No. / report	Display
<p>600. error message General fault display</p>	
<p>601. error message Broken wire Pump of travel automatic / drive lever</p>	
<p>605. error message - Faulty steering potentiometer</p>	
<p>606. error message - Communication interrupted Drive motor of travel automatic unit</p>	

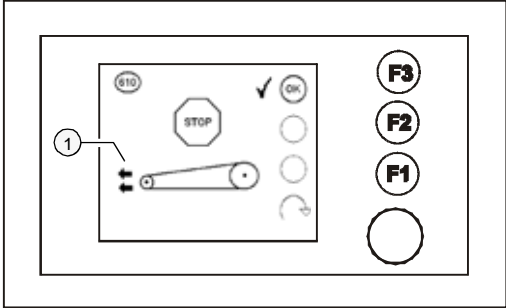
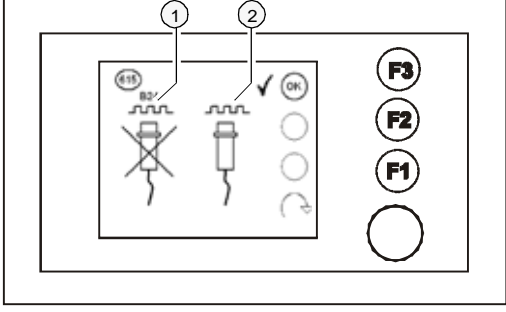
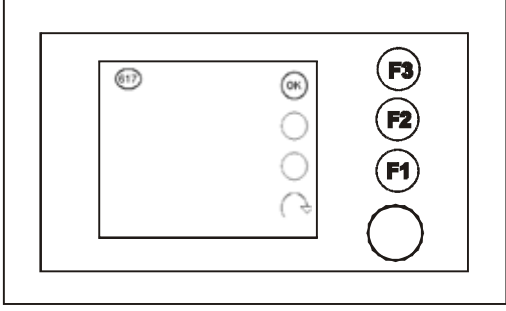
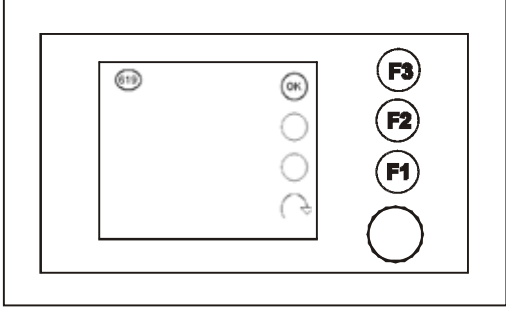
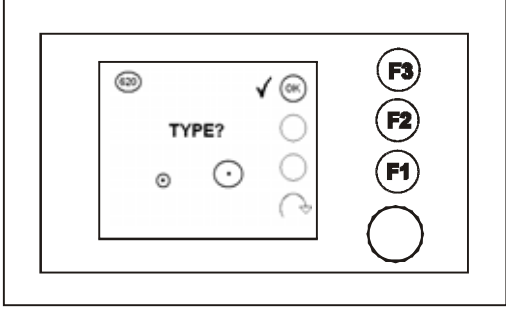
Fault No. / report	Display
<p>610. error message</p> <ul style="list-style-type: none"> - „Drive lever forward“ locked <p>Variable:</p> <ul style="list-style-type: none"> - Drive / steering direction (1) 	
<p>615. error message</p> <ul style="list-style-type: none"> - Sensor of running gear faulty <p>Variable:</p> <ul style="list-style-type: none"> - LH-side sensor (1) - RH-side sensor (2) 	
<p>617. error message</p> <ul style="list-style-type: none"> - Broken line - drive lever pump control 	
<p>619. error message</p> <ul style="list-style-type: none"> - Short circuit / line fault - drive lever potentiometer / drive lever - microswitch (opposite switch) 	
<p>620. error message</p> <ul style="list-style-type: none"> - The type of paver finisher is not set in the service software 	

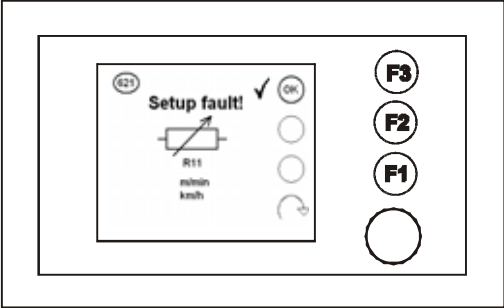
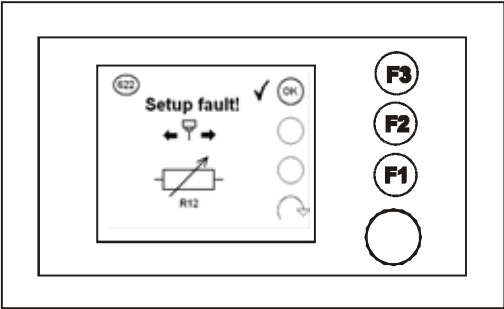
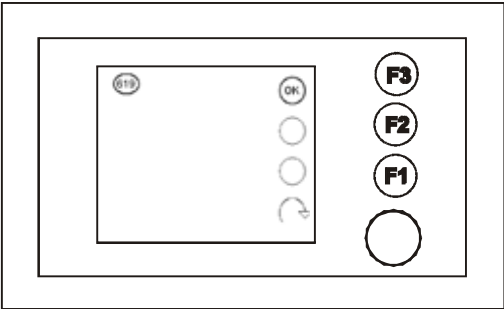
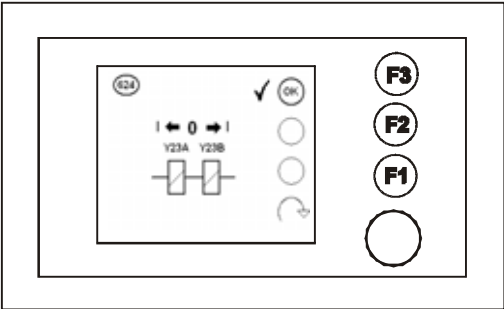
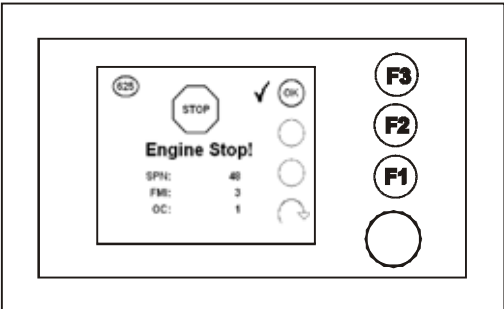
Fault No. / report	Display
<p>621. error message</p> <ul style="list-style-type: none"> - Setup fault of travel speed potentiometer in the service software. 	
<p>622. error message</p> <ul style="list-style-type: none"> - Drive lever potentiometer setup-fault in the service software. 	
<p>623. error message</p> <ul style="list-style-type: none"> - Short circuit / line fault - drive lever microswitch forward / reverse (parallel switch) 	
<p>624. error message</p> <ul style="list-style-type: none"> - Pump current zero position (dead band) not specified in the service software. 	
<p>625. error message</p> <p>Fault with the engine position SPN = part concerned FMI = type of fault OC = frequency of repetition A see chapter „Fault codes of drive engine“.</p>	

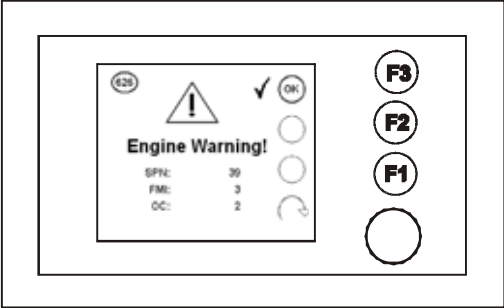
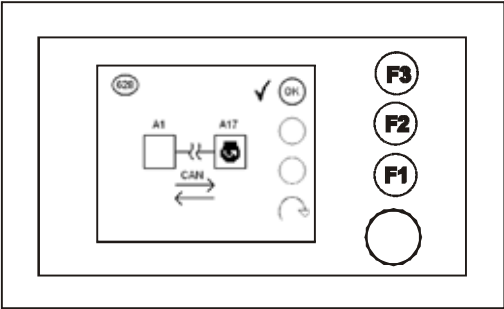
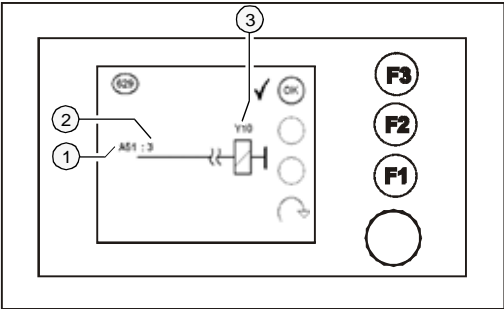
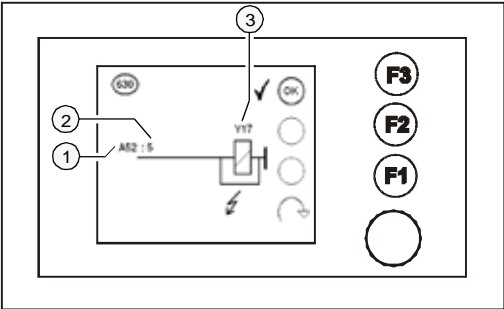
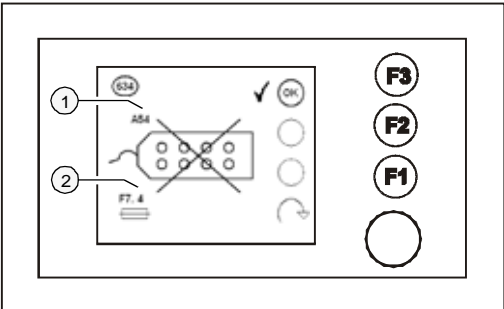
Fault No. / report	Display
<p>626. error message</p> <ul style="list-style-type: none"> - Warning signal of traction engine - SPN = part concerned - FMI = type of fault - OC = frequency of repetition <p>A see chapter „Fault codes of traction engine“.</p>	
<p>628. error message</p> <ul style="list-style-type: none"> - Communication interrupted Master drive engine 	
<p>629. error message</p> <ul style="list-style-type: none"> - Slave output wire broken <p>Variable:</p> <ul style="list-style-type: none"> - Slave No. (1) - Slave-output (2) - Controlled element (3) 	
<p>630. error message</p> <ul style="list-style-type: none"> - Slave output short circuit <p>Variable:</p> <ul style="list-style-type: none"> - Slave No. (1) - Slave-output (2) - Controlled element (3) 	
<p>634. error message</p> <ul style="list-style-type: none"> - Slave fault <p>Variable:</p> <ul style="list-style-type: none"> - Slave No. (1) - Fuse (2) 	

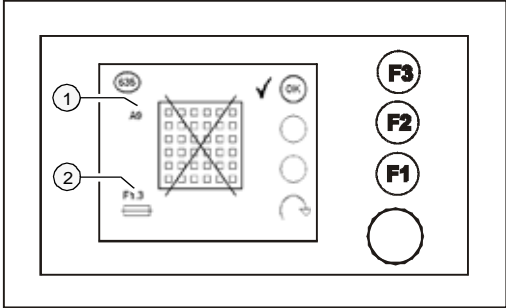
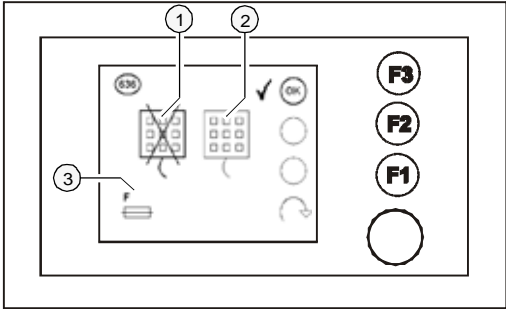
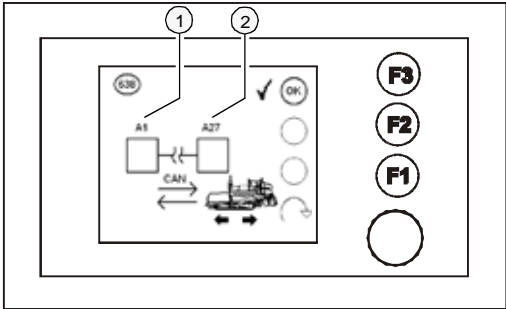
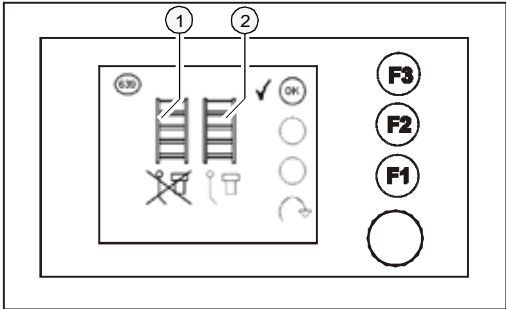
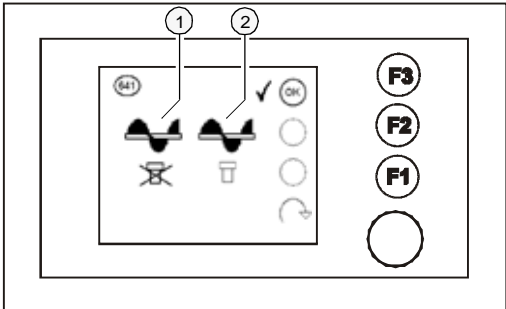
Fault No. / report	Display
<p>635. error message</p> <ul style="list-style-type: none"> - Keyboard fault / Keyboard fuse faulty 	
<p>636. error message</p> <ul style="list-style-type: none"> - Remote control fault / Keyboard fuse faulty <p>Variable:</p> <ul style="list-style-type: none"> - LH-side remote control (1) - RH-side remote control (2) - Remote control fuse (3) 	
<p>638. error message</p> <ul style="list-style-type: none"> - Communication interrupted Master drive automatic system <p>A Observe the rules described in Chapter „Instructions for fault messages“.</p>	
<p>639. error message</p> <ul style="list-style-type: none"> - Conveyor limit switch faulty <p>Variable:</p> <ul style="list-style-type: none"> - LH-side limit switch (1) - RH-side limit switch (2) 	
<p>641. error message</p> <ul style="list-style-type: none"> - Auger limit switch faulty <p>Variable:</p> <ul style="list-style-type: none"> - LH-side limit switch (1) - RH-side limit switch (2) 	

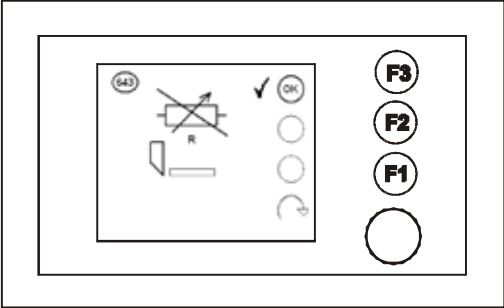
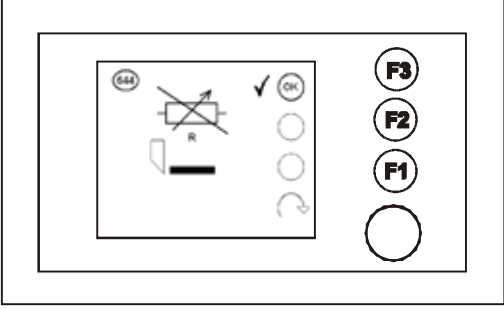
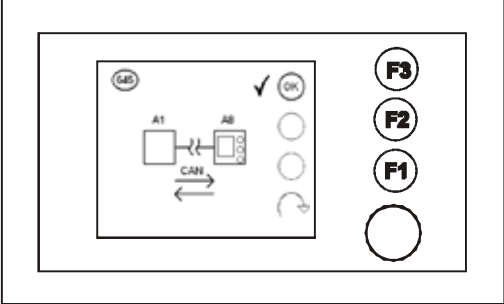
Fault No. / report	Display
<p>643. error message - Tamper target value potentiometer faulty</p>	
<p>644. error message - Vibrator target value potentiometer faulty</p>	
<p>645. error message - Communication interrupted Master display</p>	

2.1 Instructions related to error messages

638. error message

Communication interrupted
Master drive automatic system.

A First check if the fuse F5.1 is good.

If the cause of the interrupted data link is not the fuse, the Diesel engine can be started.

- Switch on button (1) (LED comes on)
- Press start button (2).

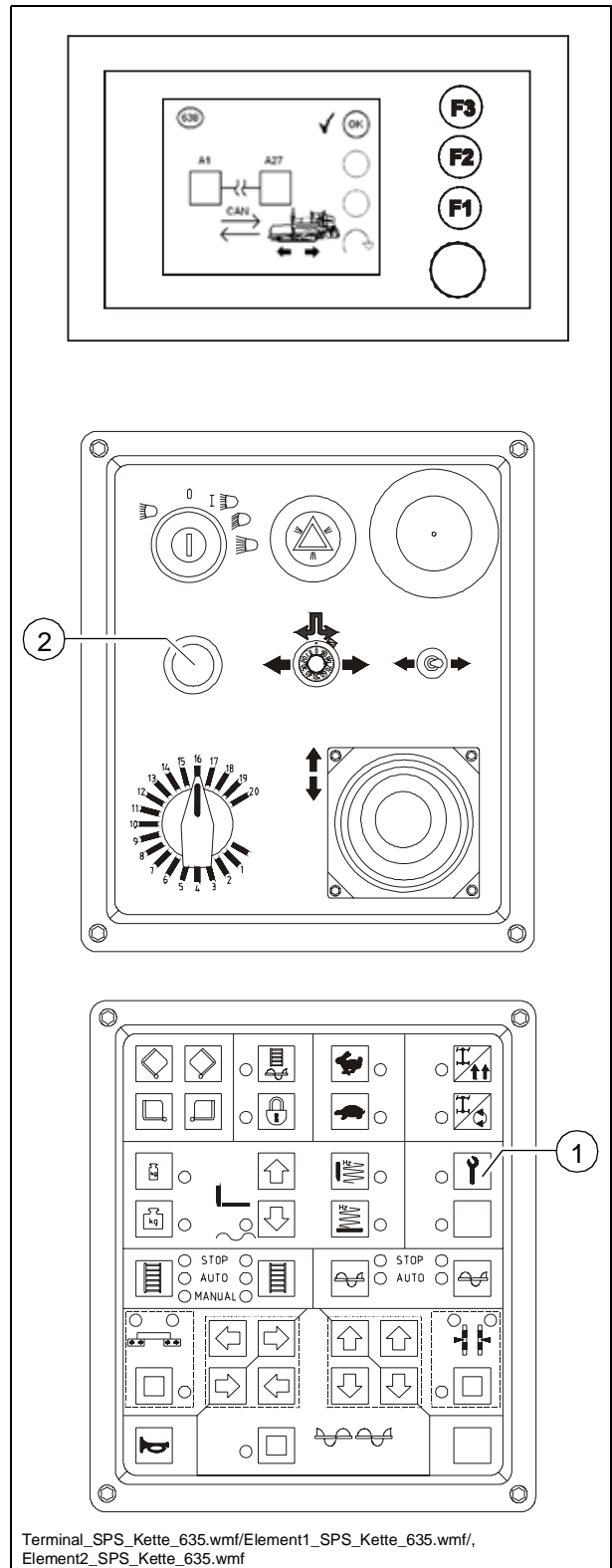

2.2 Fault codes of the traction engine.

If a fault occurs in the traction engine, this is indicated by the specific signal lamp (1) and simultaneously an explanation appears on the display.

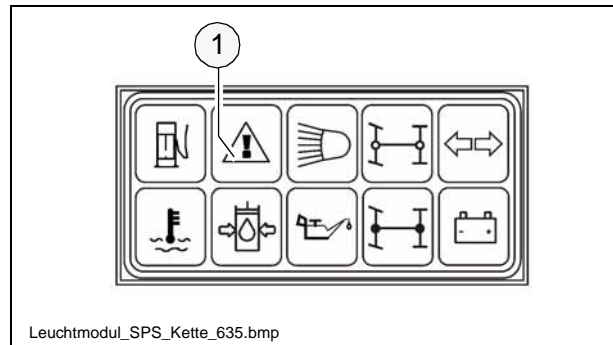

The error message displayed simultaneously includes several error codes, the decoding of which clearly defines the fault.

- The display „ENGINE WARNING“ (2) indicates that a fault has occurred in the traction engine. The machine can be further operated temporarily. In order to prevent further damage, the error should however be rectified as soon as possible.
- „STOP ENGINE!“ (Stop Engine!) display (3) the traction engine is failed to such an extent that the engine immediately stops automatically, or it has to be stopped to avoid further damage.

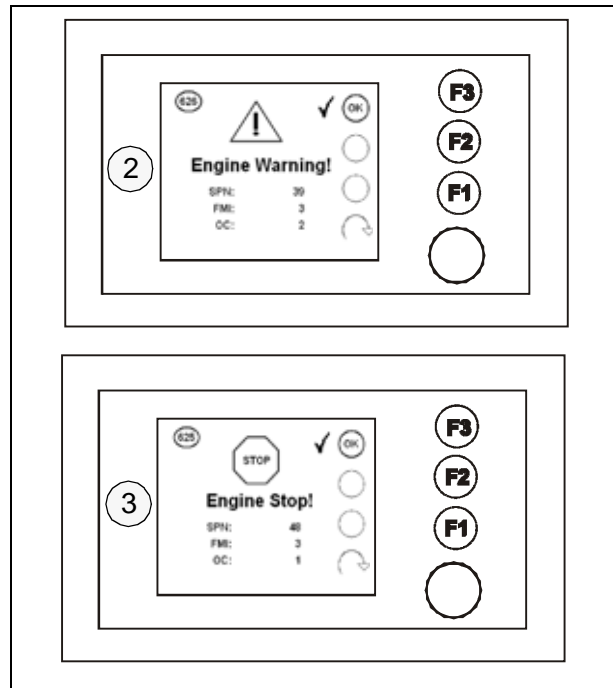

Example:

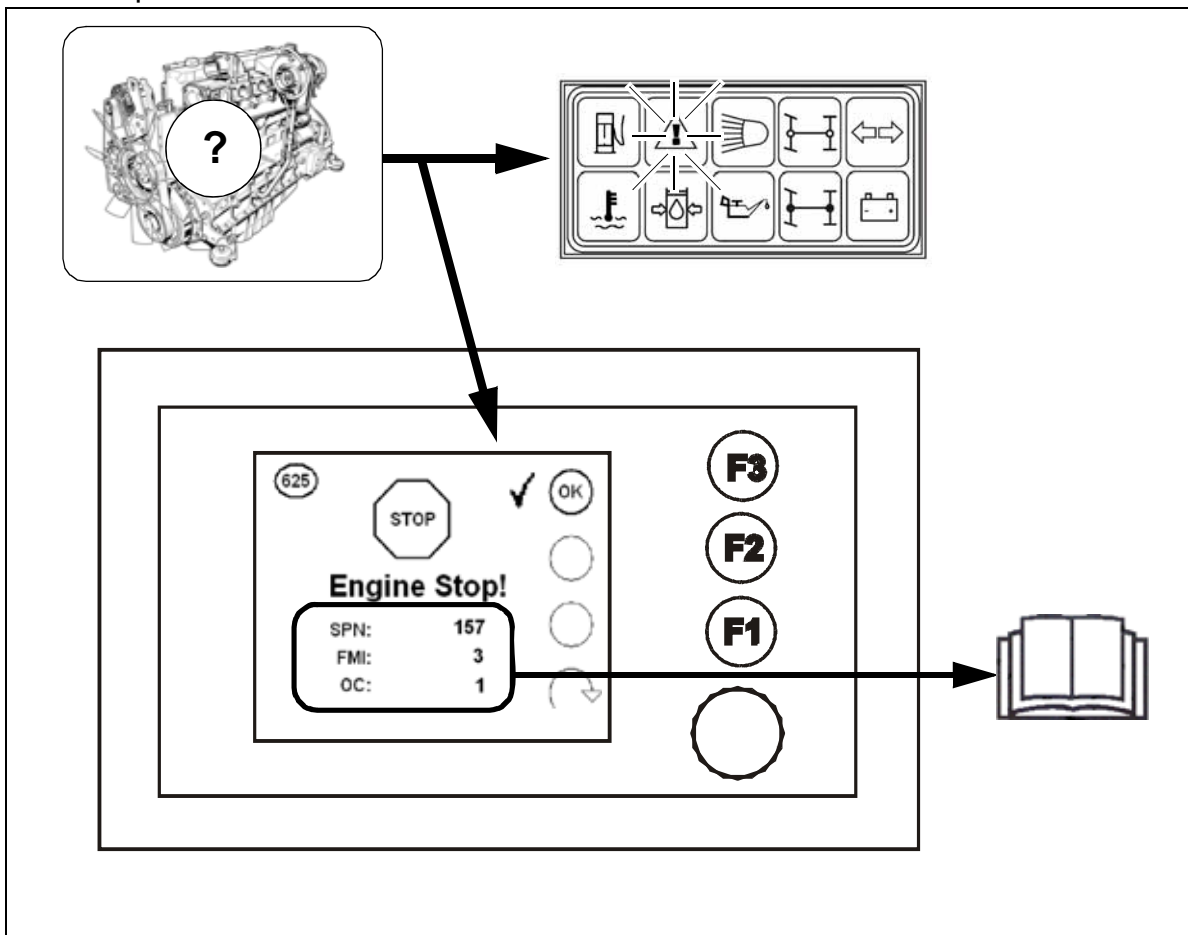

Explanation:

The flashing control lamp marks the serious failure of the traction engine and the engine will stop automatically or it has to be stopped.

Display:

SPN: 157
FMI: 3
OC: 1

Cause: Cable failure in the Rail pressure detector.

Effect: The engine switches off.

Frequency: The fault occurs for the first time.

m

Report the displayed fault code to the customer service of the paver finisher and they will discuss with you the steps to be taken.

2.3 Error messages

SPN	Component / Location	Description (Error location)	Defined for DCR DMV	Error code SERDIA	ID	Blink code	FMI	Self- curing ¹
29	Hand throttle	Cable break or short circuit; signal implausible compared to signal of idle sensor	●	138	HdThrt	1-2-6	2, 3, 4, 11	
84	Vehicle speed signal	Speed above target range; signal missing or implausible	●	232	VSSCD1	5-2-1	0, 8, 12, 14	●
91	Accelerator pedal	Cable break or short circuit; signal implausible compared to signal of idle sensor (analog pedal)	●	12	APP1	2-2-6	2, 3, 4, 11	
91	Accelerator pedal	Cable break or short circuit; bad PWM signal range or frequency (digital pedal)	●	14	APPPwm	2-2-2	2, 8	●
91	Accelerator pedal	Bad PWM pulse-width repetition rate (digital pedal)	●	15	APPPwmPer	2-2-2	8, 11	●
94	Fuel low pressure sensor	Cable break or short circuit	●	90	FIPSCD	2-1-6	3, 4, 11	●
94	Fuel low pressure	Below target range with system reaction	●	91	FIPSCDSysReac	2-1-6	2, 11	●
97	Fuel filter water level sensor	Cable break or short circuit	●	87	FIFCD	2-2-8	3, 4, 11	●
97	Water level in fuel filter	Above target range	●	89	FIFCD_WtLvl	2-2-8	11, 12	
100	Oil pressure sensor	Cable break or short circuit	●	196	OPSCD	2-2-4	0, 2, 3, 4	●
100	Oil pressure sensor	Pressure value implausible low	●	197	OPSCD1	2-3-1	1, 11	●
100	Oil pressure	Above target range	●	198	OPSCDSysReacHi	2-3-1	0, 11	●
100	Oil pressure	Below target range	●	199	OPSCDSysReacLo	2-3-1	1, 11	●
102	Charge air pressure sensor	Cable break or short circuit	●	32	BPSCD	2-2-3	2, 3, 4	●
102	Charge air pressure	Outside target range with system reaction	●	33	BPSCDSysReac	2-2-3	2, 11	●
105	Charge air temperature sensor	Cable break or short circuit	●	149	IATSCD	1-2-8	2, 3, 4, 11	●
105	Charge air temperature	Above target range with system reaction	●	150	IATSCDSysReac	2-3-3	0, 11	●
107	Air filter condition	Pressure loss above target range with system reaction	●	11	AirFltSysReac	1-3-6	0, 11	●
108	ECU internal error	Ambient pressure sensor defective	●	16	APSCD	2-9-2	2, 3, 4, 11	●
110	Coolant temperature sensor	Cable break or short circuit	●	56	CTSCD	2-2-5	2, 3, 4	●
110	Coolant temperature	Outside target range with system reaction	●	56	CTSCDSysReac	2-3-2	0, 11	●
111	Coolant level	Outside target range with system reaction	●	37	CLSCDSysReac	2-3-5	1, 11	
157	Rail pressure sensor	Cable break or short circuit	●	209	RailCD	1-4-7	3, 4, 11	
157	Rail pressure sensor	Deviation of signal during start or after-run above target range	●	210	RailCDOfsTst	1-4-7	0, 1, 11	●
158	Terminal 15	Ignition ON not detected	●	226	T15CD	5-1-4	11, 12	
168	Battery	Voltage below target range	●	22	BattCD	3-1-8	0, 1, 11	●
168	Battery voltage	Above target range with system reaction	●	23	BattCDSysReac	3-1-8	2, 11	●
174	Fuel temperature sensor	Fuel temp. sensor: cable break or short circuit	●	133	FTSCD	2-2-7	3, 4, 11	●
174	Fuel temperature	Above target range with system reaction	●	134	FTSCDSysReac	2-3-7	0, 11	●
175	Oil temperature sensor	Cable break or short circuit	●	201	OTSCD	1-4-4	2, 3, 4	●
175	Oil temperature	Below target range with system reaction	●	203	OTSCDSysReac	1-4-4	0, 11	●
190	Engine speed sensor	Engine running with cam-shaft speed signal only	●	75	EngMBackUp	2-1-2	11, 12	●

SPN	Component / Location	Description (Error location)	Defined for DCR DWV	Error code SERJIA	ID	Blink code	FMI	Self- curing ¹
190	Engine speed sensor	Speed signal from cam-shaft bad or missing	●	76	EngMcaS1	2-1-2	8, 11, 12	●
190	Engine speed sensor	Speed signal from crank-shaft bad or missing	●	77	EngMCRS1	2-1-2	8, 11, 12	●
190	Engine speed sensor	Speed signals of crank-shaft and cam-shaft are phase-shifted	●	78	EngMOfsCaScRS	2-1-3	2, 11	
190	Overspeed	Engine overspeed with system reaction	●	79	EngPriSysReacFOC	2-1-4	0, 11	
190	Overrun conditions	Overrun conditions with system reaction	●	80	EngPriSysReacORC	2-1-4	11, 14	●
520	CAN message	Missing (message "TSC1-TR")	●	126	FirmMngTOTSC1TR	1-1-9	11, 12	
563	Main relay	Short circuit to ground or emergency shut-off (relay 3)	●	187	MRyCDMnRly2	2-6-1	7, 11, 12	
624	Diagnostic lamp	Cable break or short circuit, disabled by ECU	●	225	SysLamp	5-1-3	2, 3, 4, 5	
630	ECU internal error	EEPROM memory access	●	142	HWEMonEEPROM	2-8-1	11, 12	
639	CAN bus off-state	Cable break or short circuit, off-state (CAN bus A)	●	192	NetMngCANAOFF	2-7-1	11, 14	●
651	Single injector	Short circuit (injector 1)	●	159	InjVivCy1A	1-5-4	3, 4, 11, 13	●
651	Single injector	Cable break (injector 1)	●	160	InjVivCy1B	1-5-4	5, 13	●
652	Single injector	Short circuit (injector 2)	●	161	InjVivCy2A	1-5-5	3, 4, 11, 13	●
652	Single injector	Cable break (injector 2)	●	162	InjVivCy2B	1-5-5	5, 13	●
653	Single injector	Short circuit (injector 3)	●	163	InjVivCy3A	1-5-6	3, 4, 11, 13	●
653	Single injector	Cable break (injector 3)	●	164	InjVivCy3B	1-5-6	5, 13	●
654	Single injector	Short circuit (injector 4)	●	165	InjVivCy4A	1-6-1	3, 4, 11, 13	●
654	Single injector	Cable break (injector 4)	●	166	InjVivCy4B	1-6-1	5, 13	●
655	Single injector	Short circuit (injector 5)	●	167	InjVivCy5A	1-6-2	3, 4, 11, 13	●
655	Single injector	Cable break (injector 5)	●	168	InjVivCy5B	1-6-2	5, 13	●
656	Single injector	Short circuit (injector 6)	●	169	InjVivCy6A	1-6-3	3, 4, 11, 13	●
656	Single injector	Cable break (injector 6)	●	170	InjVivCy6B	1-6-3	5, 13	●
657	Single injector	Short circuit (injector 7)	●	171	InjVivCy7A	1-6-4	3, 4, 11, 13	●
657	Single injector	Cable break (injector 7)	●	172	InjVivCy7B	1-6-4	5, 13	●
658	Single injector	Short circuit (injector 8)	●	173	InjVivCy8A	1-6-5	3, 4, 11, 13	●
658	Single injector	Cable break (injector 8)	●	174	InjVivCy8B	1-6-5	5, 13	●
676	Air heater relay	Cable break or wrong connection	●	19	ArHCD_NoLd	2-6-3	4, 11	
676	Air heater relay	Inoperable during shut-off	●	20	ArHCD_RlyErr	2-6-3	2, 5, 11	
677	Start relay	Start relay (high side): short circuit	●	223	StrtCDHS	5-1-2	3, 4, 11	
677	Start relay	Start relay (low side): cable break or short circuit, disabled by ECU	●	224	StrtCDLS	5-1-2	3, 4, 5, 11	
701	Reserve output	Short circuit to Ubatt (output 1)	●	57	Dummy1CD_Max	-	11	
701	Reserve output	Short circuit to ground (output 1)	●	58	Dummy1CD_Min	-	11	
701	Reserve output	Cable break or ECU internal error (output 1)	●	59	Dummy1CD_SigNpl	-	11	
702	Reserve output	Short circuit to Ubatt (output 2)	●	60	Dummy2CD_Max	-	11	

SPN	Component / Location	Description (Error location)	Defined for DCR DMV	Error code SERUIA	ID	Blink code	FMI	Self-curing ¹
702	Reserve output	Short circuit to ground (output 2)	●	61	Dummy2CD_Min	-	11	
702	Reserve output	Cable break or ECU internal error (output 2)	●	62	Dummy2CD_SigNpl	-	11	
703	Engine operating signal lamp	Cable break or ECU internal error	●	81	ESLpCD	1-4-2	2, 3, 4, 5	
704	Coolant temperature warning lamp	Cable break or short circuit	●	54	CTLpCD	1-2-3	11	
705	Oil pressure warning lamp	Cable break or short circuit	●	195	OPLpCD	1-3-5	2, 3, 4, 5	
729	Air heater relay	Cable break or short circuit	●	17	ArH1	2-6-3	3, 4, 5, 11	●
730	Air heater magnetic valve	Cable break or short circuit	●	18	ArH2	2-6-3	3, 4, 5, 11	●
898	CAN message	Missing (message "TSC1-TE")	●	125	FrmMngTOTSC1TE	1-1-8	11, 12	
923	Engine power output	Engine Power output: cable break or short circuit	●	74	EngCDTrqCalcOut	5-5-5	2, 3, 4, 5	
975	Fan actuator	Fan actuator: cable break or short circuit	●	83	FanCD	2-3-8	2, 3, 4, 5	
1072	Engine brake (internal)	Internal engine brake: cable break or short circuit	●	52	CREECD	5-2-8	3, 4, 5, 11	
1074	Engine brake flap actuator	Engine brake flap actuator: cable break or short circuit	●	82	EXFICD	2-1-9	3, 4, 5, 11	
1079	ECU internal error	Wrong voltage of internal 5V reference source 1	●	219	SSpMon1	2-8-2	3, 4, 11	●
1080	ECU internal error	Wrong voltage of internal 5V reference source 2	●	221	SSpMon2	2-8-2	3, 4, 11	●
1081	Preheating signal lamp	Cable break or short circuit	●	53	CSLpCD	3-2-8	2, 3, 4, 5	
1109	Shut-off request	Shut-off request ignored by operator	●	48	CoEngShoOffDemigr	3-4-1	2, 11	
1231	CAN bus off-state	Cable break or short circuit, off-state (CAN bus B)	●	193	NetMngCANBOff	2-7-1	11, 14	●
1235	CAN bus off-state	Cable break or short circuit, off-state (CAN bus C)	●	194	NetMngCANCOff	2-7-1	11, 14	●
1237	Override switch	Switch hangs	●	200	OSWCD	1-4-5	2, 11	●
1322	Multiple cylinders	Misfire detected	●	46	CmbChbMisfireMul	2-4-1	11, 12	
1323	Single cylinder	Misfire detected (cylinder 1)	●	38	CmbChbMisfire1	2-4-1	11, 12	
1324	Single cylinder	Misfire detected (cylinder 2)	●	39	CmbChbMisfire2	2-4-1	11, 12	
1325	Single cylinder	Misfire detected (cylinder 3)	●	40	CmbChbMisfire3	2-4-1	11, 12	
1326	Single cylinder	Misfire detected (cylinder 4)	●	41	CmbChbMisfire4	2-4-1	11, 12	
1327	Single cylinder	Misfire detected (cylinder 5)	●	42	CmbChbMisfire5	2-4-1	11, 12	
1328	Single cylinder	Misfire detected (cylinder 6)	●	43	CmbChbMisfire6	2-4-1	11, 12	
1346	Misfire	Misfire detected with system reaction	●	47	CmbChbSysReac	2-4-1	0, 11	
1450	Single cylinder	Misfire detected (cylinder 7)	●	44	CmbChbMisfire7	2-4-1	11, 12	
1451	Single cylinder	Misfire detected (cylinder 8)	●	45	CmbChbMisfire8	2-4-1	11, 12	
1638	Customer-specific sensor	Cable break or short circuit (sensor 2)	●	139	HOTSCD	3-1-4	3, 4, 11, 12	●
1638	Customer-specific temperature	Outside target range with system reaction (temperature 2)	●	140	HOTSCDSysReac	3-1-4	2, 11	●
2634	Main relay	Short circuit to Ubatt (relay 1)	●	182	ImRly1_SCB	1-3-7	3, 11	
2634	Main relay	Short circuit to ground (relay 1)	●	183	ImRly1_SCG	1-3-8	4, 11	
2634	Main relay	Short circuit to ground or emergency shut-off (relay 2)	●	186	MRyCD	2-6-1	7, 11, 12	

SPN	Component / Location	Description (Error location)	Defined for		Error code SERDIA	ID	Blink code	FMI	Self-curing ¹
			DCR	DWM					
2634	Main relay	Short circuit to ground or emergency shut-off (relay 3)	●	●	188	MRyCDMnRly3	2-6-1	7, 11, 12	
2791	EGR actuator (external)	Short circuit to Ubatt	●	●	69	EGRCD_Max	4-1-4	3, 11	
2791	EGR actuator (external)	Short circuit to ground	●	●	70	EGRCD_Min	4-1-4	4, 11	
2791	EGR actuator (external)	Cable break or ECU internal error	●	●	71	EGRCD_SigNpl	4-1-5	2, 5, 11	
2791	EGR actuator (external)	Cable break or short circuit	●	●	72	EGRCD_IniEGR	4-1-6	2, 3, 4, 5	
523212	CAN message	Missing (message "EngPrnt" = engine protection)	●	●	106	FrmMngTOEngPrnt	3-3-3	11, 12	●
523216	CAN message	Missing (message "PRHtEnCmd" = preheat and engine command)	●	●	110	FrmMngTOPRHEncmd	3-3-7	11, 12	●
523218	CAN message	Missing (message "RxCcVS" = cruise control)	●	●	112	FrmMngTORxCcVS	1-1-1	11, 12	●
523222	CAN message	Missing (message "TCOI" = speedo signal)	●	●	118	FrmMngTOTCOI	1-1-6	11, 12	●
523238	CAN message	Missing (message "SwfOut" = switch outputs)	●	●	117	FrmMngTOSwfOut	1-1-5	11, 12	●
523239	CAN message	Missing or value above target range (message "DecV1" = pseudo pedal)	●	●	94	FrmMngDecV1	5-2-6	2, 12	●
523240	CAN message	Missing (message "FunModCtl" = function mode control)	●	●	95	FrmMngFunModCtl	5-2-7	11, 12	●
523350	Multiple injectors	Short circuit (cylinder bank 1)	●	●	153	InjVwBnk1A	1-5-1	3, 4, 11, 13	●
523351	Multiple injectors	Cable break (cylinder bank 1)	●	●	154	InjVwBnk1B	1-5-1	5, 13	●
523352	Multiple injectors	Short circuit (cylinder bank 2)	●	●	155	InjVwBnk2A	1-5-2	3, 4, 11, 13	●
523353	Multiple injectors	Cable break (cylinder bank 2)	●	●	156	InjVwBnk2B	1-5-2	5, 13	●
523354	ECU internal error	Injector power stage A	●	●	157	InjVwChipA	1-5-3	2, 3, 12, 14	
523355	ECU internal error	Injector power stage B	●	●	158	InjVwChipB	1-5-3	12	
523370	Rail pressure	Compression test active: rail-pressure monitoring is going to be disabled	●	●	175	InjVwErDet	5-5-5	11, 14	
523420	ECU internal error	Watchdog counter exceeds maximum	●	●	184	Montr	1-3-9	11, 14	
523450	Multi state switch	Cable break or short circuit, input voltage outside target range (switch 1)	●	●	189	MSSCD1	1-4-3	2, 3, 4, 11	●
523451	Multi state switch	Cable break or short circuit, input voltage outside target range (switch 2)	●	●	190	MSSCD2	1-4-3	2, 3, 4, 11	●
523452	Multi state switch	Cable break or short circuit, input voltage outside target range (switch 3)	●	●	191	MSSCD3	1-4-3	2, 3, 4, 11	●
523470	Rail pressure limiting valve	Opening failure	●	●	208	PRVMon	1-4-6	2, 11, 12, 14	
523470	Rail pressure limiting valve	Opening failure with system reaction	●	●	236	PRVMonSysReac	1-4-6	11, 12	
523490	ECU internal error	Redundant shut-off conditions detected	●	●	218	SOPTst	1-4-9	3, 4, 11, 12	
523500	CAN message	Time-out of at least one send message	●	●	131	FrmMngTXTO	2-7-1	11, 12	●
523550	Terminal 50	Engine start switch hangs	●	●	227	T50CD	5-1-5	11, 12	
523550	ECU internal error	Time processing unit (TPU) defective	●	●	228	TPUMon	5-5-5	2, 11	
523561	Begin of injection period	Outside target range or missing (cylinder 1)	●	●	24	BIPCy1	5-3-1	2	●
523562	Begin of injection period	Outside target range or missing (cylinder 2)	●	●	25	BIPCy2	5-3-2	2	●
523563	Begin of injection period	Outside target range or missing (cylinder 3)	●	●	26	BIPCy3	5-3-3	2	●
523564	Begin of injection period	Outside target range or missing (cylinder 4)	●	●	27	BIPCy4	5-3-4	2	●
523565	Begin of injection period	Outside target range or missing (cylinder 5)	●	●	28	BIPCy5	5-3-5	2	●

SPN	Component / Location	Description (Error location)	Defined for		Error code SERIA	ID	Blink code	FMI	Self-curing ¹
			DCR	DMV					
523666	Begin of injection period	Outside target range or missing (cylinder 6)		●	29	BPCyl6	5-3-6	2	●
523667	Begin of injection period	Outside target range or missing (cylinder 7)		●	30	BPCyl7	5-3-7	2	●
523668	Begin of injection period	Outside target range or missing (cylinder 8)		●	31	BPCyl8	5-3-8	2	●
523600	ECU internal error	Serial communication interface defective		●	235	WdCom	5-5-5	11, 12	
523601	ECU internal error	Wrong voltage of internal 5V reference source 3		●	222	SSpMon3	2-8-2	3, 4, 11	●
523602	Fan speed	Above target range with system reaction		●	86	FanCDSysReac	2-3-8	2, 11	●
523604	CAN message	Missing (message "RxEngTemp" = engine temperature)		●	113	FrmMngTORxEngTemp	1-1-2	11, 12	●
523605	CAN message	Missing (message "TSC1-AE")		●	120	FrmMngTOTSC1AE	1-1-8	11, 12	
523606	CAN message	Missing (message "TSC1-AR")		●	121	FrmMngTOTSC1AR	1-1-9	11, 12	
523607	CAN message	Missing (message "TSC1-DE")		●	122	FrmMngTOTSC1DE	1-1-8	11, 12	
523608	CAN message	Missing (message "TSC1-DR")		●	123	FrmMngTOTSC1DR	1-1-9	11, 12	
523609	CAN message	Missing (message "TSC1-PE")		●	124	FrmMngTOTSC1PE	1-1-8	11, 12	
523610	CAN message	Missing (message "TSC1-VE")		●	127	FrmMngTOTSC1VE	1-1-8	11, 12	
523611	CAN message	Missing (message "TSC1-VR")		●	128	FrmMngTOTSC1VR	1-1-9	11, 12	
523612	ECU internal hardware monitoring	A recovery occurred which is stored as protected		●	143	HWEMonRcyLocked	5-5-5	11, 14	
523612	ECU internal hardware monitoring	A recovery occurred which is not stored		●	144	HWEMonRcySuppressed	5-5-5	11, 14	
523612	ECU internal hardware monitoring	A recovery occurred which is visible in the error memory		●	145	HWEMonRcyVisible	5-5-5	11, 14	
523612	ECU internal hardware monitoring	Overvoltage		●	146	HWEMonUMaxSupply	5-5-5	3, 11	
523612	ECU internal hardware monitoring	Undervoltage		●	147	HWEMonUMinSupply	5-5-5	4, 11	
523613	Rail pressure	Positive deviation (speed dependent) outside target range		●	211	RailMeUn0	1-3-4	0, 11	●
523613	Rail pressure	Positive deviation (flow dependent) outside target range (⇒ leakage)		●	212	RailMeUn1	1-3-4	0, 11	●
523613	Rail pressure	Negative deviation (flow dependent) outside target range		●	213	RailMeUn2	1-3-4	0, 11	●
523613	Rail pressure	Negative deviation (speed dependent) outside target range		●	214	RailMeUn3	1-3-4	1, 11	●
523613	Rail pressure	Pressure above target range		●	215	RailMeUn4	1-3-4	0, 11	●
523613	Rail pressure	Implausible (leakage, injector needle blocked in open position)		●	216	RailMeUn7	1-3-4	2, 11	●
523615	Metering unit valve	Flow rate outside target range		●	176	MeUnCD_ADC	1-3-5	3, 4, 11	
523615	Metering unit valve	Not connected or output disabled		●	177	MeUnCDNoLoad	1-3-5	5, 11, 12	
523615	Metering unit valve	Short circuit to Ubatt		●	178	MeUnCDSCBat	1-3-5	11, 12	
523615	Metering unit valve	Short circuit to ground		●	179	MeUnCDSCGnd	1-3-5	11, 12	
523617	ECU internal error	Communication with chip CJ 940 disturbed		●	141	HWEMonCom	5-5-5	11, 12	
-	Customer-specific sensor	Cable break or short circuit (sensor 1)		●	136	GOTSCD	1-3-3	2, 3, 4, 11	●
-	Customer-specific temperature	Outside target range with system reaction (temperature 1)		●	137	GOTSCDSysReac	1-3-3	2, 11	●

2.4 FMI-codes

FMI	Description	FMI	Description
0	Data valid but above normal operational range	8	Abnormal frequency, pulse width, or period
1	Data valid but below normal operational range	9	Abnormal update rate
2	Data erratic, intermittent, or incorrect	10	Abnormal rate of change
3	Voltage above normal or shorted high	11	Failure mode not identifiable
4	Voltage below normal or shorted low	12	Bad intelligent device or component
5	Current below normal or open circuit	13	Out of Calibration
6	Current above normal or grounded circuit	14	Special Instructions
7	Mechanical system not responding properly	15	Reserved

2.5 Special functions

Emergency operation program for the case of keyboard failure

To ensure the pavers operating ability during a display failure, an emergency program will be started automatically.

Following setting and functions will be adjusted and switched on:

- Number of revolutions of the Diesel engine: 1800 min⁻¹
- Traction drive (1) slow (Tortoise)
- Operating main switch (2) OFF
- Tamper (3) switched on
- Vibration (4) switched on

m

Connected functions will not be indicated by LED during a display failure!

A

Tamper and vibration can be deactivated by the associated rotary potentiometer (set to „zero“).

The frequency of the tamper and vibration can be read off the two associated displays (O).

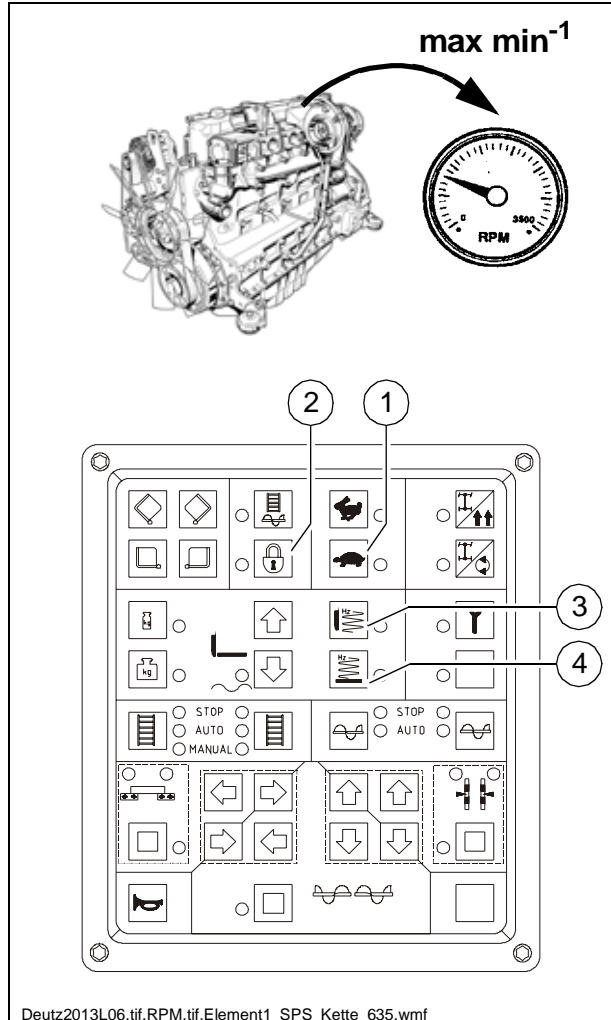

Accessory the following function can be switched by using the remote controls:

- Press button (1) to close the hopper.
- Press button (2) to open the hopper.
- Lifting the screed:
 - Switch off the LED bar (3) of auger and conveyor completely by using the accompanying Minus-buttons (4).
 - Lift the screed infinitely variable by using both Minus-buttons(4) simultaneously.
- Switching the screed into readiness (floating position):
 - Switch the LED bar (3) of auger and conveyor completely on by using the accompanying Plus-buttons (5).
 - Switch the screed into floating position by pressing both Plus-buttons (5) simultaneously.

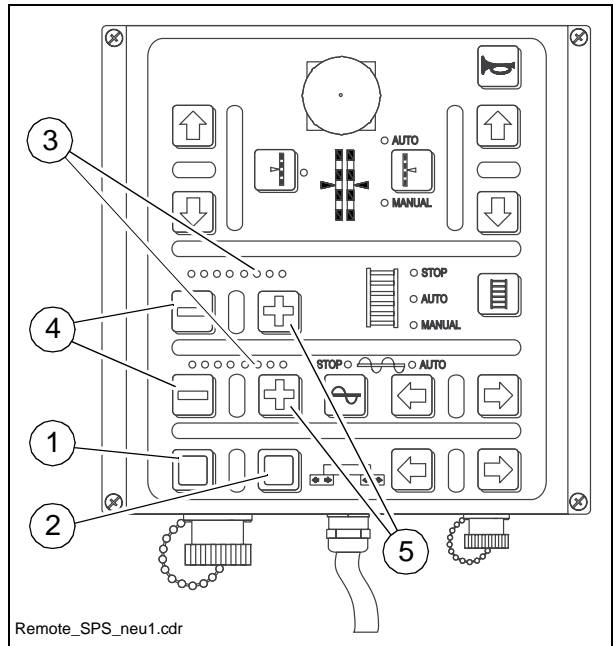

m The screed sinks immediately.

A To lift the screed out of floating position, the LED bar of auger and conveyor must be deleted again.

Reversible conveyor

The direction of transport of the conveyor can be changed over to the opposite direction to move material located just in front of the auger back slightly. Material losses, e.g. during transport operations can therefore be avoided.

- Switch main function switch (16) over to „Off“ switch position (LED off).
- Hold down one or both of the buttons (32) in the „STOP“ switch position for approx. 5 seconds.
The system jumps into the „Manual“ switch position and the conveyor moves approx. 1 metre towards the hopper. The system then jumps back into the „Stop“ switch position.

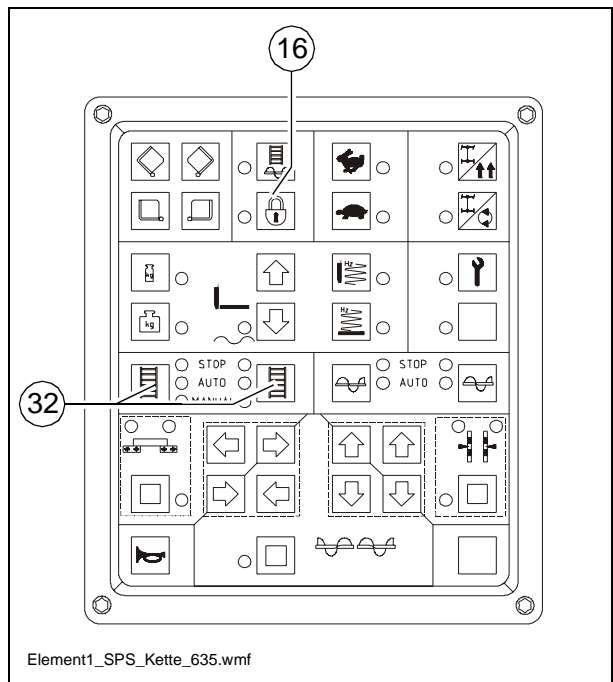

If necessary, this process can be repeated as many times as required to allow the conveyor to move further in the opposite direction.

D 3.2 Operation

1 Operating elements on the paver finisher

Engine hood (70)

For inspection and maintenance works the engine compartment lid can be fully opened for easy access. To open the lid pull lever (a) (on the light hand side behind the side lid). For this purpose both sides of the hopper must be open

m Secure the hinged side cover with the respective support rods.

f Open the engine hood only if the engine is stopped. Do not touch the cooling fan or the driven belt. (See also engine instructions for safety.)

f Do not touch the hot exhaust pipe! Danger of burn!

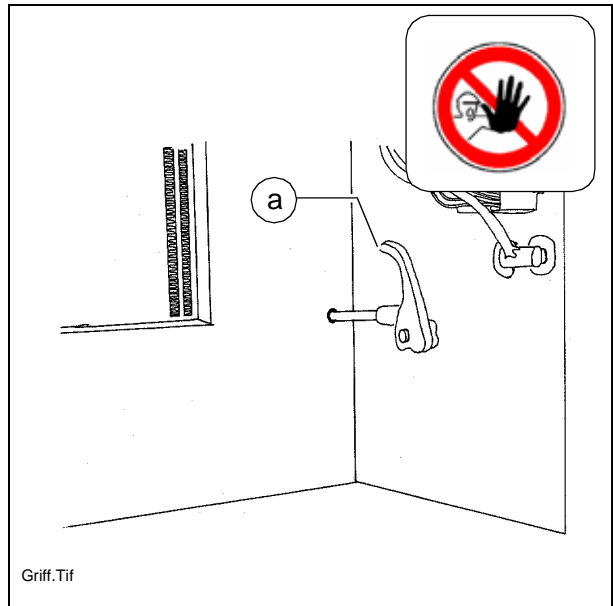

Batteries (71)

The batteries of the 24 V system are located under the left maintenance flap.

A For the specifications, refer to chapter B, "Technical Data".
For servicing, see chapter F.

m Heed the instructions when starting the paver finisher externally. (see section "Starting the paver finisher, External starting (starting aid)".

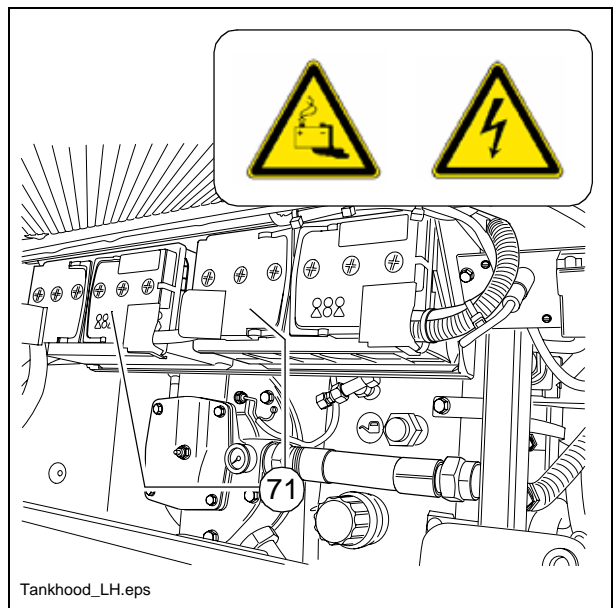

Battery main switch (72)

The main switch interrupting the circuit between the battery and the main fuse is located under the left maintenance flap.

m Secure the open service lid with the outrigger rod.

A For the assignment of all fuses, see chapter F.

- For switching off, turn the key (72) to the left and pull it out.

A Do not lose the key as in this case the paver finisher can no longer be moved!

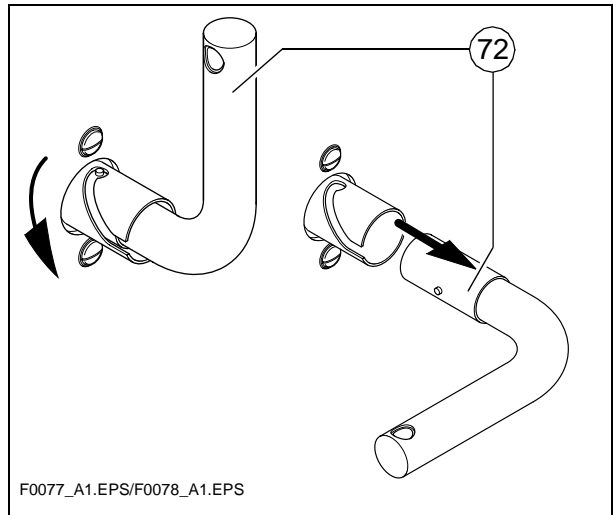
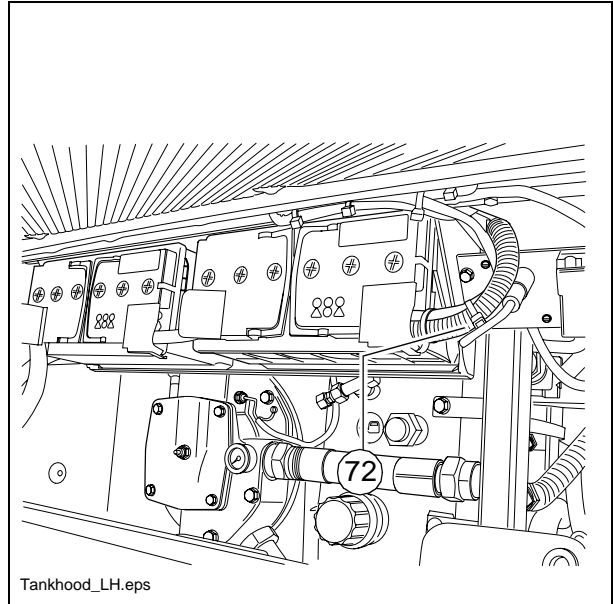

Transport safeguards for the hopper (73)

Before parking or transporting the paver finisher, the hopper halves must be swung upwards and the transport safeguards for the hopper must be inserted.

Item:

- (a) - outside on the two half-hoppers
- or
- (b) - in the feeding hopper (○)

f

Do not enter the hopper while the engine is running! Danger of being caught by the conveyor!

Without transport safeguards inserted, the hopper halves will slowly open; danger during transportation!

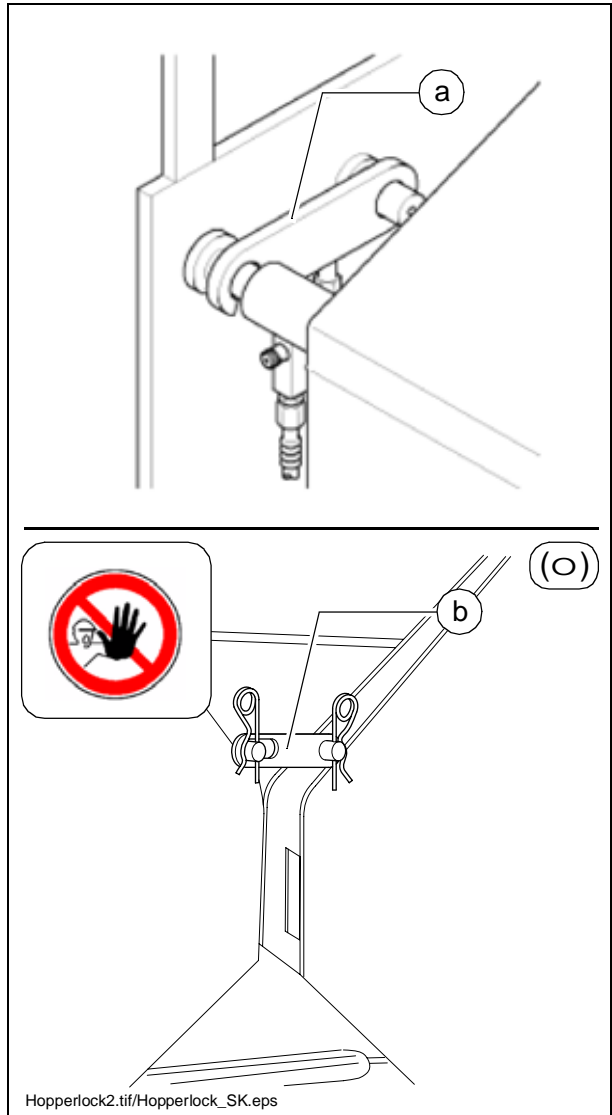

Mechanical screed transport safeguard (to the left and the right beneath the driver's seat) (74)

It is used to protect the lifted screed from inadvertent lowering. The screed transport safeguard must be inserted before transportation and when work is finished.

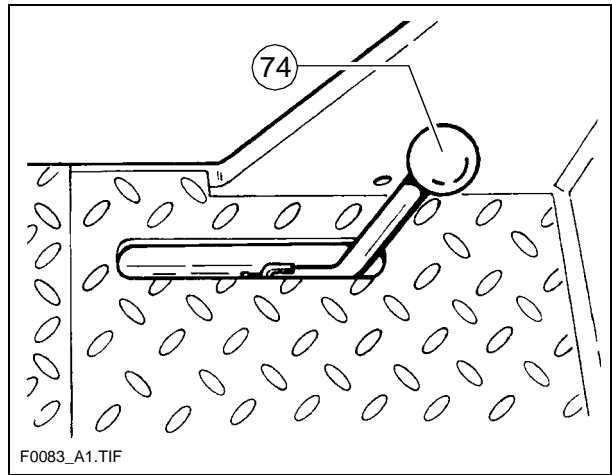

f Transportation with an unsecured screed bears the danger of accidents!

- Lift the screed.
- Actuate the levers.
- Check that the latches (to the left and to the right) engage in the crossbeams.

m **ATTENTION!**
Insert screed lock only at crown adjustment „zero“! Screed lock only for transportation
Use the interlocking of the main girder for transportation only!
Do not enter or work under screed only secured with screed lock for transportation!
Danger of accident!

Seat lock (behind the driver's seat) (75)

Telescoping seats (○) can be extended beyond the basic width of the paver finisher. They must be locked.

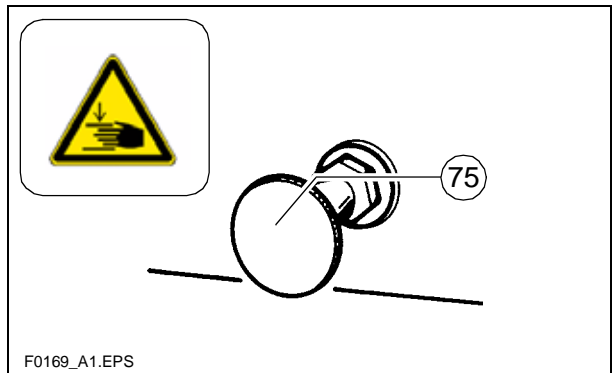

f The seats must not protrude from the vehicle during transportation. Push the seats back to the basic width of the paver finisher!

- Pull out the locking button and move the seat; let the locking button engage again.

f The driver's seat can move when the locking button is not engaged properly. Danger of accidents during transportation!

Service brake („foot brake“) (76)

There is a brake pedal each before the driver's seats on the LH and RH sides. The service brake acts within the machine drive.

A Upon operating the brake, the machine drive is regulated to stop automatically (regardless of the position of the drive lever).

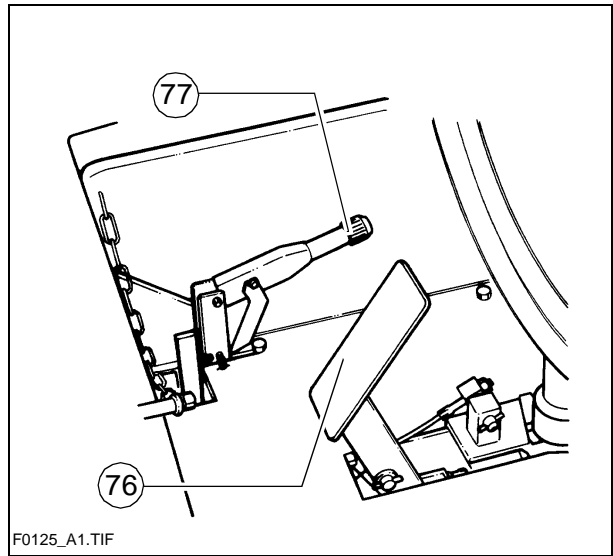

Parking brake („Hand Brake“) (77)

The brake lever is located on the left hand side of the driver's seat (optionally on both sides). The parking brake mechanically acts on one disc brake on the main drive shaft.

f When stopping the paver finisher always apply the brake!

Change lever of the two-stage transmission (78)

The change lever has three positions:

- ◀ = working stage
- 0 = neutral
- ◀◀ = travel stage

m Before changing over pull in the parking brake. Only change the speed when the paver finisher is at a standstill!

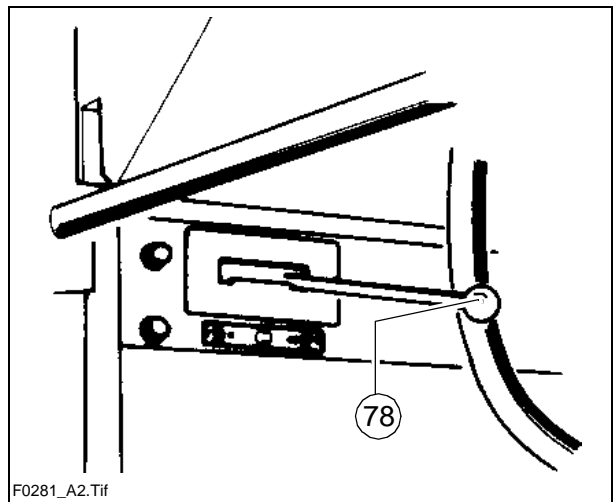

- If the speed cannot be changed, slightly move the drive lever.

m When towing the paver finisher (e.g. when the Diesel engine failed) use the neutral position. Otherwise the transmission may fail.

With the hare / tortoise positions the drive lever can be set to 4 different positions:

Combination	Use
◀ ◀◀	Paving speed slow
◀◀ ◀◀	Travel speed slow
◀ ◀◀	Paving speed fast
◀◀ ◀◀	Travel speed fast

Change lever of the differential lock (79)

This is to turn on and off the differential lock (also see switch on the control panel).

Turning on:

- Pull the lever to the right; the „Differential Lock“ control light is on if the lock is engaged.

Switching off:

- Pull the lever to the left; move the machine until the „Differential Lock“ light goes dark.

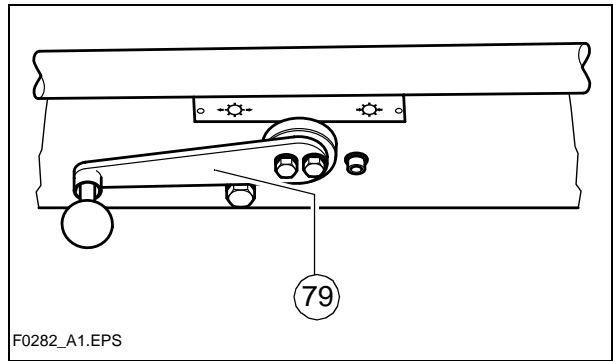

- A See section „Differential Lock“ control light for use and risks.

Separator fluid spraying system (80) (o)

Used to spray the parts coming into contact with asphalt with a separator emulsion.

- The indicator lamp (A) lights up when the emulsion pump is running
- On/off switch (B) for the emulsion pump
- Quick-release coupling (C) for hose connection

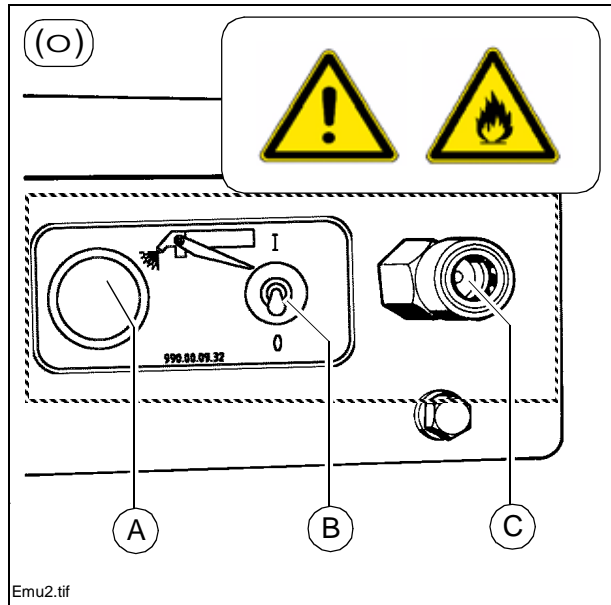

m Only switch on the spraying system when the diesel engine is running; otherwise, the battery will be discharged. Switch off after use.

A A permanent installed hose guide (D) for the fluid spraying system is available as an option.

Pull hose out of the guide till there is an audible creak. The hose will engage in this position after discharging. The hose will be retracted automatic into the guide after pulling and discharging again.

f Don't spray into open flame or on hot surface! Danger of explosion!

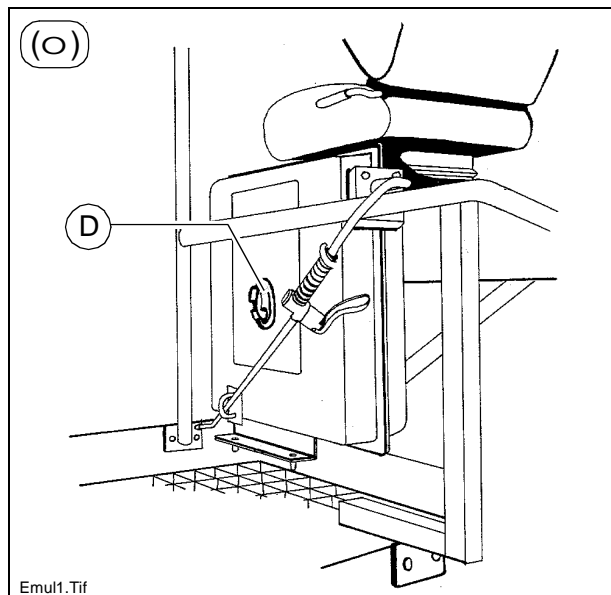

A The spraying system is fed by a can (E) under the side flap on R.H. side.

f Refill the can only while standstill of the paver finisher!

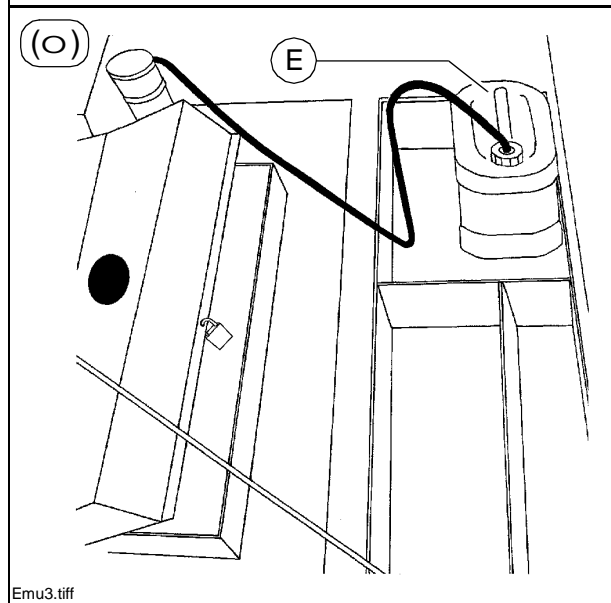

A Further switch options for optional equipment features may be located on the central panel:

On / off switch for additional headlight in the roof (85):

Actuate switch (a) to activate.

On / off switch for fuel tank filler pump (85a)

If the pump is actuated with the switch (a), the indicator lamp (b) lights up.

f When fuelling, ensure that no fuel penetrates the earth. Switch off the engine and do not smoke. Do not fuel in enclosed spaces. Danger to health! Have a fire extinguisher ready.

On / off switch special lighting (85b)

If the machine is equipped with additional headlights, these are actuated by means of the switch (a). When switched to the „ON“ position, the indicator lamp (b) lights up.

m Switch the additional headlights and special lighting off when the engine is not running, as the battery is otherwise discharged!

On / Off switch Exhaust of asphalt vapours (85c)

In case of the availability of optional asphalt vapour exhaust system, this can be turned on by switch (a). In the switch position „ON“ the control light (b) is on.

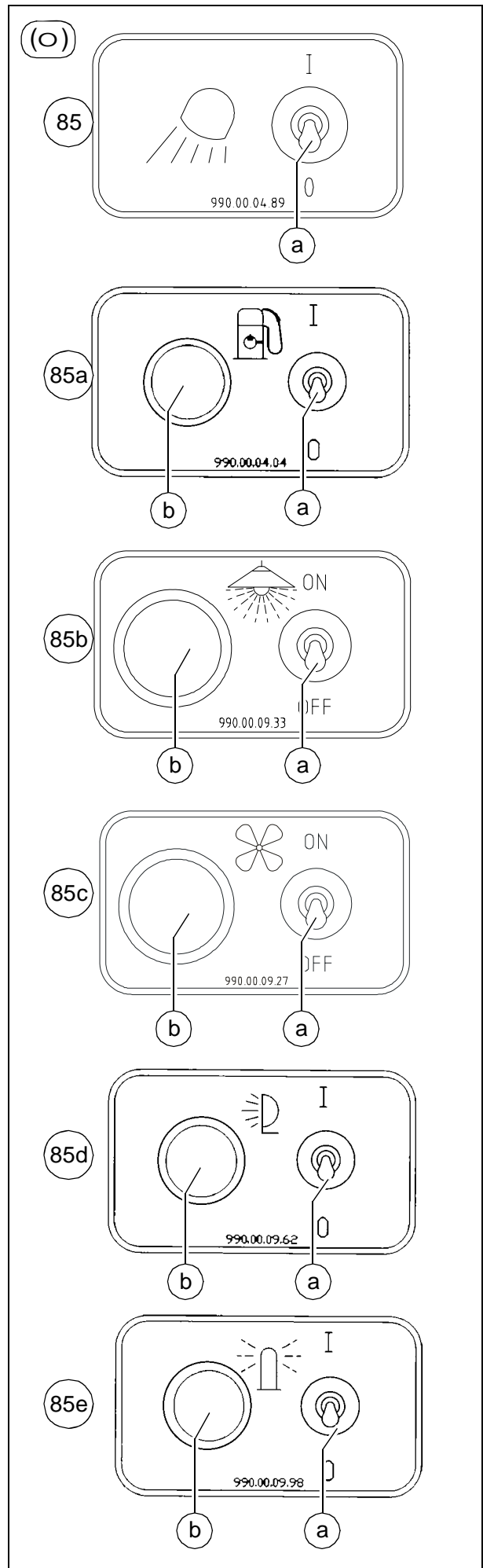

On/Off switch of work headlights (85d):

Actuate switch (a) to switch on.

In the switch position „ON“ the control light (b) is on.

On/Off switch of flasher (85e):

Actuate switch (a) to switch on.

In the switch position „ON“ the control light (b) is on.

A

If optionally available 230 V systems are installed, an additional switch cabinet is mounted on the paver finisher:

230 V On / Off switch Connection sockets (85f)

In case of being equipped with 230 V accessories, the connection sockets can be powered through switches. In the switch position „I“ the control light (b) is on.

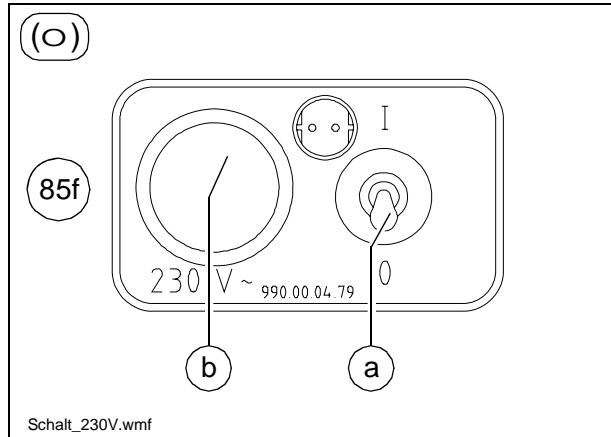

Locking of the collapsible roof (LH and RH on the roofs console) (86)

To lower the roof (for example during transport on a low bed trailer):

- Loose the twistlock (A)
- Pull the roof frame forward holding the clevis or the frame
- Arrest the twistlock in the second locking hole.

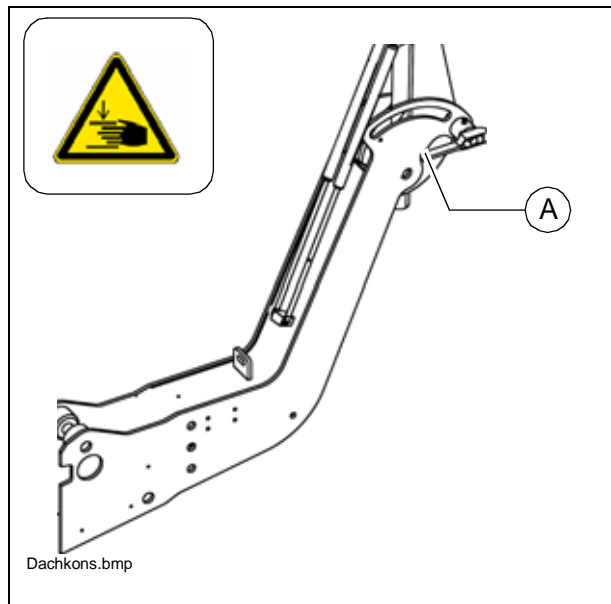

Hydraulic folding roof (87) (○)

The hydraulically folding roof is secured by means of a latch (A) at the rear suspension on the left and right sides of the machine. This must be released prior to lowering and raising. Once it has reached its terminal position, the roof must be secured with the latch again. The hydraulic unit and the key-operated switch (A) for actuating the folding roof hydraulic system are located on the left side of the paver finisher's rear panel.

A The roof can be raised and lowered without having to start the drive motor.

- In order to lower the roof, turn the key-operated switch (B) to the right until the roof has been lowered to its minimum level.

f Danger of crushing! Ensure that nobody inserts their fingers or hands into the joint areas or are placed at risk by the lowering roof during the folding procedure.

- In order to raise the roof again, turn the key-operated switch (B) to the left until the roof has been raised to its maximum height.

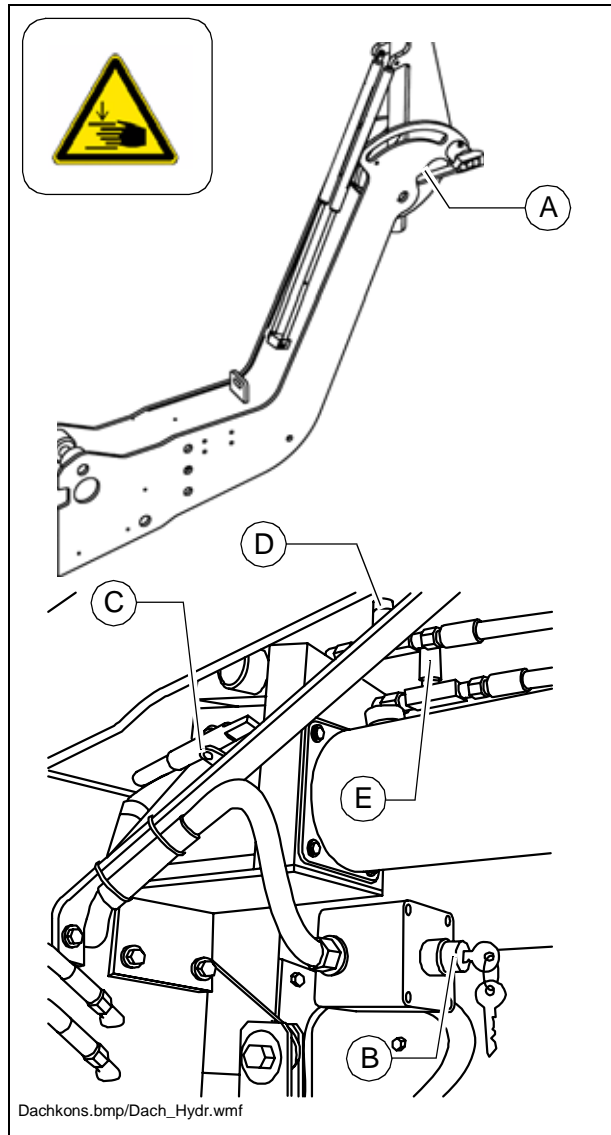

If it is necessary to raise the roof whilst the battery is discharged, a manual pump is available on the hydraulic unit.

- Actuate the pump lever (C) until the roof can be secured with the latch bolt (A) in its uppermost position.

Two throttles are installed to adjust the raising and lowering speed:

- Throttle valve (D): Adjust roof raising speed.
Turning the adjusting knob in the clockwise direction = lower speed.
Turning anti-clockwise = higher speed.
- Throttle valve (E): Adjust roof lowering speed.
Turning the adjusting knob in the clockwise direction = lower speed.
Turning anti-clockwise = higher speed.

Electric setting of the transportation volume of the conveyor (○) (88)

With this the transport volume of the conveyor can be adjusted when mechanical limit switch or ultrasonic sensor is used.

- The „0“ position of the scale corresponds to the smallest adjustable volume.
- RH-side conveyor: (88a)
- LH-side conveyor: (88b)

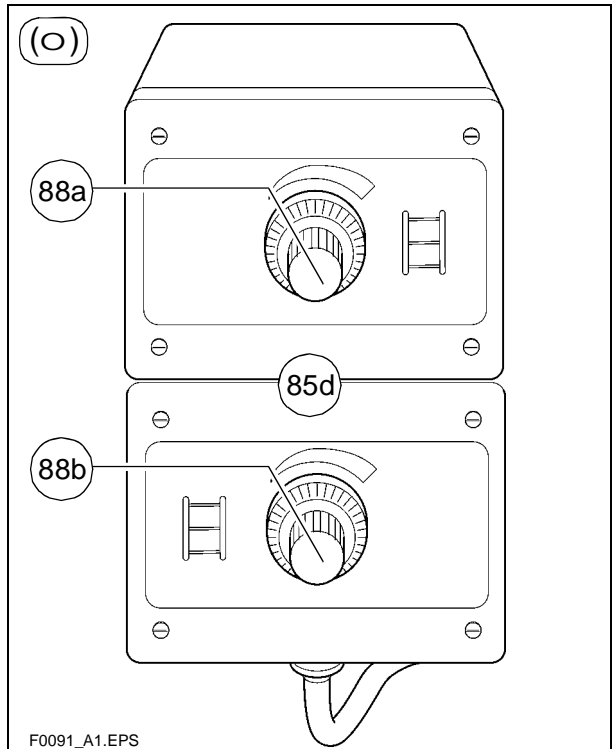

Conveyor limit switches (89):

The mechanical conveyor limit switches (89) or the ultrasonic conveyor limit switches (89a○) control the material flow at the respective conveyor half. The conveyors should stop when the material has roughly reached the area below the auger tube.

- A This requires that the auger height has been adjusted correctly (see chapter E).

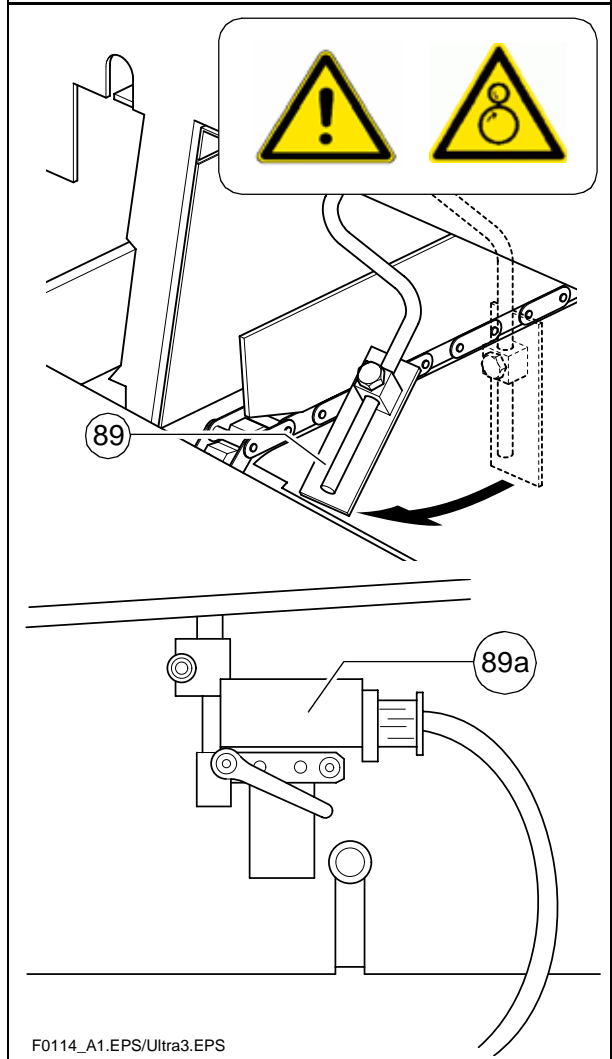

Ultrasonic auger limit switches (90) (left and right)

A The limit switches control the material flow at the respective auger half.

The ultrasonic sensor is mounted by means of an appropriate leverage to the side plate. Loose clamping lever for adjustment and modify angle / height of the sensor.

The cables must be connected to the remote control units located at the sides of the screed.

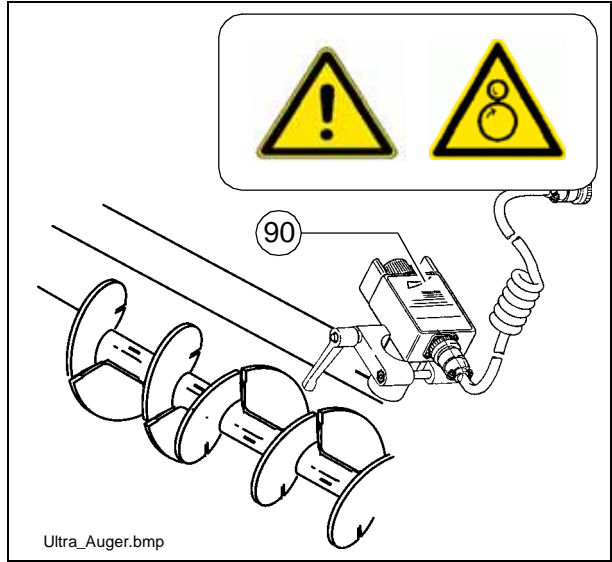

A We recommend to adjust the limit switch positions while the material is distributed.

Sockets for working lights (left and right) (92)

Connect the working lights (24 V) here.

- Power is present when the main switch (72) is switched on.

A As an option, one socket can be used to provide power for an electrically heated seat.

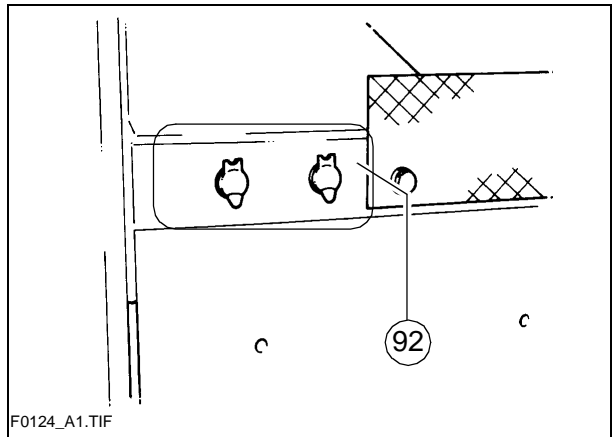

Pressure control valve for screed charging/relieving (93) (○)

Used to adjust the pressure for additional charging/relieving of the screed.

- See "screed charging/relieving device". (Chapters „Operating Panel“, „Operation“).
- Pressure display: see manometer (93b).

Pressure control valve for screed stop with pretensioning (93a) (○)

This valve is located beneath the right-hand bottom flap of the operator's platform.

It is used to adjust the pressure for "screed stop with pretensioning".

- Activation: see "screed charging/relieving device".
- Pressure display: see "manometer" (93b).

Manometer for screed charging/relieving and screed stop with pretensioning (93b)

Displays the pressure for

- Screed stop with pretensioning screed stop with pretensioning when the drive lever is set to the neutral position (pressure to be adjusted using valve (93a));

Screed charging/relieving device when the drive lever is in the third position (pressure to be adjusted using valve (93)).

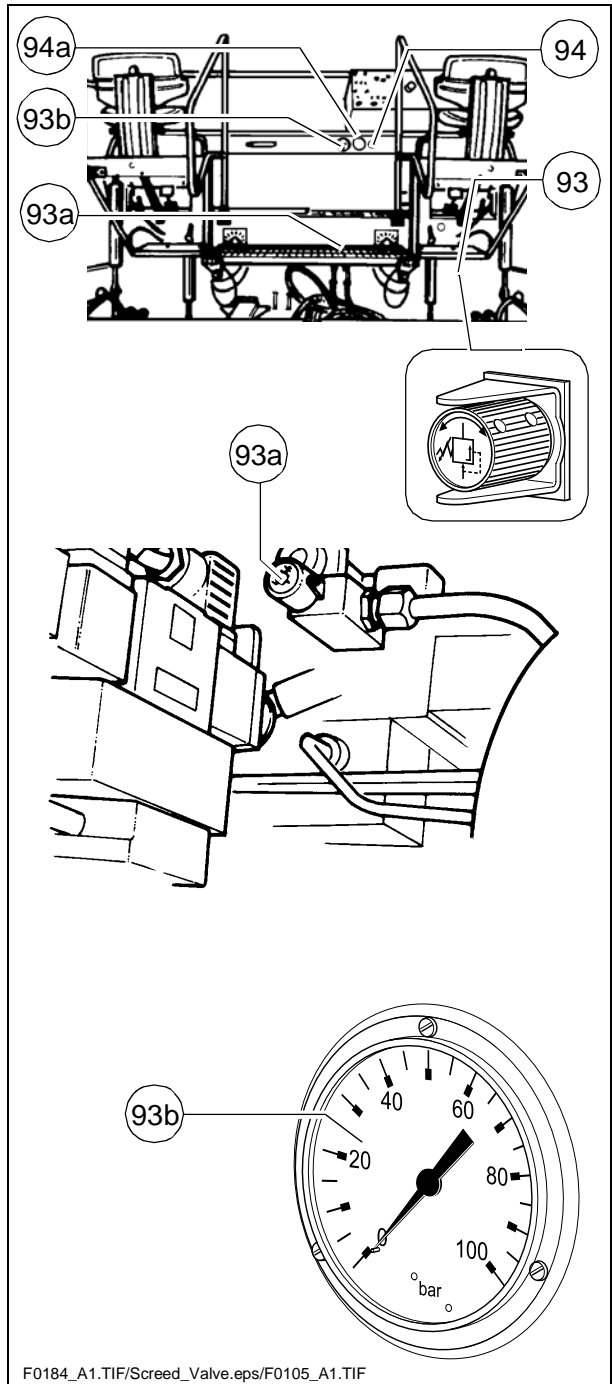

Front wheel drive pressure regulating valve (94) (○)

The drive pressure of the supplementary front wheel drive can be adjusted here.

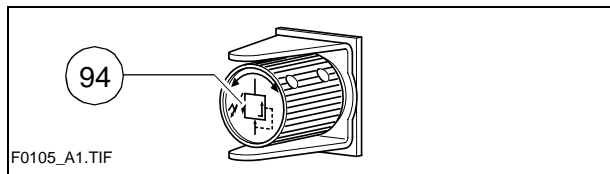

- Engage the front wheel drive with the switch.
- Pressure display: see pressure gauge (94a).

A Adjust the pressure on the moving paver so that the driven front wheels do not spin.

Pressure gauge of the front wheel drive (94a) (○)

It shows the drive pressure of the supplementary front wheel drive.

Pressure adjustment with valve (94)
Experimental value: about 110 - 140 bar
Maximum value: about 200 bar

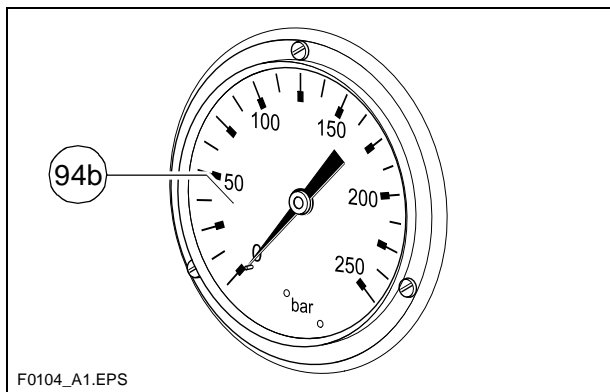

A In case of the engagement of the anti-spin regulator (ASR - o) the optimum value is automatically adjusted to the variable adhesion relations. This requires the adjustment of about 200 bar maximum pressure.

Central lubrication unit (○) (100)

The central lubrication unit turns on in automatic mode when the drive engine starts.

- Pumping time: 12 min
- Duration of the break: 2 h

m

It is prohibited to change the factory-set durations of pumping and break without consulting the technical customer service!

A

Changing the duration of lubrication and breaks may be necessary when placing mineral or cement bound material mix.

Manual start of lubrication (pumping time):

- Remove the cover lid (a).
- Keep the starting button (b) depressed for at least 2 sec.
- Replace the cover lid (a).

A

Observe the instructions of chapter „Maintenance“!

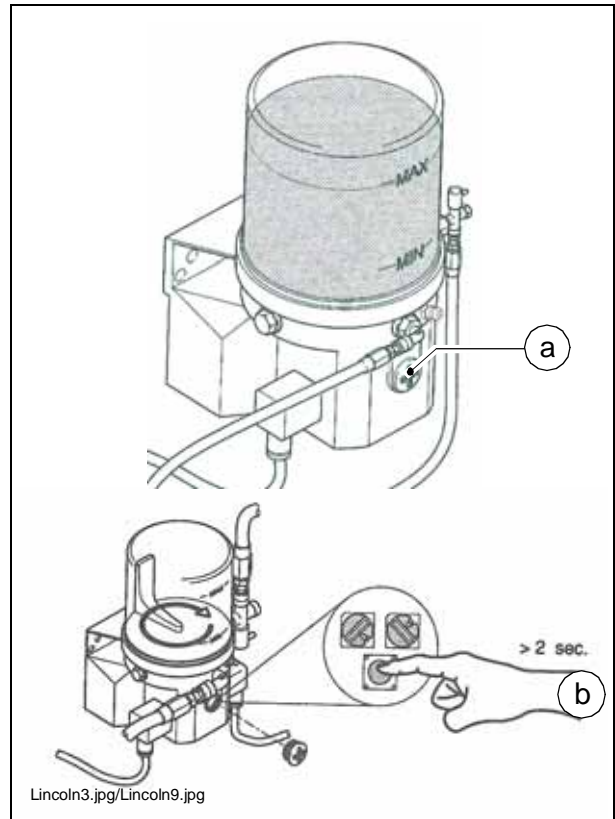

Particle filter - control light (102) (o)

A The control light of the particle filter is found under the control track of the operating panel.

When observing the control light (a) it is essential (a):

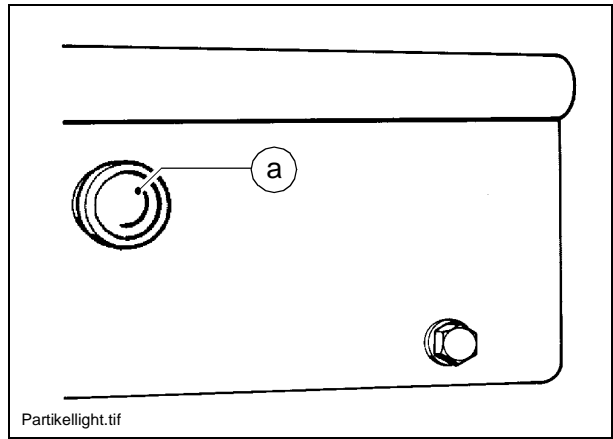

Indicator colour	Operating condition	Cause / action
yellow	No counterpressure	No counterpressure. Check the tightness of the system.
green	Within the measuring range	There is no fault
flashing green	Threshold range - Counterpressure in the warning range	Increase of engine speed to raise the temperature of the exhaust fume.
red	Set value achieved / exceeded	Increase of engine speed to raise the temperature of the exhaust fume. If necessary, clean / replace the particle filter.
flashing red	The temperature or pressure sensor failed	Check and replace, as required, the temperature / pressure sensor

A With the brief increase of the engine speed to the max. range, the filter is cleaned automatically due to the higher temperature of the exhaust fume. If the control light still fails to turn on for this action, the filter needs to be cleaned.

See chapter „Maintenance“ for cleaning the particle filter.

Front and side window (o) (103)

The front window can be folded up for the maintenance works performed at the tank.

- Fold the front window by its handle (A) and lock it on the RH and LH sides with the two locks (B) in the upper position.

Additional functions:

- If necessary, turn on the windscreen wipers on the RH and LH sides (C).
- Fold up the side window (D) at its clevis (window frame) and the push the driver's seat out.

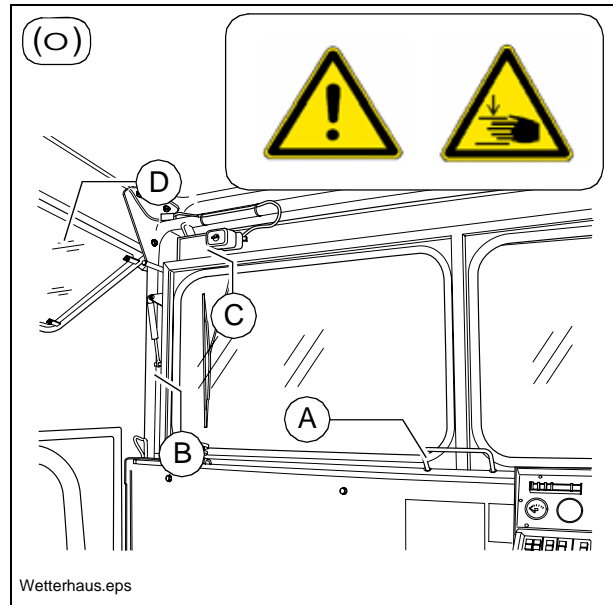

Adjustment of screed eccentric (o) (104)

To pave thicker layers of material, if the piston rods in the levelling cylinder are operating close to their limit position and if the desired paving thickness cannot be reached, it is possible to alter the approach angle of the screen by adjusting the eccentric.

- Pos I: Paving thickness of up to approx. 7cm
- Pos II: Paving thickness of approx. 7 cm to approx. 14cm
- Pos III: Paving thickness above approx. 14 cm

- The spindle (A) is not adjusted.
- Unfasten lock nuts (B) for eccentric adjustment.
- Swivel screed into desired position using lever (C) then engage the locking knob once again.

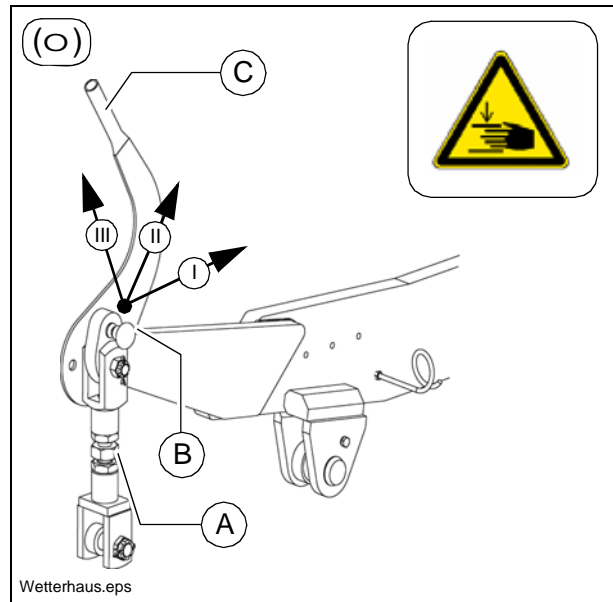

A If the levelling unit is connected to a height controller, this has the function of balancing out any rapid rise in the screed position: The levelling cylinders are extended until the correct height is reached.

A The change in approach angle can only take place slowly and uniformly on both sides at once during paving operation, and involves the use of the eccentric adjustment. Failing this, any rapid response in the screed could easily cause waves to appear on the road surface.

The setting process should therefore take place before work starts!

D4.2 Operation

1 Operation

1.1 Preparation of operation

Required devices and aids

To avoid delays on site, check before starting work whether or not the following devices and aids are present:

- Wheel loader for transporting heavy extendable parts
- Diesel fuel
- Engine oil and hydraulic oil, lubricants
- Separating agents (emulsion) and manual injector
- Two filled propane gas bottles
- Shovel and broom
- Scraper (spatula) for cleaning the auger and the hopper infeed area
- Parts that may become necessary for extending the auger
- Parts that may become necessary for extending the screed
- Percentage spirit level and levelling rail, 4 m long
- Levelling wire
- Protective clothing, signal vest, gloves, ear protection

Before starting work

(in the morning or when starting paving)

- Heed the safety instructions.
- Check the personal protective equipment.
- Take an inspection walk around the paver finisher and check for leaks and damages.
- Install parts removed for transportation or for the night.
- When screed is operated with the optional gas heating system, open the closing valves and the main shut-off valve.
- Perform the check according to the "Checklist for the machine operator" given below.

Checklist for the machine operator

Check!	How?
Emergency stop button - on the operating panel - on both remote control units ○	Push in the button. The diesel engine and all running drives must stop immediately.
Steering	The paver finisher must immediately follow every steering wheel movement in a precise manner. Check straight running.
Horn - on the operating panel - on both remote control units ○	Briefly press the horn button. The horn must sound.
Lights	Switch on with the ignition key, walk around the paver finisher to check and switch off again.
Hazard warning lights of the screed (with vario screeds)	With the ignition switched on, press the switches for extending/retracting the screed parts. The rear lights must flash.
Gas heater system (○): - Bottle holders - Bottle valves - Pressure reducer - Hose break safety devices - Shut-off valves - Main shut-off valve - Connections - Indicator lamps of the switch box	Check: - Secure seat - Cleanliness and tightness - Working pressure 1.5 bar - Function - Function - Function - Tightness - All lamps must light up when the system is switched on

Check!	How?
Auger covers	For larger working widths, the walkway plates must be extended and the auger tunnels must be covered.
Screed covers and walkways	For larger working widths, the walkway plates must be extended. Hinged walkway plates must be swung down. Check that the side shields, the side plates and the covers are securely seated.
Screed transport safeguard	When the screed is lifted, it must be possible to push the locking rods sideways into the recesses in the cross-beams using the lever beneath the seat.
Hopper transport safeguard	When the hopper is closed, it must be possible to fold the catches over the lock studs on the two halves of the hopper.
Protective roof	Both locking bolts must be in the provided bore hole.
Miscellaneous: - Engine hood - Lateral flaps	Check that the hoods and flaps are securely seated.
Accessories: - Wedges - Warning triangle - First-aid kit	The accessories must be in the provided holders.

1.2 Starting the paver finisher

Before starting the paver finisher

Before starting the diesel engine and beginning operation, the following steps must be performed:

- Daily maintenance of the paver finisher (see chapter F)

m Check the operating hour counter to determine whether or not additional maintenance work (such as monthly or yearly maintenance) must be performed.

- Check the safety devices and protective devices.

„Normal“ starting

Set the drive lever (9) to the center position and the speed adjuster (10) to minimum.

- Insert the ignition key (5) in position „0“. The lights should be switched off during starting to reduce the current drain on the battery.

A It is impossible to start the machine, if the drive lever is not in the central position or if one of the emergency stop buttons (7) is depressed. (“STOP“ is seen on the LC display)

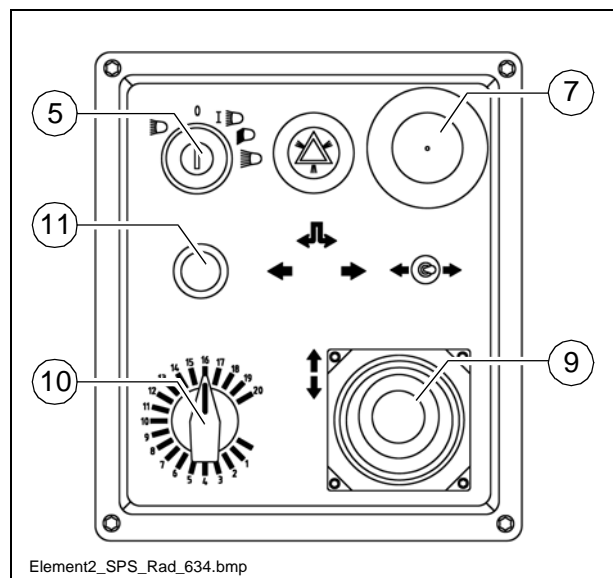

- Press the starter button (11) to start the engine. Do not let the starter run permanently for more than 20 seconds; allow for a break of 1 minute after every attempt.

External starting (starting aid)

- A The engine can be started with the help of an external power source if the batteries are empty and the starter no longer turns.

Suitable power sources are:

- Other vehicles with a 24 V system
- Additional 24 V battery
- Start device that is suitable for external starting (24 V/90 A).

- m Standard chargers or quick chargers cannot be used for external starting.

To externally start the engine:

- Switch on the ignition, set the drive lever (9) to the center position.
- Use appropriate cables to connect the external power source.

Observe the polarity! Always connect the negative cable last and disconnect it first!

- A It is impossible to start the machine, if the drive lever is not in the central position or if one of the emergency stop buttons (7) is depressed.
("STOP" is seen on the LC display)

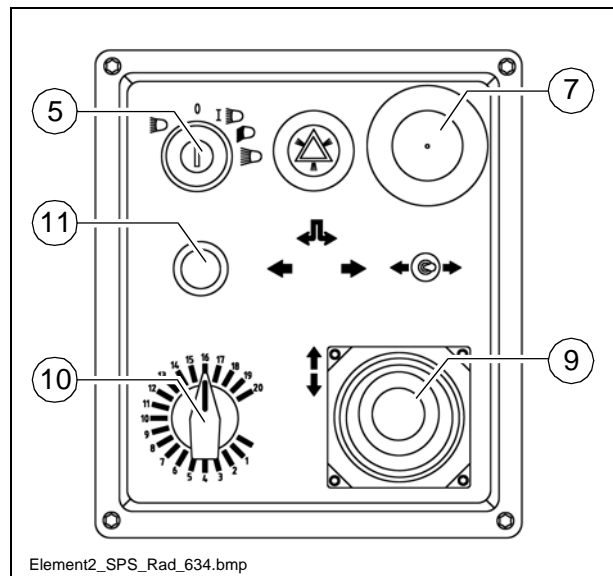

- Press the starter button (11) to start the engine. Do not let the starter run permanently for more than 20 seconds; allow for a break of 1 minute after every attempt.

When the engine is running:

- Disconnect the power source.

After starting

To increase the engine speed:

- Set the drive lever (9) to position 1 (slightly off the center position).
- Increase the engine speed by pressing button (21) on the operating panel. The engine speed will be increased to the preselected value.

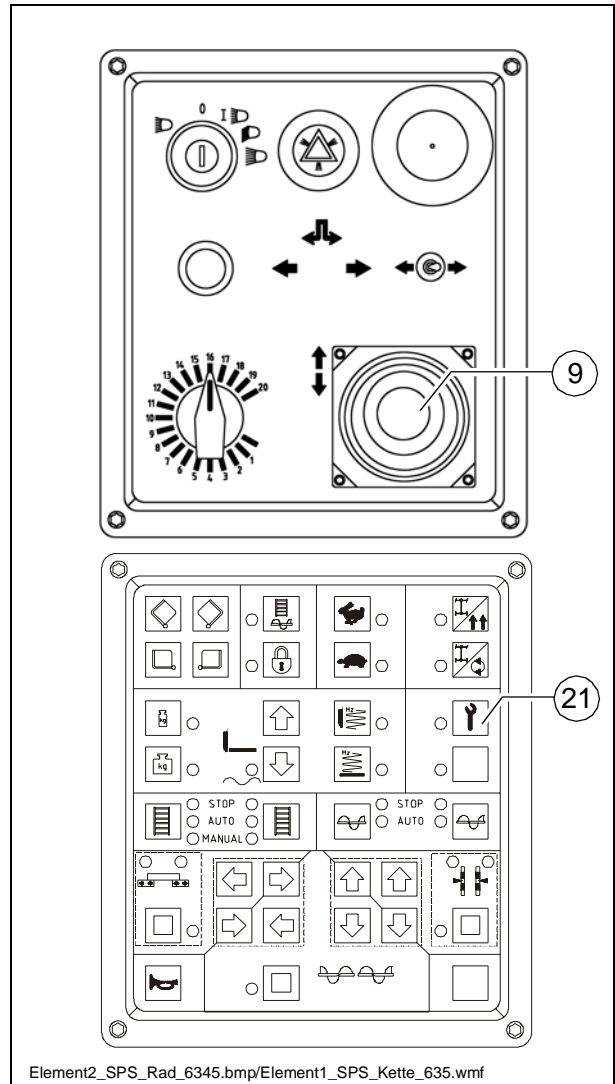

- m Let the paver finisher warm up for ca. 5 minutes if the engine is cold. For this change the two-stage transmission (3) to neutral.

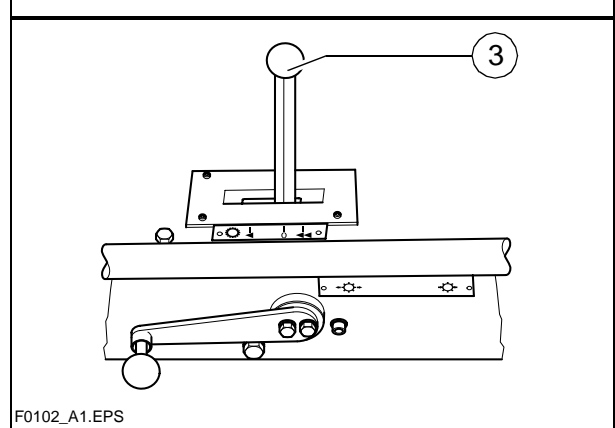

Indicator lamps

The following indicator lamps must be observed under all circumstances:

For further possible faults, refer to the operating instructions for the engine.

Oil pressure indicator lamp for the traction drive (46)

- Must go out after starting.

m

If the lamp does not go out: Do not switch on the traction drive! Otherwise, the entire hydraulic system could be damaged.

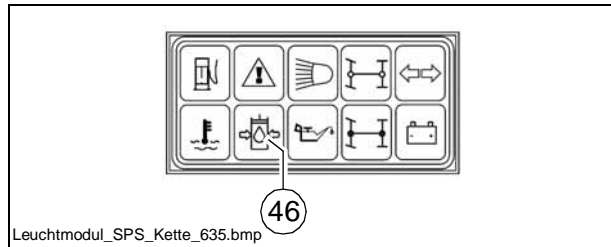

When the hydraulic oil is cold:

- Set the conveyor switch (32) to „manual“ and the auger switch (24) to „auto“.
- The remote control has to be connected and the same function have to be set to „auto“
- Set the drive lever (9) to position 1
- Press button (21) to increase the engine speed, the conveyor and the auger start operating.
- Let the hydraulics warm up until the indicator lamp goes out.

A

The lamp goes out when the pressure drops below 2.8 bar = 40 psi.

For further possible malfunctions, refer to section 4.

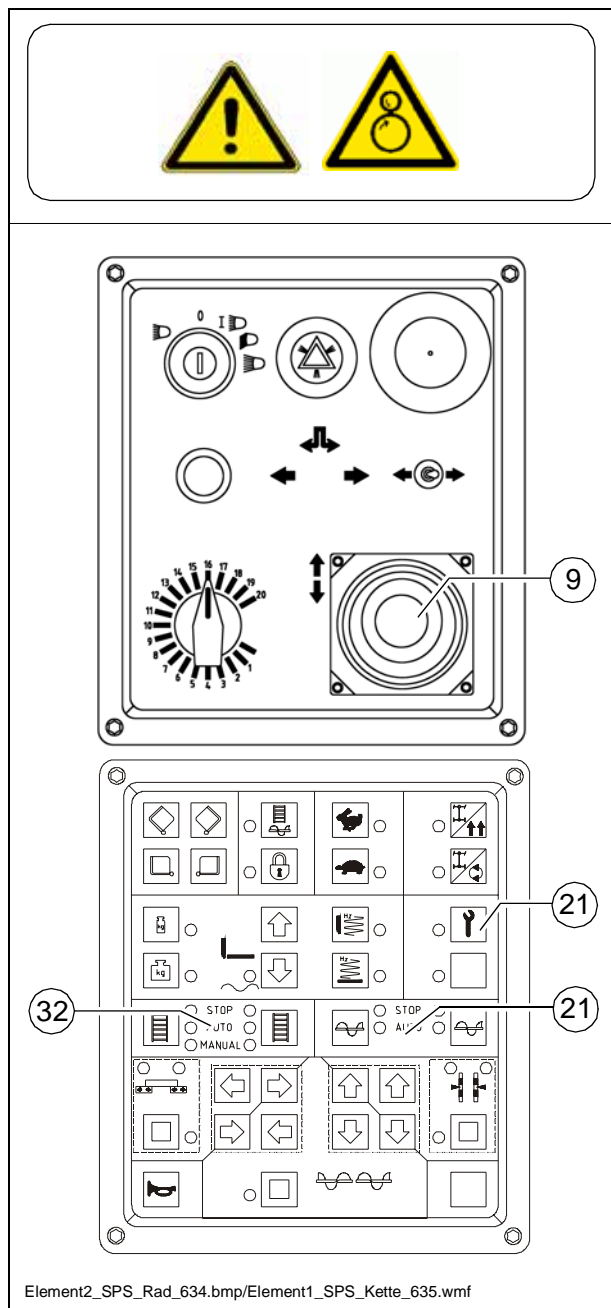

Battery charge indicator (49)

Must go out after starting when the engine revs up.

m

Briefly rev up the engine when the lamp does not go out or lights up during operation.

Switch off the engine and determine the cause for the malfunction if the lamp does not go out.

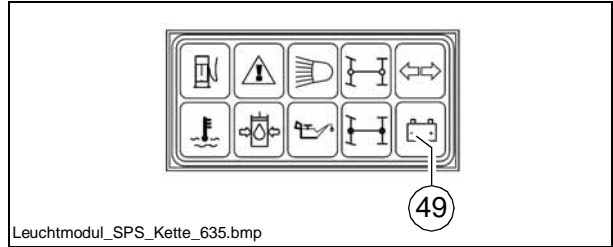

1.3 Operation in case of transportation

Lifting and securing the screed

- Button (16) has to be switched off
- Switch off the buttons (34) and lift the screed full by using button (33).
- Extend the levelling cylinders full by using the buttons (25) and (27).
The remote control has to be connected and the same function has to be set to „manual“.
- Lift the auger crossbeam by using the buttons (28) and (27)
- Insert the screed transport safeguards (74).

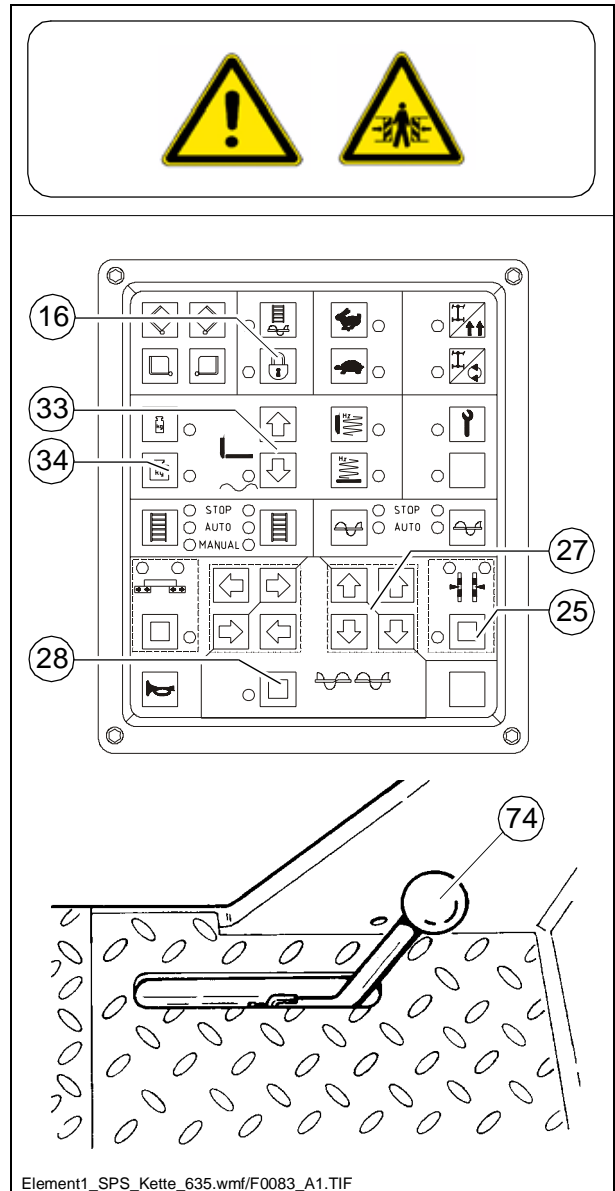

Driving and stopping the paver finisher

- Set the Fast/Slow switch (17) to „Hare“.
- Set the preselector traction drive (10) to mark 10
- For driving, carefully tilt the drive lever (9) forward or backward according to the drive direction desired.

f In case of an emergency, press the emergency stop button (7)!

- To stop the paver finisher, set the drive lever (9) to the center position.

Switching off and securing the paver finisher

- Turn the ignition key (5) to the „0“ position and pull it out to switch off the engine.

m The battery can get exhausted if the paver finisher is standing still for longer periods of time with the ignition switched on.

- Lower the screed.

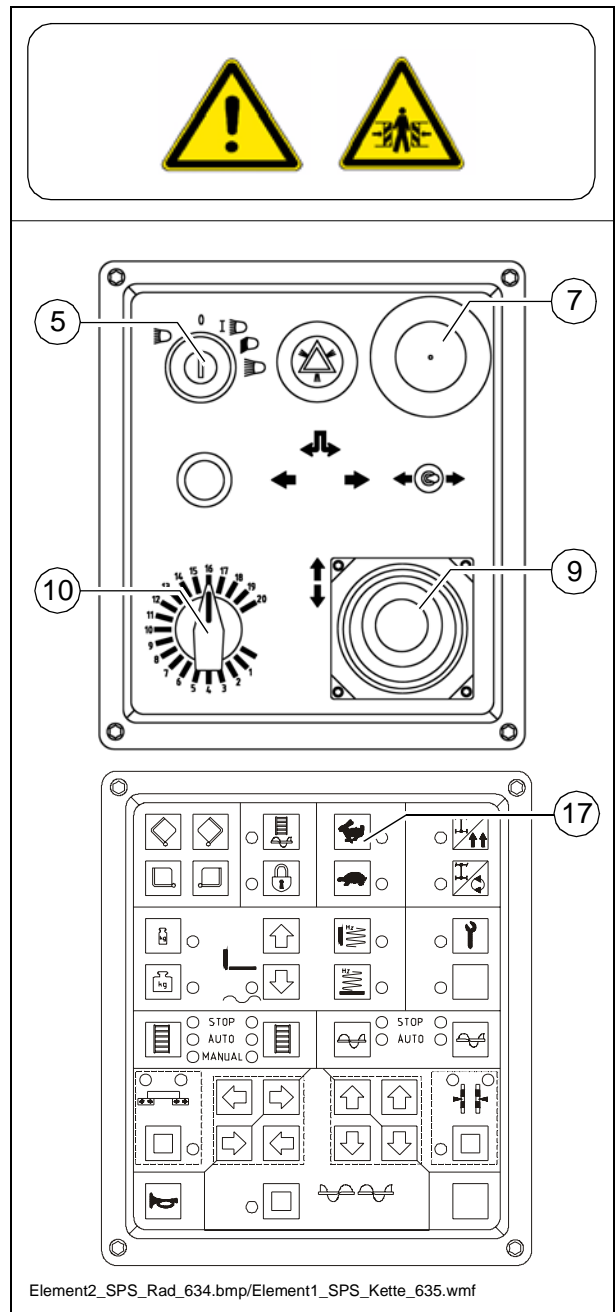

1.4 Preparations for paving

Separating agent

Spray the parts coming into contact with asphalt (hopper, screed, auger, push roller) with a separator emulsion.

- m Do not use diesel fuel as it dissolves the bitumen (prohibited in Germany!).

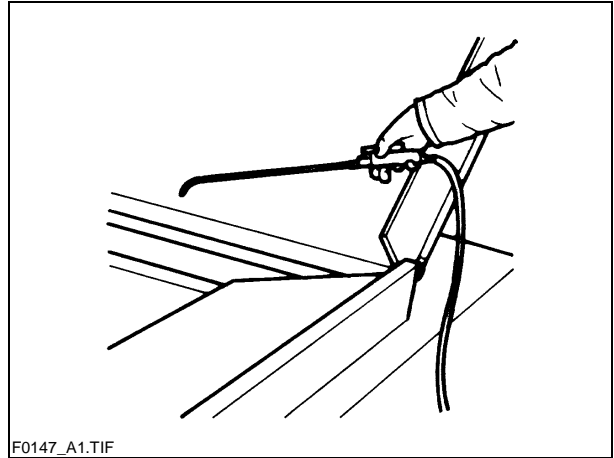

F0147_A1.TIF

Screed heater

Switch on the screed heater ca. 15–30 minutes (depending on the ambient temperature) before paving begins. Warming up prevents the material from sticking to the screed plates.

Direction marks

To ensure straight paving, a direction mark must be present or established (road edge, chalk lines or similar).

- Slide the operating panel to the desired side and secure it.
- Pull the direction indicator out of the bumper (arrow) and adjust it accordingly.

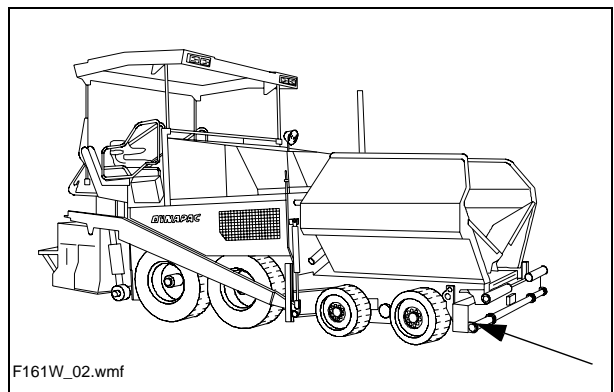

F161W_02.wmf

Loading/distributing material

- Button (16) has to be switched off.
- Use switch (13) to open the hopper. Instruct the truck driver to dump the material.
- Set the switches for the auger (24) and the conveyor (32) to „auto”.
- Press button (15) to fill the machine for paving.

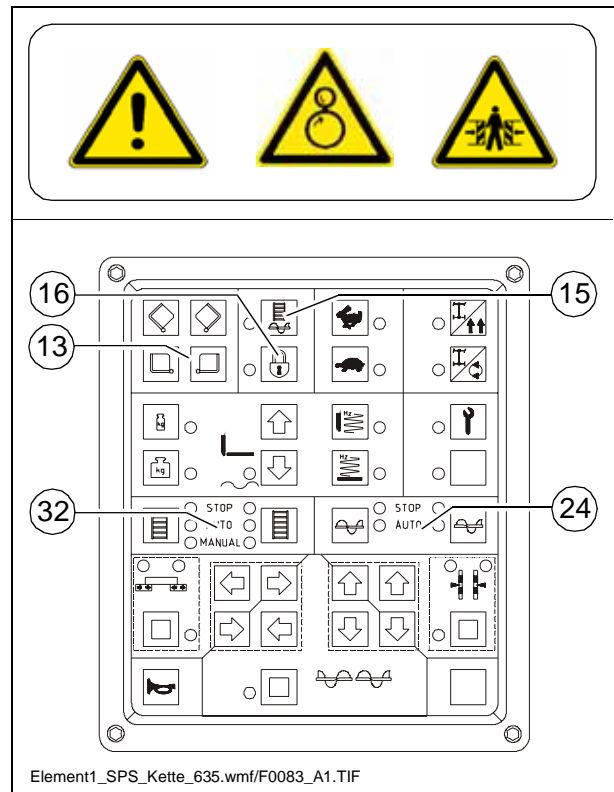

- Switch the conveyors on.
The limit switches for the conveyors (89) or (89a) must switch off when the material has reached the area beneath the auger crossbeam.
- Check that the material is conveyed properly.
Manually switch on or off the conveyor if the material is not conveyed properly until a sufficient amount of material lies in front of the screed.

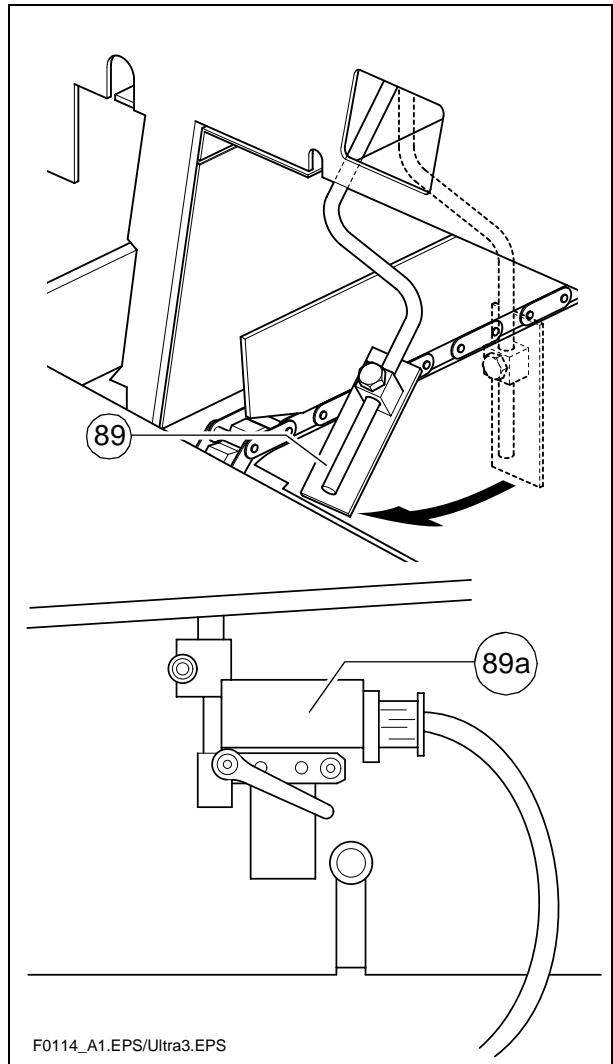

1.5 Starting for paving

C

A

B

Element2_SPS_Rad_634.bmp/Element1_SPS_Kette_635.wmfr/Tamprev.cdr/Vibrev.cdr/Remote_SPS_neu1cdr

Set the switches, levers and controls listed below to the specified positions when the screed has reached its operating temperature and a sufficient amount of material lies in front of the screed:

Item	Switch	Position
17	Machine travel fast / slow	slow („Tortoise“)
C	Travel / work gears	Work gear (◀)
10	Preselector traction drive	Mark 6-7
33	Preparation for screed floating position	LED ON
23	Vibration	LED ON
20○	Tamper	LED ON
24/56	Auger left/right	Auto
32/54	Conveyor left/right	Auto
51	Levelling	Auto
A	Speed regulator, vibration	ca. mark 40-60
B	Speed regulator, tamper	ca. mark 40-60

- Push the drive lever (9) all the way to the front and start driving. Screed floating position is activated now.
- Observe the distribution of the material and adjust the limit switches if necessary.
- Set the compacting elements (tamper and/or vibration) according to the required compaction ratio.
- Let the paving master check the layer thickness after 5–6 meters and correct if necessary.

Carry out the check in the area of the drive chains or wheels as the screed tends to level an uneven ground. The reference points for the layer thickness are the drive chains or wheels.

The basic setting of the screed must be corrected when the actual layer thickness deviates significantly from the values indicated by the scales (see the operating instructions for the screed).

A The basic setting is for asphalt material.

1.6 Checks during paving

The following points must be constantly observed during paving:

Paver finisher function

- Screed heater
- Tamper and vibration
- Engine oil and hydraulic oil temperature
- The screed parts must be retracted and extended in time when obstacles are in the way
- Uniform material transport and distribution or supply to the screed; may require corrections to settings of the material switches for conveyor and auger.

A See the section "Malfunctions" when paver finisher functions fail.

Quality of the layer

- Layer thickness
- Slope
- Evenness in the driving direction and at right angles to it (check with 4 m levelling rod)
- Surface structure/texture behind the screed.

A See section 4 "Malfunctions, Problems during Paving" if the paving quality is poor.

1.7 Paving with screed stop and screed charging/relieving

General

The screed hydraulics can be influenced in two ways to attain optimum paving results:

- Screed stop with and without pretensioning with the paver finisher halted,
- Screed charging or relieving with the paver finisher driving.

A Relieving reduces the screed weight and increases the traction force. Charging increases the screed weight, reduces the traction force, but increases the compaction ratio. (To be used with light-weight screeds in exceptional cases.)

Screed charging/relieving

This function charges or relieves the screed regardless of its own dead weight.

Switch (34) has the following positions:

- A:** Relieving (screed 'lighter')
- B:** Charging (screed 'heavier')

Switch positions „Screed charging/relieving” are only effective when the paver finisher moves. When the paver finisher stops, „screed stop” is automatically selected.

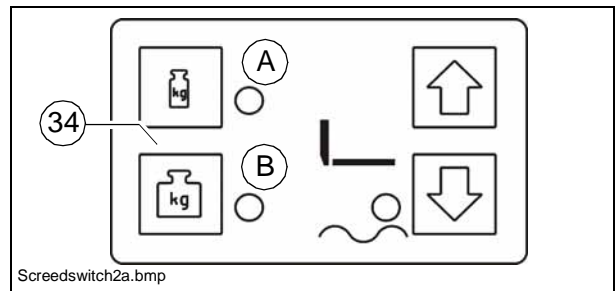

Screed stop with prestressing

With the „Screed stop" function it is possible to block the hydraulic system of the screed, which stops the sinking of the screed in case of temporary stopping.

Switch (34) must be turned off.

- Automatic screed stop when the drive lever is in the center position
- To lift the screed press button (33A).
- For lowering the screed press button (33B) for 1.5 sec.

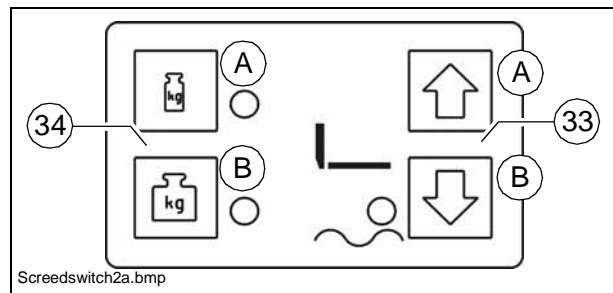

m

Position (B) is not a sufficient security for transportation or maintenance operations!

The transportation safeguard of the screed must also be inserted for this.

Screed stop with prestressing

As for charging/relieving, a pressure of 2-50 bar can be individually applied to the screed lifting cylinders. This pressure can neutralize the weight of the screed to prevent the screed from sinking into the freshly laid material, thus supporting the screed stop function, especially in those situation where the screed relieving function is used.

The pressure to be applied depends on the load-bearing capacity of the material. If necessary, the pressure must be readjusted or changed as required during the first stops until the lower edge of the screed no longer leaves any marks when the paver finisher moves on again.

A pressure greater than 10-15 bar neutralizes the screed weight, thus preventing the screed from sinking into the material.

A

When combining the "screed stop" and "screed relieving" functions, make sure that the pressure difference between the two functions does not exceed 10-15 bar.

Especially in those cases where the "screed relieving" function is only briefly used as a start-up aid, there is a danger of uncontrolled floating when starting up again.

A

If paving is performed with „screed charging“ **do not** use the function „stopping of screed with pretensioning“.

Adjusting the pressure (○)

Pressure adjustments can only be made while the diesel engine is running. Therefore:

- Start the diesel engine and set the traction controller (10) to zero (precaution against inadvertent advancing).
- Set switch (33) to the floating position.
- Set the drive lever (9) to the center position.
- Set switch (16) to position (LED OFF) and switch (21) to position (LED OFF).
- Use control valve (93a) (below the bottom plate of the operator's platform) to adjust the pressure and read it from the manometer (93b). (Basic setting: 20 bar)

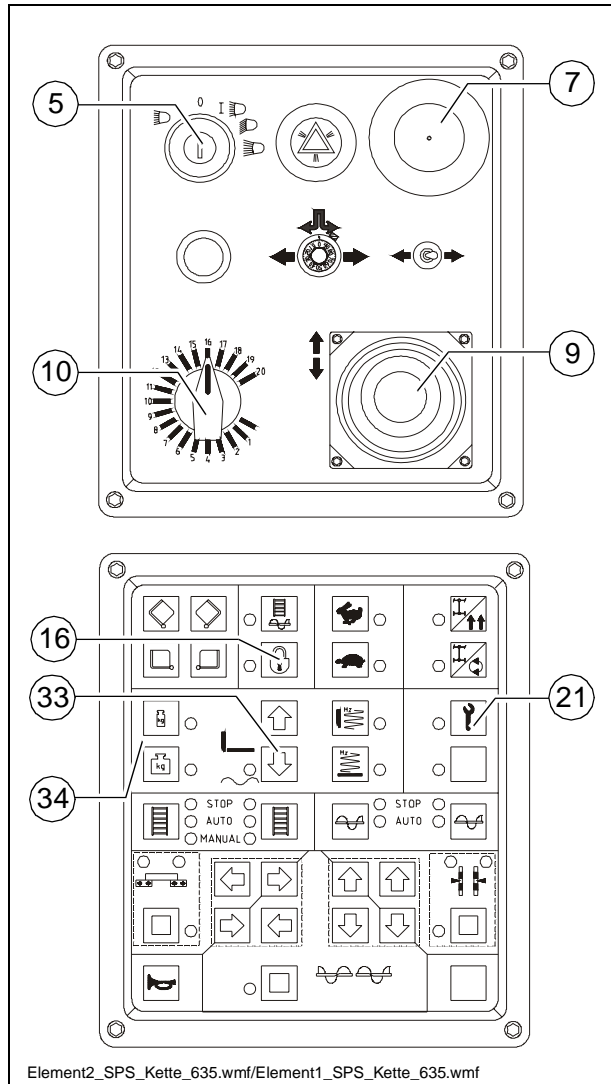

For screed charging/relieving:

- Set the drive lever (9) to the center position.
- Set switch (16) to position (LED OFF) and switch (21) to position (LED ON).
- Set switch (34) to position (LED ON) (relieving 34a) or (charging 34b).
- Adjust the pressure with the regulating valve (93) (at the rear of the paver finisher) and read the value on the pressure gauge (93b).

A When screed charging/relieving is necessary and automatic levelling is used (grade control and/or slope control), the compacting performance changes (layer thickness).

A The pressure can also be set or corrected during paving. (max. 50 bar)

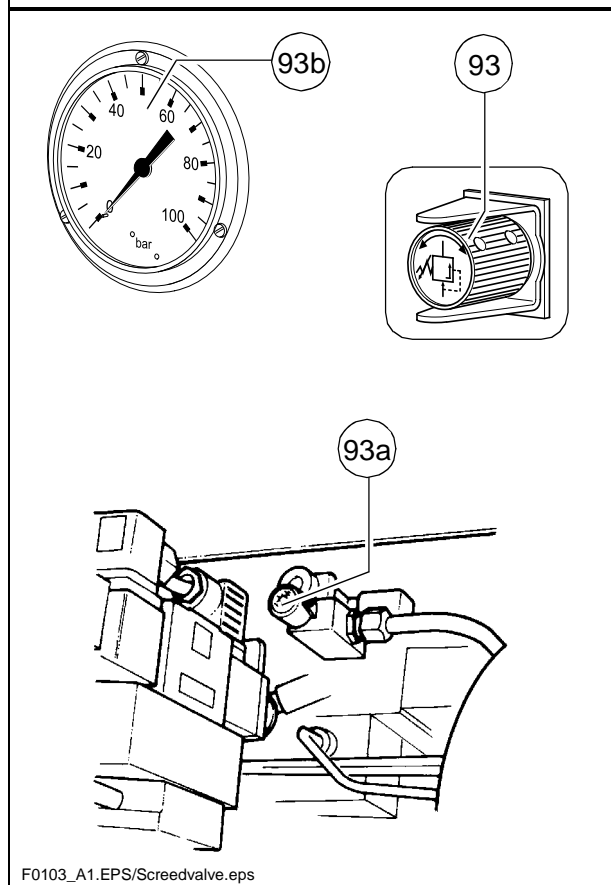

1.8 Interrupting/terminating operation

During breaks: (e.g. the material supply truck is late)

- Determine the approximate duration.
- When cooling down of the material below the minimum paving temperature must be expected, run the paver finisher empty and create an edge like the end of a layer.
- Set the drive lever (9) to the center position.

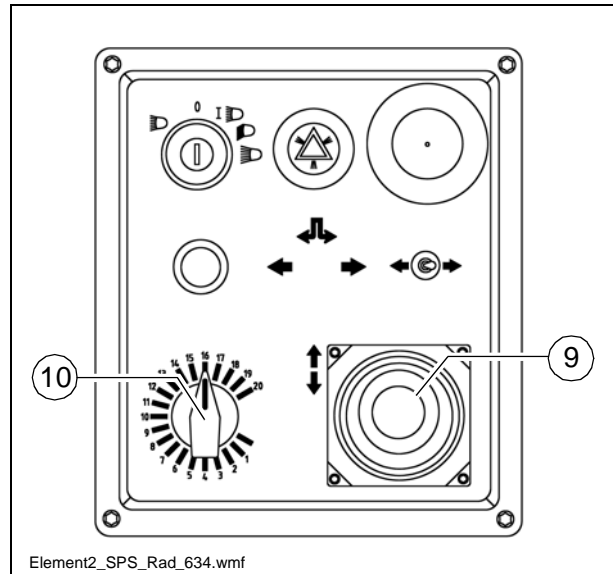

During extended interruptions
(e.g. lunch break)

- Drive lever (9) into centre position, RPM speed adjustment (10) to minimum position.
- Switch off ignition.
- Switch off screed heater (system).
- When screed is operated with the optional gas heating system, close the valves of the bottles.

A The screed must be heated up to the correct paving temperature before paving may be restarted.

When work is finished

- Run the paver finisher empty and stop it.
- Lift the screed by using button (33).
- Retract the screed parts to the basic screed width and lift the auger. Where applicable, completely extend the levelling cylinders.

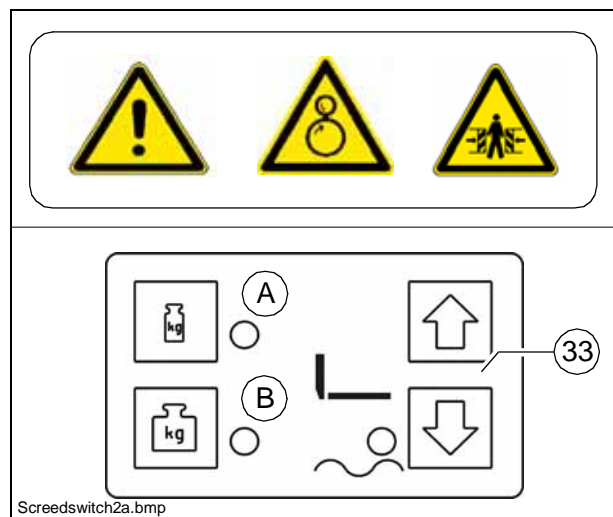

- Insert the mechanic screed transport safeguard (74) on both screed lifting cylinders.
- While operating the tampers at a low speed, let any material residues drop out.

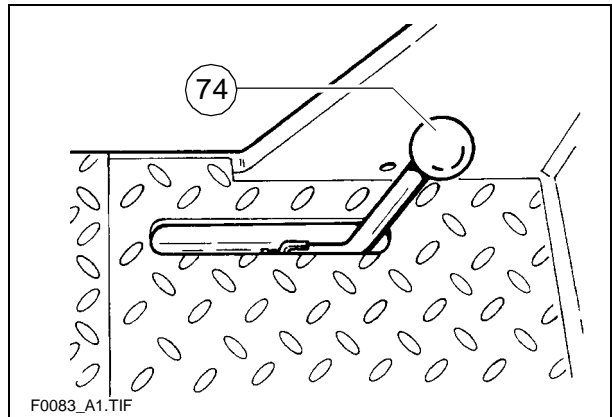

F0083_A1.TIF

- Set the drive lever (9) to the center position and the speed adjuster (10) to minimum
- Switch off the ignition (5).
- Switch off screed heater (system).
- When screed is operated with the optional gas heating system, close the main shut-off valves and the valves of the bottles.
- Remove the levelling units and stow them away in the boxes, close all flaps
- Remove all parts that extend beyond the paver finisher contour or secure them if the paver finisher is to be transported over public roads on a low-bed trailer.

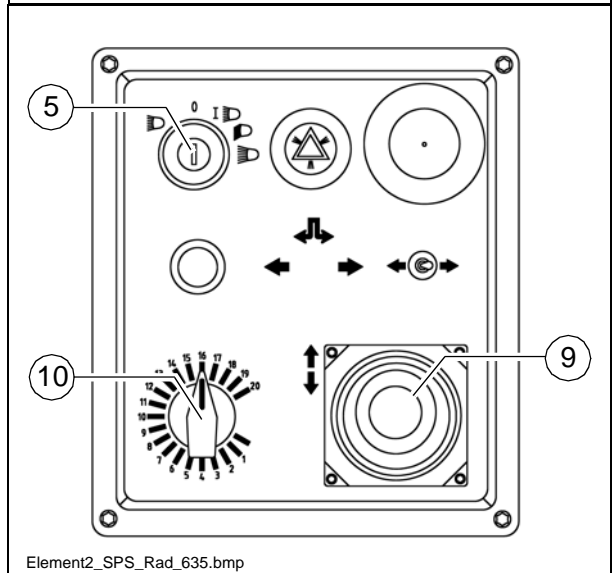

Element2_SPS_Rad_635.bmp

m Do not turn off main switch until 15 seconds after the ignition has been turned off!

A The engine electronics need this length of time to back up data.

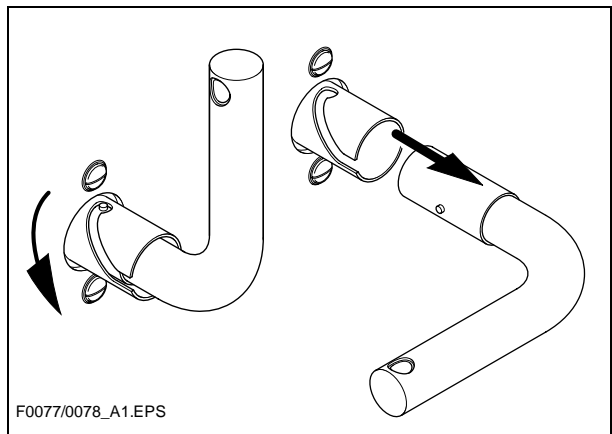

F0077/0078_A1.EPS

- Read and check the operating hour meter to determine whether maintenance work must be performed (see chapter F).
- Cover and lock the operating panel.
- Remove material residues from the screed and the paver finisher and spray all parts with separator fluid.

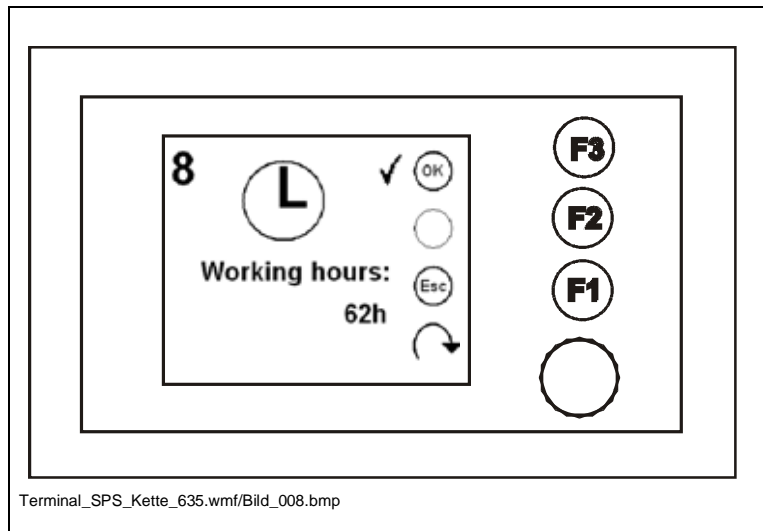

2 Special functions

2.1 Electro-hydraulic differential lock

Engaging the differential lock:

- Change switch (19) to position „On“ (the LED is lit up).
- Keep button (29a) depressed until the control light (48) starts to light up.

Disengaging the differential lock:

- Change the switch (19) to position „On“ (the LED is lit up).
- Keep button (29b) depressed until the control light (48) goes dark.

A The differential lock must be used in case of grip problems (loose ground). The differential lock can be engaged during travel.

m Do not turn with the differential lock engaged and the screed lifted. The differential gear may get damaged.

Do not use the differential lock when travelling. There is a risk of accident due to the restricted possibility of steering!

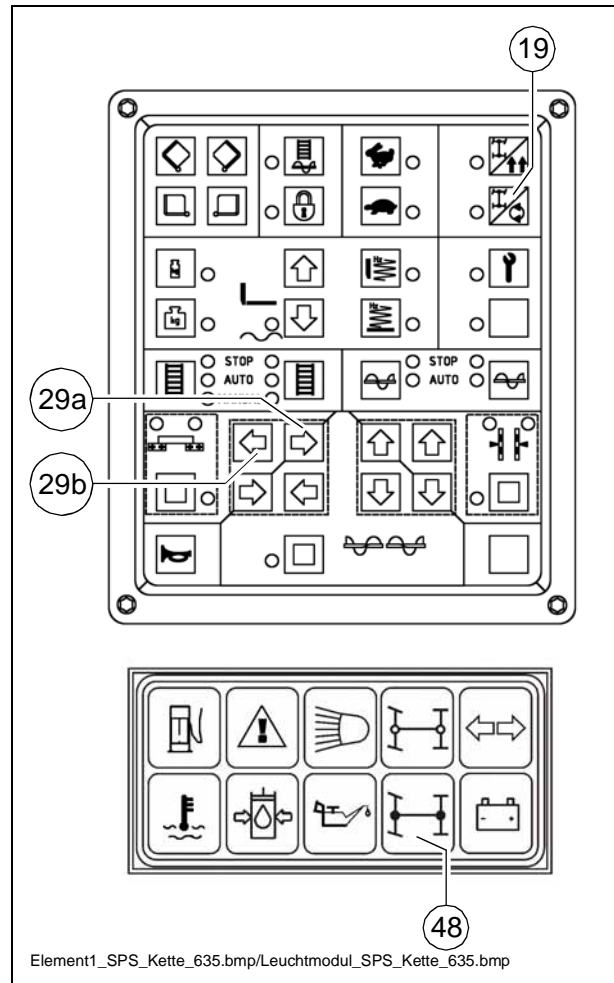

2.2 Electro-hydraulic selection of gears

The transmission can be switched to three gears:

- ◀ = working gear
- 0 = neutral
- ◀◀ = travel gear

Changing to working gear:

- Change the switch (22) to position „On“ (the LED is lit up).
- Keep button (29a) depressed until the control light (a) starts flashing.

Changing to travel gear:

- Change the switch (22) to position „On“ (the LED is lit up).
- Keep button (29b) depressed until the control light (b) starts flashing.

Changing to neutral:

- Change the switch (22) to position „On“ (the LED is lit up).
- Keep button (29a) or (29b) depressed until the control lights (a)/(b) start flashing.

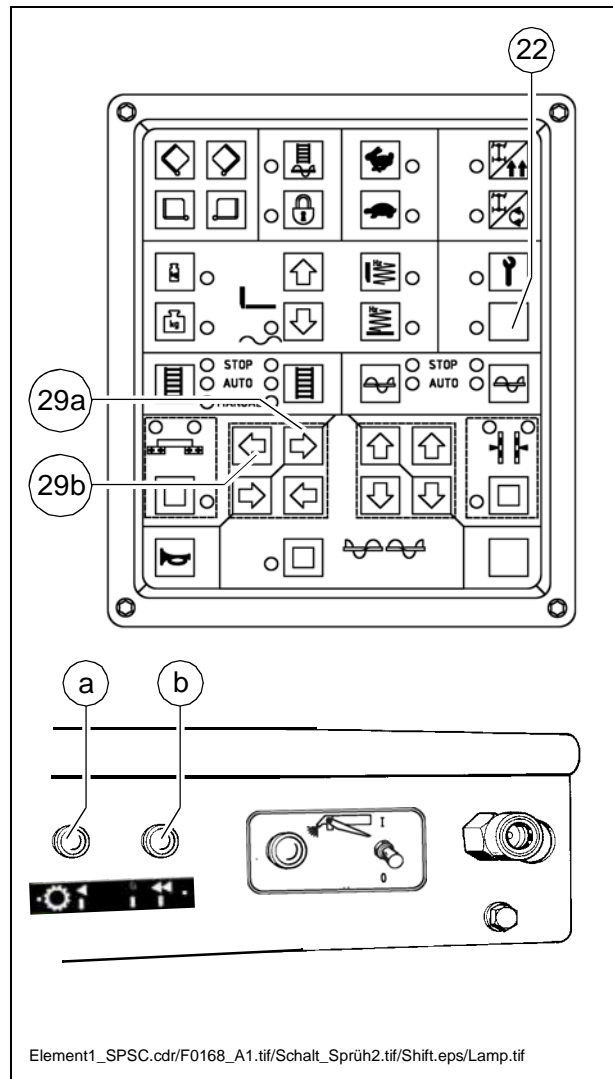

m Before changing apply the parking brake. Engage the gears only at standstill!

- When the gear cannot be selected, mover the drive lever slightly.

m When towing the paver finisher (e.g. the Diesel engine failed) use the neutral gear. Otherwise, the transmission may fail.

Including the Rabbit / Tortoise gears the drive lever can be changed to 4 different speeds:

Combination	Use
◀ 🐢	Slow laying speed
◀◀ 🐢	Slow travel speed
◀ 🐇	Fast laying speed
◀◀ 🐇	Fast travel speed

3 Malfunctions

3.1 Problems during paving

Problem	Cause:
Wavy surface ("short waves")	<ul style="list-style-type: none"> - change in the material temperature, demixing - wrong material composition - incorrect operation of the roller - incorrectly prepared foundation - long standstill times between loads - grade control reference line is not suitable - grade control jumps to the reference line - grade control toggles between up and down (inertia setting is too high) - bottom plates of the screed are loose - bottom plates of the screed are warped or not uniformly worn - screed does not work in the floating position - too much play in the mechanical screed link/suspension - paver finisher speed is too high - augers are overloaded - changing material pressure against the screed
Wavy surface ("long waves")	<ul style="list-style-type: none"> - change in the material temperature - demixing - roller has stopped on the hot material - roller has turned or roller speed has been changed too fast - incorrect operation of the roller - incorrectly prepared foundation - truck brake is applied too tight - long standstill times between loads - grade control reference line is not suitable - incorrect installation of the grade control - limit switch is not correctly set - screed is empty - screed has not been switched to the floating position - too much play in the mechanical screed link - auger is set too deep - auger is overloaded - changing material pressure against the screed
Cracks in the layer (over the entire width)	<ul style="list-style-type: none"> - material temperature is too low - change in the material temperature - moisture on the foundation - demixing - wrong material composition - wrong layer height for the maximum grain size - cold screed - bottom plates of the screed are worn or warped - paver finisher speed is too high
Cracks in the layer (center strip)	<ul style="list-style-type: none"> - temperature of the material - cold screed - bottom plates are worn or warped - wrong crowning

Problem	Cause:
Cracks in the layer (outer strip)	<ul style="list-style-type: none"> - temperature of the material - screed extendable parts are incorrectly installed - limit switch is not correctly set - cold screed - bottom plates are worn or warped - paver finisher speed is too high
Layer composition is not uniform	<ul style="list-style-type: none"> - temperature of the material - change in the material temperature - moisture on the foundation - demixing - wrong material composition - incorrectly prepared foundation - wrong layer height for the maximum grain size - long standstill times between loads - vibration is too slow - screed extendable parts are incorrectly installed - cold screed - bottom plates are worn or warped - screed does not work in the floating position - paver finisher speed is too high - auger is overloaded - changing material pressure against the screed
Marks in the surface	<ul style="list-style-type: none"> - truck hits too much against the paver finisher while aligning to the paver finisher - too much play in the mechanical screed link/suspension - truck brake is applied - vibration is too high while standing on a spot
Screed does not react to corrective measures as expected	<ul style="list-style-type: none"> - temperature of the material - change in the material temperature - wrong layer height for maximum grain size - incorrect installation of the grade control - vibration is too slow - screed does not work in the floating position - too much play in the mechanical screed link - paver finisher speed is too high

3.2 Malfunctions on the paver finisher or screed

Malfunction	Cause:	Remedy
At the diesel engine	Diverse	See operating instructions for the engine
Diesel engine does not start	Batteries empty	See "External starting" (start assistance)
	Diverse	see "Towing"
Tamper or vibration does not operate	Tamper is obstructed by cold bitumen	Properly heat the screed
	Hydraulic oil level in the tank is too low	Top up the oil
	Pressure limiting valve is defective	Replace the valve; if necessary, repair and adjust the valve
	Leak in the suction line of the pump	Seal or replace the connections
		Tighten or replace the hose clamps
Oil filter is soiled	Clean the filter; if necessary, replace the filter	
Conveyor or augers run too slowly	Hydraulic oil level in the tank is too low.	Top up the oil
	Power supply is interrupted	Check fuses and cables; replace if necessary
	Switch is defective	Replace the switch
	One of the pressure limiting valves is defective	Repair or exchange the valves
	Pump shaft broken	Replace the pump
	Limit switch does not switch or regulate correctly	Check the switch; replace and adjust the switch if necessary
	Pump is defective	Check the high pressure filter for dirt particles; replace if necessary
	Oil filter is soiled	Replace the filter
Hopper cannot be swung open	Engine speed is too low	Increase the speed
	Hydraulic oil level is too low	Top up the oil
	Leak in the suction line	Tighten the connections
	Flow rate regulator defective	Replace
	Leaking seals of the hydraulic cylinder	Replace
	Control valve is defective	Replace
	Power supply interrupted	Check fuse and cables; replace if necessary

Malfunction	Cause:	Remedy
Hoppers lowers inadvertently	Control valve is defective	Replace
	Leaking seals of the hydraulic cylinder	Replace
Screed cannot be lifted	Oil pressure too low	Increase the oil pressure
	Leaking seal	Replace
	Screed relieving or charging is switched on	Switch must be in the center position
	Power supply is interrupted	Check fuse and cables; replace if necessary
Crossbeams cannot be lifted or lowered	Switch on the remote control is set to "auto"	Set the switch to "manual"
	Power supply is interrupted	Check fuse and cables; replace if necessary
	Switch on the operating panel defective	Replace
	Excess pressure valve defective	Replace
	Flow rate regulator defective	Replace
	Seals defective	Replace
Crossbeams lower inadvertently	Control valves defective	Replace
	Pilot-controlled non-return valves defective	Replace
	Seals defective	Replace

Malfunction	Cause:	Remedy
Traction does not work	Traction drive fuse defective	Replace (Fuse holder on the operating panel)
	Power supply is interrupted	Check potentiometer, cables, connectors; replace if necessary
	Traction drive monitoring (type-specific) defective	Replace
	Electro-hydraulic servo unit of the pump defective	Replace the servo unit
	Insufficient supply pressure	Check and adjust if necessary
		Check the suction filter; replace the supply pump and the filter if necessary
Drive shaft of hydraulic pumps or engines broken	Replace pump or engine	
Irregular engine speed, engine stop function does not work	Fuel level too low	Check the fuel level; refill fuel if necessary
	Fuse "engine speed control" defective	Replace (fuse strip on the operating panel)
	Defective power supply cables (cables broken or short-circuited)	Check potentiometer, cables, connectors; replace if necessary

E 01 Set-up and modification

1 Special notes on safety

f Danger to personnel by inadvertent starting of the engine, the traction drive, the conveyor, the auger, the screed or the lifting units. Unless specified otherwise, work may only be performed when the engine is at a standstill!

- To protect the paver finisher against inadvertent starting:
Set the drive lever to the center position and set the preselector to zero; if applicable, remove the drive traction fuse from the operating panel; pull out the ignition key and the battery main switch.
- Secure lifted machine parts (e.g. screed or hopper) against lowering by means of mechanical supports.
- Replace parts or have them replaced as stipulated.

f When connecting or disconnecting hydraulic hoses and when working on the hydraulic system, hot hydraulic fluid can spurt out at a high pressure. Switch off the engine and de-pressurize the hydraulic system! Protect your eyes!

- Mount all protective devices before re-commissioning the paver finisher.
- The walking platform must always reach over the entire width of the screed. The hinged walkway (option for all variable screeds) may only be swung up under the following circumstances:
 - When paving next to a wall or a similar obstacle.
 - During transportation on a low-bed trailer.

2 Auger

2.1 Height adjustment

Depending on the mix of materials, when working with layer thicknesses of up to 15 cm, the height of the distribution auger (1) – measured from its bottom edge – should be around 5 cm (2 inches) above the material layer thickness (depending on its mix of materials).

Example: Layer height 10 cm
Adjustment: 15 cm from the ground

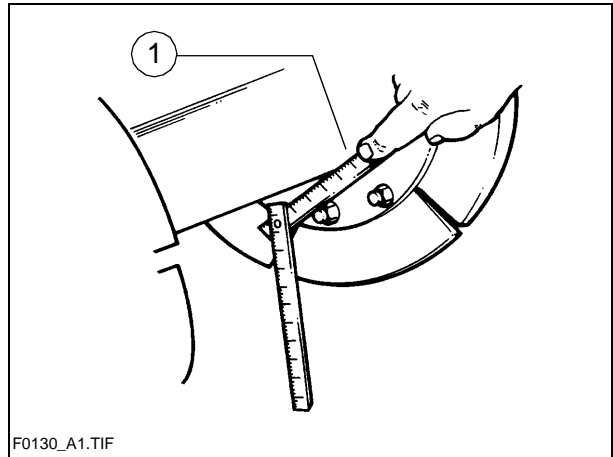

An incorrect height adjustment can result in the following problems:

- Auger too high:
Too much material in front of the screed; material overflow. When operating with larger widths, demixing and traction problems may occur.
- Auger too low:
Not enough material that can be precompactd by the auger. Irregularities resulting from this cannot be completely compensated for by the screed (wavy surface). In addition, an increased wear on the auger segments occurs.

2.2 Auger crossbeam installed in a fixed position

- Lower the screed onto a suitable support (e.g. squared timbers).
- Completely extend both levelling cylinders.
- Hook lifting chains (2) for lifting the auger crossbeam into the hooks of the crossbeams.
- Loosen the fixing screws (3) of the auger crossbeam.
- Retract the levelling cylinders until the auger crossbeam has reached the desired height.
- Tighten the fixing screws (3) of the auger crossbeam.

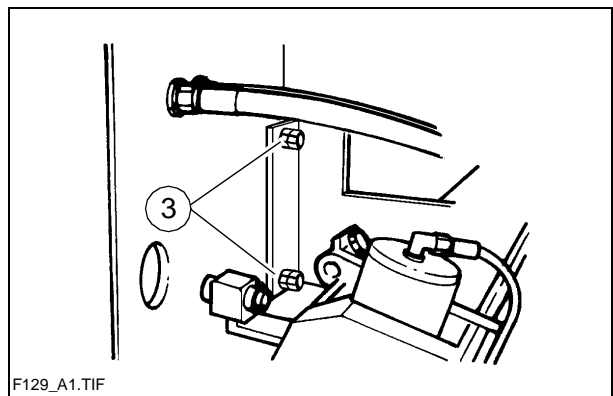
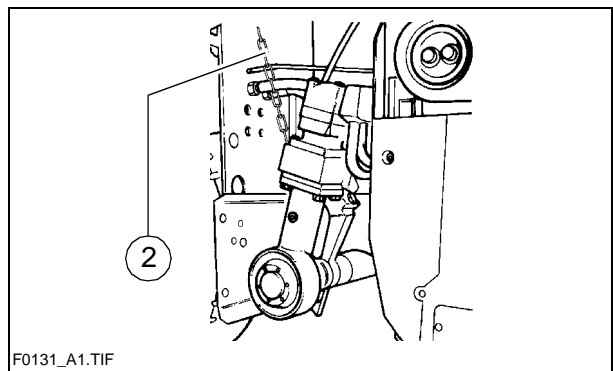

2.3 Mechanical adjustment with ratchet (optional)

- Set the ratchet direction lever to clockwise or anticlockwise direction. Turning anticlockwise lowers the auger, turning clockwise lifts the auger.
- Set the desired height by alternatingly adjusting the right-hand and the left-hand side.
- The actual height can be read on scale (1) in cm or inch (LH side column: inch, RH side column: inch).

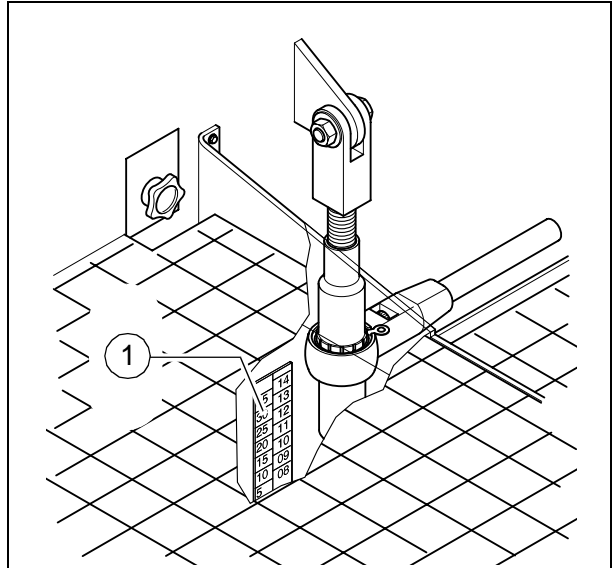

F0116_A1.EPS

2.4 In case of hydraulic adjustment (option)

- Determine the currently set height of the auger crossbeam (left and right) by means of the scale (1).

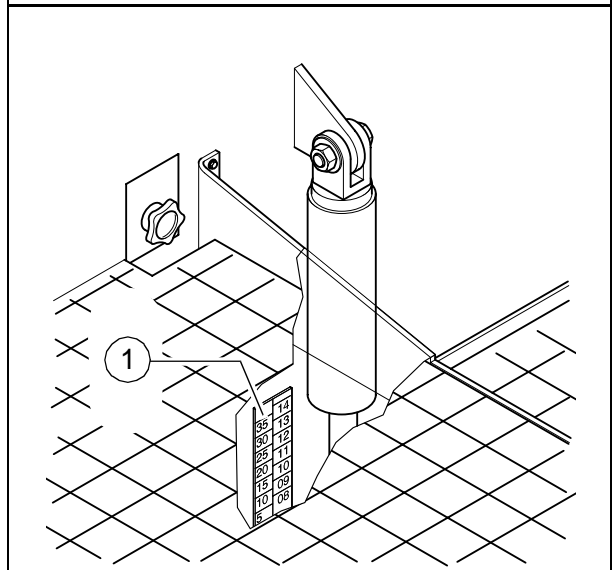

F0117_A1.EPS

m Equally press both switches/buttons (2) so that the auger beam does not get into inclined position.

- Check whether the heights on the left and on the right are identical.

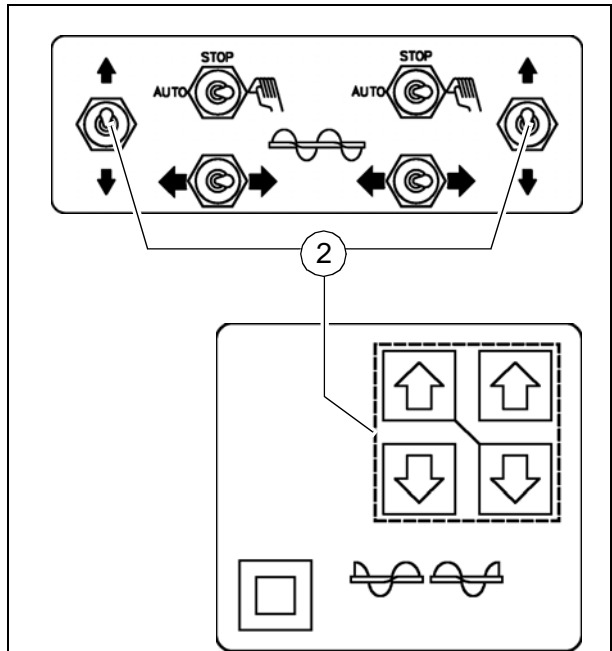

Screedlift_konv.bmp/Screedlift_SPS.bmp

A The height indicating scales (3) may be optionally also along the climbing rungs on the LH/RH sides!

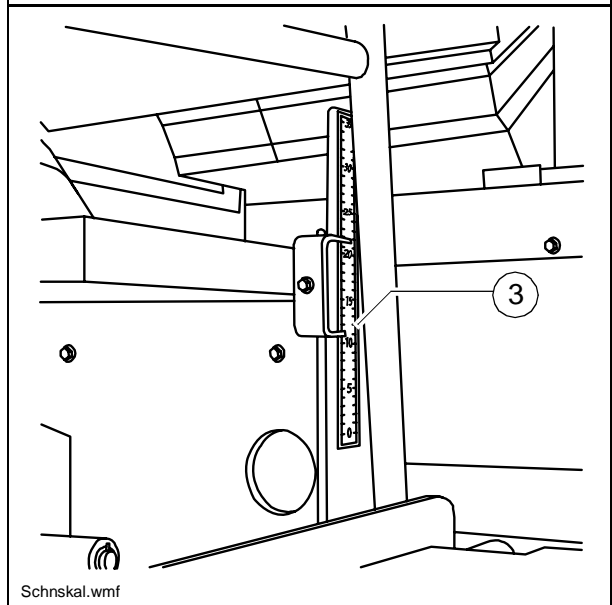

Schnskal.wmf

2.5 Auger extension, auger type I

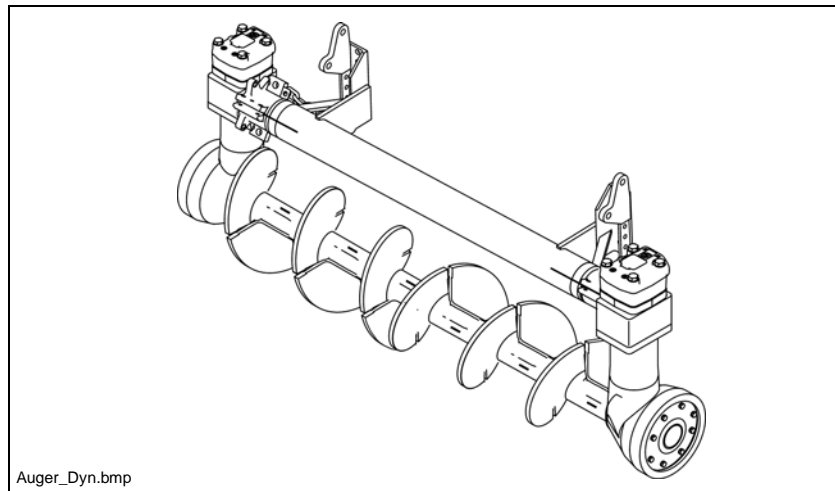

Depending on the type of screed, the most diversified working widths can be reached.

- A** Auger and screed extension must match. See the operating instructions of the appropriate screed, chapter "Set-up and modification", especially:
- Screed extension chart,
 - Auger extension chart.

To attain the desired working width, the respective screed extensions, side plates, augers, tunnel plates or cut-off shoes must be mounted.

For widths of more than 3.00 m, the auger should be fitted with extension parts on both sides to improve material distribution and to reduce the wear.

- f** The diesel engine must be switched off whenever work is performed on the auger. Danger of injuries!

2.6 Mounting extension parts

- Loosen the clamping screws (6) on the support tube. Then turn in the center expanding screw (5) to expand the clamping joint.

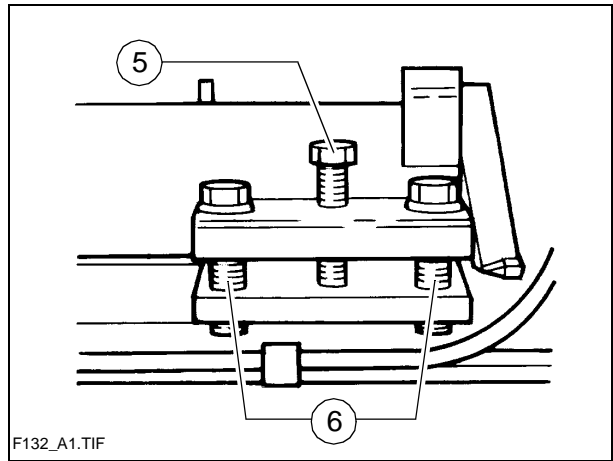

- Pull the telescopic tube out of the support tube (7).
- Mount the required extension parts.

m

Observe the guide groove of the spline! Make sure that the shaft end is clean!

- Slide in the telescopic tube. When doing so, make sure that the drive of the auger gear is slid all the way over the shaft end of the auger extension part and that the threads of the augers match.
- Remove the expansion screw (5). Then tighten the clamping screws (6). Finally tighten the expansion screw by hand.

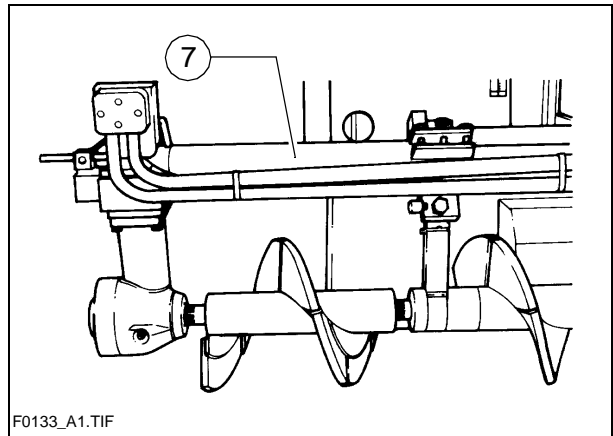

m

Before the clamping screws (6) can be tightened again, the expansion screw (5) must be sufficiently turned back! Otherwise, the telescopic tube cannot be safely clamped and the splined shaft ends break.

f

When clamped insufficiently, the telescopic tube can slide out of the support tube. Danger of accidents during transportation!

2.7 Mounting support tube extensions

If the working width exceeds 7.25 m, an auger crossbeam extension must be mounted.

The support tube extension of the auger crossbeam consists of two halves (8) and is attached to the existing support tube by using a total of 5 screws. After the two halves have been screwed to the support tube, they also must be linked to each other by means of screwed connections.

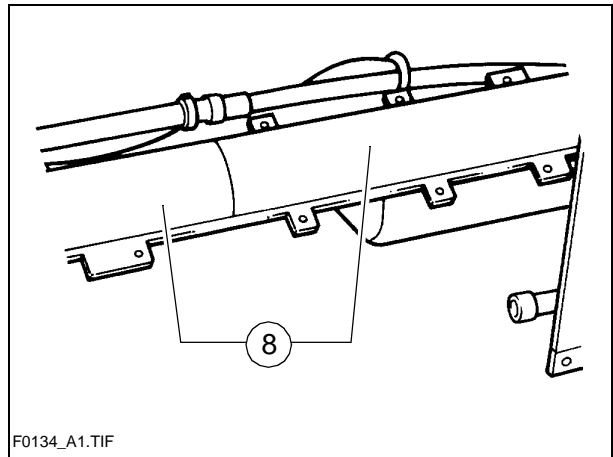

Clamping of the telescopic tube occurs by tightening the screwed connections (9) linking the support tube extension.

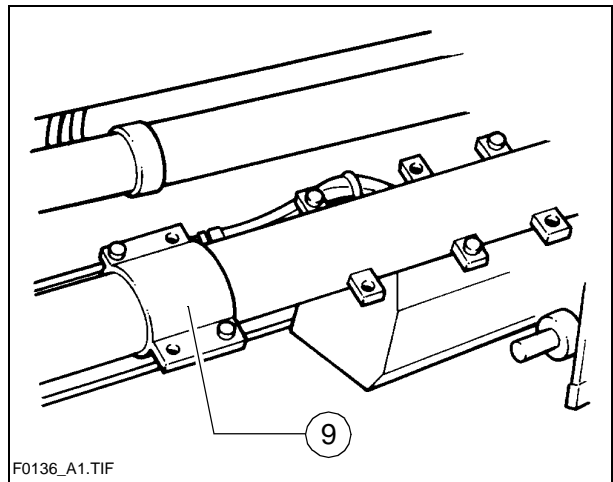

If the working width exceeds 7.50 m the hydraulic hoses (10) for the auger motors must be replaced with longer ones. These long hoses are included in the scope of delivery for this working width.

f When connecting or disconnecting hydraulic hoses, hydraulic fluid can spurt out at a high pressure. Switch off the paver finisher and depressurize the hydraulic circuit! Protect your eyes!

m When installing the hoses, make sure that the area around the connections is clean.

Any dirt that enters the hydraulic system can cause malfunctions.

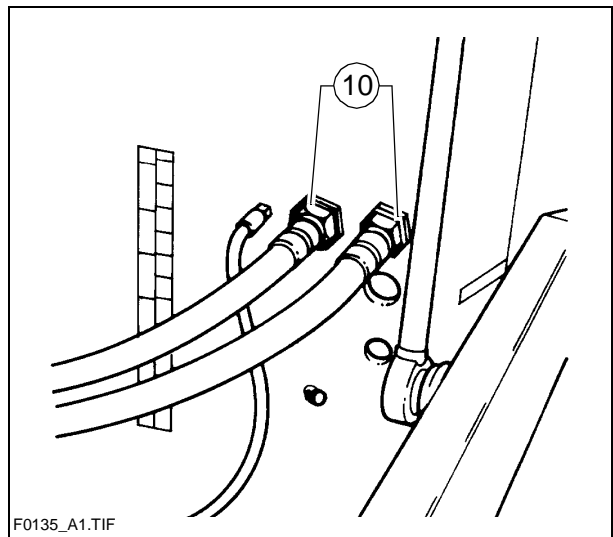

2.8 Installing tunnel plates

To ensure an optimum material flow – especially in the case of large paving widths – so-called tunnel plates (11) must be installed.

They are located directly in front of the auger distributor and – in conjunction with the auger – are an ideal system for conveying the material.

When operating with widths of more than 3.90 m, two or more combined tunnel plates (13) must be used.

In this case, additional stabilizing supports (12) must be attached to the telescopic tube.

The tunnel plates must be directly screwed to the receptacles provided for this purpose (14); they are located on the auger frame sides and can thus be adjusted in height.

Refer to the auger extension chart to determine which parts of the conveyor system are required for the desired paving width.

- A The auger extension chart is contained in the operating instructions for the respective screed.

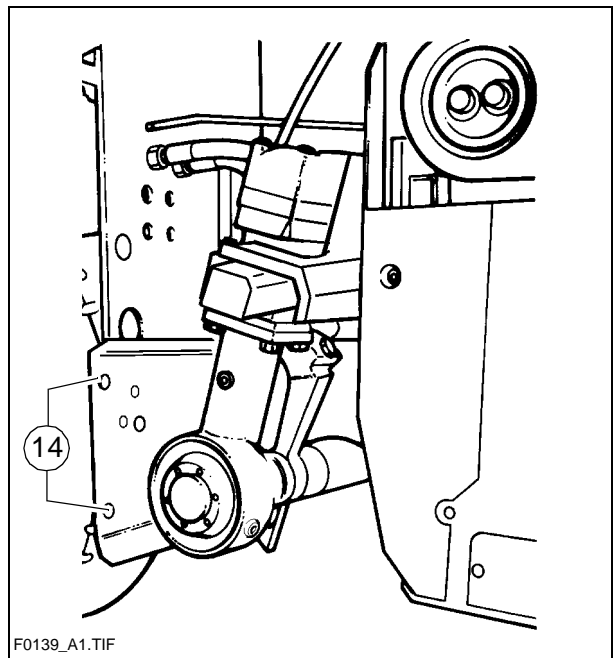
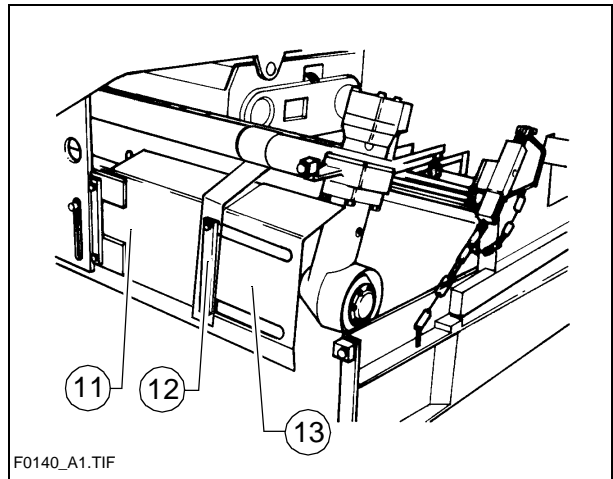

2.9 Installing additional braces

When operating with width of more than 7.25 m the augers must be provided with an additional support.

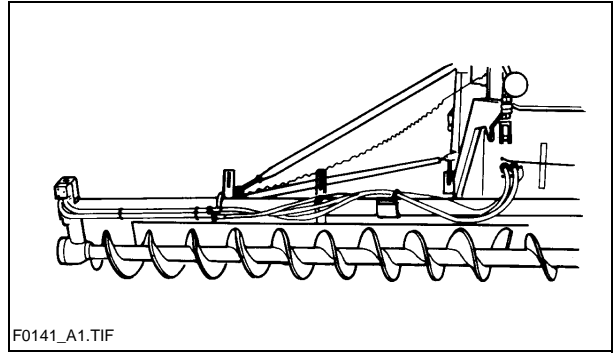

To do so, attach two braces on both the left-hand and the right-hand side, between the tunnel plate support and the bracket provided on the paver finisher.

The braces are included in the scope of delivery for this working width.

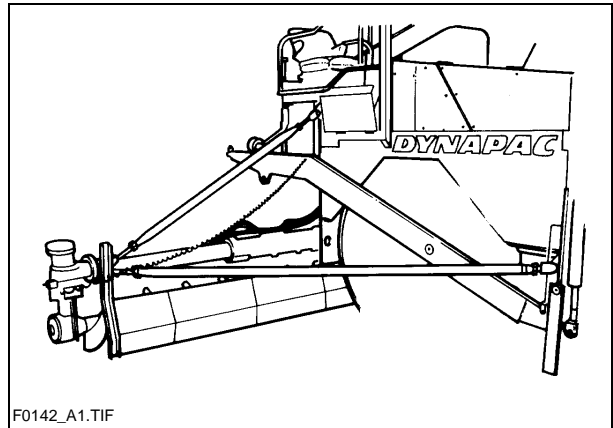

2.10 Auger mounting chart for \varnothing 310 mm auger

Schneckenanbauteile pro Seite										
Schnecke			Führungsblech			Stütze für Führungsblech	Tragrohrverlängerung	Strebe für Schnecke	Hydr. Schlauch lg.	max. Abstand zwischen Begrenzungsblech u. Schnecke
1	2	3	1	2	3					
232	464	928	300	500	700					
										264
1			1							657
	1			1						675
1	1		1	1		1				692
		1	1	1		1				711
1		1	1		1	1				729
	1	1	1	1	1					747
		2	1	1	1	1				533
1		2	1		2	1	1	2	1	551
1		2	1	1	2	1	1	2	1	676
	1	2	1	1	2	2	1	3	1	694

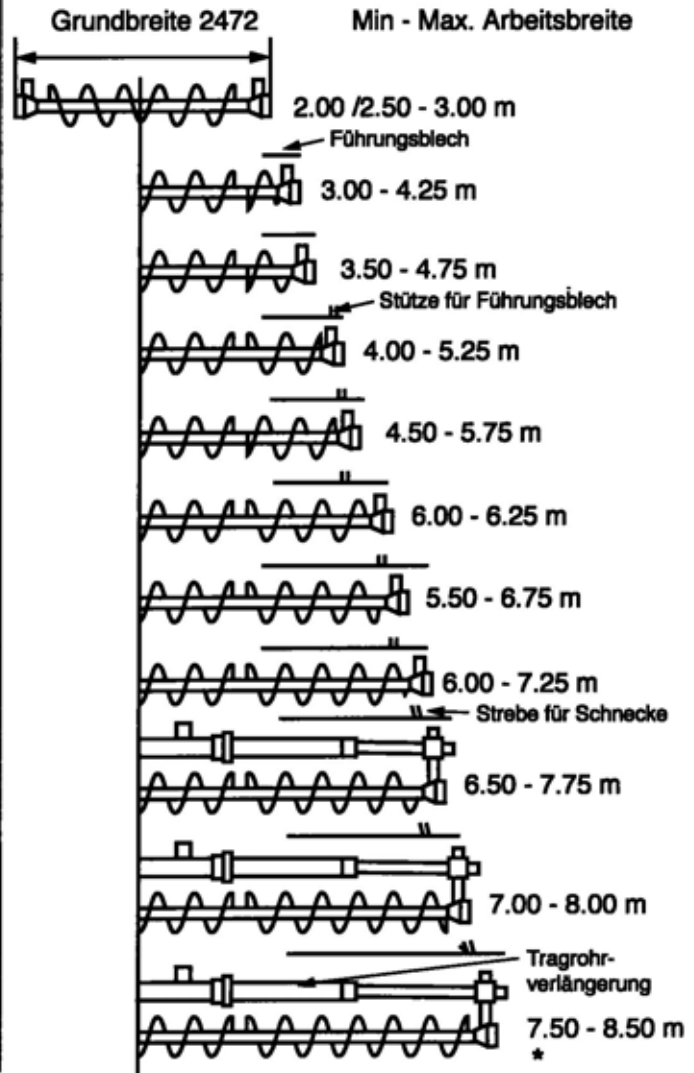

* from working width of 6.75 m the machine can be operated only with appropriate braces (screed, auger, material pipeline).

2.11 Auger mounting chart for ø 380 mm auger

Schneckenanbauteile pro Seite										
Schnecke			Führungsblech			Stütze für Führungsblech	Tragrohrverlängerung	Strebe für Schnecke	Hydr. Schlauch ig.	max. Abstand zwischen Begrenzungsblech u. Schnecke
1	2	3	1	2	3					
290	434	868	300	500	700					264
1			1							599
	1			1						705
1	1		1	1		1				665
		1	1	1		1				771
1		1	1		1	1				731
	1	1	1	1	1					837
		2	1	1	1	1				653
1		2	1		2	1	1	2	1	613
1		2	1	1	2	1	1	2	1	738
	1	2	1	1	2	2	1	3	1	844

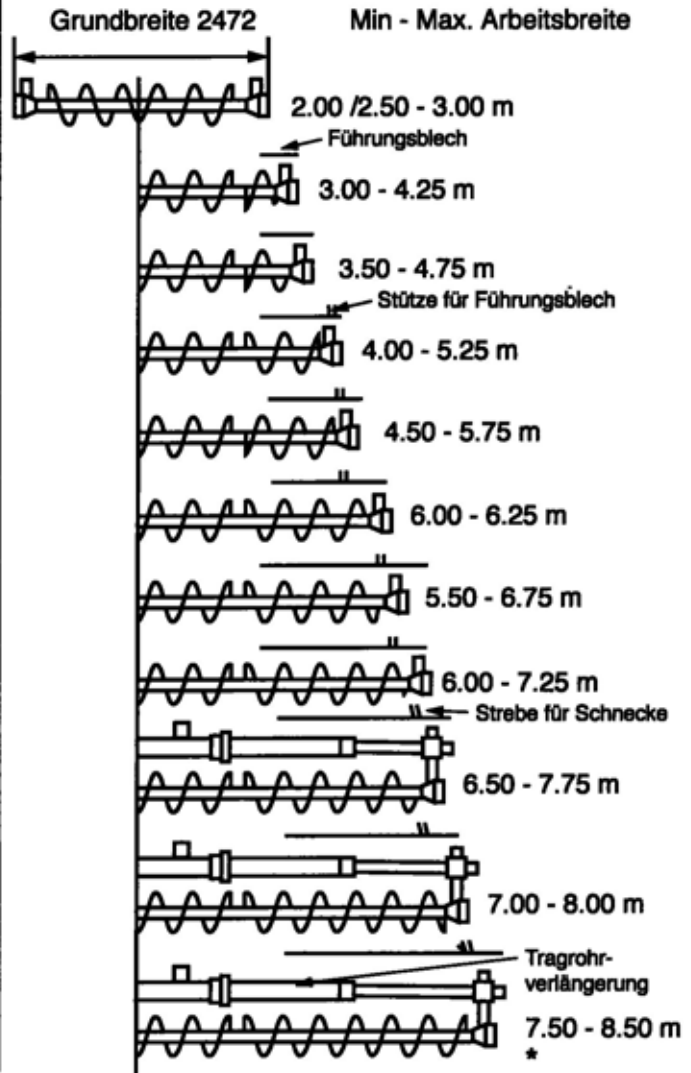

* from working width of 6.75 m the machine can be operated only with appropriate braces (screed, auger, material pipeline).

3 Auger extension, auger type II

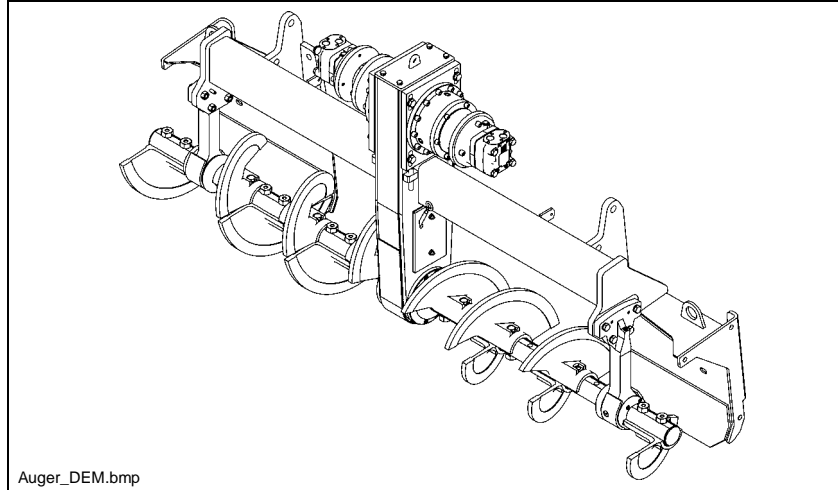

3.1 Mounting extension parts

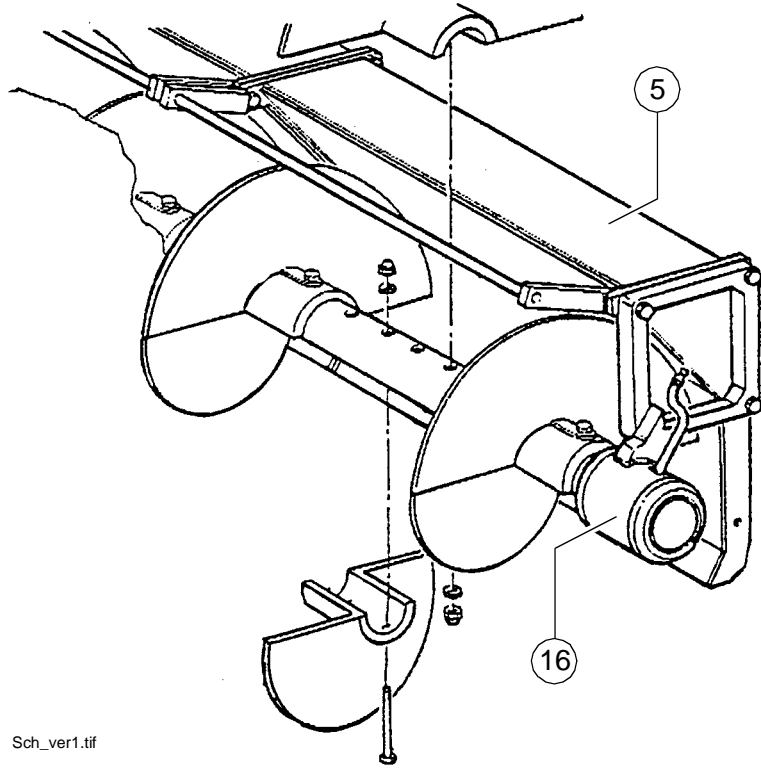

Sch_ver1.tif

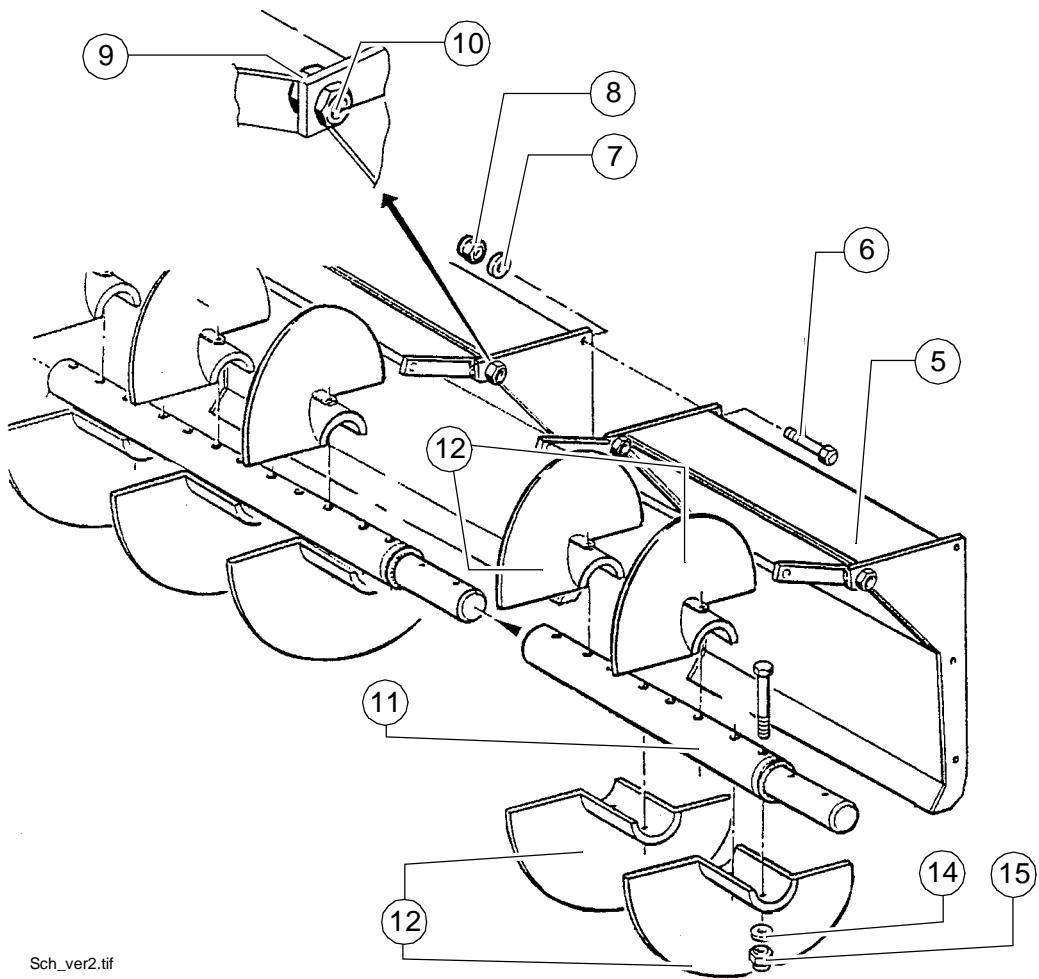





Sch_ver2.tif

- Lock the material shaft (5) with bolts (6), washers (7) and nuts (8) to the basic device.
- The material shaft can be adjusted in order to match the existing shaft.
- Loosen the nuts (9) for this and turn the sleeve (10) of bolt (6).
- Mount the extension of the auger shaft (11) on the auger shaft of the basic device.
- Fasten the auger segments (12) using bolts (13), washers (14) and nuts (15) for the extension of the auger and simultaneously bolt the auger shafts firmly together.

A If the application conditions on the job-site allow or demand auger extension, by all means dismount the external bearing of the auger (16), if the auger extension is longer than 600 mm.

When extending the auger on the basic device with external auger bearing, the shorter auger segment shall be mounted on the bearing. In the opposite case, both the auger segment and the bearing may get damaged, when paving with 30 mm aggregate.

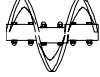
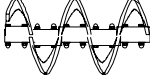
3.2 Auger modification plan.

Marking	Meaning
	Basic auger
	Auger section to be mounted + material shaft 320mm
	Auger section to be mounted + material shaft 640mm
	Auger section to be mounted + material shaft 960mm
	Auger - outer bearing

Paving width	Mountable parts / bearing		Mountable parts / bearing
2.5 m - 3.7 m			
3.2 m - 4.4 m			
4.1 m - 5.0 m			
4.1 m - 5.0 m			
4.8 m - 5.7 m			
4.8 m - 5.7 m			
5.4 m - 6.3 m			
5.4 m - 6.3 m			
6.0 m - 6.9 m			
6.0 m - 6.9 m			
6.7 m - 7.6 m			
6.7 m - 7.6 m			
7.3 m - 8.2 m			
7.3 m - 8.2 m			
8.0 m - 8.9 m			
8.6 m - 9.6 m			

4 Screed

The operating instructions for the screed cover all work required for mounting, setting up and extending the screed.

5 Electrical connections

Establish the following connections when the mechanical components have been mounted and set up:

5.1 Remote controls

to socket (15) (on the screed).

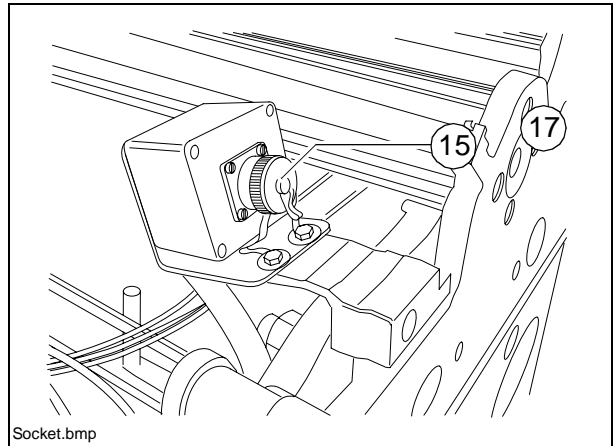

5.2 Grade control

to socket (16) (on the remote control unit)

5.3 Auger limit switches

to socket (17) (on the remote control unit)

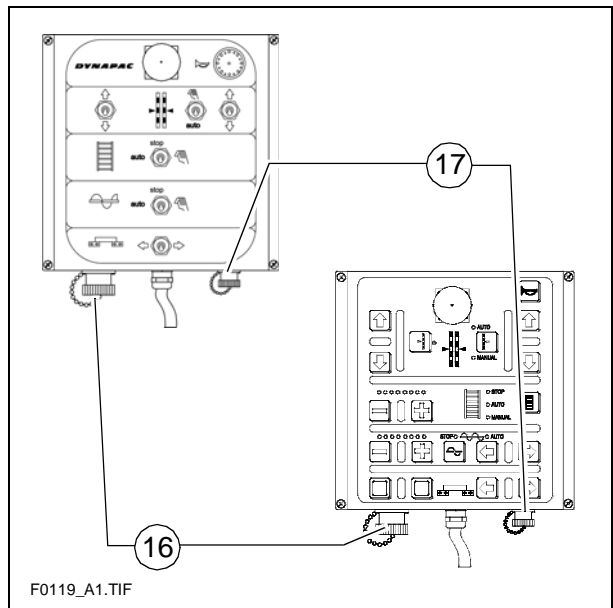

5.4 Working lights

to sockets (18) (on the paver finisher).

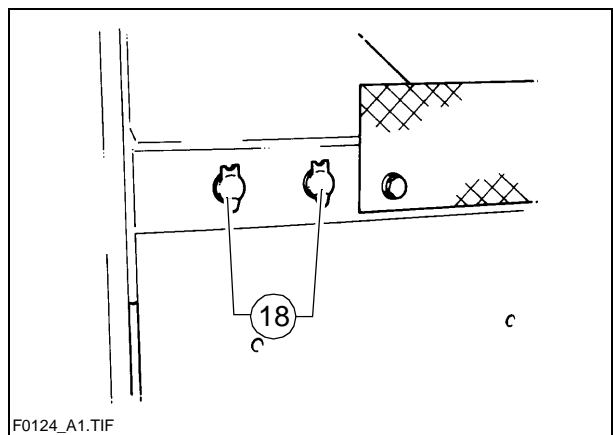

F 1.0 Maintenance

1 Notes regarding safety

f **Maintenance work:** Maintenance work may only be carried out when the engine is at a standstill.

Secure the paver finisher and the attachments against inadvertent starting before beginning any maintenance work:

- Set the drive lever to the center position and the speed preselector to zero.
- Remove the traction drive fuse from the operating panel.
- Remove the ignition key and the battery main switch.

f **Lifting and jacking up:** Secure lifted machine parts (e.g. screed or hopper) against lowering by means of mechanical supports.

m **Spare parts:** Use only approved parts and install them according to the specifications! If in doubt, contact the manufacturer!

f **Re-commissioning:** Mount all protective devices before re-commissioning the paver finisher.

f **Cleaning:** Cleaning must not be carried out while the engine is running. Do not use any inflammable substances (such as petrol). Avoid directly cleaning electrical parts and insulation material with a steam jet; cover them up beforehand.

f **Working in closed environments:** Exhaust fumes must be led into the open. Propane gas bottles must not be stored in closed rooms.

m In addition to these Maintenance Instructions, the Maintenance Instructions of the engine manufacturer must always also be observed. All other maintenance work and intervals noted in these instructions are also binding.

A The instructions for the maintenance of the optional equipment are included in the sub-chapters of this chapter.

F 2.6 Maintenance overview

1 Maintenance review

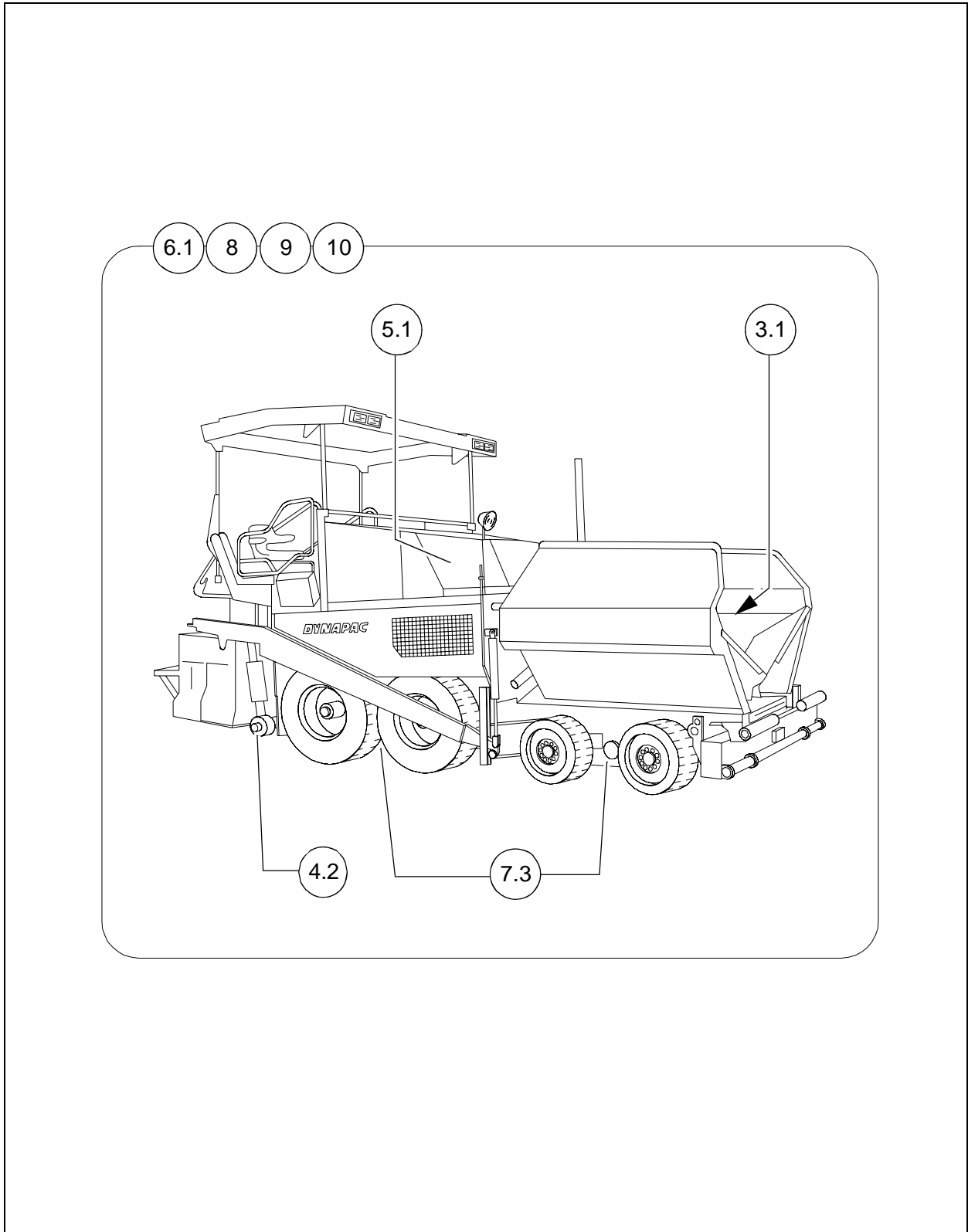

Sub-units	Chapter	Maintenance required after the following service hours.									
		10	50	100	250	500	1000 / year	2000 / 2 years	5000	20000	as required
Feeder	F3.1	q	q				q				q
Auger	F4.2	q	q		q		q	q			q
Drive engine	F5.1	q			g	q	q	q			q
Hydraulics	F6.1	q	q			q	q	q			q
Travel drive, steering	F7.3	q	q				q				q
Electronics	F8			q	q				q	q	q
Lubrication points	F9	q	q					q			q
Checking/stopping	F10	q					q				q

Maintenance required	q
Maintenance during the running-in period	g

A This review also includes the maintenance intervals of the optional equipment of the machine!

F 3.1 Maintenance - Conveyor

1 Maintenance - Conveyor

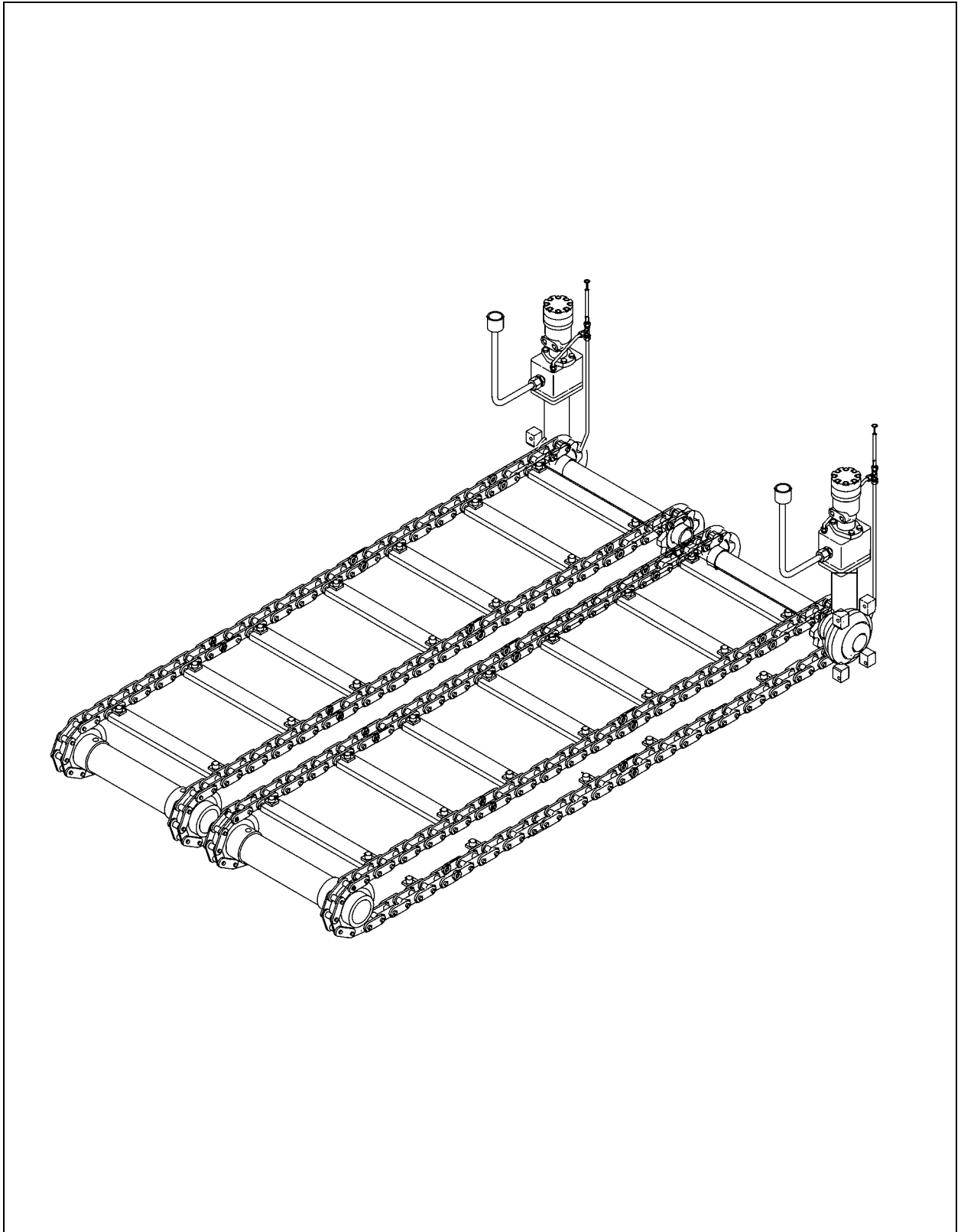

1.1 Maintenance intervals

No.	Interval							Points of maintenance	Remark
	10	50	100	250	500	1000 / year	2000 / 2 years as required		
1	q							- Checking the tightness of the conveyor chain	
							q	- Adjustment of the tightness of the conveyor chain	
2		q						- Checking the oil level of the conveyor drive	
							q	- Topping up the oil level of the conveyor drive:	
						q		- Changing the oil of the conveyor drive	

Maintenance	q
Maintenance during run-in period	g

1.2 Points of maintenance

Chain tightness of the conveyor (1)

Checking the track tightness:

For daily inspection look straight through under the bumper. The chain must not hang below the bottom edge of the bumper.

Should readjustment be necessary, measure the slack unloading from the bottom edge of the floor plate until the lower edge of the chain (see the figure).



m

The chains should not be too tight or too slack. Material between the chains and the sprocket wheel can lead to stoppage or breakage, in case of too tight chains. If the chain is too slack, it may get stuck in the protruding objects and be damaged.

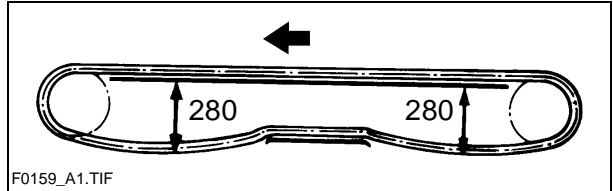

Adjustment of chain tightness:

A

The (A) adjusting screws are located at the front on the cross-beam.

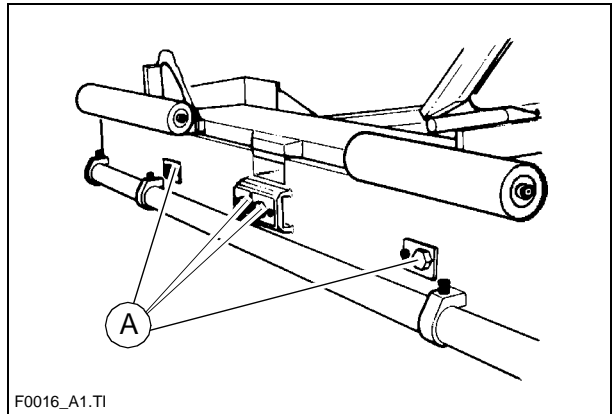

The drive of conveyor (to the left/to the right) (2)

The drive unit of the conveyor is under the floorboard of the operating position.

Checking the oil level Only before the work starts. The oil level must reach the upper notch of the dipstick (A).

Filling in the oil: After removing cover lid (B) through fill-in stub (C).



- A On the dipstick about 10 cm corresponds to about 0,25 l oil to be added. The drive of the conveyor is filled in the factory with Optimol Optigear 220 oil. Owing to the excellent quality of the oil filled in, there is no need for regular oil change. It is sufficient to regularly check the oil level in the drive (see chapter of maintenance intervals).

- m The above applies only if Optimol Optigear 220 or oil of a similar quality from another manufacturer is used.

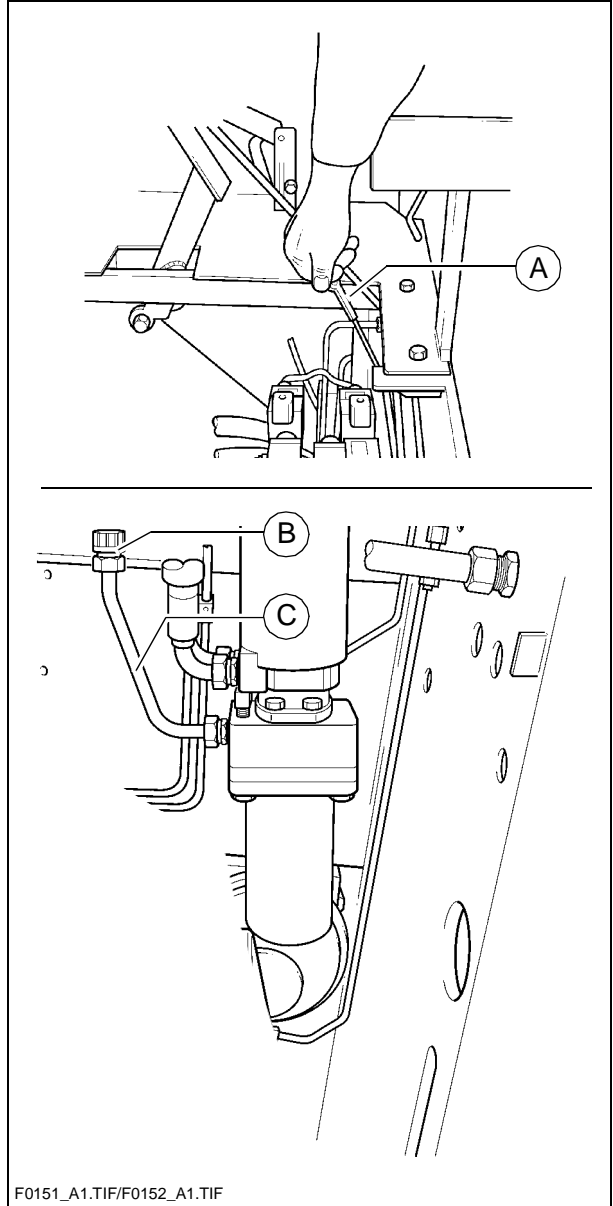

F 4.2 Maintenance - Auger

1 Maintenance - Auger sub-unit I

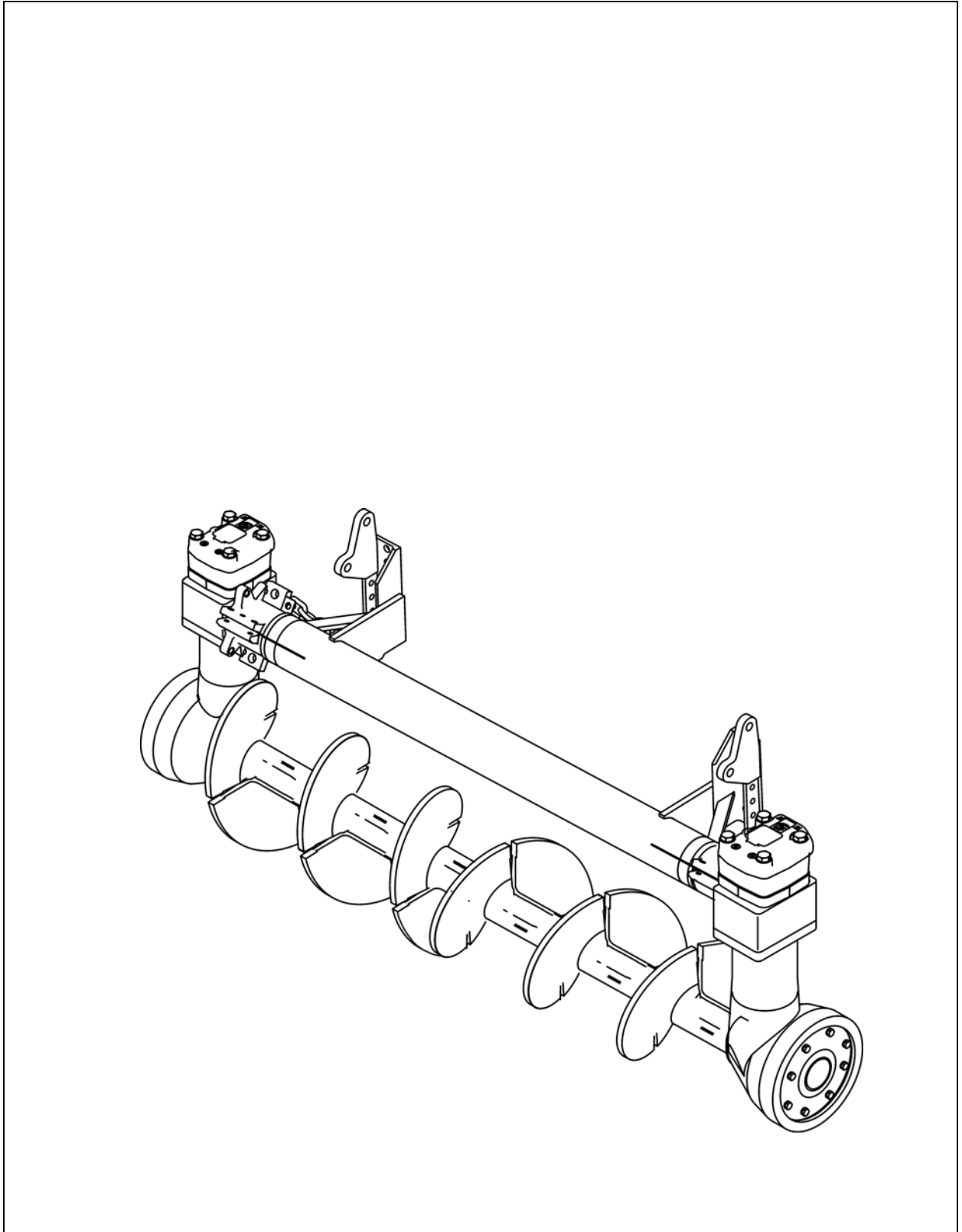

1.1 Maintenance intervals

No.	Interval							Points of maintenance	Remark
	10	50	100	250	500	1000 / year	2000 / 2 years as required		
1	q							- Auger - outer bearing Lubrication	
2			q					- Auger central bearing Lubrication	
3					q			- Auger drive neck bearing Lubrication	
4	q							- Auger bevel gear oil level check	
							q	- Auger bevel gear topping up the oil	
						q		- Auger bevel gear oil change	

Maintenance	q
Maintenance during run-in period	g

1.2 Points of maintenance

Auger - outer bearing (1)

The grease nipples (A) are located on each side on the top of outer bearing. These nipples must be lubricated each time when work is finished.



- A The outer bearings of the auger shall be lubricated when hot, so that the eventual bitumen residues are expelled.

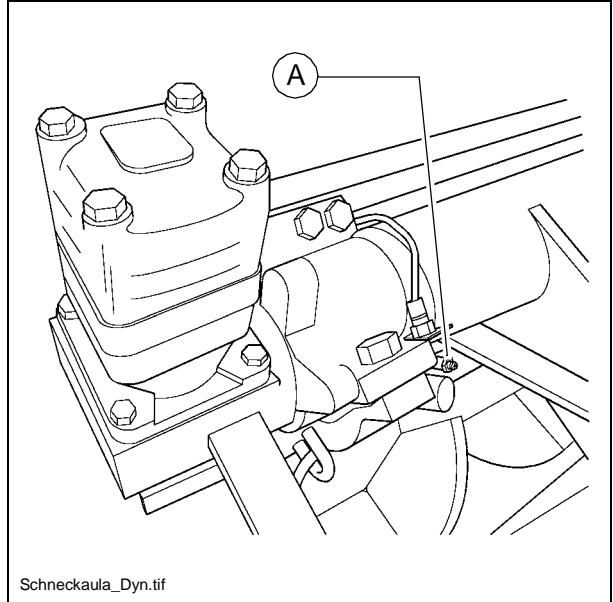

Auger middle bearing (2)

Lubrication of central bearing (A) is performed on the LH-side of the auger. To do so, the bevel gear unit must be pulled off.



- A The central bearing shall be lubricated when hot, so that the eventual bitumen residues are expelled.

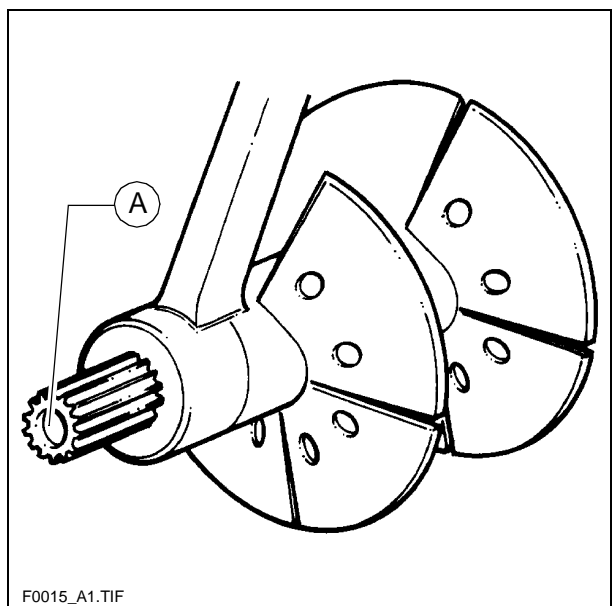

Auger - drive gear neck bearing (3)

Remove the hexagonal screw plug (A) in the neck of the drive. Replace the screw under it with a grease nipple 10x1. Using a grease gun press in about 10 strokes of grease.



- A Thereafter, unscrew the grease nipple and drive in both screws. The neck of the drive is sealed downwards and is lubricated with grease only.

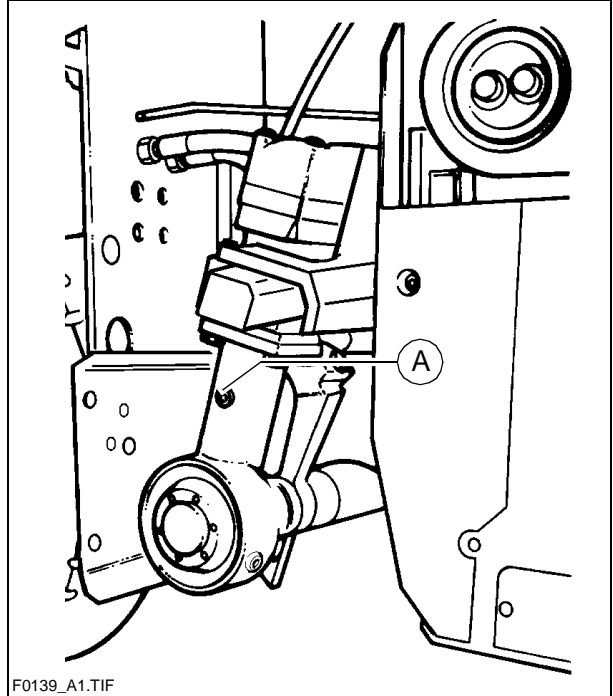

F0139_A1.TIF

Auger bevel gear (on the RH and LH sides) (4)

- For **checking the oil level** unscrew the inspection / filling plug (A).

A

In case of proper oil level, the oil is at the lower edge of the inspection port or a little oil flows from the hole.

For **filling in** the oil:

- Remove the inspection / filling plug (A).
- Fill oil of the correct specification through the filling hole (A) until the oil level reaches the lower edge of the inspection hole (A).
- Replace the inspection / filling plug (A).

For **changing** the oil:

A

Change the oil when the engine is at operating temperature.

- Remove the inspection / filling plug (A) and the drain plug (B).
- Drain the oil.
- Drive in the oil drain plug (C) again.
- Fill oil of the correct specification through the filling hole (A) until the oil level reaches the lower edge of the inspection hole (A).
- Replace the inspection / filling plug (A).

m

Take care of cleanliness!

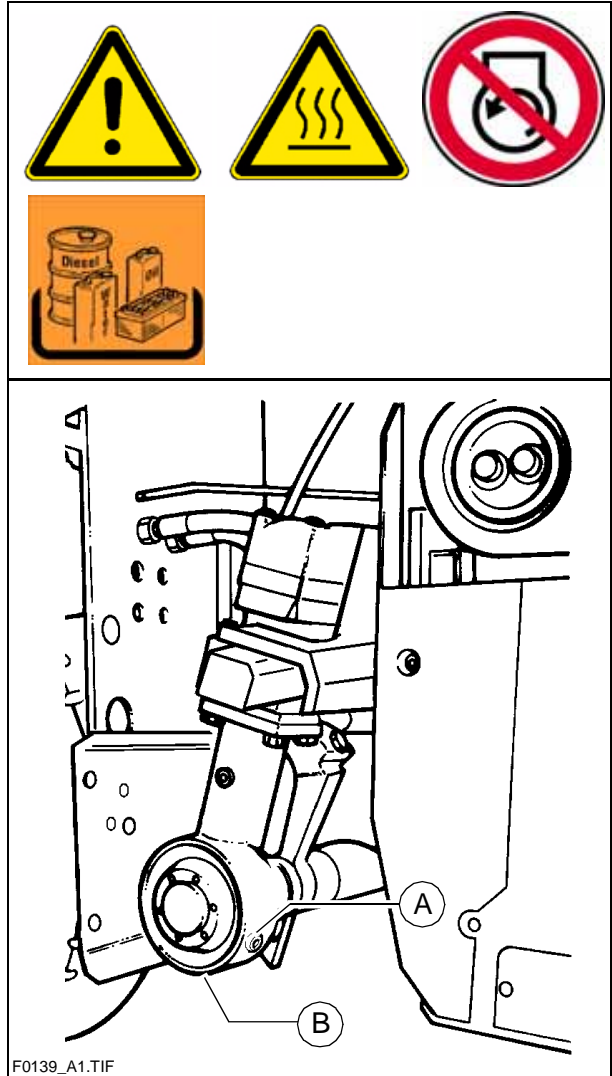

F0139_A1.TIF

F 5.1 Maintenance - Engine

1 Maintenance - engine sub-unit

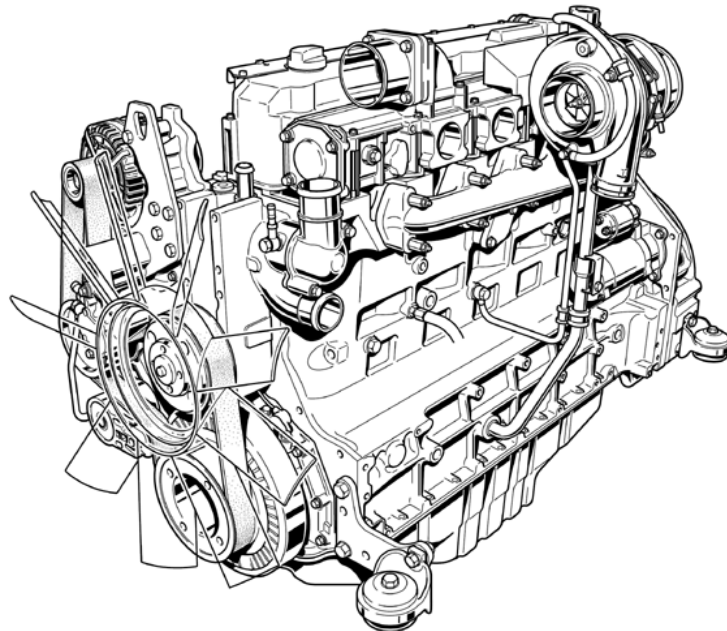
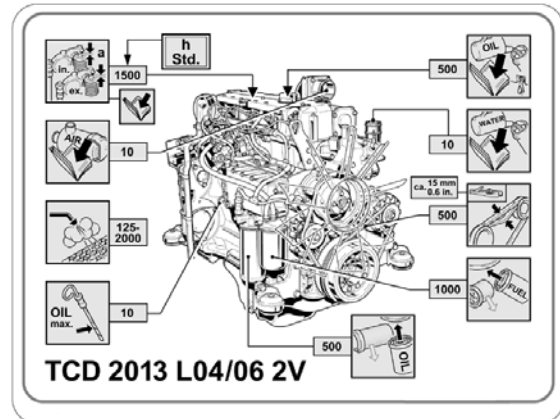

m

In addition to these Maintenance Instructions, the Maintenance Instructions of the engine manufacturer must always also be observed. All other maintenance work and intervals noted in these instructions are also binding.

1.1 Maintenance intervals

No.	Interval							Points of maintenance	Remark
	10	50	100	250	500	1000 / year	2000 / 2 years as required		
1	q							- Fuel tank Check the filling level	
							q	- Fuel tank Refill with fuel	
							q	- Fuel tank Clean the tank and device	
2	q							- Engine lube-oil system oil level check	
							q	- Engine lube-oil system topping up the oil	
					q			- Engine lube-oil system oil change	
					q			- Engine lube-oil system oil filter change	
3	q							- Engine fuel system Fuel filter (drain the water separator)	
						q		- Engine fuel system replacement of the fuel pre-filter	
						q		- Engine fuel system replacement of the fuel filter	
							q	- Engine fuel system bleeding of fuel system	

Maintenance	q
Maintenance during run-in period	g

No.	Interval							Points of maintenance	Remark
	10	50	100	250	500	1000 / year	2000 / 2 years as required		
4	q							- Engine air filter checking of air filter	
	q							- Engine air filter dust collecting bin emptying	
						q	q	- Engine air filter Clean / Replace the filter cartridge	
5	q							- Cooling system of the engine Inspection of radiator fins	
							q	- Cooling system of the engine Cleaning of the radiator fins	
	q							- Cooling system of the engine Check the level of the coolant.	
							q	- Cooling system of the engine topping up the coolant	
							q	- Cooling system of the engine changing the coolant	
					q			- Cooling system of the engine Inspection of coolant (additive concentration)	
6					q	q		- Engine drive belt checking of drive belt	
							q	- Engine drive belt tightening of drive belt	
7	q							- Engine exhaust system checking of particle filter	(o)
				g	q	q		- Engine exhaust system cleaning of particle filter	(o)

Maintenance	q
Maintenance during run-in period	g

1.2 Points of maintenance

Engine fuel tank (1)

- Check the **filling level** on the gauge on the operating panel.

- A
- Fill the fuel tank before each start of work so that the fuel system cannot „run dry“ and this way the time consuming venting (bleeding) can be avoided.

For filling in the fuel:

- Unscrew cap (A) (under the tank cover).
- Fill in fuel through the filling port until the required filling is achieved.
- Replace the cap (A).

Cleaning of tank and device:

- Unscrew the plug (B) at the bottom of the tank and drain into a collection pan about 1 lit fuel.
- After drainage screw back the plug with a new seal ring.

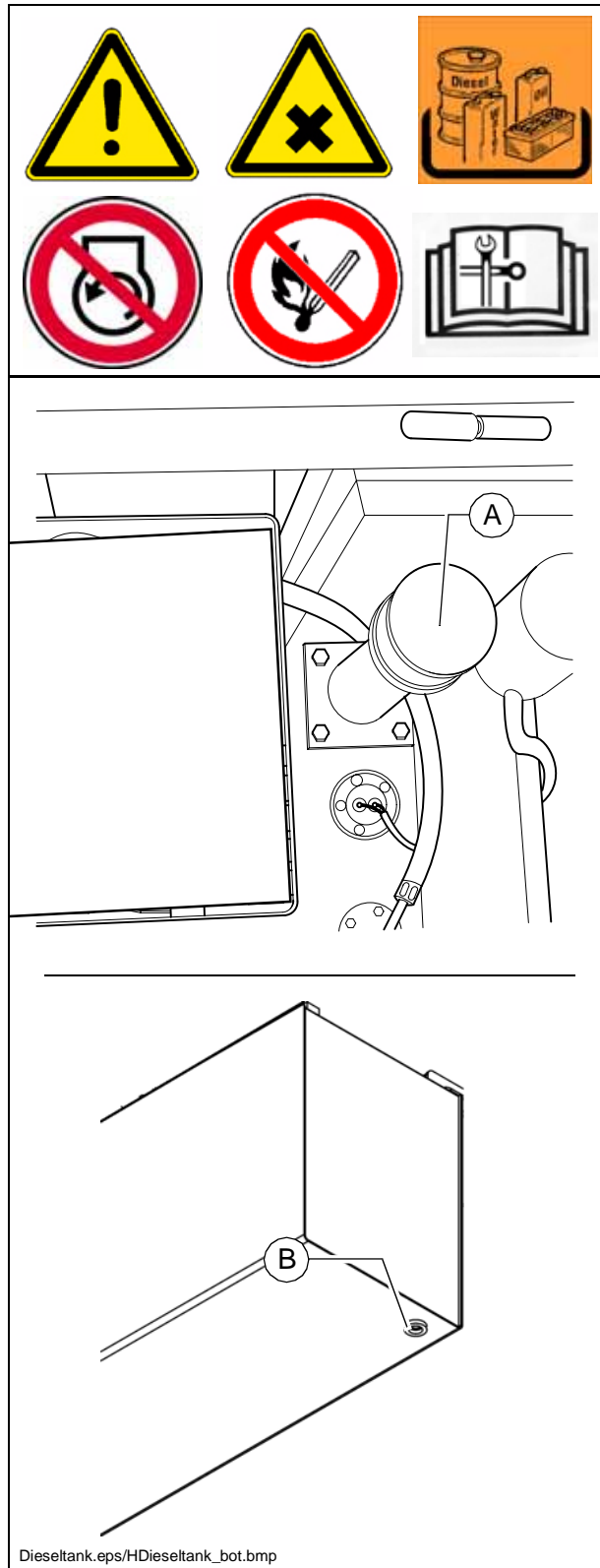

Engine lube-oil system (2)

Checking the oil level

A In case of correct oil level, the oil is between the two notches of the dipstick (A).

A Check the oil level with a paver finisher standing on a flat area!

m If there is too much oil in the engine, the gaskets and seals may get damaged, while too little oil can lead to the overheating of the oil and the damage of the engine.

For filling in the oil:

- Remove cap (B).
- Fill in oil until the correct level is achieved.
- Return cap (B).
- Check the oil level once again using the dipstick.

Oil change:

A Change the oil when the engine is at operating temperature.

- Remove the cover cap of the oil drain port (C) and screw on the hose provided as an accessory.
- Place the end of the hose in a dish to catch the oil.
- Open the shutoff valve with a spanner and let the oil fully drain.
- Shut off the valve, remove the hose and return the cover cap.
- Fill in the oil of specified quality through the filling port on the engine until the oil level rises to the correct mark of the dipstick (A).

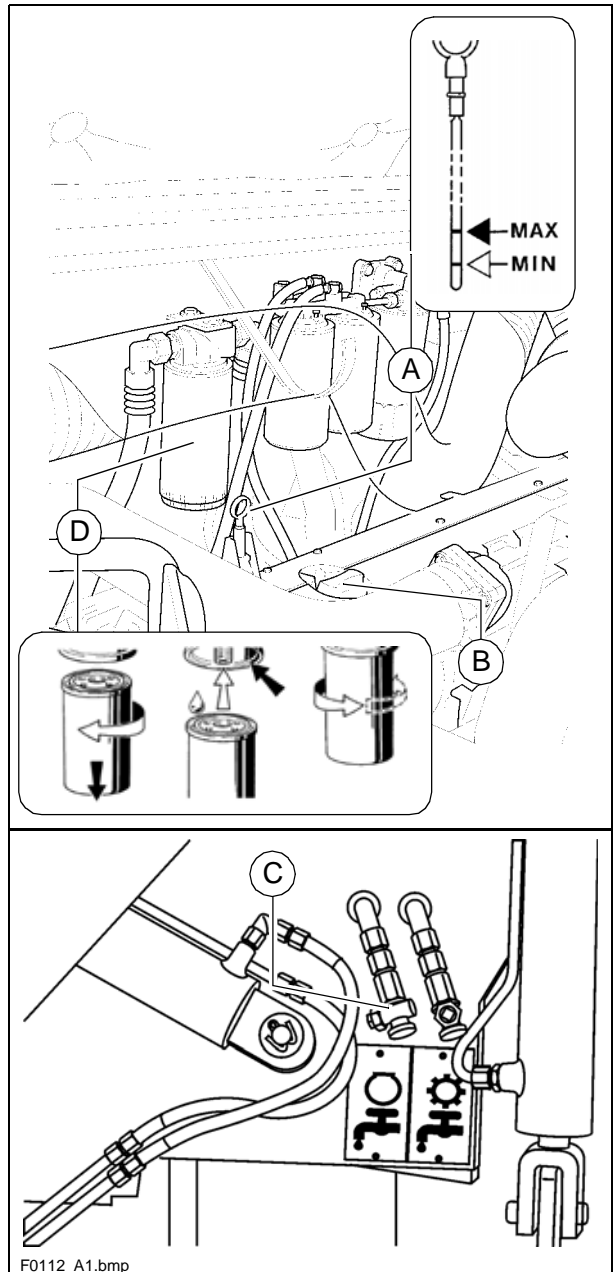
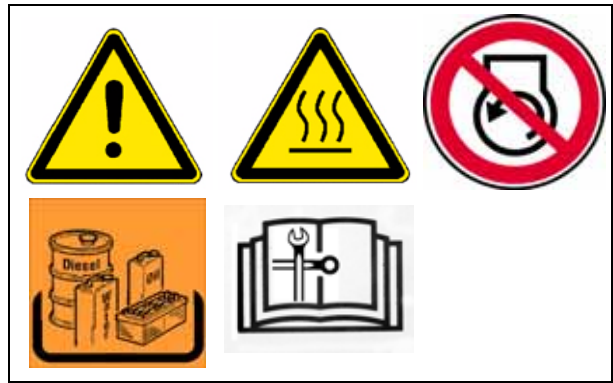

Changing the oil filter:

- A As part of the oil change mount the new filter after the used oil was drained.
- Untighten the filter (D) and clean its resting surface.
 - Apply thin coat of oil to the seal of the new filter and fill the filter with oil before mounting.
 - Tighten the filter by hand.
- A After mounting the oil filter check the oil pressure gauge and the proper tightness during the trial operation. Check the oil level once again.

Engine fuel system (3)

A The fuel filter system consists of three filters:

- Pre-filter (A) with water separator
- Two main filters (B)

A Depending on the machine, the pre-filter is in the engine compartment or under the tank lid!

Pre-filter - draining of water

A Empty the collection bin by the specified intervals or when the engine electronic indicates a fault.

- Drain the separated water at the tap (C), collect it, and close the tap again.



Change of pre-filter:

- Drain the separated water at the tap (C), collect it, and close the tap again.
- Pull down the connection of the water detector (D)
- Untighten the filter cartridge (A) with the collection sump using a pair of oil filter tongs or oil filter strap and unscrew it.
- Unscrew the collection sump (E) from the filter cartridge and clean as required.
- Clean the sealing surface of the filter holder.
- Apply a thin coat of oil to the gasket of the collection sump, drive it under the filter cartridge and tighten by hand.
- Apply a thin coat of oil to the gasket of the filter cartridges, drive them under the holder and tighten by hand.
- Replace the connection of the water detector (D)

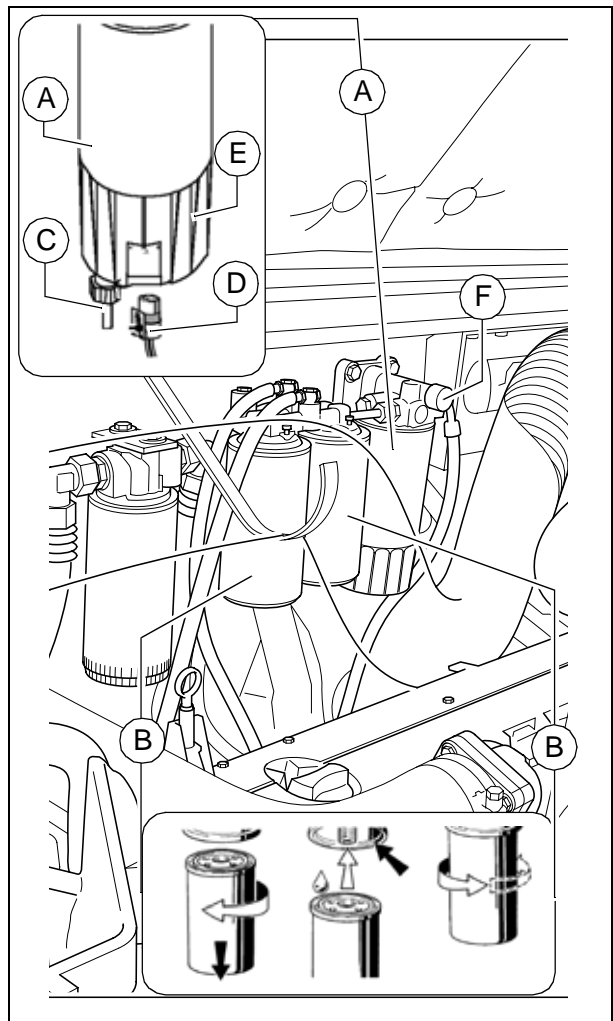

Replacement of the main filter:

- Untighten the filter (B) and clean its resting surface.
- Apply a thin coat of oil to the gasket of the new filter.
- Tighten the filter by hand.

A After mounting the filter check for proper tightness during the trial run.

Venting the filter:

- Release the bayonet-mount of the manual fuel pump (F) by pressing and twisting counter-clockwise at the same time.
- The pump piston now can be displaced by a spring.
- Until strong resistance is felt and the pump moves already very slowly.
- Keep on pumping a few times. (Fill the return pipelines).
- Start the engine and run it for about 5 minutes at idling speed or under a slight load.
- Check the tightness of the pre-filter in the meantime.
- Close the bayonet-mount of the manual fuel pump (F) by pressing and twisting clockwise at the same time.

Engine air filter (4)

Emptying the dust collection bin

- Empty the dust collection valve (B) on the air cleaner housing (A) by pressing the discharge port in the direction of the arrow.
- Discharge the eventually compacted dust by pressing together the upper part of the valve.

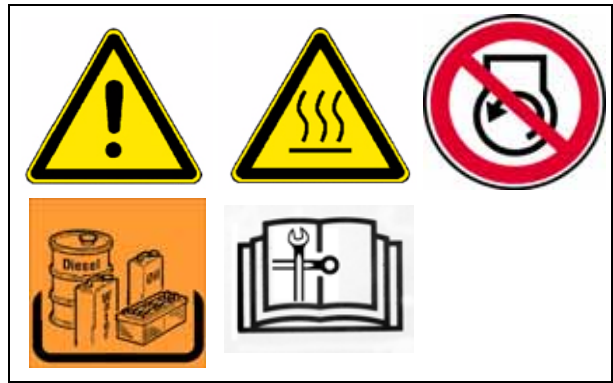

- A Clean the discharge port from time to time.

Cleaning / replacement of the air filter cartridge

- A Pollution of the filter of the combustion air depends on the dust content of the air and the mesh size of the filter selected.

- A The maintenance of the filter becomes necessary if:

- The maintenance indicator (O) red servicing field (C) is fully visible when the engine is stopped.
- When the engine electronic unit indicates service need

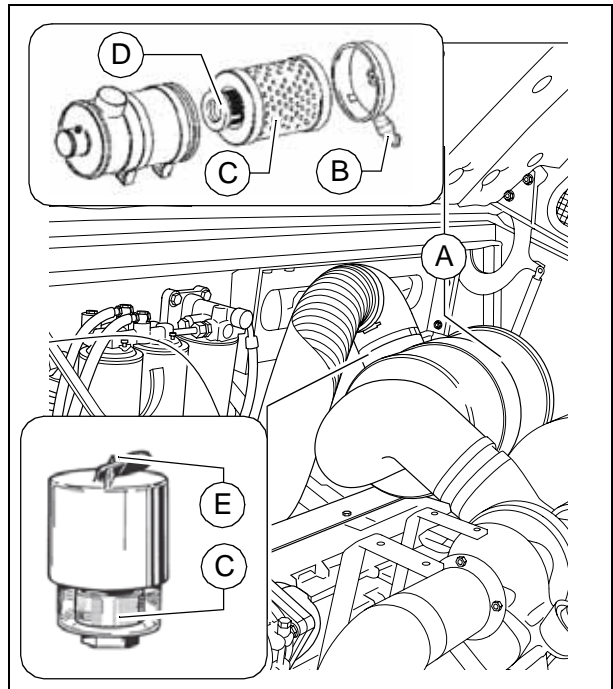

- Open the air filter lid.
- Withdraw the filter cartridge (C) and the safety cartridge (D)

- A Clean the filter cartridge (C) and replace min. after one year.

- Blow out with dry pressure air (max. 5 bar) from inside out or tap it (in case of emergency only).

- A The cartridges should not get damaged in the process.

- Check the soundness of the filter papers of the filter cartridge (by exposing to light) and the soundness of the seals. Replace them as required.

- A Replace the safety cartridge (D) after 5 filter maintenance, but min. after 2 years (never clean it!).

After completing the maintenance works:

- Press the reset button (E) of the maintenance indicator (O). The maintenance indicator is ready for operation once again.

Coolant system of the engine (5)

Checking / topping up of coolant

The coolant level is checked when the engine is cold. Make sure that the anti-freeze and anti-corrosive liquid is sufficient (-25 °C).



f When hot, the system is under pressure. When opening, there is a danger of scalding!

- If necessary fill in sufficient amount of coolant through the open port (A) of the compensating tank.

Changing the coolant

A See operating instructions for the engine

Checking and cleaning of the radiator fins

- If necessary, remove leaves, dust or sand from the radiator.

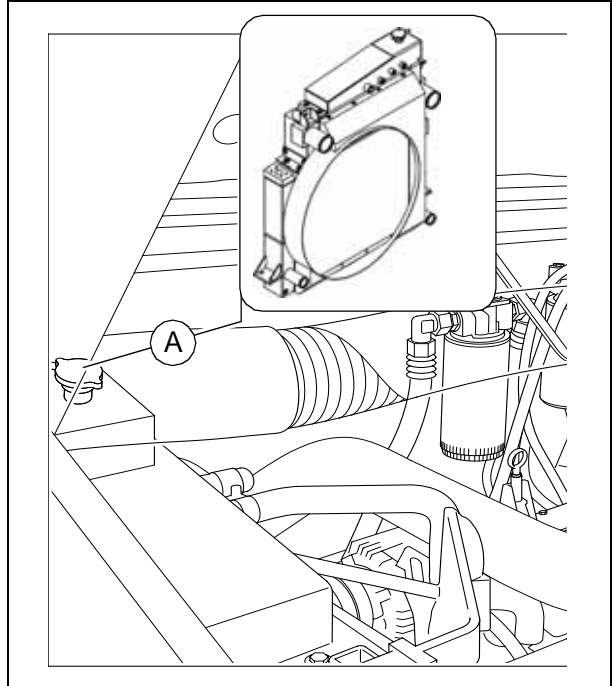

Engine drive belt (6)

Checking of drive belt/replacement

A See operating instructions for the engine

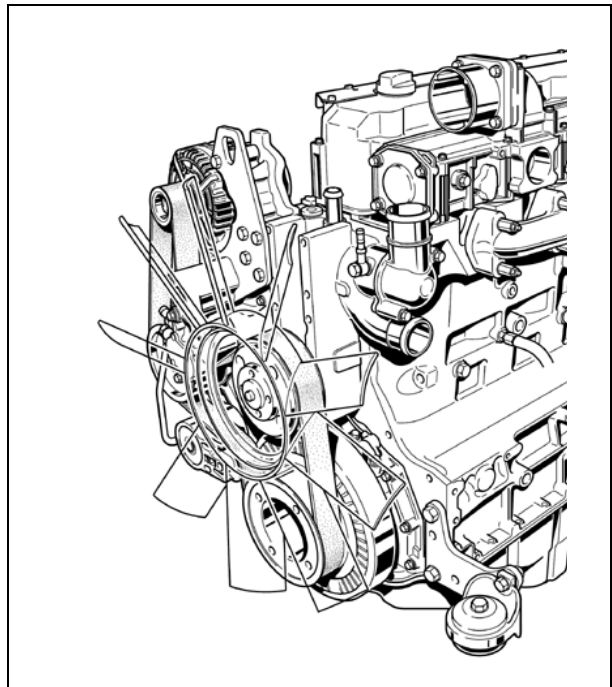

Engine exhaust system (7)

Cleaning of particle filter

m As considerable amount of soot is accumulated in the filter, the cleaning must be performed under appropriate exhaust system.

m Clean the filter element removed with oil-free and grease-free pressure air!

- Marking the flow of direction of the exhaust gas on the filter case.
- Remove the filter element by untightening the two clips (a).
- First blow out the inlet side.

m The pressure of the compressed air can be max. 5 bars and the nozzle shall not be closer to the filter edge than 10 cm.

- Carefully blow out all the filter passages.
- Turn around the filter element, and repeat the process on the other side as well.
- Repeat the process until no more carbon residue leaves the filter.
- Replace the filter element, taking care of the proper direction of flow.

A After cleaning for a short while more soot discharge is expected during operation.

- In case of sticky, oily soot the filter must be heated to about 450°C and the cleaning shall be carried out preferably with the hot filter.

m The filter shall not be cleaned with water/steam or detergent in any case!

f The carbon particles are harmful to your health! In case of filter change or cleaning, wear appropriate protection gear!

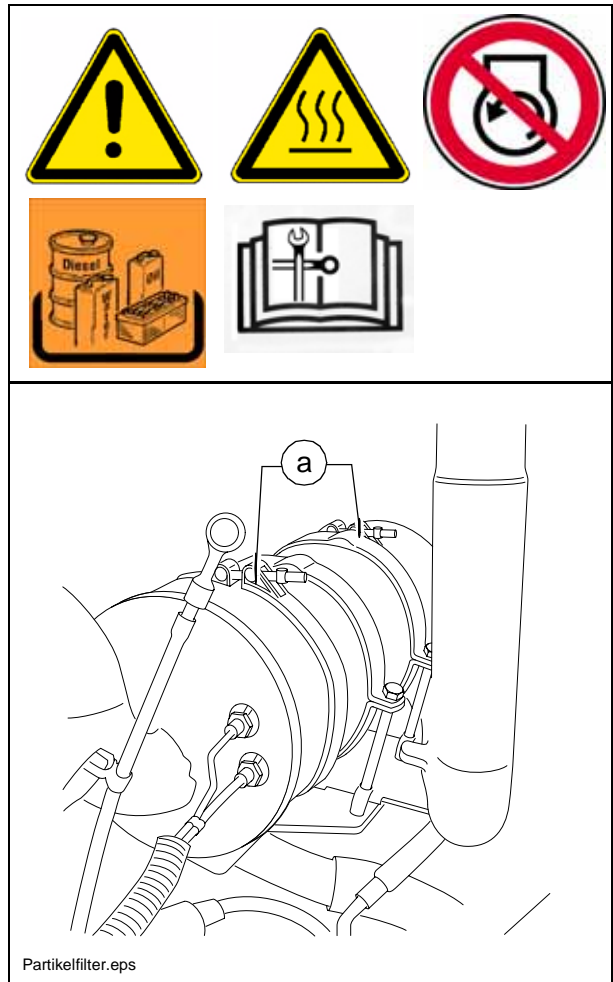

F 6.1 Maintenance - hydraulic system

1 Maintenance - hydraulic system

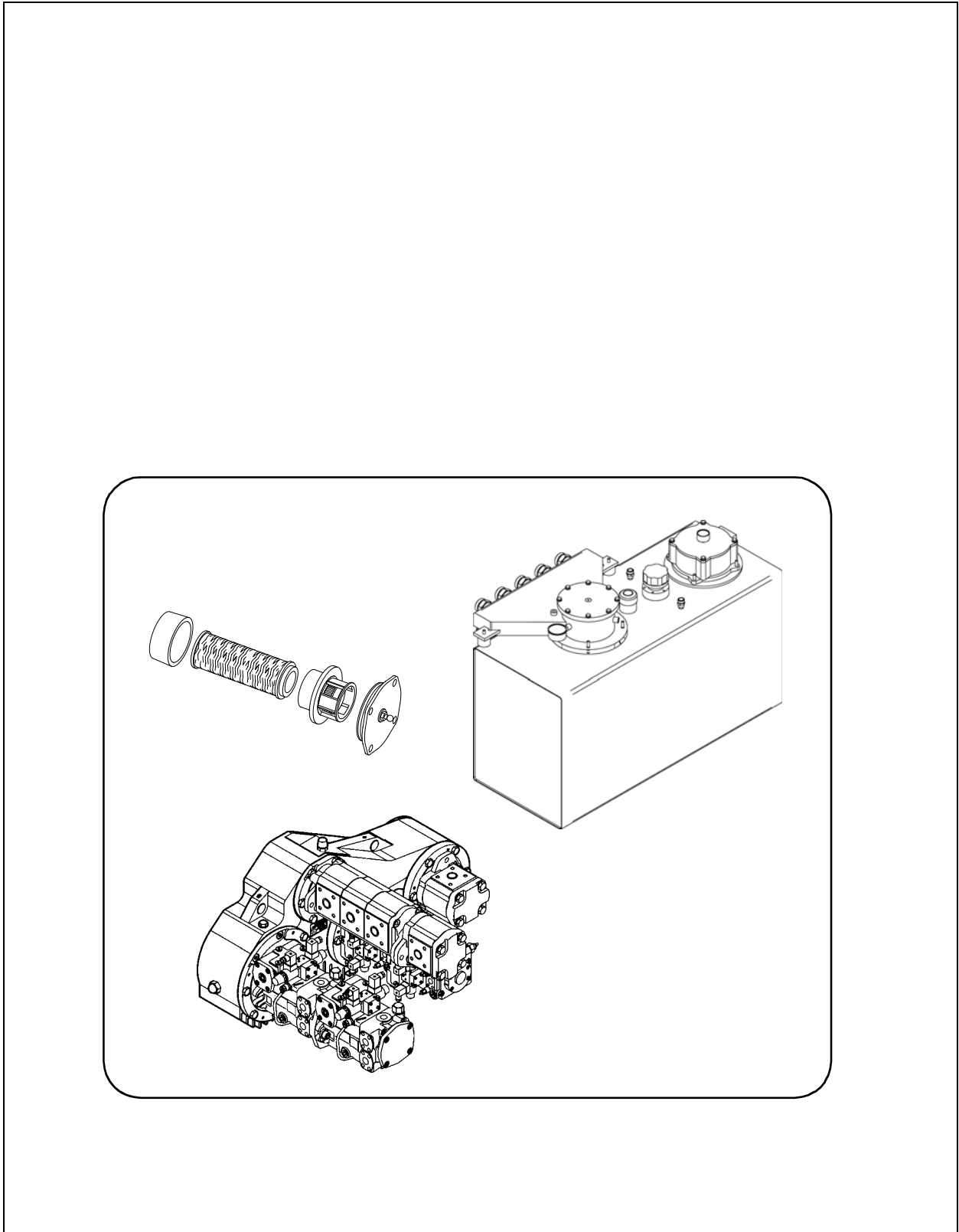

1.1 Maintenance intervals

No.	Interval							Points of maintenance	Remark
	10	50	100	250	500	1000 / year	2000 / 2 years as required		
1	q							- Hydraulic oil tank Check the filling level	
							q	- Hydraulic oil tank Top up with oil	
							q	- Hydraulic oil tank oil change and cleaning	
2	q							- Hydraulic oil tank Checking of maintenance indicator	
							q q	- Hydraulic oil tank Intake / return change of hydraulic filter, venting	
3	q							- High pressure filter Checking of maintenance indicator	
							q	- High pressure filter replacement of filter cartridge	
4		q						- Pump distribution gear oil level check	
							q	- Pump distribution gear topping up the oil	
						q		- Pump distribution gear oil change	
5					q			- Hydraulic hoses observation	
							q q	- Hydraulic hoses Replace the hoses	

Maintenance	q
Maintenance during run-in period	g

1.2 Points of maintenance

Hydraulic oil tank (1)

- **Oil level** check on dipstick (A).

A In case of retracted cylinders the oil level shall be at the upper mark.

For **filling in** the oil:

- Remove cap (B).
- Fill in oil through the filling port until the required filling level is achieved on the dipstick (A).
- Return cap (B).

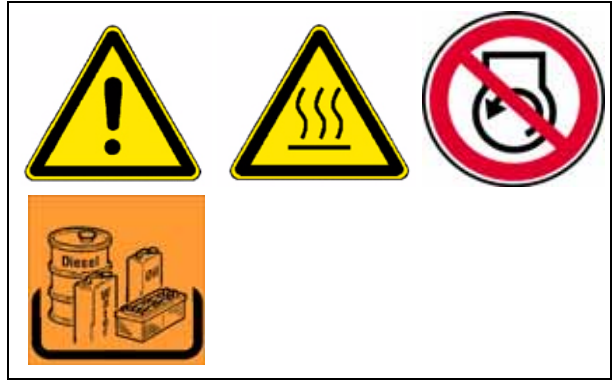

A Regularly clean the vent port of the oil tank from dust and pollution. Clean the surfaces of the oil cooler.

m Use only the recommended hydraulic oils - see section „Recommended hydraulic oils“.

For **changing** the oil:

- To drain the hydraulic oil unscrew the drain plug (C) at the bottom of the tank.
- Collect the oil in a bin using a funnel.
- After drainage screw back the plug with a new seal ring.

A Change the oil when the engine is at operating temperature.

m When changing the hydraulic oil also change the filter.

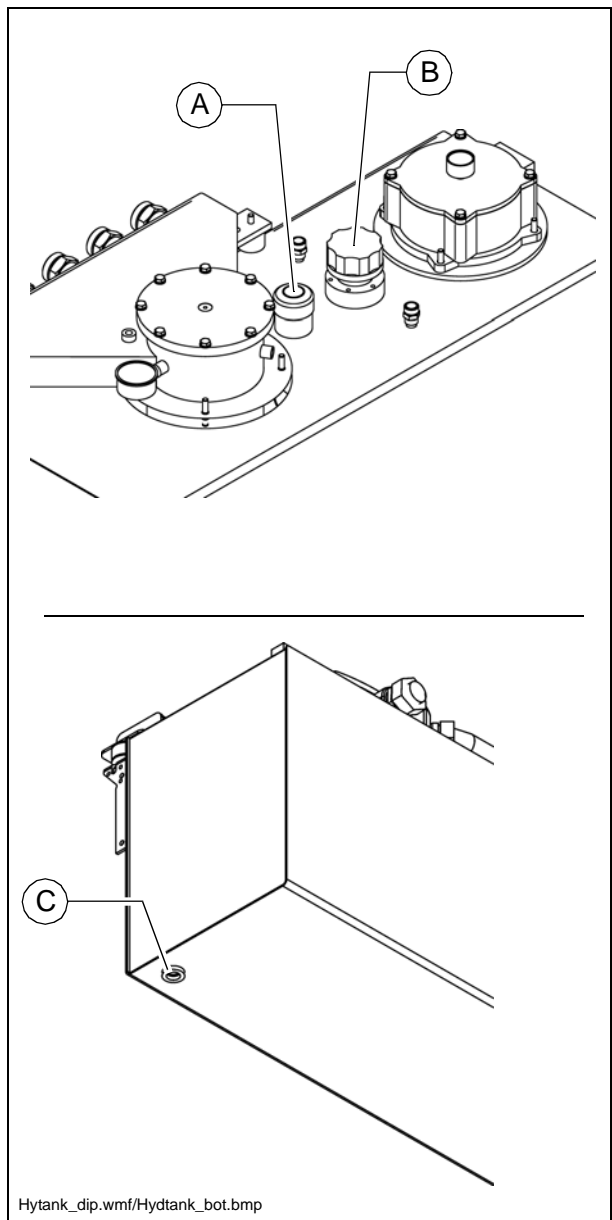

Suction/return flow hydraulic filter (2)

Replace the filter cartridges if the (A) and (B) maintenance indicators reach the red mark.

When changing the hydraulic oil, the filters also need to be changed.

- Unscrew the lid of the filter housing on the hydraulic tank and replace the filter cartridge.

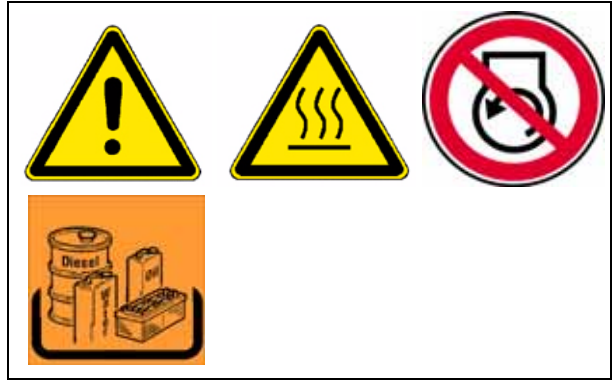

A Do not clean and never use the filter again! Always fit a new filter.

m When changing the hydraulic oil also change the filter.

m Check the seal after changing the filter!

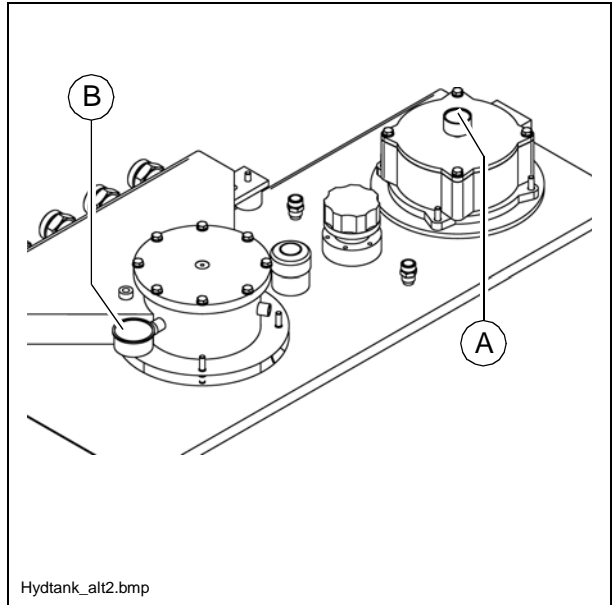

High pressure filter (3)

Replace the filter cartridge when the maintenance indicator (A) turns red.

- Unscrew filter house (B).
- Remove the filter cartridge
- Clean the filter house.
- Insert the new filter cartridge.
- Replace the seal ring of the filter housing.
- Turn on the filter housing by hand and tighten it using a wrench.
- Start the trial operation and check the tightness of the filter.

A Replace the seal ring whenever the filter cartridge is replaced.

A After the replacement of the filter cartridge the red signal of the maintenance indicator (A) automatically reverts to green.

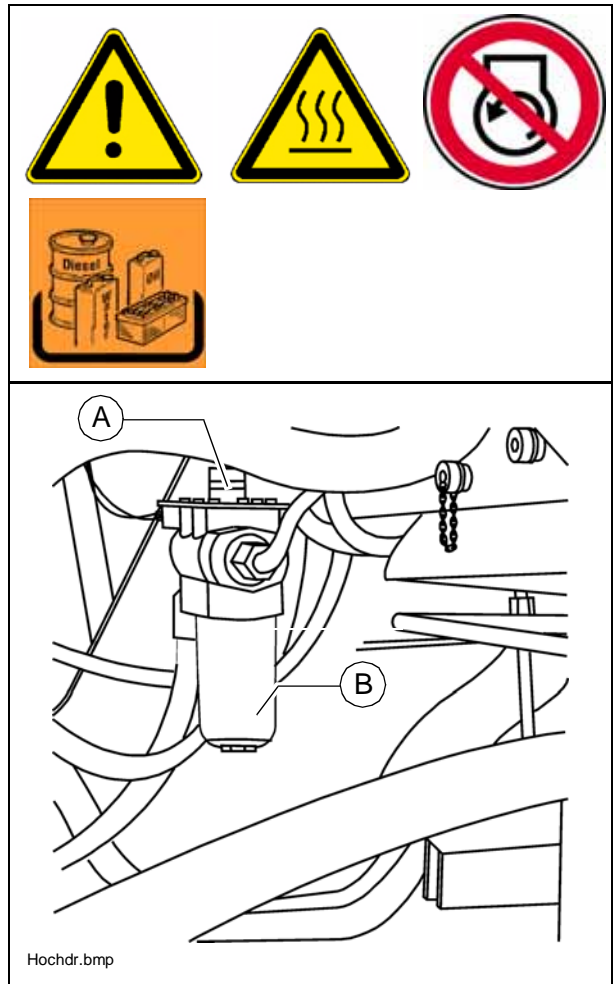

Pump distribution gear (4)

- **Oil level checking** on the viewing glass (A) (at the side of the distribution box).

A The oil level must be up to the center of the viewing glass.

For filling in the oil:

- Unscrew the filling in screw plug (B).
- Fill in oil through the filling port until the required filling level is achieved on the viewing glass (A).
- Return filling screw plug (B).

m Take care of cleanliness!

Oil change:

Change the oil when the engine is at operating temperature.

- Remove the cover cap of the oil drain port (C) and screw on the hose provided as an accessory.
- Place the end of the hose in a dish to catch the oil.
- Open the shutoff valve with a spanner and let the oil fully drain.
- Shut off the valve, remove the hose and return the cover cap.
- Fill in the oil of specified quality through the filling port on the distribution box (B) until the oil level rises to the center of the viewing glass (A).

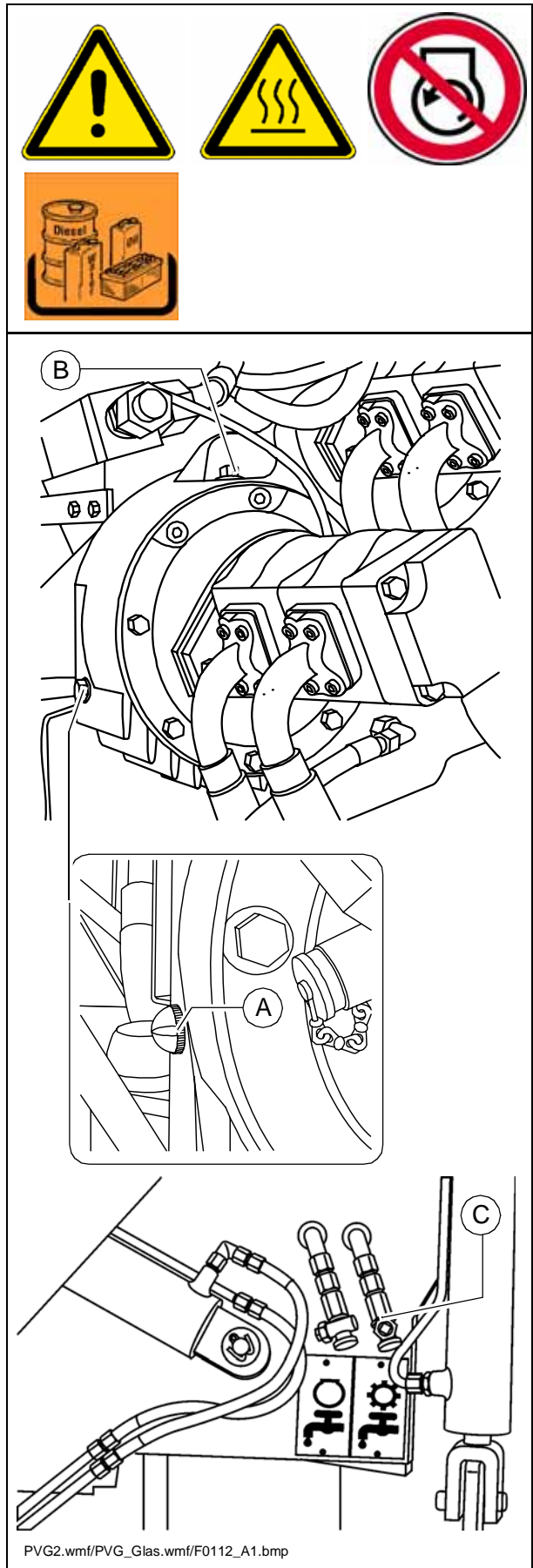

Hydraulic hoses (5)

- Check the condition of the hydraulic hoses specifically.
- Immediately replace the injured hoses.



f The aged hoses may become porous and burst! Risk of accident!

A The numbers stamped in the joints of the hoses state the date of manufacture (A) and the maximum pressure (B) allowed for that hose.

m Do not fit hoses, which were in storage for a long time and check the permitted pressure rating.

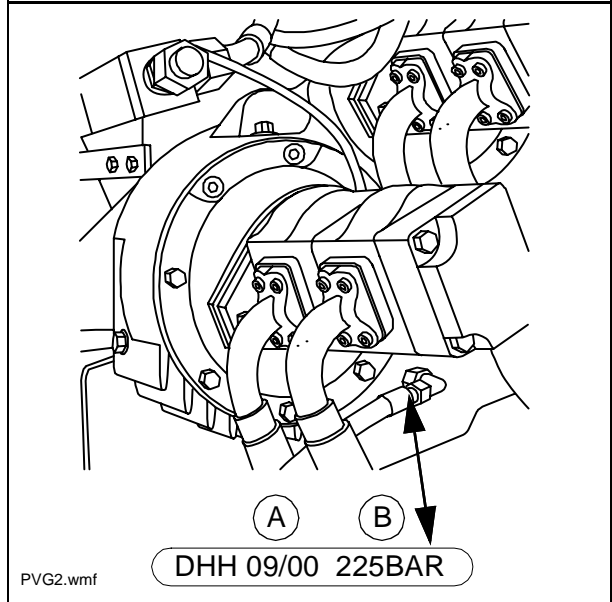

F 7.3 Maintenance - travel drive, steering

1 Maintenance - travel drive, steering

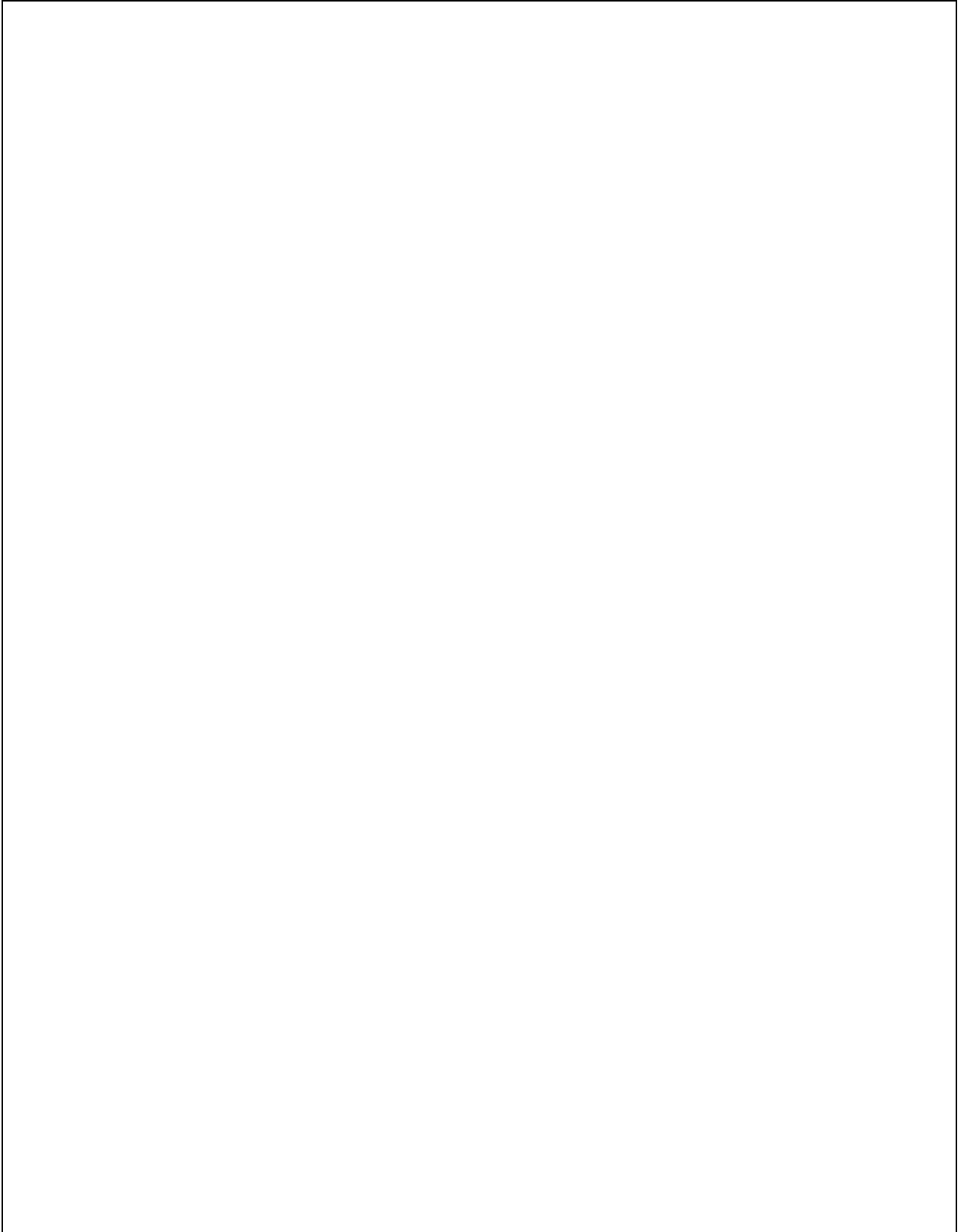

1.1 Maintenance intervals

No.	Interval							Points of maintenance	Remark
	10	50	100	250	500	1000 / year	2000 / 2 years as required		
1	q							- Chain tightness (drive) - Inspection	
							q	- Chain tightness (drive) - setting	
2		q						- Drive shaft oil level check	
							q	- Drive shaft topping up the oil	
						q		- Drive shaft oil change	
3		q						- Air pressure (drive wheels) - check	
							q	- Air pressure (drive wheels) - adjust	
4		q						- Lubrication points - lubrication of axle stubs	
		q						- Lubrication points - lubrication of steering	
		q						- Lubrication points - lubrication of swing axle	
		q						- Lubrication points - lubrication of swing axle	

Maintenance	q
Maintenance during run-in period	g

1.2 Points of maintenance

Chain tightness (drive) - (1)

Checking the track tightness:

m The slack chains may jump off the sprocket wheels and increase wear

m The too tight chains increase the wear of bearings and of the chain,

A The chain is correctly tightened, if the play of the chain is between 20 and 30 mm.



Adjustment of chain tightness:

The grease tensioner of the drive chains can be filled through the grease nipple behind the side lids.

- Open the valve (A) (behind the grease nipple).
- Using the grease gun fill the grease tensioner through the grease nipple (B) until the required chain tightness is achieved.
- Shutoff valve (A)
- Drive the paver forward and backward and measure the adjustment again to check the adjustment.

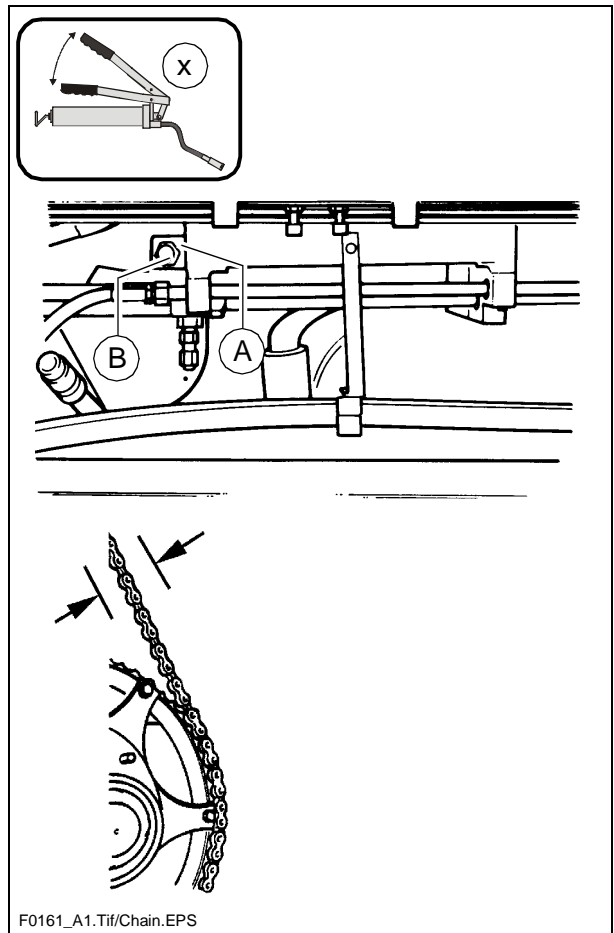

F0161_A1.Tif/Chain.EPS

Drive shaft (2)

- For the **oil level check** unscrew the dipstick (A) on the upper side of the drive shaft.

A The oil level shall be at the upper mark.

For **filling in** the oil:

- Remove the dipstick (A).
- Fill in the specified oil through the filling port (B) until the required filling level is achieved on the dipstick.
- Replace the dipstick (A).

Oil change:

A Change the oil when the engine is at operating temperature

- Remove the cover cap of the oil drain port (C) and screw on the hose provided as an accessory.
- Place the end of the hose in a dish to catch the oil.
- Open the shutoff valve with a spanner and let the oil fully drain.
- Shut off the valve, remove the hose and return the cover cap.
- Fill in the specified oil through the filling port (B) until the required filling level is achieved on the dipstick.
- Replace the dipstick (A).

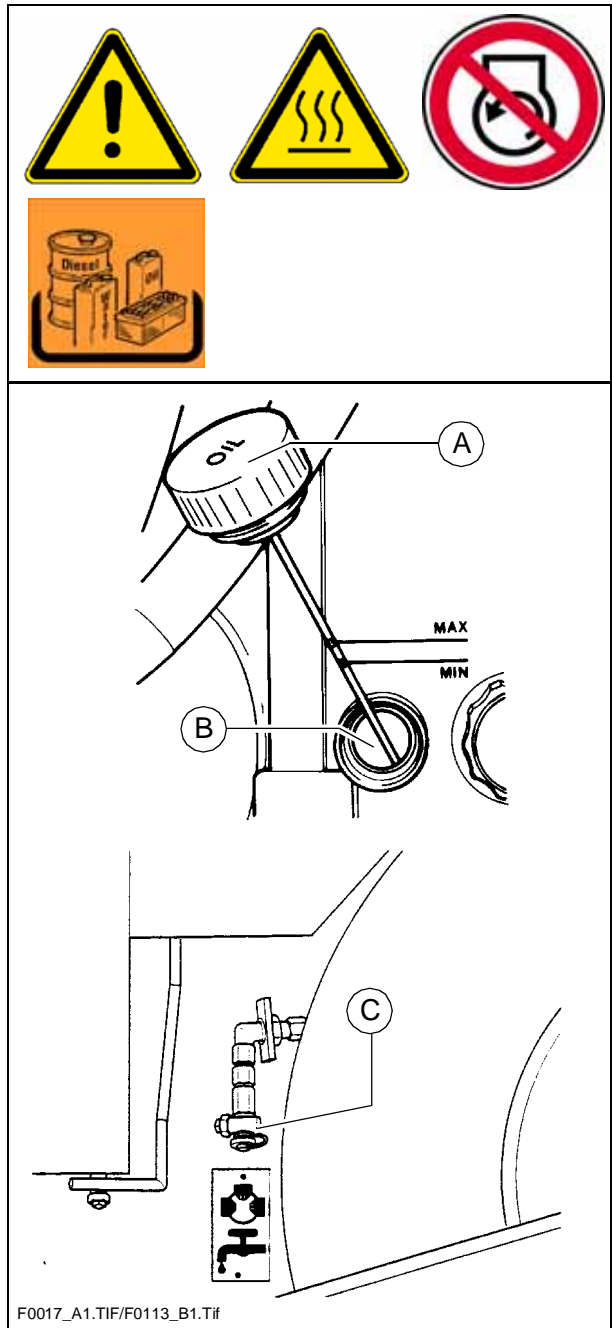

Air pressure (driving wheels) (3)

Check/adjust the belt tightness:

A The required tyre pressure is stamped in each wheel rim and marked by colour (A).

Check the air pressure in valve (B) and adjust as required.

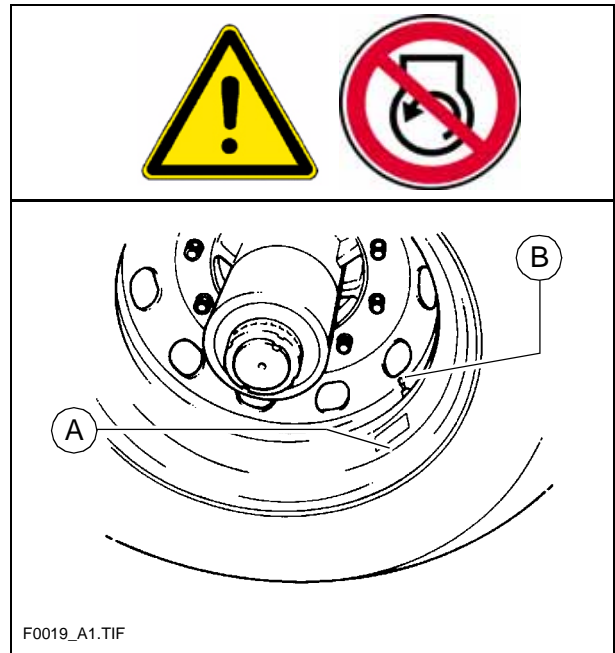

Places of lubrication (4)

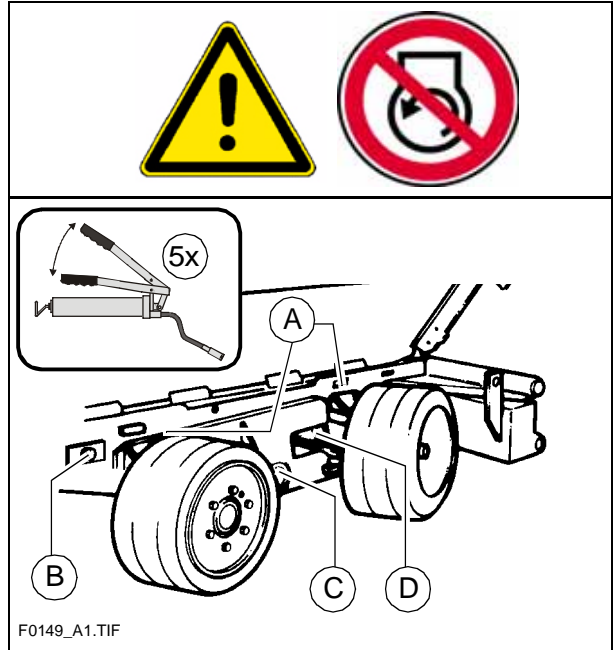

Axle stubs

- A A grease nipple (A) is fitted in each of the four axle stubs.

Steering

- A The grease nipple (B) is located on the **right** side wall and the steering linkage is supplied with grease through a lubrication line.

Swing axle

- A Grease nipple (C) is located on the RH and LH sides on the central bearing of the swing axle.

Wheel bearing

- A The grease nipples (D) are found on the wheel hub at each wheel.
There is no grease nipple in the driven wheel in case of front-wheel drive.

F 8.2 Maintenance - Electronic System

1 Maintenance - Electronic System

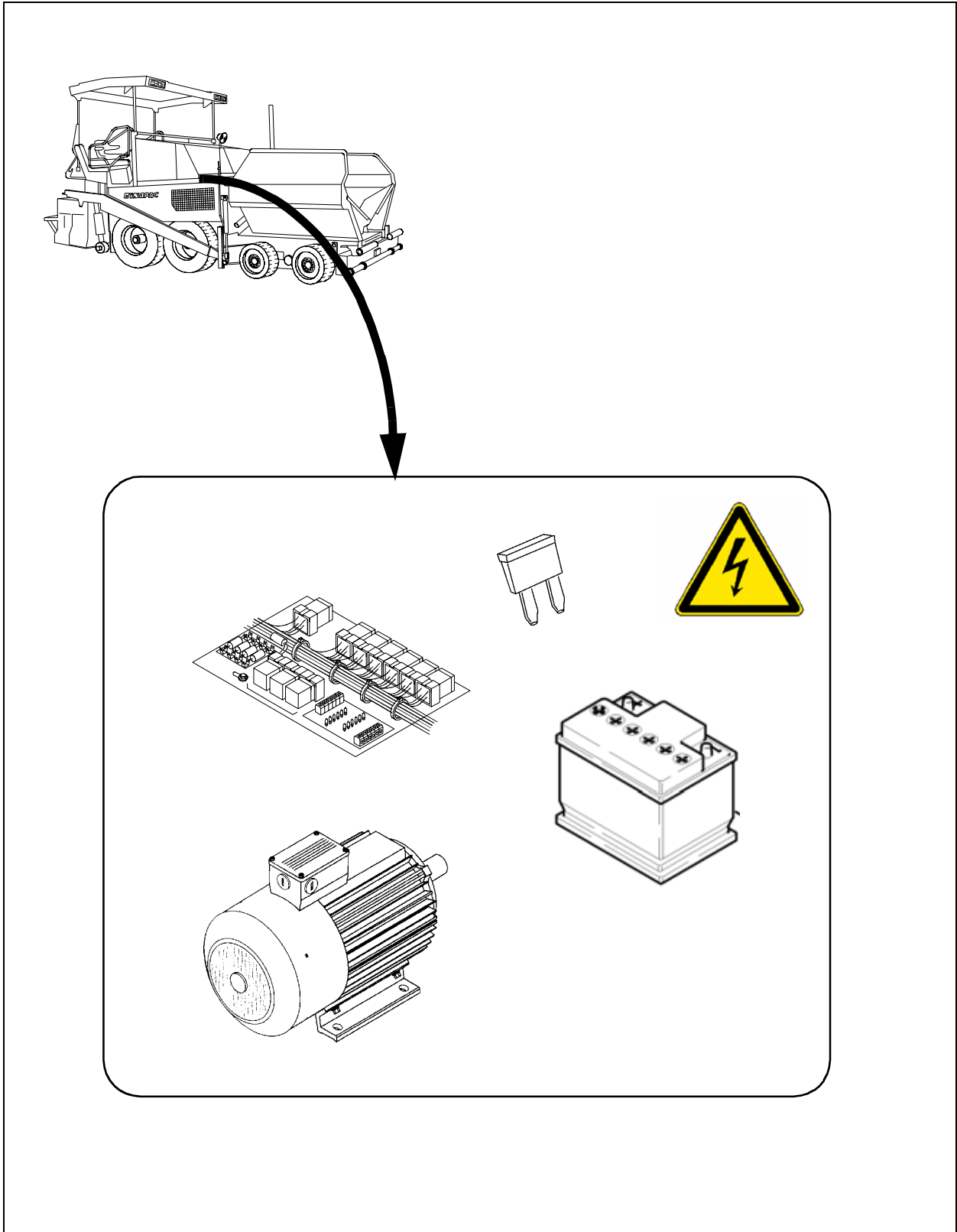

1.1 Maintenance intervals

No.	Interval							Points of maintenance	Remark
	10	50	100	250	500	1000 / year	2000 / 2 years as required		
1			q					Check the level of battery electrolyte	
							q	Top up with ion exchanged water	
			q					Coat the battery poles with grease	

Maintenance	q
Maintenance during run-in period	g

No.	Interval								Points of maintenance	Remark
	10	50	100	250	1000	5000	20000	as required		
2	q								- Generator Operational checking of the insulation supervision of electrical equipment	Also see the operation manual of the screed
				q					- Generator Visual checking for pollution or damage - Check the cooling air openings for pollution or clogging, clean as required.	(○)
						q			- Generator Check the ball bearings „by listening“ and replace them as required.	(○)
							q	q	- Generator Replacement of ball bearings	(○)
				q					- Generator Check the drive belts (○) for injury and replace them as required.	(○)
				q					- Generator Drive belts (○) - check tightness and adjust as required.	(○) Only on version with V-belt!
					q				- Generator Replacement of drive belts (○)	(○)

Maintenance	q
Maintenance during run-in period	g

No.	Interval							Points of maintenance	Remark
	10	50	100	250	500	1000 / year	2000 / 2 years		
3								q	Electric fuses

Maintenance	q
Maintenance during run-in period	g

1.2 Points of maintenance

Batteries (1)

Maintenance of storage batteries

The batteries are filled with the appropriate volume of electrolyte in the factory. The electrolyte level shall be up to the top mark. Top up with ion exchanged water only, when required!

The shoes shall be free of oxide and coated with special battery protection grease.

m

When removing the batteries always separate the minus pole first and avoid short circuit between the battery poles.

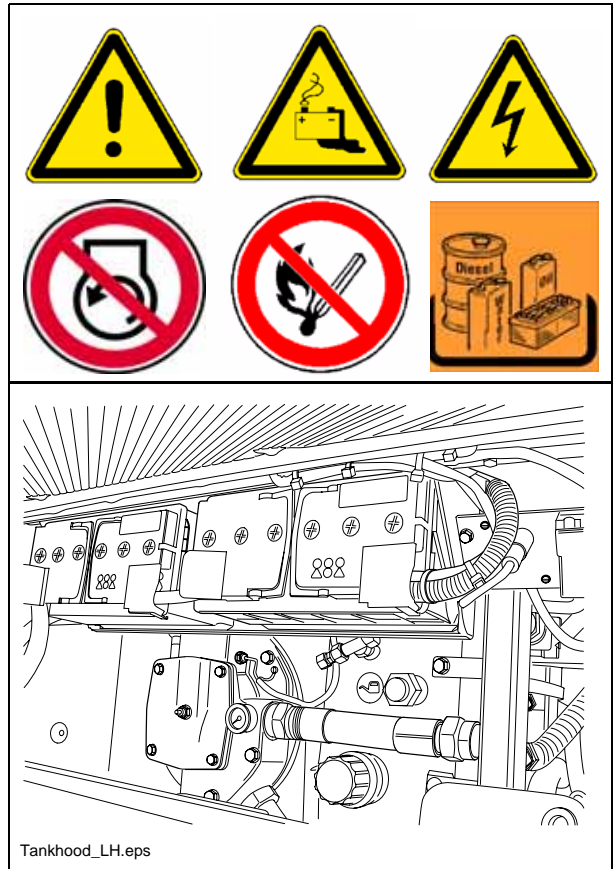

Generator (2)

Checking of operation of the insulation monitoring

A Check insulation daily with operating machine and switched on connection sockets.

- Turn on the electrical equipment with switch (1), control light (2) comes on.
- Press testing button (3) and the inscription „Isolationsfehler - Insulation Fault“ shall come on.
- Depress the button clear (4) and the insulation fault inscription will go dark.

f If the test is completed successfully, work can proceed with the electrical system and external consumers can be used.

If the „Insulation Fault“ control light indicates a fault already before pressing the control button, then work cannot proceed with the electrical system and the external consumers. In case of insulation fault the connection sockets are automatically turned off.

Work with the electric system cannot proceed if the simulation does not indicate a failure.

f In case of failures, the electric equipment needs to be tested and repaired by an electrician. With these devices and the equipment work can be resumed only after such test and repair.

A **Danger from electric voltage**
Failure to comply with the safety precautions and safety regulations can result in electrical shock injuries from the electrical system.

Danger to life!

All maintenance and repair work on the electrical system must always be carried out by an electrician!

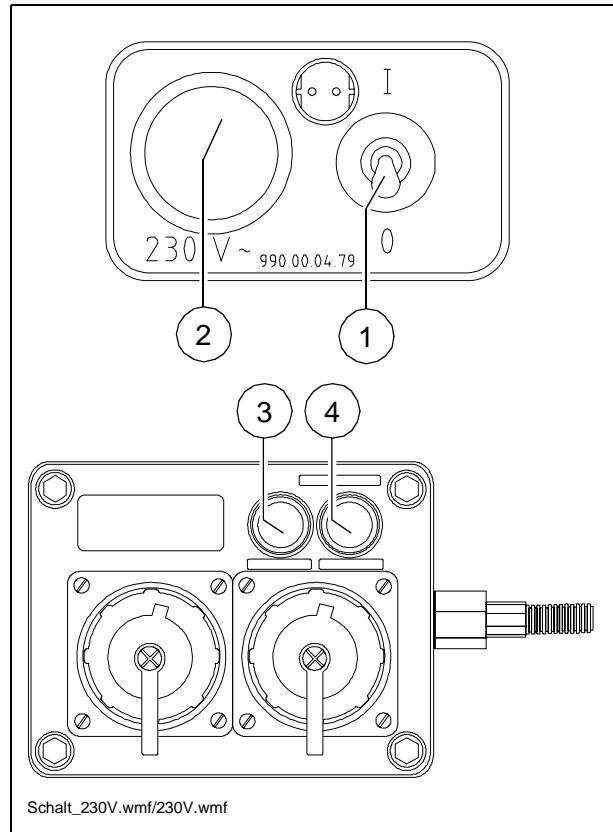

Checking of ball bearings / Replacement of ball bearings

A

Report the displayed fault code to the customer service of the paver finisher and they will discuss with you the steps to be taken.



Drive belts (V-belt)

Checking belt tension

The tightness of each belt shall be inspected with a tightness checking instrument.

Specified tension:

- in case of first assembly: 550 N
- after the run-in period / maintenance interval: 400N

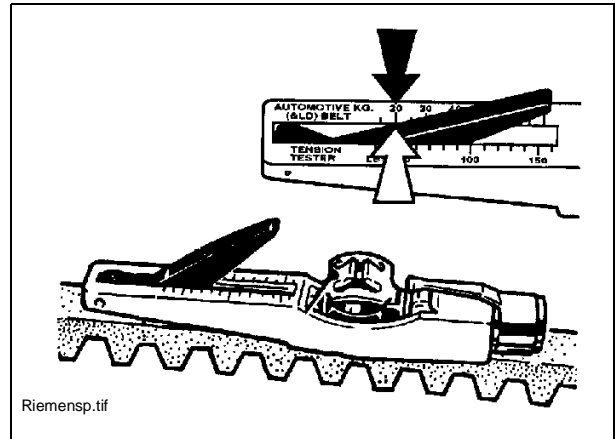

A Instructions for checking of tightness in the description of the tightness measuring instrument.

A The tightness measuring instrument can be ordered according to the Article No. 532.000.45!

Adjustment of belt tension

- Untighten locking screw (A) so that the bracket (B) of the tightening roller comes to position zero (scale (C) = 0°).
- For the adjustment of the locking device loosen or turn the appropriate nut (D) or counter-nut (E), until the tightening roller contacts the loosened upper belt.
- Turn the bracket of the tightening roll (B) to adjust the correct tightness, towards the upper belt (scale (C) = 15°).
- Retighten locking bolt (A).
- Retighten the previously loosened nut (D) or (E).

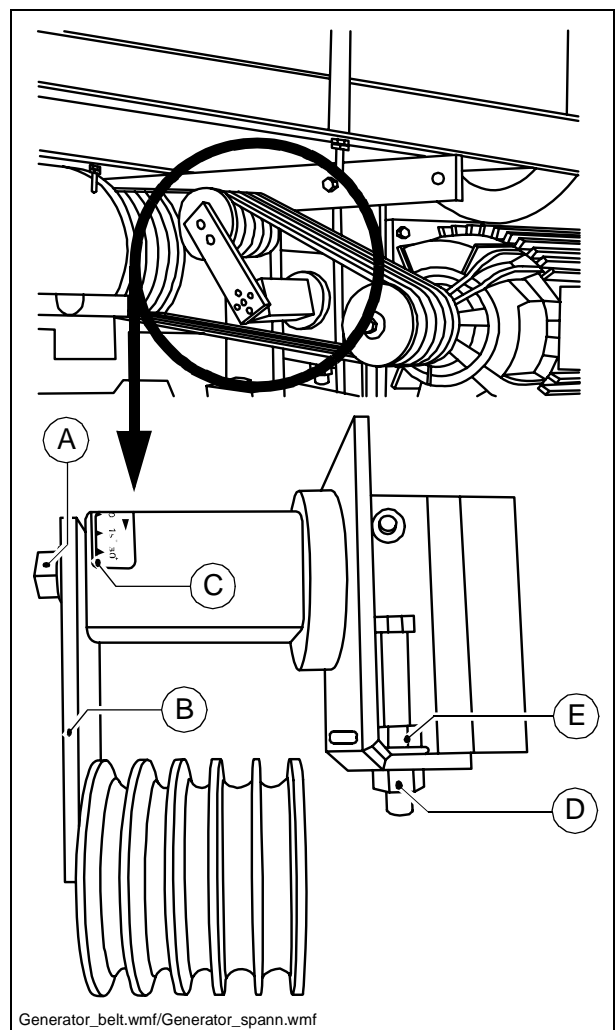

Replacement of belt

- Reduce the belt tightness on the adjusting device so that the belt can be removed from the pulley.
- Mount the new belt and adjust tightness again.

A Always replace the belts in sets.

Drive belt (toothed belt)



Replacement of belt

- Unfasten both lock nuts (A) from the clamping lock.
- Rotate and open clamping lock (B) until belt (C) can be replaced.

A Pre-tension newly fitted belt using clamping lock (B).

- Checking / adjusting belt tension

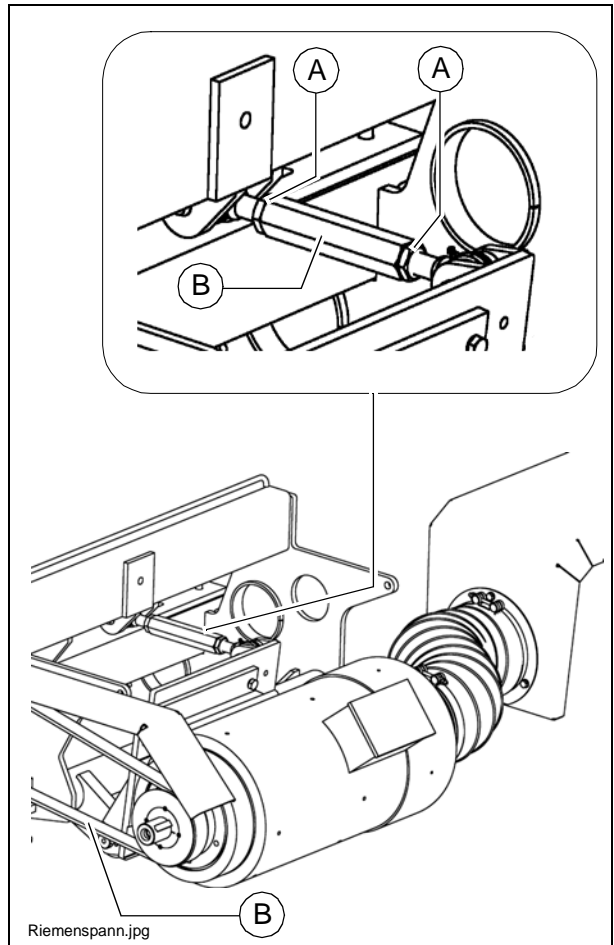

Checking / adjusting belt tension:

A The tension of the V-belt must be checked and set after the belt has been replaced.

- The tension of the belt can only be adjusted using a pre-tensioning test device.

Specified belt tension levels:

- **Generator 17KVA:**
 - Deflection force, min: 101.4N
 - Deflection force, max: 110.6N
 - Belt deflection approx. 9.9mm
- **Generator 20KVA:**
 - Deflection force, min: 72.4N
 - Deflection force, max: 79.0N
 - Belt deflection approx. 5.4mm
- **Generator 28KVA:**
 - Deflection force, min: 92.2N
 - Deflection force, max: 100.5N

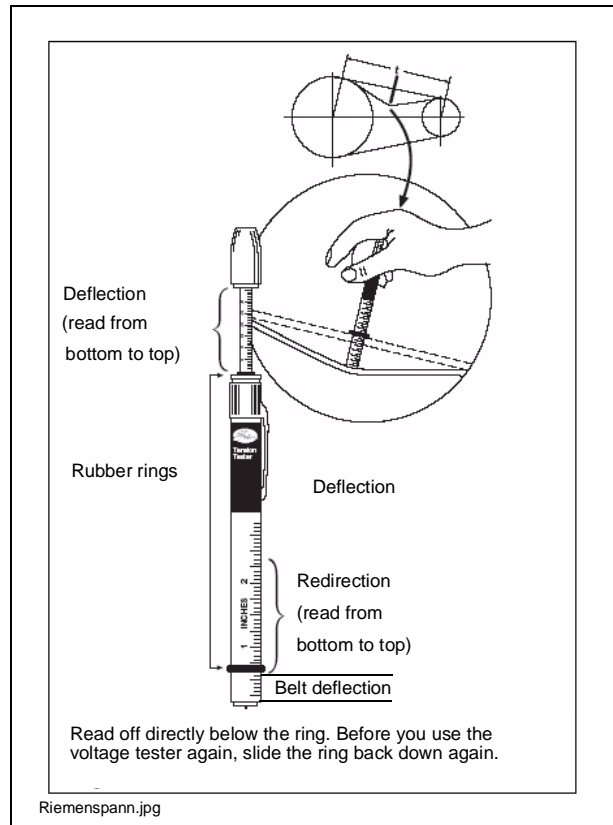

A Belt deflection approx. 5.4mm

If necessary, adjust the belt tension:

- Set belt to correct tension using clamping lock (B).
- Retighten both lock nuts (A).

A Further instructions for checking of tension - see description of the belt pre-tensioning test device.

A A belt pre-tensioning test device can be ordered from Dynapac as a spare part! Item number on request.

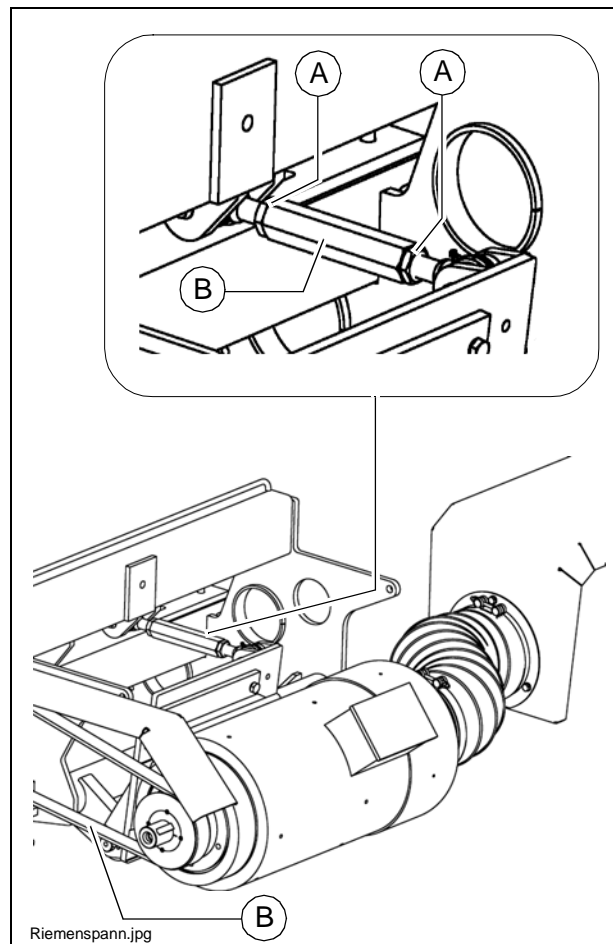

Electric fuses (3)

Type of machine: Conventional elec-tronics

Terminal box

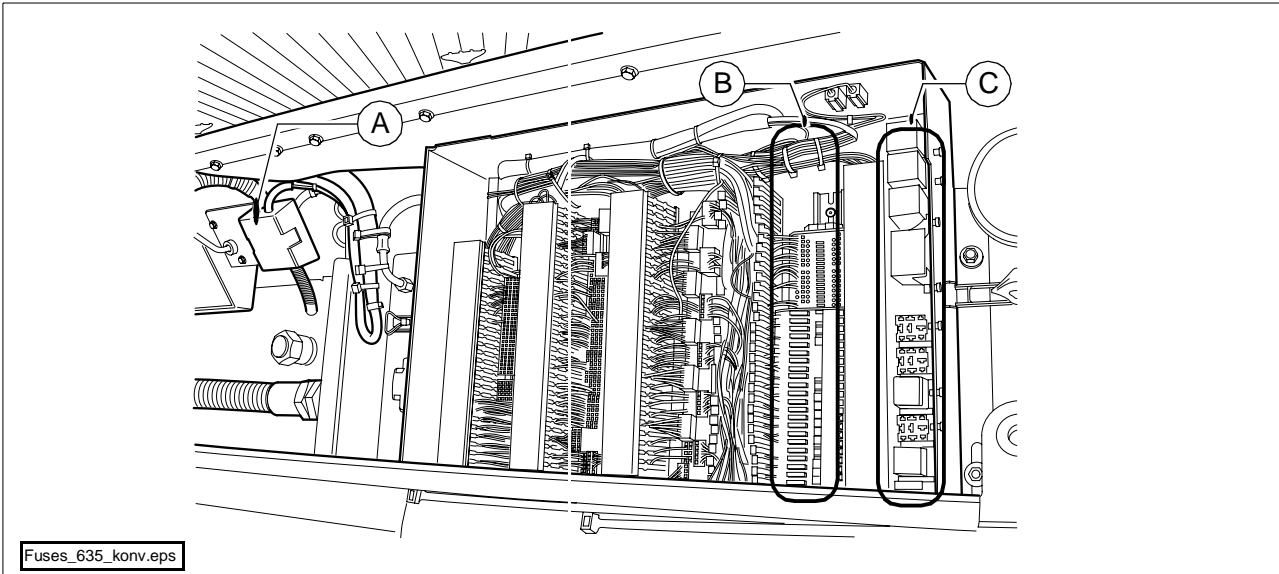

A	Main fuses
B	Fuses in terminal box
C	Relays in terminal box

Main fuses (A)

F.		A
3.1	Lighting, engine	50
3.2	Lighting, engine	50

Fuses in terminal box (B)

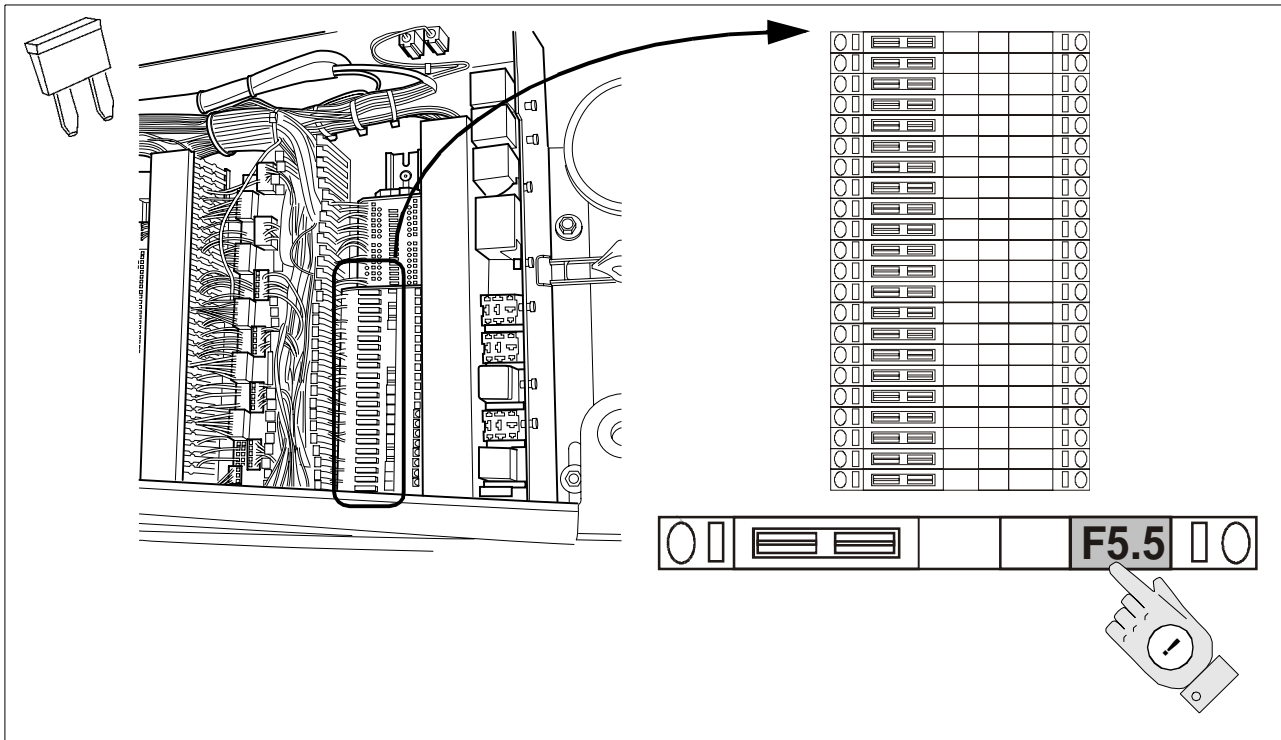

F.		A
5.1	Travel drive	5
5.2	Differential lock, ASC	10
5.3	Temperature control, electric heating	7.5
5.4	Gas heater	10
5.5	Integrated receptacles	10
5.6	Integrated receptacles	10
5.7	Integrated receptacles	10
5.8	Integrated receptacles	10
5.9	Engine start	10
41	Engine feedback control	25
50	Main fuse for auxiliary functions	30
51	Spraying system	3
52	Emulsion spraying system	3
53	Diesel tank filler pump	5
54	Rotary beacon	3
55	Lighting on glassfibre-reinforced roof	10
56	Asphalt fume control system or xenon light (○)	3
59	Working lights (○)	15
84	Seat heating	10
85	Windscreen wiper	7,5
86	Reserve	10
89	Travel drive (brake light)	2

Fuses on operating panel

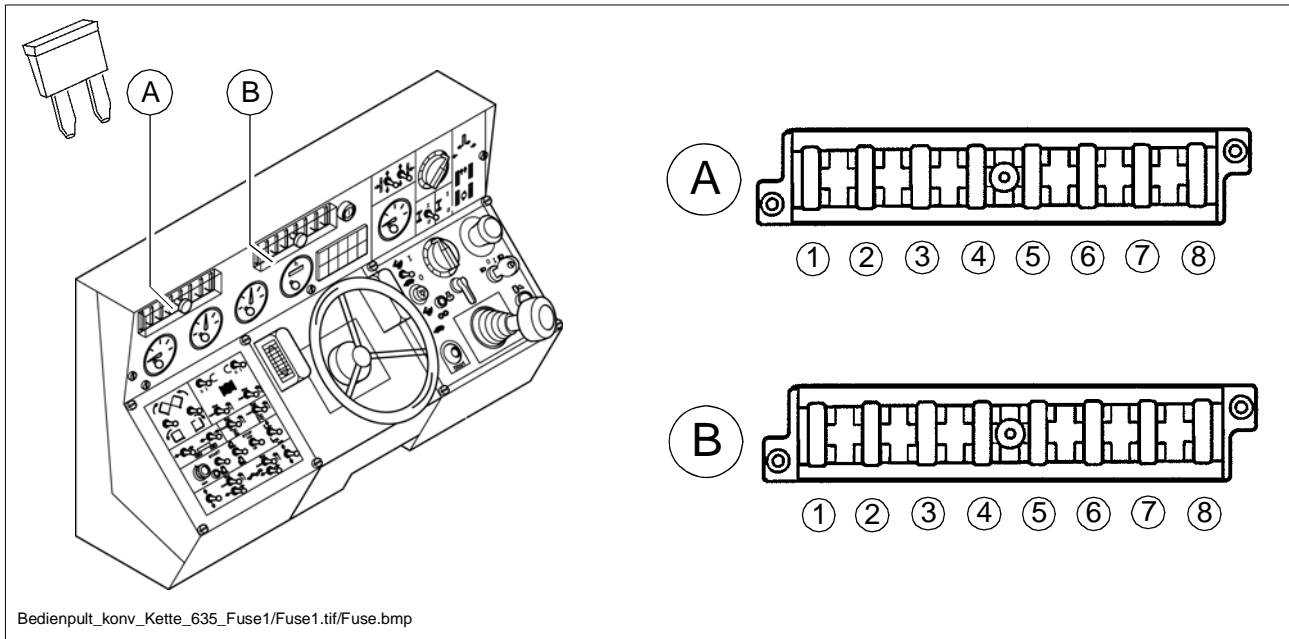

Fuse carrier (A)

No.	F.		A
1.	1.1	Engine start, start interlock, idle speed, reverse buzzer (○), reversing hazard flasher (○)	5
2.	1.2	Locking relay, monitoring equipment, sensors, differential lock	3
3.	1.3	Levelling unit, screed stop	5
4.	1.4	Conveyor, auger, right	7.5
5.	1.5	Conveyor, auger, left	7.5
6.	1.6	Tamper, vibration, ASC On/Off, truck hitch Open/Close, tamper overrun	3
7.	1.7	Hoppers, lifting/lowering screed, extending/retracting screed, power supply screed, compactor lift (○), moving cab (○), lifting/lowering auger (○)	10
8.	1.8	Emergency stop, EMR On/Off	7.5

Fuse carrier (B)

No.	F.		A
1.	2.1	Hazard warning flashers, flasher, left	5
2.	2.2	Hazard warning flasher, flasher, right, auxiliary functions, horn	3
3.	2.3	Crowning, brake light	3
4.	2.4	High-beam headlights, left/right	7,5
5.	2.5	Low-beam headlights, right	3
6.	2.6	Low-beam headlights, left	3
7.	2.7	Parking lights, right	3
8.	2.8	Parking lights, left, instrument panel lighting, instrument lighting	3

Relays in operating panel

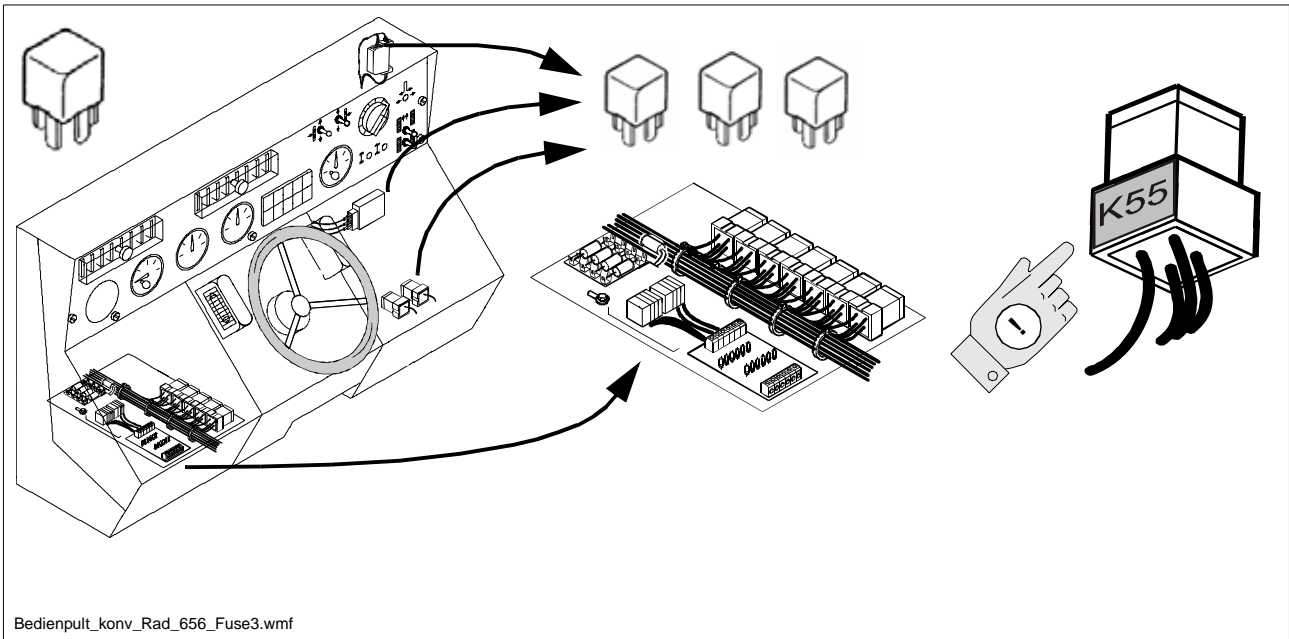

Relays

K	
11	Idling speed
12	Conveyor/auger, left
13	Conveyor/auger, right
17	Screed function
32	Flasher sensor (lighting)
33	Engine stop
39	Start interlock
80	Timer relay, revers. conveyor, right
81	Timer relay, revers. conveyor, right
149.1	Priority circuit for extending/retracting screed, left
149.2	Priority circuit for extending/retracting screed, right
133	Function interlock (Italy)

Type of machine: PLC electronics

Terminal box

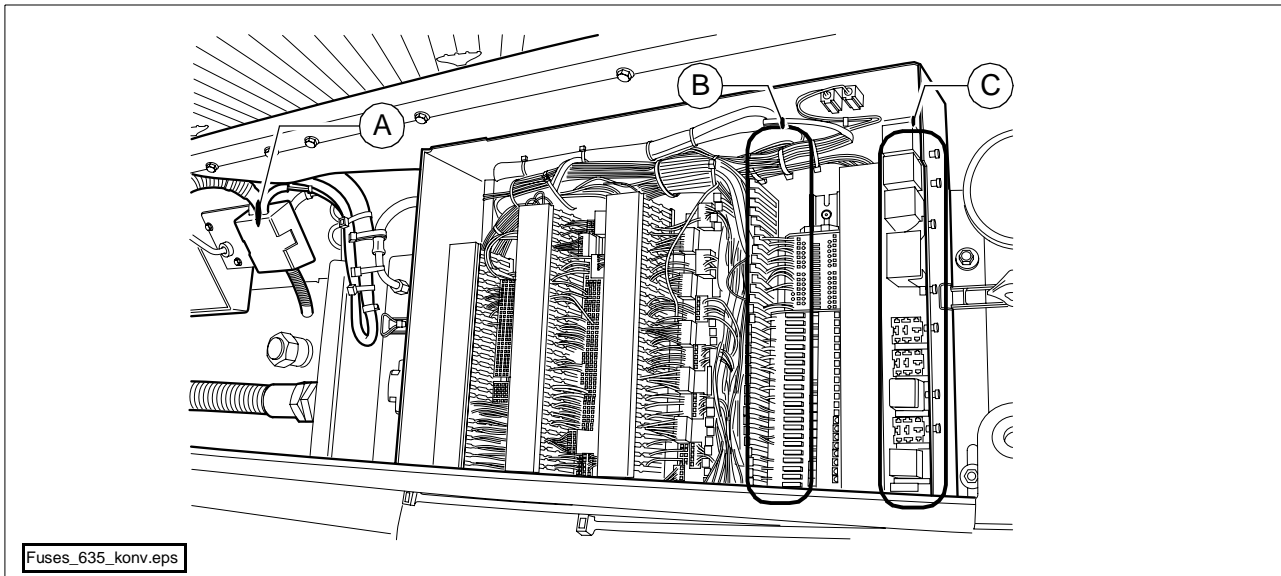

Fuses_635_konv.eps

A	Main fuses
B	Fuses in terminal box
C	Relays in terminal box

Main fuses (A)

F.		A
3.1	Lighting, engine	50
3.2	Lighting, engine	50

Fuses in terminal box

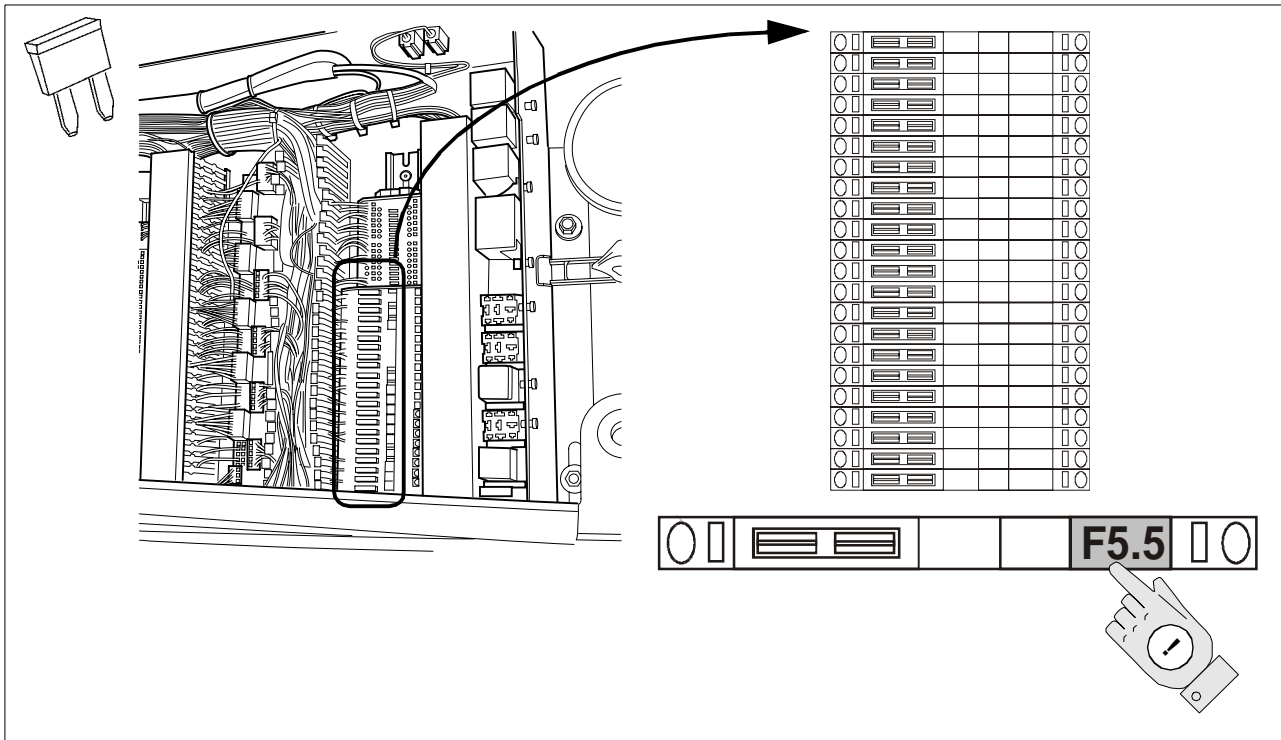

F.		A
5.1	Travel drive	5
5.2	Differential lock, ASC	10
5.3	Electric heating	10
5.4	Power supply to screed, gas heater	10
5.5	Integrated receptacles	10
5.6	Integrated receptacles	10
5.7	Integrated receptacles	10
5.8	Integrated receptacles	10
5.9	Engine start	10
7.1	Slave A31	5
7.2	Slave A32	5
7.3	Slave A33	5
7.4	Slave A34	5
7.5	Slave A35	5
7.6	Slave A36	5
41	Engine feedback control	25

F.		A
51	Spraying system	3
52	Emulsion spraying system	3
53	Diesel tank filler pump	5
54	Rotary beacon	3
55	Lighting on glassfibre-reinforced roof	10
59	Working lights (○)	15
80	Power supply, Master A1	7.5
82	Particulate filter (○)	3
83	Asphalt fume control system (○)	3
84	Seat heating	10
85	Windscreen wiper	7,5
86	Reserve	10
88	Power supply, Master A1	7,5

Relays in terminal box (C)

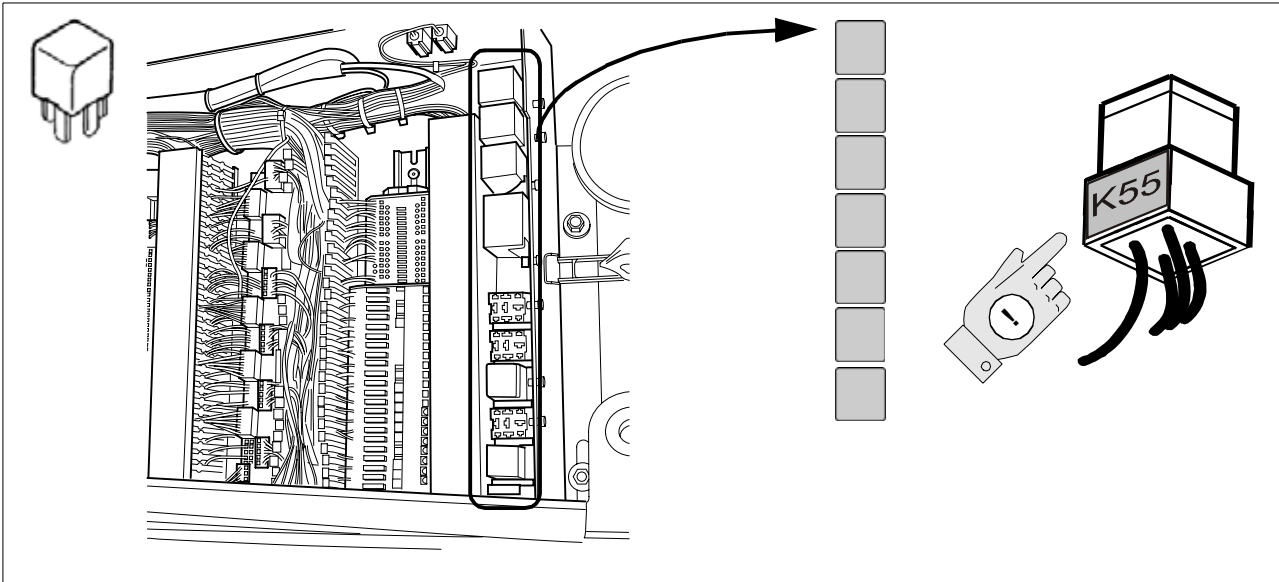

K	
15	Engine start
18	Impulse sensor
24	Auxiliary oil cooler
30	Horn
42	Travel drive
47	Start interlock
49	Reverse buzzer
52	Engine changeover, travel drive
53	Engine changeover, travel drive
94	Power supply to terminal 15, engine
145	Engine feedback control

Fuses on operating panel

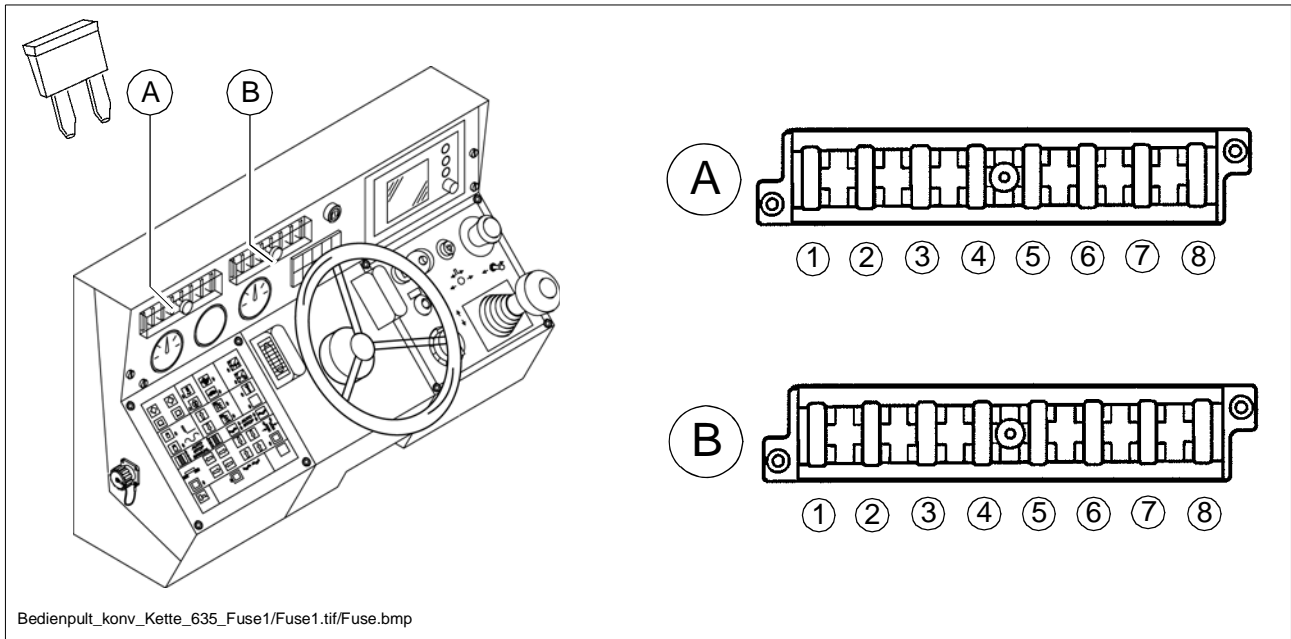

Fuse carrier (A)

No.	F		A
1.	1.1	Emergency stop	7.5
2.	1.2	Monitoring equipment, relay batt. 15+,, engine sensors, differential lock	3
3.	1.3	Display power supply	3
4.	1.4	Keyboard power supply	3
5.	1.5	Free	
6.	1.6	Free	
7.	1.7	Screed power supply (○), crowning adjustment (○), moving cab	5
8.	1.8	Free	

Fuse carrier (B)

No.	F.		A
1.	2.1	Hazard warning flashers, flasher, left	3
2.	2.2	Hazard warning flashers, flasher, right, horn, reverse buzzer	5
3.	2.3	Footbrake and handbrake, crowning adjustment	3
4.	2.4	High-beam headlights, left/right	7,5
5.	2.5	Low-beam headlights, right	3
6.	2.6	Low-beam headlights, left	3
7.	2.7	Parking lights, right	3
8.	2.8	Parking lights, left, instrument panel lighting Instrument panel lighting	3

F 9.0 Maintenance - Points of lubrication

1 Maintenance- Points of lubrication

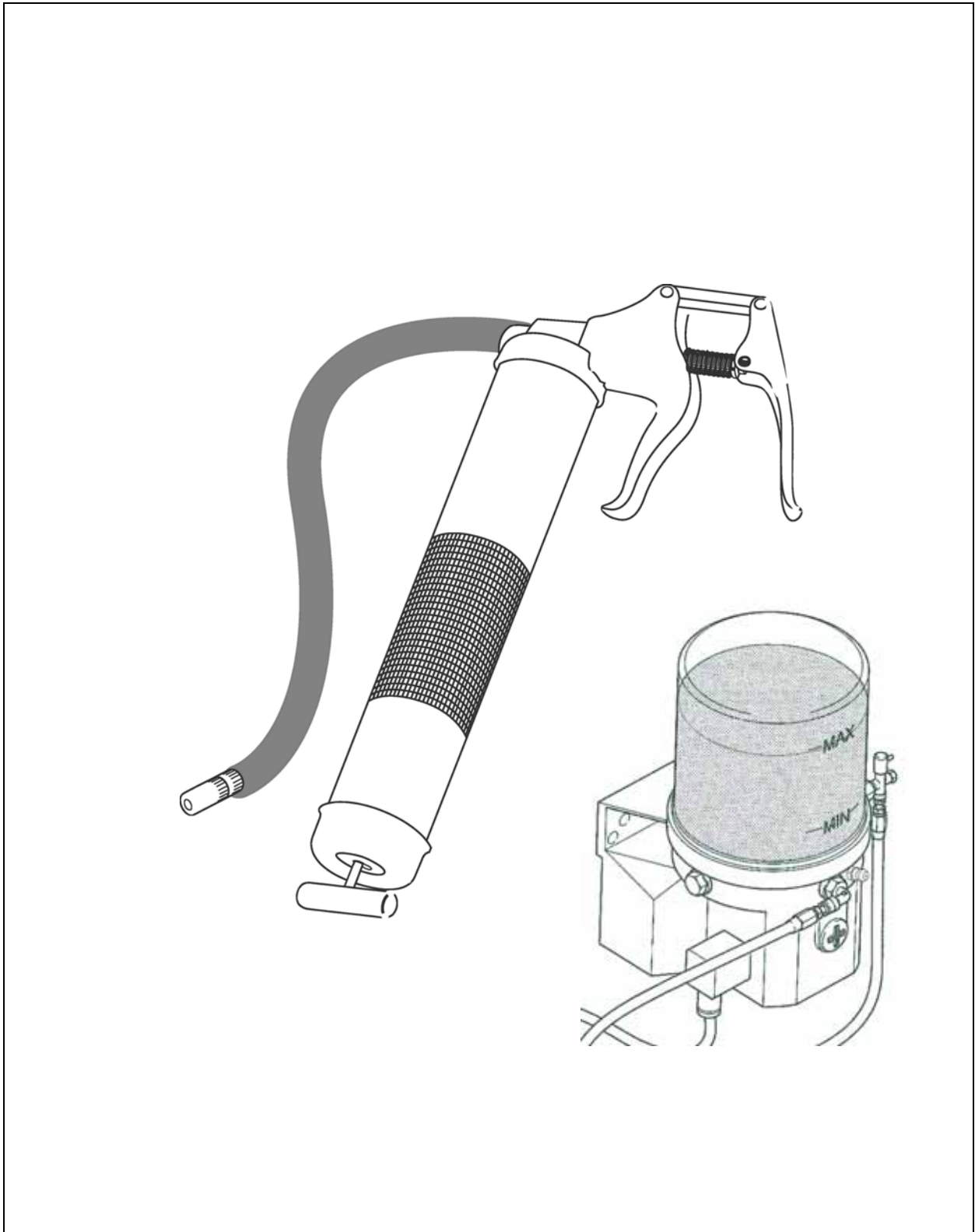

F_9.0_01_GB.fm 1-8

- A The information related to the lubrication points of the various sub-units are included in the specific maintenance descriptions and additional reading is recommended as follows.
- A In case of applying a central lubrication unit (○) the number of the lubrication points may differ from the data provided in the description.

1.1 Maintenance intervals

No.	Interval							Points of maintenance	Remark
	10	50	100	250	500	1000 / year	2000 / 2 years as required		
1	q							- Check the filling level of the lubricant tank	(○)
							q	- Fill up the lubricant tank	(○)
							q	- Vent the central lubrication unit	(○)
	q							- Check the pressure limiting valve	(○)
							q	- Check the leakage of the lubricant at the consumer unit	(○)
2	q							- Bearings	

Maintenance	q
Maintenance during run-in period	g

1.2 Points of maintenance

Central lubrication (1)

Danger of injuries!

- f Do not reach into the tank when the pump is running.
- f Operate the central lubrication system with a mounted safety valve only!
- f During operation do not perform maintenance operations on the safety valve!
- f The lubricant ejected may cause injuries as the equipment operates under high pressure!
- f Make sure that the starting of the diesel engine should be prohibited while work is performed on the equipment!
- f Observe the rules applicable to the operation of the hydraulic equipment!
- m Take care of perfect cleanliness when work is performed on the central lubrication system.



The lubrication points of the following units can be provided with grease through the central lubrication system:

- Feeder
- Auger
- Steering, axles (wheel type paver finisher)

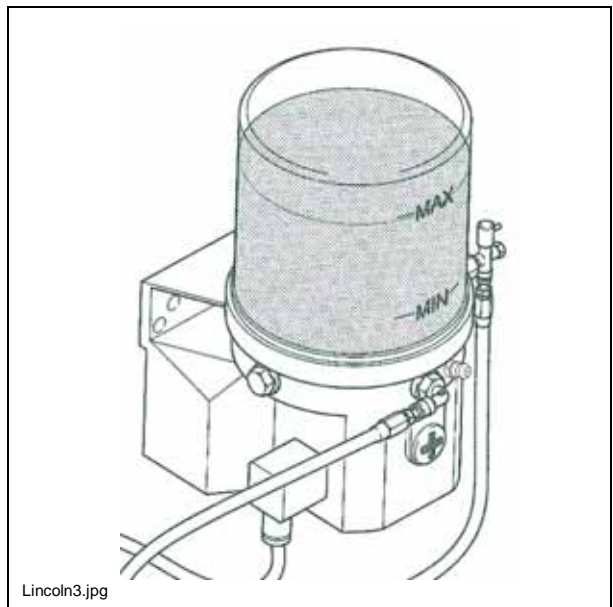

Central lubrication unit Check the filling level

A The lubrication tank shall always be filled so that the system could not „run dry“ and the proper lubrication of the points of lubrication is ensured and there is no need for a time consuming venting operation.

- Always keep the filling level above the „MIN“ mark of the tank (a).

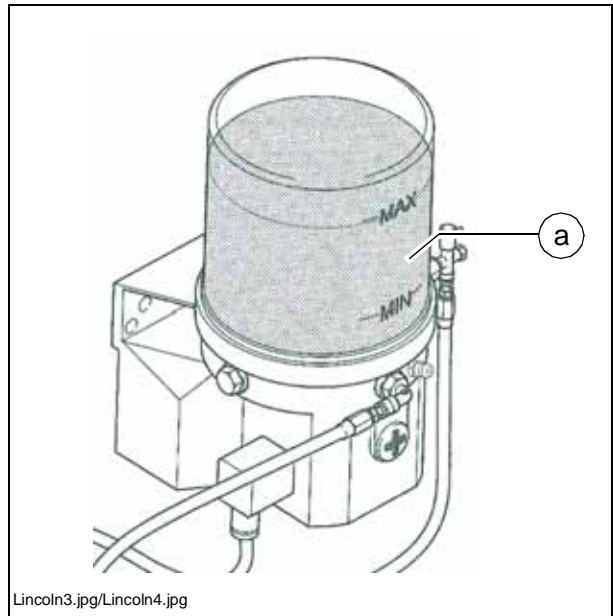

Fill up the lubricant tank

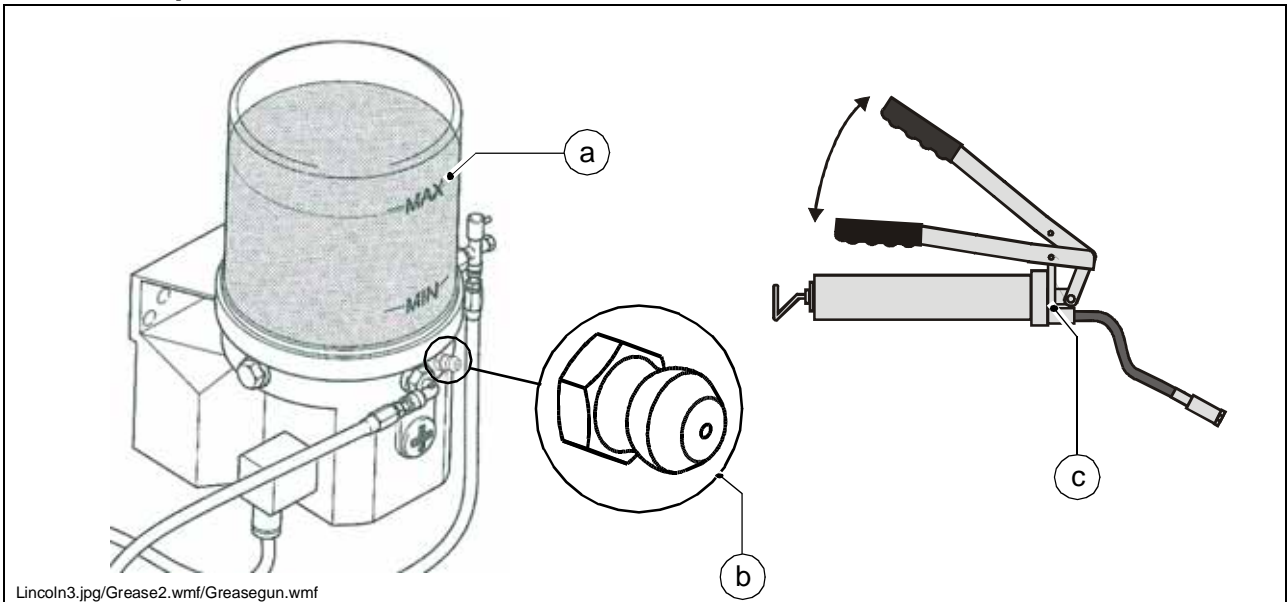

- A grease nipple (b) is mounted for filling on the lubricant tank (a).
- Connect the grease gun (c) supplied with the machine to the filling head (b) and fill the lubricant tank (a) until the MAX mark.

A In case of an empty lubricant tank the pump may work for even 10 minutes before it reaches its full delivery performance after filling.

Vent the central lubrication unit

The venting of the lubrication system becomes necessary if the central lubrication unit was operated with an empty lubrication tank.

- Untighten the main line (a) of the lubrication pump at the flow divider (b).
- Start the operation of the central lubrication unit with the refilled lubricant tank (c).
- Leave the pump running until grease is squeezed from previously untightened main line (a).
- Retighten the main line (a) at the flow divider.
- Remove all the manifold lines (d) at the flow divider.
- Reconnect again the manifold lines once lubricant is discharged through them.
- Check the tightness of all the connections and lines.

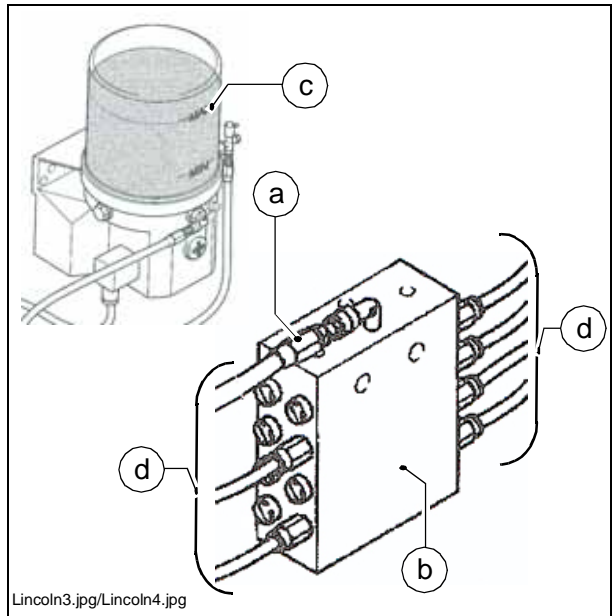

Check the pressure limiting valve

m

If lubricant is discharged at the pressure limiting valve (a), this refers to failure in the system.

The consumers receive not enough lubricant.

- Disconnect the manifold lines (b), which run from the flow divider (c) to the consumers, one after the other.
- If lubricant is ejected from one of the disconnected distribution pipes (b) under pressure, then the clogging, which led to the tripping of the pressure limit valve, must be searched for in this lubrication circuit.
- After correcting the fault and the repeated connection of all the lines, check once again for lubricant discharge from the pressure limit valve (a).
- Check the tightness of all the connections and lines.

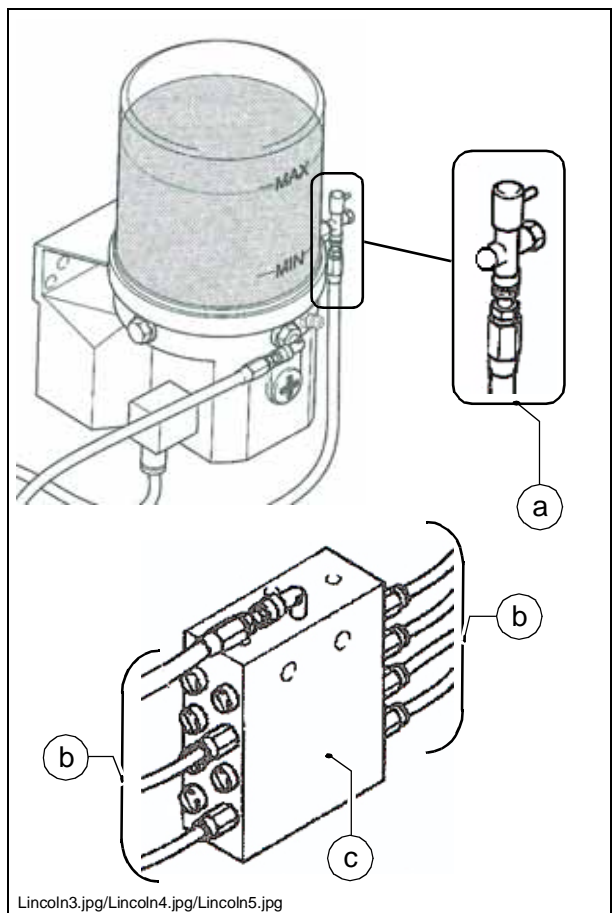

Check the leakage of the lubricant at the consumer unit

Check the continuity of all the lubrication canals at the consumers.

- Disconnect the lubrication pipe (a) and fit a standard grease nipple (b).
- Connect the grease gun (c) supplied with the machine to the grease nipple (b).
- Keep on operating the grease gun until lubricant is visibly discharged.
- If necessary, eliminate the faults of the lubricant flow.
- Refit the lubricant pipelines.
- Check the tightness of all the connections and lines.

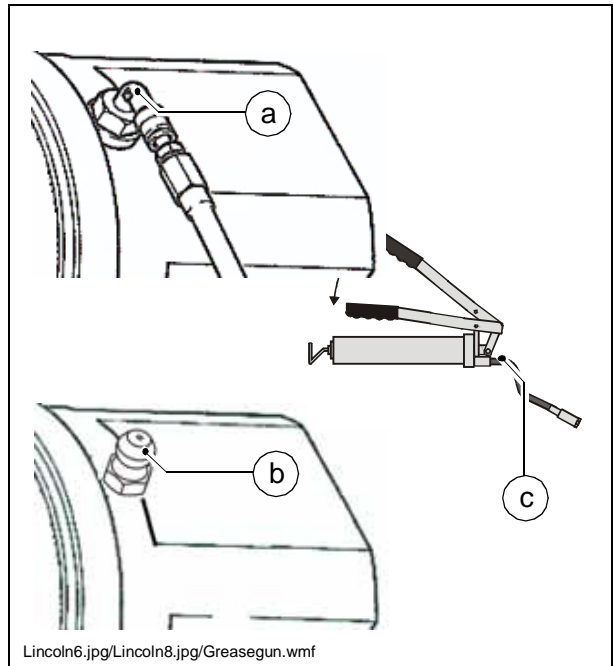

Bearings (2)

There are grease nipples on the bearing points of the hydraulic cylinder (one each, at the top and bottom) (a).

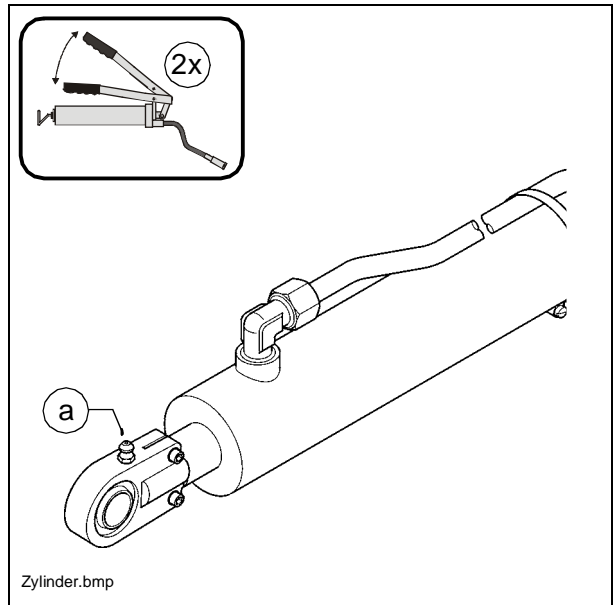

F 10.0 Checks, decommissioning

1 Tests, check-up, cleaning, stopping

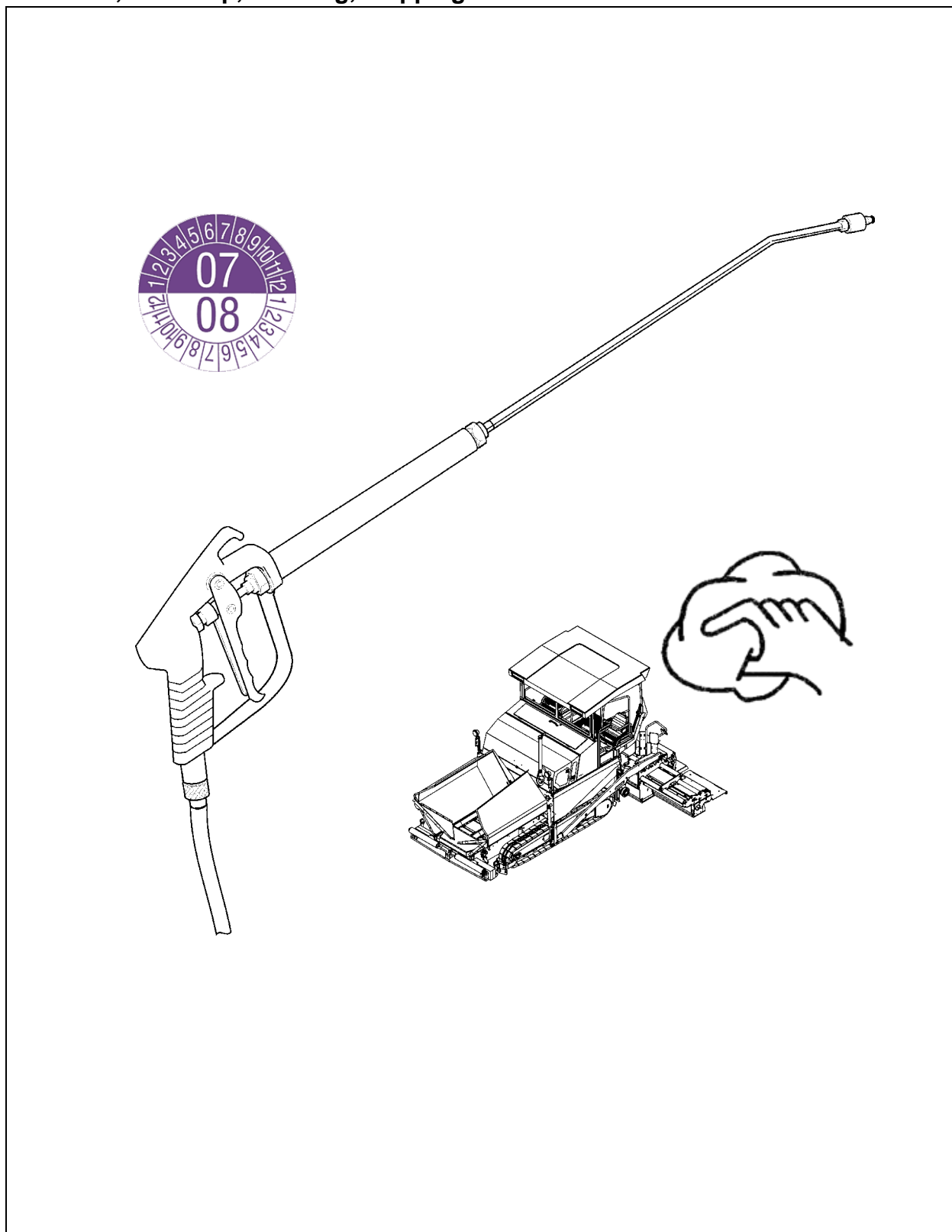

1.1 Maintenance intervals

No.	Interval							Points of maintenance	Remark
	10	50	100	250	500	1000 / year	2000 / 2 years as required		
1	q							- General observation	
2						q	q	- Checks by a specialist	
3							q	- Cleaning	
4							q	- Conservation of paver finisher	

Maintenance	q
Maintenance during run-in period	g

2 General observation

The daily practice includes the walk around the machine with checking the following items:

- Are there injuries on the parts or control elements?
- Are there leaks on the engine, the hydraulics, the gear box, etc.?
- Are all the locking points secure (conveyor, auger, screed)?

m Repair the detected faults immediately in order to avoid risks of accidents and environmental pollution!

3 Checks by a specialist

A Subject the paver finisher, the screed and the optional gas or electric operated equipment to checks by a specialist

- as required (according to the circumstances of application and operating conditions),
- however, minimum once a year, so that the machine retains its reliable operating condition.

4 Cleaning

- Clean all parts which come into contact with the material to be laid.
- Spray the polluted parts with the separating agent spray equipment (○).

m **Before** cleaning with high pressure jet, lubricate all the bearings with grease as specified.

- Clean the machine with water after laying mineral mixes, lean concrete etc.

m Do not spray water on the bearings, electric or electronic parts.



- Remove the residue of the material laid.

m **After** cleaning with high pressure jet, lubricate all the bearings with grease as specified.

f Risk of slipping! Take care of the cleanliness of the walkways and steps, make sure that they are free of grease and oil.



5 Conservation of paver finisher

5.1 Downtime up to 6 months

- Stop the machine in a place protected from intensive sunshine, wind, moisture and frost.
- Lubricate all the lubrication points with grease as specified, use the optional central lubrication unit as appropriate.
- Change the oil in the Diesel engine
- Tightly seal the muffler of the exhaust pipe.
- Remove the batteries, charge and store them at room temperature in well ventilated premises.

m Recharge the dismantled batteries every 2nd month.

- Protect all shiny metal surfaces, e.g. piston rods of the hydraulic cylinder against corrosion using an appropriate agent.
- If the machine cannot be halted in a closed hall or under a shed, it must be covered with an appropriate canvas. In each case all the air inlets and outlets shall be tightly sealed using plastic film and adhesive tape.

5.2 Downtime between 6 months and 1 year.

- Perform all operations described for „Downtime up to 6 months“.
- After draining the engine oil, fill the engine with conservation oil permitted by the manufacturer of the engine.

5.3 Re-commissioning:

- Perform the operations opposite to what were described in the section „Downtime“.

F 11.3 Lubricants and operating substances

1 Lubricants and operating substances

m Use only the lubricants listed below or comparable qualities of well-known brands.

Use only clean containers (inside and outside) for pouring oil or fuel in.

A Pay attention to the correct filling volumes (see the section "Filling volumes").

m Incorrect oil or lubricant levels promote rapid wear and cause the paver finisher to fail.

m Never mix synthetic oils with mineral oils!

	BP	Esso	Total Fina (Total)	Mobil	Renault	Shell	Wisura
Grease	BP Multi-purpose grease L2	ESSO Multi-purpose grease	Total Multis EP 2	Mobilux 2 Mobilplex 47	Multi-purpose grease	SHELL Alvania Grease EP (LF) 2	Retinax A
Engine oil	See operating instructions for the engine Shell Remula Super-FE 10 W 40 has been filled at the factory.						
Hydraulic oils	See (see section 1.1) Shell Tellus Oil 46 has been factory-filled.						
Gear oil 90	BP Multi EP SAE 90	ESSO GP 90	Total EP 90	MOBIL GX 90	Tranself EP 90	SHELL Spirax G 80 W - 90	
Gear oil 220	BP Energol GR-XP 220	ESSO Spartan EP 220	Total Carter EP 220	MOBIL Mobilgear 630 Mobil-gear SHC 220	Chevron NL Gear Compound 220	SHELL Omala 220	Optimol Optigear 220
	Optimol Optigear 220 has been factory-filled.						
Planetary gear Travel drive						Shell Transaxle SAE 75W-90 *	Optimol Optigear 220 **
	Optimol Optigear 220 has been factory-filled.						
Dist. water							
Diesel fuel							
Brake oil, brake fluid	BP Blue original Brake fluid	ATE disk brake fluid	Total HB F 4	ELF			
Cooling liquid	Cooling liquid (anti-freeze and corrosion protection) AGIP Antifreeze Spezial 956.99.58.15						

* Synthetic oil

** Mineral oil

1.1 Hydraulic oils

Preferred hydraulic oils:

a) Synthetic hydraulic liquids based on ester, HEES

Manufacturer	ISO viscosity class VG 46
Shell	Naturelle HF-E46
Panolin	HLP SYNTH 46
Esso	HE 46
Total Fina Elf	Total Biohydran SE 46

b) Mineral oil pressure fluids

Manufacturer	ISO viscosity class VG 46
Shell	Tellus Oil 46
Total Fina Elf	Total Azolla ZS 46

- m When switching from mineral oil pressure fluids to biodegradable pressure fluids, please contact our factory advisors!
- A Use only clean containers (inside and outside) for pouring oil or fuel in.

1.2 Filling volumes

	Operating substance	Volume	
Fuel tank	Diesel fuel	280	litres
Hydraulic oil reservoir	Hydraulic oils	175	litres
Pump distribution gear	Gear oil 90	4.5	litres
Planetary gear Travel drive **	see the section "Lubricants and operating substances"	2.8	litres
Drive axle (differential)***	Gear oil 90	18.0	litres
Conveyor gear transmission (each side)	Gear oil 220	1.5	litres
Central lubrication system (option)	Grease		
Batteries	Distilled water		

** Only on planer-finishers with wheel drive (direct drive)

*** Only on planer-finishers with wheel drive (manual gearbox)

Engine type Deutz TCD 2013 L06 2V

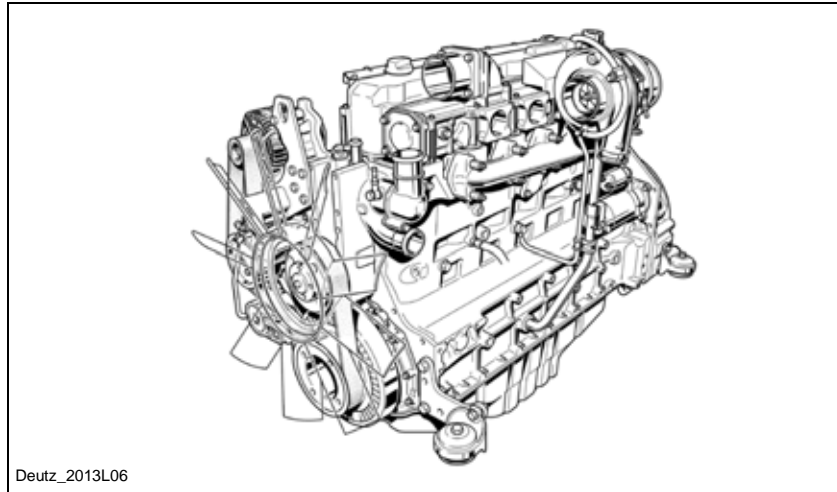

	Operating substance	Volume
Diesel engine (with oil filter change)	Engine oil 10W40	20,0 litres
Cooling system of the engine	Coolant	20,0 litres

Engine type Deutz TCD 2013 L04 2V

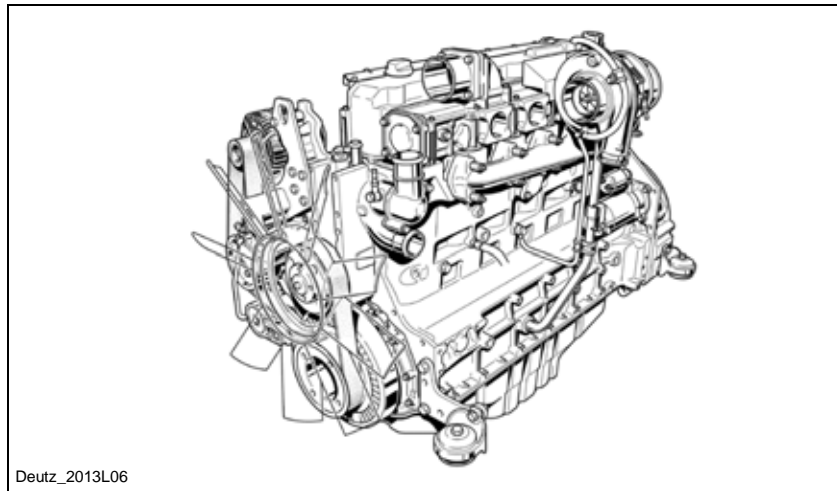

	Operating substance	Volume
Diesel engine (with oil filter change)	Engine oil 10W40	15,0 litres
Cooling system	Coolant	20,0 litres

Engine type Deutz TCD 2012 L06 2V

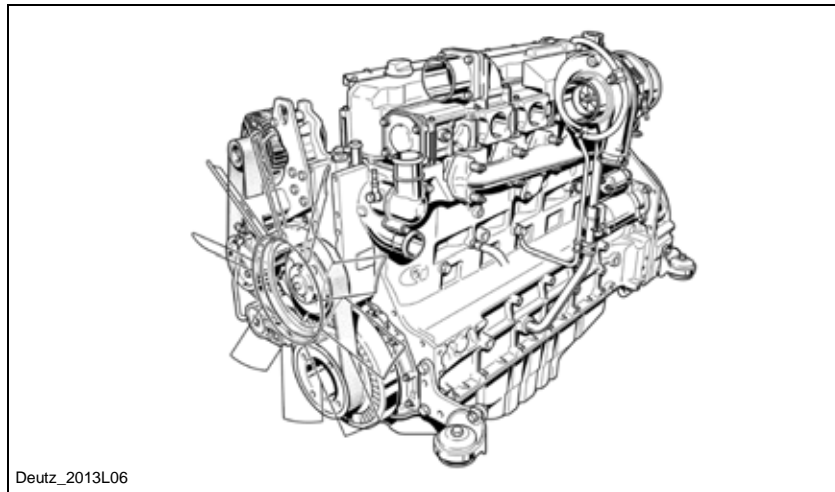

	Operating substance	Volume
Diesel engine (with oil filter change)	Engine oil 10W40	21,5 liters
Cooling system of the engine	Coolant	20,0 liters

Engine type Cummins QSB 6.7 C190, C205, C220

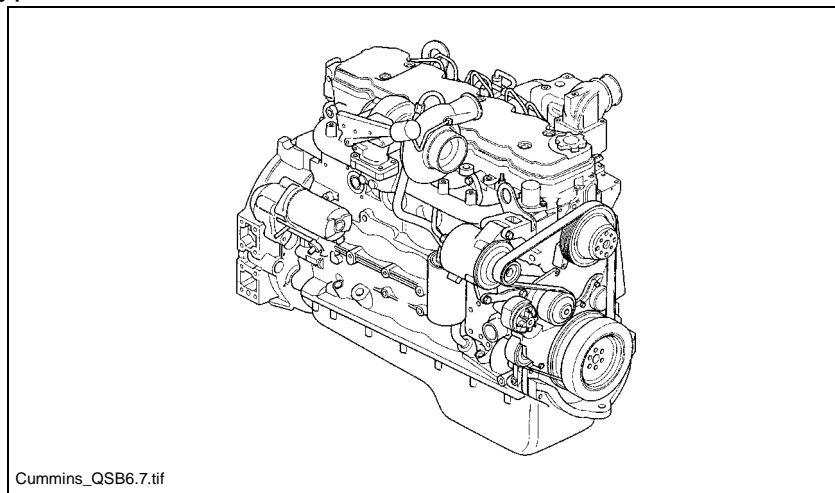

	Operating substance	Volume
Diesel engine (with oil filter change)	Engine oil 10W40	16,5 liters
Cooling system	Coolant	20,0 liters

Auger type I

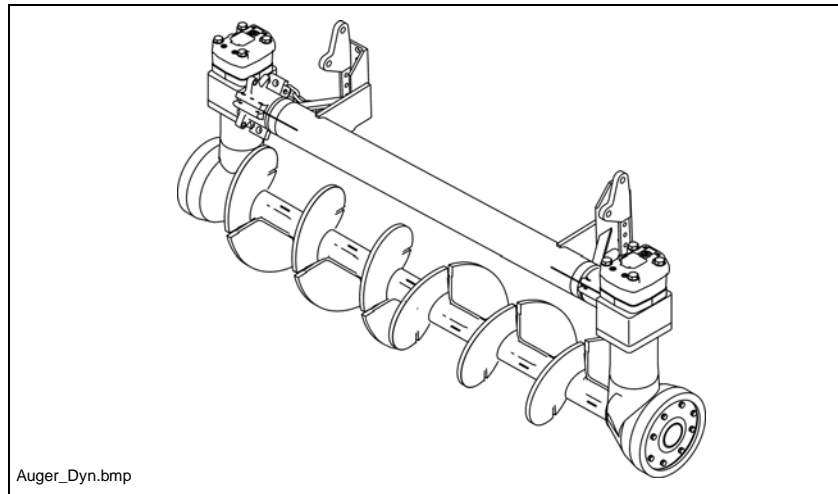

	Operating substance	Volume
Auger bevel gear (each side)	Gear oil 90	0.6 litres

Auger type II

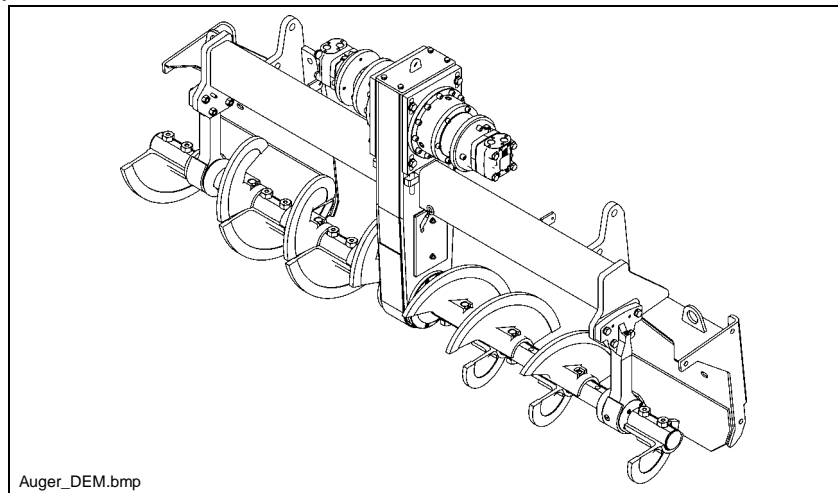

	Operating substance	Volume
Planetary gear Augers (each side)	Gear oil 90	0.5 litres
Auger box	Gear oil 460	2.5 litres
Outer auger bearing (per bearing)**	Hot bearing grease	115 grammes

** for new installation

2 Notes on changing over from mineral oil to synthetic oil / synthetic oil to mineral oil

2.1 Track planetary gear

m Never mix synthetic oils with mineral oils!

- Always drain used oil completely.

A The oil should be changed when at operating temperature.

- Flush out assembly with the new grade of oil to be used.
 - Operate track for 10 minutes for flushing purposes.
- Top up correct grade of oil in accordance with the relevant maintenance instructions.



TRAINING/EDUCATION

We offer our Customers various training programmes on DYNAPAC equipment in our specialised training centre in our factory. We hold training sessions also for special arrangements in addition to courses and programs held on fixed dates

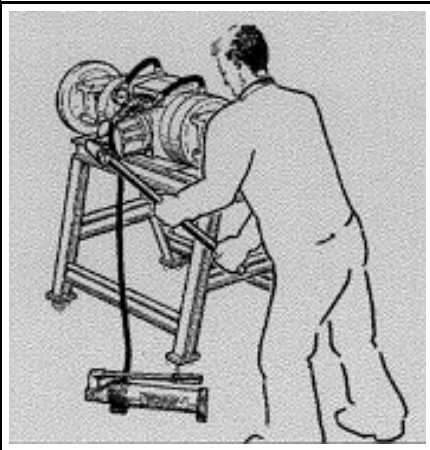
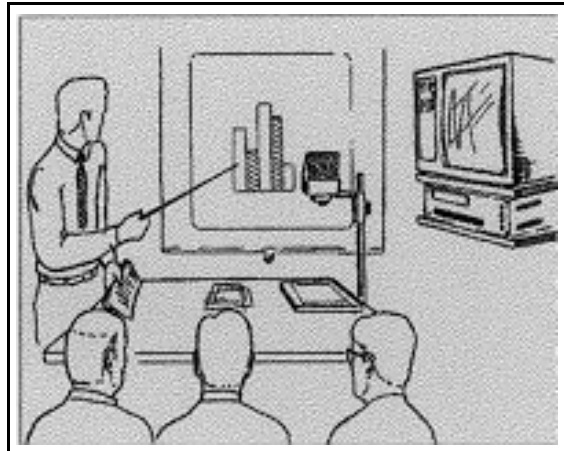

SERVICE

In case of operational failures and questions related to parts, please, contact one of our authorised service representations. Our skilled specialists will arrange for the fast and professional repair.

OPERATING ADVICE

Anytime when our dealers cannot help you, please, feel free to contact us directly. The team of our "Technical Advisors" is at your disposal.

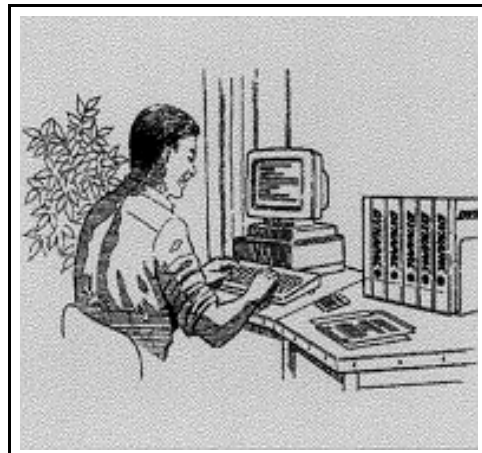

DYNAPAC

Part of the Atlas Copco Group

Don't hesitate to contact
your local dealer for:

service

spare parts

documentation

accessories

and

information

about the complete

Dynapac

paving and planing

range

