

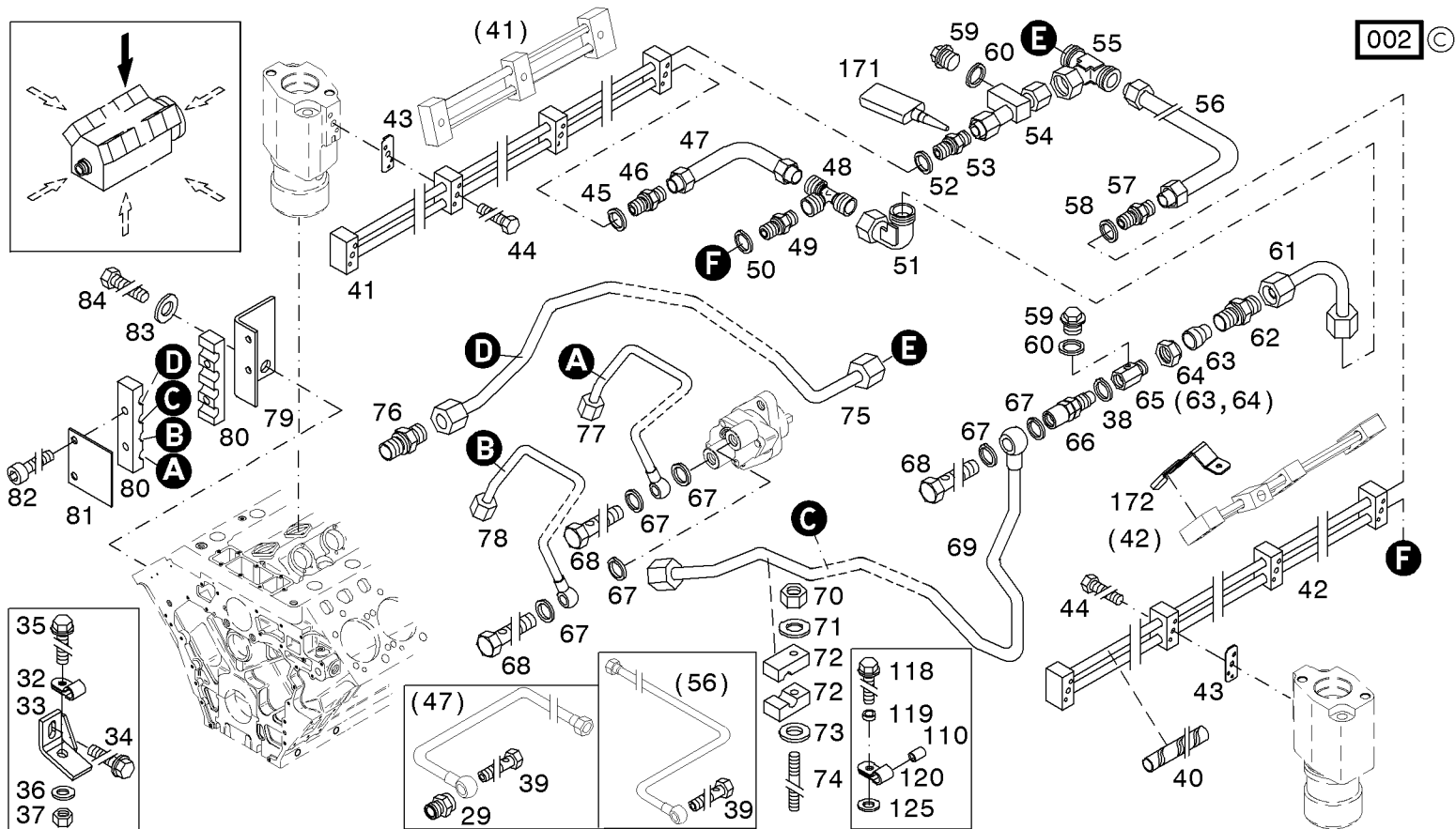

Kraftstoffleitung
Fuel line
Conduite à combustible
Tubería de combustible

Referenznr.:

0165-**(21)**-0510 2501





Kraftstoffleitung
Fuel line
Conduite à combustible
Tuberia de combustible

Referenznr.:

0165-**21**- 0510 2502

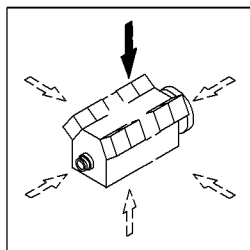

003 ©

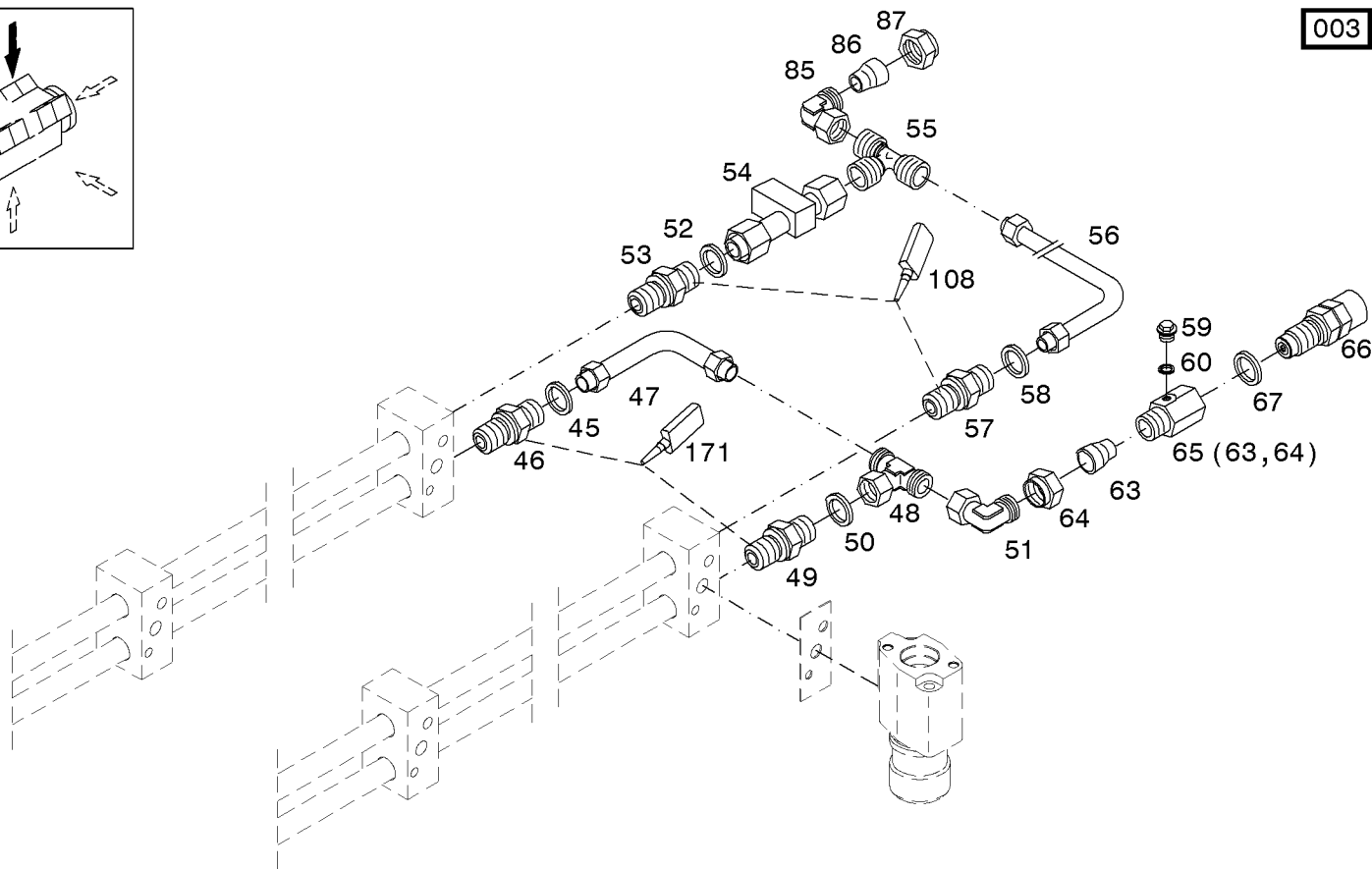



Einspritzleitung
High pressure pipe
Tuyauterie à haute pression
Tubería de inyección

Referenznr.:

0165-**(21)**-0510 2503

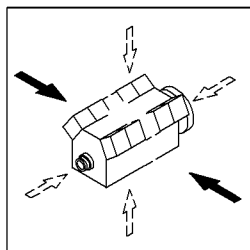

002 ©

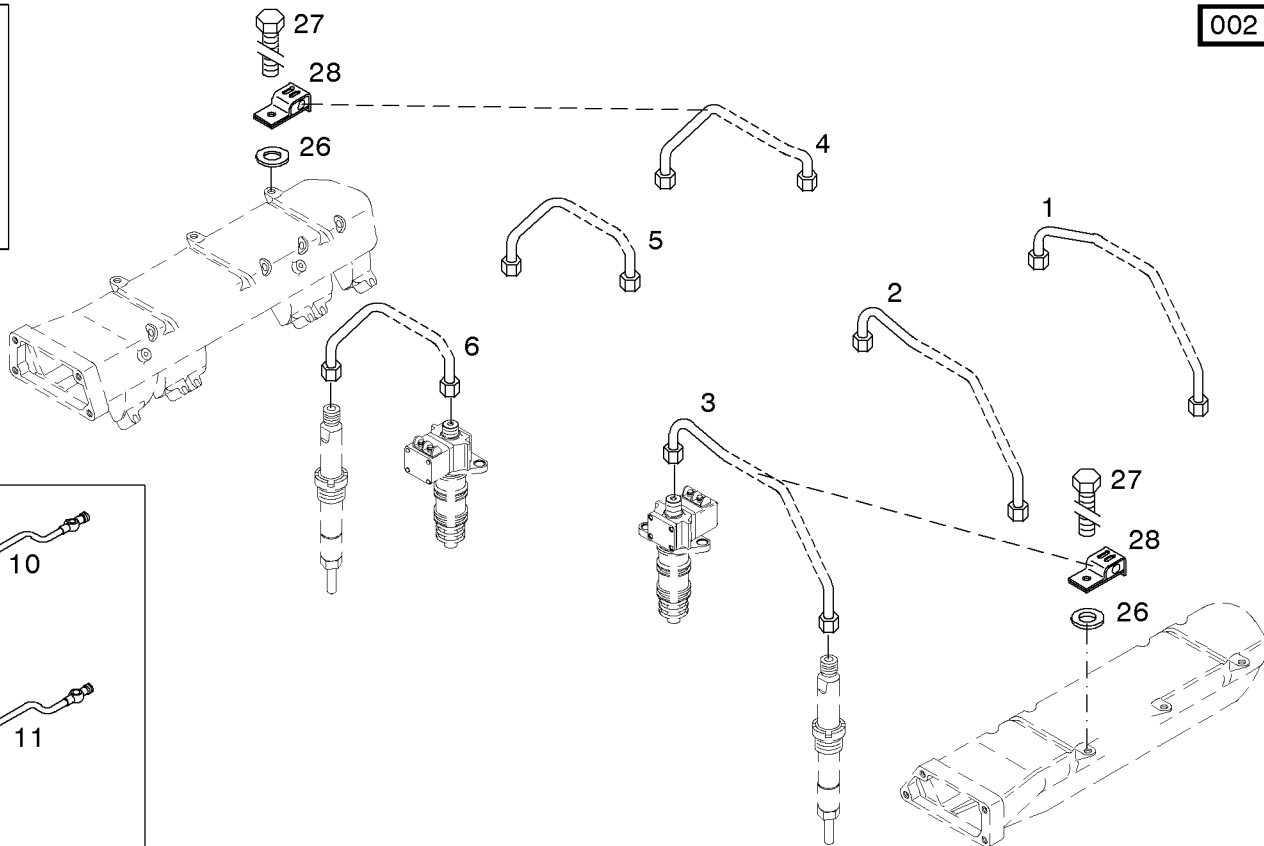
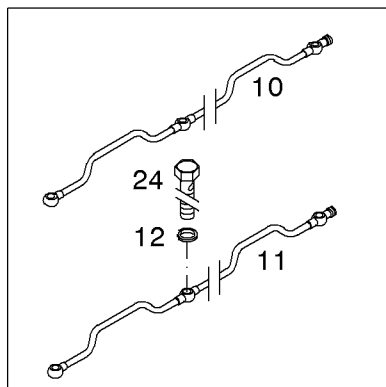



Einspritzleitung
High pressure pipe
Tuyauterie à haute pression
Tuberia de inyección

Referenznr.:

0165-21-0510 2504

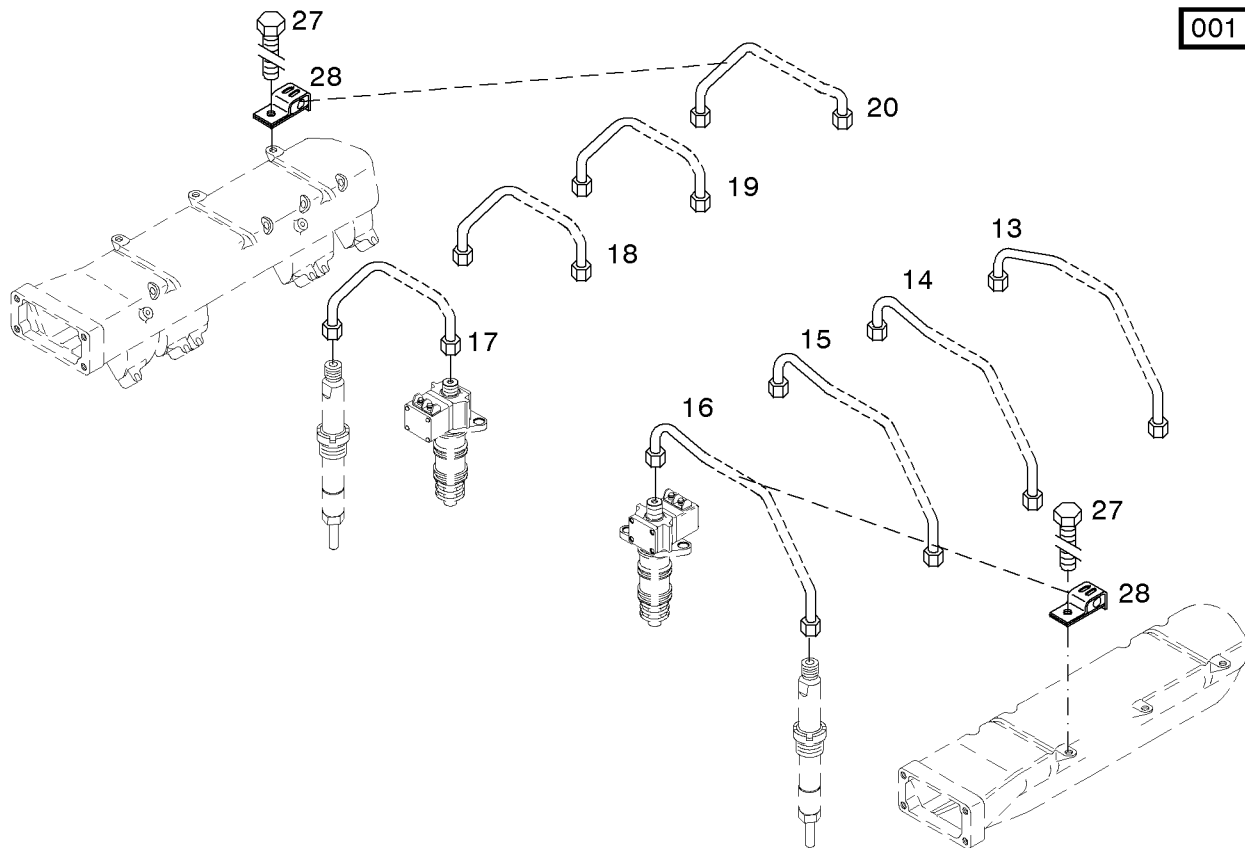
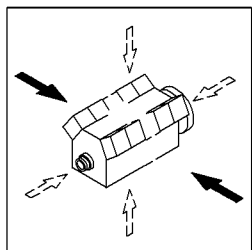



Einspritzleitung
High pressure pipe
Tuyauterie à haute pression
Tuberia de inyección

Referenznr.:

0165-**(21)**-0510 3554

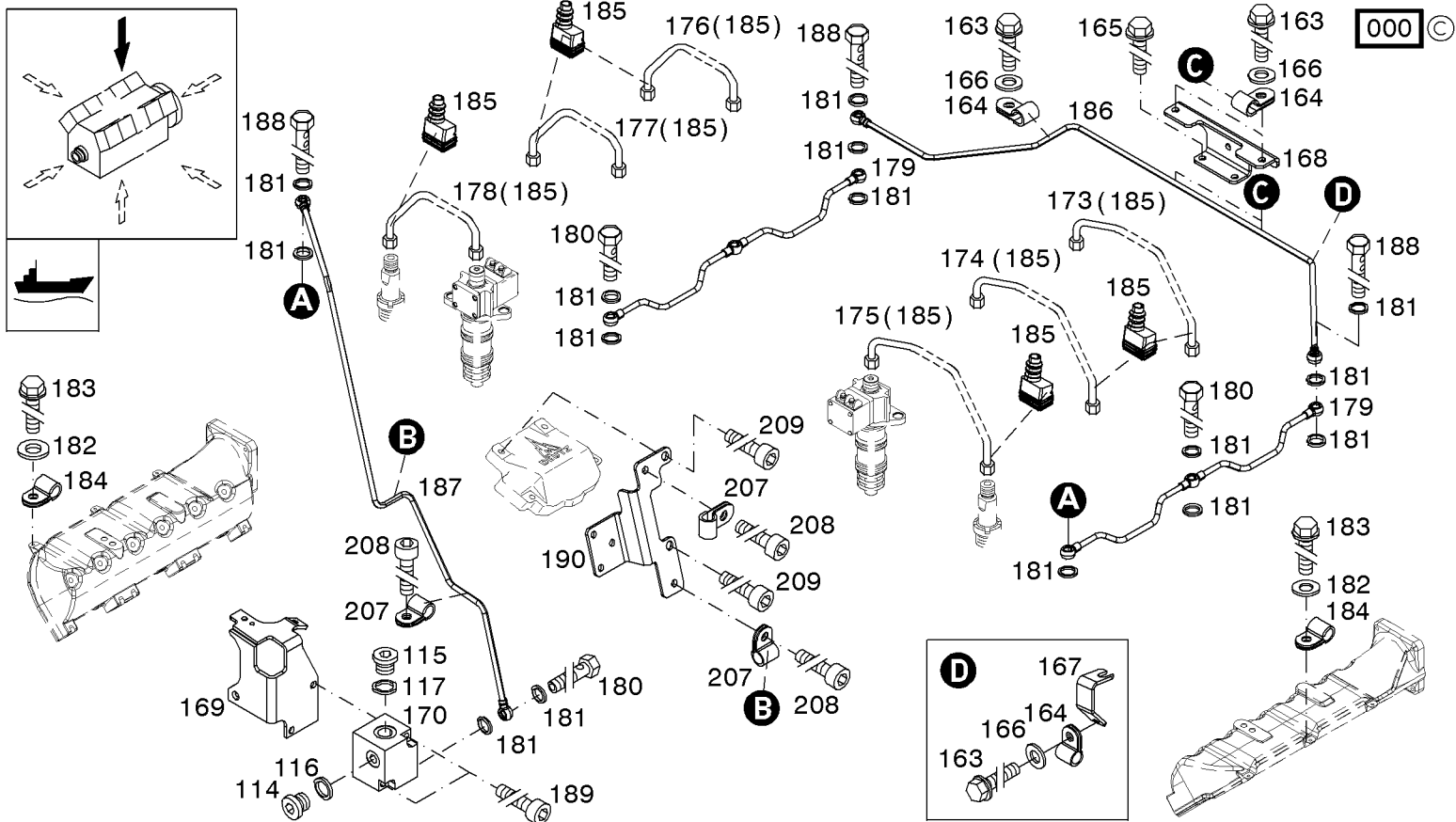



Einspritzleitung
High pressure pipe
Tuyauterie à haute pression
Tuberia de inyección

Referenznr.:

0165-**21**- 0510 3555

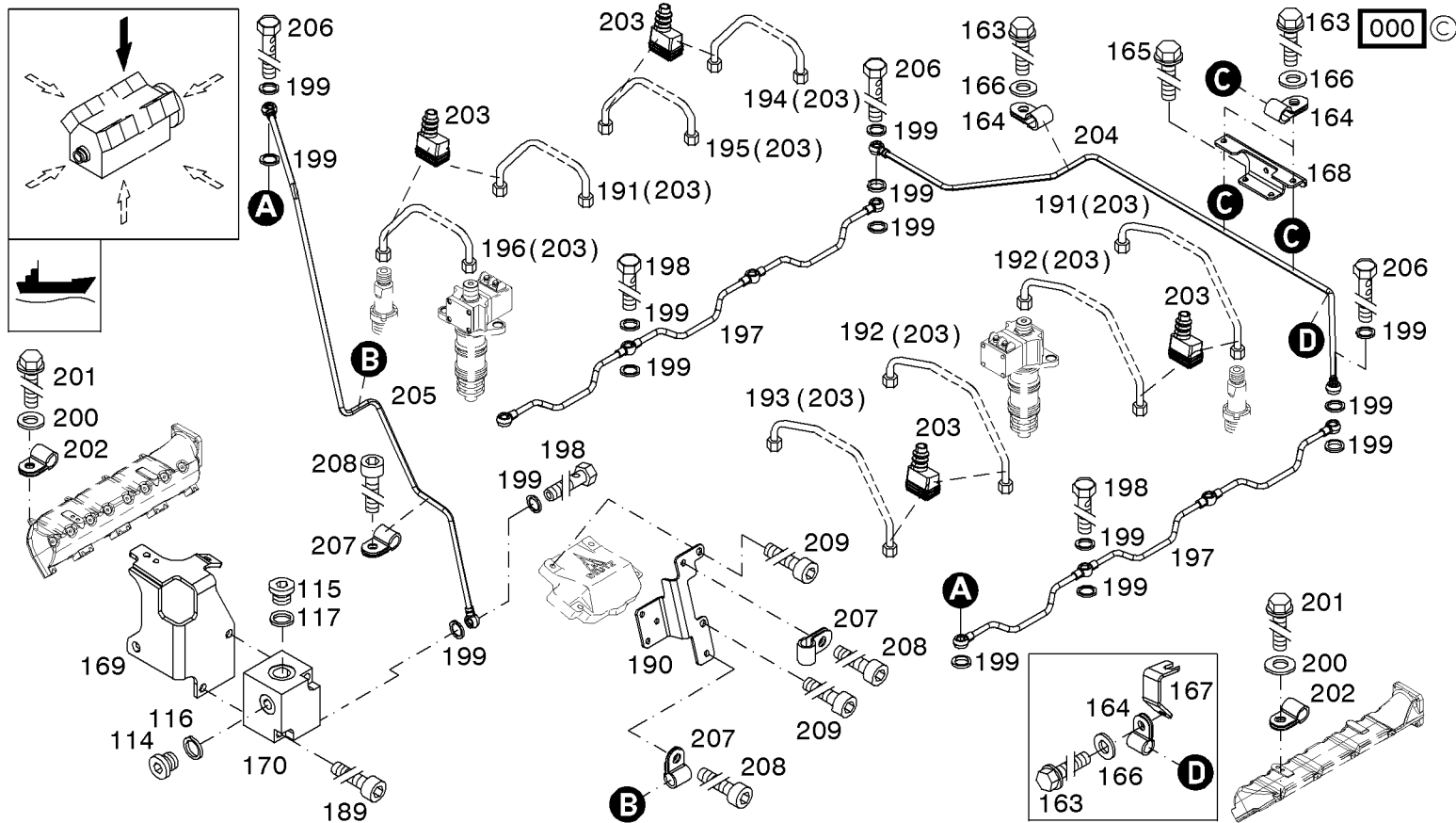



Kraftstoffleitung
Fuel line
Conduite à combustible
Tuberia de combustible

Referenznr.:

0165-**(21)**-0510 3556

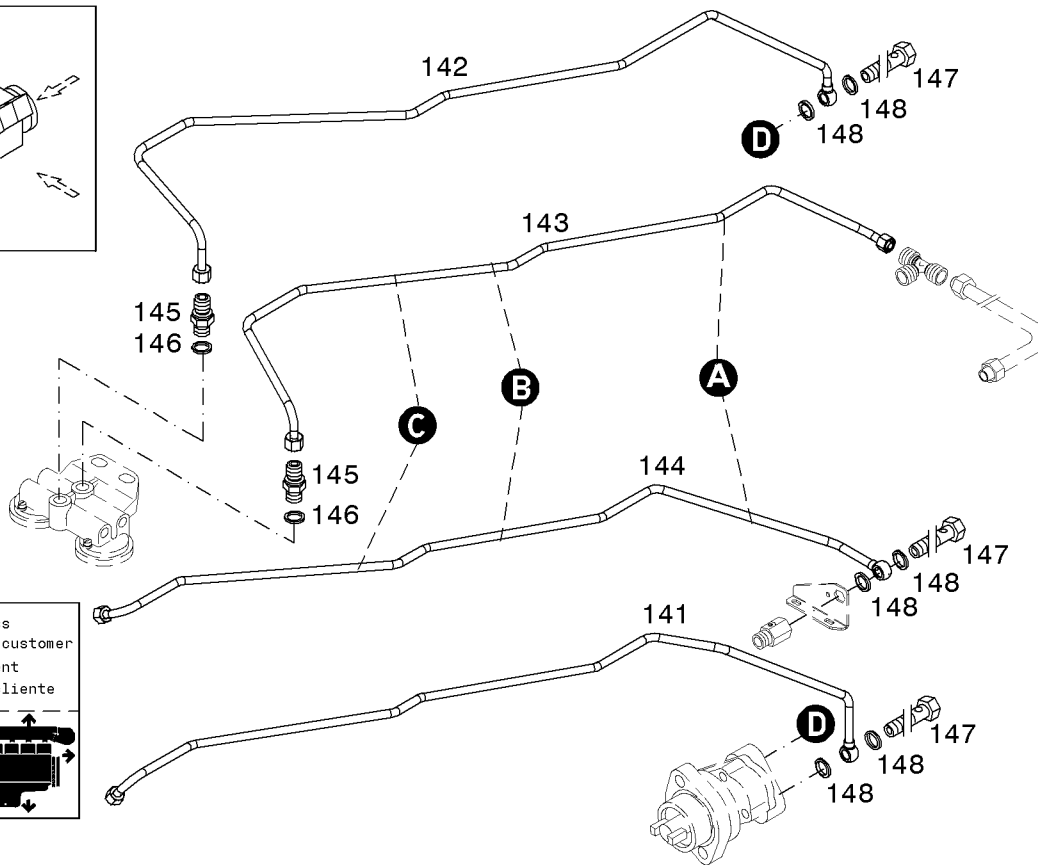
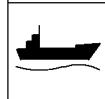
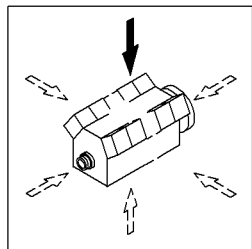

Kundenanschluss
Connection by customer
Connexion client
Conexion per cliente

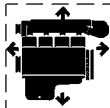

000 ©

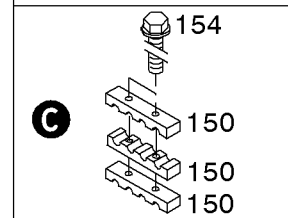
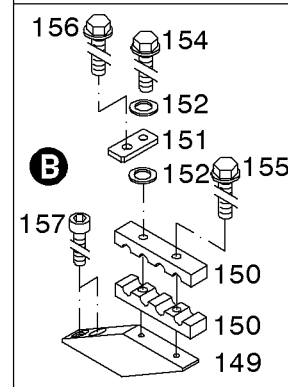
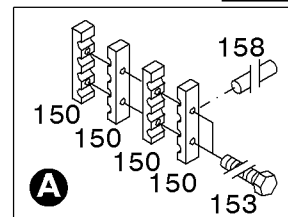



Kraftstoffleitung
Fuel line
Conduite à combustible
Tubería de combustible

Referenznr.:

0165-**21**- 0510 3557

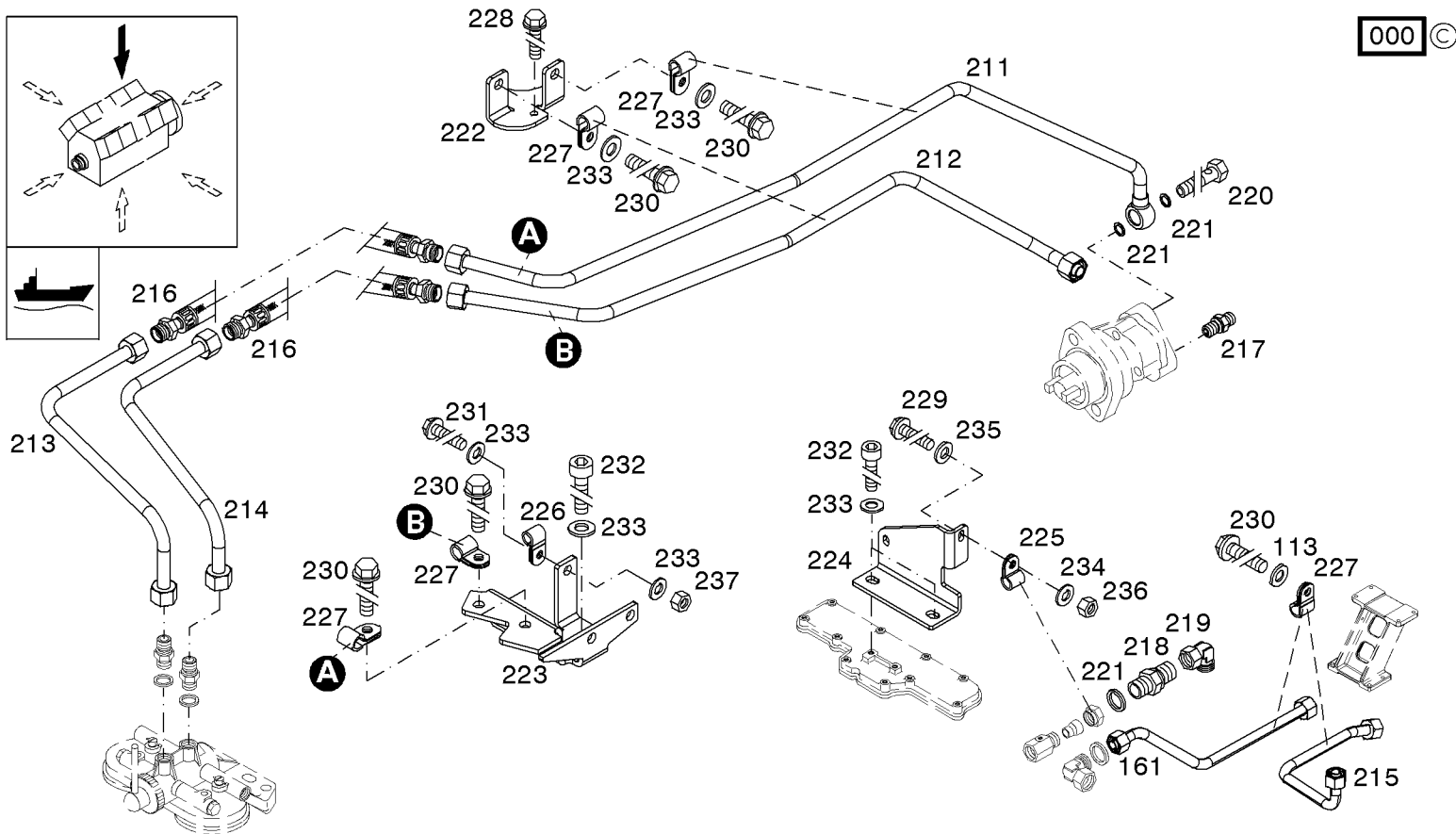
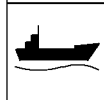
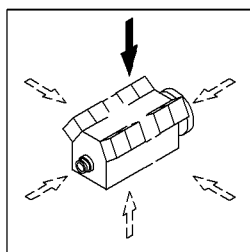

000 ©