

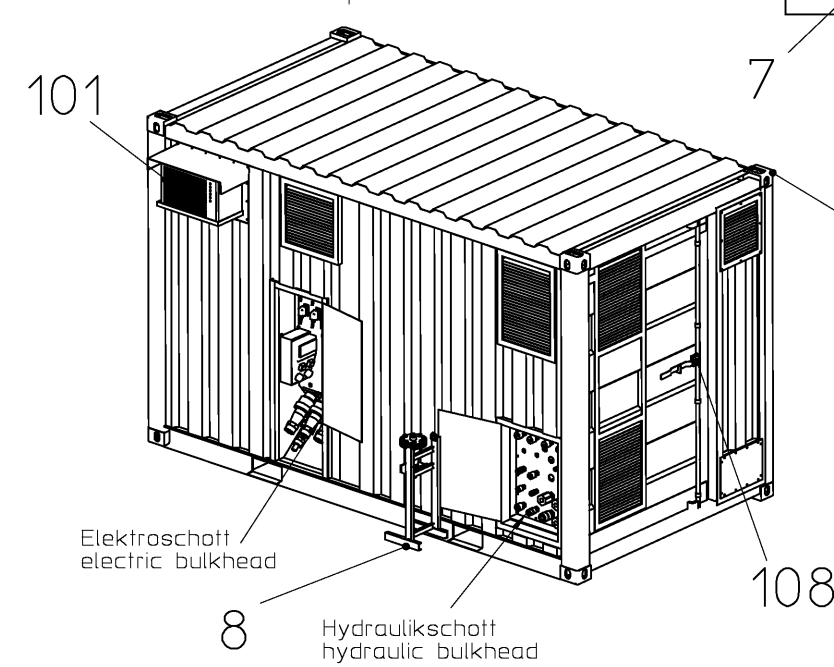

Allg. Ansicht 2
1:60

Allg. Ansicht 1
1:60

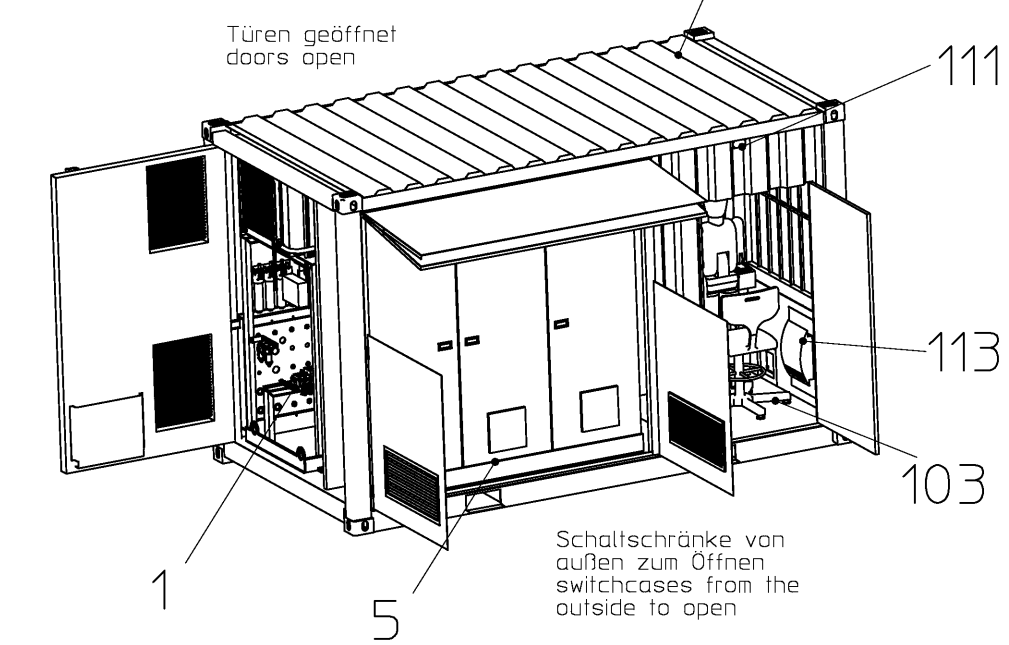
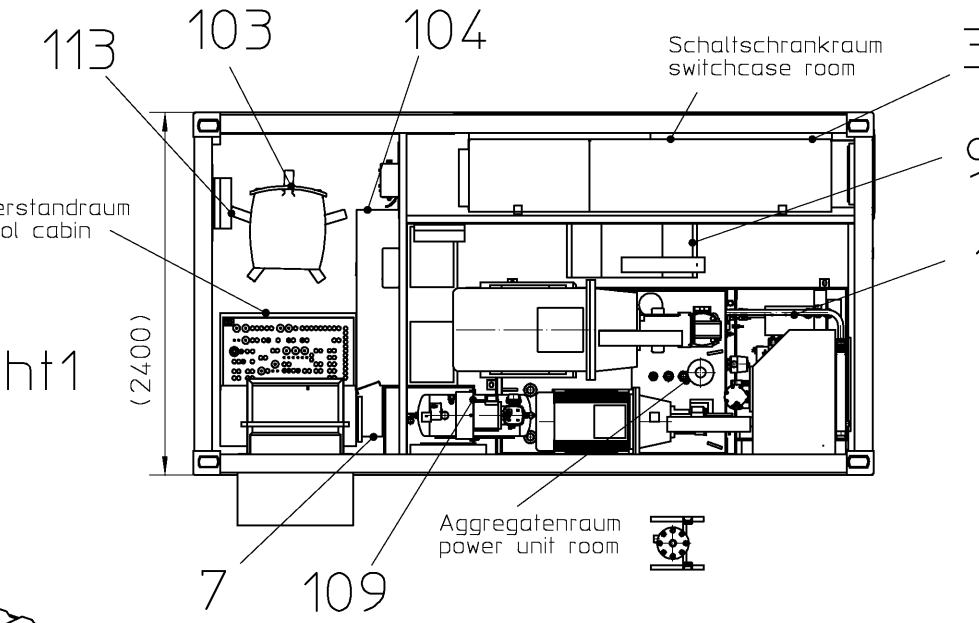

Zeichnung Schottbelegung Übersicht
bulkhead layout drawing overview
5557-004-000-00

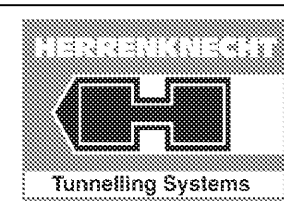
Pos.8	Stand-Alone Einheit	Art.Nr. 30253700
Pos.106	Werkzeugsatz-Montagesatz	Art.Nr. 22500020
Pos.300	PT Betriebscontainer	Art.Nr. 40348389

Revision	Change	Date	Drawn	Date	Released
The reproduction, distribution and utilization of this document as well as the communication of its contents to others without express authorization is prohibited. Offenders will be held liable for the payment of damages. All rights reserved in the event of the grant of a patent, utility model or design. ISO 16016					
Geometrical product specification (GPS) EN ISO 1101:2013			Edges of undefined shape ISO 13715:2000		
Surface specifications according to EN ISO 1302:1992			Drawing type assembly		Project M-2308C
 www.herrenknecht.com			Name OPERATION CONTAINER BETRIEBSCONTAINER C20-T000-P31-I2-F3202-B1-M10-0		
			Drawing number 5557-004-000-00		Sheet 1/1
drawn	16.03.2018	Wagner Lukas		Scale 1:50	Material no. 40344082
released	16.03.2018	Steiner Thomas		Material	Weight 9000 kg
				Projection	

Baukastenstückliste modular BOM



Projekt M-02308
Material 40344082
Bezeichnung 1 BETRIEBSCONTAINER
Zchnng.Nr/ver 5557-004-000-00 / -
Gewicht 9.000 KG
Werk 1000

project M-02308
material 40344082
designation 1 OPERATION CONTAINER
draw.No/ver 5557-004-000-00 / -
weight 9.000 KG
plant 1000

Pos.	Typ type	Material	Menge/Einheit qty/unit	Bezeichnung 1 / Bezeichnung 2	designation 1 / designation 2	Zchnng.Nr/ver/Bpf draw.No/ver	Gewicht weight
1	L	30150636	1,000 ST	HYDRAULIKAGGREGAT	HYDRAULIC POWER UNIT	2900-04-002-00/M	2.800,00 KG
3	L	30172371	1,000 ST	VERKLEIDUNGSBLECHE	COATING SHEETS	2900-04-000-10/C	13,00 KG
4	L	30170998	1,000 ST	AUFKLEBERSATZ	LABEL SET	2900-04-000-30/F	0,30 KG
5	Z	30172186	1,000 ST	SOCKEL	BASE		130,00 KG
6	Z	30158678	1,000 ST	WINTERPAKET	WINTER PACKAGE	2900-04-000-20/A	10,00 KG
7	L	30186751	1,000 ST	SIEBDRUCKPLATTE	SCREEN PRESSURE PLATE		7,20 KG
8	Z	30253700	1,000 ST	STAND-ALONE EINHEIT	STAND-ALONE UNIT		70,00 KG
9	L	40037248	1,000 ST	CONTAINER ZUSAMMENBAU	CONTAINER ASSEMBLY	4234-04-000-10/B	6.000,00 KG
10	L	30251946	1,000 ST	HALTER	RETAINER		0,60 KG
11	Z	40302632	1,000 ST	KLIMAGERÄT	AIR CONDITIONER	2666-04-000-40/-	80,00 KG
102	L	29350526	4,000 ST	GUMMIPUFFER	RUBBER BUFFER		0,10 KG
103	L	22530032	1,000 ST	ARBEITSDREHSTUHL	WORK SWIVEL CHAIR		8,00 KG
104	L	29908308	1,000 ST	WERKZEUGSCHRANK	TOOL CABINET		0,00 KG
105	L	30144497	1,000 ST	HALTERUNG	FIXING DEVICE	2606-06-030-20/C	14,00 KG
106	L	22500020	1,000 ST	WERKZEUGSATZ	TOOL SET		0,00 KG
107	L	29916586	1,000 ST	PROFILZYLINDER	PROFILE CYLINDER		0,24 KG
108	L	29904640	1,000 ST	VORHÄNGESCHLOSS	PADLOCK		0,15 KG
109	L	30138002	1,000 ST	KOMPRESSOR	COMPRESSOR		59,00 KG
110	L	29700843	1,000 ST	ANALYSENTEST	ANALYSIS TEST		50,00 G
111	L	26912579	1,000 ST	GEHÄUSE ELEKTRIK	HOUSING ELECTRIC		0,14 KG
112	L	22720080	1,000 ST	ERSTE-HILFE-KOFFER	FIRST-AID CASE		11,20 KG
113	Z	40322183	1,000 ST	HEIZUNG	HEATER		5,35 KG
114	L	40300689	1,000 ST	TESTBOX	TEST BOX		6,20 KG
116	L	26401232	1,000 ST	EE VERMESSUNGSSYSTEM	EE MEASUREMENT SYSTEM		8,43 KG
300	L	40348389	1,000 ST	PT BETRIEBSCONTAINER	PT OPERATION CONTAINER		1.628,21 KG

* Z = Infoteil
* Z = reference part