

Allg. Ansicht 2

Allg. Ansicht 1

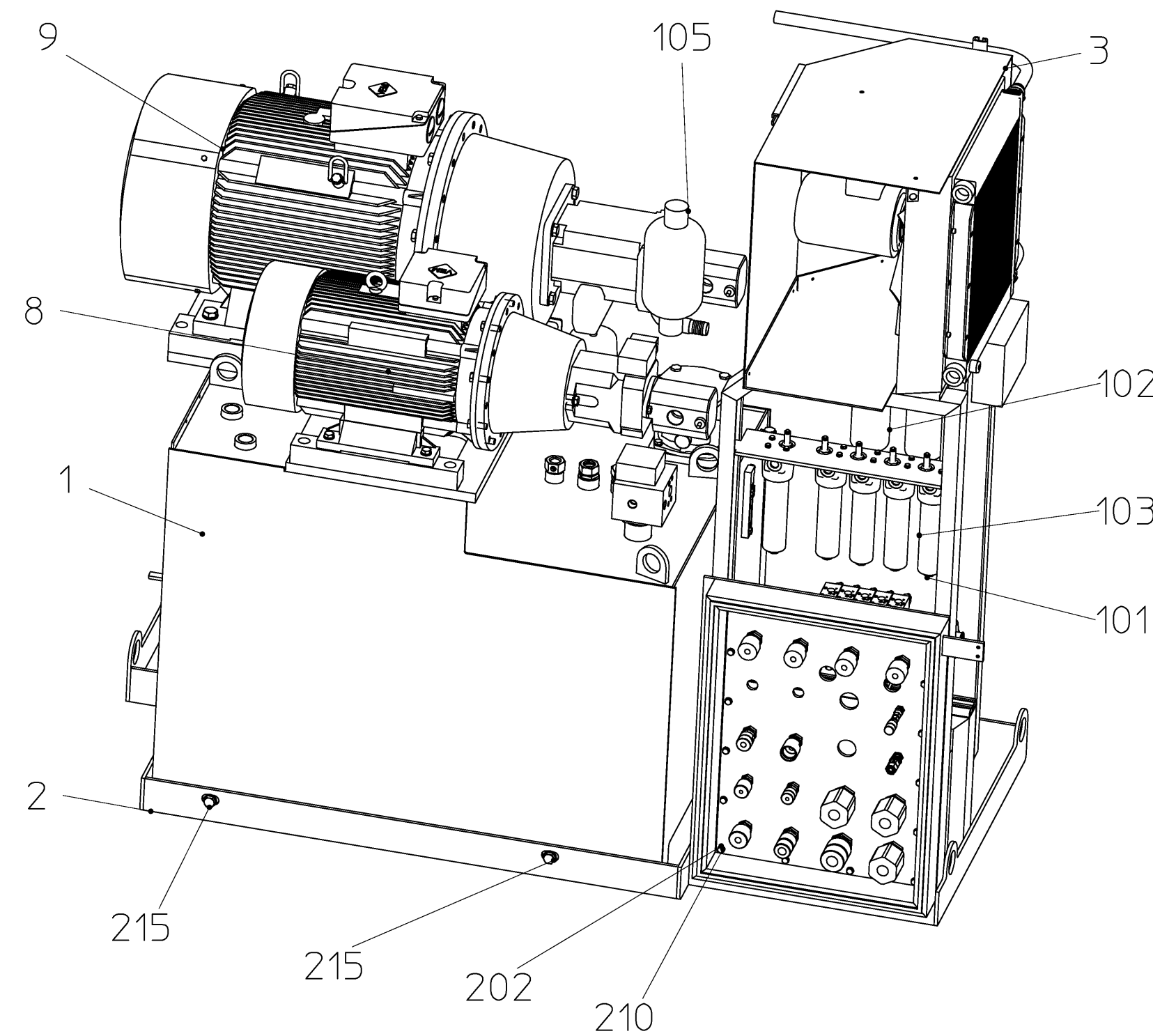
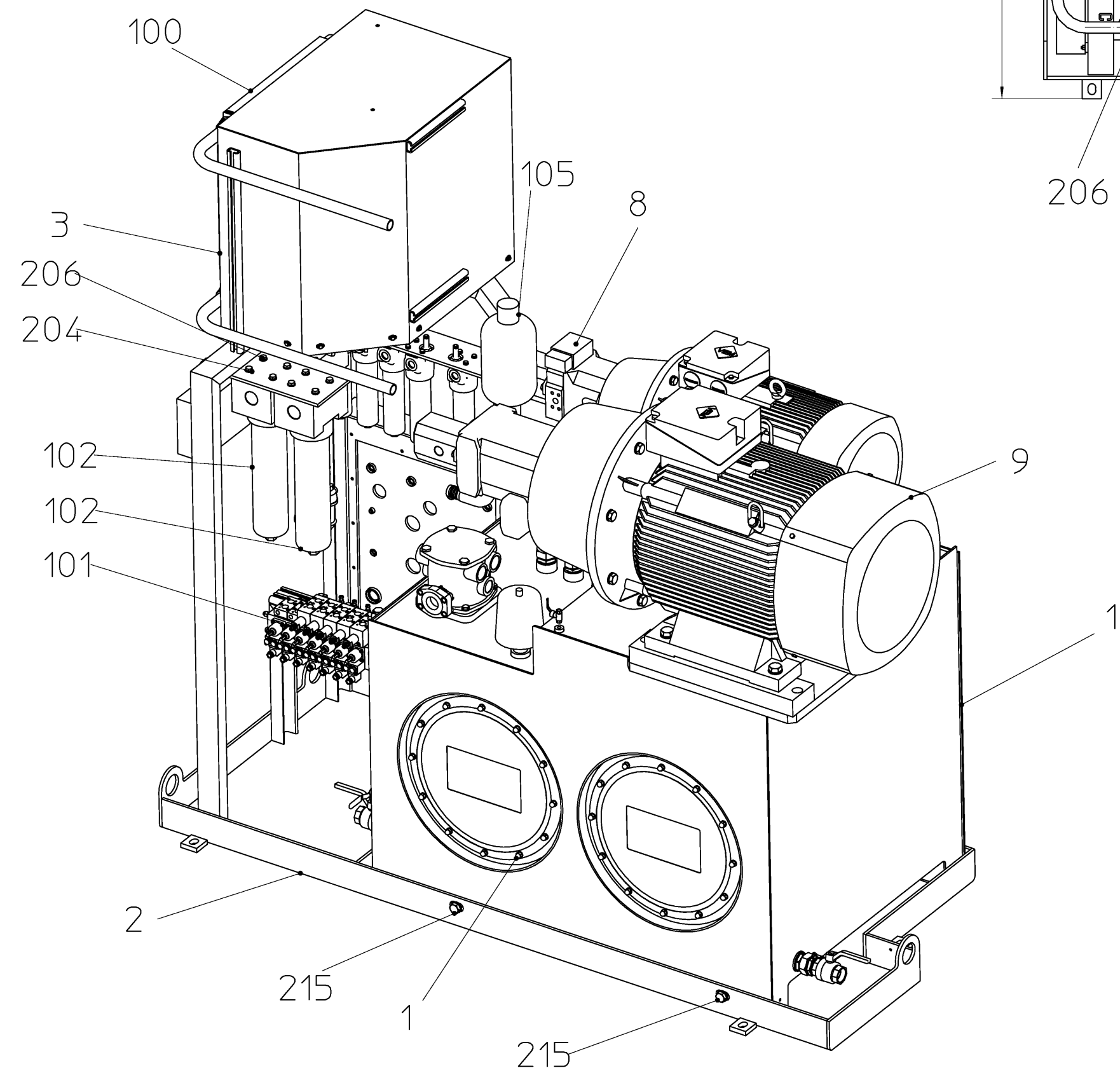

Wenn nicht anderweitig angegeben, sind metrische Schraffschrauben entsprechend den HERRENKNECHT-Anweisungen nach folgender Tabelle anzuziehen

Schrauben-Anzugsmomente in Nm
nach A-MBQ002, A-GW002, A-FS003 und A-MT005
Reibungskoeffizient $\mu_{ges.} = 0,12$

If not defined otherwise, metric screws have to be tightened in accordance with the prescriptions from HERRENKNECHT in the following table

Screw tightening torques in Nm
following A-MBQ002, A-GW002, A-FS003 and A-MT005
coefficient of friction $\mu_{tot} = 0,12$

	5.6	8.8	10.9	12.9
M6	4,3	9,9	14	16,5
M8	10,5	24	34	40
M10	21	44	64	75
M12	35	75	110	130
M20	165	360	520	600

The reproduction, distribution and utilization of this document as well as the communication of its contents to others without express authorization is prohibited. Offenders will be held liable for the payment of damages. All rights reserved in the event of the grant of a patent, utility model or design. ISO 15016

name HYDRAULIC POWER UNIT 1000L 37KW-110KW		drawing type assembly	scale 1:15	general tolerances	
drawing number 2900-04-002-00		sheet nr. 1/1	index M	projection M	surface specifications according to ISO 1302:1992
M	Pos.113 hinzu.	24.11.2017	WaL	24.11.2017	ManD
L	Pos.8 war 30166791	08.04.2016	EIJ	08.04.2016	ManD
K	Pos.111 war Menge 1	25.01.2016	EIJ	25.01.2016	ManD
Index	Änderung	Datum	Bearb.	Datum	Gepr.

Weitergabe sowie Vervielfältigung dieses Dokuments, Verwertung und Mitteilung seines Inhalts sind verboten, soweit nicht ausdrücklich gestattet. Zuwiderhandlungen verpflichten zu Schadenersatz. Alle Rechte für den Fall der Patent-, Gebrauchsmuster- oder Geschmacksmuster-Eintragung vorbehalten. ISO 15016

HERRENKNECHT AG Schlehenweg 2 D-77963 Schwanau Tel: 07824/392-0 Fax: 07824/3403 www.herrenknecht.de	HERRENKNECHT Tunnelvortriebstechnik	Zusammenstellung M-1600C C20-01	Projekt M-1600C	Maschinentyp C20-01
Benennung HYDRAULIKAGGREGAT 1000L 37KW-110KW		Zeichnungsnummer 2900-04-002-00	Blatt Nr. 1/1	Index M
Bearbeitet 31.08.2009 Zetting David	Freimittleranzahl	Oberflächen- angabe nach ISO 1302:1992	Malsstab 1:15	Artikelnummer 30150636
Geprüft 01.09.2010 Steiner Thomas			Werkstoff	Gewicht/kg 2800
				Format A1

Baukastenstückliste modular BOM



Projekt M-02308
Material [30150636](#)
Bezeichnung 1 HYDRAULIKAGGREGAT
Zchnng.Nr/ver 2900-04-002-00 / M
Gewicht 2.800 KG
Werk 1000

project M-02308
material [30150636](#)
designation 1 HYDRAULIC POWER UNIT
draw.No/ver 2900-04-002-00 / M
weight 2.800 KG
plant 1000

Pos.	Typ type	Material	Menge/Einheit qty/unit	Bezeichnung 1 / Bezeichnung 2	designation 1 / designation 2	Zchnng.Nr/ver/BpF draw.No/ver	Gewicht weight
1	L	30150634	1,000 ST	ÖLBEHÄLTER	OIL TANK	2900-04-002-04/J	1.610,00 KG
2	Z	30149729	1,000 ST	ÖLWANNE	OIL PAN	2900-04-002-01/D	475,00 KG
3	Z	30171681	1,000 ST	BLECH	SHEET		34,00 KG
5	L	30186732	1,000 ST	HALTERUNG	FIXING DEVICE		0,30 KG
6	L	30173463	1,000 ST	WINKEL	ANGLE		0,05 KG
7	Z	30070228	1,000 ST	EINSCHRAUBADAPTER	SCREW-IN ADAPTER	809-30-049-03/-	0,37 KG
8	L	40153279	1,000 ST	MOTORPUMPENEINHEIT	MOTOR PUMP UNIT	2900-04-004-50/-	447,00 KG
9	L	40090028	1,000 ST	MOTORPUMPENEINHEIT BASIS	MOTOR PUMP UNIT BASIC	4481-004-004-00/-	960,00 KG
10	L	30174968	1,000 ST	HYDRAULIKSCHOTTBLECH	HYDRAULIC BULKHEAD PLATE		55,00 KG
11	L	30187237	1,000 ST	HALTER	RETAINER		0,84 KG
12	L	30187239	1,000 ST	HALTER	RETAINER		2,30 KG
13	L	30187240	2,000 ST	HALTER	RETAINER		0,35 KG
14	L	30187241	1,000 ST	HALTER	RETAINER		0,05 KG
15	L	30199405	2,000 ST	LEISTE	STRIP	2900-04-002-11/A	0,70 KG
16	Z	40146931	1,000 ST	HALTER	RETAINER	2901-004-002-31/-	0,80 KG
100	Z	40314330	1,000 ST	WÄRMETAUSCHER ÖL/LUFT	HEAT EXCHANGER OIL/AIR		58,00 KG
101	Z	27203718	1,000 ST	STEUERBLOCK	CONTROL BLOCK		40,70 KG
102	Z	27000572	2,000 ST	HOCHDRUCKFILTER	HIGH-PRESSURE FILTER		32,60 KG
103	Z	27001525	5,000 ST	HOCHDRUCKFILTER	HIGH-PRESSURE FILTER		6,65 KG
104	Z	27501059	1,000 ST	DURCHFLUSSMESSER	FLOWMETER		32,00 KG
105	Z	27901583	1,000 ST	BLASENSPEICHER	BLADDER ACCUMULATOR		11,50 KG
106	L	27403814	2,000 ST	EINSCHRAUBVERSCHRAUBUNG	MALE STUD CONNECTOR		0,27 KG
107	L	27900055	1,000 ST	WARTUNGSEINHEIT	MAINTENANCE UNIT		1,60 KG
108	Z	27000641	1,000 ST	BELÜFTUNGSFILTER	VENTILATION FILTER		0,60 KG
109	Z	26904229	1,000 ST	DICHTUNGSBAND	SEAL BELT		0,30 KG

* Z = Infoteil
* Z = reference part

Baukastenstückliste modular BOM

Projekt M-02308
 Material 30150636
 Bezeichnung 1 HYDRAULIKAGGREGAT
 designation 1 HYDRAULIC POWER UNIT

Pos.	Typ type	Material	Menge/Einheit qty/unit	Bezeichnung 1 / Bezeichnung 2	designation 1 / designation 2	Zchnng.Nr/ver/Bpf draw.No/ver	Gewicht weight
110	L	21000295	4,000 ST	STECKKUPPLUNG MUFFE	CONNECT COUPLING SOCKET		0,08 KG
111	L	21000299	2,000 ST	STECKKUPPLUNG STECKER	CONNECT COUPLING PLUG		0,08 KG
112	L	27904304	2,000 ST	HALTERAHMEN	RETAINING FRAME		0,28 KG
113	L	26912604	1,000 ST	GUMMITÜLLE	RUBBER GROMMET		0,00 KG
200	L	24000207	8,000 ST	SCHEIBE GVZ A5,3-140HV-DIN125	WASHER ZP A5,3-140HV-DIN125		0,44 G
201	L	24000209	19,000 ST	SCHEIBE GVZ A8,4-140HV-DIN125	WASHER ZP A8,4-140HV-DIN125		1,83 G
202	L	24000210	26,000 ST	SCHEIBE GVZ A10,5-140HV-DIN125	WASHER ZP A10,5-140HV-DIN125		10,00 G
204	L	24000211	8,000 ST	SCHEIBE GVZ A13-140HV-DIN125	WASHER ZP A13-140HV-DIN125		6,00 G
205	L	24007437	4,000 ST	SCHEIBE GVZ A21-140HV-DIN125	WASHER ZP A21-140HV-DIN125		17,20 G
206	L	24001792	8,000 ST	SECHSKANTSCHRAUBE GVZ M12X40-8.8-DIN933	HEX. HEAD SCREW ZP M12X40-8.8-DIN933		45,00 G
207	L	24001945	2,000 ST	SECHSKANTMUTTER GVZ M8-8-DIN934	HEX.NUT ZP M8-8-DIN934		5,20 G
208	L	24002692	6,000 ST	SECHSKANTSCHRAUBE GVZ M6X12-8.8-DIN933	HEX. HEAD SCREW ZP M6X12-8.8-DIN933		0,00 KG
209	L	24002694	15,000 ST	SECHSKANTSCHRAUBE GVZ M8X25-8.8-DIN933	HEX. HEAD SCREW ZP M8X25-8.8-DIN933		0,01 KG
210	L	24001796	16,000 ST	SECHSKANTSCHRAUBE GVZ M10X20-8.8-DIN933	HEX. HEAD SCREW ZP M10X20-8.8-DIN933		20,00 G
211	L	24002905	9,000 ST	SECHSKANTSCHRAUBE GVZ M10X35-8.8-DIN933	HEX. HEAD SCREW ZP M10X35-8.8-DIN933		0,03 KG
212	L	24003619	2,000 ST	SECHSKANTSCHRAUBE GVZ M8X30-8.8-DIN933	HEX. HEAD SCREW ZP M8X30-8.8-DIN933		0,02 KG
213	L	26907320	11,000 ST	GEWINDEPLÄTTCHEN	THREADED PLATELET		15,13 G
214	L	24004324	8,000 ST	SECHSKANTSCHRAUBE GVZ M5X12-8.8-DIN933	HEX. HEAD SCREW ZP M5X12-8.8-DIN933		0,00 KG
215	L	24007872	4,000 ST	SECHSKANTSCHRAUBE GVZ M20X40-8.8-DIN933	HEX. HEAD SCREW ZP M20X40-8.8-DIN933		0,16 KG
217	L	40019062	6,000 ST	SCHEIBE GVZ 6,4-ST-DIN7349	WASHER ZP 6,4-ST-DIN7349		4,60 G
219	L	26902130	4,000 ST	GEWINDEPLÄTTCHEN	THREADED PLATELET		9,72 G