

3D Ansicht1

Kompressor 50Hz
SA:21001424

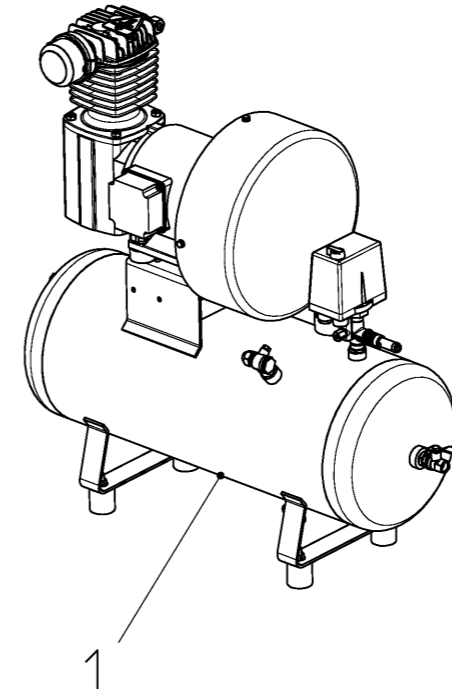

3D Ansicht2

Kompressor 60Hz
SA:21001217

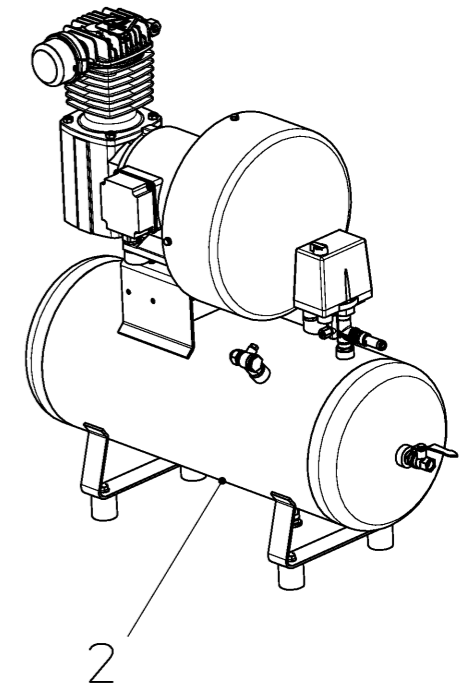

The reproduction, distribution and utilization of this document as well as the communication of its contents to others without express authorization is prohibited. Offenders will be held liable for the payment of damages. All rights reserved in the event of the grant of a patent, utility model or design. ISO 16016

name BASE COMPRESSOR KC390 400/460V 50/60HZ		drawing type assembly	scale 1:10	general tolerances	
drawing number 2584-04-002-10		part number 30138002	weight/kg 59		
sheet nr. 1/1	index D	projection 	surface specifications according to ISO 1302:1992		
D	Pos.3 in STL entfernt		22.08.2011	EIJ	22.08.2011 Loh
C	Pos.3 21001336 in Stüli ergänzt		29.03.2011	Loh	29.03.2011 Loh
B	Pos.1 war SA21000915		14.01.2011	ManD	24.01.2011 ST
Index	Änderung		Datum	Bearb.	Datum Gepr.

Diese Unterlage (Zeichnung) ist unser Eigentum. Jede Vervielfältigung, Verwertung oder Mitteilung an dritte Personen ist strafbar und wird gerichtlich verfolgt (Urhebergesetz, gegen unlauteren Wettbewerb, BGB). Alle Rechte aus §7 PG vorbehalten.

HERRENKNECHT AG
Schlehenweg 2
D-77963 Schwanau
Tel.: 07824/302-0
Fax: 07824/3403
www.herrenknecht.de



Zeichnung Zusammenstellung	Projekt M-1433C	Maschinentyp CONTAINER
Benennung BASIS KOMPRESSOR KC390 400/460V 50/60HZ		

	Datum	Name	Freimaßtoleranzen	Oberflächen- angabe nach DIN ISO 1302	Zeichnungsnummer 2584-04-002-10	Blatt Nr. 1/1	Index D		
Bearbeitet	10.12.2008	Farinacci			Maßstab 1:10	Artikelnummer 30138002	Werkstoff	Gewicht/kg 59	Format A3
Geprüft	10.12.2008	Steiner Thomas							

Baukastenstückliste modular BOM



Projekt M-02308
 Material [30138002](#)
 Bezeichnung 1 KOMPRESSOR
 Zchnng.Nr/ver 2584-04-002-10 / D
 Gewicht 59 KG
 Werk 1000

project M-02308
 material [30138002](#)
 designation 1 COMPRESSOR
 draw.No/ver 2584-04-002-10 / D
 weight 59 KG
 plant 1000

Pos.	Typ type	Material	Menge/Einheit qty/unit	Bezeichnung 1 / Bezeichnung 2	designation 1 / designation 2	Zchnng.Nr/ver/Bpf draw.No/ver	Gewicht weight
1	L	21001424	1,000 ST	KOMPRESSOR	COMPRESSOR		63,00 KG
2	L	21001217	1,000 ST	KOMPRESSOR	COMPRESSOR		59,00 KG

* Z = Infoteil
 * Z = reference part