

Wenn nicht anderweitig angegeben, sind metrische Schraubschrauben entsprechend den HERRENKNECHT-Anweisungen nach folgender Tabelle anzuziehen

**Schrauben-Anzugsmomente in Nm**  
nach A-MBQ002, A-GW002, A-FS003 und A-MT005  
Reibungskoeffizient  $\mu_{ges.} = 0,12$

If not defined otherwise, metric screws have to be tightened in accordance with the prescriptions from HERRENKNECHT in the following table

**Screw tightening torques in Nm**  
following A-MBQ002, A-GW002, A-FS003 and A-MT005  
coefficient of friction  $\mu_{tot.} = 0,12$

	5.6	8.8	10.9	12.9
M6	4,3	9,9	14	16,5

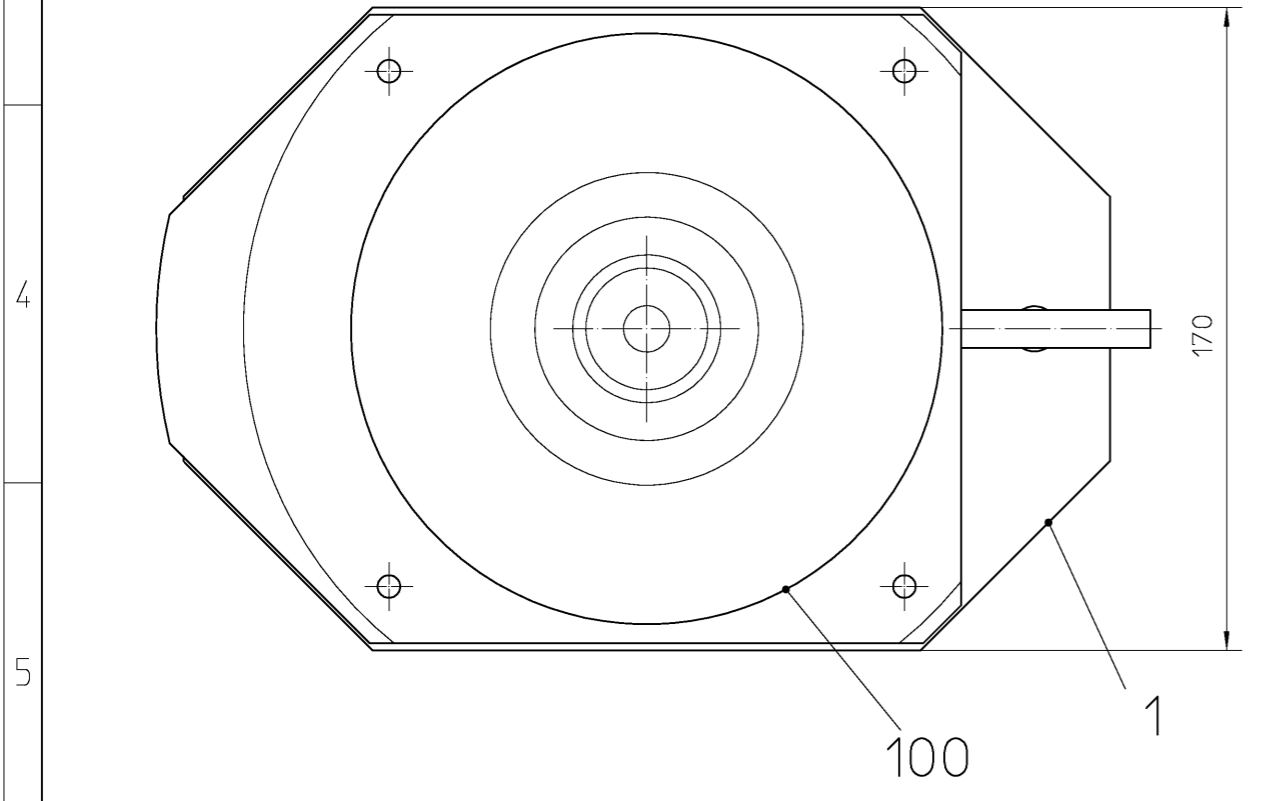

Pos.102	Art.Nr.: 40087627	Bez.1: KABEL	Kabellänge: 10M
Pos.103	Art.Nr.: 26907062	Bez.1: STECKER	

The reproduction, distribution and utilization of this document as well as the communication of its contents to others without express authorization is prohibited. Offenders will be held liable for the payment of damages. All rights reserved in the event of the grant of a patent, utility model or design. ISO 16016

name <b>WARNING LIGHT ASSEMBLY</b> NEXUS110/18		drawing type <b>assembly</b>	scale <b>1:2</b>	general tolerances	
drawing number <b>2900-04-000-40</b>		sheet nr. <b>1/1</b>	index <b>B</b>	part number <b>40165723</b>	weight/kg <b>2.2</b>
projection 		surface specifications according to ISO 1302:1992			
B	Pos.102 Abmessung geändert.	08.04.2016	WaL	08.04.2016	ManD
A	Abmessung Pos.102 geändert.	07.04.2016	WaL	08.04.2016	ManD
Index	Änderung	Datum	Bearb.	Datum	Gepr.

Weitergabe sowie Vervielfältigung dieses Dokuments, Verwertung und Mitteilung seines Inhalts sind verboten, soweit nicht ausdrücklich gestattet. Zuwiderhandlungen verpflichten zu Schadenersatz. Alle Rechte für den Fall der Patent-, Gebrauchsmuster- oder Geschmacksmuster-Eintragung vorbehalten. ISO 16016

HERRENKNECHT AG Schlehenweg 2 D-77963 Schwanau Tel.: 07824/302-0 Fax: 07824/3403 www.herrenknecht.de	 Tunnelvortriebstechnik	Zeichnung <b>Zusammenstellung</b>	Projekt <b>M-1600C</b>	Maschinentyp <b>C20-01</b>
		Benennung <b>WARNLEUCHTE BAUGRUPPE</b> NEXUS110/18		

Bearbeitet	07.04.2016	Wagner Lukas	Freimaßtoleranzen	Oberflächen- angabe nach ISO 1302:1992	Zeichnungsnummer <b>2900-04-000-40</b>	Blatt Nr. <b>1/1</b>	Index <b>B</b>
Geprüft	07.04.2016	Mannherz Daniel					

Projektion 	Maßstab <b>1:2</b>	Artikelnummer <b>40165723</b>	Werkstoff	Gewicht/kg <b>2.2</b>	Format <b>A3</b>
----------------	-----------------------	----------------------------------	-----------	--------------------------	---------------------

# Baukastenstückliste modular BOM



Projekt M-02308  
 Material 40165723  
 Bezeichnung 1 WARNLEUCHTE BAUGRUPPE  
 Zchnng.Nr/ver 2900-04-000-40 / B  
 Gewicht 2,200 KG  
 Werk 1000

project M-02308  
 material 40165723  
 designation 1 WARNING LIGHT ASSEMBLY  
 draw.No/ver 2900-04-000-40 / B  
 weight 2,200 KG  
 plant 1000

Pos.	Typ type	Material	Menge/Einheit qty/unit	Bezeichnung 1 / Bezeichnung 2	designation 1 / designation 2	Zchnng.Nr/ver/Bpf draw.No/ver	Gewicht weight
1	L	40165053	1,000 ST	MONTAGEBLECH	MOUNTING PANEL	809-01-001-79/B	0,30 KG
100	L	26908551	1,000 ST	WARNLEUCHTE+HUPE	WARNING LIGHT+HORN		1,20 KG
101	L	26913743	2,000 ST	PERMANENTMAGNET	PERMANENT MAGNET		37,50 G
102	R	40087627	10,000 M	KABEL	CABLE		128,00 G
103	L	26907062	1,000 ST	STECKER	MALE PLUG		0,04 KG
200	L	24001852	2,000 ST	SENKSCRAUBE GVZ M6X20-4.8-DIN963	COUNTERSUNK HEAD SCREW ZP M6X20-4.8-DIN963		0,00 KG
201	L	24001944	2,000 ST	SECHSKANTMUTTER GVZ M6-8-DIN934	HEX.NUT ZP M6-8-DIN934		2,50 G
202	L	24000208	2,000 ST	SCHEIBE GVZ A6,4-140HV-DIN125	WASHER ZP A6,4-140HV-DIN125		8,00 G

\* Z = Infoteil  
 \* Z = reference part