

21. Automatic Laser Cut-Out

The kick guard can be activated if wanted via the menu. It is active, as soon as a T appears in the status display. This means the laser is switched off automatically as a precautionary measure in the event of a jerky movement (bump). The T then begins to blink. The laser beam must then be switched on again by briefly pressing the On button and the positioning checked and corrected if necessary.

22. Monitoring of Self-Levelling

The self-levelling function corrects even the smallest deviation. At a deviation of approx. 0.01 % the laser beam and laser beam symbol begin to blink. Depending on the setting, blinking can start earlier at approx. 0.005 % or later at approx. 0.015 %.

23. Flicker Mode

Flickering makes the laser beam significantly easier to see in unfavourable light conditions.

24. Power Supply

220 V Operation

Connect the drifting laser to the power supply type NE-12/2A.

Note: The laser may not be connected directly to the battery of a running engine or to a charging device. Also make sure that the housing of the laser does not come into direct contact with the poles of the battery or with the body work of a motor vehicle.

In the case of welding work care must be taken to ensure that the current cannot flow through the laser:

Disconnect all cable connections to the laser!

12 V Operation

Connect the laser to a 12 V rechargeable battery or energy box type EB-12/24 (48.01) with the battery connector (47.00). Make sure that the red terminal is connected to the plus pole and the black terminal to the minus pole. Incorrect polarity will not damage the laser, but the laser will not work.

25. Setting the Inclination

The laser beam is set at a defined inclination with the arrow up / down buttons.

Note: The gradient/inclination is shown in %, not in degrees or gon.

The defined inclined directional beam refers to the automatic levelling of the laser.

26. Calculating the Percentage

If the percentage value that is to be set is not known, it can be calculated as follows:

Example: Height difference between 2 points = 0.2 m
Length between 2 points = 50 m

$$\frac{\text{Height difference} \times 100}{\text{Length}} = \frac{0.2 \times 100}{50} = 0.4 \%$$

Convert % to ‰ - move the decimal point one place to the right.

Convert ‰ to % - move the decimal point one place to the left.

27. Setting the Direction

When the inclination has been set, align the laser roughly on the target point with the mounting device and then finely with the buttons.

The direction can also be set with the remote control VF-80. To avoid unwanted adjustment, the lock and respective arrow button must be pressed simultaneously to set the direction.

28. Automatic Direction Adjustment/Locking

1. Install the drifting laser VL-80 in standing or suspended position using the positioning device. Level the box level (see 7.).
2. Connect the power supply to the laser and remote control.
3. Centre the device on middle position by pressing the arrow up and arrow down buttons at the same time.
4. Set the inclination of the **target beam**. Set the direction axis roughly by turning the laser and finely with the direction arrow buttons.
5. Set the locking laser beam on the required height.
6. Install the receiver with the **switch setting "Manual Side"** so that the locking laser beam falls on the centre of the solar cell cover.
7. Connect the locking receiver and VL-80 with the connection cable (74.25) and then open the solar cell cover.
8. Switch the drifting laser VL-80 off and then back on again to activate the locking receiver.
9. Adjust the direction of the solar cell unit with the knurled knob by hand until the green LED indicates middle position.
10. Switch the switch to "Auto On", thus activating the automatic direction function.
11. Check the direction of the target beam and correct with the knurled knob on the locking receiver if necessary.
12. The status "No Reception" and "Automatic Off" are shown in the LCD display of the laser (see 9.1) and on the remote control VF-80 by an LED and additionally by an acoustic signal. The volume can be adjusted with the keyboard.

Note: Proceed in the above order!

29. Safety Instructions

- Pay attention to the accident prevention regulations.
- Do not set up the laser at eye level.
- Do not look into the beam.
- Do not remove the warning signs on the laser.
- Check the laser before every use (control measurement).
The manufacturer and its dealers accept no liability for damage caused by faults and consequential damages.
- Only use the battery charger in dry rooms.
- Do not open the laser yourself.
Note: The laser power values in the device are far higher than prescribed for laser class 2 or 3B.
- Repairs requiring the device to be opened may only be carried out by authorized persons.

30. Troubleshooting

1. No laser beam - check power supply; low battery?
2. Low range - clean laser beam exit window.
3. Laser beam blinks slowly - move device into the levelling range by tilting forwards.
If the error is not corrected within 2.5 minutes, the device is switched off automatically.
4. Laser switched off automatically (kick guard) - switch on the device again.

31. Maintenance

The laser requires no special maintenance. Keep the electrical connections clean. Do not clean with water spray. Clean glass parts with a soft, clean cloth. Store dry. Always transport the laser in its original case.

Operation Instructions

Automatic-Drifting Laser VL-70/-80

Fixing the line - locked on target!

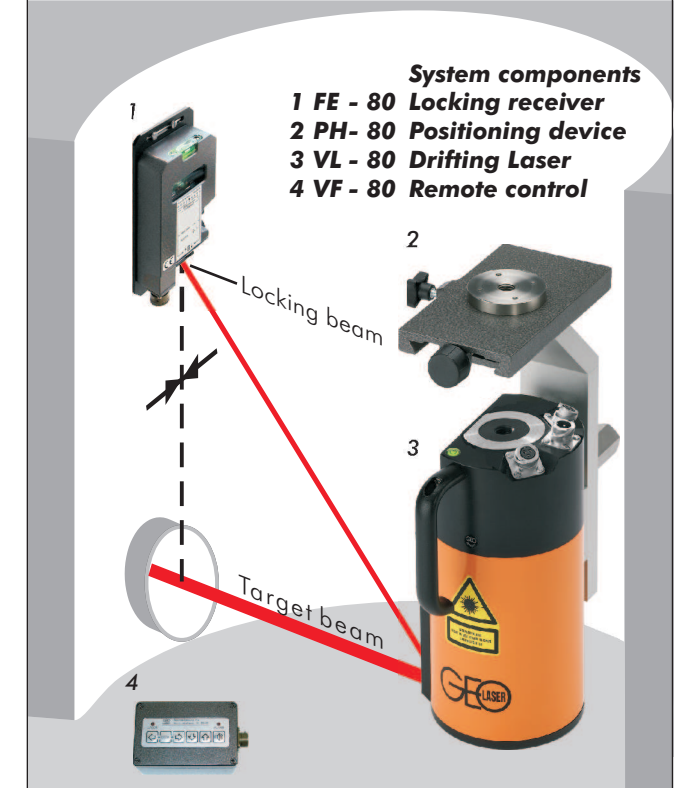

Congratulations on your new GEO laser

In addition to information on how to use the laser, these operating instructions also contain important safety instructions.

Read the operating instructions carefully before using the laser.

GEO-Feinmechanik GmbH
Solinger Straße 8 • D-45481 Mülheim • Tel.: 02 08 / 9 93 57-0 • Email: geo-team@geo-laser.de

Contents	Page
Quick Start Guide	1
1. Description	2
2. Parallel Height Adjustment	2
4. Parallel Side Adjustment	3
9.1 LCD Display	2
9.2 Adjustment Possibilities, Menu Level 2	3
13. Buttons	4
14. Changing the Factory Defaults	4
15. Locking Beam Height Adjustment	5
16. Switching the Locking Laser Beam On/Off	5
17. Receiver Status Symbols in LCD Display	5
18. Remote Control Status Symbols in LCD Display	5
19. VF-80 Drifting Laser Remote Control	5
20. Locking Receiver FE-80	6
21. Automatic Laser Cut-Out	7
22. Monitoring of Self-Levelling	7
23. Flicker Mode	7
24. Power Supply	7
25. Setting the Inclination	7
26. Calculating the Percentage	7
27. Setting the Direction	8
28. Automatic Direction Adjustment/Locking	8
29. Safety Instructions	8
30. Troubleshooting	8
31. Maintenance	8
32. Axis Transfer	9
33. Checking and Adjustment	10
34. Checking	10
35. Specifications	11
36. Standard Delivery Package VL-80	11
37. Standard Delivery Package VL-70	11
38. Optional Accessories	11
39. Service	11

Quick Start Guide

- 1 Set up the laser on line at the required height (see 32.).
- 2 Connect the cables.
- 3 Switch on the laser (see 13.1).
- 4 Set the required inclination (see 13.2).
- 5 Set the direction of the target beam (see 13.4 and 27.).
- 6 If necessary, switch on the locking laser beam (only VL-80). Press the button Menu/OK. The pointer appears in the display. Press Arrow Up / Down to switch on the locking laser beam and to set the height (see 15. und 16.) Then, for example, lock the beam with the receiver FE-80 (see 20.).
- 7 The remote control VF-80 can be connected for operation if wanted (see 19.).

1. Description

The VL-80 is a special laser especially developed for pipe driving, but which can also be used for many other purposes. It emits an automatically levelled or defined inclined target beam and a second beam for direction locking.

The advantageous diode laser beam features low power consumption with immense target beam laser power. It can be adjusted in five steps from 1 to < 5 mW for different requirements. The clearly visible locking beam is equipped with automatic laser output power optimisation. The laser has control indicators with blinking warning system for levelling, direction locking, low battery and end positions as well as a shift guard for the inclination and direction setting.

The values that have been set remain stored in the laser even after switching off or in the case of a low battery. The name of the owner can be saved in the device to protect against theft.

The VL-70 differs from the VL-80 in that it does not have a direction locking feature.

2. Parallel Height Adjustment

2.1 Tightening Screw

Note: Loosen before height adjustment, then tighten again.

2.2 Millimetre Rule

For height adjustment.

2.3 Lock Nut

Loosen before height adjustment, then tighten again.

2.4 Height Adjustment Screw

Loosen tightening screw 2.1 and lock nut 2.3, then set the height by turning.

3. Housing

Robust light-metal housing, plastic-coated, swept and filled with nitrogen, 100 % watertight.

9.1 LCD Display

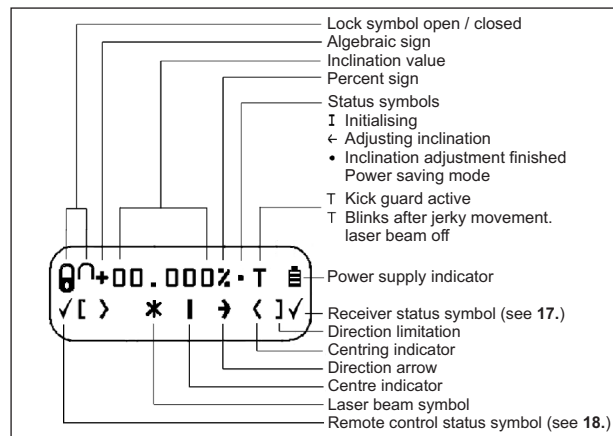

2

4. Parallel Side Adjustment

4.1 5/8" Tightening Thread

4.2 Side Adjustment Screw

Note: Loosen the fastening screw before adjustment, then tighten again.

4.3 Fastening Screw

Note: Loosen before side adjustment, then tighten again.

5. Power Supply

12 V DC/ 0.4 A

6. Receiver/Remote Control Connector

7. Box Level

Set up aid, for viewing from above.

8. Keyboard

Clear layout, big, user-friendly, self-explanatory keys.

9. LCD-Display

Clearly legible, illuminated display for on/off, company data, device data, inclination, operating status and battery level.

10. Handle

for easy handling, safe transport and simple set-up.

11. Laser Warning Sign

Laser class 3R, ≤ 5 mW, ≥ 25 W/m² (see 29.)

12. Laser Beam Exit Window

12.1 Locking Beam (only VL-80)

12.2 Target Beam

9.2 Adjustment Possibilities, Menu Level 2

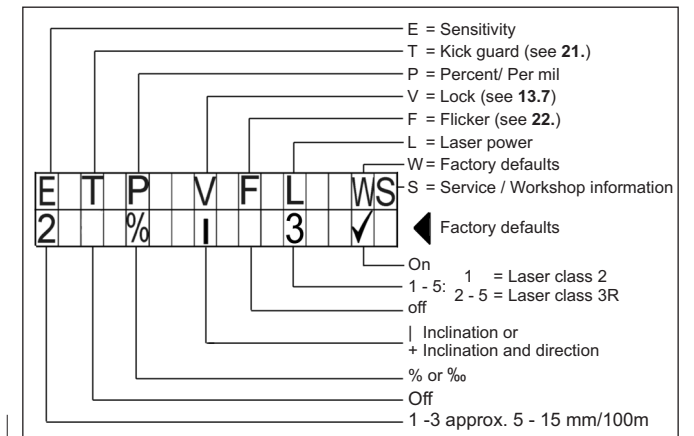

3

13. Buttons

 = 13.1 On/Off Button

The device is switched on by pressing this button.

Note: If the laser is to be used with direction locking, the device must be connected to the locking receiver and remote control before being switched on.

The device and company data are then shown, followed by the operating display with the last settings without button lock. The device is then levelled and referenced on the zero point automatically. After the levelling phase the laser beam and laser beam symbol stop blinking. If this does not happen, the device must be moved into the levelling range by tilting it forwards. To switch off the device, press the On/Off button until "Auf Wiedersehen!" appears.



 or  = 13.2 Inclination Setting

Note: The gradient/inclination is shown in % or ‰, not in degrees or gon.



Pressing the arrow button changes the inclination value by 0.001 %. The value is changed with increasing speed if the button is kept pressed.

 +  = 13.3 Setting Inclination on Zero

The inclination value is set on 0.000 % by pressing the two arrow buttons at the same time.

 or  = 13.4 Direction Setting

After setting one of the two arrow buttons the laser beam symbol changes to an arrow. It indicates the direction of movement and the current position. When end position is reached, the laser beam and limitation symbol begin to blink. The setting must then be moved back within 2.5 minutes. If this is not done, the laser is switched off automatically.

 +  = 13.5 Direction Centring

After pressing the two arrow buttons the device is automatically centred in middle position.

13.6 Quick Setting

In addition to the respective arrow buttons also press the On/Off button.



 = 13.7 Button Lock
(alternatively inclination or inclination + direction see 9.2; V = Lock)



Press the button 2 x: the lock symbol begins to blink, press arrow up or arrow down button. The buttons are protected against accidental adjustment. Press the Menu button 2 x again, press the arrow up or arrow down button. The lock is lifted.

14. Changing the Factory Defaults

 = 14.1. Select Menu Level

Keep the button pressed until the adjustment possibilities shown in 9.2



 or  = 14.2 Select Letter
The selected letter begins to blink.

 or  = 14.3 Change Settings

 = 14.4 Back to Operating Display

15. Locking Beam Height Adjustment (only VL-80)

 Press 1 x until the "Pointer" appears.
The external remote control and automatic direction setting function do not work!

 or  A direction arrow appears in the display. Long pressing changes the locking beam height with increasing speed until the direction arrow begins to blink. The height then changes without the button having to be pressed until the locking beam hits the receiver, a direction arrow is pressed or end position is reached (blinking direction arrow changes to a square).

Quick Setting

In addition to the respective arrow button also press the

 Back to operating display.

16. Switching the Locking Laser Beam On/Off (only VL-80) (only when working without locking receiver)

 Press 1 x until the "pointer" appears.
The remote control does not work!

 The locking laser beam can be switched on/off by long pressing of the button.

 Back to operating display.

17. Receiver Status Symbols in LCD Display (only VL-80)

- ✓ = direction locking OK
- E = no connection (check cable connections)
- = not run in (refraction or oscillations)
- ? = no reception (obstacle in beam path)
- | = direction locking switched off on receiver
- = operation without receiver

18. Remote Control Status Symbols in LCD Display

- ✓ = remote control OK
- E = no connection (check cable connection)
- = when button is pressed.

19. VF-80 Drifting Laser Remote Control

For direction setting of the target beam and locking beam, for height setting of the locking beam, for visual and auditory status.

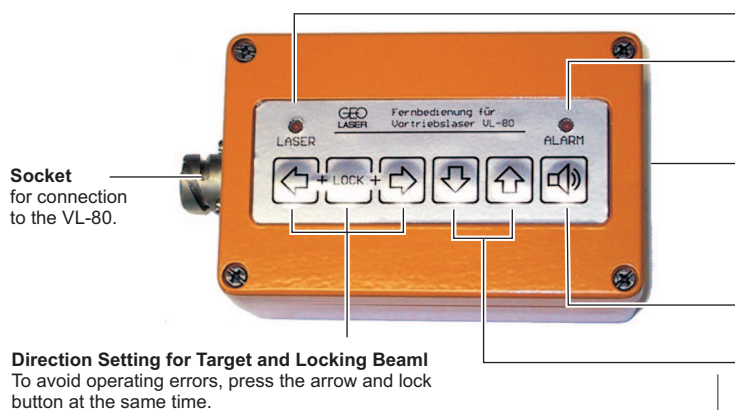

Direction Setting for Target and Locking Beam!
To avoid operating errors, press the arrow and lock button at the same time.

20. Locking Receiver FE-80 (only VL-80)

The FE-80 locking receiver makes monitoring and automatic locking of the target beam possible. The integrated LED indicators are used for set-up and status control. Installation see 27.

Note: The FE-80 is not intended for calibration of the direction axis. This must be done directly with the target beam!

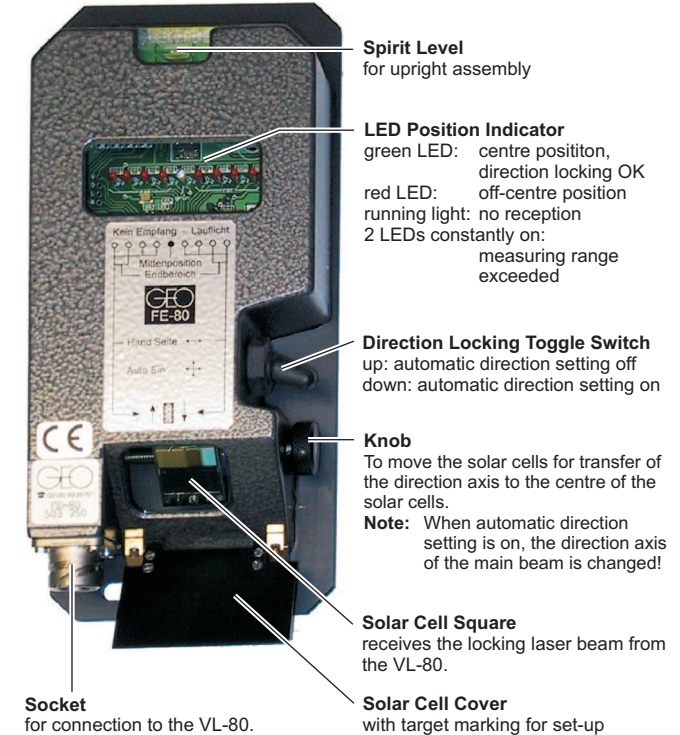

Laser Control LED
blinks in time with the target beam

Error LED
off: system working properly
on: direction locking fault (see 17.) Kick guard actuated

Alarm
An intermittent alarm is emitted 5 sec. after the error LED lights up. This changes to a continuous alarm after 2 min. The intermittent alarm stops when the error is corrected. The continuous alarm must be stopped by pressing the volume button.

Alarm Volume / Clear Alarm
Adjustable in 4 steps: off, quiet, middle, loud

Locking Beam Height Adjustment (only VL-80)
Long pressing changes the locking beam height with increasing speed.

32. Axis Transfer

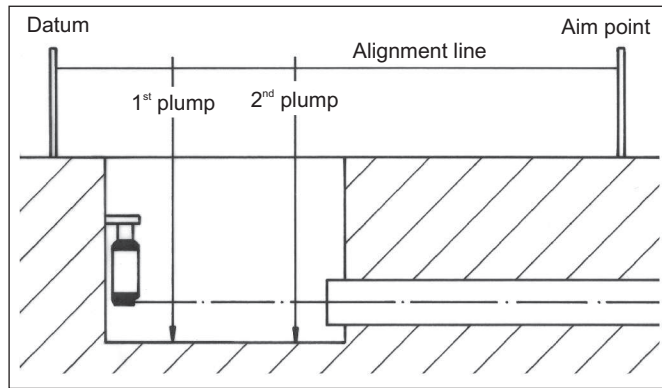

1. To find the driving axis, connect the datum and the aim point with a line.
2. Transfer the axis downwards into the construction ditch at two points along this line. The two points should be as far apart as possible.
3. Adjust the laser beam on the first plumb by parallel traversing directly at the laser beam and on the second plumb by a rotational movement in the direction.

To achieve greater precision, a geodesic calibration is recommended.

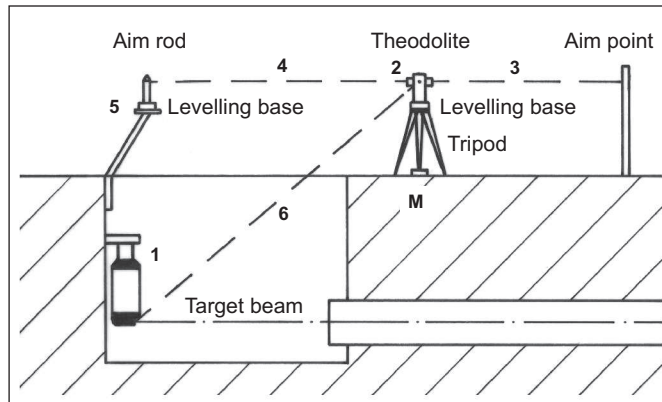

1. Set up the laser at the correct height and align roughly.
2. Centre and level the theodolite over the measuring point (M). The measuring point may also be behind the construction ditch.
3. Align on the aim point.
4. Transit the theodolite telescope and aim at the aim rod.
5. Push and fix the aim rod levelled with the levelling base into the axis.
6. Transfer the axis into the construction ditch using the theodolite and place the laser beam in the axis by parallel traversing of the laser.

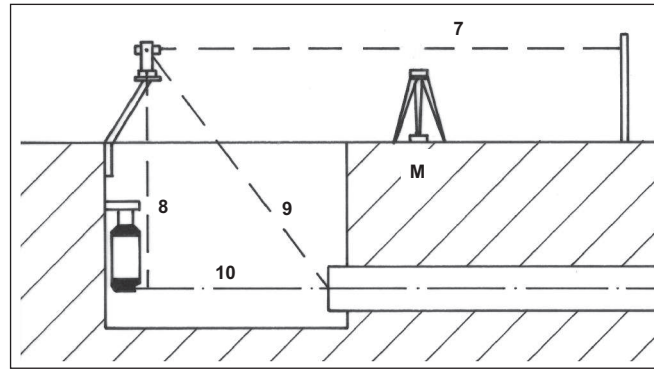

7. Swap the aim rod for the theodolite and aim at the aim point.
8. The theodolite's plumb axis must correspond with the laser beam.
9. Transfer the axis into the construction ditch with the theodolite.
10. Set the laser beam in the axis using the directional adjustment.
11. Check point 8 again, correct errors, repeat points 9 and 10.
12. To increase accuracy, carry out measurement in the first and second telescope positions.

33. Checking and Adjustment

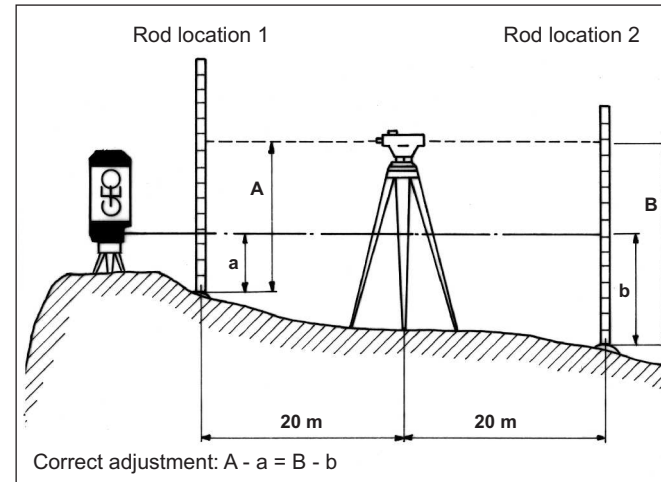

34. Checking

Although the laser is adjusted precisely by the manufacturer, jolts and strong vibrations can lead to this adjustment being lost. The laser should therefore be checked before use.

1. Select a measuring area that is as level as possible and around 40 m long and set up the laser with the counter on "000.00".
2. Set up two measurement points - one directly in front of the laser and the other around 40 m from it - and measure the distance on the centre of the laser beam.
3. Set up a levelling instrument between the two measurement points and measure both rod locations.
4. The adjustment is correct when the rod section $A - a$ is equal to the rod section $B - b$ (sketch 1).

35. Specifications

Locking beam: class 2, < 1mW, red 635 nm
 Locking beam Ø: 5 mm at laser, approx. 13 mm at 15 m
 Target beam (only VL-80): class 3R, < 5 mW, red 658 nm
 Target beam core Ø (only VL-70): 13 mm at laser, + approx. 5.5 mm per 100 m
 Range depending on ambient conditions: up to 500 m

Direction setting range: $\pm 5\%$ (10 m over 100 m)
 Automatic direction function (only VL-70): in combination with FE-80
 Distance between VL-80 and FE-80: 2 to 15 m
 Inclination adjustment range locking beam (only VL-70): - 2.5 % to 110 ° (48°)

Inclination adjustment range target beam: - 10 % to + 40 %
 Reading accuracy: 0.001 %
 Permissible deviation: $\pm 0.005\%$
 Adjustment: possible without having to open the device

Power supply: 10 to 13.8 V DC/ 0.4 A
 Reverse voltage protection and low battery cut-out: yes
 Watertight: 0.35 bar
 Temperature range: - 10° C to + 50° C
 Weight: VL-80 3.1 kg + PH-80 2.2 kg = 5.3 kg
 Guarantee: 12 months

36. Standard Delivery Package VL-80

0001.500	VL-80	Drifting laser
0077.26		Transport case VL-80
0062.01	PH-80	Positioning device, suspended
0065.06	FE-80	Locking receiver
0026.06	VF-80	Drifting laser remote control
0047.00		Battery connector, 2-pole C
0031.00		Connection cable, 2.5 m, 2-pole C
0074.25		Cable, 20 m, 3-pole C, VL-80 <> FE-80/VF-80 (2 pcs.)
0094.00.1		5/8" hexagon bolt with nut and washer

37. Standard Delivery Package VL-70

0001.900	VL-70	Drifting laser
0077.26		Transport case VL-80
0062.01	PH-80	Positioning device, suspended
0047.00		Battery connector, 2-pole C
0031.00		Connection cable, 2.5 m, 2-pole C
0094.00.1		5/8" hexagon bolt with nut and washer

38. Optional Accessories

0071.01	PS-80	Positioning device, standing
0095.00.1		5/8" threaded spindle with 3 x hex nuts
0037.09	NE-12/2A	Power supply with connection cable, 2 m
0048.01	EB-12/24	Energy box, 12 V/ 24 Ah
0031.36		Connection cable, 10 m, 2-pole

39. Service

Our devices are covered by a 12-month guarantee. Unauthorized opening of the devices invalidates the guarantee. Please always send the laser in for inspection or repair in its original case. Always specify the faults.

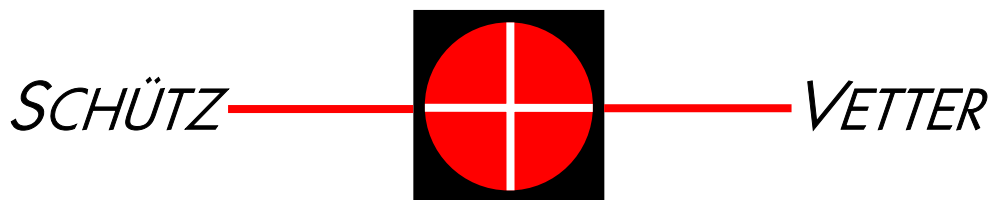

BAULASER UND VERMESSUNGSGERÄTE

VL-70 und VL-80

Information on power supply

The following points on power supply must be heeded for the drifting lasers VL-70 and VL-80.

Non-compliance can lead to destruction of the laser electronics !

- The laser housing is connected to the minus pole of the power supply. The steel construction to which the laser is fastened must therefore also be connected to the minus pole. To increase safety, it must also be earthed.
- If this is not possible, a power supply that is galvanically isolated from the steel construction must be used for the laser (e. g. rechargeable battery).
- All cable connections at the laser must always be disconnected when Welding.
- The permissible operating voltage at the laser is approx. 10 to 14.2 V. Between 14.2 V and 15.5 V the laser is switched off with an alarm.
- At operating voltages above 15.5 V a protective circuit in the laser is destroyed and the laser must be sent in for repair!
- If the laser is run on a generator, the operating voltage may only be connected when the generator voltages have stabilised. It does not suffice to switch off the laser!
- The power supply should likewise be disconnected from the laser before switching off the generator.

Werkvertretung: GEO-Feinmechanik GmbH, Mülheim/R für: Tiefbau-, Hochbau-, Innenausbaulaser, Lasierzubehör
BERATUNG • VERKAUF • REPARATUR • VERMIETUNG • SONDERANFERTIGUNG • SCHULUNG

SCHÜTZ+VETTER GMBH
KIRCHSTRASSE 13
64395 BRENSBACH
[www: schuetz-vetter.de](http://www.schuetz-vetter.de)

TELEFON:
06161 – 912010 / 11
TELEFAX
06161 / 912012

BANKVERBINDUNG:
SPARKASSE ODW.-KREIS
BLZ: 50851952
KTO.-NR.: 70900600

GERICHTSSTAND:
AMTSGERICHT DARMSTADT HRB:71046
GESCHÄFTSFÜHRER
DIPL. ING. ACHIM VETTER