

## Electric Control Valves

Type 3222/5857, Type 3222/5824, Type 3222/5825

## Pneumatic Control Valves

Type 3222/2780-1, Type 3222/2780-2



*Type 3222/5857 Electric Control Valve*



*Type 3222/5825 Electric Control Valve*



*Type 3222/2780-1 Pneumatic Control Valve*



*Type 3222/2780-2 Pneumatic Control Valve  
with Type 3760 Positioner*

## Mounting and Operating Instructions

**EB 5866 EN**

Edition October 2009



## Definitions of the signal words used in these instructions

---

### **DANGER!**

*DANGER indicates a hazardous situation which, if not avoided, will result in death or serious injury.*

---

---

### **WARNING!**

*WARNING indicates a hazardous situation which, if not avoided, could result in death or serious injury.*

---

---

### **NOTICE**

*NOTICE indicates a property damage message.*

---

**Note:** *Supplementary explanations, information and tips*

---

Contents	Page
<b>1</b>	<b>General safety instructions</b> . . . . . 5
<b>2</b>	<b>Design and principle of operation</b> . . . . . 6
2.1	Versions . . . . . 6
2.2	<b>Typetesting</b> . . . . . <b>6</b>
2.3	Technical data for Type 3222 Globe Valve . . . . . 8
2.3.1	Nameplate . . . . . 9
2.3.2	Customer inquiries . . . . . 9
<b>3</b>	<b>Installation</b> . . . . . 10
3.1	Mounting position . . . . . 10
3.2	Strainer . . . . . 10
3.3	Additional installation instructions . . . . . 10
<b>4</b>	<b>Combination with Type 5857 Electric Actuator</b> . . . . . 11
4.1	Technical data for actuator . . . . . 11
4.2	Mounting the actuator to the valve . . . . . 12
4.3	Electrical connection . . . . . 12
<b>5</b>	<b>Combination with Types 5824/5825 Electric Actuators</b> . . . . . 15
5.1	Technical data for actuators . . . . . 15
5.2	Attaching the actuator to the valve . . . . . 18
5.3	Electrical connection . . . . . 19
<b>6</b>	<b>Combination with Type 2780 Pneumatic Actuator</b> . . . . . 22
6.1	Technical data of actuators . . . . . 22
6.2	Mounting the actuator onto the valve . . . . . 22
6.3	Pneumatic connection . . . . . 22
<b>7</b>	<b>Maintenance</b> . . . . . 23
<b>8</b>	<b>Dimensions in mm and weights</b> . . . . . 24

---

**Note:** More detailed information on actuators can be found in the Mounting and Operating Instructions of the actuators, which are available on the Internet at [www.samson.de](http://www.samson.de).

- Type 5857 Electric Actuator - see EB 5857 EN
  - Type 5824/5825 Electric Actuator - see EB 5824 EN
  - Type 2780 Pneumatic Actuator - see 5840 EN
-



## 1 General safety instructions

For your own safety, follow these instructions concerning the mounting, start up and operation of the control valve:

- ▶ The control valves must be installed, started up and serviced by fully trained and qualified personnel only, observing the accepted industry codes and practices. Make sure employees or third persons are not exposed to any danger. All safety instructions and warnings in these mounting and operating instructions, particularly those concerning installation, start-up and maintenance, must be observed.
- ▶ For appropriate operation, make sure that the control valve is only used in applications where the operating pressure and temperatures do not exceed the operating values based on the sizing data submitted in the order.  
Note that the manufacturer does not assume any responsibility for damage caused by external forces or any other external factors.  
Any hazards which could be caused in the control valve by the process medium or operating pressure are to be prevented by means of appropriate measures.
- ▶ For installation and maintenance, make sure the relevant section of the pipeline is depressurized and, depending on the process medium, drained as well. If necessary, allow the control valve to cool down or warm up to reach ambient temperature prior to starting any work on the valve.
- ▶ The actuators are designed for use in low voltage installations.  
For wiring and maintenance, you are required to observe the relevant safety regulations.
- ▶ Take necessary measures to ensure that the power supply cannot be reconnected inadvertently.
- ▶ Take care while performing adjustment work on live parts. Never remove any covers!

To avoid damage to any equipment, the following also applies:

- ▶ Proper shipping and appropriate storage are assumed.

---

**Note:** The control valves fulfill the requirements of the European Pressure Equipment Directive 97/23/EC. Valves with a CE marking have a declaration of conformity which includes information about the applied conformity assessment procedure. The declaration is available on request.

---

## 2 Design and principle of operation

The control valves consist of a single-seated Type 3222 Globe Valve and either a Type 5857 or Type 5824 Electric Actuator or a Type 5825 Electric Actuator with fail-safe action or, alternatively, with a Type 2780-1 Pneumatic Actuator or Type 2780-2 Pneumatic Actuator for integral positioner attachment.

The process medium flows through the valve in the direction indicated by the arrow on the body. The position of the valve plug determines the flow rate over the cross-sectional area of flow released between the plug (3) and valve seat (2). The plug stem (4) with plug is connected with the stem of the actuator (10) by a force-locking connection. The valve is opened by the valve spring (5) following the movement of the actuator stem.

The plug is moved by a change in the control signal acting on the actuator. The electric actuators work with a three-point stepping control signal or, in case an additional positioner is used, with a continuous signal (0 to 10 V in Type 5857, 0 to 10 V or 0 to 20 mA in Types 5824/5825 depending on the configuration).

Electric actuators with fail-safe function have a spring mechanism which is connected to the motor by a clutch. An electromagnet disengages the clutch when the power supply fails or when the control circuit is interrupted. Depending on the actuator version, the valve is closed or opened. The version with "Actuator stem extends" is closed in

case of emergency, whereas the version with "Actuator stem retracts" is opened.

The Type 2780-1 Pneumatic Actuator is controlled by a signal pressure of 0.4 to 1 bar which is applied to the loading pressure connection. Type 2780-2 uses signal pressures between 0.4 and 2 bar. These actuators are available with fail-safe action "Actuator stem extends" and "Actuator stem retracts". Type 2780-2 can additionally be equipped with Type 3760 Positioner.

### 2.1 Versions

	PN	DN
<b>Electric control valves</b>		
Type 3222/5857	25	15 to 25
Type 3222/5824	25	15 to 50
... with fail-safe action		
Type 3222/5825	25	15 to 50
<b>Pneumatic control valves</b>		
Type 3222/2780-1	25	15 to 50
... for integral positioner attachment		
Type 3222/2780-2	25	15 to 50

### 2.2 Typetesting



The Type 5825 Electric Actuators with fail-safe action used in conjunction with Type 3222 Valves are typetested according to DIN 32730 by the German technical inspectorate TÜV.

The register number is available on request.

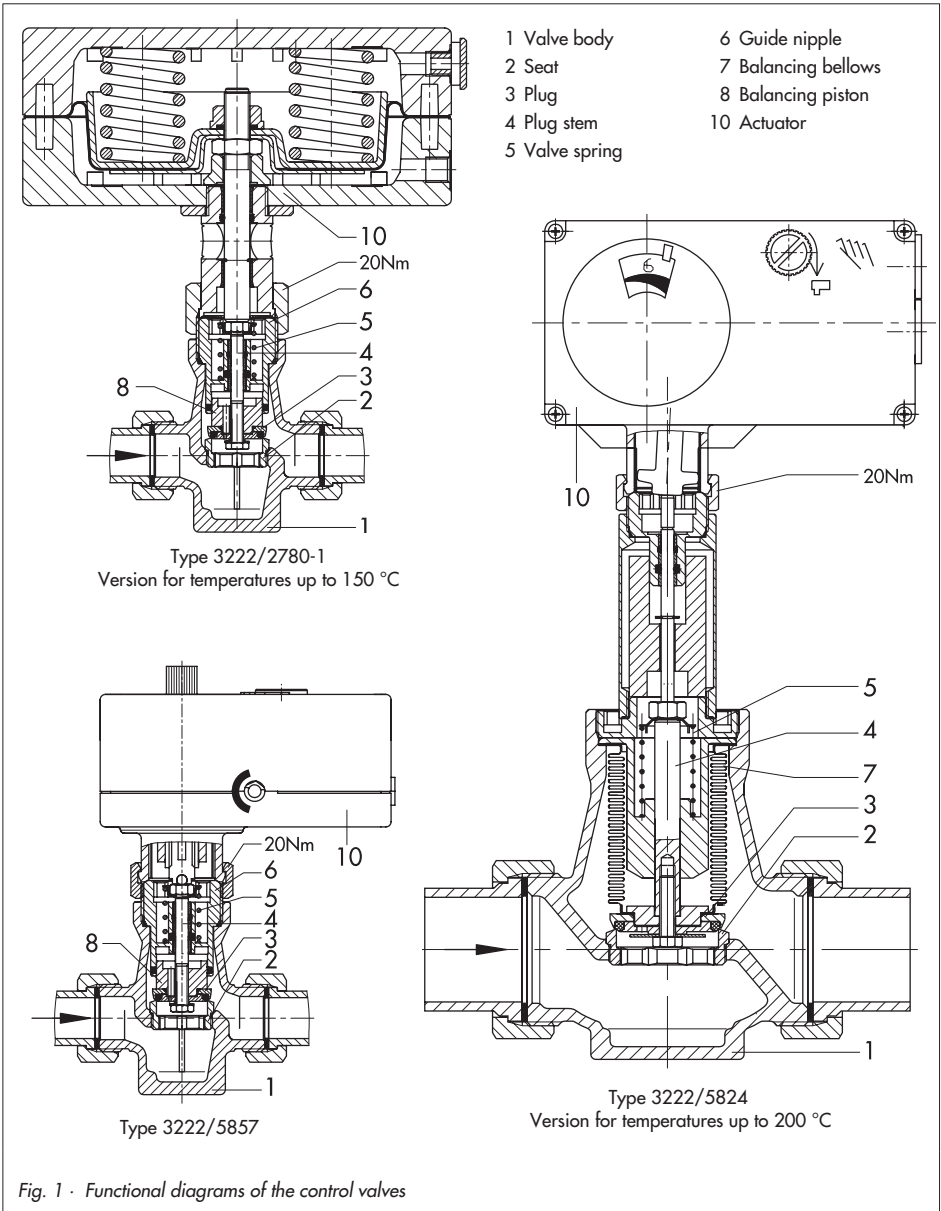

Fig. 1 - Functional diagrams of the control valves

## 2.3 Technical data for Type 3222 Globe Valve

<b>Nominal size</b> Version with threaded ends, flanges or as flanged body	DN	15	20	25	32	40	50
<b>Thread size</b> Version with female thread	G	½	¾	1	–	–	–
Nominal pressure	PN	25					
Seat/plug sealing		Metal sealing for $K_{VS} \leq 2.5$ · Soft sealing for $K_{VS} \geq 3.6$					
Rated travel	mm	6			12		
Rangeability		50 : 1					
Leakage class acc. to DIN EN 1349		Class I (< 0.05 % of $K_{VS}$ coefficient)					
<b>Version for water, oil and other liquids</b>							
Max. permissible temperature		150 °C <sup>1, 2)</sup>					
Max. permissible differential pressure $\Delta p$ in bar							
	Types 5824 and 5825	20			12		
	Type 5857	20			–		
<b>Version for water and steam</b>							
Max. permissible temperature		200 °C					
Max. permissible differential pressure $\Delta p$ in bar							
	Types 5824 and 5825	20 · 10 for $3.6 \leq K_{VS} \leq 8$			8		
	Type 5857	20 <sup>3)</sup> · 5 <sup>4)</sup>	5		–		
<b>Materials</b>							
Valve body		Red brass CC491K · EN-JS1049 (flanged body)					
Seat		Stainless steel 1.4104					
Plug		1.4104/CW509L with soft sealing · 1.4104 for $0.1 \leq K_{VS} \leq 2.5$					
Valve spring		Stainless steel 1.4310 K					
Packing		EPDM/FPM (FKM) · Oil-resistant version: FPM					
Welding ends		St 37					
Threaded ends		Red brass CC491K					
Screwed-on flanges		St 37.2					

1) Use an intermediate insulating piece or temperatures > 130 °C to protect the actuator

2) DN 15 to 25 with Type 5857 Actuator for liquids up to 120 °C

3) Differential pressure for  $K_{VS} = 1$  and 1.6

4) Differential pressure for  $K_{VS} = 2.5$  and 4



Nominal size	DN	15	20	25	32	40	50
Thread size	G	½	¾	1	–	–	–
K <sub>VS</sub> coefficients		4 <sup>1)</sup> · 3,6 <sup>2)</sup>	6,3 <sup>1)</sup> · 5,7 <sup>2)</sup>	8 <sup>1)</sup> · 7,2 <sup>2)</sup>	16 <sup>1)</sup>	20 <sup>1)</sup>	25 <sup>1)</sup>
Reduced K <sub>VS</sub> coefficients		0.1 · 0.16 · 0.25 · 0.4 0.63 · 1.0 · 1.6 · 2.5	1.0 · 1.6 · 2.5 4 <sup>1)</sup> · 3,6 <sup>2)</sup>		–	–	–
Rated travel	mm	6			12		

1) Version with male thread

2) Version with female thread

### 2.3.1 Nameplate

<b>SAMSON</b>	1
2	3
4	5
K <sub>VS</sub> 6	Δp 7

1 Type designation

2 Configuration ID (Var.-ID)

3 Date of manufacture

4 Model number

5 Max. permissible temperature

6 K<sub>VS</sub> coefficient

7 Max. permissible differential pressure

### 2.3.2 Customer inquiries

Please submit the following details:

- ▶ Type designation
- ▶ Configuration ID (Var.-ID)
- ▶ Date of manufacture

### 3 Installation

If the valve and actuator are delivered separately, first install the valve into the pipeline before mounting the actuator.

---

**NOTICE**

*Versions designed to handle temperatures up to 200 °C must be fitted with the dark gray graphite supplied with the valve. Do not use the UDP seals available as accessories as they are only suitable for temperatures up to 150 °C.*

---

#### 3.1 Mounting position

- ▶ Choose the place of installation where the ambient temperature does not exceed or fall below the permissible limits specified for the actuator and that allows you to freely access the control valve even after the entire plant has been completed.
- ▶ Flush the pipeline thoroughly before installation.
- ▶ Do not install the valve with the actuator suspended downwards.  
Install versions for water and steam up to 200 °C with the actuator installed upright in a horizontal pipeline.
- ▶ If you wish to insulate the control valve, install an intermediate insulating piece between valve and actuator. Make sure the insulation ends 25 mm above the valve body. Do not insulate the actuator and coupling nut as well.
- ▶ Install a strainer (SAMSON Type 2 NI) upstream of the control valve to prevent any sealing parts, weld spatter or other foreign matter carried along by the pro-

cess medium from impairing the proper functioning of the valve, in particular, the tight shut-off.

- ▶ The valve must be installed free of stress. If necessary, support the piping near the connections.

#### 3.2 Strainer

- ▶ Install the strainer with the filter element facing downwards upstream of the valve inlet.
- ▶ Choose the place of installation to allow enough space to remove the filter.
- ▶ Install the strainer with the flow direction as indicated by the arrow on the body.

#### 3.3 Additional installation instructions

We recommend to install a hand-operated shut-off valve both upstream of the strainer and downstream of the control valve to be able to shut down the plant for cleaning and maintenance, and when the plant is not used for longer periods of time.

## 4 Combination with Type 5857 Electric Actuator

### 4.1 Technical data for actuator

Type 5857 Actuator	Version	Three-point stepping version	With digital positioner
Connection to valve		Force-locking	Force-locking
Rated travel		6 mm	6 mm
Transit time for rated travel		20 s	30/20 <sup>2)</sup> /10 s <sup>1)</sup>
Nominal thrust		300 N	300 N
Power supply		230 V (±10 %), 50 Hz 24 V (±10 %), 50 Hz	24 V AC (±10 %), (50 and 60 Hz) 24 V DC (±10 %) <sup>3)</sup>
Power consumption		Approx. 3 VA	5 VA
Manual override		Yes	Yes
Permissible ambient temperature		0 to 50 °C	0 to 50 °C
Permissible storage temperature		-20 to 70 °C	-20 to 70 °C
Degree of protection		IP 42	IP 42
Protection class		II	II
Noise immunity		EN 61000-6-2	EN 61000-6-2
Noise emission		EN 61000-6-3	EN 61000-6-3
Weight		Approx. 0.7 kg	Approx. 0.7 kg
<b>Digital positioner</b>		–	
Input signal			0 to 10 V <sup>1)</sup>
Position feedback		–	0 to 10 V <sup>1)</sup>
Characteristic			Linear <sup>1)</sup>

<sup>1)</sup> Value adjustable in TROVIS-VIEW Configuration and Operator Interface. Refer to EB 5857 EN for more details (also included in TROVIS-VIEW).

<sup>2)</sup> Default setting

<sup>3)</sup> 10 s applies to 24 V DC (-0 %, +10 %) for *Transit time for rated travel* setting

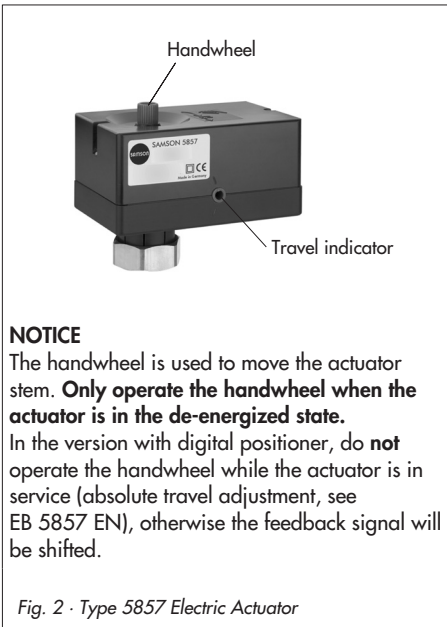

## 4.2 Mounting the actuator to the valve

1. Turn the handwheel (Fig. 2) counter-clockwise **only after disconnecting the actuator from the power supply** to retract the actuator stem as far as it will go.
2. Place the actuator on the valve connection or the intermediate insulating piece and secure with the coupling nut (tightening torque 20 Nm).

## 4.3 Electrical connection



### **DANGER!**

#### **Risk of electric shock!**

When installing electric cables, you are required to observe the regulations governing electrical power plant installation according to DIN VDE 0100 as well as the regulations of your local power supply company.

Use a suitable power supply which guarantees that no dangerous voltages reach the device in normal operation or in case of a fault in the system or any other system parts.

Connect the actuator to the electrical network only after the power supply is first switched off. Make sure the power cannot be switched on unintentionally! Especially when a 24 V voltage supply is used, wires with sufficiently large wire cross-sections must be used to guarantee that the permissible voltage tolerances of  $\pm 10\%$  are not exceeded!

## Three-point stepping version

- ▶ Connect the cable as shown in Fig. 3, observing the following instructions.
- ▶ If a voltage is applied to **eL**, the actuator stem retracts into the actuator (direction of action "Stem retracts").
- ▶ If a voltage is applied to **aL**, the actuator stem extends out of the actuator (direction of action "Stem extends").

### Important note:

- ▶ Decoupling capacitors  $C_e$  in the output circuit of the connected controller may not exceed a value of 2.5 nF in order to guarantee the proper functioning of the actuator.

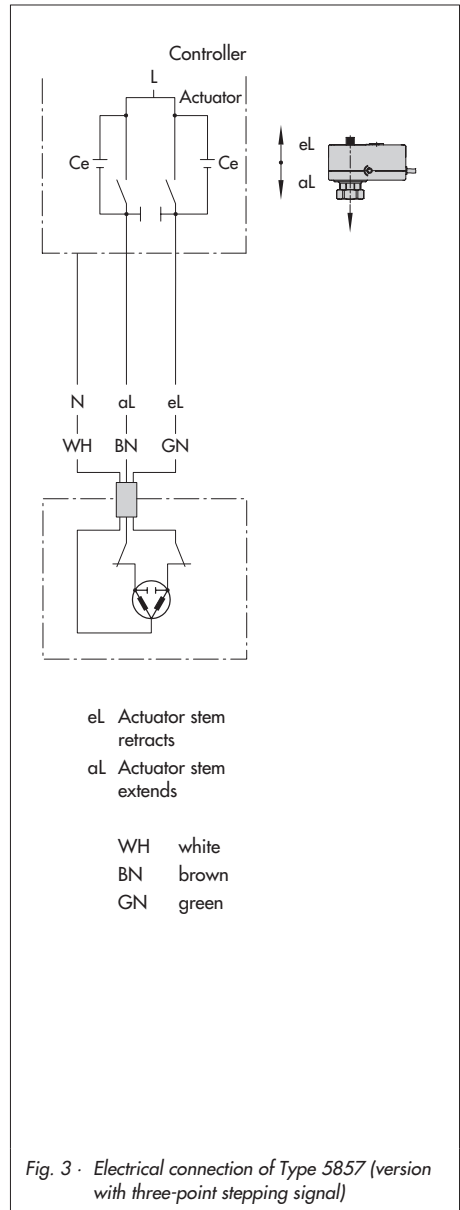

Version with digital positioner

**WARNING!**

Directly after connecting the voltage to the actuator, a zero calibration is automatically performed when the absolute travel adjustment is set (state of delivery), causing the actuator stem to move.

Do not touch the actuator stem or obstruct it to avoid risk of injury to hands or fingers.

**NOTICE**

During zero calibration, the control valve moves through a part of the travel range. As a result, do not connect the wires of the actuator while a process is running. Instead, close the shut-off valves in the plant first.

Connect the 6-wire cable according to Fig. 4.

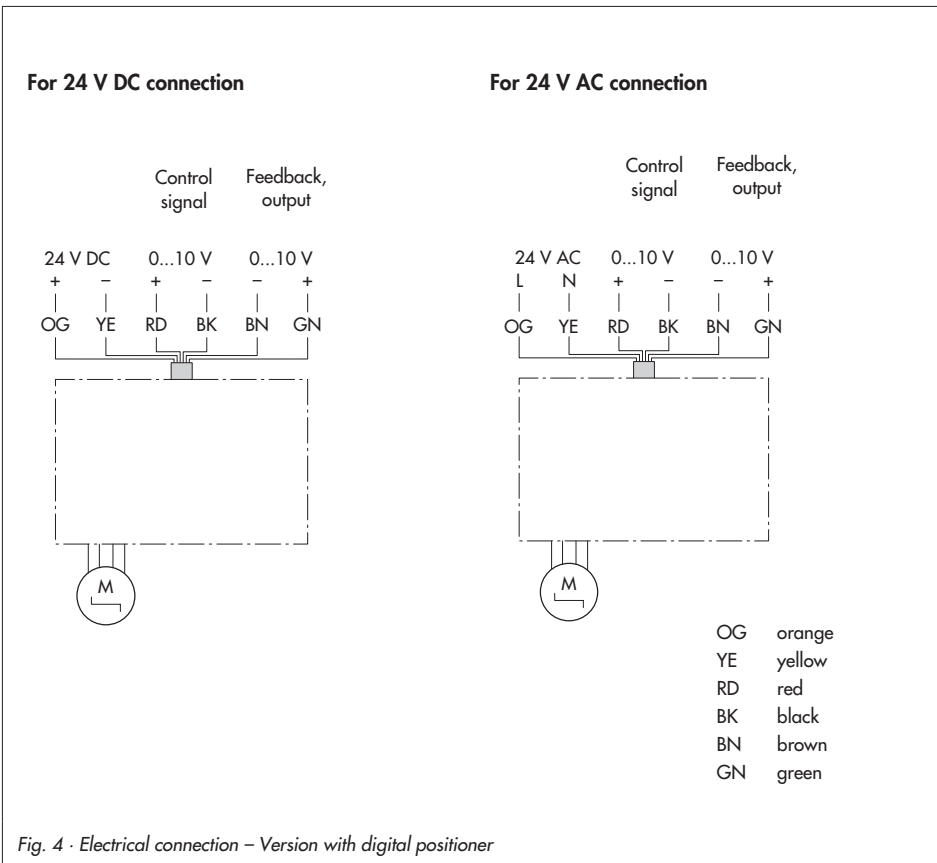

## 5 Combination with Types 5824/5825 Electric Actuators

### 5.1 Technical data for actuators

#### Three-point stepping version

Three-point stepping version	Type	5824				5825					
		-10	-13	-20	-23	-10	-13	-20	-23	-15	-25
Fail-safe action		Without				With					
Direction of action		-				Stem extends				Stem retracts	
Rated travel	mm	6 <sup>1)</sup>	6	12	12	6 <sup>1)</sup>	6	12	12	6 <sup>1)</sup>	12
Transit time for rated travel	s	35 <sup>1)</sup>	18	70	36	35 <sup>1)</sup>	18	70	36	35 <sup>1)</sup>	70
Transit time in case of fail-safe action	s	-				4	4	6	6	4	6
Nominal thrust	Stem extends	N	700	700		500			500		
	Stem retracts	N	-		-			-			
Nominal thrust of safety spring	N	-		500			- <sup>3)</sup>				
Attachment		Force-locking				Force-locking			Form-fit		
Power supply											
	24 V, 50 Hz	•		•		•		•		•	•
	230 V, 50 Hz	•	•	•	•	•	•	•	•	•	•
	120 V, 60 Hz	•		•		•		•		•	•
Power consumption	approx. VA	3	6	3	6	4	8	4	8	4	4
Manual override		Yes				Optional <sup>2)</sup>					
Permissible temperatures											
	Ambient	0 to 50 °C									
	Storage	-20 to 70 °C									
	At the connecting stem	0 to 130 °C									
Degree of protection		IP 54 (upright position, according to DIN IEC 529)									
Class of protection		II (according to VDE 0106)									
Overtoltage category		II (according to VDE 0106)									
Degree of contamination		2 (according to VDE 0110)									

## Combination with Types 5824/5825 Electric Actuators

Three-point stepping version	Type	5824				5825					
		-10	-13	-20	-23	-10	-13	-20	-23	-15	-25
Fail-safe action		Without				With					
Noise immunity		EN 61000-6-2									
Noise emission		EN 61000-6-3									
Weight	Approx. kg	0.75	1.00	0.75	1.00	1.00	1.25	1.00	1.25	1.00	1.00
<b>Additional electrical equipment</b>											
<b>2 limit switches</b> · max. 230 V, 3 A; cannot be retrofitted!		•	•	•	•	•	•	•	•	•	•
<b>1 potentiometer</b> · 0 to 1000 Ω ±15 % (90 % of final value at rated travel); max. 1 mA, 5 V		•		•		•		•		•	•
<b>Materials</b>											
Housing, housing front cover		Plastic (PPO glass fiber reinforced)									
Coupling nut		Brass									

1) Actuators with 6 mm travel can also be used for valves with 7.5 mm travel (45 s transit time).

2) Manual override using a 4 mm Allen key after removing housing front cover, always returns to fail-safe position after release

3) Safety spring pulls the actuator stem into the retracted end position; valve operated over the valve spring

## Version with digital positioner

Version with digital positioner	Type	5824		5825			
		-10	-20	-10	-20	-15	-25
Fail-safe action		Without		With			
Direction of action		–		Stem extends		Stem retracts	
Rated travel	mm	6	12	6 <sup>1)</sup>	12	6 <sup>1)</sup>	12
Transit time for rated travel <sup>2), 4)</sup>	s	45/ 31 <sup>3)/17</sup>	89/ 61 <sup>3)/33</sup>	45/ 31 <sup>3)/17</sup>	89/ 61 <sup>3)/33</sup>	45/ 31 <sup>3)/17</sup>	89/ 61 <sup>3)/33</sup>
Transit time in case of fail-safe action	s	–		4	6	4	6
Nominal thrust	Stem extends	N		500		500	
Nominal thrust of safety spring	N	–		500		– <sup>5)</sup>	
Attachment		Force-locking		Force-locking			



Version with digital positioner	Type	5824		5825			
		-10	-20	-10	-20	-15	-25
Fail-safe action		Without		With			
Power supply <sup>7)</sup>							
24 V DC (-10 %, +20 %)		•		•			
24 V, 50 and 60 Hz		•		•			
Power consumption	VA	5		8			
Manual override		Yes		Optional <sup>6)</sup>			
Permissible temperatures							
Ambient		0 to 50 °C					
Storage		-20 to 70 °C					
At the connecting stem		0 to 130 °C					
Degree of protection		IP 54 (upright position, according to DIN IEC 529)					
Class of protection		II (according to VDE 0106)					
Overvoltage category		II (according to VDE 0106)					
Degree of contamination		2 (according to VDE 0110)					
Noise immunity		EN 61000-6-2					
Noise emission		EN 61000-6-3					
Weight	Approx. kg	0.75		1.00			
<b>Additional electrical equipment</b>							
2 limit switches - max. 230 V, 3 A; cannot be retrofitted!		•		•			
<b>Materials</b>							
Housing, housing front cover		Plastic (PPO glass fiber reinforced)					
Coupling nut		Brass					

<sup>1)</sup> Actuators with 6 mm travel can also be used for valves with 7.5 mm travel (45 s transit time).

<sup>2)</sup> Value adjustable in TROVIS-VIEW Configuration and Operator Interface.  
Refer to EB 5824 EN for more details (also included in TROVIS-VIEW).

<sup>3)</sup> Default setting

<sup>4)</sup> The voltage must not fall below the specified voltage when a faster stroking speed or/and a 24 V supply voltage is used

<sup>5)</sup> Safety spring pulls the actuator stem into the retracted end position; valve operated over the valve spring

<sup>6)</sup> Manual override using a 4 mm Allen key after removing housing front cover, always returns to fail-safe position after release

<sup>7)</sup> Only power supply units complying to DIN VDE 0100-410 must be used.

Travel indication  
scale



Handwheel

#### NOTICE

The handwheel is used to move the actuator stem. **Only operate the handwheel when the actuator is in the de-energized state.**

In the version with digital positioner, do **not** operate the handwheel while the actuator is in service (absolute travel adjustment, see EB 5824 EN), otherwise the feedback signal will be shifted.

**Note:** The handwheel in the Type 5825 is located underneath the housing front cover.

Fig. 5 · Type 5854 Electric Actuator

#### Type 5825 with fail-safe action “Actuator stem retracts”

Place the actuator on the valve connection or the intermediate insulating piece and secure with the coupling nut (tightening torque 20 Nm).

#### Type 5825 with fail-safe action “Actuator stem extends”

1. Unfasten the front cover and place a 4 mm hex screwdriver to retract the actuator stem.
2. Retract the actuator stem by turning the screwdriver **counterclockwise only** and only until the travel final value is reached, at the maximum, which activates the bottom torque switch.

---

#### **Note!**

*Do not turn the actuator stem too far, otherwise it will be ruined.*

---

3. Hold the screwdriver in place. Secure the actuator and valve with the coupling nut (tightening torque 20 Nm). Remove screwdriver and carefully refasten the front cover.

## 5.2 Attaching the actuator to the valve

1. Turn the handwheel (Fig. 5) counterclockwise to retract the actuator stem as far as it will go.
2. Place the actuator on the valve connection or the intermediate insulating piece and secure with the coupling nut (tightening torque 20 Nm).

## 5.3 Electrical connection



### **DANGER!**

#### **Risk of electric shock!**

*When installing electric cables, you are required to observe the regulations governing electrical power plant installation according to DIN VDE 0100 as well as the regulations of your local power supply company.*

*Use a suitable power supply which guarantees that no dangerous voltages reach the device in normal operation or in case of a fault in the system or any other system parts.*

*Connect the actuator to the electrical network only after the power supply is first switched off. Make sure the power cannot be switched on unintentionally!*

*Especially when a 24 V voltage supply is used, wires with sufficiently large wire cross-sections must be used to guarantee that the permissible voltage tolerances of  $\pm 10\%$  are not exceeded!*

### Three-point stepping version

- ▶ Connect the cable as shown in Fig. 6, observing the following important instructions.

The control signals of the controller are connected to the terminals **eL** and **aL**.

- ▶ A voltage signal applied to **eL** causes the actuator stem to move upwards in the direction of action "actuator stem retracts".
- ▶ A voltage signal applied to **aL** causes the actuator stem to move downwards in the direction of action "actuator stem extends".

### Important instructions:

- ▶ Decoupling capacitors  $C_e$  in the output circuit of the connected controller may not exceed a value of 2.5 nF in order to guarantee the proper functioning of the actuator.  
When actuators are to be connected to controllers with larger interference suppression capacitors, a special version is available on request.
- ▶ Actuators operated in parallel must be connected over separate contacts to prevent the actuators hunting in the end positions due to a shared OPEN or CLOSED contact.
- ▶ Do not connect more than two current inputs in series.
- ▶ If more than two actuators are to be connected to one controller, use voltage inputs and convert current (mA) signals into voltage by using resistors ( $R_{\text{total}} = 500 \Omega$ ) connected in parallel. Use two-core cables for voltage supply, signal input and signal output. The "-" inputs can be combined.

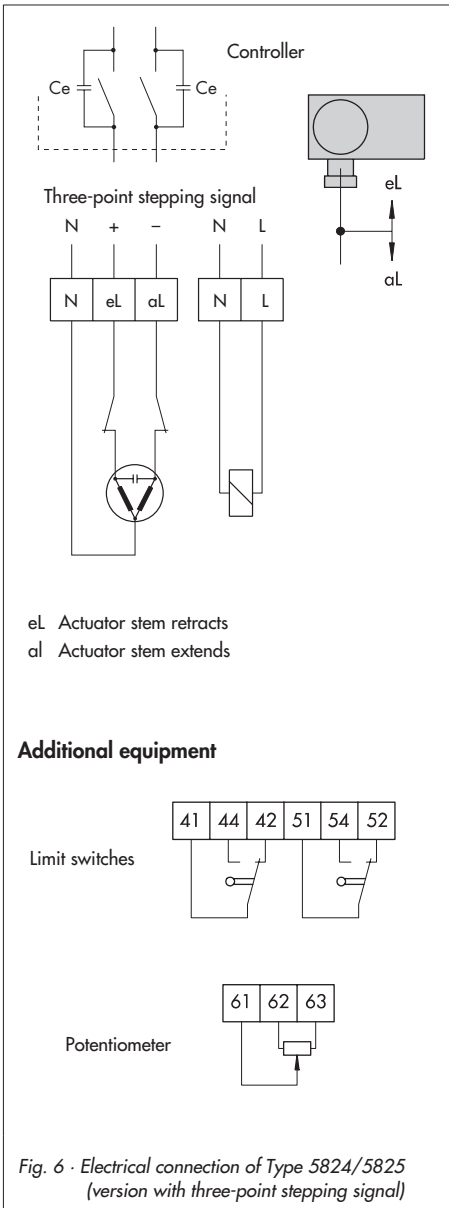

Version with digital positioner

**WARNING!**

Directly after connecting the voltage to the actuator, a zero calibration is automatically performed when the absolute travel adjustment is set (state of delivery), causing the actuator stem to move.

Do not touch the actuator stem or obstruct it to avoid risk of injury to hands or fingers.

**NOTICE**

During zero calibration, the control valve moves through a part of the travel range. As a result, do not connect the wires of the actuator while a process is running. Instead, close the shut-off valves in the plant first.

Connect the 6-wire cable according to Fig. 4.

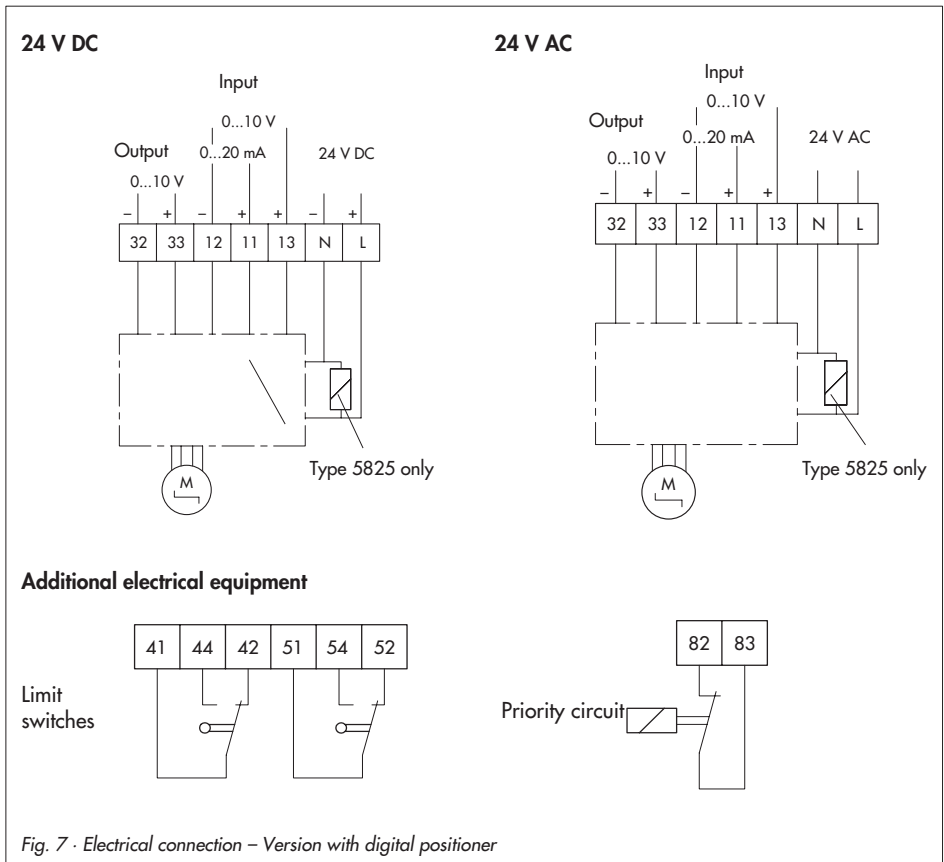

Fig. 7 · Electrical connection – Version with digital positioner

## 6 Combination with Type 2780 Pneumatic Actuator

### 6.1 Technical data for actuators

Nominal size	DN	DN 15 to 50 (G ½ to G 1)
Diaphragm area	cm <sup>2</sup>	120
Maximum supply pressure	bar	4
Fail-safe action		Reversible
Rated travel	DN 15 to 25 (G ½ to G 1)	6 mm
	DN 32 to 50	12 mm
Bench range	Type 2780-1	0.4 to 1 bar
	Type 2780-2	0.4 to 2 bar
Required supply pressure	bar	2.4
Number of actuator springs		3 <sup>1)</sup>
Leakage rate	l <sub>v</sub> /h	< 10
Loading pressure connection Type 2780-1		ISO 288/1, G ⅛; ⅙ NPT
Ambient temperature		-10 to 80 °C
<b>Materials</b>		
Actuator housing <sup>2)</sup>		Aluminum GD-ALSi12
Diaphragm		NBR
Springs <sup>2)</sup>		Spring wire C
External bolts		Chromated steel
Bushing		CW617N (CuZn40Pb)
<b>Weight</b>	Type 2780-1	2 kg
	Type 2780-2	3.2 kg

<sup>1)</sup> Six springs for bench range 0.4 to 2 bar with 12 mm travel

<sup>2)</sup> Without paint finish and surface treatment

### 6.2 Mounting the actuator onto the valve

1. Apply signal pressure to the loading pressure connection of actuator with fail-safe action "Actuator stem extends" (see section 6.3) to retract the actuator stem.
2. Place the actuator on the connection piece and secure with the coupling nut.

### 6.3 Pneumatic connection

#### Type 2780-1

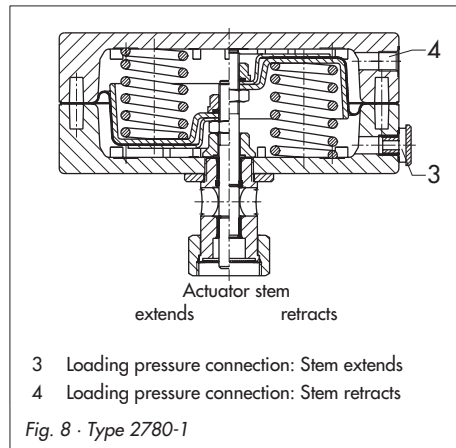

1. Connect the signal pressure to actuators with "Actuator stem extends" to loading pressure connection (3):  
When the signal pressure is reduced or upon supply air failure, the springs move the actuator stem downwards, causing the mounted valve to close.

Connect the signal pressure to actuators

with “Actuator stem retracts” to loading pressure connection (4):

When the signal pressure is reduced or upon supply air failure, the springs move the actuator stem upwards, causing the mounted valve to open.

2. Screw the vent plug in the connection which is not used.

### Type 2780-2

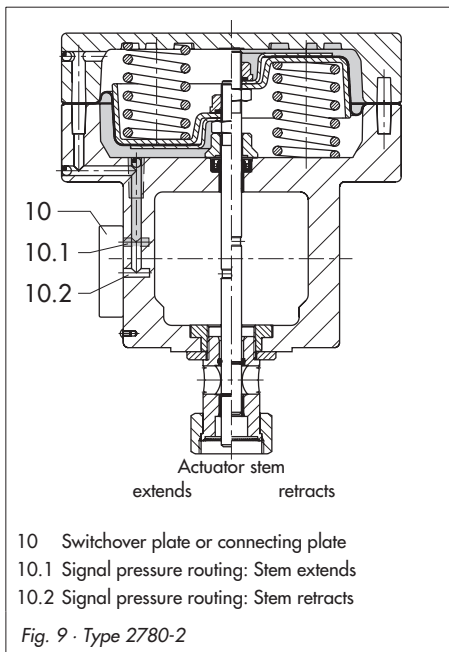

The Type 2780-2 Actuator is designed for integral attachment of a positioner. The signal pressure is routed to the diaphragm chamber by the switchover plate attached to the left or right side of the yoke. The fail-safe position required determines how the

positioner is attached and how the switchover plate is positioned.

If the actuator is operated without a positioner, a connecting plate must be used instead of the switchover plate.

## 7 Maintenance

The control valve is subject to natural wear. Depending on the conditions the valve is operated in, it needs to be checked at regular intervals.

If leakage to the atmosphere occurs, disassemble the valve and replace the damaged parts.

### WARNING!

*For maintenance work on the valve, make sure the relevant section of the pipeline is depressurized and, depending on the process medium, drained as well.*

*For high medium temperatures, allow the section of the pipeline to cool down before starting.*

*Make sure the control signal for the actuator is disconnected and the signal pressure line of a pneumatic actuator is removed.*

## 8 Dimensions in mm and weights

Nominal size	DN	15	20	25	32	40	50
Thread size	G	½	¾	1	–	–	–
Pipe	Ød	21.3	26.8	33.7	42	48	60
Thread size	R	G ¾	G 1	G 1¼	G 1¾	G 2	G 2½
Width across flats	SW	30	36	46	59	65	82
Length	L	65	70	75	100	110	130
Length with welding ends	L1	210	234	244	268	294	330
Height	H2	45.5			94		
Versions for temperatures up to 200 °C and with intermediate insulating piece		140			185		
Height H3		30			55		
Weight without actuator	approx. kg	1.4	1.8	2.3	4.0	4.4	6.8
Versions for temperatures up to 200 °C and with intermediate insulating piece		1.9	2.3	2.8	4.5	4.9	7.3
<b>Version with threaded ends (male thread)</b>							
Length	L2	129	144	159	180	196	228
Male thread	A	G ½	G ¾	G 1	G 1¼	G 1½	G 2
Weight without actuator	approx. kg	1.4	1.8	2.3	4.0	4.4	6.8
Versions for temperatures up to 200 °C and with intermediate insulating piece		1.9	2.3	2.8	4.5	4.9	7.3
<b>Version with flanges</b>							
Length	L3	130	150	160	180	200	230
Weight without actuator	approx. kg	2.5	3.4	4.1	6.9	7.7	10.7
Versions for temperatures up to 200 °C and with intermediate insulating piece		3.0	3.9	4.6	7.4	8.2	11.2
<b>Version with female thread</b>							
Length	L4	65	75	90	–		
Female thread	G	G ½	G ¾	G 1	–		
Weight without actuator	approx. kg	1.2	1.4	1.5	–		
Versions for temperatures up to 200 °C and with intermediate insulating piece		1.7	1.9	2.0	–		



Nominal size	DN	15	20	25	32	40	50
Thread size	G	½	¾	1	-	-	-
<b>Version with flanged valve body</b>							
Height	H2	45.5			94		
Length	L3	130	150	160	180	200	230
Weight without actuator	approx. kg	2.5	3.4	4.1	6.9	8.4	11.6
Versions for temperatures up to 200 °C and with intermediate insulating piece		3.0	3.9	4.6	7.4	8.9	12.1

### Weight of actuators

Actuator Type	5824	5825	5857	2780-1	2780-2
Weight without valve, approx. kg	0.75	0.75	0.7	2.0	3.2

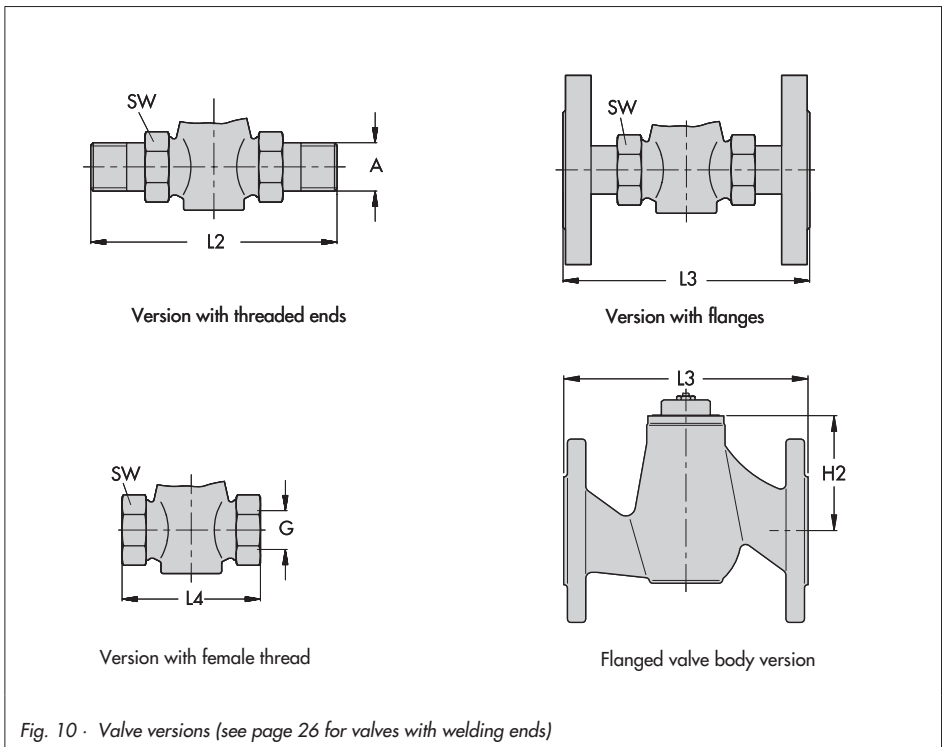
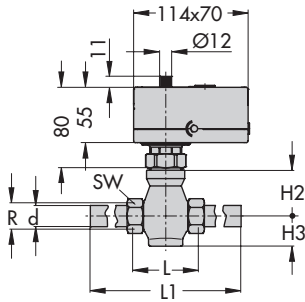
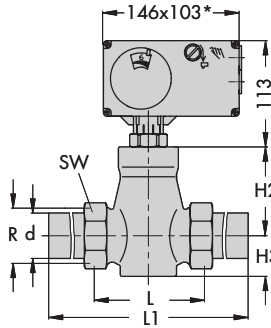

Fig. 10 · Valve versions (see page 26 for valves with welding ends)

Electric control valves



Type 3222/5857: DN 15 to 25



Type 3222/5824-xx: DN 15 to 50  
Type 3222/5825-xx: DN 15 to 50

\* Dimensions for Type 582x-x3:  
146 x 136

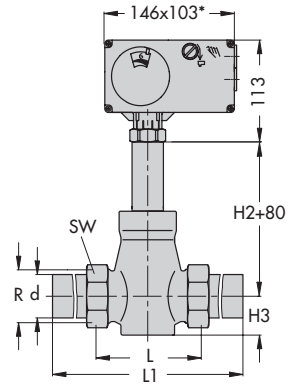

Version for water and steam  
up to 200 °C:

Type 3222/5824-xx: DN 15 to 50  
Type 3222/5825-xx: DN 15 to 50

\* Dimensions for Type 582x-x3:  
146 x 136

Pneumatic control valves

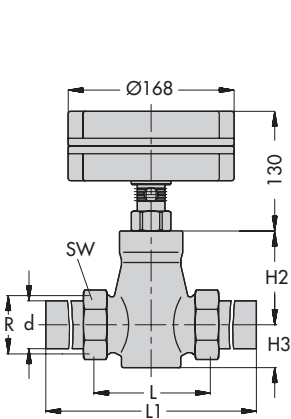

Type 3222/2780-1: DN 15 to 50

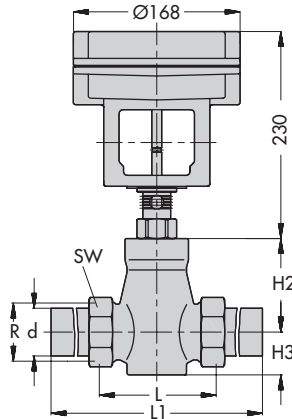

Type 3222/2780-2: DN 15 to 50

Fig. 12 · Control valve dimensions (valves with welding ends)





SAMSON AG · MESS- UND REGELTECHNIK  
Weismüllerstraße 3 · 60314 Frankfurt am Main · Germany  
Phone: +49 69 4009-0 · Fax: +49 69 4009-1507  
Internet: <http://www.samson.de>

**EB 5866 EN**

S/Z 2009-11