

Wenn nicht anderweitig angegeben, sind metrische Schiffschrauben entsprechend den HERRENKNECHT-Anweisungen nach folgender Tabelle anzusetzen.
 Schrauben-Anzugsmomente in Nm
 nach A-MB0002, A-GW002, A-FS003 und A-MT005
 Reibungskoeffizient μ ges. = 0,12

If not defined otherwise, metric screws have to be tightened in accordance with the prescriptions from HERRENKNECHT in the following table
 Screw tightening torques in Nm
 following A-MB0002, A-GW002, A-FS003 and A-MT005
 coefficient of friction μ list = 0,12

	5,8	8,8	10,9	12,9
M6	4,3	9,9	14	16,5
M8	10,5	24	34	40
M10	21	44	64	75
M12	35	75	110	130
M16	85	180	265	310
M20	165	380	520	600
M24	285	630	890	1050
M27	415	910	1300	1500

Werksmontagenacht
 Workshop assembly welding seam
 Soudure de montage d'atelier

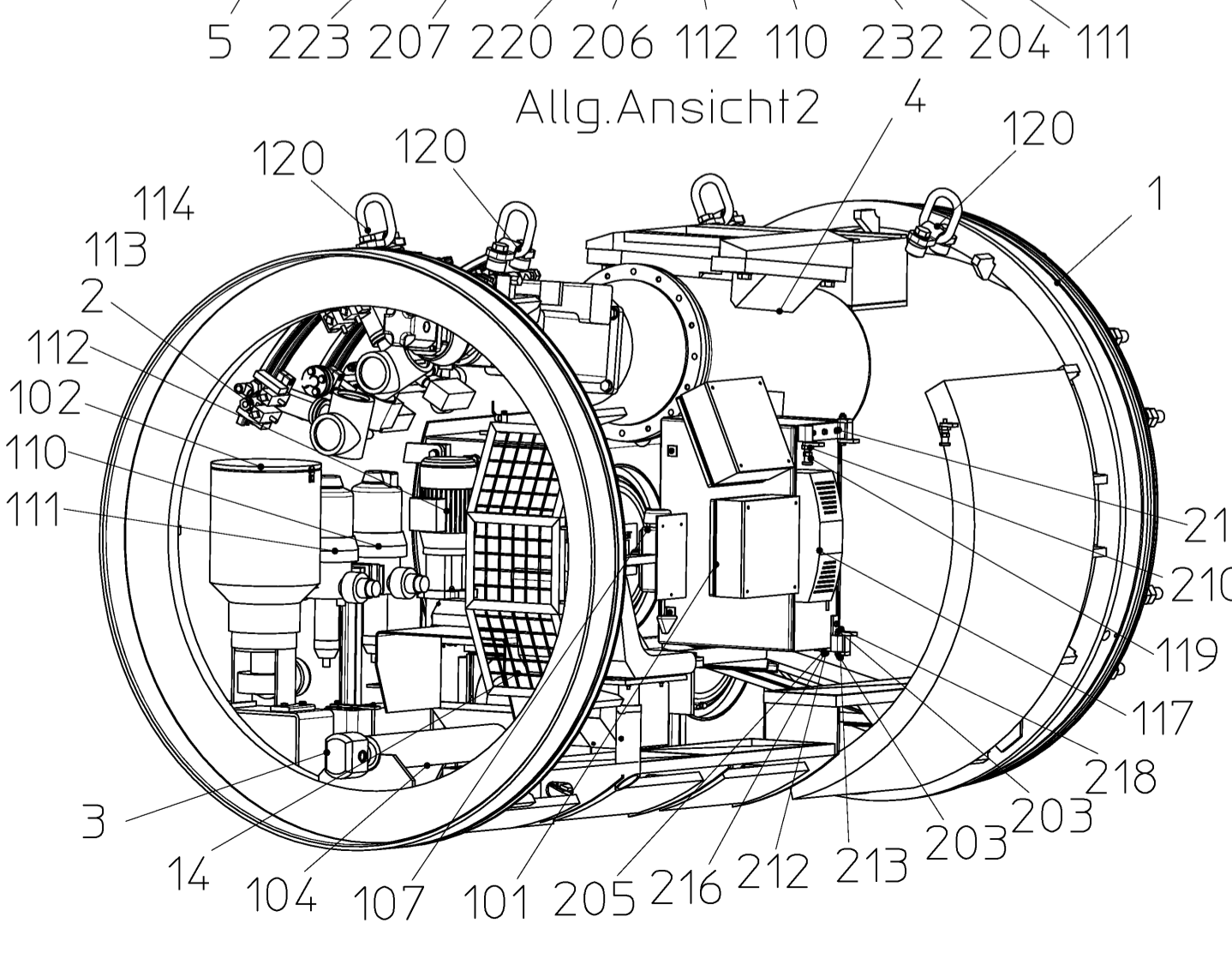
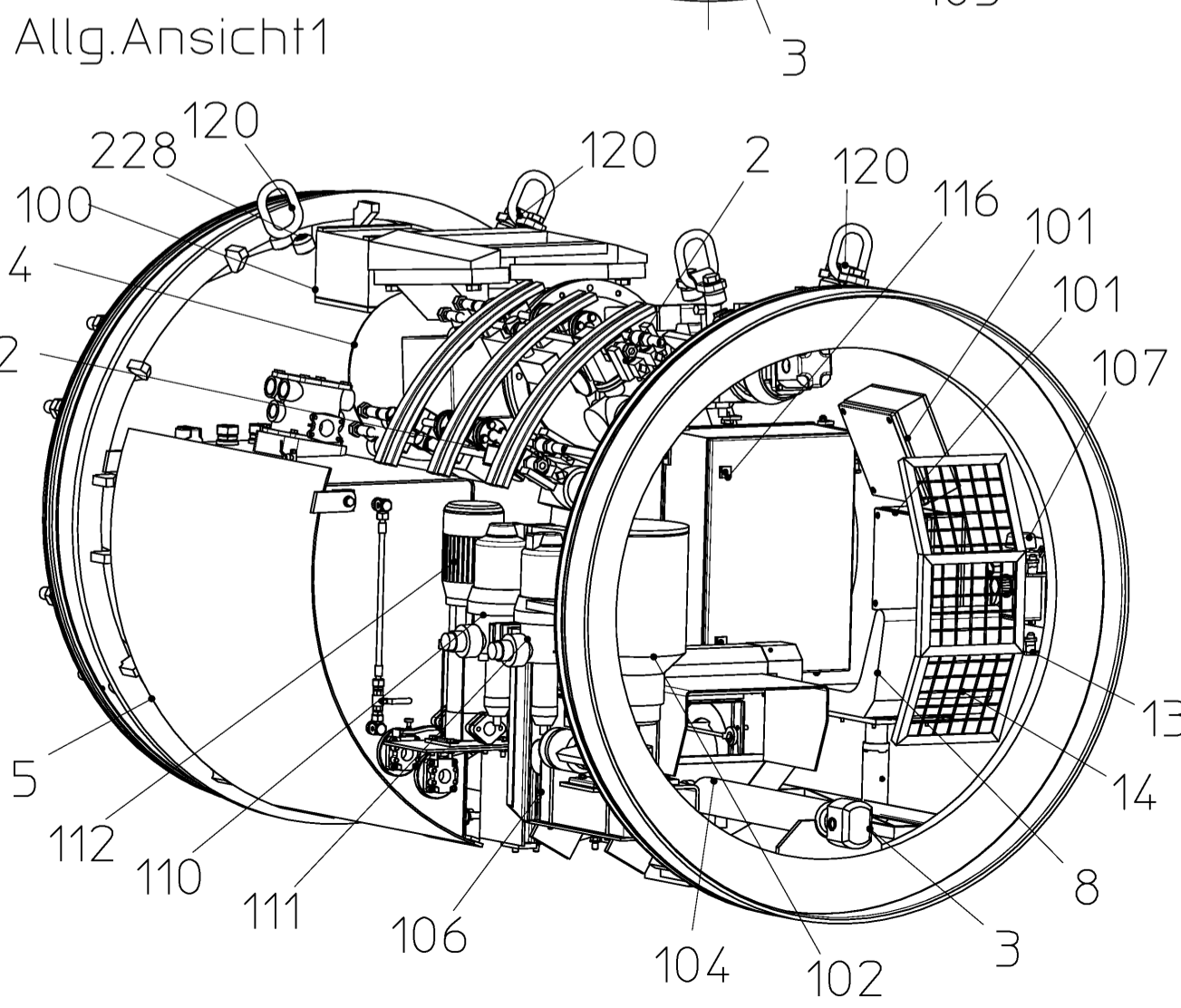

Pos. 300 PT Maschinenrohr 2 Art.Nr. 2526 8980

The reproduction, distribution and utilization of this document as well as the communication of its contents to others without express authorization is prohibited. Offenders will be held liable for the payment of damages. All rights reserved in the event of the grant of a patent, utility model or design. ISO 16016

name	MACHINE PIPE 2	drawing type	scale	general tolerances														
part number	OD1855	assembly	1:20															
drawing number	3474-01-006-00	part number	30207768	weight/kg														
		sheet nr.	1/1	7350														
		projection	surface specifications according to ISO 1302:1992															
<table border="1"> <tr> <td>A</td> <td>Pos.104 war 20001618; Pos.10 war 25603248; Pos.9 war 25600296;</td> <td>Datum</td> <td>28.11.2011</td> <td>Loh</td> <td>10.01.2012</td> <td>ManD</td> </tr> <tr> <td>Index</td> <td>Pos.8 war 30045475; Pos.15,16,17,229,230,231 hinzu</td> <td>Änderung</td> <td></td> <td></td> <td></td> <td></td> </tr> </table>					A	Pos.104 war 20001618; Pos.10 war 25603248; Pos.9 war 25600296;	Datum	28.11.2011	Loh	10.01.2012	ManD	Index	Pos.8 war 30045475; Pos.15,16,17,229,230,231 hinzu	Änderung				
A	Pos.104 war 20001618; Pos.10 war 25603248; Pos.9 war 25600296;	Datum	28.11.2011	Loh	10.01.2012	ManD												
Index	Pos.8 war 30045475; Pos.15,16,17,229,230,231 hinzu	Änderung																
Weitergabe sowie Vervielfältigung dieses Dokuments, Verwertung und Mitteilung seines Inhalts sind verboten, soweit nicht ausdrücklich gestattet. Zuwiderhandlungen verpflichten zu Schadenersatz. Alle Rechte für den Fall der Patent-, Gebrauchsmuster- oder Geschmacksmuster-Eintragung vorbehalten. ISO 16016																		
HERRENKNECHT AG Schlehenweg 2 D-77963 Schwanau Tel: 07824/302-0 Fax: 07824/3403 www.herrenknecht.de	HERRENKNECHT Tunnelvortriebstechnik	Zeichnung Zusammenstellung	Projekt M-1641M	Maschinentyp EPB1500T-03														
Bearbeitet	01.09.2011	Name	Zetting David	Oberflächen- angabe nach ISO 1302:1992														
Geprüft	27.09.2011	Name	Mannherz Daniel	Zeichnungsnummer 3474-01-006-00														
		Datum		Blatt Nr. 1/1														
		Freimaßtoleranzen		Index A														
		Projektion	1:20	Mallstab														
		Artikelnummer	30207768	Werkstoff														
		Gewicht/kg	7350	Format A2														

Baukastenstückliste

Modular parts list



Projekt M-1641
Teilenummer 30207768
MASCHINENROHR 2
Zeichnungsnr. 3474-01-006-00 A

Project M-1641
Part Number 30207768
MACHINE PIPE 2
drawing number 3474-01-006-00 A

Pos	Part number	Bezeichnung	Designation	Quantity
1	30207856	MASCHINENROHR 2	MACHINE PIPE 2	1,00 ST
2	30045287	DOSIEREINHEIT	DOSING UNIT	2,00 ST
3	30217061	STEMPEL	RAM	1,00 ST
4	30208053	MOTORPUMPENEINHEIT	MOTOR PUMP UNIT	1,00 ST
5	30207983	ÖLBEHÄLTER	OIL TANK	1,00 ST
6	30045466	SCHIENE	RAIL	1,00 ST
7	30034552	HALTEBLECH	SHEET	2,00 ST
8	30219174	FAHRERSITZ	DRIVER SEAT	1,00 ST
9	25641642	BOLZEN	BOLT	2,00 ST
10	25611154	DISTANZRING	SPACER RING	2,00 ST
11	30210449	SCHUTZBLECH	PROTECTION PLATE	1,00 ST
12	30209535	BEFESTIGUNG	MOUNTING	1,00 ST
13	30212128	HALTERUNG	FIXING DEVICE	1,00 ST
14	30208829	SCHUTZTÜR	GUARD DOOR	1,00 ST

Baukastenstückliste

Modular parts list



Projekt M-1641
Teilenummer 30207768
MASCHINENROHR 2
Zeichnungsnr. 3474-01-006-00 A

Project M-1641
Part Number 30207768
MACHINE PIPE 2
drawing number 3474-01-006-00 A

Pos	Part number	Bezeichnung	Designation	Quantity
15	30217039	BUCHSE	BUSH	2,00 ST
16	30219192	HALTERUNG	FIXING DEVICE	1,00 ST
17	30219659	POLYMERTANK	POLYMER TANK	1,00 ST
100	26601107	SCHALTSCHRANK	SWITCHGEAR CABINET	1,00 ST
101	26604695	KLEMMENKASTEN O.FLANSCHPLATTE	CONTROL CABINET	2,00 ST
102	23500569	MEHRLEITUNGSPUMPE	MULTIPLE LINE PUMP	1,00 ST
103	30115834	MASCHINENWINDE+SEILSPULVORR.	MACHINE WINCH+WIRE SPOOL DEV.	1,00 ST
104	20001162	TELESKOPZYLINDER	TELESCOPIC CYLINDER	1,00 ST
105	28100882	DICHTUNGSPROFILRING	SEAL	1,00 ST
106	23600316	PLATTENWÄRMETAUSCHER	PLATE HEAT EXCHANGER	1,00 ST
107	26900172	TELEFON NOT	EMERGENCY TELEPHONE	1,00 ST
110	29904065	FLÜSSIGDOSIERGERÄT	LIQUID DOSING UNIT	1,00 ST
111	29904064	FLÜSSIGDOSIERGERÄT	LIQUID DOSING UNIT	1,00 ST
112	23503596	KREISELPUMPENEINHEIT	CENTRIFUGAL PUMP UNIT	1,00 ST

Baukastenstückliste

Modular parts list



Projekt M-1641
Teilenummer 30207768
MASCHINENROHR 2
Zeichnungsnr. 3474-01-006-00 A

Project M-1641
Part Number 30207768
MACHINE PIPE 2
drawing number 3474-01-006-00 A

Pos	Part number	Bezeichnung	Designation	Quantity
114	24900918	SPANNSCHLOSS VERGÜTET-FVZ	SPANNER NUT	2,00 ST
116	26602715	SCHALTSCHRANK	SWITCH CABINET	1,00 ST
117	26605608	KÜHLGERÄT WANDANBAU	COOLING DEVICE WALL ATTACHMENT	1,00 ST
119	24900942	RASTBOLZEN	DETENT PIN	2,00 ST
120	29900016	ANSCHLAGPUNKT ANSCHLAGÖSE	TRANSPORTATION RING LIFTING EY	4,00 STZ
123	29501182	GITTERROST RUTSCHHEMMEND FVZ	GRATING	1,00 ST
124	29501182	GITTERROST RUTSCHHEMMEND FVZ	GRATING	1,00 ST
125	29500796	GITTERROST FVZ	GRATING	1,00 ST
126	29500397	GITTERROST FVZ	MESH PLATFORM	1,00 ST
200	24001308	GEWINDESTANGE M8-8.8-DIN976T1	THREADED ROD	0,84 M
201	23901775	SCHMIERNIPPEL	LUBRICATING NIPPLE	1,00 ST
202	24900064	SICHERUNGSRING	RETAINING RING	4,00 ST
203	24000176	SCHEIBE A10,5-140HV-DIN125	WASHER	8,00 ST
204	24000170	SCHEIBE A6,4-140HV-DIN125	WASHER	8,00 ST

Baukastenstückliste

Modular parts list



Projekt M-1641
Teilenummer 30207768
MASCHINENROHR 2
Zeichnungsnr. 3474-01-006-00 A

Project M-1641
Part Number 30207768
MACHINE PIPE 2
drawing number 3474-01-006-00 A

Pos	Part number	Bezeichnung	Designation	Quantity
205	24000174	SCHEIBE A8,4-140HV-DIN125	WASHER	18,00 ST
206	24000178	SCHEIBE A13-140HV-DIN125	WASHER	8,00 ST
207	24000182	SCHEIBE A17-140HV-DIN125	WASHER	16,00 ST
208	24000188	SCHEIBE A25-140HV-DIN125	WASHER	4,00 ST
210	24001806	SECHSKANTMUTTER M20-05-ISO4035	HEX.NUT	2,00 ST
211	24008004	SECHSKANTMUTTER GVZ M8-8-DIN985	HEX.NUT ZP	4,00 ST
212	24000103	SECHSKANTMUTTER M8-8-DIN934	HEX.NUT	11,00 ST
213	24008006	SECHSKANTMUTTER GVZ M10-8-DIN985	HEX.NUT ZP	2,00 ST
214	24000037	SECHSKANTMUTTER M12-8-DIN934	HEX.NUT	4,00 ST
215	24001274	SECHSKANTSCHRAUBE M8X35-8.8-DIN933	HEX.HEAD SCREW	3,00 ST
216	24000409	SECHSKANTSCHRAUBE M8X25-8.8-DIN933	HEX.HEAD SCREW	4,00 ST
217	24000458	SECHSKANTSCHRAUBE M8X16-8.8-DIN933	HEX.HEAD SCREW	4,00 ST
218	24002780	SECHSKANTSCHRAUBE M10X90-8.8-DIN933	HEX.HEAD SCREW	2,00 ST
220	24000718	SECHSKANTSCHRAUBE M12X50-8.8-DIN933	HEX.HEAD SCREW	4,00 ST

Baukastenstückliste

Modular parts list



Projekt M-1641
Teilenummer 30207768
MASCHINENROHR 2
Zeichnungsnr. 3474-01-006-00 A

Project M-1641
Part Number 30207768
MACHINE PIPE 2
drawing number 3474-01-006-00 A

Pos	Part number	Bezeichnung	Designation	Quantity
221	24002111	SECHSKANTSCHRAUBE GVZ M16X25-8.8-DIN933	HEX.HEAD SCREW ZP	4,00 ST
222	24000285	SECHSKANTSCHRAUBE M16X35-8.8-DIN933	HEX.HEAD SCREW	6,00 ST
223	24000292	SECHSKANTSCHRAUBE M16X45-8.8-DIN933	HEX.HEAD SCREW	4,00 ST
224	24000444	SECHSKANTSCHRAUBE M16X40-8.8-DIN933	HEX.HEAD SCREW	2,00 ST
225	24000799	SECHSKANTSCHRAUBE M24X80-8.8-DIN933	HEX.HEAD SCREW	4,00 ST
226	24002695	SECHSKANTSCHRAUBE GVZ M10X25-8.8-DIN933	HEX.HEAD SCREW ZP	4,00 ST
228	24007218	VERSCHLUSSSCHRAUBE M27X3-5.8-DIN906	PLUG SCREW	8,00 ST
229	24000194	SCHEIBE A37-140HV-DIN125	WASHER	24,00 ST
230	24004180	SECHSKANTMUTTER GVZ M36-8-DIN934	HEX.NUT ZP	24,00 ST
231	24005380	SECHSKANTSCHRAUBE M36X240-8.8-DIN933	HEX.HEAD SCREW	12,00 ST
232	24000519	ZYLINDERSCHRAUBE M6X16-8.8-DIN912	HEX.SOCKET HEAD CAP SCREW	8,00 ST
300	25268980	PT MASCHINENROHR 2	PT MACHINE PIPE 2	1,00 ST

Explanation: E=spare part, V=wearing part