

Steering Cylinders

Screw conveyor gate

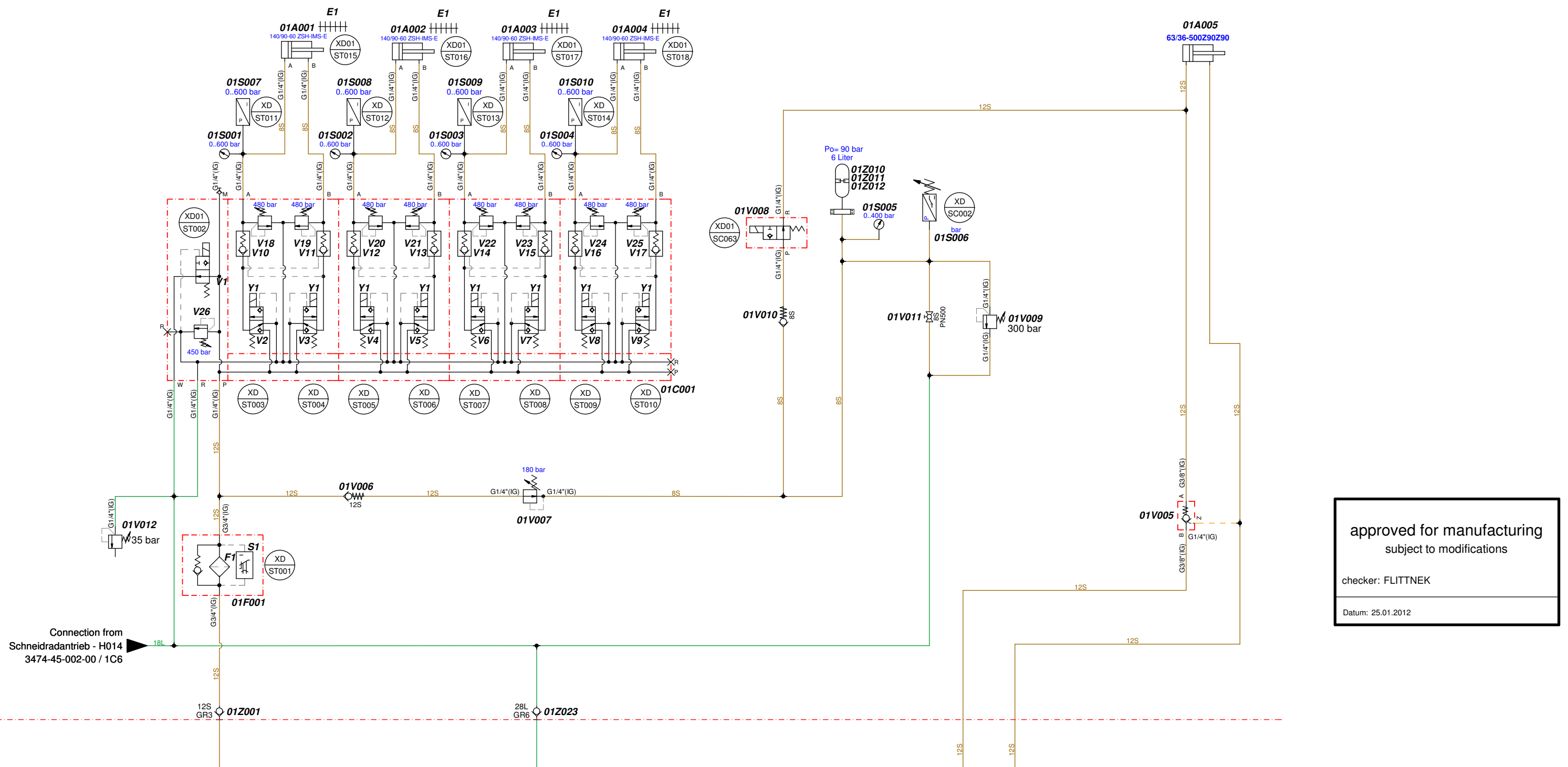

approved for manufacturing
subject to modifications

checker: FLITTNEK

Datum: 25.01.2012

C	Stand nach Montage: 01V012 neu; 01C002, 01Z008 + 01Z009 entfallen.	16.01.2012	ASSMUSM	25.01.2012	FLITTNEK
B	01S007-01S010 ergänzt (1A2-1A4)	17.11.2011	FLITTNEK	17.11.2011	ASSMUSM
A	01V008-01V011, 01S006 ergänzt	02.11.2011	FLITTNEK	02.11.2011	SCHWENGS
Index	Revision	Date	Editor	Date	Ch. by
The reproduction, distribution and utilization of this document as well as the communication of the contents to others without express authorization is prohibited. Offenders will be held liable for the payment of damages. All rights reserved in the event of a patent, utility model or design. ISO 15016					
HERRENKNECHT AG Schlehenweg 2 D-77963 Schwanau Tel.: 07824/302-0 Fax: 07824/3403 Info@Herrenknecht.de				Type of drawing	Project
				schematic	M-1641M
				Name	HYD.SCHEMA STEUERZYL/SCHIEBER
				M-1641M EPB1500TB-1860PN-02411	
Date	Name	Drawing no.	Page no.	Index	
Edited 16.01.2012	ASSMUSM	3474-45-001-00	1 / 1	C	
For check 16.01.2012	ASSMUSM	Norm	Article number	Developed from	Weight/KG
Checked 25.01.2012	FLITTNEK		25268970		Format A2

Connection from
Schneidradantrieb - H014
3474-45-002-00 / 1C6

3474-45-010-00 / 1B6
Aggregat Maschine - H048
Connection from

3474-45-010-00 / 1B7
Aggregat Maschine - H001
Connection to

3474-45-015-00 / 1B4
Hilfsbetriebe MR2 - H002
Connection from

3474-45-015-00 / 1B4
Hilfsbetriebe MR2 - H001
Connection from

Strukturstückliste

Modular parts list



Herrenknecht AG

Projekt M-1641
Artikelnummer 25268970
Zeichnungsnr. 3475-45-001-00
HYD.SCHEMA STEUERZYL/SCHIEBER M-1641M EPB1500TB-18

Project M-1641
Part Number 25268970
drawing number 3475-45-001-00
HYD.DIAGRAM STEERING/VALVE CYL

Pos	BMK	Path	Part number	Bezeichnung	Designation	drawing number	Quantity
20	01A001	1A2	20000697	STEUERZYLINDER+IMS	CONTROL CYLINDER	M01.2508-30	1,00 ST
20.1	•A1		20001165	STEUERZYLINDER	CYLINDER	577869	1,00 ST
20.1.1	••Z1		20901883	DICHTSATZ	SEALING KIT	577869/50	1,00 ST
20.2	•E1		26400864	WEGMESSSYSTEM IMS-A07	POSITION MEASURING SYSTEM	01.2451.0005	1,00 ST
21	01A002	1A3	20000697	STEUERZYLINDER+IMS	CONTROL CYLINDER	M01.2508-30	1,00 ST
21.1	•A1		20001165	STEUERZYLINDER	CYLINDER	577869	1,00 ST
21.1.1	••Z1		20901883	DICHTSATZ	SEALING KIT	577869/50	1,00 ST
21.2	•E1		26400864	WEGMESSSYSTEM IMS-A07	POSITION MEASURING SYSTEM	01.2451.0005	1,00 ST
22	01A003	1A3	20000697	STEUERZYLINDER+IMS	CONTROL CYLINDER	M01.2508-30	1,00 ST
22.1	•A1		20001165	STEUERZYLINDER	CYLINDER	577869	1,00 ST
22.1.1	••Z1		20901883	DICHTSATZ	SEALING KIT	577869/50	1,00 ST
22.2	•E1		26400864	WEGMESSSYSTEM IMS-A07	POSITION MEASURING SYSTEM	01.2451.0005	1,00 ST
23	01A004	1A4	20000697	STEUERZYLINDER+IMS	CONTROL CYLINDER	M01.2508-30	1,00 ST
23.1	•A1		20001165	STEUERZYLINDER	CYLINDER	577869	1,00 ST

Strukturstückliste

Modular parts list



Herrenknecht AG

Projekt M-1641
Artikelnummer 25268970
Zeichnungsnr. 3475-45-001-00
HYD.SCHEMA STEUERZYL/SCHIEBER M-1641M EPB1500TB-18

Project M-1641
Part Number 25268970
drawing number 3475-45-001-00
HYD.DIAGRAM STEERING/VALVE CYL

Pos	BMK	Path	Part number	Bezeichnung	Designation	drawing number	Quantity
23.1.1	••Z1		20901883	DICHTSATZ	SEALING KIT	577869/50	1,00 ST
23.2	•E1		26400864	WEGMESSSYSTEM IMS-A07	POSITION MEASURING SYSTEM	01.2451.0005	1,00 ST
24	01A005	1A7	20000113	HYDRAULIKZYLINDER	HYDRAULIC CYLINDER	099-00-034-00	1,00 ST
24.1	•Z1		20100044	DICHTSATZ	SEALING KIT	099-00-034-00	1,00 ST
6	01C001	1C2	27200905	HYDRAULIKBLOCK	HYDRAULIC BLOCK	89002-4	1,00 ST
6.1			27100308	WEGESITZVENTIL	DIRECTIONAL CONTROL VALVE		1,00 ST
6.2			27100311	WEGESITZVENTIL	DIRECTIONAL CONTROL VALVE		8,00 ST
6.3			27100312	RÜCKSCHLAGVENTIL	CHECK VALVE		8,00 ST
6.4			27100286	DRUCKVENTIL	PRESSURE VALVE		8,00 ST
6.5			27101069	DRUCKVENTIL OHNE EINSTELLUNG	PRESSURE VALVE WITHOUT ADJUSTM		1,00 ST
11	01F001	1D2	27000994	HOCHDRUCKFILTER	HIGH PRESSURE FILTER		1,00 ST
11.1			27000995	FILTERLEERGEHÄUSE	HOUSING		1,00 ST
11.2			27000996	FILTERELEMENT	FILTER ELEMENT		1,00 ST
11.3			27400009	DIFFERENZDRUCKSCHALTER M	DIFFERENTIAL PRESSURE SWITCH		1,00 ST

Strukturstückliste

Modular parts list



Herrenknecht AG

Projekt M-1641
Artikelnummer 25268970
Zeichnungsnr. 3475-45-001-00
HYD.SCHEMA STEUERZYL/SCHIEBER M-1641M EPB1500TB-18

Project M-1641
Part Number 25268970
drawing number 3475-45-001-00
HYD.DIAGRAM STEERING/VALVE CYL

Pos	BMK	Path	Part number	Bezeichnung	Designation	drawing number	Quantity
11.3.1	••D1		28001426	O-RING	O-RING		1,00 ST
11.3.2	••D2		28000623	O-RING	O-RING		1,00 ST
12	01S001	1B2	27500137	MANOMETER TYP213.53	PRESSURE GAUGE 0-600BAR		1,00 ST
12.1	•Z1		27902775	BÜGEL FÜR MANOMETER NG63	BRACKET		1,00 ST
13	01S002	1B2	27500137	MANOMETER TYP213.53	PRESSURE GAUGE 0-600BAR		1,00 ST
13.1	•Z1		27902775	BÜGEL FÜR MANOMETER NG63	BRACKET		1,00 ST
34	01S007	1B2	27501963	DRUCKMESSUMFORMER	PRESSURE TRANSDUCER		1,00 ST
35	01S008	1B2	27501963	DRUCKMESSUMFORMER	PRESSURE TRANSDUCER		1,00 ST
14	01S003	1B3	27500137	MANOMETER TYP213.53	PRESSURE GAUGE 0-600BAR		1,00 ST
14.1	•Z1		27902775	BÜGEL FÜR MANOMETER NG63	BRACKET		1,00 ST
15	01S004	1B3	27500137	MANOMETER TYP213.53	PRESSURE GAUGE 0-600BAR		1,00 ST
15.1	•Z1		27902775	BÜGEL FÜR MANOMETER NG63	BRACKET		1,00 ST
36	01S009	1B3	27501963	DRUCKMESSUMFORMER	PRESSURE TRANSDUCER		1,00 ST
16	01S005	1B5	27500017	MANOMETER TYP213.53	PRESSURE GAUGE 0-400BAR		1,00 ST

Strukturstückliste

Modular parts list



Herrenknecht AG

Projekt M-1641
Artikelnummer 25268970
Zeichnungsnr. 3475-45-001-00
 HYD.SCHEMA STEUERZYL/SCHIEBER M-1641M EPB1500TB-18

Project M-1641
Part Number 25268970
drawing number 3475-45-001-00
 HYD.DIAGRAM STEERING/VALVE CYL

Pos	BMK	Path	Part number	Bezeichnung	Designation	drawing number	Quantity
16.1	•Z1		27902775	BÜGEL FÜR MANOMETER NG63	BRACKET		1,00 ST
28	01S006	1B5	27103997	DRUCKSCHALTER	PRESSURE SWITCH	R901102722	1,00 ST
37	01S010	1B4	27501963	DRUCKMESSUMFORMER	PRESSURE TRANSDUCER		1,00 ST
25	01V008	1B4	27105071	WEGESITZVENTIL	VALVE	7000 1810-00	1,00 ST
27	01V009	1C6	27100397	DRUCKBEGRENZUNGSVENTIL	VALVE	7700 0001-00	1,00 ST
9	01V006	1D2	27103834	RÜCKSCHLAGVENTIL	NON-RETURN VALVE		1,00 ST
10	01V007	1D3	27102954	DRUCKREGELVENTIL	PRESSURE CONTROL VALVE		1,00 ST
8	01V005	1D7	27100440	RÜCKSCHLAGVENTIL	CHECK VALVE		1,00 ST
32	01V010	1C5	27103829	RÜCKSCHLAGVENTIL	NON RETURN VALVE		1,00 ST
33	01V011	1C5	27600137	BLOCKKUGELHAHN DN4	BLOCK BALL VALVE		1,00 ST
38	01V012	1D1	27101319	DRUCKBEGRENZUNGSVENTIL	PRESSURE CONTROL VALVE	7700 0002-00	1,00 ST
1	01Z001	1E2	27402271	SCHRAUBKUPPLUNG MUFFE	SCREW COUPLING SOCKET		1,00 ST
17	01Z010	1B5	27901592	BLASENSPEICHER	BUBBLE MEMORY		1,00 ST
18	01Z011	1B5	27901309	SCHELLE	CLAMP	445043	1,00 ST

Strukturstückliste

Modular parts list



Herrenknecht AG

Projekt M-1641
Artikelnummer 25268970
Zeichnungsnr. 3475-45-001-00
HYD.SCHEMA STEUERZYL/SCHIEBER M-1641M EPB1500TB-18

Project M-1641
Part Number 25268970
drawing number 3475-45-001-00
HYD.DIAGRAM STEERING/VALVE CYL

Pos	BMK	Path	Part number	Bezeichnung	Designation	drawing number	Quantity
19	01Z012	1B5	27900221	KONSOLE MIT GUMMISTÜTZRING	BRACKET PIN		1,00 ST
4	01Z023	1E3	27400120	SCHRAUBKUPPLUNG STECKER	SCREW COUPLING PLUG		1,00 ST