

+HKMM2.03
machine can 2

+HKMM2.02
machine can 1

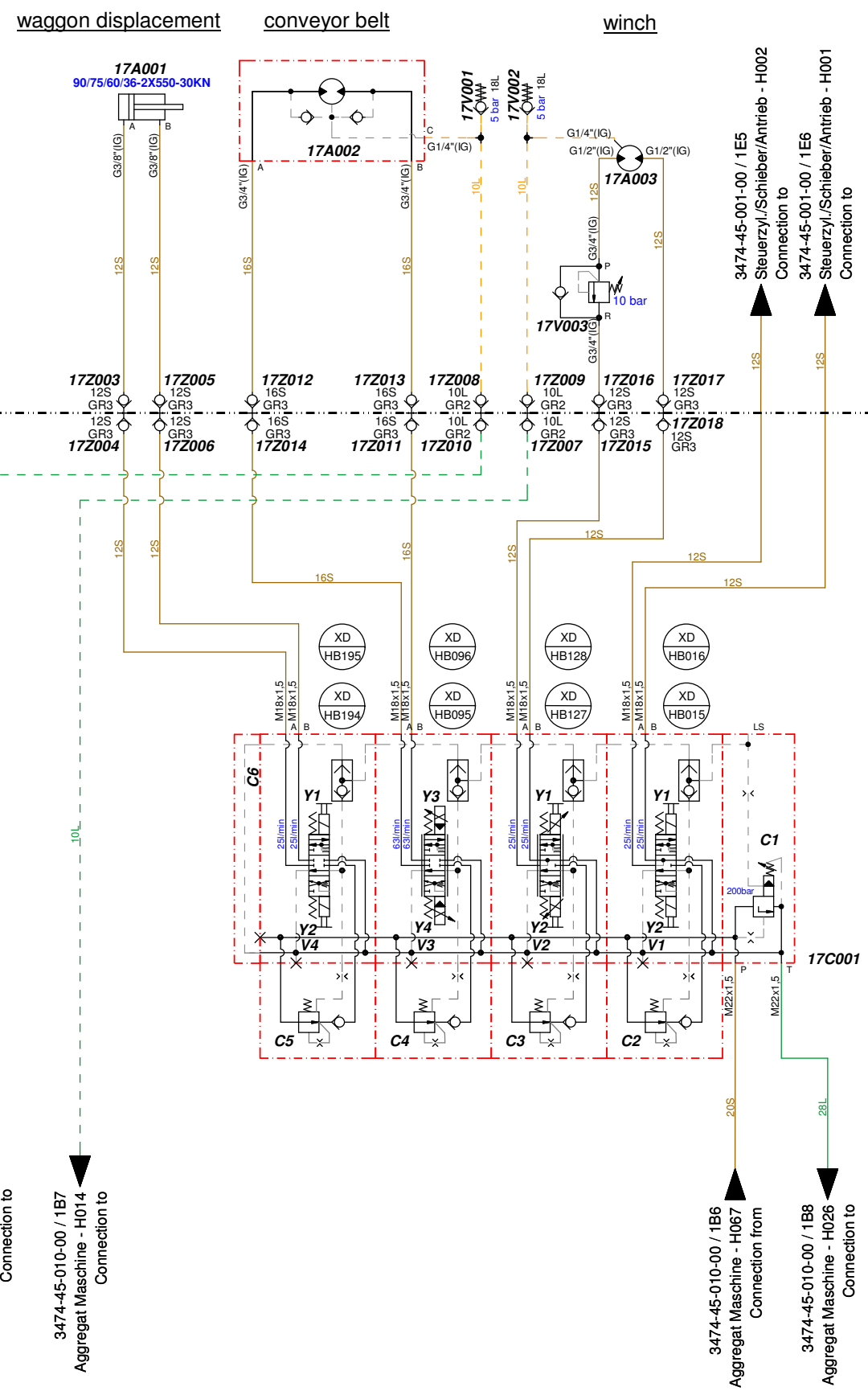

approved for manufacturing
subject to modifications

checker: FLITTNEK

Datum: 25.01.2012

A		17C001 jetzt in MR1, 17V003, 17Z015 - 17Z018 neu, 17Z001 + 17Z002 entfallen		17.01.2012	ASSMUSM	25.01.2012	FLITTNEK
		Erste Prüfung		07.09.2011	ASSMUSM	13.09.2011	HEIZMANN
Index	Revision			Date	Editor	Date	Ch. by
The reproduction, distribution and utilization of this document as well as the communication of the contents to others without express authorization is prohibited. Offenders will be held liable for the payment of damages. All rights reserved in the event of a patent, utility model or design. ISO 16016							
HERRENKNECHT AG Schlehenweg 2 D-77963 Schwanau Tel.: 07824/302-0 Fax: 07824/3403 Info@Herrenknecht.de		 Tunnelvortriebstechnik		Type of drawing schematic	Project M-1641M	Material	
				Name HYDR.SCHEMA HILFSBETRIEBE MR M-1641M EPB1500TB-1860PN-02411			
Date		Name		Drawing no.		Page no.	
Edited 17.01.2012		ASSMUSM		3474-45-015-00		1 / 1	
For check 23.01.2012		ASSMUSM				Index A	
Checked 25.01.2012		FLITTNEK		Norm	Article number 25268974	Developed from	Weight/KG
						Format A2	

Strukturstückliste

Modular parts list



Herrenknecht AG

Projekt M-1641
Artikelnummer 25268974
Zeichnungsnr. 3475-45-015-00
 HYDR.SCHEMA HILFSBETRIEBE MR M-1641M EPB1500TB-186

Project M-1641
Part Number 25268974
drawing number 3475-45-015-00
 HYDR.DIAGRAM AUXILIARY HYDR.MR

Pos	BMK	Path	Part number	Bezeichnung	Designation	drawing number	Quantity
2021	17A001	1B2	20001162	TELESKOPZYLINDER	TELESCOPIC CYLINDER	577978	1,00 ST
2021.1	•Z1		28800274	DICHTSATZ	SEALING KIT	832689/50	1,00 ST
2021.2	•Z2		20100868	DICHTSATZ EMB	SEALING KIT EMB	577978/51	1,00 ST
2022	17A002	1B2	23100034	HYDRAULIKMOTOR	HYDRAULIC MOTOR		1,00 ST
2023	17A003	1B4	23100040	HYDRAULIKMOTOR	HYDRAULIC MOTOR		1,00 ST
2023.1	•D1		23910030	DICHTSATZ	SEALING KIT		1,00 ST
1018	17C001	1E4	27204210	STUEBERBLOCK 4-FACH L.8S	CONTROL BLOCK FOURFOLD L.8S		1,00 ST
1018.1	•C1		27102588	EINGANGSPLATTE	VALVE		1,00 ST
1018.3	•C2-C5		27102621	UNTERBAU-DRUCKWAAGE L.8S	SUPPORT FRAME - PRESSURE BALAN		4,00 ST
1018.7	•C6		27102574	ABSCHLUSSPLATTE	CLOSING PLATE		1,00 ST
1018.2	•V1		27102587	WEGEVENTIL 4/3	WAY VALVE		1,00 ST
1018.2.1			27201877	MAGNET S/W 24V FÜR L.8S	MAGNET		2,00 ST
1018.4	•V2		27103814	WEGEVENTIL-PROP 4/3	VALVE		1,00 ST
1018.4.1			27902136	PROPORTIONALMAGNET FÜR LC8S	MAGNET		2,00 ST

Strukturstückliste

Modular parts list



Herrenknecht AG

Projekt M-1641
Artikelnummer 25268974
Zeichnungsnr. 3475-45-015-00
 HYDR.SCHEMA HILFSBETRIEBE MR M-1641M EPB1500TB-186

Project M-1641
Part Number 25268974
drawing number 3475-45-015-00
 HYDR.DIAGRAM AUXILIARY HYDR.MR

Pos	BMK	Path	Part number	Bezeichnung	Designation	drawing number	Quantity
1018.5	•V3		27105828	WEGEVENTIL-PROP 4/3	VALVE		1,00 ST
1018.5.1	••Y3-Y4		27900686	PROPORTIONALMAGNET FÜR LP8S	PROPORTIONAL SOLENOID FOR LP8S		2,00 ST
1018.6	•V4		27106429	WEGEVENTIL 4/3	DIRECTIONAL VALVE 4/3		1,00 ST
1018.6.1	••Y1-Y2		27902340	ELEKTROMAGNET S/W 24V FÜR L.8S	MAGNET		2,00 ST
1018.8	•Z1-Z3		27903015	DICHTMUTTER	SEALING NUT		3,00 ST
1018.9	•Z4-Z6		27904077	SCHAFTSCHRAUBE	SHAFT SCREW	100-1-400756-07	3,00 ST
1018.10	•Z7-Z14		26905884	STECKER	PLUG		8,00 ST
2019	17V001	1A3	27103845	RÜCKSCHLAGVENTIL	VALVE		1,00 ST
2020	17V002	1A3	27103845	RÜCKSCHLAGVENTIL	VALVE		1,00 ST
2024	17V003	1B4	27100266	DRUCKVENTIL	VALVE		1,00 ST
2003	17Z003	1B2	27402271	SCHRAUBKUPPLUNG MUFFE	SCREW COUPLING SOCKET		1,00 ST
2005	17Z005	1B2	27402272	SCHRAUBKUPPLUNG STECKER	SCREW COUPLING PLUG		1,00 ST
2008	17Z008	1B3	27401029	SCHRAUBKUPPLUNG STECKER	SCREW COUPLING PLUG		1,00 ST
2009	17Z009	1B3	27401028	SCHRAUBKUPPLUNG MUFFE	SCREW COUPLING SOCKET		1,00 ST

Strukturstückliste

Modular parts list



Herrenknecht AG

Projekt M-1641
Artikelnummer 25268974
Zeichnungsnr. 3475-45-015-00
 HYDR.SCHEMA HILFSBETRIEBE MR M-1641M EPB1500TB-186

Project M-1641
Part Number 25268974
drawing number 3475-45-015-00
 HYDR.DIAGRAM AUXILIARY HYDR.MR

Pos	BMK	Path	Part number	Bezeichnung	Designation	drawing number	Quantity
1004	17Z004	1C2	27402272	SCHRAUBKUPPLUNG STECKER	SCREW COUPLING PLUG		1,00 ST
1006	17Z006	1C2	27402271	SCHRAUBKUPPLUNG MUFFE	SCREW COUPLING SOCKET		1,00 ST
1007	17Z007	1C3	27401029	SCHRAUBKUPPLUNG STECKER	SCREW COUPLING PLUG		1,00 ST
2012	17Z012	1B2	27402149	SCHRAUBKUPPLUNG STECKER	SCREW COUPLING PLUG		1,00 ST
2013	17Z013	1B3	27402148	SCHRAUBKUPPLUNG MUFFE	SCREW COUPLING SOCKET		1,00 ST
2026	17Z016	1B4	27402271	SCHRAUBKUPPLUNG MUFFE	SCREW COUPLING SOCKET		1,00 ST
2027	17Z017	1B4	27402272	SCHRAUBKUPPLUNG STECKER	SCREW COUPLING PLUG		1,00 ST
1014	17Z014	1C2	27402148	SCHRAUBKUPPLUNG MUFFE	SCREW COUPLING SOCKET		1,00 ST
1010	17Z010	1C3	27401028	SCHRAUBKUPPLUNG MUFFE	SCREW COUPLING SOCKET		1,00 ST
1011	17Z011	1C3	27402149	SCHRAUBKUPPLUNG STECKER	SCREW COUPLING PLUG		1,00 ST
1025	17Z015	1C4	27402272	SCHRAUBKUPPLUNG STECKER	SCREW COUPLING PLUG		1,00 ST
1028	17Z018	1C4	27402271	SCHRAUBKUPPLUNG MUFFE	SCREW COUPLING SOCKET		1,00 ST