

VTR
DOD

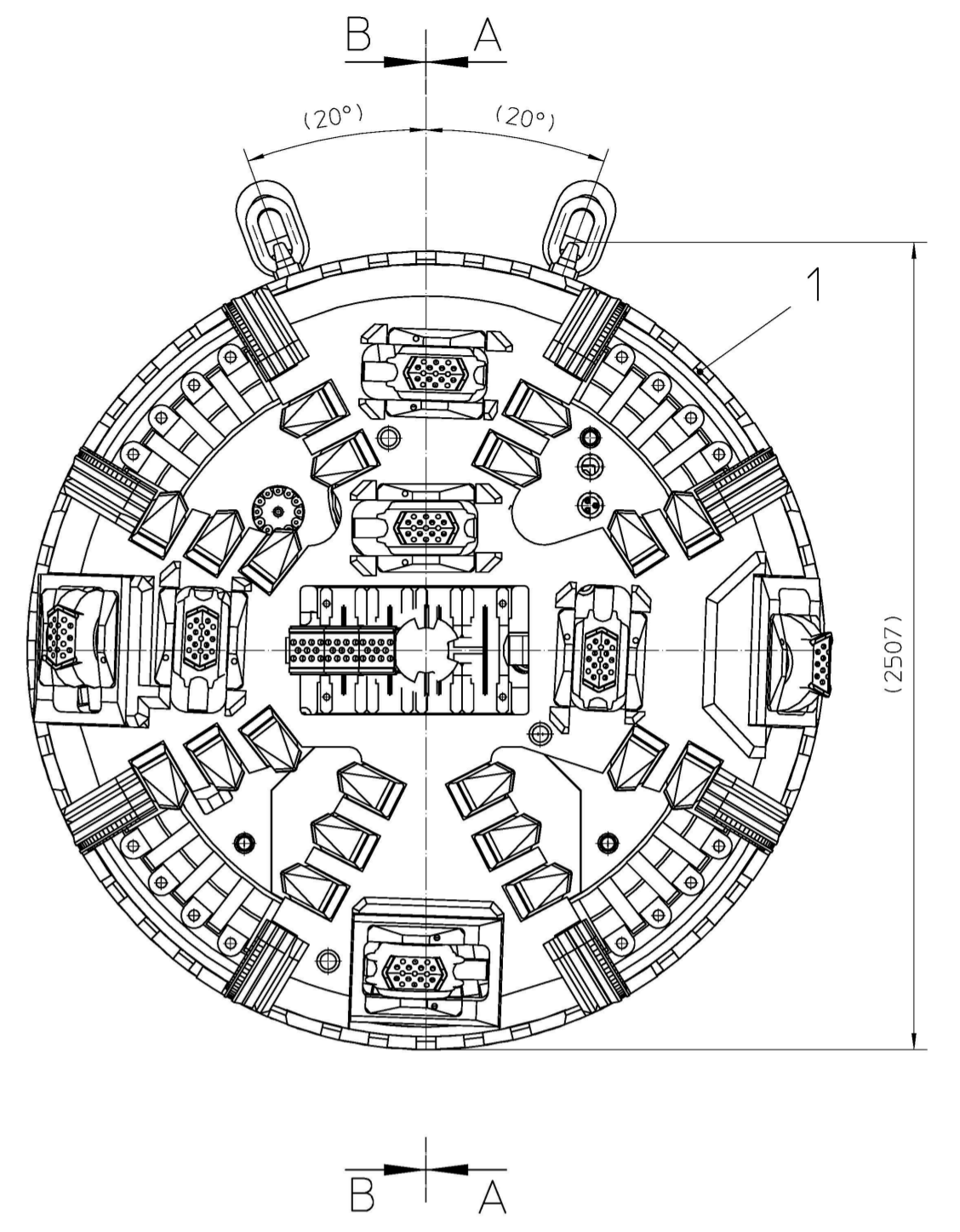

B-B

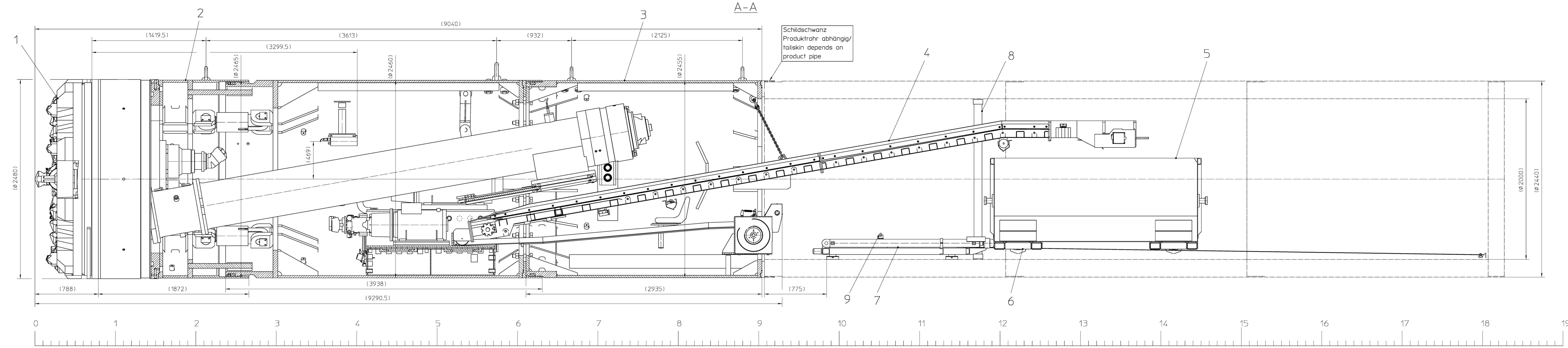
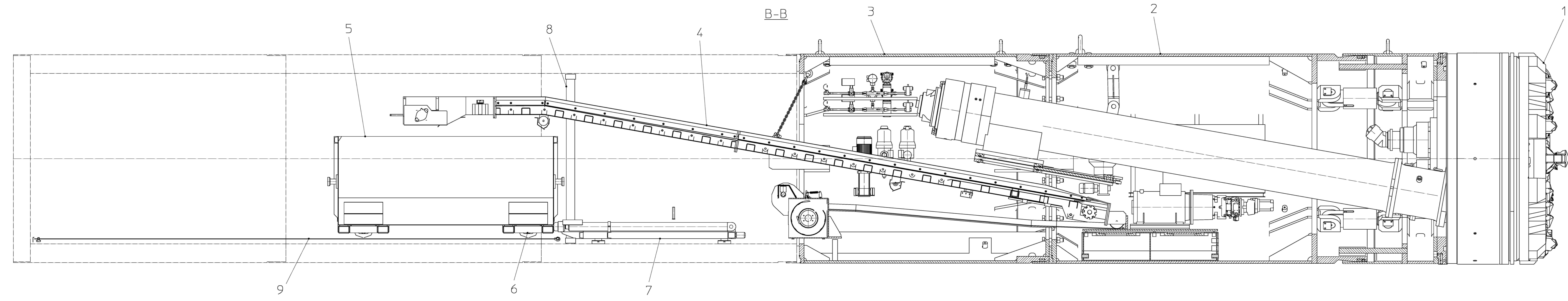

VTR
DOD

VTR=Vortriebsrichtung
DOD=direction of drive

Pos.300 | PT VORTRIEBSANLAGE/PT tunnelling system | Art.Nr.: 40619979

Revision		Change		Date	Drawn	Date	Released
The reproduction, distribution and utilization of this document as well as the communication of its contents to others without express authorization is prohibited. Offenders will be held liable for the payment of damages. All rights reserved in the event of the grant of a patent, utility model or design. ISO 18018							
Edges of undefined shape		ISO 13715:2003		Drawing type		Assembly	
Geometrical product specification		(GPS) EN ISO 1101:2013		Project		M-722M	
Surface specifications according to		EN ISO 1302:1992		Machine type		EPB2000T-01	
 www.herrknecch.com				TUNNELLING SYSTEM VORTRIEBSANLAGE DA2480		Sheet Revision Format 1/1 - A2S2	
Date	Name	Drawing number		Scale		Material	
20.07.2022	Schrötlin, Viktoria	1187-01-000-00		1:20		40620722	
Released	21.07.2022	Mannherz, Daniel		Weight/Kg		64122	

Baukastenstückliste modular BOM



Projekt
Material 40620722
Bezeichnung 1 VORTRIEBSANLAGE

Zchnng.Nr/ver 1187-01-000-00 / -
Gewicht 64.122 KG
Werk 1000

project
material 40620722
description 1 TUNNELLING SYSTEM

draw.No/ver 1187-01-000-00 / -
weight 64.122 KG
plant

Pos.	Typ type	Material	Menge qty	Bezeichnung 1 / Bezeichnung 2	description 1 / description 2	Zchnng.Nr/ver/Bpf draw.No/ver	Gewicht weight
1	L	30027592	1,000 ST	MISCHBODENKOPF	MIXED CUTTING HEAD	1187-01-012-00/A	8.000,00 KG
2	L	30027594	1,000 ST	VORTRIEBSMASCHINE	TUNNELLING MACHINE	1187-01-002-00/A	43.113,00 KG
3	L	30027595	1,000 ST	MASCHINENROHR 2	MACHINE PIPE 2	1187-01-006-00/D	10.234,00 KG
4	L	30060543	1,000 ST	FÖRDERBAND	BELT CONVEYOR		1.025,00 KG
5	L	30062303	1,000 ST	FÖRDERKÜBEL	SKIP	098-00-094-01/B	688,00 KG
6	L	30062123	1,000 ST	UNTERWAGEN	UNDERCARRIAGE	098-00-094-02/-	426,00 KG
7	L	30231922	1,000 ST	VERSCHIEBEEINHEIT	DISPLACEMENT UNIT		195,00 KG
8	L	30007410	1,000 ST	SPANNRING	TENSIONING RING		55,00 KG
9	L	40630581	1,000 ST	RÜCKZUGSVORRICHTUNG	RETRACTION DEVICE	1187-08-000-92/-	14,00 KG
300	L	40619979	1,000 ST	PT VORTRIEBSANLAGE	PT TUNNELLING SYSTEM		400,82 KG