

Gehäuse 12"

housing 12"

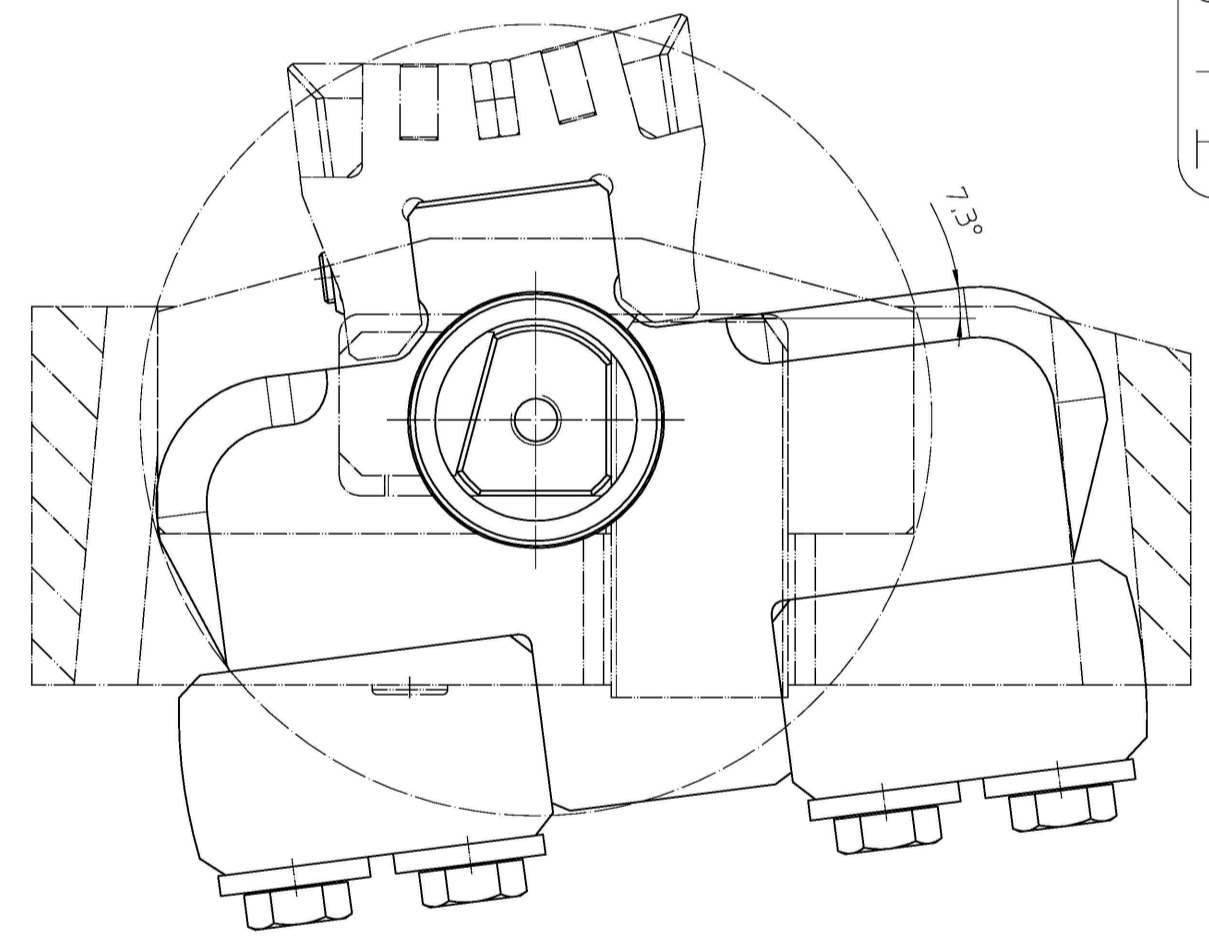
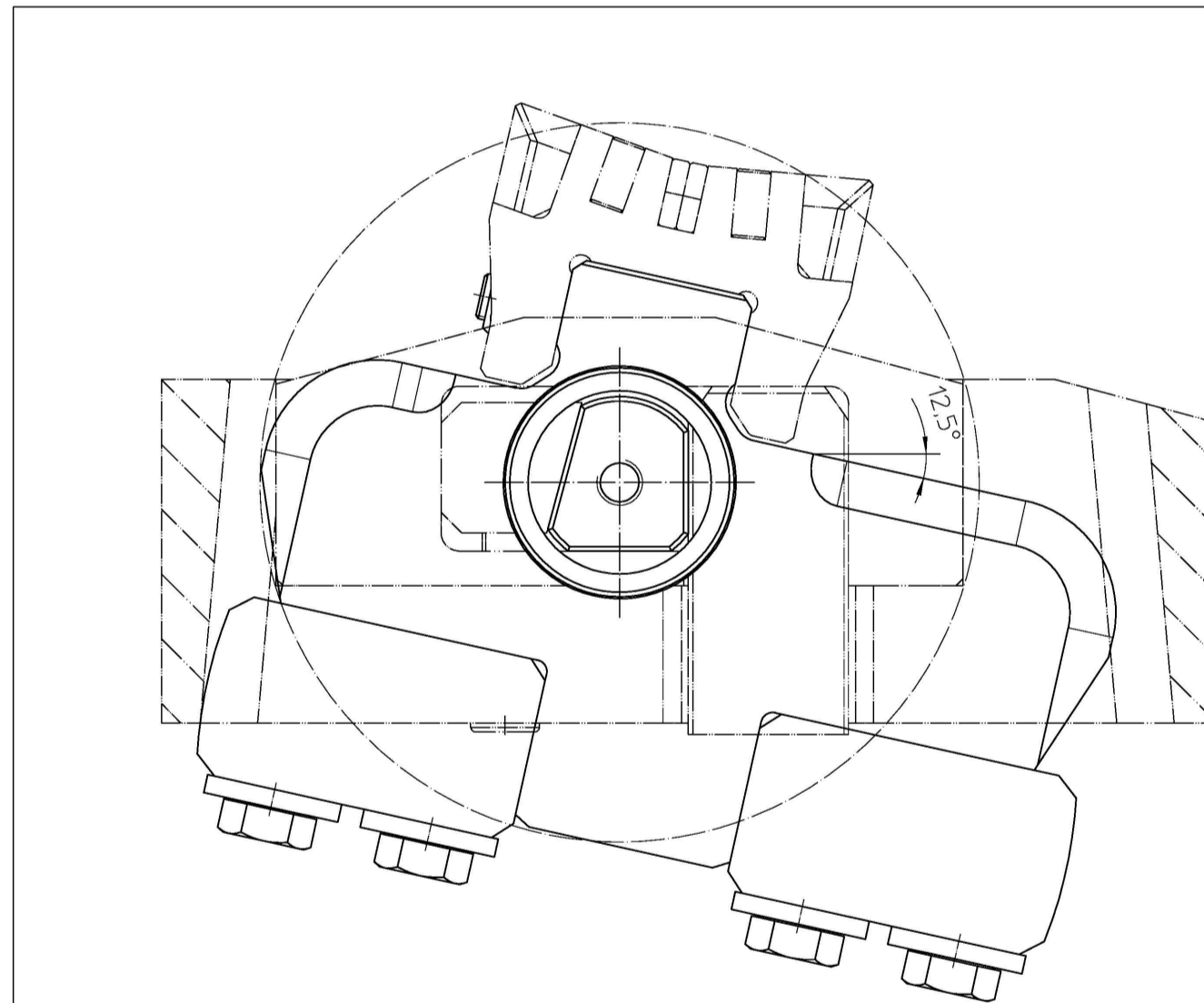
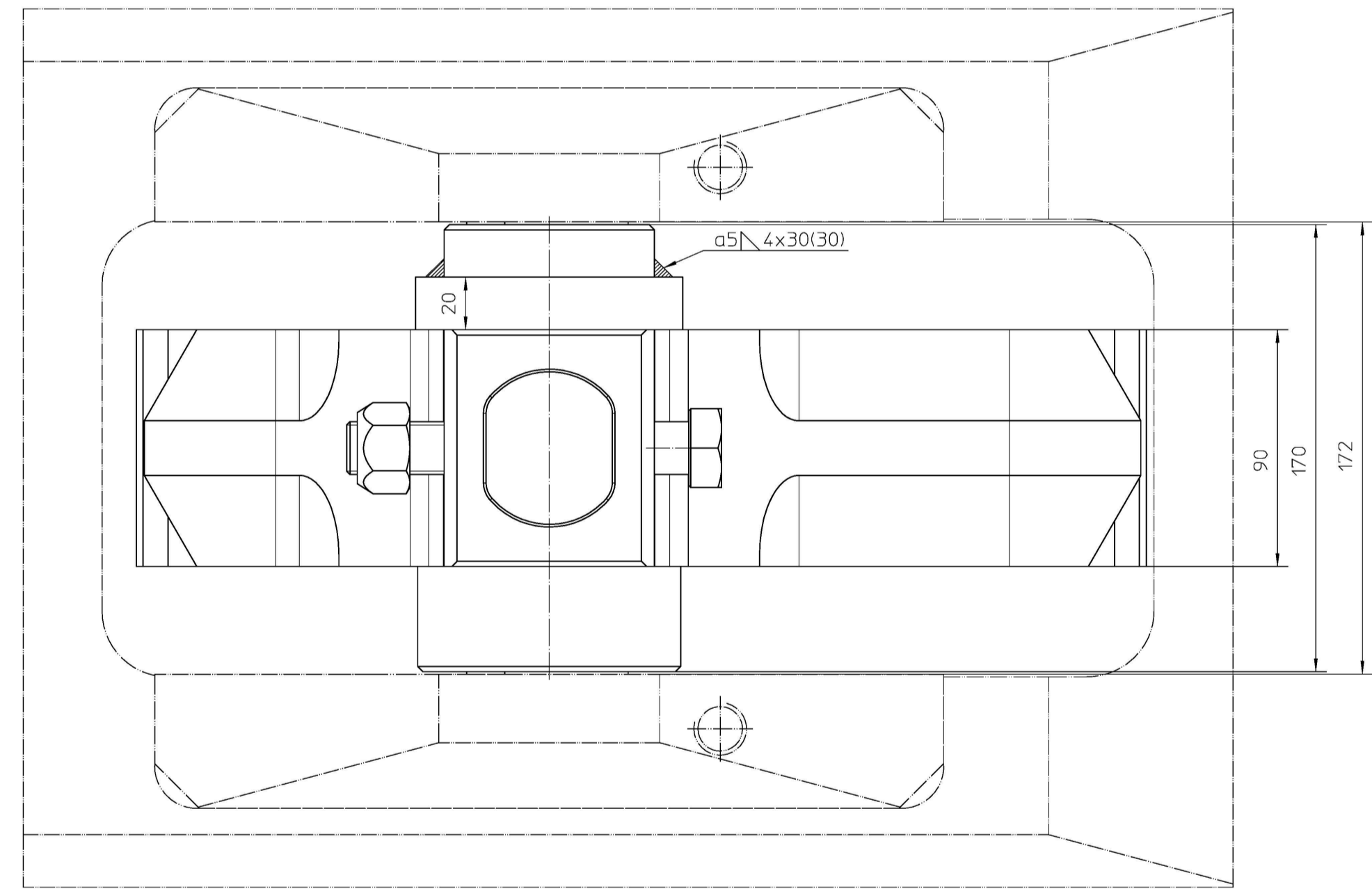

Gehäuse 13"

housing 13"

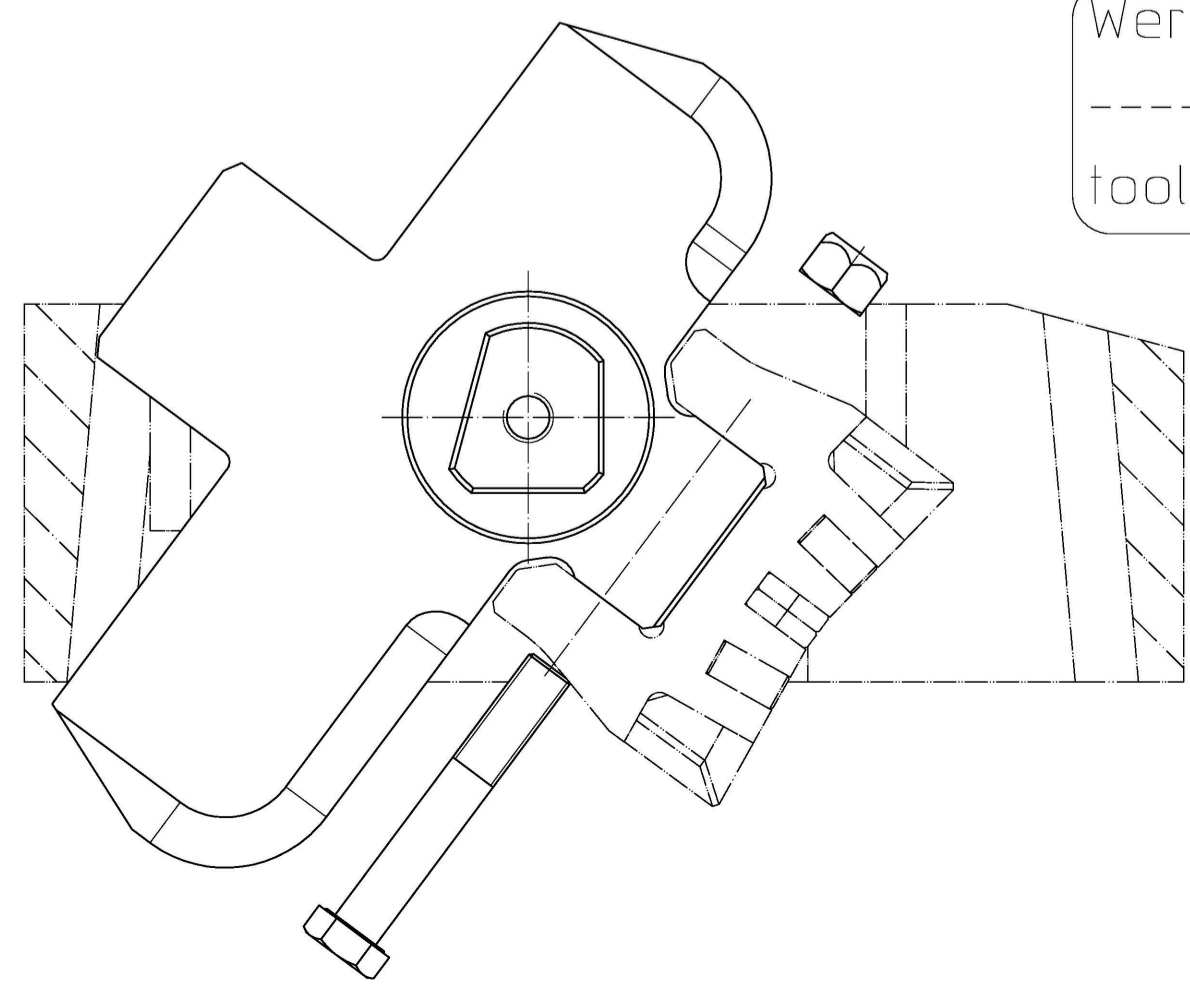

Werkzeugwechsel

tool changing

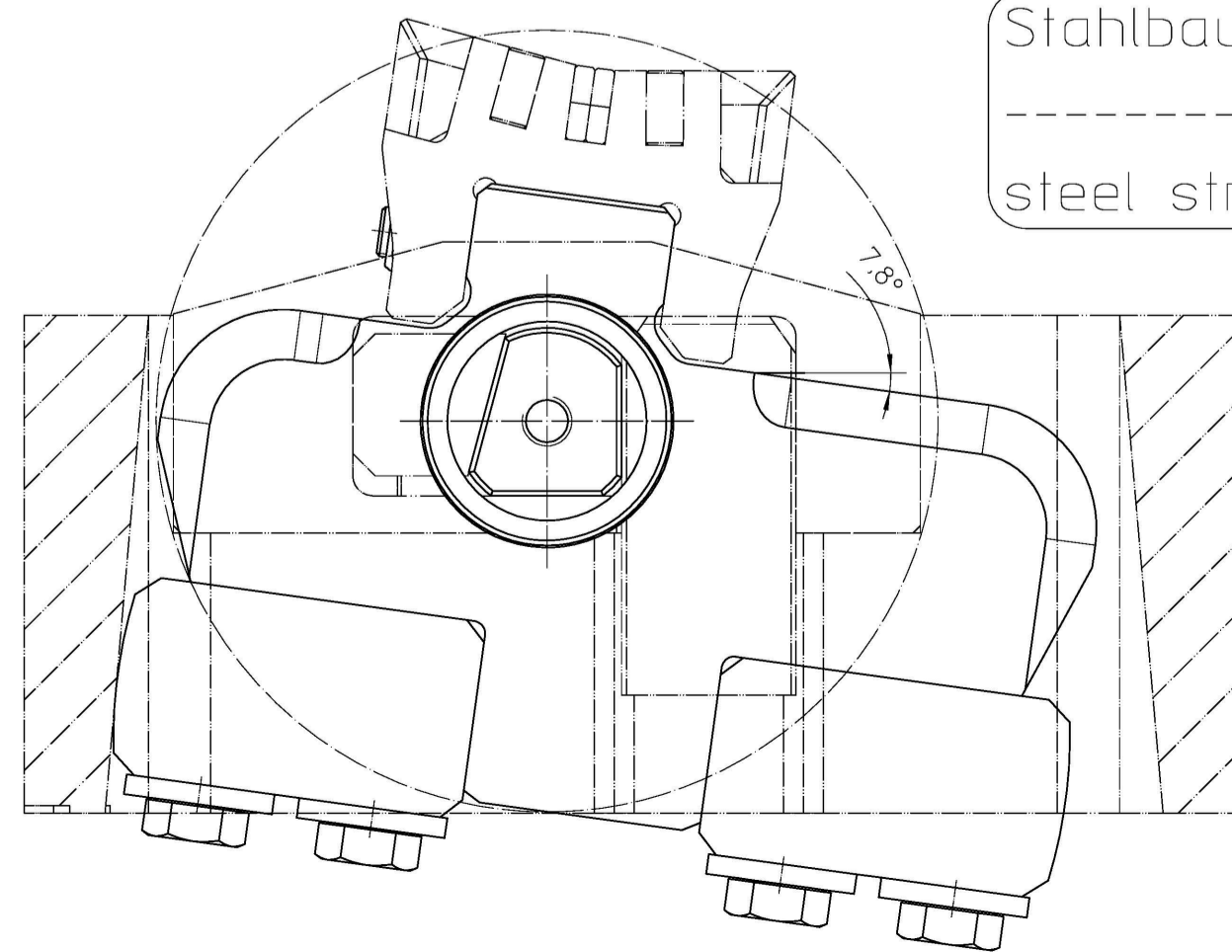

Stahlbau 12"

steel structure 12"

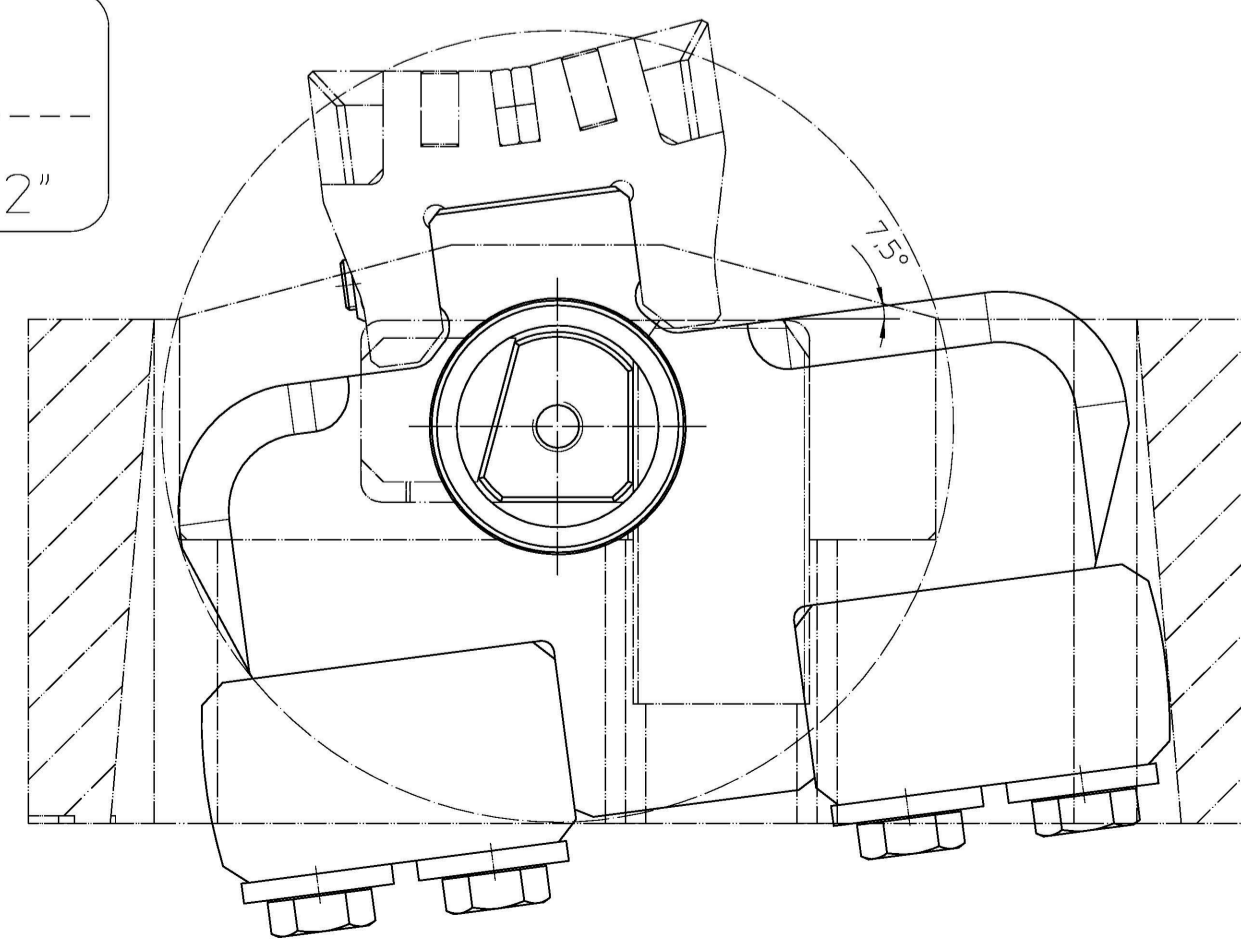

Beschichtungs- und Konservierungsvorgaben gemäß:
Coating- and conservation standards according to:
WN-HKAG-1.2-003

Pos.	Qty.	Designation 1	Material	Designation 2	Material	Partname	Dimension	Material-number	Weight
6	1	HEXNUT ZP M20-10-DIN985						24008007	0.07
7	1	HEXHEAD BOLT M20X130-10.9-DIN931						24000431	0.37
6	1	AXLE RING DA180-D180-L 20-3R	1501-305-011-003					40386645	0.5
5	1	CUTTER SHAFT D80-L 250/3R	1501-011-305-004					40386655	9.6
4	4	WASHER HARDENED Z5-DIN6340						24002320	0.15
3	4	HEXHEAD BOLT M24X130-10.9-DIN931						24000533	0.56
2	2	SPACER BLOCK 110/6L/6.4L/6.3L/HD/KL	1501-457-063-030					40502585	7.3
1	1	RIPPER SUPPORT H66.5/A80D60-M20/3R/KL	1501-305-041-001					40616397	31.5

Revision	Change	Date	Drawn	Date	Released

The reproduction, distribution and utilization of this document as well as the communication of its contents to others without express authorization is prohibited. Offenders will be held liable for the payment of damages. All rights reserved in the event of the grant of a patent, utility model or design. ISO 18018
Edges of undefined shape ISO 13715:2000 Drawing type
Geometrical product specification (GPS) EN ISO 1101:2013 assembly
Surface specifications according to EN ISO 1302:1992 Project
SCHNEIDROLLE Machine type



www.herrrenknecht.com

Name
SUPPORT RIPPER
HALTER STICHEL
H66.5/A80D60-M20/3R/HD/KL

Date	Name	Scale	Material no.	Material	Weight/kg	Projection
09.02.2022	Müller, Michael	1:2	40616842		59.5	1/1

Drawing number
1501-305-041-000

Sheet 1/1
Revision -
Format A1

Released	Date	Name	Scale	Material no.	Material	Weight/kg	Projection
16.02.2022		Vogel, Gabriel	1:2	40616842		59.5	1/1

Baukastenstückliste modular BOM



Projekt
Material 40616842
Bezeichnung 1 HALTER STICHEL

Zchnng.Nr/ver 1501-305-041-000 / -
Gewicht 59,500 KG
Werk 1000

project
material 40616842
description 1 SUPPORT RIPPER

draw.No/ver 1501-305-041-000 / -
weight 59,500 KG
plant

Pos.	Typ type	Material	Menge qty	Bezeichnung 1 / Bezeichnung 2	description 1 / description 2	Zchnng.Nr/ver/Bpf draw.No/ver	Gewicht weight
1	L	40616397	1,000 ST	STICHELHALTER	RIPPER SUPPORT	1501-305-041-001/-	31,50 KG
2	L	40502585	2,000 ST	DISTANZKLOTZ	SPACER BLOCK	1501-457-063-030/-	7,30 KG
3	L	24000533	4,000 ST	SECHSKANTSCHRAUBE M.SCHAFT M24X130-10.9-DIN931	HEX.HEAD BOLT M24X130-10.9-DIN931		0,54 KG
4	L	24002320	4,000 ST	SCHEIBE GEHÄRTET 25-DIN6340	WASHER HARDENED 25-DIN6340		124,00 G
5	L	40386655	1,000 ST	CUTTERACHSE	CUTTER SHAFT	1501-011-305-004/A	9,60 KG
6	L	40386645	1,000 ST	ACHSRING	AXLE RING	1501-305-011-003/-	0,50 KG
7	L	24000431	1,000 ST	SECHSKANTSCHRAUBE M.SCHAFT M20X130-10.9-DIN931	HEX.HEAD BOLT M20X130-10.9-DIN931		0,37 KG
8	L	24008007	1,000 ST	SECHSKANTMUTTER GVZ M20-10-DIN985	HEX.NUT ZP M20-10-DIN985		0,07 KG