

Befestigungsblech / mounting plate
 Art.-Nr. / part no.: 25604969
 Zn.-Nr. / drawing no.: 208-07-023-01

Position Zieltafelhalter von
 Maschinengröße abhängig
 siehe Zusammenstellung Vortriebsmaschine
 position of the laser target holder is
 depending on the size from the machine
 look at assembly of tunneling machine

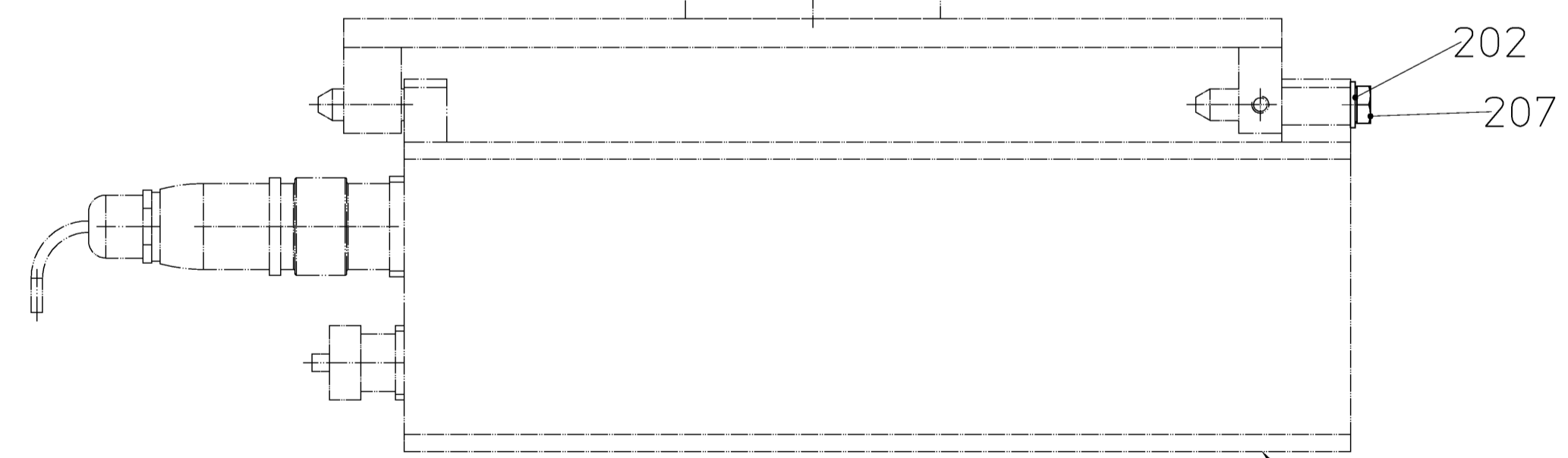
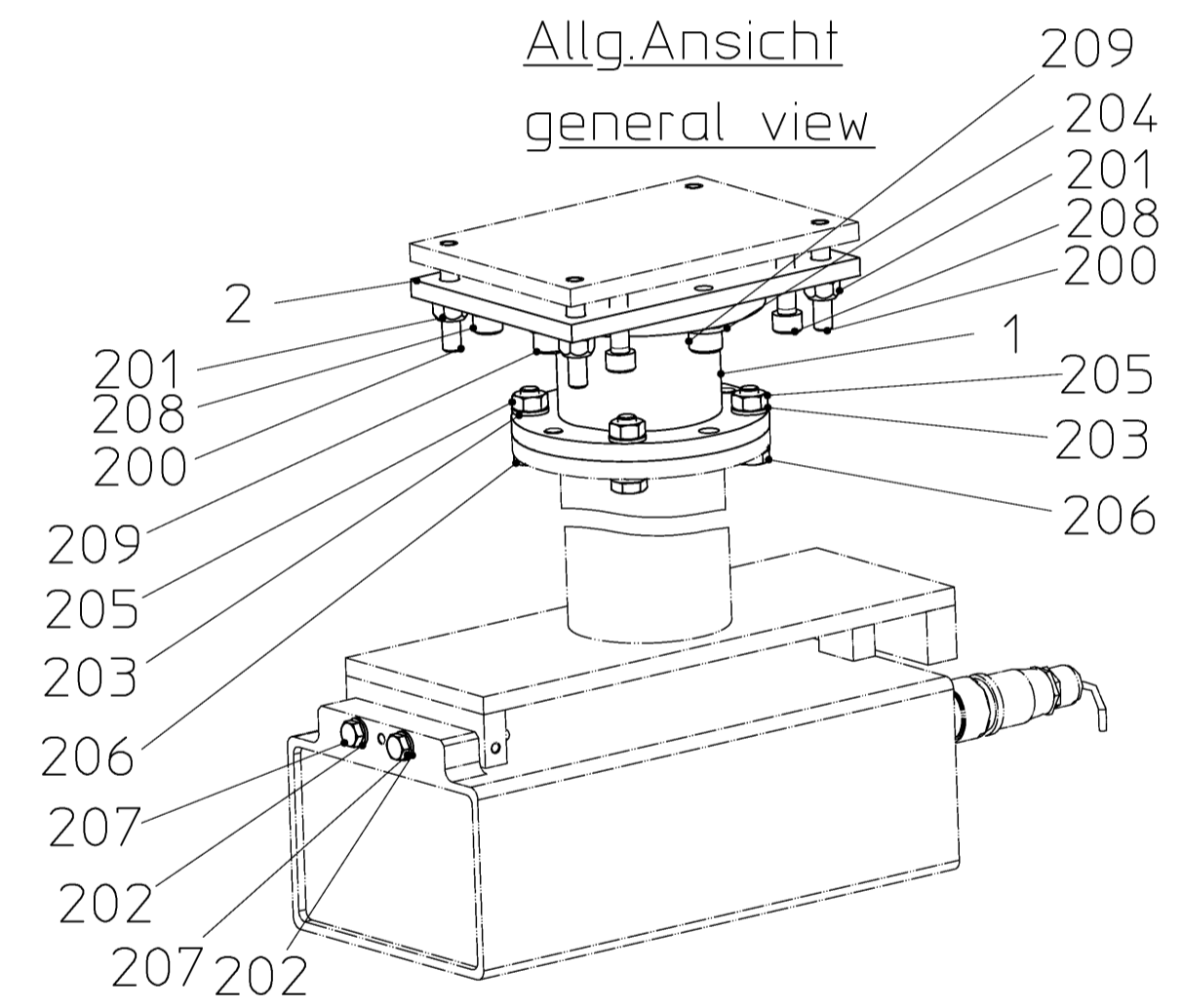
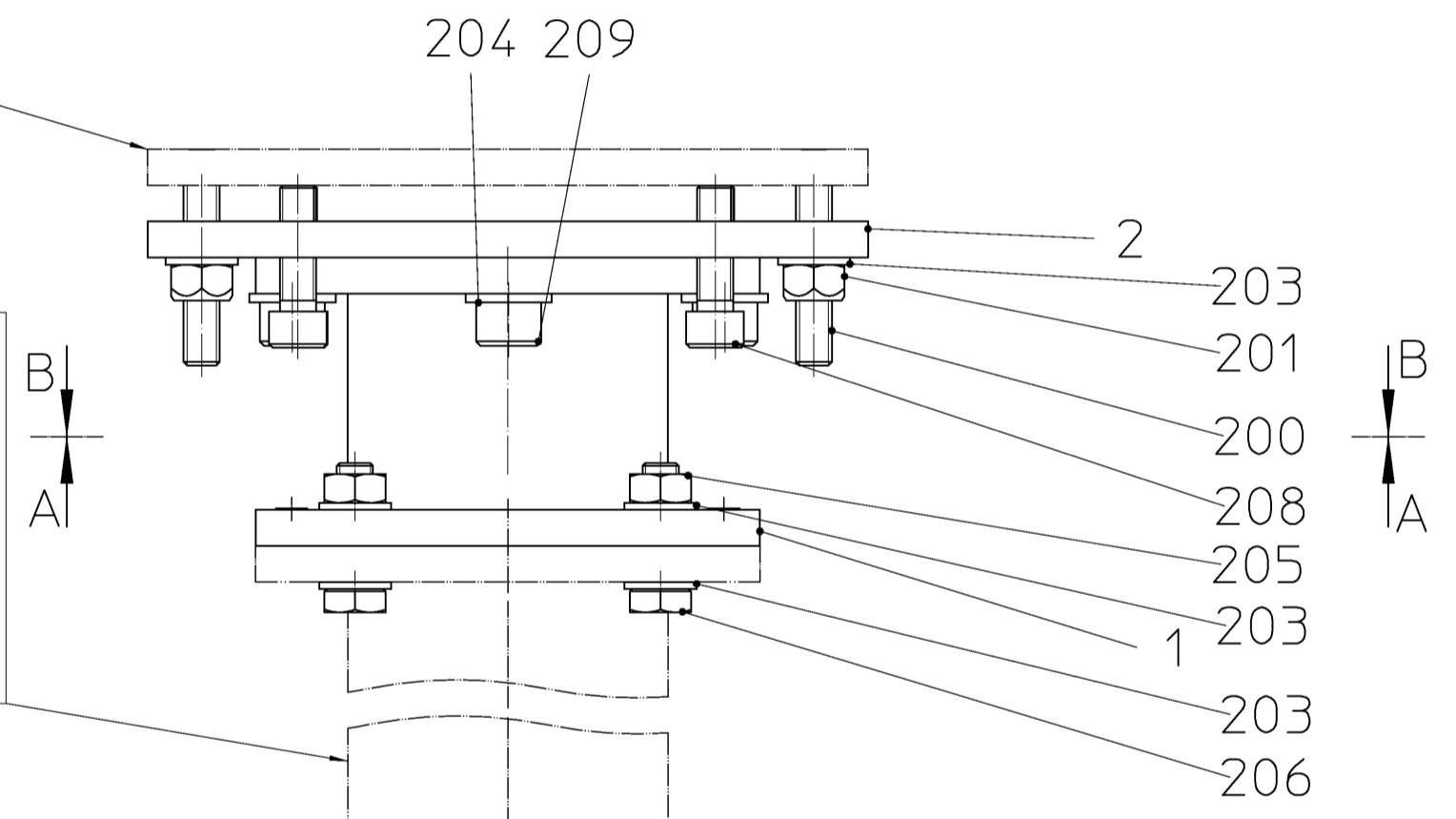

Zieltafel / laser target
 Art.-Nr. / part no.: 26400800

The reproduction, distribution and utilization of this document as well as the communication of its contents to others without express authorization is prohibited. Offenders will be held liable for the payment of damages. All rights reserved in the event of the grant of a patent, utility model or design. ISO 16016											
name LASER TARGET HOLDER ELS2-TB			drawing type assembly		scale 1:2		general tolerances				
drawing number 208-07-023-80			part number 25103377		weight/kg 7						
sheet nr. index 1/1 H			projection 		surface specifications according to ISO 1302:1992						
H	Zeichnung war ME10; Stückliste geändert				26.10.2015	SRI	27.10.2015	MSchu			
G	Texte berichtigt;				20.04.2015	WV	20.04.2015	ST			
F	Englischer Schriftkopf hinzu				30.10.2009	Bec	02.11.2009	ST			
Index		Änderung		Datum	Bearb.	Datum	Gepr.				
Weitergabe sowie Vervielfältigung dieses Dokuments, Verwertung und Mitteilung seines Inhalts sind verboten, soweit nicht ausdrücklich gestattet. Zuwiderhandlungen verpflichten zu Schadenersatz. Alle Rechte für den Fall der Patent-, Gebrauchsmuster- oder Geschmacksmuster-Eintragung vorbehalten. ISO 16016											
HERRENKNECHT AG Schlehenweg 2 D-77963 Schwanau Tel.: 07824/302-0 Fax: 07824/3403 www.herrenknecht.de			HERRENKNECHT Tunnelvortriebstechnik		Zeichnung Projekt Zusammenstellung AVN/AVT		Maschinentyp				
Benennung ZIELTAFELHALTER ELS2-TB			Zeichnungsnummer 208-07-023-80		Blatt Nr. 1/1		Index H				
Bearbeitet	11.09.1998	Urbaneck H.	Oberflächen- angabe nach ISO 1302:1992		Maßstab 1:2		Artikelnummer 25103377		Werkstoff	Gewicht/kg 7	Format A2
Geprüft	28.09.1998	Bitterer	Projektion 								

Baukastenstückliste modular BOM



Projekt
Material 25103377
Bezeichnung 1 ZIELTAFELHALTER

Zchnng.Nr/ver 208-07-023-80 / H
Gewicht 7 KG
Werk 1000

project
material 25103377
description 1 LASER TARGET HOLDER

draw.No/ver 208-07-023-80 / H
weight 7 KG
plant

Pos.	Typ type	Material	Menge qty	Bezeichnung 1 / Bezeichnung 2	description 1 / description 2	Zchnng.Nr/ver/Bpf draw.No/ver	Gewicht weight
1	L	25632053	1,000 ST	DISTANZSTÜCK	SPACER PIECE	208-07-023-82/A	3,50 KG
2	L	25603480	1,000 ST	VERSTELLPLATTE	ADJUSTMENT PLATE	208-07-023-02/B	2,10 KG
200	L	24000970	4,000 ST	GEWINDESTIFT M10X60-45H-ISO4026	SET SCREW M10X60-45H-ISO4026		28,64 G
201	L	24008006	4,000 ST	SECHSKANTMUTTER GVZ M10-8-DIN985	HEX.NUT ZP M10-8-DIN985		10,00 G
202	L	24000209	2,000 ST	SCHEIBE GVZ A8,4-140HV-DIN125	WASHER ZP A8,4-140HV-DIN125		1,83 G
203	L	24000210	12,000 ST	SCHEIBE GVZ A10,5-140HV-DIN125	WASHER ZP A10,5-140HV-DIN125		3,57 G
204	L	24000211	4,000 ST	SCHEIBE GVZ A13-140HV-DIN125	WASHER ZP A13-140HV-DIN125		6,00 G
205	L	24001798	4,000 ST	SECHSKANTMUTTER GVZ M10-8-DIN934	HEX.NUT ZP M10-8-DIN934		11,60 G
206	L	24002905	4,000 ST	SECHSKANTSCHRAUBE GVZ M10X35-8.8-DIN933	HEX.HEAD SCREW ZP M10X35-8.8-DIN933		0,03 KG
207	L	24004849	2,000 ST	SECHSKANTSCHRAUBE M.SCHAFT GVZ M8X45-8.8-DIN931	HEX.HEAD BOLT ZP M8X45-8.8-DIN931		0,02 KG
208	L	24007724	4,000 ST	ZYLINDERSCHRAUBE GVZ M10X35-8.8-DIN912	HEX.SOCKET HEAD CAP SCREW ZP M10X35-8.8-DIN912		0,03 KG
209	L	24007726	4,000 ST	ZYLINDERSCHRAUBE GVZ M12X20-8.8-DIN912	HEX.SOCKET HEAD CAP SCREW ZP M12X20-8.8-DIN912		0,03 KG

* Z = Infoteil
* Z = reference part