

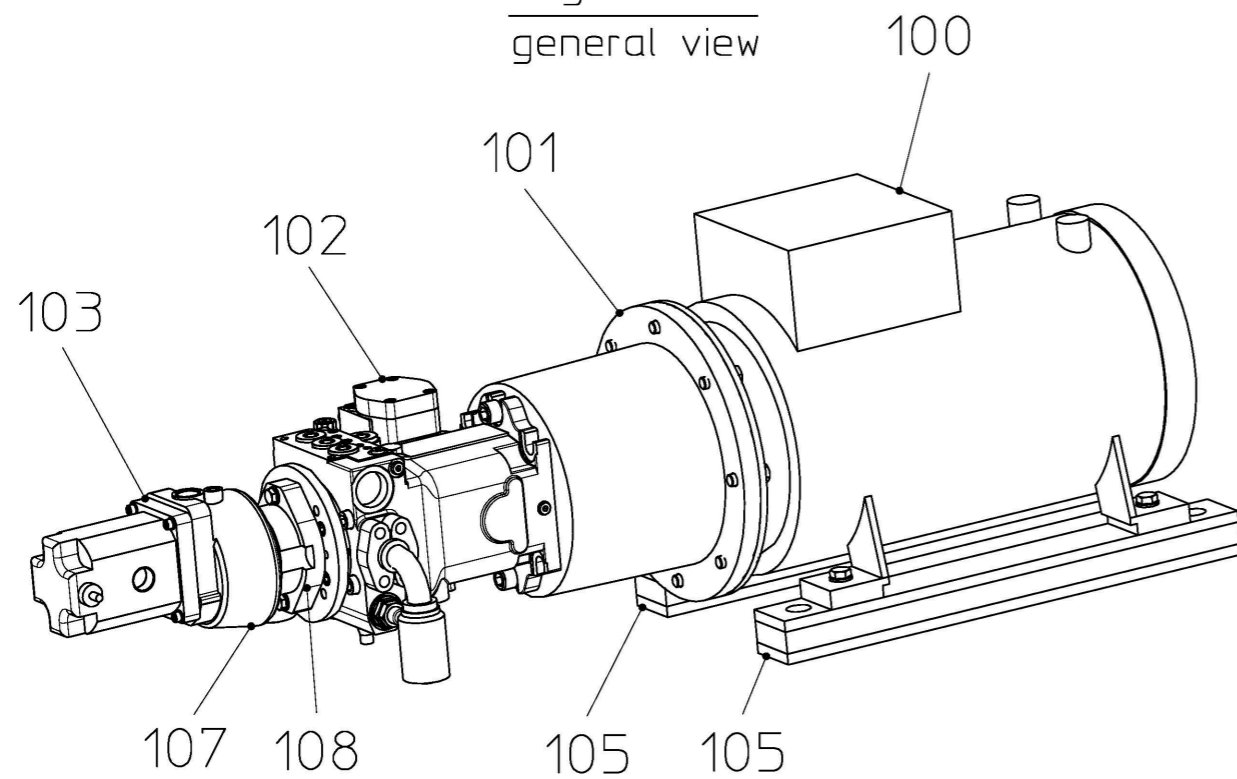

Allg. Ansicht
general view



Wenn nicht anderweitig angegeben, sind metrische Schraffschrauben entsprechend den HERRENKNECHT-Anweisungen nach folgender Tabelle anzuziehen
 Schrauben-Anzugsmomente in Nm
 nach A-MBQ002, A-GW002, A-FS003 und A-MT005
 Reibungskoeffizient $\mu_{ges} = 0,12$

If not defined otherwise, metric screws have to be tightened in accordance with the prescriptions from HERRENKNECHT in the following table
 Screw tightening torques in Nm
 following A-MBQ002, A-GW002, A-FS003 and A-MT005
 coefficient of friction $\mu_{tot} = 0,12$

	5,6	8,8	10,9	12,9
M8	10,5	24	34	40
M12	35	75	110	130
M16	85	180	265	310
M20	165	360	520	600

Revision	Change	Date	Drawn	Date	Released
The reproduction, distribution and utilization of this document as well as the communication of its contents to others without express authorization is prohibited. Offenders will be held liable for the payment of damages. All rights reserved in the event of the grant of a patent, utility model or design. ISO 16016		General tolerances			
Edges of undefined shape	ISO 13715:2000	Drawing type		assembly	
Geometrical product specification	(GPS) EN ISO 1101:2013	Project		Machine type	
Surface specifications according to	EN ISO 1302:1992	STANDARD-AVN			
 www.herrenknecht.com		Name			
		MOTOR PUMP UNIT MOTORPUMPENEINHEIT 75KW A4VG125-RZ5.3-PGP517			
Drawing number		Sheet	Revision	Format	
809-32-103-20		1/1	-	A3	
Drawn	Date	Name	Scale	Material no.	Material
Released	02.03.2022	Steiner, Thomas	1:10	40620373	
	13.07.2022	Mannherz, Daniel			
				Weight/kg	Projection
				555	

Baukastenstückliste modular BOM



Projekt
Material 40620373
Bezeichnung 1 MOTORPUMPENEINHEIT
Zchnng.Nr/ver 809-32-103-20 / -
Gewicht 555 KG
Werk 1000

project
material 40620373
description 1 MOTOR PUMP UNIT
draw.No/ver 809-32-103-20 / -
weight 555 KG
plant

Pos.	Typ type	Material	Menge qty	Bezeichnung 1 / Bezeichnung 2	description 1 / description 2	Zchnng.Nr/ver/Bpf draw.No/ver	Gewicht weight
100	Z	23000579	1,000 ST	DREHSTROM-ASYNCHRONMOTOR	THREE-PHASE ASYNCHRON. MOTOR		400,00 KG
101	Z	23800292	1,000 ST	PUMPENTRÄGER	PUMP CARRIER		0,00 KG
102	Z	23503694	1,000 ST	AXIALKOLBEN-VERSTELLPUMPE	AXIAL PISTON VARIABLE PUMP		84,00 KG
103	Z	23502453	1,000 ST	ZAHNRADPUMPE	GEAR PUMP		10,50 KG
104	Z	23700606	1,000 ST	KUPPLUNG ELASTISCH	COUPLING ELASTIC		13,51 KG
105	Z	23904649	2,000 ST	DÄMPFUNGSSCHIENE	DAMPING RAIL		14,70 KG
106	Z	25602878	1,000 ST	VERBINDUNGSSTÜCK	CONNECTING PIECE	208-10-001-03/F	0,34 KG
107	Z	23500728	1,000 ST	RADIALKOLBENPUMPE	RADIAL PISTON PUMP		9,20 KG
108	Z	25633933	1,000 ST	ZWISCHENFLANSCH	INTERMEDIATE FLANGE	208-10-001-17/B	5,60 KG
200	L	24001793	2,000 ST	SECHSKANTSCHRAUBE GVZ M12X45-8.8-DIN933	HEX.HEAD SCREW ZP M12X45-8.8-DIN933		0,05 KG
201	L	24001937	4,000 ST	SECHSKANTSCHRAUBE GVZ M16X40-8.8-DIN933	HEX.HEAD SCREW ZP M16X40-8.8-DIN933		0,09 KG
202	L	24004789	2,000 ST	ZYLINDERSCHRAUBE GVZ M20X40-8.8-DIN912	HEX.SOCKET HEAD CAP SCREW ZP M20X40-8.8-DIN912		0,15 KG
203	L	24000803	8,000 ST	SECHSKANTSCHRAUBE M16X45-10.9-DIN933	HEX.HEAD SCREW M16X45-10.9-DIN933		0,10 KG
204	L	24001914	4,000 ST	ZYLINDERSCHRAUBE GVZ M8X40-8.8-DIN912	HEX.SOCKET HEAD CAP SCREW ZP M8X40-8.8-DIN912		0,02 KG
205	L	24000184	8,000 ST	SCHEIBE A19-140HV-DIN125	WASHER A19-140HV-DIN125		14,70 G
206	L	24001372	4,000 ST	SCHEIBE GVZ A17-140HV-DIN125	WASHER ZP A17-140HV-DIN125		11,30 G
207	L	24000209	4,000 ST	SCHEIBE GVZ A8,4-140HV-DIN125	WASHER ZP A8,4-140HV-DIN125		1,83 G
208	L	24000211	2,000 ST	SCHEIBE GVZ A13-140HV-DIN125	WASHER ZP A13-140HV-DIN125		6,00 G

* Z = Infoteil
* Z = reference part