

Schildschwanz  
Produktrohr abhängig/  
tailskin depends on  
product pipe

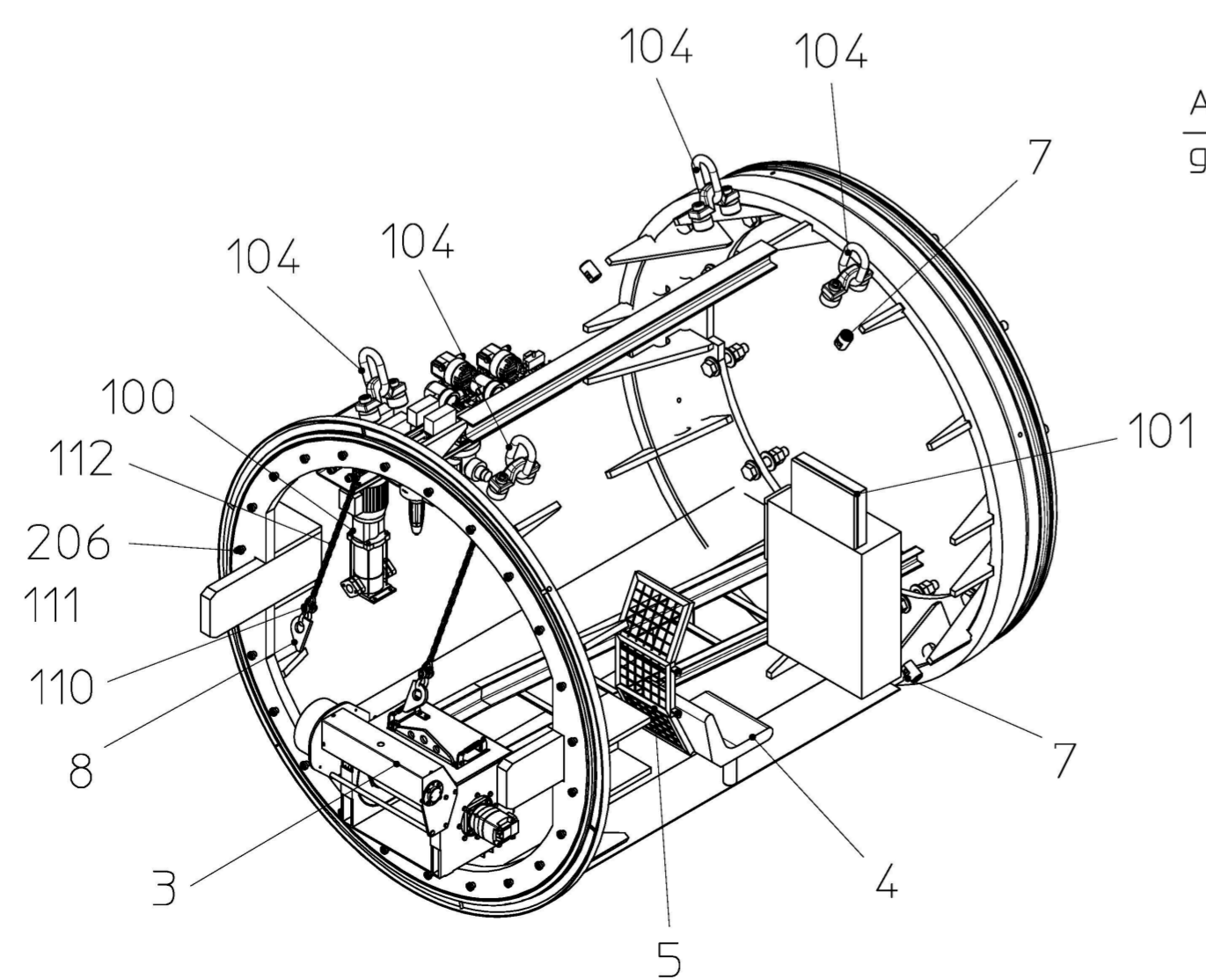

Allg. Ansicht  
general view  
1:30

Wenn nicht anderweitig angegeben, sind metrische Schallschrauben entsprechend den HERRENKNECHT-Anweisungen nach folgender Tabelle anzuziehen

**Schrauben-Anzugsmomente in Nm**  
nach A-MBQ002, A-GW002, A-FS003 und A-MT005  
Reibungskoeffizient  $\mu_{ges.} = 0,12$

If not defined otherwise, metric screws have to be tightened in accordance with the prescriptions from HERRENKNECHT in the following table

**Screw tightening torques in Nm**  
following A-MBQ002, A-GW002, A-FS003 and A-MT005  
coefficient of friction  $\mu_{tot} = 0,12$

	5.6	8.8	10.9	12.9
M16	85	180	265	310
M24	285	630	890	1050
M36	980	2150	3100	3600
M42	1550	3450	4900	5800

Werksmontagezeit  
Workshop assembly welding seam  
Soudure de montage d'atelier

D	Pos.8, 110-112 hinzu	20.07.2022	schroetv	21.07.2022	mannherd
C	Zeichnung aktualisiert	12.07.2022	schroetv	13.07.2022	mannherd
B	Pos. 108 Länge geändert, Pos. 214 Art.Nr. war 24007169	12.07.2002	schulzld	12.07.2002	fichta
Revision	Change	Date	Drawn	Date	Released
The reproduction, distribution and utilization of this document as well as the communication of its contents to others without express authorization is prohibited. Offenders will be held liable for the payment of damages. All rights reserved in the event of the grant of a patent, utility model or design. ISO 16016		General tolerances			
Edges of undefined shape		ISO 13715:2000		Drawing type assembly	
Geometrical product specification		(GPS) EN ISO 1101:2013		Machine type EPB2000T-01	
Surface specifications according to		EN ISO 1302:1992		Project M-722M	
 www.herrenknecht.com		Name		MACHINE PIPE 2	
		Name		MASCHINENROHR 2	
Date		Name		Drawing number	
19.04.2002		Schulzle, Dominic		1187-01-006-00	
Released		25.04.2002		Ficht Alexander	
Scale		Material no.		Material	
1:20		30027595			
Sheet		Revision		Format	
1/1		D		A2	
Weight/kg		Projection			
10234					

# Baukastenstückliste modular BOM



Projekt  
Material 30027595  
Bezeichnung 1 MASCHINENROHR 2  
  
Zchnng.Nr/ver 1187-01-006-00 / D  
Gewicht 10.234 KG  
Werk 1000

project  
material 30027595  
description 1 MACHINE PIPE 2  
  
draw.No/ver 1187-01-006-00 / D  
weight 10.234 KG  
plant

Pos.	Typ type	Material	Menge qty	Bezeichnung 1 / Bezeichnung 2	description 1 / description 2	Zchnng.Nr/ver/Bpf draw.No/ver	Gewicht weight
1	L	30027940	1,000 ST	MASCHINENROHR 2	MACHINE PIPE 2		9.589,00 KG
2	L	30079860	2,000 ST	WANNE	TRAY	1803-06-001-24/C	18,00 KG
3	L	40383762	1,000 ST	SEILWINDE	CABLE WINCH		320,00 KG
4	L	30219174	1,000 ST	FAHRERSITZ	DRIVER SEAT	3474-01-006-30/-	19,00 KG
5	L	30208829	1,000 ST	SICHERHEITSTÜR	SAFETY DOOR	3474-01-006-08/-	6,50 KG
6	L	30045287	2,000 ST	DOSIEREINHEIT	DOSING UNIT	809-01-056-10/G	16,10 KG
7	L	25102954	4,000 ST	BENTONITDÜSE	BENTONITE NOZZLE	809-01-040-00/F	1,60 KG
8	L	25640464	2,000 ST	LASCHE	LUG		1,10 KG
100	Z	40140825	1,000 ST	KREISELPUMPENEINHEIT	CENTRIFUGAL PUMP UNIT		33,00 KG
101	Z	26604814	1,000 ST	KLEMMENKASTEN	TERMINAL BOX		4,50 KG
102	L	28100842	1,000 ST	DICHTUNGSPROFILRING	SEALING PROFILE RING		18,50 KG
103	L	28201562	1,000 ST	RUNDSCHNUR ENDLOS	ROUND CORD ENDLESS		0,43 KG
104	L	29500684	4,000 ST	ANSCHLAGPUNKT TRANSPORTRING	LIFTING POINT TRANSPORT RING		11,40 KG
105	Z	40519693	1,000 ST	SCHALTSCHRANK	SWITCH CABINET		32,00 KG
106	Z	29918140	1,000 ST	DOSIEREINHEIT	DOSING UNIT		5,60 KG
107	Z	29918139	1,000 ST	DOSIEREINHEIT	DOSING UNIT		5,50 KG
108	L	24900046	1,000 ST	FEDERSTECKER GVZ	SPRING COTTER ZP		61,00 G
109	Z	26603813	1,000 ST	KLIMAGERÄT SCHALTSCHRANK	AIR CONDITIONER SWITCH CABINET		6,23 KG
110	L	22690001	4,000 ST	SCHÄKEL	SHACKLE		0,65 KG
111	L	29900395	4,000 ST	VERBINDUNGSGLIED	CONNECTING LINK		0,20 KG
112	R	29500279	1,240 M	ANSCHLAGKETTE L = 620,0	SLING CHAIN		1,40 KG
200	L	24002424	12,000 ST	SECHSKANTSCHRAUBE M.SCHAFT M42X220-10.9-DIN931	HEX.HEAD BOLT M42X220-10.9-DIN931		2,96 KG
201	L	24000121	24,000 ST	SECHSKANTMUTTER M42-10-DIN934	HEX.NUT M42-10-DIN934		0,58 KG

\* Z = Infoteil  
\* Z = reference part

# Baukastenstückliste modular BOM

Projekt  
Material [30027595](#)  
Bezeichnung 1 MASCHINENROHR 2  
description 1 MACHINE PIPE 2

Pos.	Typ type	Material	Menge qty	Bezeichnung 1 / Bezeichnung 2	description 1 / description 2	Zchnng.Nr/ver/Bpf draw.No/ver	Gewicht weight
202	L	24000184	8,000 ST	SCHEIBE A19-140HV-DIN125	WASHER A19-140HV-DIN125		14,70 G
203	L	24000197	24,000 ST	SCHEIBE B50-140HV-DIN125	WASHER B50-140HV-DIN125		240,00 G
204	L	24007235	8,000 ST	VERSCHLUSSSCHRAUBE M36X4-5.8-DIN906	PLUG SCREW M36X4-5.8-DIN906		0,07 KG
205	L	24002160	4,000 ST	SECHSKANTMUTTER GVZ M16-8-DIN934	HEX.NUT ZP M16-8-DIN934		33,30 G
206	L	24004183	24,000 ST	ZYLINDERSCHRAUBE M24X50-8.8-DIN7984	HEX.SOCKET HEAD CAP SCREW M24X50-8.8-DIN7984		0,22 KG
207	L	24007917	4,000 ST	SECHSKANTSCHRAUBE M.SCHAFT GVZ M16X60-8.8-DIN931	HEX.HEAD BOLT ZP M16X60-8.8-DIN931		0,12 KG