

Maschinenrohr 2/
machine pipe 2
Art. Nr.: 30027595
Zn.Nr.: 1187-01-006-00

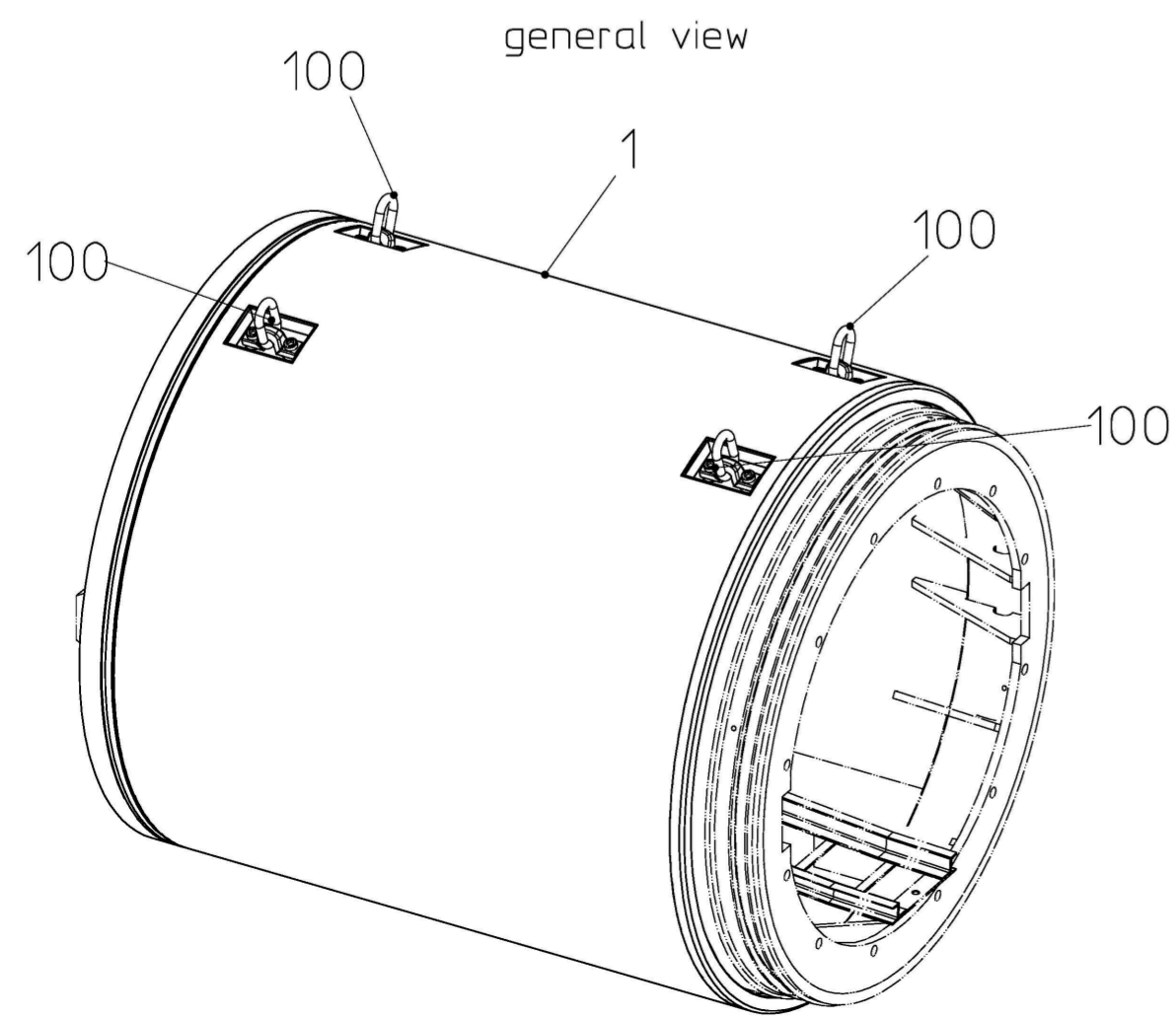

Wenn nicht anderweitig angegeben, sind metrische Schraffenschrauben entsprechend den HERRENKNECHT-Anweisungen nach folgender Tabelle anzuziehen

Schrauben-Anzugsmomente in Nm
nach AA-HKAG-2.5-026
Reibungskoeffizient $\mu_{ges.} = 0,12$



If not defined otherwise, metric screws have to be tightened in accordance with the prescriptions from HERRENKNECHT in the following table

Screw tightening torques in Nm
according to AA-HKAG-2.5-026
coefficient of friction $\mu_{tot.} = 0,12$

	5.6	8.8	10.9	12.9
M20	165	360	520	600
M24	285	630	890	1050
M42	1550	3450	4900	5800

Maschine/ machine	8300kg	Gesamtgewicht/ total weight 13640kg
AD/ upsized shell	5340kg	

Pos.500 Transportsituation Art.Nr.: 40628252

Revision	A	Pos.500 hinzugefügt	28.04.2022	hurstk	28.04.2022	mannherd
Change			Date	Drawn	Date	Released
The reproduction, distribution and utilization of this document as well as the communication of its contents to others without express authorization is prohibited. Offenders will be held liable for the payment of damages. All rights reserved in the event of the grant of a patent, utility model or design. ISO 16016			General tolerances			
Edges of undefined shape			ISO 13715:2000		Drawing type assembly	
Geometrical product specification			(GPS) EN ISO 1101:2013		Project M-722M	
Surface specifications according to			EN ISO 1302:1992		Machine type EPB2000T-01	
 www.herrenknecht.com			Name UPSIZED SHELL AUFDOPPELMANTEL DA2615-MR2			
			Drawing number 1187-08.1-006-00			Sheet 1/1
Date	Name		Scale		Material no.	Material
08.03.2022	Hoffmann, Alex		1:15		40619891	Weight/kg 5340
Released	07.04.2022 Mannherz, Daniel					Projection 

Baukastenstückliste modular BOM



Projekt
Material 40619891
Bezeichnung 1 AUFDOPPELMANTEL

Zchnng.Nr/ver 1187-08.1-006-00 / A
Gewicht 5.340 KG
Werk 1000

project
material 40619891
description 1 UPSIZE SHELL

draw.No/ver 1187-08.1-006-00 / A
weight 5.340 KG
plant

Pos.	Typ type	Material	Menge qty	Bezeichnung 1 / Bezeichnung 2	description 1 / description 2	Zchnng.Nr/ver/Bpf draw.No/ver	Gewicht weight
1	L	40619888	1,000 ST	AUFDOPPELMANTEL STAHLBAU	UPSIZESH SHELL STEEL STRUCTURE	1187-08.1-006-01/-	5.280,00 KG
100	Z	29500684	4,000 ST	ANSCHLAGPUNKT TRANSPORTRING	LIFTING POINT TRANSPORT RING		11,40 KG
101	Z	28201780	1,000 ST	RUNDSCHNUR ENDLOS	ROUND CORD ENDLESS		0,41 KG
200	L	24002027	24,000 ST	ZYLINDERSCHRAUBE GVZ M24X50-8.8-DIN912	HEX.SOCKETH HEAD CAP SCREW ZP M24X50-8.8-DIN912		0,30 KG
500	L	40628252	1,000 ST	TRANSPORTSITUATION	TRANSPORT SITUATION	1187-08.1-006-91/-	41,09 KG

* Z = Infoteil
* Z = reference part