

Maschinenrohr 2/
machine pipe 2
Art. Nr.: 30027868
Zn.Nr.: 1187-01-006-02

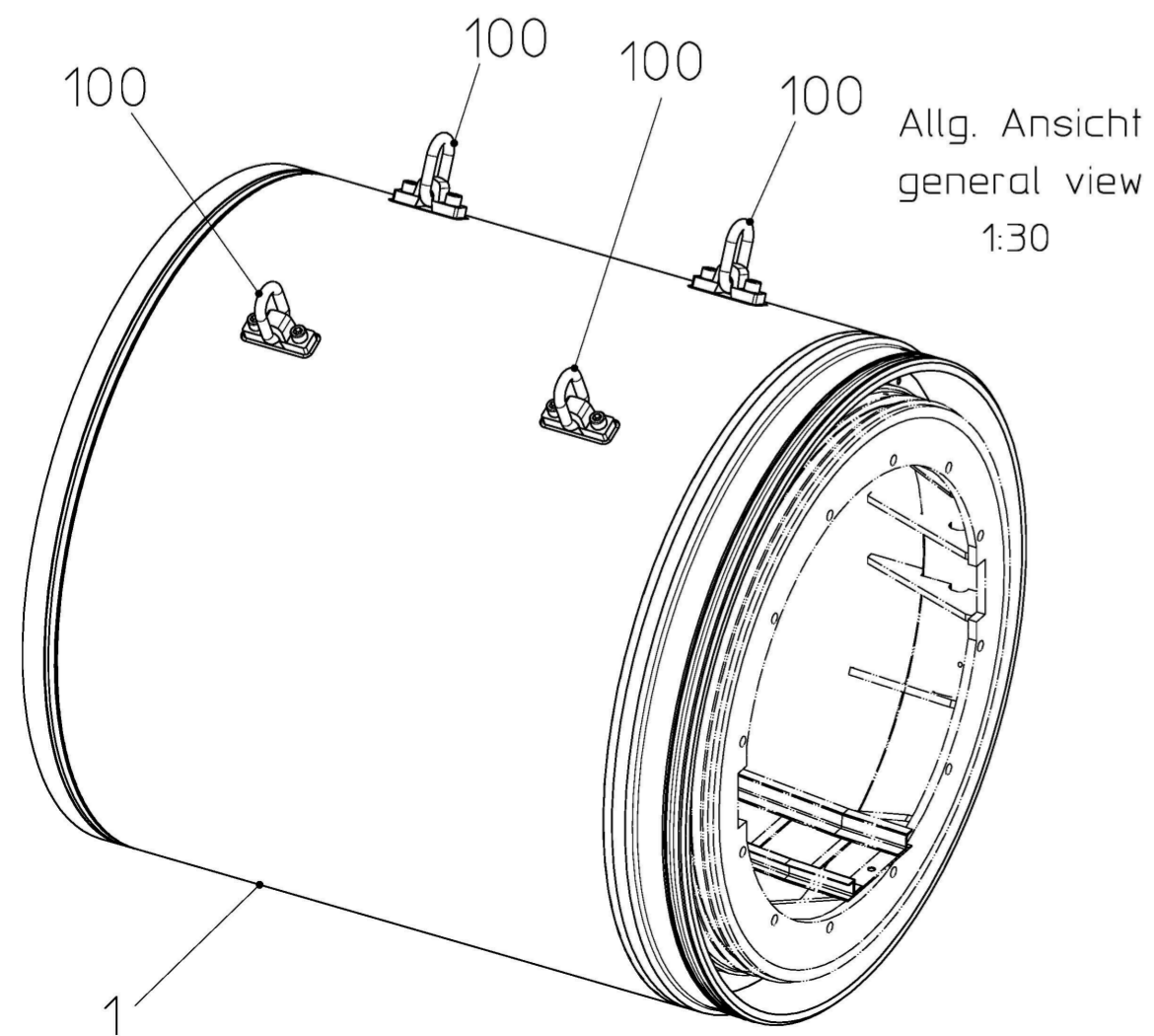

Wenn nicht anderweitig angegeben, sind metrische Schraffschrauben entsprechend den HERRENKNECHT-Anweisungen nach folgender Tabelle anzuziehen

Schrauben-Anzugsmomente in Nm
nach AA-HKAG-2.5-026
Reibungskoeffizient $\mu_{ges.} = 0,12$

If not defined otherwise, metric screws have to be tightened in accordance with the prescriptions from HERRENKNECHT in the following table

Screw tightening torques in Nm
according to AA-HKAG-2.5-026
coefficient of friction $\mu_{tot.} = 0,12$

	5.6	8.8	10.9	12.9
M20	165	360	520	600
M24	285	630	890	1050
M42	1550	3450	4900	5800

Maschine/ machine	9736kg	Gesamtgewicht/ total weight 17118kg
AD/ upsized shell	7382kg	

Pos.500 Transportsituation Art.Nr.: 40619735

Revision	A	Pos.500 hinzugefügt	28.04.2022	hursik	28.04.2022	mannherz
Change			Date	Drawn	Date	Released
The reproduction, distribution and utilization of this document as well as the communication of its contents to others without express authorization is prohibited. Offenders will be held liable for the payment of damages. All rights reserved in the event of the grant of a patent, utility model or design. ISO 16016			General tolerances			
Edges of undefined shape		ISO 13715:2000	Drawing type		assembly	
Geometrical product specification		(GPS) EN ISO 1101:2013	Project		Machine type	
Surface specifications according to		EN ISO 1302:1992	M-722M		EPB2000T-01	
 www.herrenknecht.com			Name		UPSIZE SHELL	
			Name		AUFDOPPELMANTEL	
Date		Name		Drawing number		Sheet
24.02.2022		Schirrmann, Axel		1187-08-006-00		1/1
Released		07.04.2022		Mannherz, Daniel		Revision
				Scale		A
				Material no.		Format
				1:15		A2
				Material		Weight/kg
				40619015		7382
				Material		Projection
						1st angle

Baukastenstückliste modular BOM



Projekt
Material 40619015
Bezeichnung 1 AUFDOPPELMANTEL

Zchnng.Nr/ver 1187-08-006-00 / A
Gewicht 7.382 KG
Werk 1000

project
material 40619015
description 1 UPSIZE SHELL

draw.No/ver 1187-08-006-00 / A
weight 7.382 KG
plant

Pos.	Typ type	Material	Menge qty	Bezeichnung 1 / Bezeichnung 2	description 1 / description 2	Zchnng.Nr/ver/Bpf draw.No/ver	Gewicht weight
1	L	40619014	1,000 ST	AUFDOPPELMANTEL STAHLBAU	UPSIZESH SHELL STEEL STRUCTURE	1187-08-006-01/A	7.275,00 KG
100	L	29501076	4,000 ST	ANSCHLAGPUNKT TRANSPORTRING	LIFTING POINT TRANSPORT RING		19,30 KG
101	L	28100781	1,000 ST	DICHTUNGSPROFILRING	SEALING PROFILE RING		20,00 KG
102	Z	28201780	1,000 ST	RUNDSCHNUR ENDLOS	ROUND CORD ENDLESS		0,41 KG
200	L	24007169	8,000 ST	VERSCHLUSSSCHRAUBE M42X4,5-5.8-DIN906	PLUG SCREW M42X4,5-5.8-DIN906		0,12 KG
201	L	24002027	24,000 ST	ZYLINDERSCHRAUBE GVZ M24X50-8.8-DIN912	HEX.SOCKET HEAD CAP SCREW ZP M24X50-8.8-DIN912		0,30 KG
500	L	40619735	1,000 ST	TRANSPORTSITUATION	TRANSPORT SITUATION	1187-08-006-90/A	121,72 KG

* Z = Infoteil
* Z = reference part