

DISC CUTTER Ø305 / 12 Inch
2 cutting rings
cutter space 72mm

Pos. 200

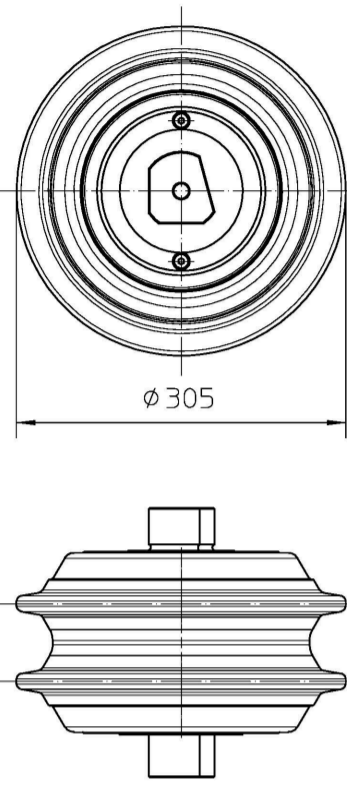

Type: standard
monoblock-hub
max. contact force: 20 to.

Pos. 210

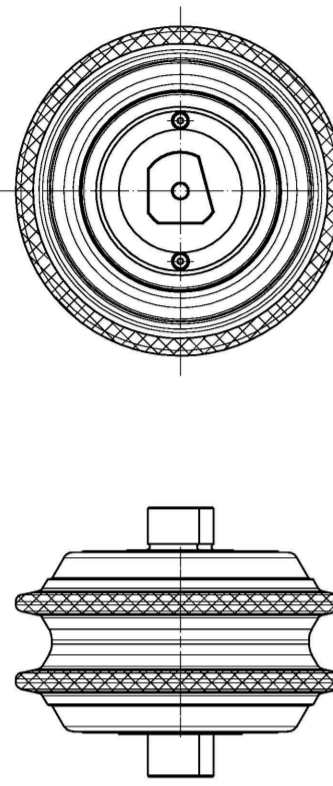

Type: hard-facing
monoblock-hub
max. contact force: 20 to.

Pos. 230

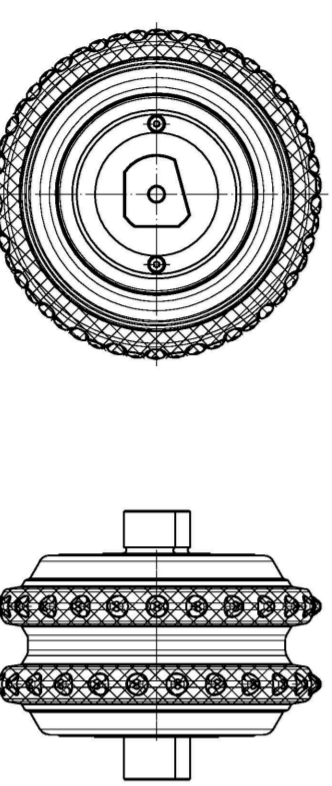

Type: tungsten carbide insert
monoblock-hub
hard-facing
max. contact force: 20 to.

Pos. 250

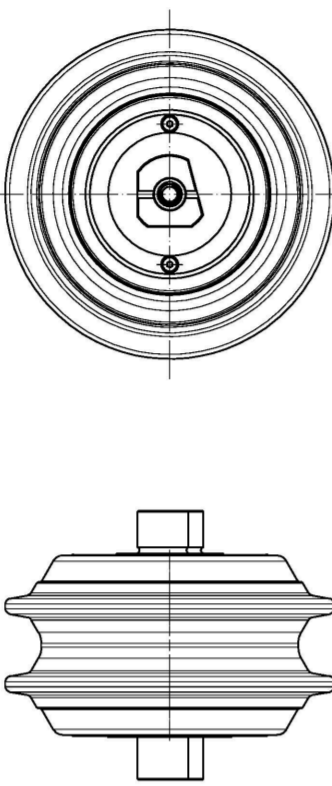

Type: standard
monoblock-hub
pressure compensated
max. contact force: 20 to.

Pos. 300

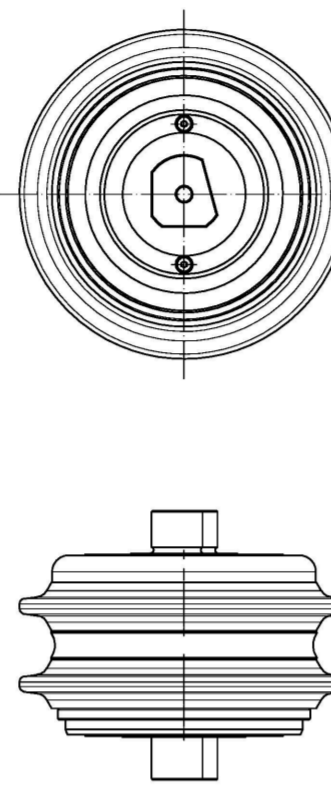

Type: standard
changeable cutter-ring
max. contact force: 20 to.

Pos. 350

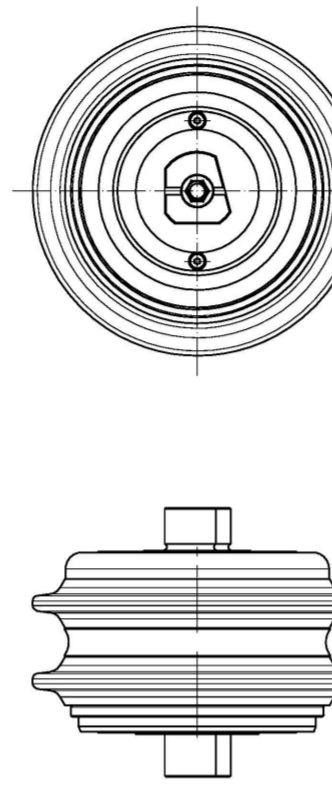

Type: standard
changeable cutter-ring
pressure compensated
max. contact force: 20 to.

Pos. 400

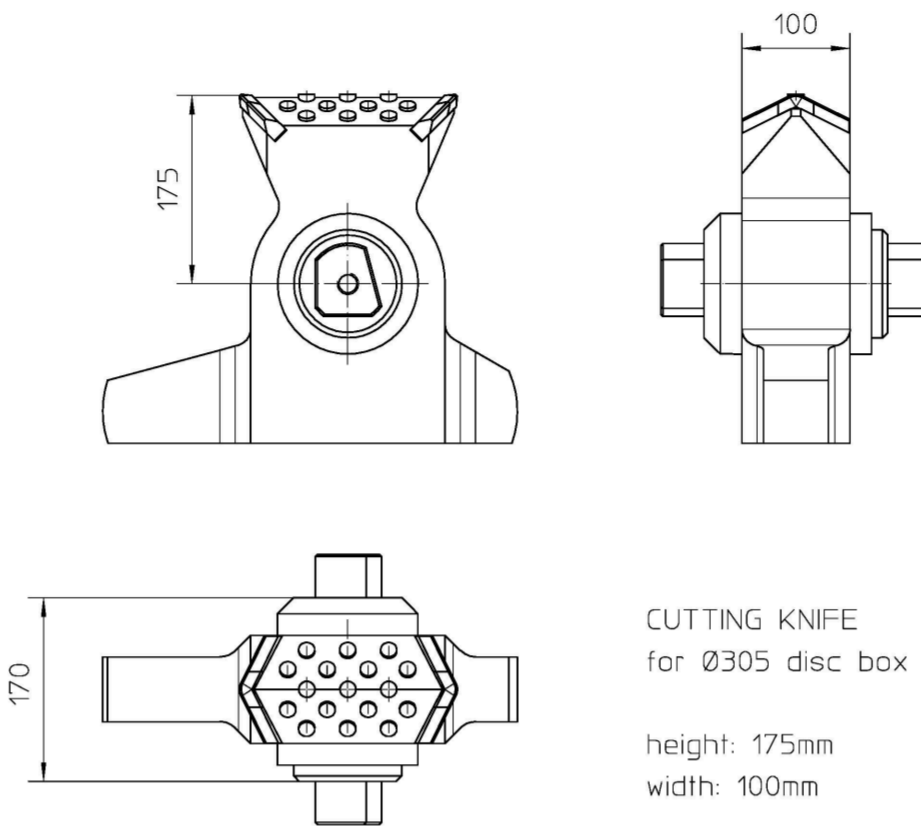

CUTTING KNIFE
for Ø305 disc box
height: 175mm
width: 100mm

Pos. 410

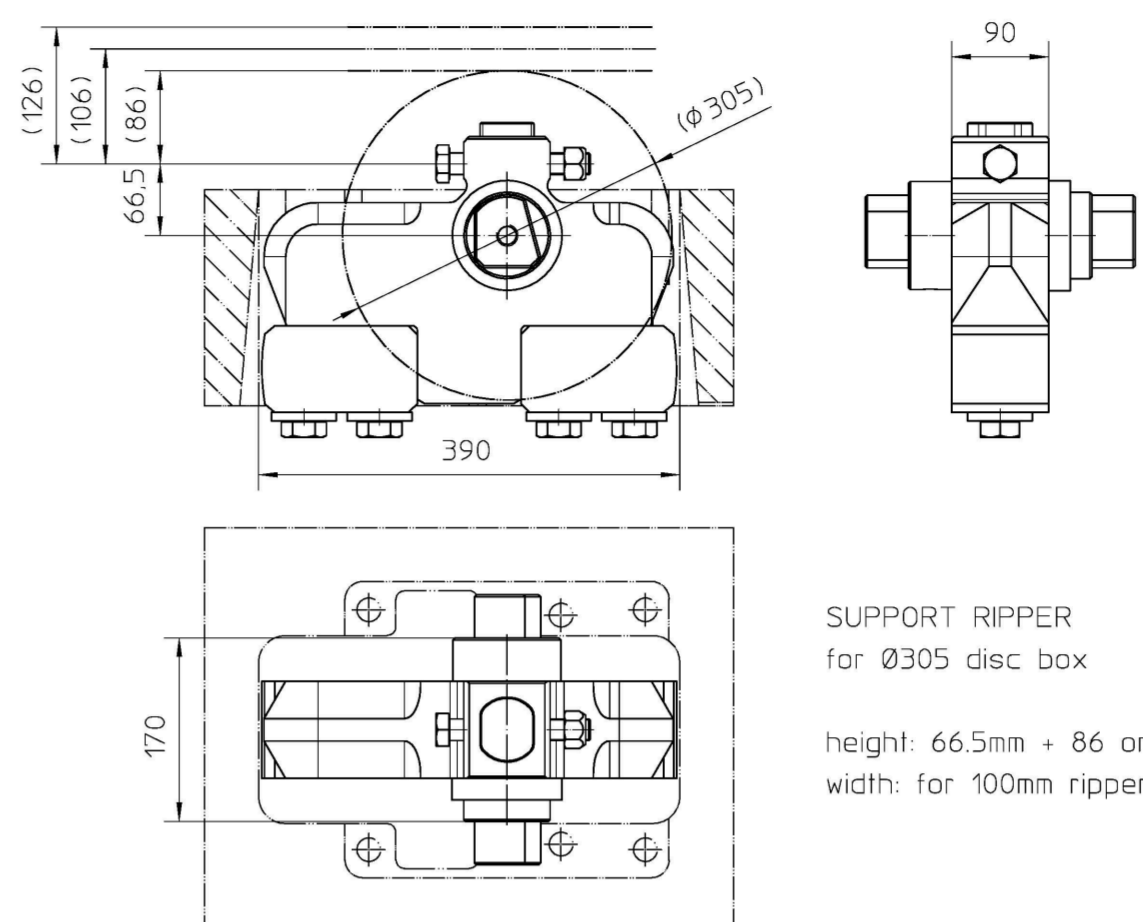

SUPPORT RIPPER
for Ø305 disc box
height: 66.5mm + 86 or 106 or 126
width: for 100mm ripper tool

Pos. 510

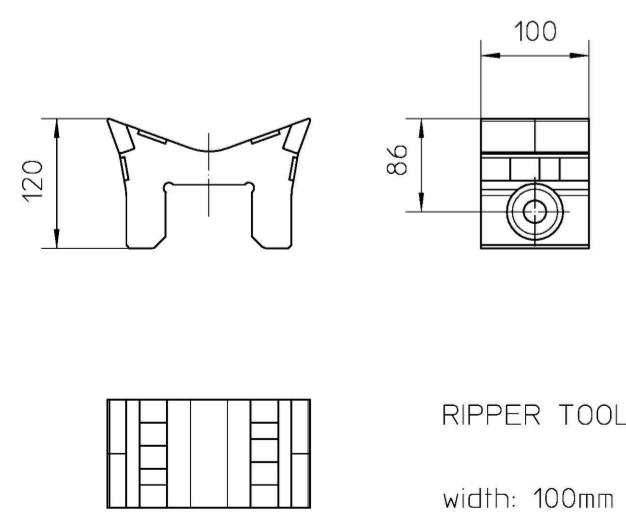

RIPPER TOOL
width: 100mm

Pos. 511

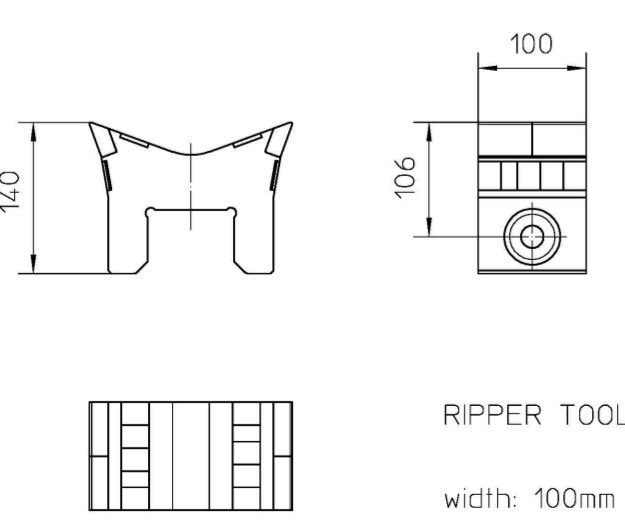

RIPPER TOOL
width: 100mm

Pos. 520

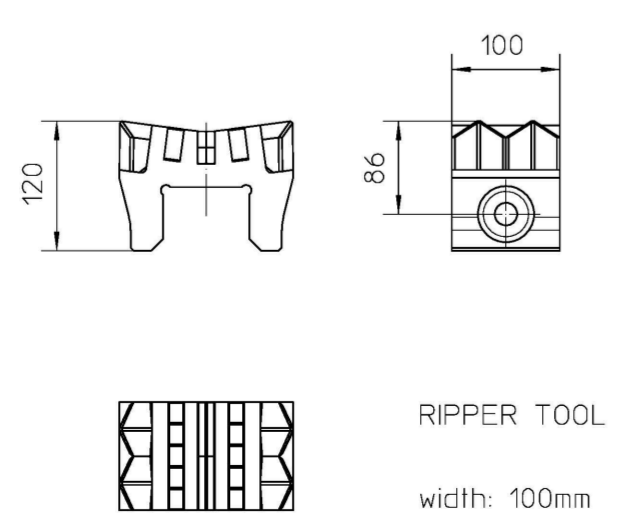

RIPPER TOOL
width: 100mm

Pos. 521

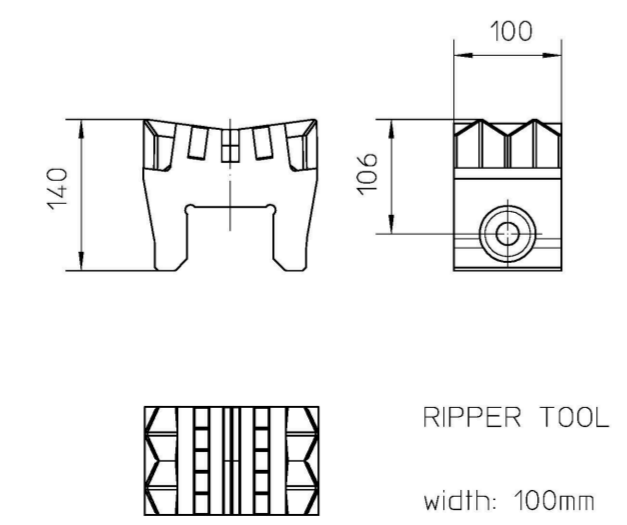

RIPPER TOOL
width: 100mm

Pos. 522

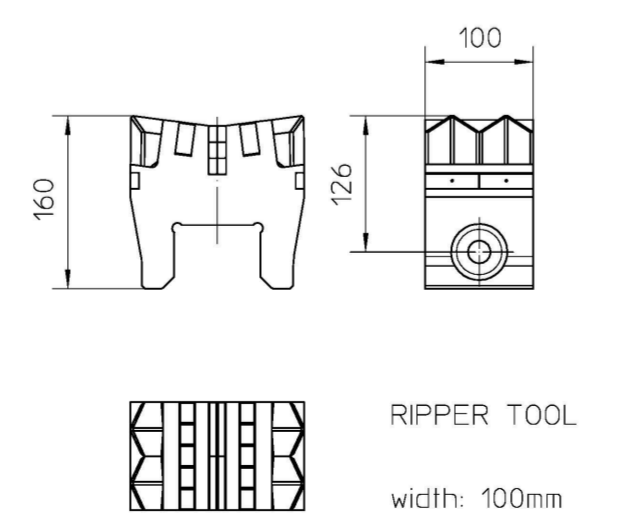

RIPPER TOOL
width: 100mm

Pos. 531

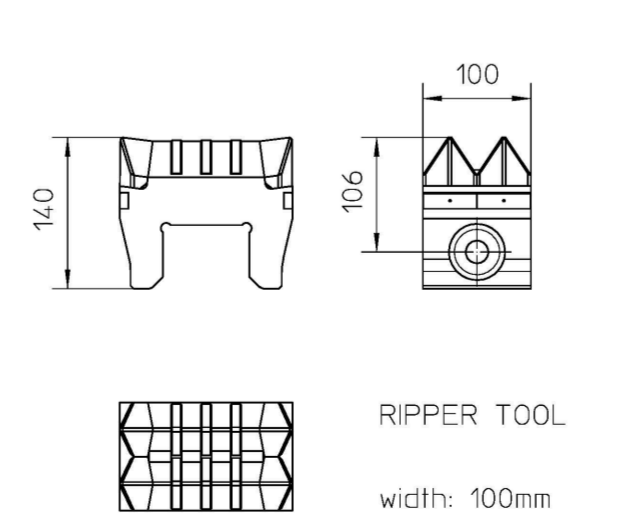

RIPPER TOOL
width: 100mm

Pos. 540

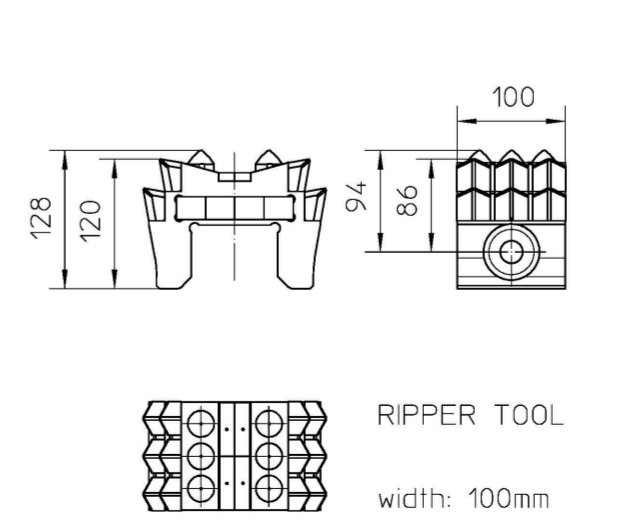

RIPPER TOOL
width: 100mm

Pos. 570

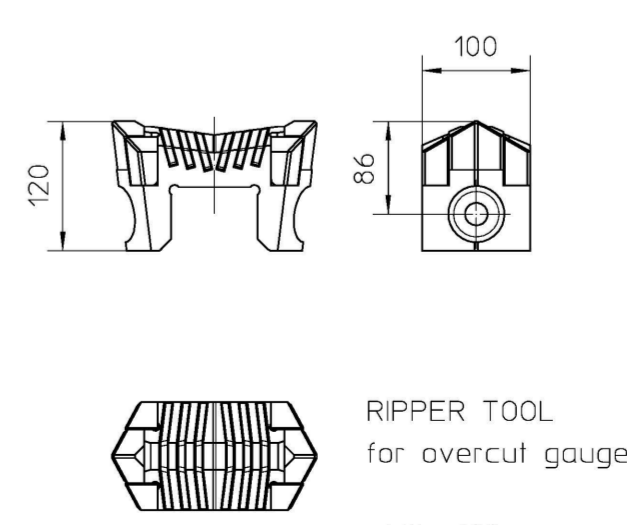

RIPPER TOOL
for overcut gauge area
width: 100mm

570	1	RIPPER TOOL B100H106-20/A80D60/2HZ6+M							40320865	9.1		
540	1	RIPPER TOOL B100H106-20/A80D60/2HZ+M2+P							40312945	9.7		
531	1	RIPPER TOOL B100H106/A80D60/HM+Z703HMS							40019827	7.9		
522	1	RIPPER TOOL B100H106+20/A80D60/HZ3+MS							40408384	15.4		
521	1	RIPPER TOOL B100H106/A80D60/HZ3HMS							40164064	12.4		
520	1	RIPPER TOOL B100H106-20/A80D60/HZ3+MS							40316243	9.9		
511	1	RIPPER TOOL B100/H106/A80D60/HMS2HM/CL							40263096	11		
510	1	RIPPER TOOL B100/H106-20/A80D60/HMS2HM/CL							40320908	8.6		
410	1	SUPPORT RIPPER H66.5/A80D60-M20/3R/HD/KL							40616842	59.5		
400	1	CUTTING KNIFE B100-DA305-R3-DISKENKASTEN							30013410	53.4		
350	1	DISC CUTTER D305/2SR-13S/S72/3R/PC/T							29603717	63.5		
300	1	DISC CUTTER D305/2SR-13S/S72/3R/T							29600969	63.5		
250	1	DISC CUTTER D305/2MB-13S/S72/3R/PC/T							40353719	62.5		
230	1	DISC CUTTER D305/2MB/TCL-HF/S72/3R/W10/T							40373522	66.5		
210	1	DISC CUTTER D305/2MB-13S/S72/3R/HF/W14/T							40517094	63		
200	1	DISC CUTTER D305/2MB-13S/S72/3R/W14/T							29604335	62.5		
Pos.	Qty.	Designation 1 Designation 2	Material Drawing no.	Material paper	Partname Dimension				Material- number	Weight kg/pc.		
P		Pos.410 durch 40618842 ersetzt, Pos.411 entfernt, Pos.531 war Pos.530							16.03.2022	zettwita	17.03.2022	malikd
O		Pos.210, 411, 530, 540 hinzu							04.10.2021	zettwita	23.11.2021	malikd
N		Pos.100, 150 entfernt, Pos.250, 522 hinzu, Pos.410 war 40386861							15.08.2019	schroiv	12.09.2019	malikd
Revision		Change							Date	Drawn	Date	Released
The reproduction, distribution and utilization of this document as well as the communication of its contents to others without express authorization is prohibited. Offenders will be held liable for the payment of damages. All rights reserved in the event of the grant of a patent, utility model or design. ISO 16016										General tolerances		
Edges of undefined shape										ISO 13715:2000		
Geometrical product specification										(GPS) EN ISO 1101:2013		
Surface specifications according to										EN ISO 1302:1992		
Drawing type										STANDARD-AVN		
Project										Machine type		
Name										DISC CUTTER BASIC		
Name										SCHNEIDROLLE BASIS		
Name										D305/S72/3R		
Drawing number										809-90-090-08		
Date										1/1		
Name										P		
Format										A2S1		
Scale										1:7		
Material no.										29600889		
Material										Weight/kg		
Projection										Projection		
Date										29.11.2010		
Name										Weiß Vitall		
Released										12.07.2013		
Name										Steiner, Thomas		

HERRENKNECHT
Tunnelling Systems
www.herrknecht.com

Sheet 1/1 Revision P Format A2S1

Drawn 29.11.2010 Weiß Vitall
Released 12.07.2013 Steiner, Thomas

Scale 1:7 Material no. 29600889

Baukastenstückliste modular BOM



Projekt
Material 29600889
Bezeichnung 1 SCHNEIDROLLE BASIS

Zchnng.Nr/ver 809-90-090-08 / P
Gewicht 67 KG
Werk 1000

project
material 29600889
description 1 DISC CUTTER BASIC

draw.No/ver 809-90-090-08 / P
weight 67 KG
plant

Pos.	Typ type	Material	Menge qty	Bezeichnung 1 / Bezeichnung 2	description 1 / description 2	Zchnng.Nr/ver/Bpf draw.No/ver	Gewicht weight
200	L	29604335	1,000 ST	SCHNEIDROLLE	DISC CUTTER	C1272-MB/F	62,50 KG
210	L	40517094	1,000 ST	SCHNEIDROLLE	DISC CUTTER	C1272-MB-HF/-	63,00 KG
230	L	40373522	1,000 ST	SCHNEIDROLLE	DISC CUTTER	C1272-MB-TCI/A	66,50 KG
250	L	40353719	1,000 ST	SCHNEIDROLLE	DISC CUTTER	C1272-MB-PC/A	62,50 KG
300	L	29600969	1,000 ST	SCHNEIDROLLE	DISC CUTTER	C1272/H	63,50 KG
350	L	29603717	1,000 ST	SCHNEIDROLLE	DISC CUTTER	C1272-PC/C	63,50 KG
400	L	30013410	1,000 ST	SCHÄLMESSER	CUTTING KNIFE	809-91-100-00/E	53,40 KG
410	L	40616842	1,000 ST	HALTER STICHEL	SUPPORT RIPPER	1501-305-041-000/-	59,50 KG
510	L	40320908	1,000 ST	STICHELKOPF	RIPPER TOOL	1503-100-100-080/A	8,60 KG
511	L	40263096	1,000 ST	STICHELKOPF	RIPPER TOOL	1503-100-100-063/A	11,00 KG
520	L	40316243	1,000 ST	STICHELKOPF	RIPPER TOOL	1503-100-100-071/-	9,90 KG
521	L	40164064	1,000 ST	STICHELKOPF	RIPPER TOOL	1503-100-100-033/-	12,40 KG
522	L	40408384	1,000 ST	STICHELKOPF	RIPPER TOOL	1503-100-100-091/-	15,40 KG
531	L	40019827	1,000 ST	STICHELKOPF	RIPPER TOOL	1503-100-001-330/-	7,90 KG
540	L	40312945	1,000 ST	STICHELKOPF	RIPPER TOOL	1503-100-001-580/-	9,70 KG
570	L	40320865	1,000 ST	STICHELKOPF	RIPPER TOOL	1503-100-100-074/-	9,10 KG