

A-A

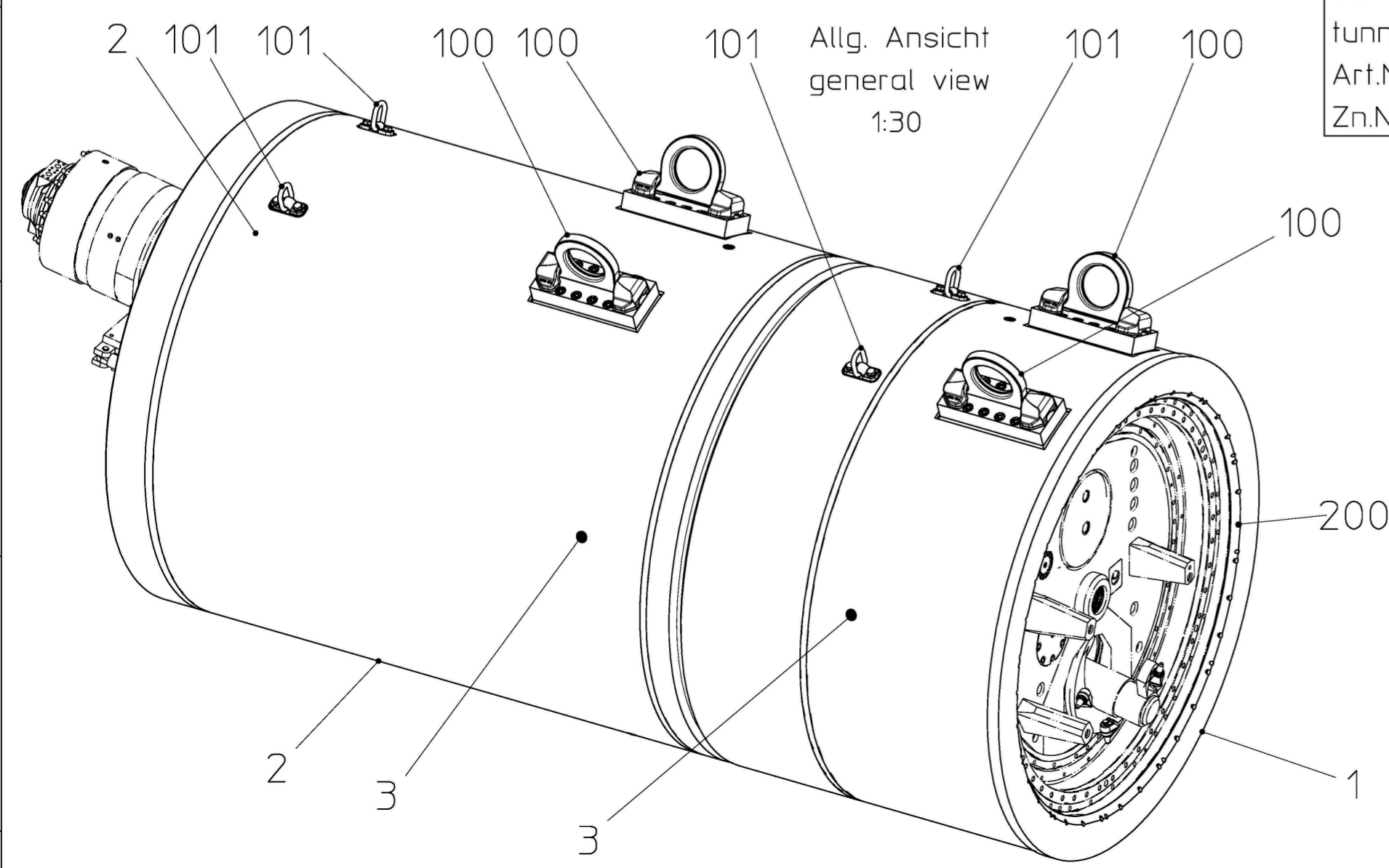
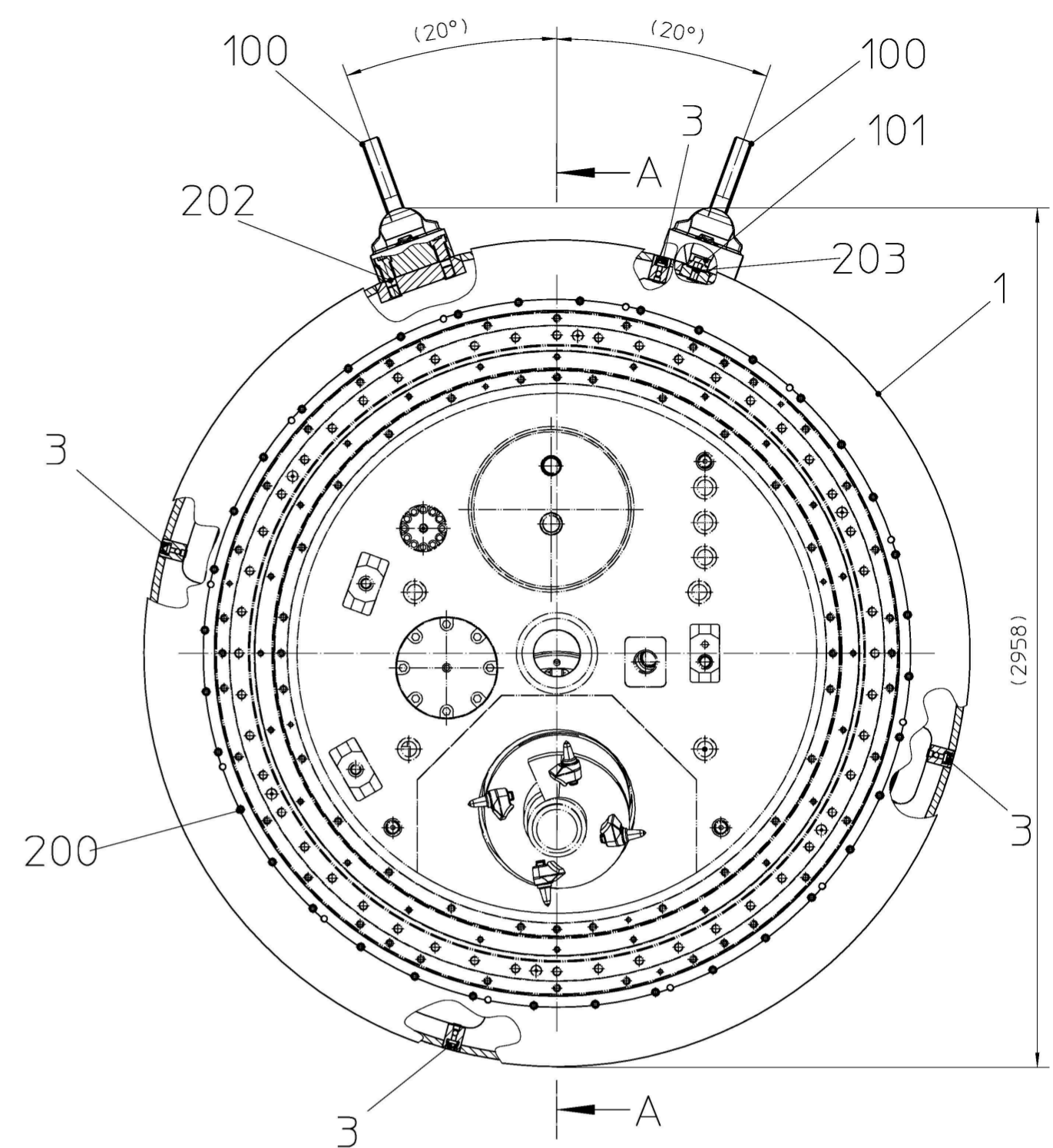
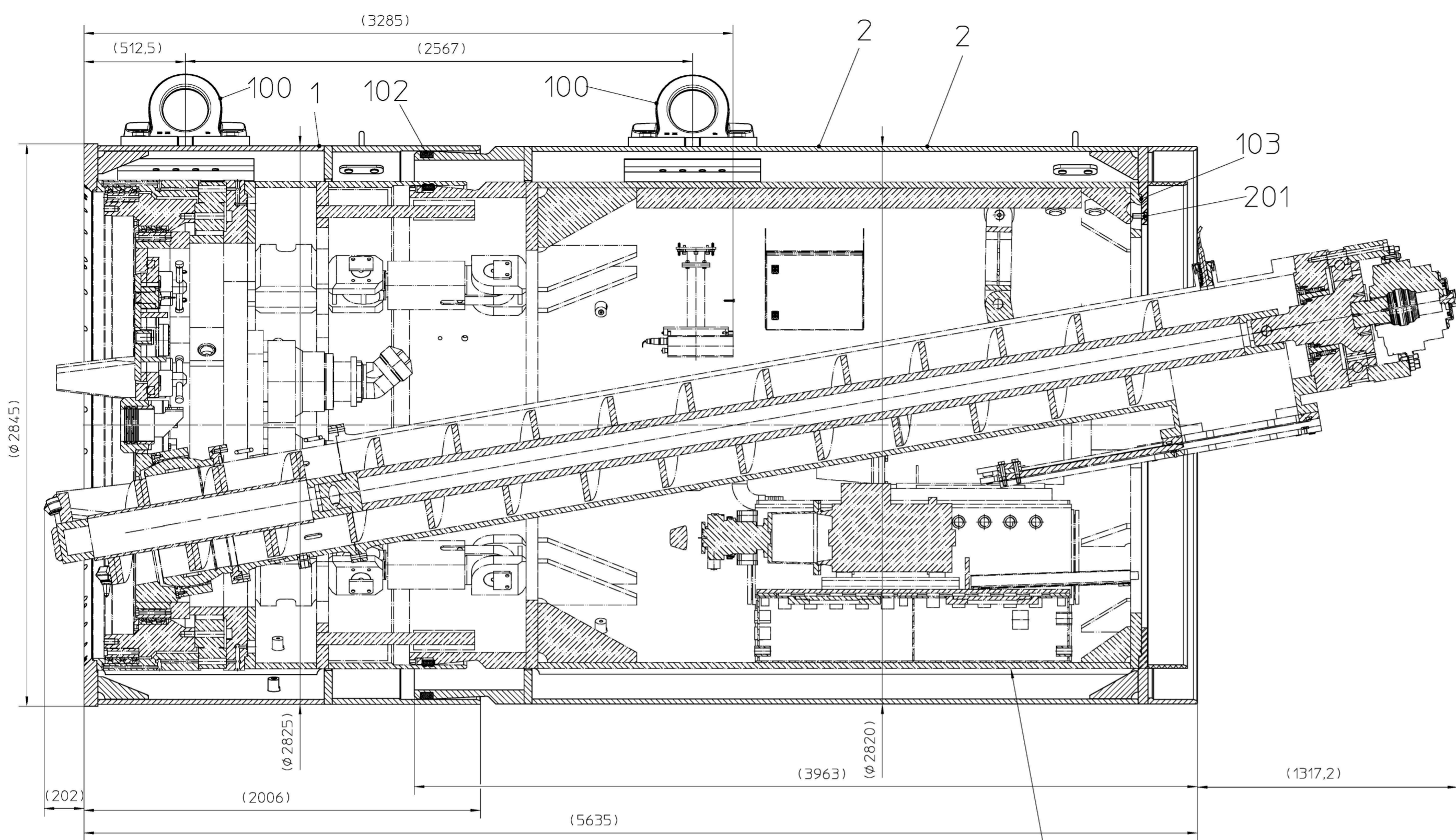

Vortriebsmaschine /
tunnelling machine
Art.Nr.: 30027594
Zn.Nr.: 1187-01-000-00

Allg. Ansicht
general view
1:30

Maschine/ machine	Vortriebsmaschine/ tunnelling machine	Gesamtgewicht/ total weight
	40000kg	55500kg
AD/ extension	15500kg	

Wenn nicht anderweitig angegeben, sind metrische Schafschrauben entsprechend den HERRENKNECHT-Anweisungen nach folgender Tabelle anzuziehen

Schrauben-Anzugsmomente in Nm

nach AA-HKAG-2.5-026
Reibungskoeffizient $\mu_{ges.} = 0,12$

If not defined otherwise, metric screws have to be tightened in accordance with the prescriptions from HERRENKNECHT in the following table

Screw tightening torques in Nm

according to AA-HKAG-2.5-026
coefficient of friction $\mu_{tot.} = 0,12$

	5.6	8.8	10.9	12.9
M16	85	180	265	310
M20	165	360	520	600
M36	980	2150	3100	3600
M42	1550	3450	4900	5800

Pos.500 Transportsituation Art.Nr.: 40619737

A Pos.500 hinzugefügt		28.04.2022	hurstk	28.04.2022	mannherz
Revision	Change	Date	Drawn	Date	Released
The reproduction, distribution and utilization of this document as well as the communication of its contents to others without express authorization is prohibited. Offenders will be held liable for the payment of damages. All rights reserved in the event of the grant of a patent, utility model or design. ISO 16016				General tolerances	
Edges of undefined shape		ISO 13715:2000		Drawing type assembly	
Geometrical product specification		(GPS) EN ISO 1101:2013		Machine type EPB2000T-01	
Surface specifications according to		EN ISO 1302:1992		Project M-722M	
 Tunnelling Systems www.herrenknecht.com					
Date		Name		Name	
02.03.2022		Hoffmann, Alex		UPSIZED SHELL AUFDOPPELMANTEL DA2825-VTRM	
08.04.2022		Mannherz, Daniel		Drawing number 1187-08-002-00	
Scale	Material no.	Material	Weight/kg	Sheet	Revision
1:20	40619013		15500	1/1	A
				Format	
				A2	
				Projection	

Baukastenstückliste modular BOM



Projekt
Material 40619013
Bezeichnung 1 AUFDOPPELMANTEL

Zchnng.Nr/ver 1187-08-002-00 / A
Gewicht 15.500 KG
Werk 1000

project
material 40619013
description 1 UPSIZE SHELL

draw.No/ver 1187-08-002-00 / A
weight 15.500 KG
plant

Pos.	Typ type	Material	Menge qty	Bezeichnung 1 / Bezeichnung 2	description 1 / description 2	Zchnng.Nr/ver/Bpf draw.No/ver	Gewicht weight
1	L	40619011	1,000 ST	AUFDOPPELMANTEL STAHLBAU	UPSIZESH SHELL STEEL STRUCTURE	1187-08-002-01/C	5.060,00 KG
2	L	40619012	1,000 ST	AUFDOPPELMANTEL STAHLBAU	UPSIZESH SHELL STEEL STRUCTURE	1187-08-005-01/-	9.330,00 KG
3	L	25102954	8,000 ST	BENTONITDÜSE	BENTONITE NOZZLE	809-01-040-00/F	1,60 KG
100	L	29502633	4,000 ST	ANSCHLAGPUNKT RINGBOCK	LIFTING POINT RING BRACKET		219,00 KG
101	L	29900016	4,000 ST	ANSCHLAGPUNKT	LIFTING POINT		3,32 KG
102	L	28100781	1,000 ST	DICHTUNGSPROFILRING	SEALING PROFILE RING		20,00 KG
103	Z	28201780	1,000 ST	RUNDSCHNUR ENDLOS	ROUND CORD ENDLESS		0,41 KG
200	L	24000359	36,000 ST	ZYLINDERSCHRAUBE M16X55-10.9-DIN912	HEX.SOCKET HEAD CAP SCREW M16X55-10.9-DIN912		0,09 KG
201	L	24005636	24,000 ST	ZYLINDERSCHRAUBE GVZ M24X60-8.8-DIN6912	HEX.SOCKET HEAD CAP SCREW ZP M24X60-8.8-DIN6912		0,26 KG
202	L	24007235	32,000 ST	VERSCHLUSSSCHRAUBE M36X4-5.8-DIN906	PLUG SCREW M36X4-5.8-DIN906		0,07 KG
203	L	24007218	8,000 ST	VERSCHLUSSSCHRAUBE M27X3-5.8-DIN906	PLUG SCREW M27X3-5.8-DIN906		30,00 G
500	L	40619737	1,000 ST	TRANSPORTSITUATION	TRANSPORT SITUATION	1187-08-002-90/A	922,04 KG

* Z = Infoteil
* Z = reference part