

+1.001-003.T4
shield

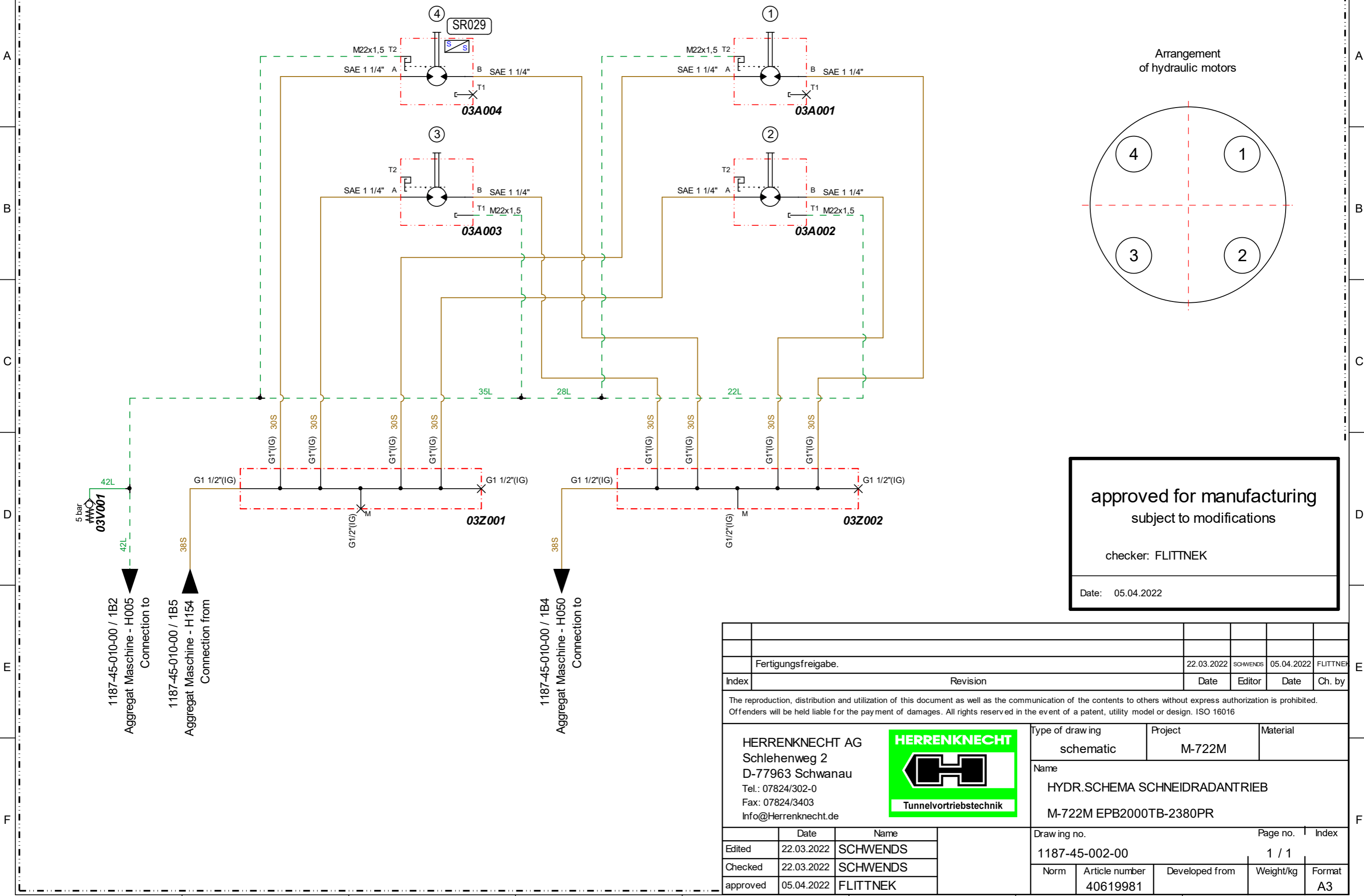

Arrangement of hydraulic motors

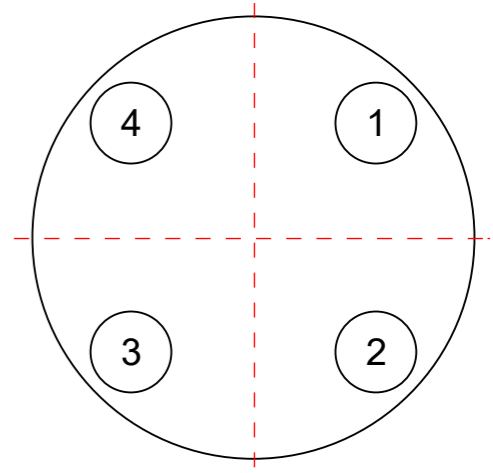

approved for manufacturing
subject to modifications

checker: FLITTNEK

Date: 05.04.2022

Fertigungsfreigabe.		22.03.2022	SCHWENDS	05.04.2022	FLITTNEK
Index	Revision			Date	Editor
The reproduction, distribution and utilization of this document as well as the communication of the contents to others without express authorization is prohibited. Offenders will be held liable for the payment of damages. All rights reserved in the event of a patent, utility model or design. ISO 16016					
HERRENKNECHT AG Schlehenweg 2 D-77963 Schwanau Tel.: 07824/302-0 Fax: 07824/3403 Info@Herrenknecht.de		 Tunnelvortriebstechnik		Type of drawing schematic	Project M-722M
Name HYDR.SCHEMA SCHNEIDRADANTRIEB M-722M EPB2000TB-2380PR		Material			
Date 22.03.2022		Name SCHWENDS		Draw ing no. 1187-45-002-00	Page no. 1 / 1
Checked 22.03.2022		Name SCHWENDS		Norm	Article number 40619981
approved 05.04.2022		Name FLITTNEK		Developed from	Weight/kg
				Format A3	

09.09.2022
[Structure]

Strukturstückliste Modular parts list



Projekt
Teilenummer 40619981
HYDR.SCHEMA SCHNEIDRADANTRIEB
Zeichnungsnr. 1187-45-002-00

Project
Part number 40619981
HYDR.DIAGR.CUTTING WHEEL DRIVE
Drawing no. 1187-45-002-00

Item	Operating resources structure	Document path	Material number	description	Designation	Drawing no.	Quantity
1	03A001	1A5	23500958	AXIALKOLBEN-KONSTANTMOTOR	AXIAL PISTON CONSTANT MOTOR		1,00 ST
2	03A002	1B5	23500958	AXIALKOLBEN-KONSTANTMOTOR	AXIAL PISTON CONSTANT MOTOR		1,00 ST
3	03A003	1B3	23500958	AXIALKOLBEN-KONSTANTMOTOR	AXIAL PISTON CONSTANT MOTOR		1,00 ST
4	03A004	1A3	23501788	AXIALKOLBEN-KONSTANTMOTOR	AXIAL PISTON CONSTANT MOTOR		1,00 ST
6	03V001	1D1	27103859	RÜCKSCHLAGVENTIL	CHECK VALVE	RHD42L5BOMDCF	1,00 ST
7	03Z001	1D3	25631471	VERTEILERBLOCK	DISTRIBUTOR BLOCK	208-10-004-02 F	1,00 ST
7.1	Z1		12430090	VIERKANTSTAHL WARMGEWALZT	SQUARE STEEL BAR, HOT-ROLLED		0,45 M
8	03Z002	1D5	25631471	VERTEILERBLOCK	DISTRIBUTOR BLOCK	208-10-004-02 F	1,00 ST
8.1	Z1		12430090	VIERKANTSTAHL WARMGEWALZT	SQUARE STEEL BAR, HOT-ROLLED		0,45 M