

+1.001-005.T4
machine can 1

screw conveyor drive

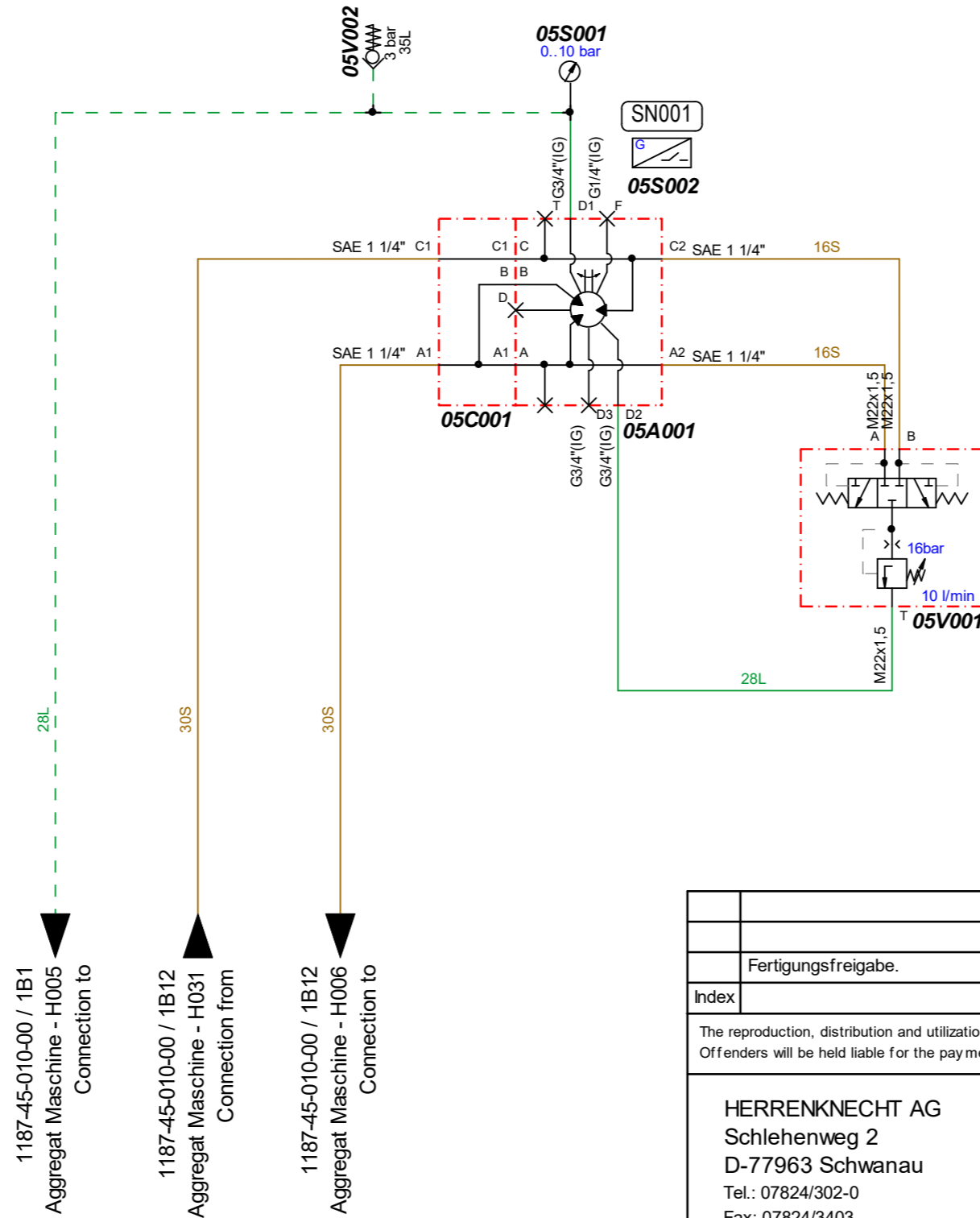

1187-45-010-00 / 1B1
Aggregat Maschine - H005
Connection to

1187-45-010-00 / 1B12
Aggregat Maschine - H031
Connection from

1187-45-010-00 / 1B12
Aggregat Maschine - H006
Connection to

approved for manufacturing
subject to modifications

checker: FLITTNEK

Date: 05.04.2022

Fertigungsfreigabe.		22.03.2022	SCHWENDS	05.04.2022	FLITTNEK
Index	Revision	Date	Editor	Date	Ch. by
The reproduction, distribution and utilization of this document as well as the communication of the contents to others without express authorization is prohibited. Offenders will be held liable for the payment of damages. All rights reserved in the event of a patent, utility model or design. ISO 16016					
HERRENKNECHT AG Schlehenweg 2 D-77963 Schwanau Tel.: 07824/302-0 Fax: 07824/3403 Info@Herrenknecht.de		 Tunnelvortriebstechnik		Type of drawing schematic	Project M-722M
				Material	
Name HYDR.SCHEMA SCHNECKENANTRIEB M-722M EPB2000TB-2380PR					
Date		Name		Draw ing no.	Page no. Index
Edited	22.03.2022	SCHWENDS		1187-45-003-00	1 / 1
Checked	22.03.2022	SCHWENDS			
approved	05.04.2022	FLITTNEK		Norm	Article number
				40619982	Developed from
					Weight/kg
					Format
					A3

09.09.2022
[Structure]

Strukturstückliste Modular parts list



Projekt
Teilenummer 40619982
HYDR.SCHEMA SCHNECKENANTRIEB
Zeichnungsnr. 1187-45-003-00

Project
Part number 40619982
HYDR.DIAG.SCREW CONVEYOR DRIVE
Drawing no. 1187-45-003-00

Item	Operating resources structure	Document path	Material number	description	Designation	Drawing no.	Quantity
1	05A001	1C4	23100113	HYDRAULIKMOTOR	HYDRAULIC MOTOR	23100113	1,00 ST
2	05C001	1C4	27201365	ADAPTERPLATTE HYDRAULIK	ADAPTER PLATE HYDRAULIC	27201365	1,00 ST
3	05S001	1B4	27500023	MANOMETER	PRESSURE GAUGE	27500023	1,00 ST
4	05S002	1B4	26600104	NÄHERUNGSSCHALTER	PROXIMITY SWITCH	26600104	1,00 ST
5	05V001	1D5	27101822	SPÜLVENTIL	FLUSHING VALVE	27101822	1,00 ST
6	05V002	1B4	27103853	RÜCKSCHLAGVENTIL	CHECK VALVE	RHD35L3BOMDCF	1,00 ST