

**Cliente** : Indumix SIF 2 sensores cemento  
**Desig. instalación:** Silo Fijo 2H  
**Nº de dibujo** : 13-007  
**Referencia** : SI00757



**Fabricante (empresa)** : INDUMIX Argentina SA  
 : Av. Malvinas 450  
 :

**Producto** : 13-009  
**Tipo** :  
**Lugar de montaje** : xxxxxxxx  
**Responsable de proyecto** : EGC  
**Particulari. Piezas** : Indumovil Silo Fijo

**Creado el** : 01.12.10

**Nº de página máxima** : 7

**Elaborado el** : 10.07.13 por (abrev.): EGC

**Cantidad de paginas** : 7



**INDUMIX S. A.**  
 Av. Las Malvinas 450  
 (5125) Monte Cristo - Córdoba  
 República Argentina  
 Tel.: (54-351) 4917614  
 e-mail: info@indumix.net

**Dibujante:** EGC

**REVISION**

**Fecha:** 10.07.13

1

**Visto:** 14.07.11

2

**EGACOM SRL**

3

**Título:** Caratula

**Dibujo Nº:** 13-007

**Referencia Nº:** SI00757

**Cliente:** Indumix SIF 2 sensores cemen

**Máquina:** Silo Fijo 2H

**Página**  
**Nº:**

1

**Página**  
**sig. Nº:**

2

# Indice de páginas

Coloca "x" a una pagina automática que ha sido manualmente modificada

Pagina	Design. pagina	Fecha	Elab.	X
1	Øaratula	30.07.13	EGC	5
2	Indice de paginas	22.08.19	EGC	X
3	Generales	22.08.19	EGC	
4	TOPOGRAFICO TABLERO	22.08.19	EGC	
5	Listado de Cables	08.08.19	PC1	
6	Conexion de Bornes X2	08.08.19	PC1	
7	LISTADO DE MATERIALES	08.08.19	EGC	



**INDUMIX S. A.**  
 Av. Las Malvinas 450  
 (5125) Monte Cristo - Córdoba  
 República Argentina  
 Tel. : (54-351) 4917614  
 e-mail: info@indumix.net

Dibujante: EGC	REVISION
Fecha: 22.08.19	1
Visto: 14.07.11	2
EGACOM SRL	3

Titulo: Indice de paginas  
 Dibujo N°: 13-007  
 Referencia N°: SI00757

Cliente: Indumix SIF 2 sensores cemen  
 Máquina: Silo Fijo 2H

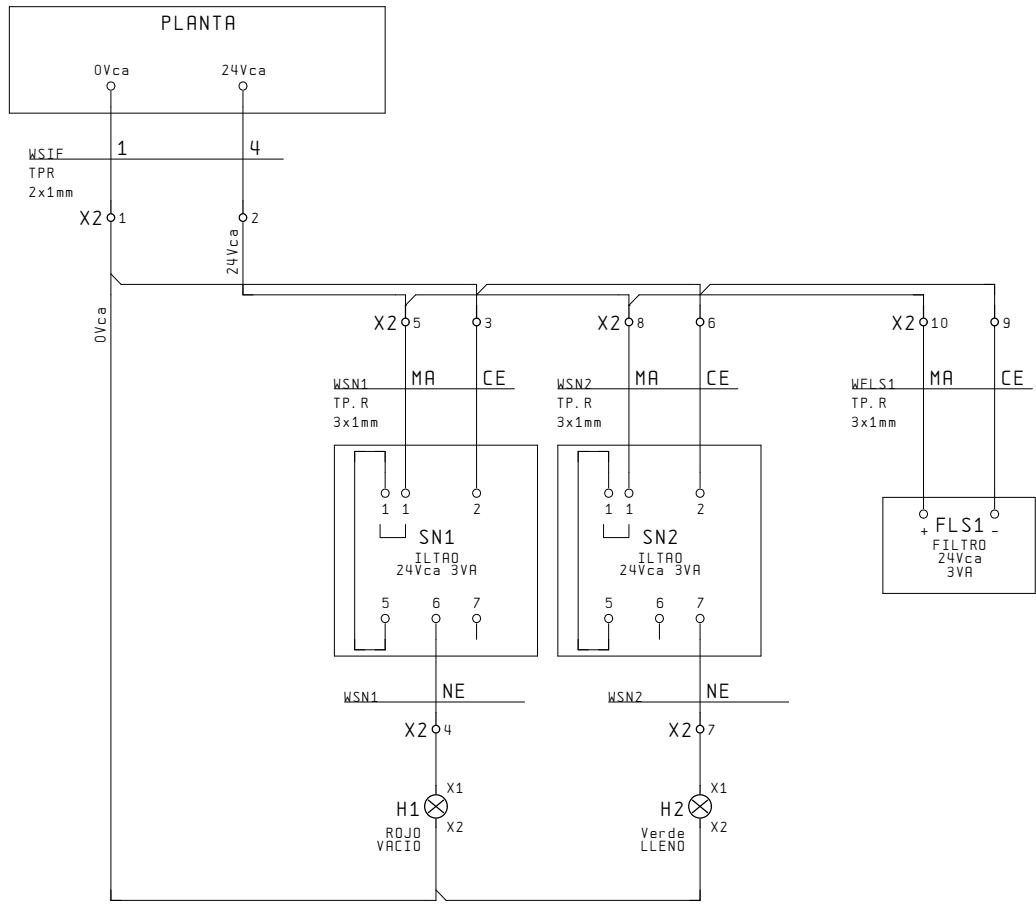

Lampara Tolva Vacia  
Lamp empty hopper

Lampara Tolva Llena  
Lamp full hopper

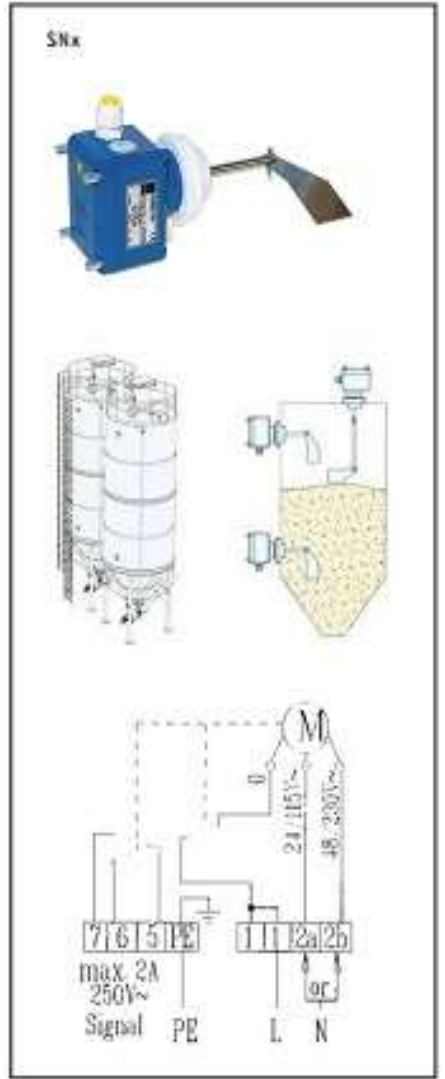

**INDUMIX S. A.**  
Av. Las Malvinas 450  
(5125) Monte Cristo - Córdoba  
República Argentina  
Tel.: (54-351) 4917614  
e-mail: info@indumix.net

Dibujante: EGC	REVISION
Fecha: 22.08.19	1
Visto: 23.07.13	2
EGACOM SRL	3

Título: Generales

Dibujo N°: 13-007

Referencia N°: SI00757

Cliente: Indumix SIF 2 sensores cemen

Máquina: Silo Fijo 2H

E

D

C

B

A

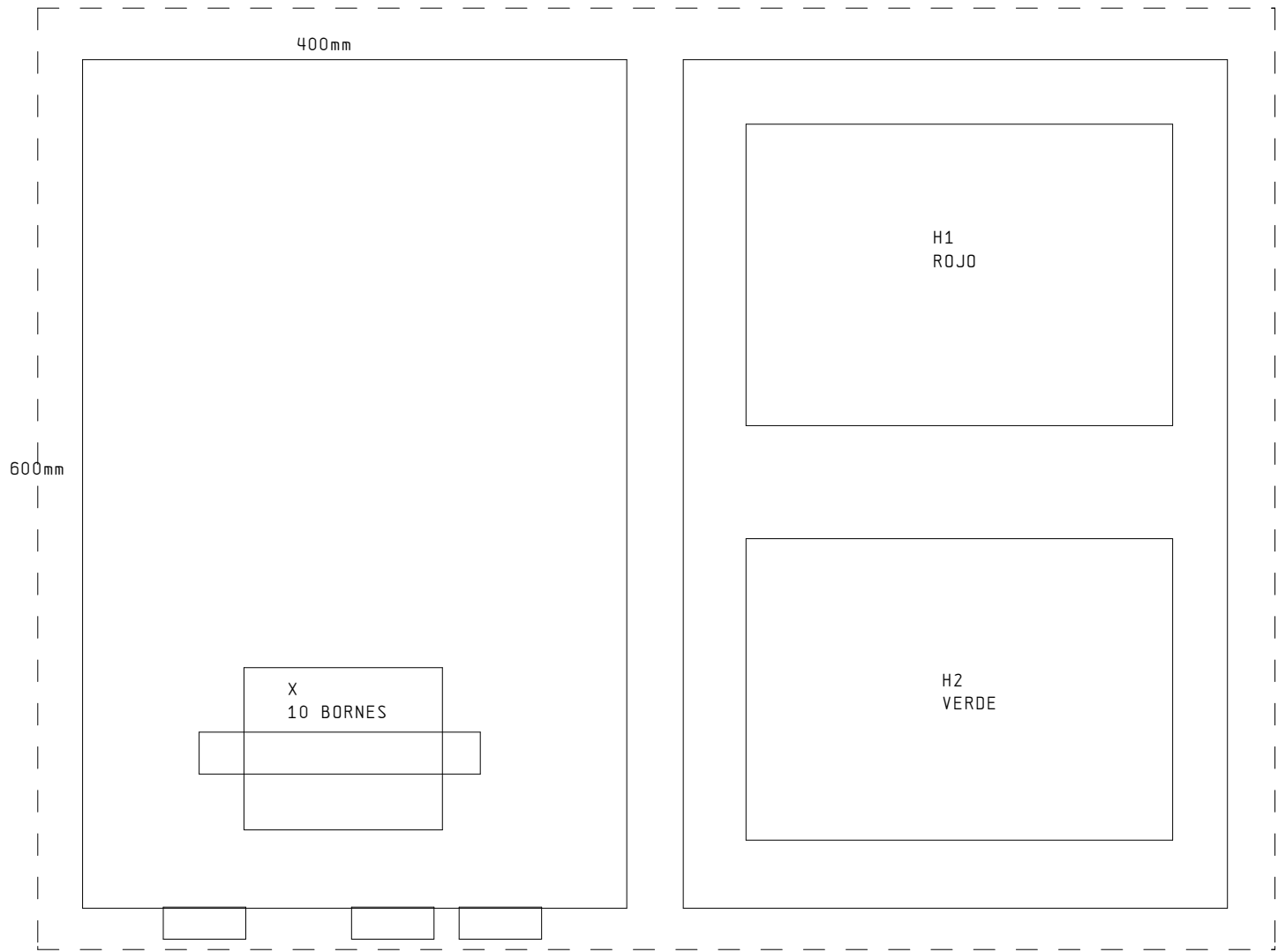

**INDUMIX S. A.**  
 Av. Las Malvinas 450  
 (5125) Monte Cristo - Córdoba  
 República Argentina  
 Tel.: (54-351) 4917614  
 e-mail: info@indumix.net

Dibujante: EGC	REVISION
Fecha: 22.08.19	1
Visto: 23.07.13	2
EGACOM SRL	3

Titulo: TOPOGRAFICO TABLERO	Cliente: Indumix SIF 2 sensores cemen
Dibujo N°: 13-007	Máquina: Silo Fijo 2H
Referencia N°: SI00757	

Página	4
Página sig. N°:	5

# Resumen de cables

WUPS001 22.04.96

Nombre cable		Origen	Dest.	Tipo de cable	Cond.	utilizado Cond.	Sección mm <sup>2</sup>	Long. m	Observación	Gráfico - Pagina
Design. de cable	de	hasta								
WFLS1	X2	FLS1		TP. R	3	2	1	-		
WSIF				TPR	2	2	1	-		
	X2	0Vca			2	1	1			
	X2	24Vca			2	1	1			
WSN1	X2	SN1		TP. R	3	3	1	-		
WSN2	X2	SN2		TP. R	3	3	1	-		
WH1	X2	H1		TPR	3	1	1	-		



INDUMIX S. A.  
 Av. Las Malvinas 450  
 (5125) Monte Cristo - Córdoba  
 República Argentina  
 Tel.: (54-351) 4917614  
 e-mail: info@indumix.net

Dibujante: PC1	REVISION
Fecha: 08.08.19	1
Visto: 08.08.19	2
EGACOM SRL	3

Título: Listado de Cables  
 Dibujo Nº: 13-007  
 Referencia Nº: SI00757

Cliente: Indumix SIF 2 sensores cemento  
 Máquina: Silo Fijo 2H

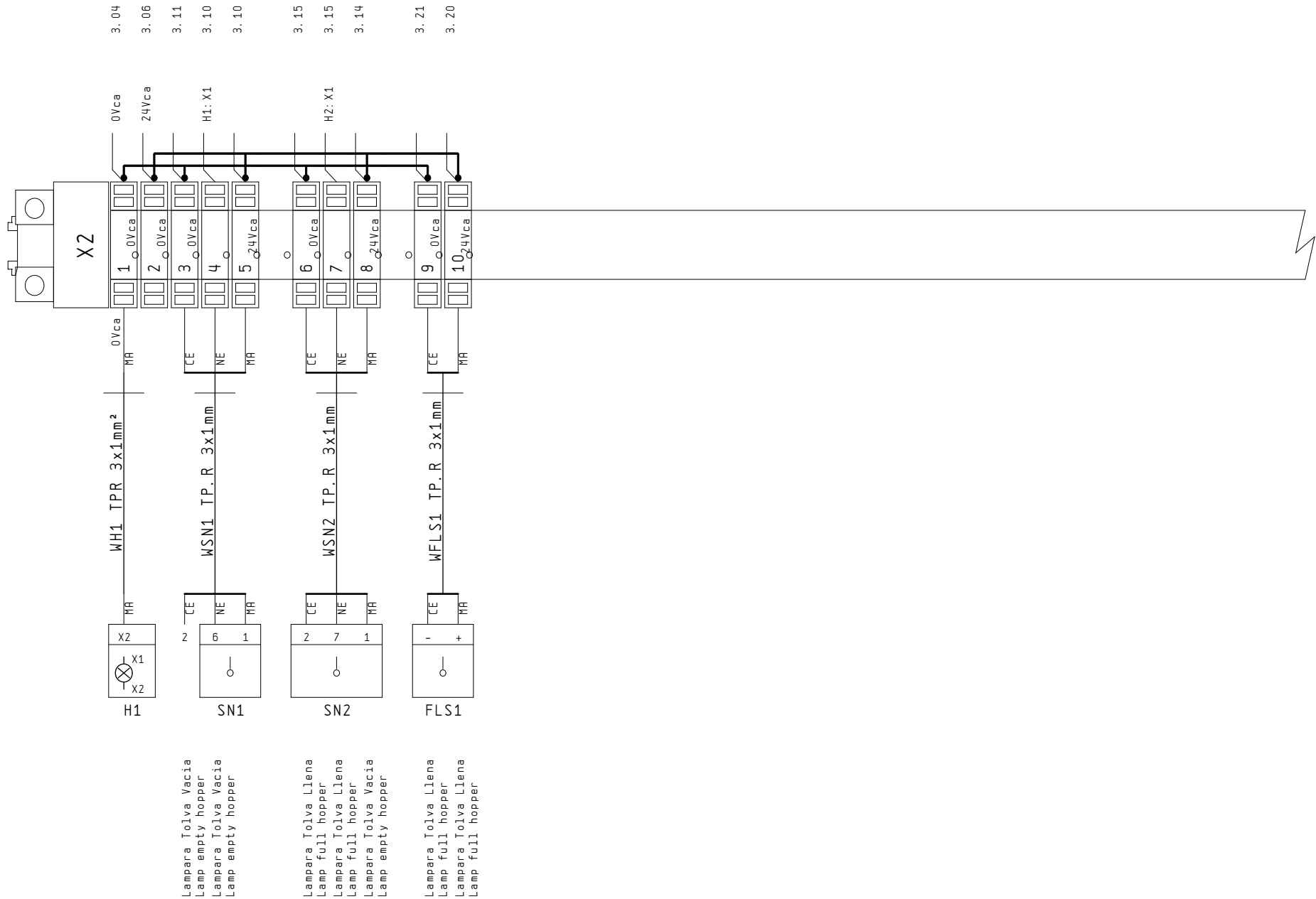

INDUMIX S. A.  
 Av. Las Malvinas 450  
 (5125) Monte Cristo - Córdoba  
 República Argentina  
 Tel.: (54-351) 4917614  
 e-mail: info@indumix.net

Dibujante: PC1	REVISION
Fecha: 08.08.19	1
Visto: 08.08.19	2
EGACOM SRL	3

Título: Conexion de Bornes X2
Dibujo No: 13-007
Referencia No: SI00757

Cliente: Indumix SIF 2 sensores cemento
Máquina: Silo Fijo 2H

