

JOHN DEERE

OPERATOR'S MANUAL

317 and 320
Skid Steer

OMT205050 ISSUE C9 (ENGLISH)



Introduction

Conformity Marking

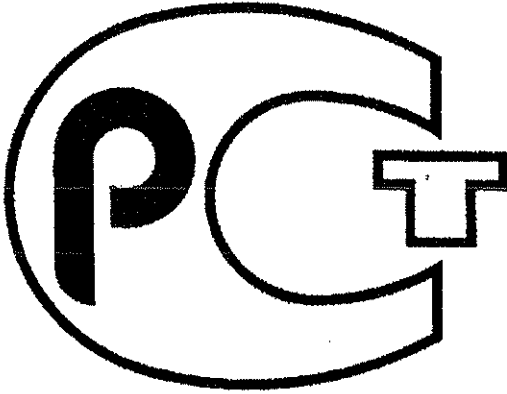

MP04

Russian Conformity Symbol

TX1051868 —LUN—21NOV08

NOTE: Some or all machine models listed on the front cover of this manual are available in optional factory configurations that meet or exceed Russian conformity requirements. To validate conformance

of a particular machine for sale into Russian markets, see your authorized dealer.

VD76477,00004A0 -19-24FEB09-1/1

Introduction

Technical Information Feedback Form

We need customer feedback to continually improve our technical publications. Please copy this page and FAX or mail your comments, ideas, and improvements.

SEND TO: John Deere Dubuque Works
P.O. Box 538
Attn: Publications Supervisor, Dept. 309
Dubuque, IA 52004-0538

FAX NUMBER: 563-589-5800

Ideas, Comments (Please State Page Number): _____

OVERALL, how would you rate the quality of this publication? (Check one)

	Poor		Fair		Good		Very Good		Excellent	
1	2	3	4	5	6	7	8	9	10	

Company Name: _____
Technician Name: _____
Address: _____
Phone: _____
Fax No.: _____
Dealer Acct. No.: _____

THANK YOU!

TX17994,000020B -19-10APR07-1/1

Introduction

Contents

Page	Page
Safety—Safety and Operator Conveniences	
Safety and Operator Convenience Features	1-1-1
Safety—General Precautions	
Recognize Safety Information	1-2-1
Follow Safety Instructions.....	1-2-1
Operate Only If Qualified.....	1-2-1
Wear Protective Equipment.....	1-2-2
Avoid Unauthorized Machine Modifications.....	1-2-2
Inspect Machine	1-2-2
Stay Clear of Moving Parts.....	1-2-2
Avoid High-Pressure Fluids	1-2-3
Avoid High-Pressure Oils	1-2-3
Beware of Exhaust Fumes	1-2-3
Prevent Fires	1-2-4
Prevent Battery Explosions	1-2-4
Handle Chemical Products Safely	1-2-4
Dispose of Waste Properly	1-2-5
Prepare for Emergencies.....	1-2-5
Safety—Operating Precautions	
Use Steps and Handholds Correctly	1-3-1
Start Only From Operator's Seat.....	1-3-1
Use and Maintain Seat Belt	1-3-1
Prevent Unintended Machine Movement	1-3-1
Avoid Work Site Hazards.....	1-3-2
Keep Riders Off Machine	1-3-2
Avoid Backover Accidents	1-3-3
Avoid Machine Tip Over	1-3-3
Operating or Traveling On Public Roads	1-3-3
Add and Operate Attachments Safely	1-3-4
Safety—Maintenance Precautions	
Park and Prepare for Service Safely	1-4-1
Service Tires Safely.....	1-4-1
Service Cooling System Safely	1-4-2
Remove Paint Before Welding or Heating.....	1-4-2
Make Welding Repairs Safely	1-4-2
Drive Metal Pins Safely	1-4-2
Safety—Safety Signs	
Safety Signs	1-5-1
Operation—Operator's Station	
Pedals and Levers - Standard Controls.....	2-1-1
Instrument Panel—EH Controls Machine.....	2-1-1
Instrument Panel Functions—EH	
Controls Machine	2-1-2
Engagement and Monitor Unit Operation	2-1-3
Anti-Theft Security System Operation	2-1-5
Engagement and Monitor Unit Data Items	2-1-7
Reading Engagement and Monitor Unit	
Diagnostic Trouble Codes	2-1-7
Gauges and Indicator Lights —	
Hands-Only and Hand-Foot Machines.....	2-1-8
Gauge and Indicator Light Functions	
— Hands-Only and Hand-Foot Machines	2-1-8
Auto Shutdown With Alarm.....	2-1-9
Horn Button—If Equipped.....	2-1-9
12-Volt Power Outlet.....	2-1-9
Dome Light	2-1-10
Heating/Defrosting Controls—If Equipped.....	2-1-10
Air Conditioning Controls—If Equipped	2-1-10
Rear Window (Secondary Exit)	2-1-11
Seat Adjustment	2-1-11
Suspension Seat Adjustment—If Equipped.....	2-1-11
Adjusting Armrests - Hands Only and	
Hand-Foot Machines.....	2-1-12
Beacon—If Equipped.....	2-1-12
Operation—Operating the Machine	
Before Starting Work	2-2-1
Operator's Daily Machine Check	
Before Starting	2-2-1
Entering Skid Steer.....	2-2-1
Starting the Engine	2-2-2
Cold Weather Starting	2-2-2
Engine Block Heater—If Equipped	2-2-3
Diesel Fired Coolant Heater	
Operation—If Equipped.....	2-2-4
Engine Warm-Up	2-2-4
Self-Leveling—If Equipped	2-2-4
Using Attachment Mounting	
System—Quik-Tatch™	2-2-5
Boom Lock.....	2-2-6
Boom Release—Standard Controls	2-2-7
Steering Levers—Hands Only and	
Hand-Foot Machines.....	2-2-7
Operating Auxiliary Hydraulics—Hand-	
Foot Machines.....	2-2-8
Operating Boom—Hand-Foot Machines	2-2-9
Operating Bucket—Hand-Foot Machines.....	2-2-10

Continued on next page

All information, illustrations and specifications in this manual are based on the latest information available at the time of publication. The right is reserved to make changes at any time without notice.

COPYRIGHT © 2009
DEERE & COMPANY
Moline, Illinois
All rights reserved.
A John Deere ILLUSTRATION © Manual
Previous Editions
Copyright © 2004, 2005, 2006, 2007, 2008

Contents

Page	Page
Operating Auxiliary Hydraulics—Hands Only Machines2-2-11	Clean Radiator and Oil Cooler.....3-3-2
Operating Boom and Bucket—Hands Only Machines2-2-11	Check Radiator Coolant Level.....3-3-2
Using Attachment Mounting System—Hydraulic Quik-Tatch (S.N. — 131876)2-2-12	Drain Fuel Water Separator Filter.....3-3-3
Using Attachment Mounting System—Electric Quik-Tatch (S.N. 131877 —)2-2-13	Check Auxiliary Water Separator Fuel Filter—If Equipped3-3-3
Stopping the Engine2-2-13	Maintenance—Every 50 Hours
Loading Machine On a Trailer2-2-14	Lubricate Boom Linkage, Cylinder Pivots, and Quik-Tatch™3-4-1
Maintenance—Machine	Check Tire Pressure3-4-2
Diesel Fuel.....3-1-1	Maintenance—Every 250 Hours
Biodiesel Fuel.....3-1-2	Check Wheel Lug Nut Torque.....3-5-1
Low Sulfur Diesel Fuel Conditioner3-1-3	Change Engine Oil and Replace Filter3-5-2
Testing Diesel Fuel3-1-3	Maintenance—Every 500 Hours
Handling and Storing Diesel Fuel.....3-1-3	Replace In-Line Fuel Filter3-6-1
Alternative and Synthetic Lubricants3-1-3	Replace Fuel Water Separator Filter3-6-1
Diesel Engine Oil.....3-1-4	Bleed Fuel System3-6-1
Diesel Engine Oil and Filter Service Intervals ...3-1-5	Replace Primary Air Cleaner Element.....3-6-2
Hydraulic and Hydrostatic Oil3-1-6	Replace Hydraulic Oil Tank Breather Element ...3-6-2
Chain Case Oil3-1-6	Replace Hydraulic Oil Filter3-6-3
Grease.....3-1-7	Check Chain Case Oil Level.....3-6-3
Light Duty Diesel Engine Coolant (for diesel engines without wet sleeve cylinder liners).....3-1-8	Check Battery Electrolyte Level and Terminals.....3-6-4
Drain Intervals for Diesel Engine Coolant.....3-1-9	Change Engine Oil and Replace Filter3-6-5
John Deere COOL-GARD™ II COOLANT EXTENDER3-1-9	Replace Auxiliary Water Separator Fuel Filter—If Equipped3-6-6
Supplemental Coolant Additives.....3-1-10	Lubricate Steering Linkage.....3-6-6
Operating in Warm Temperature Climates3-1-10	Lubricate Foot Pedal3-6-7
Additional Information About Diesel Engine Coolants and John Deere COOL-GARD™ II COOLANT EXTENDER.....3-1-11	Maintenance—Every 1000 Hours
Testing Diesel Engine Coolant.....3-1-12	Replace Secondary Air Cleaner Element3-7-1
Maintenance—Periodic Maintenance	Change Chain Case Oil.....3-7-1
Service Machine at Specified Intervals.....3-2-1	Change Hydraulic Tank Oil.....3-7-2
Fuel Tank.....3-2-1	Maintenance—Every 2000 Hours
Raising and Blocking Machine3-2-1	Drain Cooling System.....3-8-1
Opening and Closing Rear Service Door3-2-1	Flush Cooling System.....3-8-1
Opening and Closing Engine Cover3-2-2	Fill Cooling System.....3-8-2
Removing Side Panels3-2-2	Miscellaneous—Machine
Raising Operator's Station3-2-3	Checking Radiator, Air Conditioning Condenser.....4-1-1
Removing Cover Plates.....3-2-4	Replacing Fan and Alternator Belt.....4-1-1
Maintenance and Repair Record Keeping System3-2-4	Adjusting Auxiliary Hydraulic Linkage—Hand-Foot Machines.....4-1-2
Fluid Analysis Program Test Kits and 3-Way Coolant Test Kit.....3-2-5	Adjusting Boom and Bucket Linkage—Hands Only Machine.....4-1-2
Service Intervals.....3-2-6	Adjusting Pedal Angle4-1-3
Required Parts.....3-2-7	Cleaning and Replacing Air Conditioner and Heater/Defroster Air Filters (If Equipped).....4-1-3
Maintenance—Every 10 Hours Or Daily	Checking Battery Electrolyte Level (Maintenance Type Batteries Only).....4-1-4
Check Engine Oil Level3-3-1	Using Battery Charger4-1-5
Check Hydraulic Tank Oil Level.....3-3-1	Cleaning or Replacing Battery.....4-1-6

Continued on next page

Contents

	Page
Using Booster Batteries—24-Volt System	4-1-7
Replacing Fuses	4-1-7
Replacing Blower Motor Fuse	4-1-8
Replacing Glow Plug Fuse	4-1-9
Unified Inch Bolt and Cap Screw Torque Values	4-1-10
Metric Bolt and Cap Screw Torque Values	4-1-11
Miscellaneous—Operational Checkout	
Operational Checkout	4-2-1
Miscellaneous—Troubleshooting	
Troubleshooting Procedure	4-3-1
Engine	4-3-1
Electrical System	4-3-2
Hydraulic System	4-3-3
Miscellaneous—Machine Storage	
Prepare Machine for Storage	4-4-1
Monthly Storage Procedure	4-4-1
Miscellaneous—Machine Numbers	
Record Product Identification Number (PIN)	4-5-1
Record Engine Serial Number	4-5-1
Keep Proof of Ownership	4-5-1
Keep Machines Secure	4-5-2
Miscellaneous—Specifications	
317 Engine Specifications	4-6-1
320 Engine Specifications	4-6-1
317 and 320 Drain and Refill Capacities	4-6-2
317 Machine Dimensions	4-6-3
320 Machine Dimensions	4-6-4
317 Tire Options and Pressures	4-6-5
320 Tire Options and Pressures	4-6-6
Pallet Fork Lift Chart	4-6-6

Contents

Safety—Safety and Operator Conveniences

Safety and Operator Convenience Features

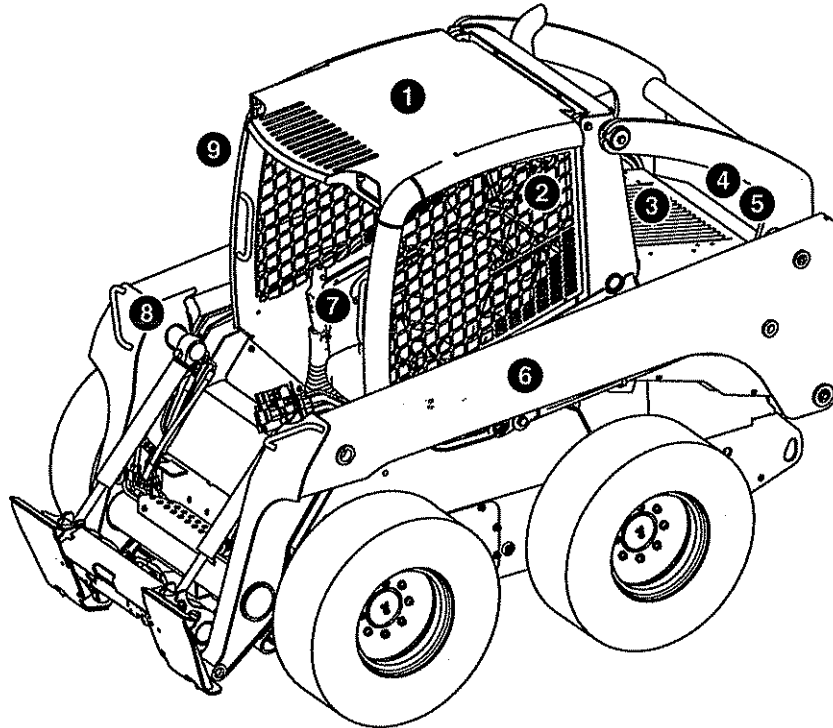

T196732

T196732—UN—05DEC03

Please remember that the operator is the key to preventing accidents.

- 1. ROPS/FOPS Protection.** Structures designed to help protect the operator are certified to ISO and OSHA. Enclosure also deflects sun and rain.
- 2. Window Guarding.** Side screens prevent contact with a moving boom.
- 3. Secondary Exit.** The rear window provides an exit path if the front door is blocked.
- 4. Bypass Start Protection.** Shielding over the starter terminals helps prevent dangerous bypass starting.
- 5. Engine Fan Guard.** A secondary fan guard inside engine compartment helps prevent contact with rotating fan blades.
- 6. Loader Boom Service Lock.** A mechanical lock is provided for working on or around this machine with the boom raised.

7. Seat Belt With Automatic Retractor. Retractor helps protect the operator and keeps the belt and operator's station clean. A convenient integrated seat and shoulder belt system is also available.

8. Handholds. Conveniently placed handholds make it easy to enter or exit the operator's station.

9. Independent Parking Brake. Is electrically controlled and engages whenever the engine is stopped.

10. (Not Shown) Cab with Integrated Shoulder Harness, Air Conditioner, Heater, Defroster. Options are available.

11. (Not Shown) Rearview Mirror. For operator convenience, a rearview mirror is available.

VD76477,0000092 -19-22MAR07-1/1

Safety—General Precautions

Recognize Safety Information

This is the safety alert symbol. When this symbol is noticed on the machine or in this manual, be alert for the potential of personal injury.

Follow the precautions and safe operating practices highlighted by this symbol.

A signal word — DANGER, WARNING, or CAUTION — is used with the safety alert symbol. DANGER identifies the most serious hazards.

On the machine, DANGER signs are red in color, WARNING signs are orange, and CAUTION signs are yellow. DANGER and WARNING signs are located near specific hazards. General precautions are on CAUTION labels.

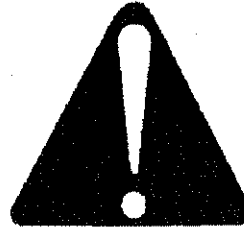

T133555—UN—28AUG00

T133558—19—28AUG00

TX03679,00016CC -19-03JAN07-1/1

Follow Safety Instructions

Read the safety messages in this manual and on the machine. Follow these warnings and instructions carefully. Review them frequently.

Be sure all operators of this machine understand every safety message. Replace operator's manual and safety labels immediately if missing or damaged.

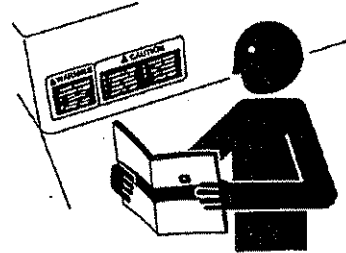

T133556—UN—24AUG00

TX03679,00016F9 -19-31JAN07-1/1

Operate Only If Qualified

Do not operate this machine unless the operator's manual has been read carefully, and you have been qualified by supervised training and instruction.

Operator should be familiar with the job site and surroundings before operating. Try all controls and

machine functions with the machine in an open area before starting to work.

Know and observe all safety rules that may apply to every work situation and work site.

TX03679,00016FA -19-03JAN07-1/1

Safety—General Precautions

Wear Protective Equipment

Guard against injury from flying pieces of metal or debris; wear goggles or safety glasses.

Wear close fitting clothing and safety equipment appropriate to the job.

Prolonged exposure to loud noise can cause impairment or loss of hearing. Wear suitable hearing protection such as earmuffs or earplugs to protect against objectionable or uncomfortable loud noises.

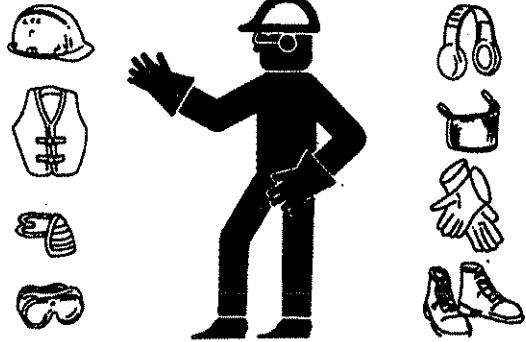

TS206—UN—23AUG88

TX03679,00016D0 -19-03JAN07-1/1

Avoid Unauthorized Machine Modifications

John Deere recommends using only genuine John Deere replacement parts to ensure machine performance. Never substitute genuine John Deere parts with alternate parts not intended for the application as these can create hazardous situations or hazardous performance. Non-John Deere Parts, or any damage or failures resulting from their use are not covered by any John Deere warranty.

Modifications of this machine, or addition of unapproved products or attachments, may affect machine stability or

reliability, and may create a hazard for the operator or others near the machine. The installer of any modification which may affect the electronic controls of this machine is responsible for establishing that the modification does not adversely affect the machine or its performance.

Always contact an authorized dealer before making machine modifications that change the intended use, weight or balance of the machine, or that alter machine controls, performance or reliability.

AM40430,00000A9 -19-29JUL08-1/1

Inspect Machine

Inspect machine carefully each day by walking around it before starting.

Keep all guards and shields in good condition and properly installed. Fix damage and replace worn or broken parts immediately. Pay special attention to hydraulic hoses and electrical wiring.



T6607AQ—UN—18OCT88

TX03679,0001734 -19-03JAN07-1/1

Stay Clear of Moving Parts

Entanglements in moving parts can cause serious injury.

Stop engine before examining, adjusting or maintaining any part of machine with moving parts.

Keep guards and shields in place. Replace any guard or shield that has been removed for access as soon as service or repair is complete.

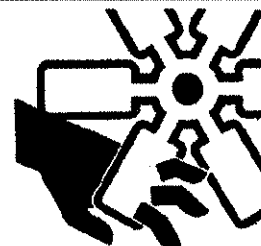

T133592—UN—12SEP01

TX03679,00016D2 -19-03JAN07-1/1

Safety—General Precautions

Avoid High-Pressure Fluids

Escaping fluid under pressure can penetrate the skin causing serious injury.

Avoid the hazard by relieving pressure before disconnecting hydraulic or other lines. Tighten all connections before applying pressure.

Search for leaks with a piece of cardboard. Protect hands and body from high pressure fluids.

If an accident occurs, see a doctor immediately. Any fluid injected into the skin must be surgically removed within a few hours or gangrene may result. Doctors unfamiliar with this type of injury should reference a knowledgeable medical source. Such information is available from Deere & Company Medical Department in Moline, Illinois, U.S.A.

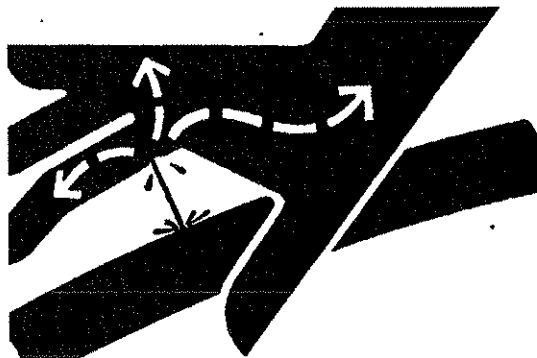

X9811—UN—23AUG88

DX_FLUID -19-03MAR93-1/1

Avoid High-Pressure Oils

This machine uses a high-pressure hydraulic system. Escaping oil under pressure can penetrate the skin causing serious injury.

Never search for leaks with your hands. Protect hands. Use a piece of cardboard to find location of escaping oil. Stop engine and relieve pressure before disconnecting lines or working on hydraulic system.

If hydraulic oil penetrates your skin, see a doctor immediately. Injected oil must be removed surgically within hours or gangrene may result. Contact a knowledgeable medical source or the Deere & Company Medical Department in Moline, Illinois, U.S.A.

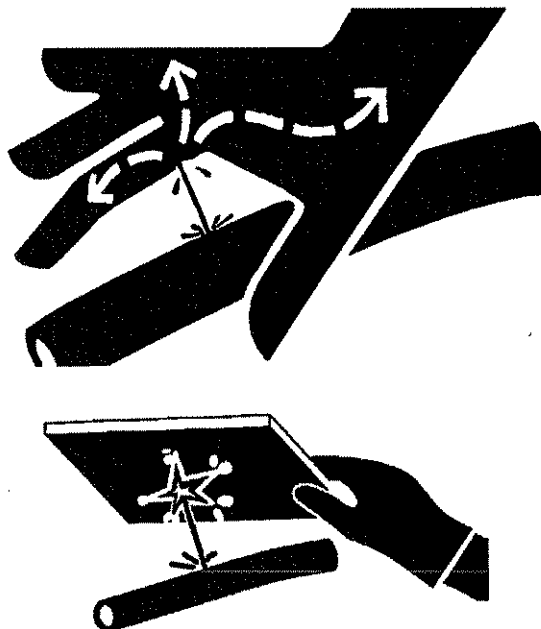

T133509—UN—17MAR06

T133840—UN—20SEP00

TX03679,00016D3 -19-03NOV08-1/1

Beware of Exhaust Fumes

Prevent asphyxiation. Engine exhaust fumes can cause sickness or death.

If you must operate in an enclosed space, provide adequate ventilation. Use an exhaust pipe extension to remove the exhaust fumes or open doors and windows to bring outside air into the area.

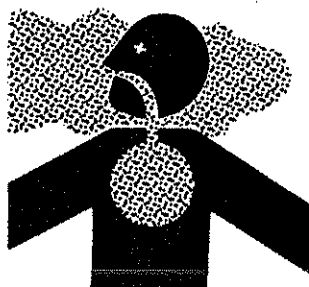

T133546—UN—24AUG00

JH91824,0000207 -19-14JUL08-1/1

Prevent Fires

Handle Fuel Safely: Store flammable fluids away from fire hazards. Never refuel machine while smoking or when near sparks or flame.

Clean Machine Regularly: Keep trash, debris, grease and oil from accumulating in engine compartment, around fuel lines, hydraulic lines, exhaust components, and electrical wiring. Never store oily rags or flammable materials inside a machine compartment.

Maintain Hoses and Wiring: Replace hydraulic hoses immediately if they begin to leak, and clean up any oil spills. Examine electrical wiring and connectors frequently for damage.

Keep A Fire Extinguisher Available: Always keep a multipurpose fire extinguisher on or near the machine. Know how to use extinguisher properly.



T133553 —UN—07SEP00



T133554 —UN—07SEP00

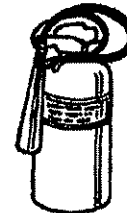

TX03679,00016F5 -19-03NOV08-1/1

T133552 —UN—14SEP00

Prevent Battery Explosions

Battery gas can explode. Keep sparks, lighted matches, and open flame away from the top of battery.

Never check battery charge by placing a metal object across the posts. Use a voltmeter or hydrometer.

Do not charge a frozen battery; it may explode. Warm battery to 16°C (60°F).



TX03679,000174A -19-03NOV08-1/1

TS204 —UN—23AUG88

Handle Chemical Products Safely

Exposure to hazardous chemicals can cause serious injury. Under certain conditions, lubricants, coolants, paints and adhesives used with this machine may be hazardous.

If uncertain about safe handling or use of these chemical products, contact your authorized dealer for a Material Safety Data Sheet (MSDS). The MSDS describes physical and health hazards, safe use procedures, and emergency response techniques for chemical substances. Follow MSDS recommendations to handle chemical products safely.



TX03679,00016D7 -19-31JAN07-1/1

T133580 —UN—25AUG00

Safety—General Precautions

Dispose of Waste Properly

Improper disposal of waste can threaten the environment. Fuel, oils, coolants, filters and batteries used with this machine may be harmful if not disposed of properly.

Never pour waste onto the ground, down a drain, or into any water source.

Air conditioning refrigerants can damage the atmosphere. Government regulations may require using a certified service center to recover and recycle used refrigerants.

If uncertain about the safe disposal of waste, contact your local environmental or recycling center or your authorized dealer for more information.

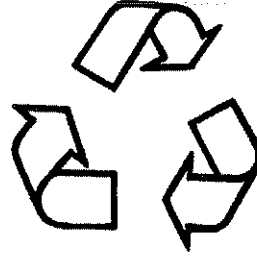

T193557—JUN—25AUG00

TX03679,0001733 -19-31JAN07-1/1

Prepare for Emergencies

Be prepared if an emergency occurs or a fire starts.

Keep a first aid kit and fire extinguisher handy.

Keep emergency numbers for doctors, ambulance service, hospital, and fire department near your telephone.

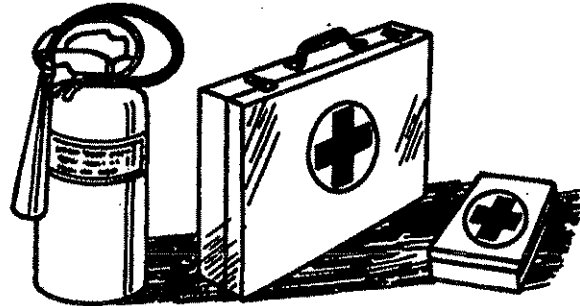

TS291—JUN—23AUG88

TX03679,000174B -19-03NOV08-1/1

Safety—Operating Precautions

Use Steps and Handholds Correctly

Prevent falls by facing the machine when getting on and off. Maintain 3-point contact with steps and handrails. Never use machine controls as handholds.

Use extra care when mud, snow, or moisture present slippery conditions. Keep steps clean and free of grease or oil. Never jump when exiting machine. Never mount or dismount a moving machine.

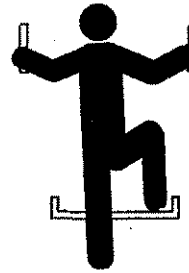

T133468 —UN—30AUG00

TX03679,00016F2 -19-15MAR07-1/1

Start Only From Operator's Seat

Avoid unexpected machine movement. Start engine only while sitting in operator's seat. Ensure all controls and working tools are in proper position for a parked machine.

Never attempt to start engine from the ground. Do not attempt to start engine by shorting across the starter solenoid terminals.

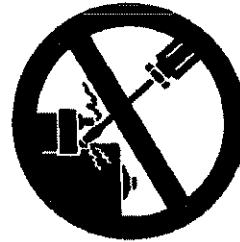

T133715 —UN—07SEP00

TX03679,0001799 -19-03JAN07-1/1

Use and Maintain Seat Belt

Use seat belt when operating machine. Remember to fasten seat belt when loading and unloading from trucks and during other uses.

Examine seat belt frequently. Be sure webbing is not cut or torn. Replace seat belt immediately if any part is damaged or does not function properly.

The complete seat belt assembly should be replaced every 3 years, regardless of appearance.



USE SEAT BELT

T133716 —19—14SEP00

TX03679,00016DD -19-03NOV08-1/1

Prevent Unintended Machine Movement

Be careful not to accidentally actuate controls when co-workers are present.

Lower all equipment to the ground during work interruptions. Press park brake to park position "P" to

engage park brake before allowing anyone to approach the machine.

Follow these same precautions before standing up, leaving the operator's seat, or exiting the machine.

TX14740,000006A -19-31JAN07-1/1

Avoid Work Site Hazards

Avoid contact with gas lines, buried cables, and water lines. Call utility line location services to identify all underground utilities before starting work.

Prepare work site properly. Avoid operating near structures or objects that could fall onto the machine. Clear away debris that could move unexpectedly if run over.

Avoid boom or attachment contact with overhead obstacles or overhead electrical lines. Never move machine closer than 3 m (10 ft) plus twice the line insulator length to overhead wires.

Keep bystanders clear at all times. Keep bystanders away from raised booms, attachments, and unsupported loads. Avoid swinging or raising booms, attachments, or loads over or near personnel. Use barricades or a signal person to keep vehicles and pedestrians away. Use a signal person if moving machine in congested areas or where visibility is restricted. Always keep signal person in view. Coordinate hand signals before starting machine.

Operate only on solid footing with strength sufficient to support machine. Be especially alert working near embankments or excavations.

Avoid working under over-hanging embankments or stockpiles that could collapse under or on machine.

Reduce machine speed when operating with tool on or near ground when obstacles may be hidden (e.g., during

snow removal or clearing mud, dirt, etc.). At high speeds hitting obstacles (rocks, uneven concrete, or manholes) can cause a sudden stop. Always wear your seat belt. On units equipped with shoulder belts always wear both the seat and shoulder belt and do not lean forward while operating.

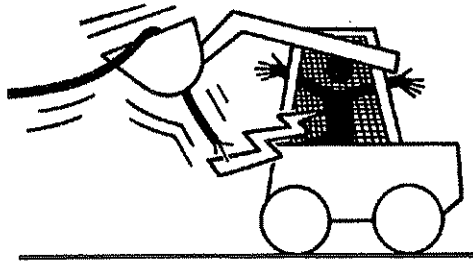

T192984—JUN—26AUG03

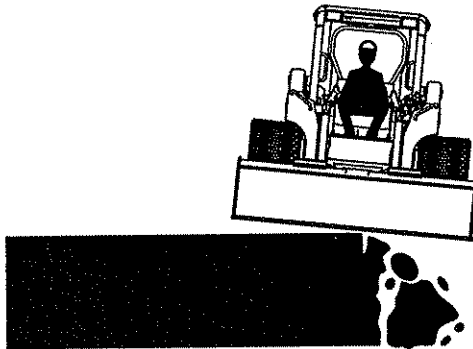

T211520—JUN—02JUN05

JH91824,000029E -19-04SEP08-1/1

Keep Riders Off Machine

Only allow operator on machine.

Riders are subject to injury. They may fall from machine, be caught between machine parts, or be struck by foreign objects.

Riders may obstruct operator's view or impair his ability to operate machine safely.

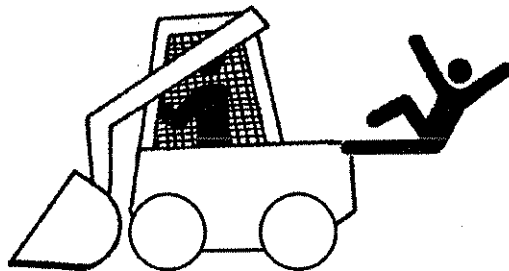

T192977—JUN—26AUG03

VD76477,0000094 -19-31JAN07-1/1

Avoid Backover Accidents

Before moving machine, be sure all persons or vehicles are clear of machine path. Turn around and look directly for best visibility. Keep windows clean.

Be certain reverse warning alarm is working properly (if equipped).

Use a signal person when backing if view is obstructed or when in close quarters. Keep signal person in view at all times. Use prearranged hand signals to communicate.

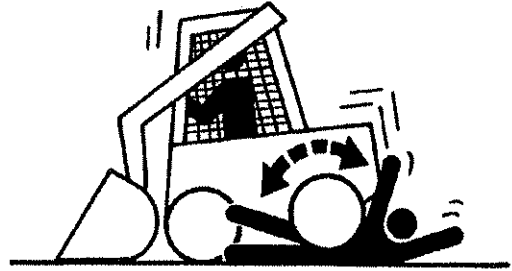

T192978—UN—26AUG03

VD76477,0000085 -19-31JAN07-1/1

Avoid Machine Tip Over

Use seat belt at all times.

Do not jump if the machine tips. You will be unlikely to jump clear and the machine may crush you.

Load and unload from trucks or trailers carefully. Be sure truck is wide enough and on a firm level surface. Use loading ramps and attach them properly to truck bed.

Be careful on slopes. Avoid sharp turns. Balance loads so weight is evenly distributed and load is stable. Carry tools and loads close to the ground to aid visibility and lower center of gravity. Use extra care on wet, soft, rocky, or frozen ground.

Know the capacity of the machine. Do not overload. Be careful with heavy loads. Using oversize buckets or lifting heavy objects reduces machine stability.

Ensure solid footing. Use extra care in soft ground conditions or on structures that may not uniformly support the wheels especially when raising the boom. Do not operate close to banks or open excavations that may cave in and cause machine to tip or fall.



**USE
SEAT
BELT**

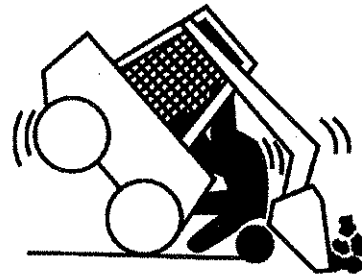

T133716—19—14SEP00

T192979—UN—26AUG03

VD76477,0000096 -19-20MAR07-1/1

Operating or Traveling On Public Roads

Machines that work near vehicle traffic or travel slower than normal highway speeds must have proper lighting and markings to assure they are visible to other drivers.

Install additional lights, beacons, slow moving vehicle (SMV) emblems, or other devices and use as required to make the machine visible and identify it as a work machine. Check state and local regulations to assure compliance. Keep these devices clean and in working condition.

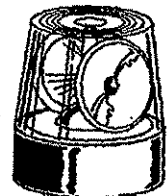
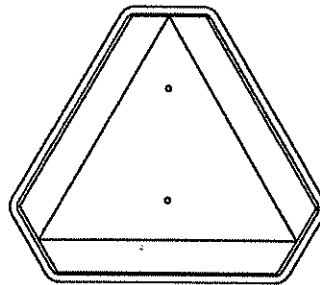

T141891—UN—22MAY01

DW90712,00001D0 -19-31JAN07-1/1

Add and Operate Attachments Safely

Always verify compatibility of attachments by contacting your authorized dealer. Adding unapproved attachments may affect machine stability or reliability, and may create a hazard for others near the machine.

Ensure that a qualified person is involved in attachment installation. Add guards to machine if operator protection

is required or recommended. Verify that all connections are secure and attachment responds properly to controls.

Carefully read attachment manual and follow all instructions and warnings. In an area free of bystanders and obstructions, carefully operate attachment to learn its characteristics and range of motion.

DW90712,00001CF -19-31JAN07-1/1

Safety—Maintenance Precautions

Park and Prepare for Service Safely

Warn others of service work. Always park and prepare machine for service or repair properly.

- Park machine on a level surface and lower equipment to the ground.
- Engage park brake.
- Stop engine and remove key.
- Attach a "Do Not Operate" tag in an obvious place in the operator's station.

Securely support machine or attachment before working under it.

- Do not support machine with any hydraulically actuated tools or attachments.
- Do not support machine with cinder blocks or wooden[®] pieces that may crumble or crush.
- Do not support machine with a single jack or other devices that may slip out of place.
- Always install boom lock before working on or around this machine with the loader boom raised.

Understand service procedures before beginning repairs. Keep service area clean and dry. Use two people whenever the engine must be running for service work.

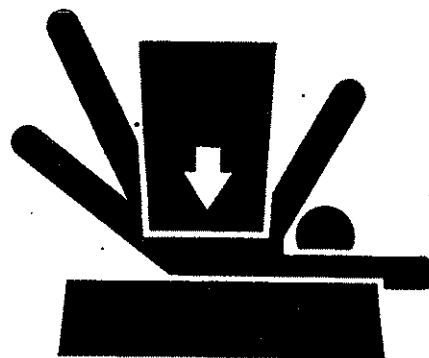
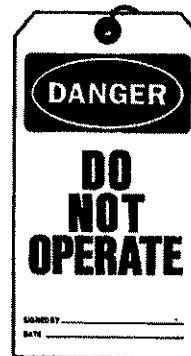

DW90712,00001D1 -19-09AUG06-1/1

T133332—19—14DEC01

TS229—JUN—23AUG88

Service Tires Safely

Explosive separation of a tire and rim parts can cause serious injury or death.

Do not attempt to mount a tire unless you have the proper equipment and experience to perform the job.

Always maintain the correct tire pressure. Do not inflate the tires above the recommended pressure. Never weld or heat a wheel and tire assembly. The heat can cause an increase in air pressure resulting in a tire explosion. Welding can structurally weaken or deform the wheel.

When inflating tires, use a clip-on chuck and extension hose long enough to allow you to stand to one side and NOT in front of or over the tire assembly. Use a safety cage if available.

Check wheels for low pressure, cuts, bubbles, damaged rims or missing lug bolts and nuts.

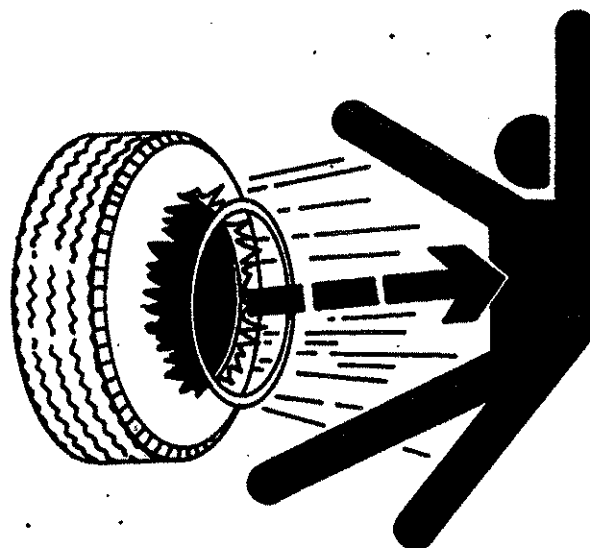

DX,RIM -19-24AUG90-1/1

TS211—JUN—23AUG88

Safety—Maintenance Precautions

Service Cooling System Safely

Explosive release of fluids from pressurized cooling system can cause serious burns.

Shut off engine. Only remove filler cap when cool enough to touch with bare hands. Slowly loosen cap to first stop to relieve pressure before removing completely.



TS281 —JUN—23AUG88

DX,RCAP -19-04JUN90-1/1

Remove Paint Before Welding or Heating

Hazardous fumes can be generated when paint is heated by welding or using a torch. Dust from sanding or grinding paint can also be hazardous.

Remove paint to at least 76 mm (3 in.) from area to be heated. Wear an approved respirator when sanding or grinding paint. If a solvent or paint stripper is used, wash area with soap and water. Remove solvent or paint stripper containers from work area and allow fumes to disperse at least 15 minutes before welding or heating.

Work outside or in a well-ventilated area. Dispose of waste, paint and solvents properly.

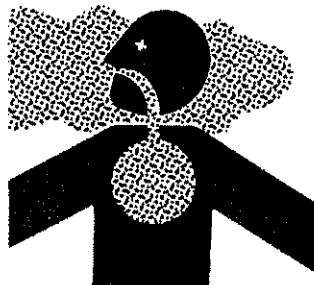

T133546 —JUN—24AUG00

TX17994,0000228 -19-11MAR02-1/1

Make Welding Repairs Safely

IMPORTANT: Disable electrical power before welding. Turn off main battery switch or disconnect positive battery cable. Separate harness connectors to engine and vehicle microprocessors.

Avoid welding or heating near pressurized fluid lines. Flammable spray may result and cause severe burns if pressurized lines fail as a result of heating. Do not let heat go beyond work area to nearby pressurized lines.

Remove paint properly. Do not inhale paint dust or fumes. Use a qualified welding technician for structural repairs.



T133547 —JUN—31AUG00

Make sure there is good ventilation. Wear eye protection and protective equipment when welding.

TX03679,00016D5 -19-31AUG07-1/1

Drive Metal Pins Safely

Always wear protective goggles or safety glasses and other protective equipment before striking hardened parts. Hammering hardened metal parts such as pins and bucket teeth may dislodge chips at high velocity.

Use a soft hammer or a brass bar between hammer and object to prevent chipping.

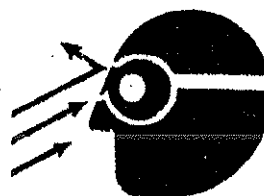

T133738 —JUN—14SEP00

TX03679,0001745 -19-25SEP00-1/1

Safety—Safety Signs

Safety Signs

CAUTION
Avoid an Explosion

- See operator manual
- Do not use starting fluid
- Air electric heater may ignite starting fluid.

42-1344

WARNING

KV25323

IMPORTANT

Engage Park Brake to Start Engine

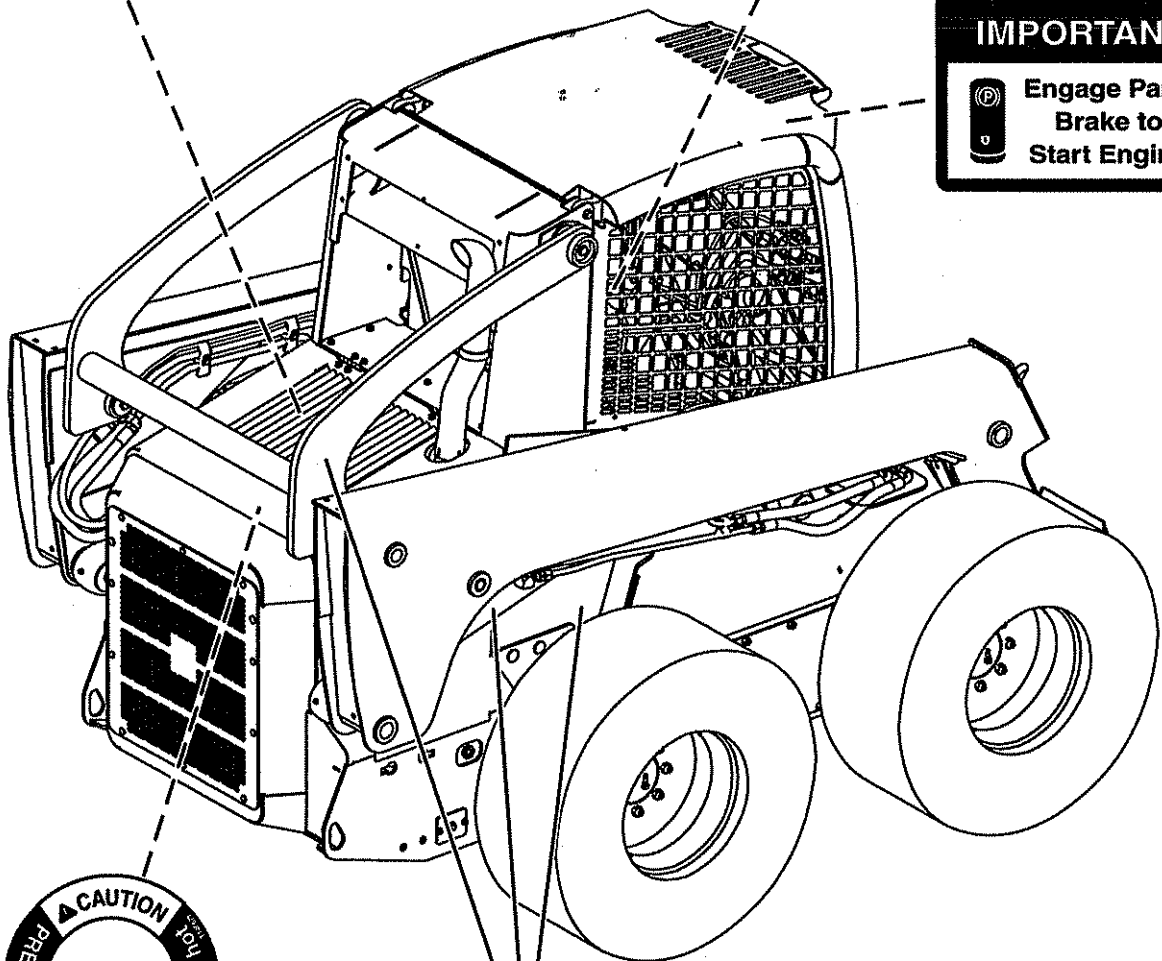

CAUTION
PRESSURIZED - DO NOT open when you are

WARNING
Pinch Area
Keep Away

T198266

Right Side Shown

Continued on next page

VD76477,0000098 -19-31JAN07-1/2

T198266 -19-03MAR04

Safety—Safety Signs

WARNING



Always install boom lock before working on or around this machine with the loader boom raised.

See Operator's Manual for complete instructions.

CAUTION

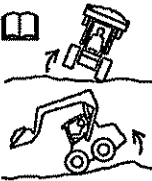

Avoid Overturn

- Carry load low.
- Avoid steep slopes and high speed turns.
- Rated operating capacity: 1990 lbs. (903 kg)

WARNING

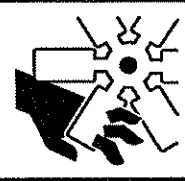

Avoid rotating fan.
Stop engine.
Keep clear to avoid serious injury.

WARNING



Avoid crushing injury.

Boom linkage moves near engine hood and frame.

Never stand or lean anywhere on loader.

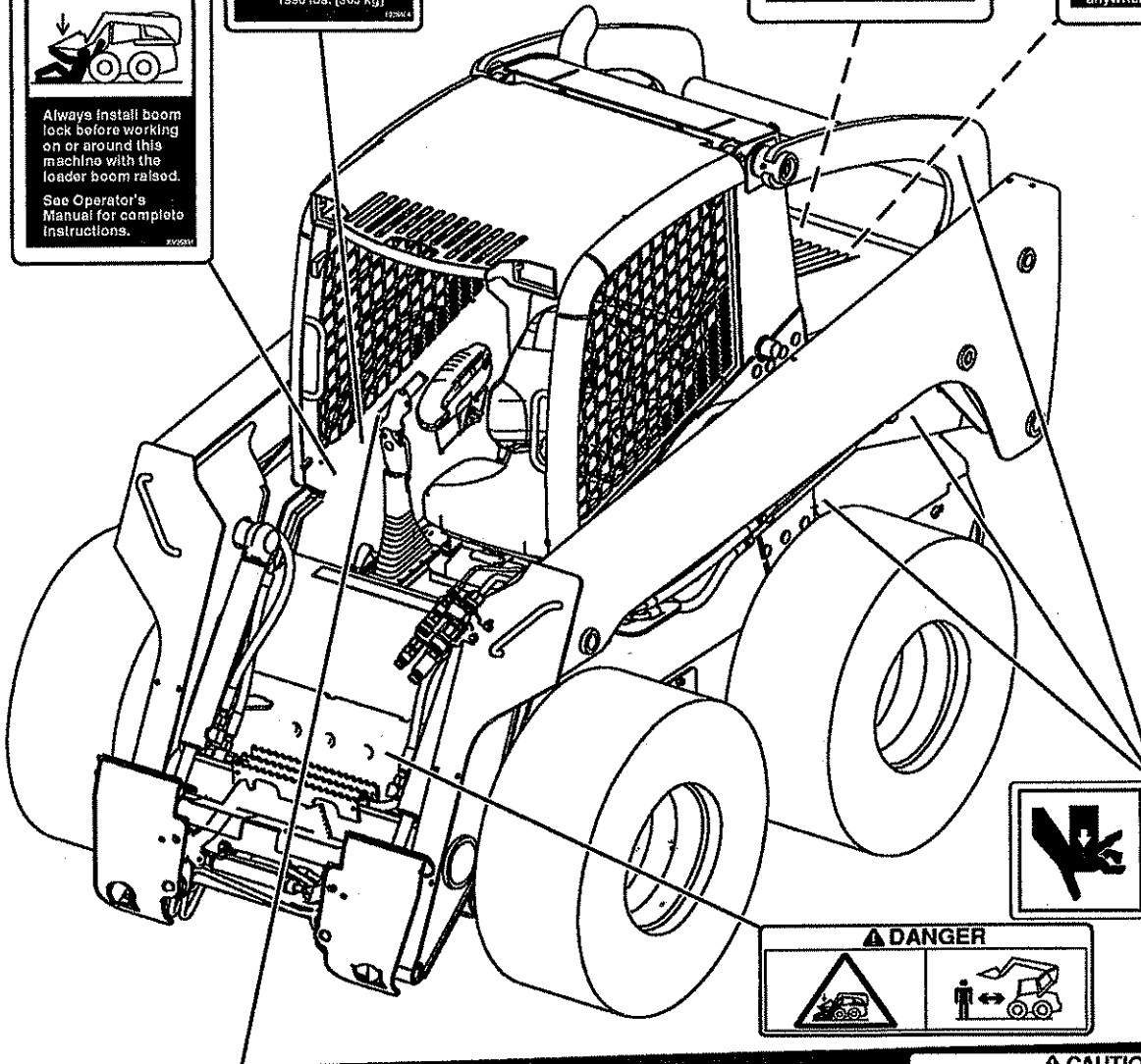

WARNING



Pinch Area
Keep Away

DANGER



DANGER



CAUTION



CAUTION

- AVOID INJURY: Read and understand Operator's Manual before operating this machine.
- Know location and function of controls.
- Keep safety devices working.
- Keep children and windows in place.
- Keep children and others away.
- Never carry riders.
- Lower boom, engage park brake, stop engine and remove key before leaving.
- Keep cautions, especially pedal area.

T198268

Left Side Shown

VD76477,0000098 -19-31JAN07-2/2

T198268—1B—19MAR04

Operation—Operator's Station

Pedals and Levers - Standard Controls

- | | |
|---|---|
| 1—Steering Levers | 6—Right Pedal—Bucket Control (hand-foot machine) |
| 2—Horn Button (if equipped) | — Right Pedal—Aux. Hydraulic Control (hands only machine) |
| 3—Engine Speed Control Lever | 7—Left Handle—Boom Control (hands only machine) |
| 4—Boom Lock Lever | 8—Right Handle—Aux. Hydraulic Control (hand-foot machine) |
| 5—Left Pedal—Boom Control (hand-foot machine) | — Right Handle—Bucket Control (hands-only machine) |

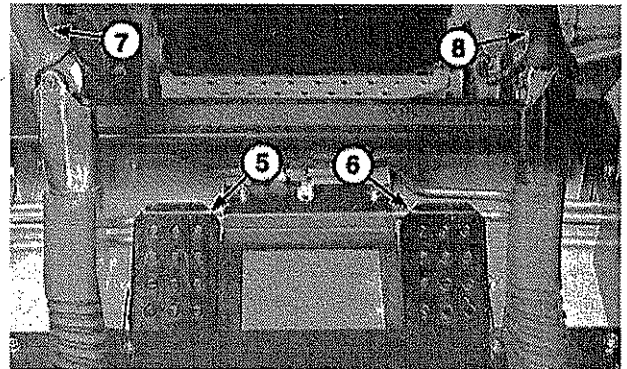
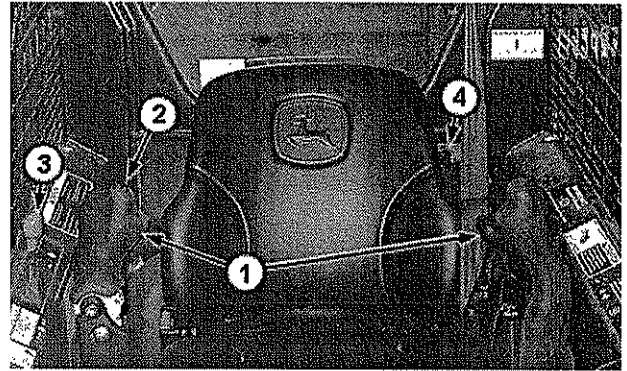

T199116A—UN—12APR04

TX1035264A—UN—23JAN08

TX14740,0000131 -19-22JAN08-1/1

Instrument Panel—EH Controls Machine

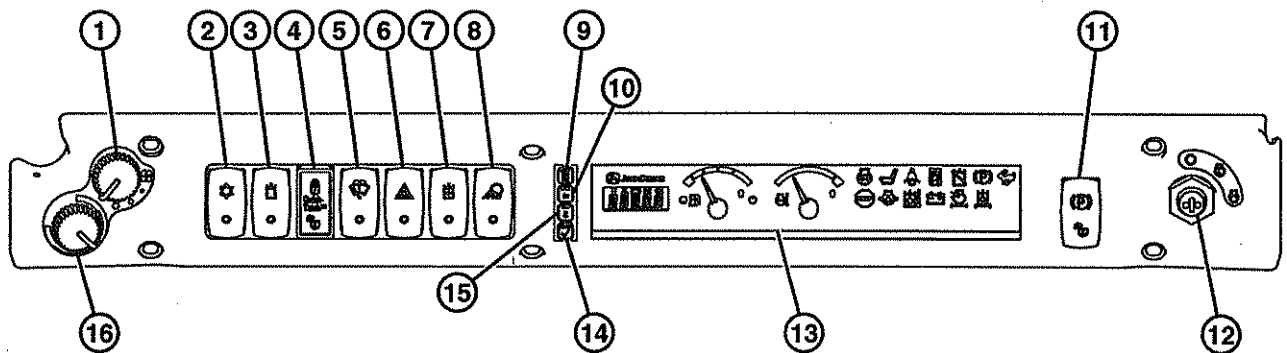

TX1030413

- | | | | |
|--|----------------------------------|----------------------|---------------------------------|
| 1—Air Conditioner and Heater Blower Motor Switch | 5—Windshield Wiper/Washer Switch | 9—MENU Button | 13—Engagement and Monitor Unit |
| 2—Air Conditioner Switch | 6—Dual Flasher Switch | 10—BACK Button | 14—SELECT Button |
| 3—Auxiliary Hydraulic Override Switch | 7—High Flow Switch | 11—Park Brake Switch | 15—NEXT Button |
| 4—Quik-Tatch Switch | 8—Work Lights Switch | 12—Key Switch | 16—Cab Temperature Control Dial |

TX1030413—UN—16OCT07

TX14740,0000107 -19-05NOV07-1/1

Instrument Panel Functions—EH Controls Machine

1—Air Conditioner and Heater Blower Motor Switch:

Turn switch clockwise to increase blower speed. Turn counterclockwise to decrease blower speed.

2—Air Conditioner Switch: Push upper half of switch to turn on air conditioner. Push lower half of switch to turn off air conditioner.

3—Auxiliary Hydraulic Override Switch: Allows auxiliary hydraulics to operate after operator exits machine. This switch has two positions:

- Push upper half of switch to momentary position to activate bypass mode. Switch will return to lower position when released.

4—Quik-Tatch Switch: Press and hold upper half of switch to engage lock pins. Press and hold lower half of switch to retract lock pins.

NOTE: The switch will automatically return to center position when released. The mounting plates will stop at the position they are in at the time the switch is released.

5—Windshield Wiper/Washer Switch: This switch has three positions:

- Push upper half of switch to momentary position to release windshield washer fluid. Switch will return to "On" position when released.
- Push to middle position to turn wiper on.
- Push lower half of switch to turn wiper off.

6—Dual Flasher Switch: Push upper half of switch to turn warning lights on. Push lower half of switch to turn warning lights off.

7—High Flow Switch: Used for attachments that require a high hydraulic flow rate to operate. This switch has three positions:

- Push upper half of switch to momentary "On" position, and release to activate high flow option. Switch will return to center "Run" position.
- Middle position is the "Run" position.
- Push lower half of switch to deactivate high flow option.

8—Work Lights Switch: This switch has three positions:

- Push upper half of switch to turn on front work lights, red tail lights, and rear work light.
- Push to middle position to turn on front work lights and red tail lights.
- Push lower half of switch to turn lights off.

9—MENU Button: Press button to scroll through menu on the engagement and monitor unit.

10—BACK Button: Press button to scroll backwards through screen selections on the engagement and monitor unit.

11—Park Brake Switch: This switch has three positions:

- Push upper half of switch to engage park brake. This position also hydraulically locks the boom and bucket.
- Push to middle position to hydraulically enable boom and bucket while park brake is engaged.

NOTE: Operator must be in seat with seat belt fastened, and engine must be running to disengage park brake.

- Push lower half of switch to momentary position, and release to middle position to disengage park brake.

12—Key Switch: This switch has three positions:

- Position where ignition key can be inserted or removed is the "off" position. No circuits are active in this position.
- Turn key **clockwise** from the "off" position. This is the "run" position for the engine.
- Turn key **clockwise** from the "run" position. This is the "start" position for the engine. After starting engine, release key. Key will return to "run" position.

13—Engagement and Monitor Unit: Displays status of machine systems.

14—SELECT Button: Press button to select a menu or an item under a menu.

14—NEXT Button: Press button to scroll forward through screen selections on the engagement and monitor unit.

16—Cab Temperature Control Dial: Turn dial clockwise to increase cab temperature. Turn dial counterclockwise to decrease cab temperature.

TX14740,00000E1 -19-10APR07-1/1

Engagement and Monitor Unit Operation

The engagement and monitor unit can be used to display vital operating information, hours, diagnostic trouble codes, diagnostics, and to configure units of measure. It can also be used to lock the machine using an anti-theft security system. When the engagement and monitor unit powers up, the display initially shows the machine model setting for 3 seconds, and then will show the hour meter for 10 seconds before it defaults to Run Data Items. If the anti-theft system is enabled on the machine, the lock status appears after the machine model setting has been shown. See Anti-Theft Security System in this section for more information. The "MENU" button is used to scroll through the menus or to return to the Run Data Items when in a sub-menu. The "SELECT" button is used to scroll through the Run Data Items or to select a menu item.

Run Data Items

The Run Data Items are the default display when the engagement and monitor unit is powered up. The Run Data Items may also be displayed by cycling through the menu items by pressing the "MENU" button, or by pressing "MENU" at any time while in a sub-menu. Pressing "SELECT" while viewing a Run Data Item will scroll through all the Run Data Items.

- Hours
- Engine rpm
- Volts
- Hydraulic Temperature
- Engine Temperature

If "CHECK CODES" appears in the engagement and monitor unit display, press "SELECT" to return to the Run Data Items. "CHECK CODES" will appear for any hydraulic, park brake, or auto shutdown diagnostic trouble codes. Once "CHECK CODES" appears in the display, it will become part of the list of Run Data Items. Once the diagnostic trouble code is cleared, the "CHECK CODES" will no longer be part of the Run Data Item list. If possible, move machine to a safe location before checking the diagnostic trouble codes. See Reading Engagement and Monitor Unit Diagnostic Trouble Code in this section.

Job Menu

The Job Menu is a hour meter that can be reset. To reset the Job hour meter, press and hold the "Select" button for 5 seconds.

Code Menu

The Code Menu displays any diagnostic trouble codes that may be present in the machine. The Code Menu displays both machine and engine diagnostic trouble codes. For more information, see Reading Engagement and Monitor Unit Diagnostic Trouble Codes.

Diagnostic Menu

The Diag Menu displays diagnostic information from various switches on the machine.

Configuration Menu

The Config Menu is used to change how the information in the engagement and monitor unit is displayed. Press "Select" to scroll through the available features to configure. To change the configuration of a feature, press and hold the "Select" button for 5 seconds.

Machine Model Setting

The engagement and monitor unit uses a machine model setting to set fuel gauge calibration and two speed shift modulation for specific machine models. The machine model number displays for 3 seconds when the engagement and monitor powers on.

Anti-Theft Security System

The optionally-enabled anti-theft security system within the engagement and monitor unit provides a basic level of machine theft protection. When the anti-theft security system is enabled, the machine can be unlocked and locked with the use of either a 3-digit or 5-digit security code (depending on how the system is configured.) This security code, along with the machine key switch, is necessary to start and run the engine. When locked, the anti-theft security system prevents the engine from starting by disabling the fuel shutoff solenoid (Y1).

There are three levels of security within the anti-theft security system: Operator, Owner, and Master. The Operator level of security provides three different security codes that can be used by machine operators. The Owner level of security is designed for the owner or equipment manager. This security level is primarily to be used as a safeguard in the event an Operator code is forgotten or unknown, and the owner wishes to change or replace that security code.

After entering a valid Owner security code, the owner can:

- Lock and unlock the machine.
- Change the Owner security code.
- Change/reset an Operator security code.
- Enable/disable the auto lock feature.

The Master level of security is the highest security level and is used to enable or disable the anti-theft security system. A Master security code can be obtained for a machine by an owner by contacting their John Deere Dealer. The dealer will need the current engine hour meter reading and the machine's serial number to generate a new Master security code.

All security codes are three digit numbers that are entered using the "MENU" and "SELECT" buttons on the engagement and monitor unit. Unlock or lock prompts appear on the engagement and monitor unit display at machine power up or power down, respectively. If the anti-theft security system is not enabled on the machine, no prompts will appear.

Auto Lock Feature

Continued on next page

KH31969,0000001 -19-21DEC07-1/2

Operation—Operator's Station

The auto lock feature, when enabled, automatically locks the machine 1 hour after the operator leaves the seat if

the machine had been left unlocked when turning key switch to OFF position.

KH31969,0000001 -19-21DEC07-2/2

Anti-Theft Security System Operation

IMPORTANT: When providing Operator security codes to machine users, owners should not provide operators with the default codes. Instead, owners should first change the default Operator security codes to other values before providing codes to machine users. See Changing a Security Code in this section.

NOTE: On a locked machine, engine can be started but will shut down after 3 seconds.

Unlocking the Machine (Operator)

1. Sit in the operator's seat to power up the engagement and monitor unit.
2. Turn key switch to ON position.
3. "LOCKA" appears on the engagement and monitor unit display.
4. Press "SELECT" to unlock machine using an Operator security code (LOCKA).
5. At the "0 - -" prompt, enter the appropriate security code:
 - a. Press "MENU" to change the number displayed in the active (blinking) field.
 - b. Press "SELECT" to accept the number displayed in the active field, and shift the active field to the next digit to the right.

NOTE: Pressing "SELECT" to accept the last digit (third digit or fifth digit depending on system configuration) will process the entered security code. If the code is incorrect, an error message appears on the engagement and monitor unit display.

The anti-theft security system allows three attempts to enter a valid security code before requiring the key switch to be turned OFF and ON to restart the process.

6. If a correct security code was entered, "UNLKD" appears for 3 seconds on the engagement and monitor unit display before returning to Run Data Items.

Unlocking the Machine (Owner)

1. Sit in the operator's seat to power up the engagement and monitor unit.
2. Turn key switch to ON position.
3. "LOCKA" appears on the engagement and monitor unit display.
4. Press "MENU" and then "SELECT" to unlock the machine using the Owner security code ("LOCKB").
5. At the "0 - -" prompt, enter the appropriate security code:

- a. Press "MENU" to change the number displayed in the active (blinking) field.
- b. Press "SELECT" to accept the number displayed in the active field, and shift the active field to the next digit to the right.

NOTE: Pressing "SELECT" to accept the last digit (third digit or fifth digit depending on system configuration) will process the entered security code. If the code is incorrect, an error message appears on the engagement and monitor unit display.

The anti-theft security system allows three attempts to enter a valid security code before requiring the key switch to be turned OFF and ON to restart the process.

6. If a correct security code was entered, "UNLKD" appears for 3 seconds on the engagement and monitor unit display before returning to Run Data Items.

Locking the Machine

1. Turn key switch to the OFF position.
2. Press "SELECT" at the "LOCK?" prompt.
3. The anti-theft system locks the machine, and "LOCKD" appears for 3 seconds on the engagement and monitor unit before returning to the Run Data Items.
4. Exit the operator's seat to power down the engagement and monitor unit.

NOTE: On a locked machine, engine can be started but will shut down after 3 seconds.

Enable or Disable the Auto Lock Feature

When using the auto lock feature, a machine left unlocked when the key switch is turned to OFF position will switch to locked 1 hour after the operator has left the seat.

Complete the following procedure to enable or disable the auto lock feature. The machine must have been unlocked using the Owner security code in order to enable or disable this feature.

NOTE: The machine must be locked first (if not already locked) before it can be unlocked with the Owner security code.

1. Unlock the machine using the Owner security code.
2. Press "MENU" until "CONFG" appears on the engagement and monitor unit display.
3. Press "SELECT" to enter the "CONFG" menu.
4. Press "MENU" until "AUTOL" appears on the display.

5. Press and hold "SELECT" for 5 seconds to enable or disable the auto lock feature, depending on the previous setting.
6. Press "MENU" when finished to return to the Run Data Items.

Changing an Operator or Owner Security Code

The following rules apply when changing security codes:

- An Operator security code (LCKA1, LCKA2, LCKA3) can only be changed if that security code was used to unlock the anti-theft security system.
- An Operator security code can only be reset to the default value if the Owner security code was used to unlock the anti-theft security system.
- Duplicate Operator security codes are not allowed.
- The Owner security code (LOCKB) can only be changed if that code was used to unlock the anti-theft security system.
- The anti-theft security system resets all Operator security codes and the Owner security code to their default values when the Master security code is used to enable the system.

NOTE: The machine must be locked first (if not already locked) before it can be unlocked.

1. Unlock the machine using one of the Operator security codes or the Owner Security code.

NOTE: If this is a new machine or the codes have never been changed, the default operator codes will be 000, 999, or 998 for 3-digit security systems, and 00000, 00999, and 00998 for 5-digit security systems. The default owner code will be 111 for 3-digit security systems and 00111 for 5-digit security systems.

2. Turn key switch to OFF position.
3. At the "LOCK?" prompt, press "MENU" until "LOCKA" (for changing Operator security codes) or "LOCKB" (for changing Owner security code) appears.
4. Press "SELECT."
5. At the "--" prompt, enter the new security code:
 - a. Press "MENU" to change the number displayed in the active (blinking) field.
 - b. Press "SELECT" to accept the number displayed in the active field and shift the active field to the next digit to the right.

NOTE: Pressing "SELECT" to accept the last digit (third digit or fifth digit depending on system configuration) will process the new security code. The previous security code will no longer be valid.

NOTE: If a dash ("-") is selected for all three digits, the security code will not be changed.

6. The anti-theft security system locks the machine using the new security code.

Resetting Operator Security Codes

NOTE: The machine must be locked first (if not already locked) before it can be unlocked with the Owner security code.

1. Unlock the machine using the Owner security code.
2. Turn the key switch to the "OFF" position to display the "LOCK?" prompt.
3. Press "MENU" until the appropriate Operator security code appears: "LCKA1", "LCKA2", "LCKA3".
4. Press "SELECT."
5. Press "SELECT" at the "RST?" prompt to reset the Operator security code back to the default.

The default Operator security code ("000", "999", or "998" for 3-digit security codes; "00000", "00999", or "00998" for 5-digit security codes) appears for 3 seconds before the engagement and monitor unit returns to Run Data Items.

6. Repeat steps 3—5 to reset additional Operator security codes.

Changing Security Code Length

The length of security code (3-digit or 5-digit) to use with the anti-theft security system can only be changed if the security system is currently enabled on the machine.

NOTE: The machine must be locked first (if not already locked) before it can be unlocked with the Owner security code.

1. Unlock the machine using the Owner security code.
2. Press "MENU" until "CONFG" appears on the engagement and monitor unit display.
3. Press "SELECT" to enter the "CONFG" menu.
4. Press "MENU" until "ATS 3" or "ATS 5" appears on the display, depending on the current machine setting. The default setting is "ATS 3" (3-digit security codes.)
5. Press and hold "SELECT" for 5 seconds to change the security code length.
6. Press "MENU" when finished to return to the Run Data Items.

Engagement and Monitor Unit Data Items

Run Data Items

The Run Data Items are the default display when the engagement and monitor unit is powered up. The Run Data Items may also be displayed by cycling through the menu items by pressing the "MENU" button, or by pressing "MENU" at any time while in a sub-menu. Pressing "Select" while viewing a Run Data Item will scroll through all the Run Data Items.

- Hours
- Engine rpm
- Volts
- Hydraulic Temperature
- Engine Temperature

Air Conditioner Compressor Shutdown

"ACoFF" will appear in the engagement and monitor unit display. When engine coolant temperature or hydraulic oil temperature are 103°C (217°F) or greater, the engagement and monitor unit will disable the air conditioner compressor clutch relay (K7). This stops the air conditioner compressor from operating. This will reduce the load on the engine and allow for cooler air

to be drawn through the engine coolant radiator and hydraulic oil cooler. When the engine coolant temperature or hydraulic oil temperature drop below 100.6°C (213°F), the engagement and monitor unit will enable the air conditioner compressor clutch relay allowing the air conditioner compressor to operate.

Diagnostic Display Items

The Diagnostic Display Items are available under the "DIAG" menu in the engagement and monitor unit.

1. Press "MENU" until "DIAG" appears on the engagement and monitor unit display.
2. When "DIAG" appears, press "SELECT" to enter the sub-menu.
3. The Diagnostic Display Items are shown in three parts, a two part signal name and then the value of the signal. Pressing "SELECT" again will scroll through the Diagnostic Display Items.
4. Pressing "MENU" while viewing a Diagnostic Display Item will return the display to the last Run Display item.

Signal	Signal Identification 1	Signal Identification 2	Value	Description
1	PARK	RUN	ON/OFF	When park brake switch is in the "RUN" position, signal value will be "ON"
2	PARK	REL	ON/OFF	When park brake switch is held in "RELEASE" position, signal value will be "ON"
3	SEAT	SW	ON/OFF	When operator is in seat, signal value will be "ON"
4	SEAT	BELT	ON/OFF	When seat belt is fastened, signal value will be "ON"
5	DOOR	LATCH	ON/OFF	When cab door is fully closed, signal value will be "ON"
6	2-SPD	SW	ON/OFF	When two speed switch is pressed and held, signal value will be "ON"
7	OVER	RIDE	ON/OFF	When auxiliary hydraulic override switch is held in "ON" position, signal value will be "ON"
8	VALVE	SPOOL	ON/OFF	When auxiliary hydraulics are activated, signal value will be "OFF"

ER93822,000005E -19-08JAN09-1/1

Reading Engagement and Monitor Unit Diagnostic Trouble Codes

The diagnostic trouble codes can only be viewed from the engagement and monitor unit. The engagement and monitor unit displays both engine and machine diagnostic trouble codes. To access the diagnostic trouble codes:

1. Press "MENU" on the engagement and monitor unit until "CODES" appears in the engagement and monitor unit display.
2. Press "SELECT" to enter the "CODES" menu.
3. Pressing "SELECT" again will scroll through the diagnostic trouble codes if any are present in the machine.
4. If no diagnostic trouble codes are present, or when the end of the diagnostic trouble code list is reached, "END" will appear in the engagement and monitor unit display.
5. Press "SELECT" again, and "WAIT" will display on the engagement and monitor unit.
6. When "WAIT" is displayed, press "SELECT" to scroll back through the diagnostic trouble code list, or hold "SELECT" for 5 seconds to clear the stored diagnostic trouble codes. After the diagnostic trouble codes are cleared, "END" will appear on the engagement and monitor unit display.

LD30992,0000096 -19-08JAN09-1/1

Gauges and Indicator Lights — Hands-Only and Hand-Foot Machines

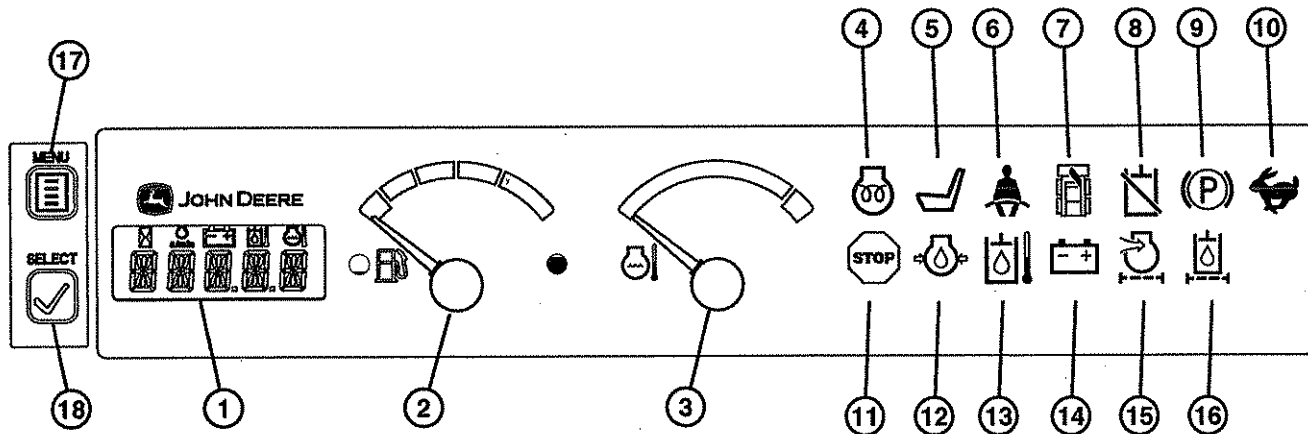

T197653

- | | | | |
|---------------------------------------|------------------------------|--|---|
| 1—Engagement and Monitor Unit Display | 6—Seat Belt Switch Indicator | 11—STOP Indicator | 16—Hydraulic Oil Filter Restriction Indicator |
| 2—Fuel Gauge | 7—Cab Door Switch Indicator | 12—Engine Low Oil Pressure Indicator | 17—MENU Button |
| 3—Engine Coolant Temperature Gauge | 8—Hydraulics OFF Indicator | 13—Hydraulic Oil Temperature Indicator | 18—SELECT Button |
| 4—Glow Plug Indicator | 9—Park Brake Indicator | 14—Low Alternator or Battery Voltage Indicator | |
| 5—Seat Switch Indicator | 10—High Speed Indicator | 15—Engine Air Filter Restriction Indicator | |

TX14740,0000108 -19-08JAN08-1/1

T197653—JUN—28MAR04

Gauge and Indicator Light Functions — Hands-Only and Hand-Foot Machines

1—Engagement and Monitor Unit Display:

2—**Fuel Gauge:** Indicates amount of fuel in fuel tank.

3—**Engine Coolant Temperature Gauge:** Indicates temperature of engine coolant.

4—**Glow Plug Indicator:** Indicator will light when glow plugs are activated.

5—**Seat Switch Indicator:** Indicator will light when operator is not in the seat and seat belt is not fastened.

6—**Seat Belt Switch Indicator:** Indicator will light when operator is not in the seat and seat belt is not fastened.

7—**Cab Door Switch Indicator:** Indicator will light when cab door is open.

8—**Hydraulics OFF Indicator:** Indicator will light when hydraulics are disabled.

9—**Park Brake Indicator:** Indicator will light when park brake is engaged.

10—**High Speed Indicator:** Indicator will light when machine is in Fast Speed mode.

11—**STOP Indicator:** Indicator will light when machine should be shut down.

12—**Engine Low Oil Pressure Indicator:** Indicator will light when engine oil pressure is too low.

13—**Hydraulic Oil Temperature Indicator:** Indicator will light when hydraulic oil temperature is too high.

14—**Low Alternator or Battery Voltage Indicator:** Indicator will light when alternator output is low or battery voltage is low.

15—**Engine Air Filter Restriction Indicator:** Indicator will light when air filter elements are restricted.

16—**Hydraulic Oil Filter Restriction Indicator:** Indicator will light when hydraulic filter element is restricted.

17—**MENU Button:** Press button to scroll through menu on the engagement and monitor unit.

18—**SELECT Button:** Press button to select a menu or an item under a menu.

TX14740,0000109 -19-08JAN08-1/1

Auto Shutdown With Alarm

- Engine coolant temperature gauge will indicate full hot, the alarm will sound, STOP indicator will flash, and the Engagement and Monitor Unit will shut the engine down after 5 seconds when engine coolant temperature is too high. The engine can be restarted and will run for 30 seconds before it will shut down again.
- Oil pressure indicator will light, the alarm will sound, STOP indicator will flash, and the Engagement and Monitor Unit will shut the engine down after 5 seconds when engine oil pressure is too low. The engine can be restarted and will run for 30 seconds before it will shut down again.
- Hydraulic oil temperature indicator will light, the alarm will sound, STOP indicator will flash, and the Engagement and Monitor Unit will shut the engine down after 5 minutes when hydraulic oil temperature is too high. The engine can be restarted and will run for 30 seconds before it will shut down again.

TX14740,000010E -19-06FEB08-1/1

Horn Button—If Equipped

Push button (1) to sound horn.

1—Horn Button



T198122A—JUN—12APR04

Standard Controls Machine

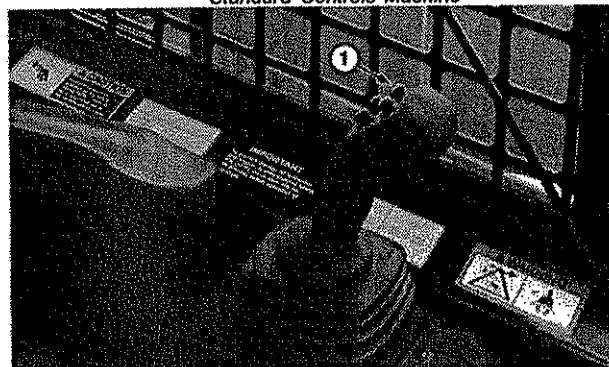

TX1031685A—JUN—08JAN08

EH Controls Machine

TX14740,0000125 -19-29JAN08-1/1

12-Volt Power Outlet

NOTE: Machine must be powered for operation.

Keep outlet free of dirt and moisture for uninterrupted operation.

1—Power Outlet

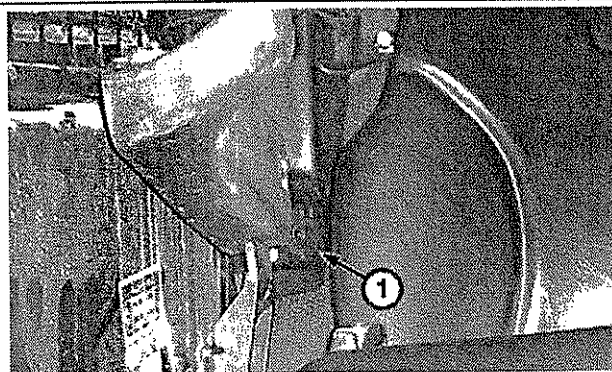

T214028A—JUN—30AUG05

VD76477,0000153 -19-23JAN08-1/1

Dome Light

NOTE: Machine must be powered for operation.

To operate dome light (1), push on lens, right or left of center detent position.

1— Dome Light

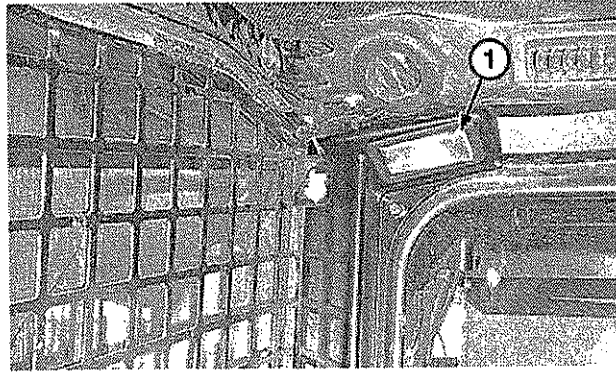

TX1003064A —JUN—25JAN06

DW90712,0000057 -19-23JAN08-1/1

Heating/Defrosting Controls—If Equipped

Turn heater/defroster blower switch (1) clockwise to turn heater/defroster on and to increase blower speed. The switch has four positions and "off."

Turn temperature control knob (2) clockwise to increase temperature.

1— Heater/Defroster Blower Switch 2— Temperature Control Knob

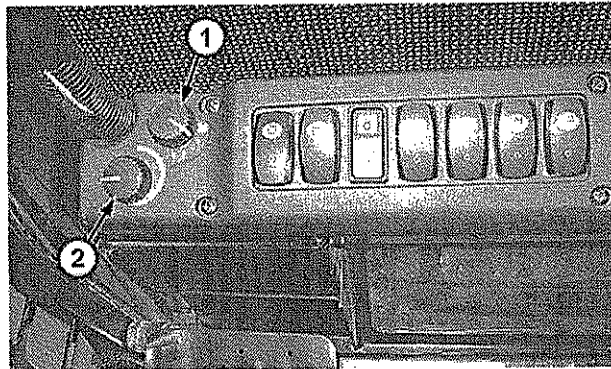

T199131A —JUN—12APR04

TX14740,0000126 -19-23JAN08-1/1

Air Conditioning Controls—If Equipped

Push lower half of air conditioning switch (1) to turn air conditioning on.

Turn temperature control knob (2) counterclockwise to decrease temperature.

Turn blower switch (3) clockwise to increase blower speed.

1— Air Conditioning Switch 2— Temperature Control Knob
3— Blower Switch

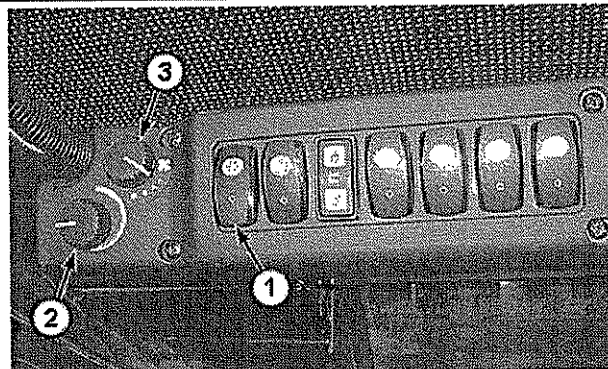

T199132A —JUN—12APR04

TX14740,0000127 -19-23JAN08-1/1

Operation—Operator's Station

Rear Window (Secondary Exit)

Push on bottom right corner (1) of window to force window out from molding.

1—Bottom Right Corner

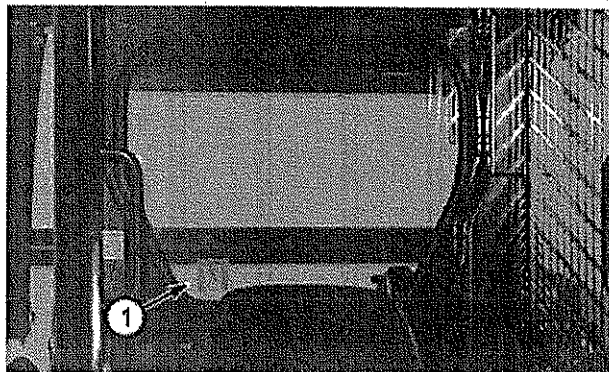

T189000B—UN—27MAR03

HG31779,0000225 -19-23JAN08-1/1

Seat Adjustment

1. Push lever (1) back.
2. Slide seat forward or backward to desired position.
3. Release lever.

1—Lever

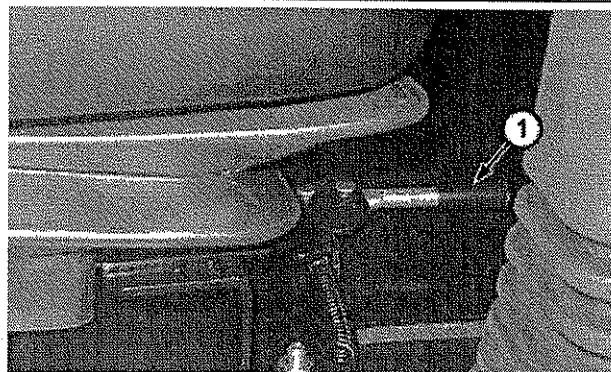

T189959B—UN—25MAR03

HG31779,0000226 -19-23JAN08-1/1

Suspension Seat Adjustment—If Equipped

1. Pull handle (1) out to adjust seat to weight of operator.
2. Turn handle clockwise for a heavier operator as indicated on the dial (2). Turn handle counterclockwise for a lighter operator as indicated on the dial.
3. Push handle underneath seat to store.

1—Handle

2—Dial

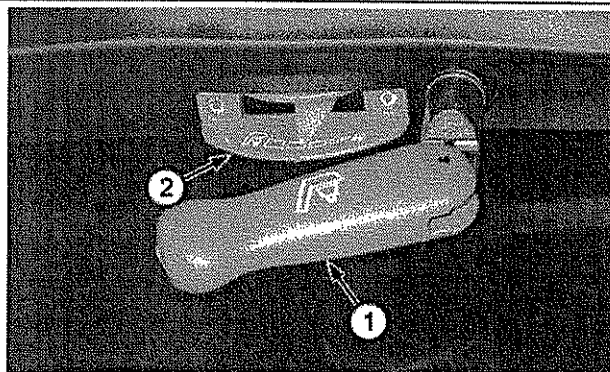

T189964B—UN—25MAR03

VD76477,0000099 -19-23JAN08-1/1

Adjusting Armrests - Hands Only and Hand-Foot Machines

1. Remove screws (1).
2. Adjust height of armrest.
3. Install screws.

Turn roller (2) toward the operator to lower front of armrest.
Turn roller away from operator to raise front of armrest.

1—Screws (2 used)

2—Roller

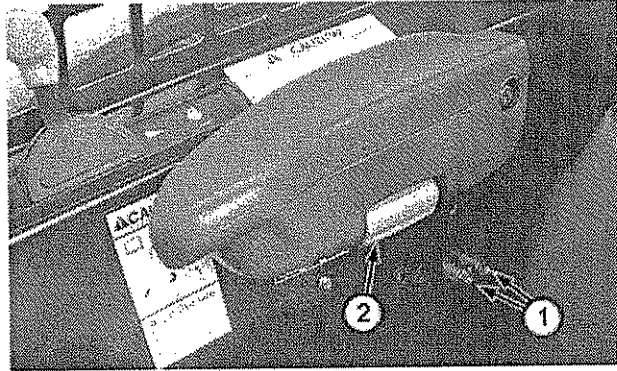

T1869386—JUN—26MAR03

HG31779,000022A -19-08JAN08-1/1

Beacon—If Equipped

Beacon light (1) is located on the top of operators station.
Beacon will be powered by the key switch and will be on whenever the key switch is on.

1—Beacon Light

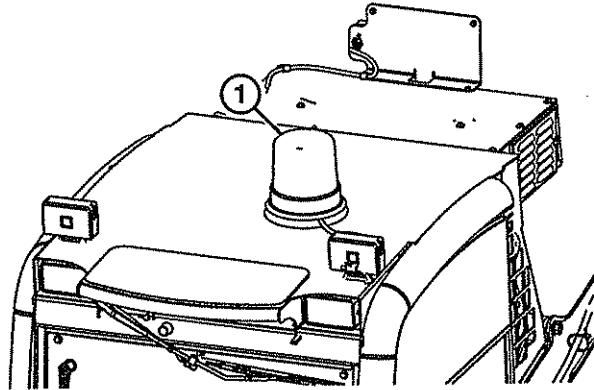

Beacon Light

TX1053162—JUN—16DEC08

CP94658,0000186 -19-05JAN09-1/1

Operation—Operating the Machine

Before Starting Work

Review the operating precautions. See Safety-Operating Precautions. (Section 1-3.)

Use seat belt when operating machine. Remember to fasten seat belt even during brief periods of use.

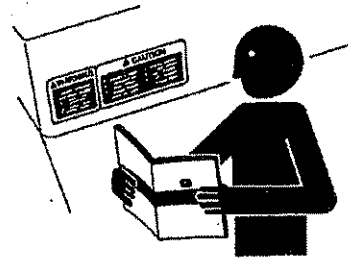

T133556—JUN—24AUG00

DW90712,00005E8 -19-22MAR07-1/1

Operator's Daily Machine Check Before Starting

Safety and Protective Device Checks

Walk around machine to clear all persons from machine area before starting machine.

Check condition of guards, shields, and covers.

Overall Machine Checks

Check for worn or frayed electrical wires and loose or corroded connections.

Check for bent, broken, loose, or missing boom, bucket, or sheet metal parts.

Check for loose or missing hardware.

Check for oil leaks, missing or loose hose clamps, kinked hoses, and lines or hoses that rub against each other or other parts.

TX14740,00000D7 -19-08FEB08-1/1

Entering Skid Steer

CAUTION: Prevent possible injury when entering and exiting machine. Always maintain a three-point contact. Do not use controls as handholds.

Entering the machine from the side or the front without a bucket attached: Use the boom step (1) and handholds (2) and (3).

Entering the machine from the front with a bucket attached: Use step (4) on back of bucket and handholds (2) and (3).

Entering the machine when the boom is raised on the boom lock:

1. Enter from the front.
2. Use handholds (3).
3. Step over the toe guard (5).

Exiting the machine:

CAUTION: Avoid possible injury from unexpected boom movement. Always lower boom to the ground or onto boom lock. Always engage the park brake, and stop the engine before exiting the machine.

1. Engage park brake.
2. Use the handholds for support. Step onto the boom step or bucket step and then onto the ground.

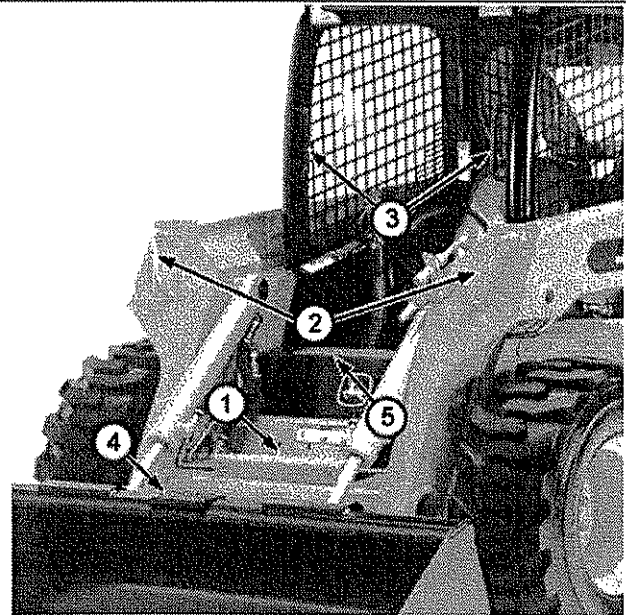

1— Boom Step
2— Boom Handholds
3— Operator's Station Handholds

4— Bucket Step
5— Toe Guard

T189022B—JUN—27MAR03

VD76477,000009A -19-20MAR07-1/1

Starting the Engine

1. Fasten seat belt.
2. Be sure all drive and auxiliary hydraulic controls are in neutral.
3. Engage park brake.
4. Push engine speed control lever (1) forward to 1/3 position.
5. Turn key switch to run position, but do not crank engine.
6. Check instrument panel. Engine low oil pressure indicator will be lit until engine starts:

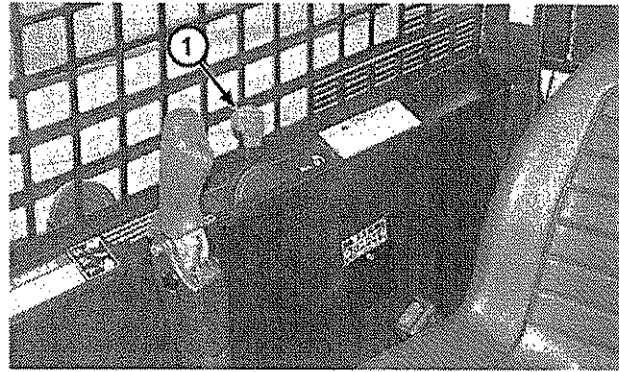

T163263B—UN—25APR02

1— Engine Speed Control Lever

IMPORTANT: Avoid possible machine damage. Do not crank starter continuously for more than 30 seconds or you may damage starter.

Do not use ether or any other type of starting fluid on engines.

Do not tow the machine to start it, or damage to hydrostatic system will occur.

IMPORTANT: To prevent damage of hydraulics and engine in temperatures below 0°C (32°F), run engine at low idle for 10 minutes before operating controls.

7. Turn key switch to start position.
8. Release key when engine starts. If engine does not start within 30 seconds, turn key switch to off position and allow starter to cool for 1 minute before trying again.
 - a. A warning light bulb check is performed each time machine is started.
9. Run at 1/3 speed for 30 seconds. Do not run at fast or slow idle. Do not accelerate rapidly during warm-up.
10. Operate machine at less-than-normal loads and speeds until engine is at normal operating temperature.

b. Always allow engine to warm up before applying a load.

DW90712,00001D2 -19-13JAN09-1/1

Cold Weather Starting

NOTE: It is normal for battery voltage indicator to light when glow plugs are active.

IMPORTANT: Avoid possible machine damage. Do not crank starter continuously for more than 30 seconds, or the starter may be damaged.

Do not use ether or any other type of starting fluid on engines.

Do not tow the machine to start it, or damage to hydrostatic system will occur.

IMPORTANT: To prevent damage to hydraulics and engine in temperatures below 0°C

(32°F), run engine at low idle for 10 minutes before operating controls.

1. Turn key switch to run position. If hydraulic oil temperature is below 16°C (60°F), glow plug light will stay on for 20 seconds as indicated by indicator light on monitor.
2. After glow plug light goes off, turn key switch to the start position.

VD76477,0000082 -19-28AUG07-1/1

Engine Block Heater—If Equipped

CAUTION: Prevent possible injury from electrical shock. Use grounded cord and inspect for damage before connecting to power source.

IMPORTANT: Prevent property damage as a result of possible fire from an overheated electrical cord. Use a heavy-duty, grounded cord to connect heater to electrical power.

Supply voltage for engine block heater can be 220 V or 110 V. Ensure the correct engine block heater is used for the correct supply voltage.

Engine block heater allows for quick starts and warmups during cold weather.

Connect engine block heater (1) to electrical power 10 hours before starting engine.

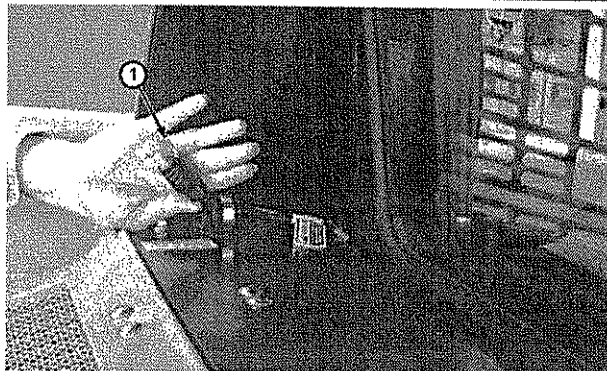

1— Engine Block Heater

T153157B—JUN—19AUG02

CP94658,000016F -19-29DEC08-1/1

Diesel Fired Coolant Heater Operation—If Equipped

CAUTION: Risk of fire or explosion. Diesel fired coolant heater must be turned off while refueling.

Risk of asphyxiation. Diesel fired coolant heater must not be operated in garages or enclosed areas.

NOTE: Heater must be off to change timer or activate any buttons.

NOTE: Heater can be set for three switch-on times within next 24 hours or one switch-on time within 7 days. Only one switch-on time can be activated at any given time.

1. To select and activate a memory setting press preset button (2) until desired memory location is shown.
 - First Memory- Press preset button once
 - Memory Display: 1 Basic
 - Second Memory- Press preset button twice
 - Memory Display: Secondary
 - Third Memory Display- Press preset button three times
 - Memory display: Secondary

Set Preheat Times into Memory

2. Using setting forward (5) or setting backward (4) buttons set desired time of day. When time stops flashing time is set.
3. Using setting forward or setting backward buttons set desired day of week. When day of week stops flashing day is set.

NOTE: A flashing heat button (3) indicates an activated memory.

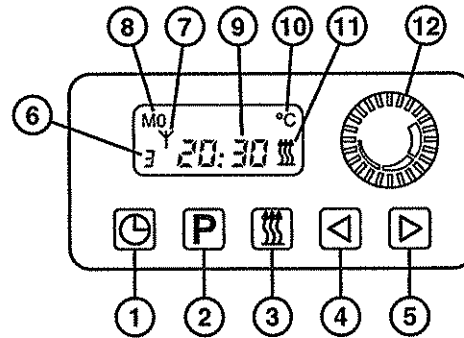

Timer Display

- | | |
|---------------------|--|
| 1— Actual Time | 7— Symbol for Radio Remote Control |
| 2— Preset Button | 8— Weekday or Preset Time |
| 3— Heat Button | 9— Current Time or Preset Time |
| 4— Setting Backward | 10— Temperature Display (air heater only) |
| 5— Setting Forward | 11— Operating Display |
| 6— Memory Display | 12— Temperature Preselection (air heater only) |

To use Preheat Start Time

4. To use preset start time press preset button until memory appears on display. Heater will start at date and time displayed.

NOTE: Preset button must be pushed each day to activate next start in preset memory.

Turn Heater OFF - All Modes

5. To turn heater off press heater button once. Heat signal to heater will be turned OFF, and heater will do a normal cool down cycle.

TF44157,0000BCC -19-09JAN09-1/1

Engine Warm-Up

1. Start engine. Run at 1/3 speed for 30 seconds. Do not run at fast or slow idle. Do not accelerate rapidly during warm-up.
2. Operate machine at less-than-normal loads and speeds until engine is at normal operating temperature.

HG31779,000022C -19-27MAR03-1/1

Self-Leveling—If Equipped

If machine is equipped with self leveling option, the attachment will remain in same relative position as the boom is raised.

- Self leveling is only operational during boom raise function.

- To override self leveling feature, use bucket pedal or hand control (if equipped).
- If you wish to disable self leveling feature contact your authorized dealer.

DW90712,0000149 -19-27JUN06-1/1

Using Attachment Mounting System—Quik-Tatch™

CAUTION: Prevent possible injury from unexpected machine movement. Be careful not to pinch hands between latch handle and step or latch handle and attachment. **DO NOT** try to latch or unlatch handles from operator's station.

To prevent injury from unexpected movement of the attachment, lower lift arms fully before engaging or disengaging attachment engagement pins. Ensure the pins are fully engaged before operating loader.

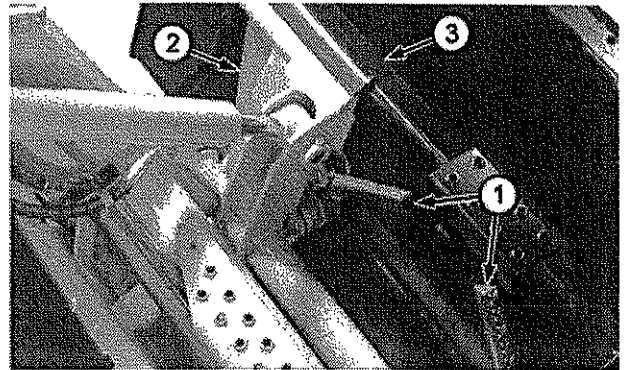

T153161B —JN—25APR02

Installing an attachment:

1. Park machine on level surface.
2. Lift latch handles (1) up to unlatched position. Be sure latch handles are all the way up so lock pins are fully retracted.
3. Enter machine, and fasten seat belt. Start engine. Disengage park brake.
4. Tilt mounting plates (2) forward.
5. Drive forward. Raise boom, and guide top of mounting plates under attachment mounting brackets (3).
6. Raise and roll back mounting plates. The back of attachment should rest against front of mounting plate.
7. When attachment is fully supported, lower boom until boom is resting on boom stops.
8. Roll attachment out, stopping with bottom edge of attachment about 50 mm (2 in.) from ground.
9. Engage park brake, stop engine, and exit machine.

1— Latch Handles
2— Mounting Plates

3— Mounting Brackets

Continued on next page

VD76477,000009B -19-17JAN08-1/2

Operation—Operating the Machine

10. Push the two latch handles (1) down to lock attachment to Quik-Tatch™.
11. Enter machine, and fasten seat belt.
12. Start engine, and disengage park brake.
13. Activate boom cylinders to raise attachment and extend bucket cylinders to tilt attachment at a slight downward angle so that bottom of Quik-Tatch is visible.
14. Visually inspect attachment mechanism to verify that pins are fully engaged in slots on back of attachment.

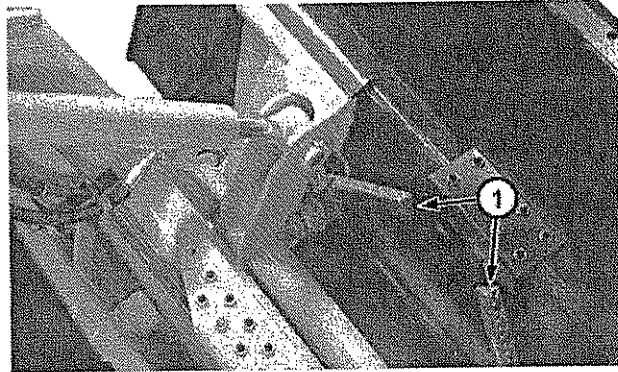

T189030B—UN—27MAR03

CAUTION: Prevent possible injury from unexpected movement of the attachment. Be sure pins and latch handles are secure before operating boom and bucket.

If attachment is not securely latched, follow the removal procedure, and then repeat installation procedure.

IMPORTANT: Avoid excessive pin wear. Keep the pin area clear of dirt and debris. Service as required if the pin will not fully engage or if wear is detected.

15. Connect hydraulic hoses if attachment is so equipped.

Removing the attachment:

1. Park machine.

CAUTION: Prevent possible crushing injury from falling attachment. Be sure attachment is on the ground before continuing.

Quik-Tatch is a trademark of Deere & Company

1— Latch Handles

2. Disconnect hydraulic hoses from attachment if so equipped.
3. Pull latch handles up to unlatched position to release pins from lower attachment tabs. Be sure latch handles are fully raised.
4. Enter machine, and fasten seat belt.
5. Start engine, and disengage park brake.
6. Lower attachment so that it rests securely on ground.
7. Tilt mounting plate forward, and back machine away from attachment at the same time.

VD76477,000009B -19-17JAN08-2/2

Boom Lock

Boom lock is used whenever it is necessary to leave machine with boom in a raised position.

Locking boom in raised position:

1. Remove any attachment.
2. Park machine on level surface.
3. Raise boom a short distance above boom lock.
4. Slide lever (1) away from seat to extend boom lock to locked position.
5. Slowly lower boom onto lock.

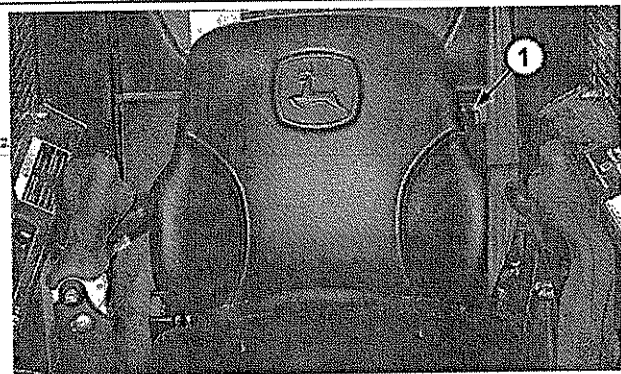

T199135A—UN—12APR04

1— Boom Lock Lever

Disengaging boom lock:

1. Raise boom a short distance off of lock.
2. Slide lever toward seat to retract the boom lock to the unlocked position.
3. Slowly lower boom to the ground.

TX14740,00000B1 -19-20MAR07-1/1

Boom Release—Standard Controls

Boom release mechanism is to be used when boom is in a partially raised position and engine is stopped and will not start.

CAUTION: Prevent possible injury from unexpected boom movement. Never exit machine with boom raised unless boom is resting on boom lock.

1. Fasten seat belt.
2. Turn key switch to run position. Do not start engine.
3. Cycle park brake to middle position.
4. Pull handle (1) and hold.
5. Lower boom.

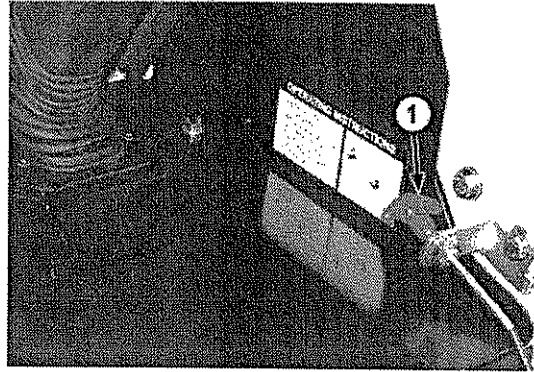

1— Handle

VD76477,0000088 -19-17JAN08-1/1

T153480B—UN—25APR02

Steering Levers—Hands Only and Hand-Foot Machines

NOTE: The right steering lever (2) controls right drive tracks, and the left steering lever (3) controls left drive tracks:

Activate the steering control levers:

- Push both levers forward at the same time to go forward.
- Pull both levers back at the same time to go backward.
- Push one lever forward and pull the other lever back at the same time to make a short turn.
- Slowly return levers to middle (neutral) position to stop.

1— Engine Speed Control
Lever

2— Right Steering Lever

3— Left Steering Lever

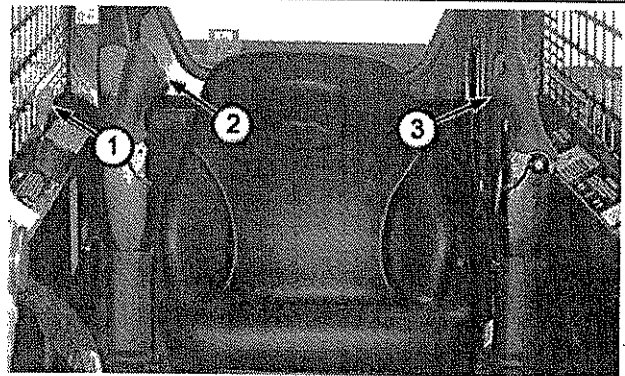

VD76477,0000075 -19-10APR07-1/1

T180056B—UN—28MAR03

Operating Auxiliary Hydraulics—Hand-Foot Machines

1. Turn locking mechanism (1) to right to unlock auxiliary hydraulics handle (2) from neutral position. Turn locking mechanism to left to lock handle in neutral position.
2. Pivot handle down toward seat to supply oil to male quick coupler (3). Pulling handle all the way down toward seat will put control valve into detent position to give continuous oil flow to an attachment. The handle will stay in this position until operator moves handle.
3. Pivot handle up away from seat to supply oil to female quick coupler (4), reversing flow.

IMPORTANT: Handle must be locked in neutral when auxiliary hydraulics are not in use to prevent overheating of hydraulic oil.

NOTE: If handle has not been moved all the way down into detent position, it will automatically return to center position when operator lets go.

- | | |
|--------------------------------|-------------------------|
| 1— Locking Mechanism | 3— Male Quick Coupler |
| 2— Auxillary Hydraulics Handle | 4— Female Quick Coupler |

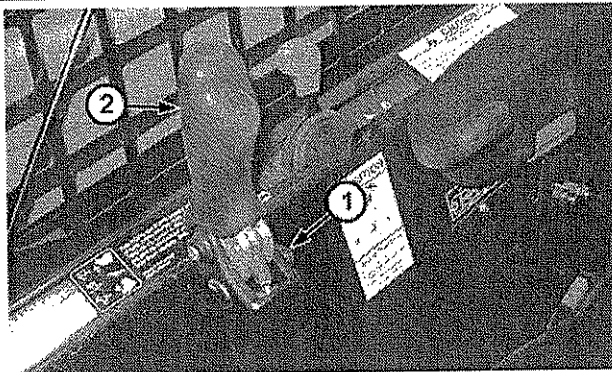

T189071B —JUN—28MAR03

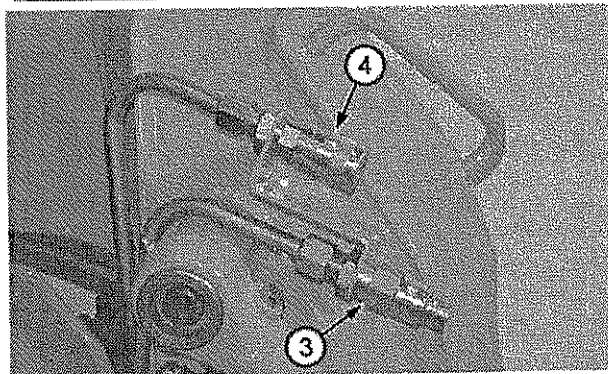

T153314B —JUN—25APR02

VD76477,0000083 -19-20MAR07-1/1

Operating Boom—Hand-Foot Machines

The left pedal (1) controls the boom:

- Push back of pedal down to raise boom.
- Push front of pedal down to lower boom.
- Boom will move faster the farther the pedal is pushed down.
- Pedal will return to neutral-hold position when released if not in float position.

Float Position:

Relieves down pressure on boom cylinders, and allows boom and attachment to float with contour of the ground.

- Push front of boom pedal down into detent position to engage float. Boom will stay in float until the rear of pedal is pushed down.

1—Left Pedal

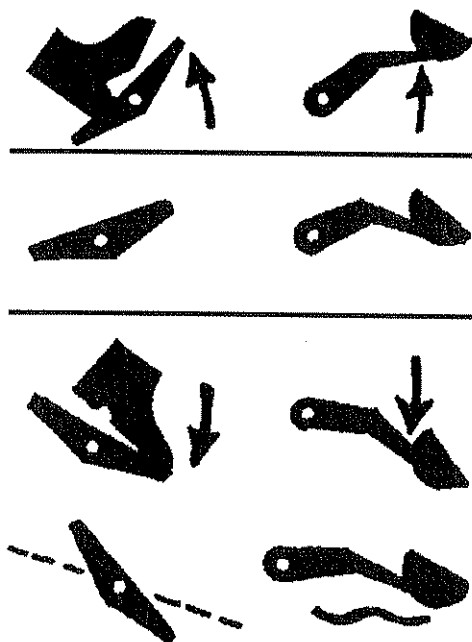
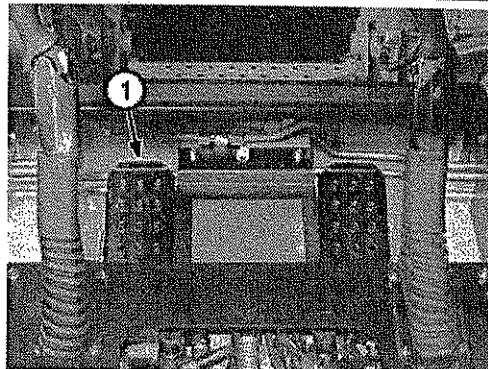

T15315B—UN—25APR02

T164304—UN—25APR02

T154305—UN—25APR02

VD76477,0000084 -19-14MAR07-1/1

Operating Bucket—Hand-Foot Machines

The right pedal (1) controls the bucket:

- Push back of pedal down to roll bucket back.
- Push front of pedal down to dump bucket.
- Bucket will move faster the farther the pedal is pushed down.
- Pedal will return to neutral-hold position when it is released.

1—Right Pedal

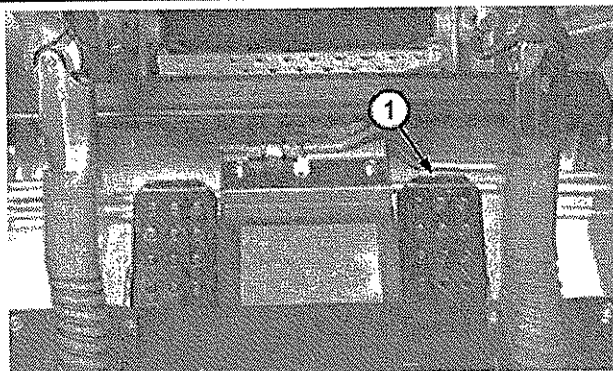

T193130A—JUN—26AUG03

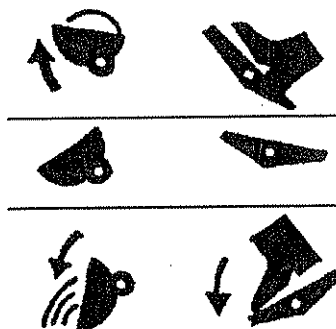

T164306—JUN—25APR02

TX14740,00000AF -19-31JAN07-1/1

Operating Auxiliary Hydraulics—Hands Only Machines

Unlocking right pedal (auxiliary hydraulics control):

- Push lockout handle (1) forward and rest in notch (2) labeled "Unlocked."

Locking right pedal in neutral position:

- Move lockout handle out of "Unlocked" position and pull rearward.

Activating auxiliary hydraulics:

- Push the front of the right pedal (3) down to supply oil to male quick coupler (5).
- Pushing front of right pedal down into detent will put control valve into detent position to give continuous flow to an attachment. The pedal will stay in this position until operator releases pedal.
- Push back of right pedal to supply oil to female quick coupler (4) reversing oil flow.

IMPORTANT: The auxiliary pedal lockout must be locked in neutral when auxiliary hydraulics are not in use to prevent overheating of hydraulic oil.

NOTE: If pedal has not been locked into detent position, it will automatically return to center position when operator releases pressure to pedal.

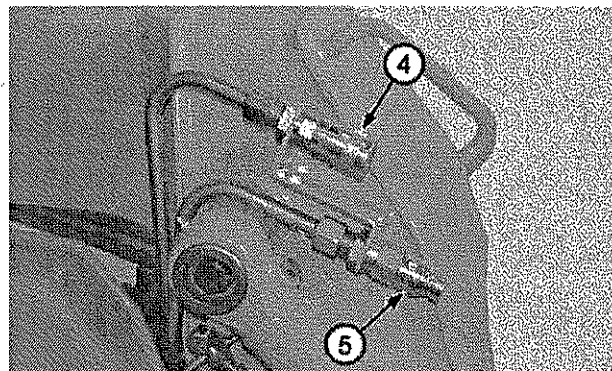
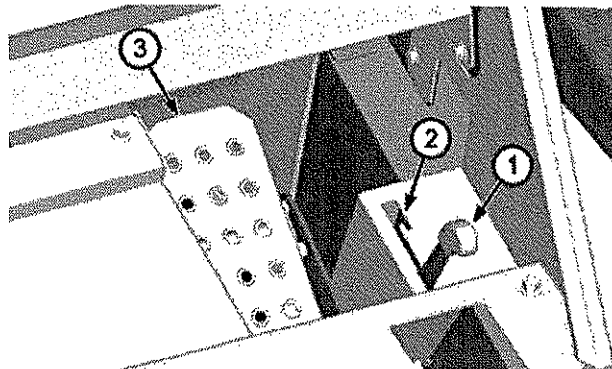

- | | |
|----------------------------------|------------------------|
| 1—Auxiliary Pedal Lockout Handle | 4—Female Quick Coupler |
| 2—"Unlocked" Notch | 5—Male Quick Coupler |
| 3—Right Pedal | |

TX14740,0000076 -19-04APR07-1/1

T153267B—UN—25APR02

T193131A—UN—26AUG03

Operating Boom and Bucket—Hands Only Machines

NOTE: The left pedal is non-functional. The right pedal is the auxiliary hydraulics control.

Activating bucket controls using right steering lever handle (2):

- Pivot handle left to roll back bucket.
- Pivot handle right to dump bucket.
- Bucket will move faster the farther the handle is moved.

Activating boom controls using left steering lever handle (3):

- Pivot handle left to raise boom.
- Pivot handle right to lower boom.
- Boom will move faster the farther the handle is moved.
- Push handle down toward seat and into detent position to engage float.

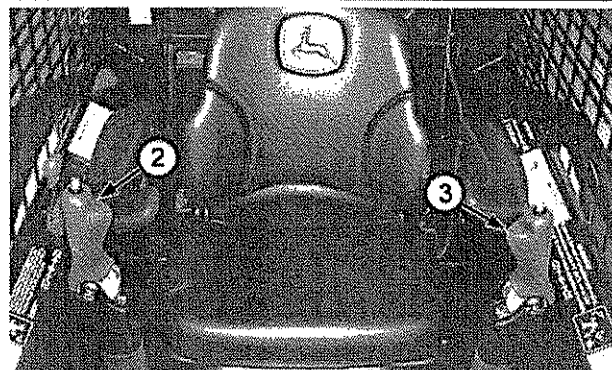

- | | |
|-------------------------------|------------------------------|
| 2—Right Steering Lever Handle | 3—Left Steering Lever Handle |
|-------------------------------|------------------------------|

HG31779,0000010 -19-31JAN07-1/1

T153258B—UN—25APR02

Using Attachment Mounting System—Hydraulic Quik-Tatch (S.N. — 131876)

Installing an attachment:

1. Park machine on level surface.
2. Lower boom until boom is resting on boom stops.
3. Disengage park brake.
4. Push and hold hydraulic Quik-Tatch switch in unlocked position until lock pins are fully retracted. Indicator window (1) should be completely red.
5. Tilt mounting plates (2) forward.
6. Drive forward and raise boom. Guide top of mounting plates under attachment mounting brackets.
7. Raise and rollback mounting plates. Back of attachment should rest against front of mounting plate.
8. Lower boom until boom is resting on boom stops when attachment is fully supported.
9. Roll attachment out. Stop with bottom edge of attachment 50 mm (2 in.) from ground.
10. Press and hold hydraulic Quik-Tatch switch in the locked position until lock pins are fully engaged. No red should be visible in indicator window.
11. Activate lift cylinders to raise attachment and extend bucket cylinders to tilt attachment at a slight downward angle so that the bottom of the Quik-Tatch is visible.
12. Visually inspect attachment mechanism to verify that pins are fully engaged in slots on back of attachment.

CAUTION: Prevent possible crushing injury from falling attachment. Be sure pins are engaged before operating boom and bucket. No red should be visible in the indicator window.

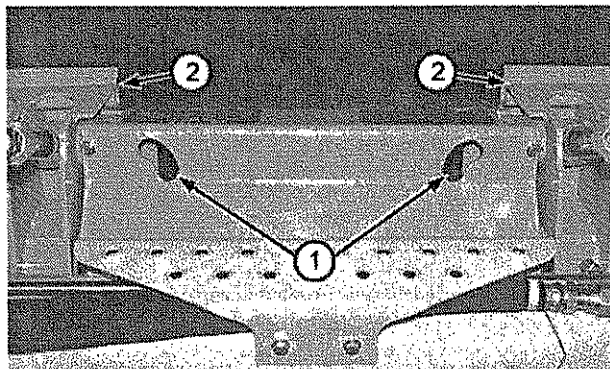

T1889073B—UN—28MAR03

1—Indicator Window

2—Tilt Mounting Plates

13. Connect hydraulic hoses of attachment (if equipped).

Removing the attachment:

1. Park machine on level surface.
2. Lower boom until attachment is securely resting on ground.
3. Engage park brake, and stop engine.
4. Disconnect hydraulic hoses from attachment (if equipped).
5. Fasten seat belt.
6. Start engine, and disengage park brake.
7. Push and hold hydraulic Quik-Tatch switch in unlocked position until lock pins are fully retracted. Indicator window on hydraulic Quik-Tatch should be completely red.
8. Tilt mounting plate forward, and back machine away from attachment at the same time.

DW90712,0000155 -19-31JAN07-1/1

Using Attachment Mounting System—Electric Quik-Tatch (S.N. 131877 —)

Installing an attachment:

1. Park machine on level surface.
2. Lower boom until boom is resting on boom stops.
3. Disengage park brake.
4. Push and hold electric Quik-Tatch switch in unlocked position until lock pins are fully retracted. Indicator window (1) should be completely red.
5. Tilt mounting plates (2) forward.
6. Drive forward and raise boom. Guide top of mounting plates under attachment mounting brackets.
7. Raise and rollback mounting plates. Back of attachment should rest against front of mounting plate.
8. Lower boom until boom is resting on boom stops when attachment is fully supported.
9. Roll attachment out. Stop with bottom edge of attachment 50 mm (2 in.) from ground.
10. Press and hold electric Quik-Tatch switch in the locked position until lock pins are fully engaged. No red should be visible in indicator window.
11. Activate lift cylinders to raise attachment and extend bucket cylinders to tilt attachment at a slight downward angle so that the bottom of the Quik-Tatch is visible.
12. Visually inspect attachment mechanism to verify that pins are fully engaged in slots on back of attachment.

CAUTION: Prevent possible crushing injury from falling attachment. Be sure pins are engaged before operating boom and bucket. No red should be visible in the indicator window.

13. Connect hydraulic hoses of attachment (if equipped).

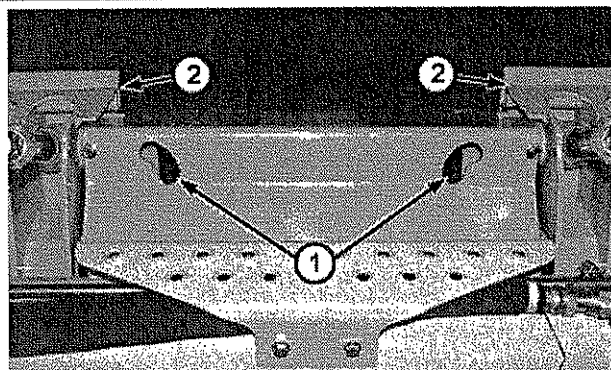

1—Indicator Window

2—Tilt Mounting Plates

Removing the attachment:

1. Park machine on level surface.
2. Lower boom until attachment is securely resting on ground.
3. Engage park brake, and stop engine.
4. Disconnect hydraulic hoses from attachment (if equipped).
5. Fasten seat belt.
6. Start engine, and disengage park brake.
7. Push and hold electric Quik-Tatch switch in unlocked position until lock pins are fully retracted. Indicator window on electric Quik-Tatch should be completely red.
8. Tilt mounting plate forward, and back machine away from attachment at the same time.

DW90712,0000156 -19-14MAR07-1/1

Stopping the Engine

1. Move steering levers to neutral position to stop machine.
2. Move auxiliary hydraulics handle to neutral position.
3. Pull engine speed control lever back to low idle.

CAUTION: Prevent possible injury from unexpected boom movement. Never exit machine with boom arms raised unless boom is resting on boom lock.

4. Lower boom completely to ground. If boom is to remain in raised position, use boom lock.
5. Engage park brake.
6. Pull engine speed control lever back to idle position.
7. Turn key switch to off position.
8. Release seat belt.

DW90712,00001D3 -19-09AUG06-1/1

Loading Machine On a Trailer

IMPORTANT: Avoid damage. Never put chains across bucket cylinders. Damage to cylinders may occur.

Do not tow machine or hydrostatic system damage may occur.

NOTE: Keep the ramps level, tracks and ramps should be clean. Use extra caution in wet or muddy conditions.

Use a heavy-duty trailer to transport machine. When loading machine onto a truck or trailer, keep boom and/or attachment down. Back machine onto a trailer. Before exiting machine, lower attachment to trailer bed, engage park brake, and shut off engine.

Fasten machine to trailer with heavy-duty straps, chains, or cables using tie down in front and in rear. Both front

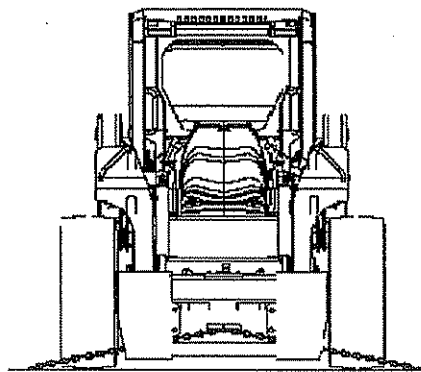

T189129—UN—03SEP03

and rear straps must be directed down and outward from machine. Trailer must have signs and lights required by law.

DW90712,00001D4 -19-09AUG08-1/1

Maintenance—Machine

Diesel Fuel

Consult your local fuel distributor for properties of the diesel fuel available in your area.

In general, diesel fuels are blended to satisfy the low temperature requirements of the geographical area in which they are marketed.

Diesel fuels specified to EN 590 or ASTM D975 are recommended. Renewable diesel fuel produced by hydrotreating animal fats and vegetable oils is basically identical to petroleum diesel fuel. Renewable diesel that meets EN 590 or ASTM D975 is acceptable for use at all percentage mixture levels.

Required Fuel Properties

In all cases, the fuel shall meet the following properties:

Cetane number of 45 minimum. Cetane number greater than 50 is preferred, especially for temperatures below -20°C (-4°F) or elevations above 1500 m (5000 ft).

Cold Filter Plugging Point (CFPP) should be at least 5°C (9°F) below the expected lowest temperature or **Cloud Point** below the expected lowest ambient temperature.

Fuel lubricity should pass a maximum scar diameter of 0.45 mm as measured by ASTM D6079 or ISO 12156-1.

Sulfur Content for Interim Tier 4 and EU Stage IIIB Engines

- Diesel fuel quality and fuel sulfur content must comply with all existing emissions regulations for the area in which the engine operates.
- Use **ONLY** ultra low sulfur diesel (ULSD) fuel with a maximum of 0.0015% (15 ppm) sulfur content.

Sulfur Content for Other Engines

- Diesel fuel quality and fuel sulfur content must comply with all existing emissions regulations for the area in which the engine operates.
- Use of diesel fuel with sulfur content less than 0.10% (1000 ppm) is **STRONGLY** recommended.
- Use of diesel fuel with sulfur content 0.10% (1000 ppm) to 0.50% (5000 ppm) may result in **REDUCED** oil and filter change intervals as shown in the table.
- **BEFORE** using diesel fuel with sulfur content greater than 0.50% (5000 ppm), contact your John Deere dealer.

IMPORTANT: Do not mix used diesel engine oil or any other type of lubricating oil with diesel fuel.

Improper fuel additive usage may cause damage on fuel injection equipment of diesel engines.

DX,FUEL1 -19-03NOV08-1/1

Biodiesel Fuel

Biodiesel is a fuel comprised of mono-alkyl esters of long chain fatty acids derived from vegetable oils or animal fats. Biodiesel blends are biodiesel mixed with petroleum diesel fuel on a volume basis.

Biodiesel users in the U.S. are strongly encouraged to purchase biodiesel blends from a BQ-9000 Certified Marketer and sourced from a BQ-9000 Accredited Producer (as certified by the National Biodiesel Board). Certified Marketers and Accredited Producers can be found at the following website: <http://www.bq-9000.org>.

While 5% blends are preferred (B5), biodiesel concentrations up to a 20% blend (B20) in petroleum diesel fuel can be used in all John Deere engines. Biodiesel blends up to B20 can be used ONLY if the biodiesel (100% biodiesel or B100) meets ASTM D6751 (US), EN 14214 (EU), or equivalent specification. Expect a 2% reduction in power and a 3% reduction in fuel economy when using B20.

John Deere approved fuel conditioners containing detergent/dispersant additives are recommended when using lower biodiesel blends, but are required when using blends of B20 or greater.

John Deere engines can also operate on biodiesel blends above B20 (up to 100% biodiesel) ONLY if the biodiesel meets the EN 14214 specification (primarily available in Europe). Engines operating on biodiesel blends above B20 may not fully comply with all applicable emissions regulations. Expect up to a 12% reduction in power and an 18% reduction in fuel economy when using 100% biodiesel. John Deere approved fuel conditioners containing detergent/dispersant additives are required.

The petroleum diesel portion of biodiesel blends must meet the requirements of ASTM D975 (US) or EN 590 (EU) commercial standards.

Biodiesel blends up to B20 must be used within 90 days of the date of biodiesel manufacture. Biodiesel blends from B21 to B100 must be used within 45 days of the date of biodiesel manufacture.

Request a certificate of analysis from your fuel distributor to ensure that the fuel is compliant with the above specifications.

Consult your John Deere dealer for approved biodiesel fuel conditioners to improve storage and performance with biodiesel fuels.

When using biodiesel fuel, the engine oil level must be checked daily. If oil becomes diluted with fuel, shorten oil change intervals. Refer to Diesel Engine Oil and Filter Service Intervals for more details regarding biodiesel and engine oil change intervals.

The following must be considered when using biodiesel blends up to B20:

- Cold weather flow degradation
- Stability and storage issues (moisture absorption, oxidation, microbial growth)
- Possible filter restriction and plugging (usually a problem when first switching to biodiesel on used engines.)
- Possible fuel leakage through seals and hoses
- Possible reduction of service life of engine components

The following must also be considered when using biodiesel blends above B20.

- Possible coking and/or blocked injector nozzles, resulting in power loss and engine misfire if John Deere approved fuel conditioners containing detergent/dispersant additives are not used
- Possible crankcase oil dilution, requiring more frequent oil changes
- Possible corrosion of fuel injection equipment
- Possible lacquering and/or seizure of internal components
- Possible formation of sludge and sediments
- Possible thermal oxidation of fuel at elevated temperatures
- Possible elastomer seal and gasket material degradation (primarily an issue with older engines)
- Possible compatibility issues with other materials (including copper, lead, zinc, tin, brass, and bronze) used in fuel systems and fuel handling equipment
- Possible reduction in water separator efficiency
- Potential high acid levels within fuel system
- Possible damage to paint if exposed to biodiesel

IMPORTANT: Raw pressed vegetable oils are NOT acceptable for use as fuel in any concentration in John Deere engines. Their use could cause engine failure.

DX,FUEL7 -19-04OCT07-1/1

Low Sulfur Diesel Fuel Conditioner

When possible, use existing fuel formulations for engines used off-highway. This fuel will not require any additives to provide good performance and engine reliability. However, many local fuel distributors will not carry both low and regular sulfur diesel fuels.

If the local fuel distributor will supply only low sulfur fuel, order and use John Deere PREMIUM DIESEL FUEL

CONDITIONER. It provides lubricating properties along with other useful benefits, such as cetane improver, anti-oxidant, fuel stabilizer, corrosion inhibitor and others. John Deere PREMIUM DIESEL FUEL CONDITIONER is specifically for use with low sulfur fuels. Nearly all other diesel fuel conditioners only improve cold weather flow and stabilize long-term fuel storage. They do not contain the lubrication additives needed by rotary fuel injection pumps.

TX,45,JC2126 -19-15AUG97-1/1

Testing Diesel Fuel

DIESELSCAN™ is a John Deere fuel analysis program that can be used to monitor the quality of your fuel. The DIESELSCAN analysis verifies fuel type, cleanliness,

DIESELSCAN is a trademark of Deere & Company

water content, suitability for cold weather operation, and whether the fuel meets specifications.

Check with your John Deere dealer for availability of DIESELSCAN kits.

DX,FUEL6 -19-14NOV05-1/1

Handling and Storing Diesel Fuel

CAUTION: Handle fuel carefully. Do not fill the fuel tank when engine is running.

DO NOT smoke while you fill the fuel tank or service the fuel system.

Fill the fuel tank at the end of each day's operation to prevent water condensation and freezing during cold weather.

Keep all storage tanks as full as practicable to minimize condensation.

Ensure that all fuel tank caps and covers are installed properly to prevent moisture from entering.

Monitor water content of the fuel regularly.

When using bio-diesel fuel, the fuel filter may require more frequent replacement due to premature plugging.

Check engine oil level daily prior to starting engine. A rising oil level may indicate fuel dilution of the engine oil.

IMPORTANT: The fuel tank is vented through the filler cap. If a new filler cap is required, always replace it with an original vented cap.

When fuel is stored for an extended period or if there is a slow turnover of fuel, add a fuel conditioner to stabilize the fuel and prevent water condensation. Contact your fuel supplier for recommendations.

DX,FUEL4 -19-19DEC03-1/1

Alternative and Synthetic Lubricants

Conditions in certain geographical areas may require lubricant recommendations different from those printed in this manual. Some John Deere brand coolants and lubricants may not be available in your location.

Synthetic lubricants may be used if they meet the performance requirements as shown in this manual.

The temperature limits and service intervals shown in this manual apply to both conventional and synthetic oils.

Re-refined base stock products may be used if the finished lubricant meets the performance requirements.

IMPORTANT: Avoid mixing different brands or types of oils. Oil manufacturers blend base stock and additives to create their oils and to meet certain specifications and performance requirements. Mixing different oils can interfere with proper functioning of these formulations and degrade lubricant performance.

Consult your authorized dealer to obtain specific information and recommendations.

DW90712,000012F -19-01JUN06-1/1

Diesel Engine Oil

Use oil viscosity based on the expected air temperature range during the period between oil changes.

John Deere PLUS-50™ oil is preferred.

Oil meeting one of the following specifications are also recommended:

- ACEA Oil Sequence E7
- ACEA Oil Sequence E6
- ACEA Oil Sequence E5
- ACEA Oil Sequence E4

Extended service intervals may apply when John Deere PLUS-50™, ACEA E7, ACEA E6, ACEA E5, or ACEA E4 engine oils are used. Consult your John Deere dealer for more information.

Other oils may be used if they meet one or more of the following:

- John Deere TORQ-GARD SUPREME™
- API Service Category CJ-4
- API Service Category CI-4 PLUS
- API Service Category CI-4
- API Service Category CH-4
- ACEA Oil Sequence E3

Multi-viscosity diesel engine oils are preferred.

Diesel fuel quality and fuel sulfur content must comply with all existing emissions regulations for the area in which the engine operates.

*PLUS-50 is a trademark of Deere & Company
TORQ-GARD SUPREME is a trademark of Deere & Company*

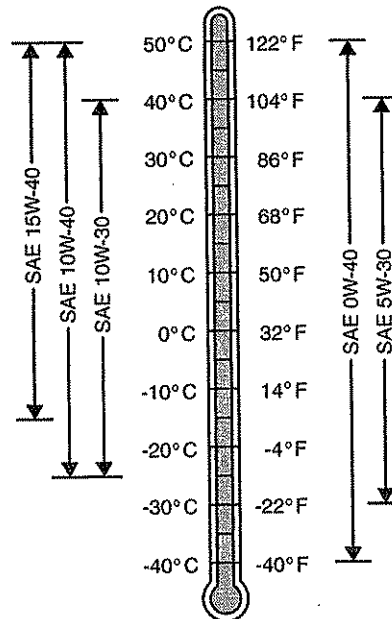

Oil Viscosities for Air Temperature Ranges

DO NOT use diesel fuel with sulfur content greater than 1.0% (10 000 ppm).

TS1689—UN—18JUL07

DX,ENOIL7 -19-06APR07-1/1

Diesel Engine Oil and Filter Service Intervals

The oil and filter service intervals in the following table should be used as guidelines. Actual service intervals also depend on operation and maintenance practices. It is suggested to use oil analysis to determine the actual useful life of the oil and to aid in selection of the proper oil and filter service interval.

Oil and filter service intervals are based on a combination of oil pan capacity, type of engine oil and filter used, and sulfur content of the diesel fuel.

Engine Oil and Filter Service Intervals		
	Standard Drain Oil Pan	Extended Drain Oil Pan
Fuel Sulfur	Less than 0.05% (500 ppm)	
Standard Oil	250 hours	250 hours
Premium Oil	375 hours	500 hours
Fuel Sulfur	0.05 to 0.50% (500 to 5000 ppm)	
Standard Oil	150 hours	150 hours
Premium Oil	275 hours	400 hours
Fuel Sulfur	0.50% to 1.00% (5000 ppm to 10 000 ppm)	
Standard Oil	125 hours	125 hours
Premium Oil	187 hours	250 hours
Engine oil analysis is required to determine the actual extended service life of premium oils ACEA E7, ACEA E6, ACEA E5, and ACEA E4.		

Diesel fuel sulfur level will affect engine oil and filter service intervals. Higher fuel sulfur levels reduce oil and filter service intervals as shown in the table.

- Use of diesel fuel with sulfur content less than 0.05% (500 ppm) is strongly recommended.
- Use of diesel fuel with sulfur content 0.05% (500 ppm) to 0.50% (5000 ppm) may result in REDUCED oil and filter change intervals as shown in the table.

PLUS-50 is a trademark of Deere & Company
 TORQ-GARD SUPREME is a trademark of Deere & Company

- BEFORE using diesel fuel with sulfur content greater than 0.50% (5000 ppm), contact your John Deere dealer.

IMPORTANT: When using biodiesel blends greater than B20, reduce the oil and filter service interval by 50% or monitor engine oil based on test results from OILSCAN.

Oil types (premium or standard) in the table include:

- "Premium Oils" include John Deere PLUS-50™, ACEA E7, ACEA E6, ACEA E5, or ACEA E4 oils.
- "Standard Oils" include John Deere TORQ-GARD SUPREME™, API CJ-4, API CI-4 PLUS, API CI-4, API CH-4, or ACEA E3 oils.

NOTE: The 500 hour extended oil and filter change interval is only allowed if all of the following conditions are met:

- Engine equipped with an extended drain interval oil pan
- Use of diesel fuel with sulfur content less than 0.05% (500 ppm)
- Use of premium oil: John Deere PLUS-50, ACEA E7, ACEA E6, ACEA E5, or ACEA E4
- Perform engine oil analysis to determine the actual extended service life of ACEA E7, ACEA E6, ACEA E5, and ACEA E4 oils
- Use of an approved John Deere oil filter

Hydraulic and Hydrostatic Oil

Use oil viscosity based on the expected air temperature range during the period between oil changes.

The following oil is preferred:

- John Deere PLUS-50™

The following oil is also recommended:

- John Deere TORQ-GARD™

Other oils may be used if they meet one or more of the following:

- API Service Classification CH-4
- API Service Classification CG-4

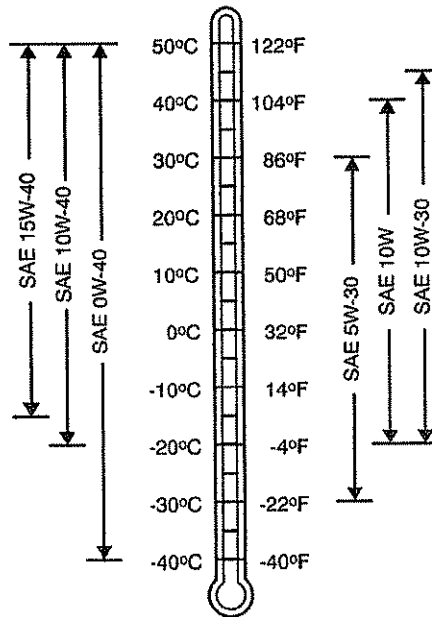

T148385—UN—19NOV01

PLUS-50 is a trademark of Deere & Company
TORQ-GARD is a trademark of Deere & Company

TX14740,000014A -19-14JUN04-1/1

Chain Case Oil

Use oil viscosity based on the expected air temperature range during the period between oil changes.

NOTE: Factory fill is SAE 10W-30. Do not mix with other oils.

The following oils are preferred:

- John Deere HY-GARD™
- John Deere Low Viscosity HY-GARD™
- John Deere PLUS-50™
- John Deere TORQ-GARD™

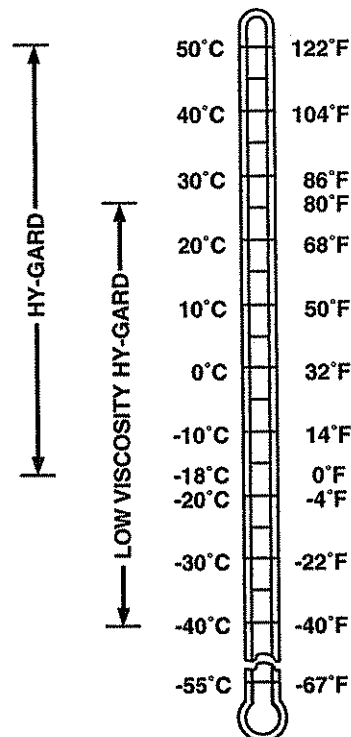

T184402—UN—02SEP03

HY-GARD is a trademark of Deere & Company
PLUS-50 is a trademark of Deere & Company
TORQ-GARD is a trademark of Deere & Company

TX14740,00000AE -19-17SEP04-1/1

Grease

Use grease based on NLGI consistency numbers and the expected air temperature range during the service interval.

The following greases are preferred:

- John Deere MULTI-PURPOSES POLYUREA GREASE
- John Deere SPECIAL-PURPOSE HD MOLY GREASE

Other greases may be used if they meet the following:

- SAE Multipurpose EP Grease with a maximum of 5% molybdenum disulfide
- SAE Multipurpose EP Grease

Grease meeting Military Specification MIL-G-10924F may be used as arctic grease.

IMPORTANT: Some types of grease thickener are not compatible with others. Consult your grease supplier before mixing different types of grease.

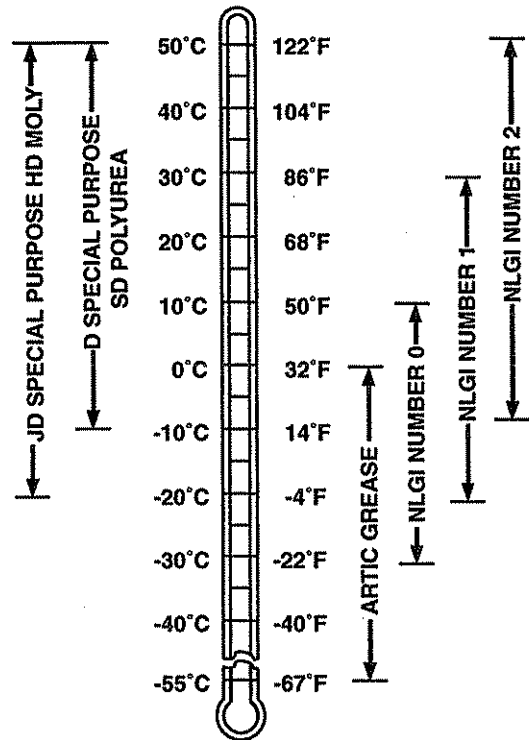

TX14740,00000AD -19-29JAN08-1/1

T194400—UN—02SEP03

Light Duty Diesel Engine Coolant (for diesel engines without wet sleeve cylinder liners)

The engine cooling system is filled to provide year-round protection against corrosion and cylinder liner pitting, and winter freeze protection to -37°C (-34°F). If protection at lower temperatures is required, consult your John Deere dealer for recommendations.

IMPORTANT: The following engine coolants are preferred:

- John Deere COOL-GARD™ II Premix
- John Deere COOL-GARD Premix
- John Deere COOL-GARD PG Premix

John Deere COOL-GARD II Premix and John Deere COOL-GARD Premix are available in a concentration of 50% ethylene glycol.

John Deere COOL-GARD PG Premix is available in a concentration of 55% propylene glycol.

Additional Recommended Coolants

The following engine coolants are also recommended:

- John Deere COOL-GARD II Concentrate in a 40% to 60% mixture of concentrate with quality water
- John Deere COOL-GARD Concentrate in a 40% to 60% mixture of concentrate with quality water

Other Coolants

Other ethylene glycol or propylene glycol base coolants may be used if they meet one of the following specifications:

- ASTM D3306 prediluted (50%) coolant
- ASTM D3306 coolant concentrate in a 40% to 60% mixture of concentrate with quality water

If these coolants are unavailable, use an engine coolant concentrate or prediluted coolant with a minimum of the following chemical and physical properties:

COOL-GARD is a trademark of Deere & Company

- Is formulated with a quality nitrite-free additive package
- Protects the cooling system metals (cast iron, aluminum alloys, and copper alloys such as brass) from corrosion

The coolant concentrate or prediluted coolant shall be of a quality that is suitable for all-aluminum engines.

Water Quality

Water quality is important to the performance of the cooling system. Distilled, deionized, or demineralized water is recommended for mixing with ethylene glycol base engine coolant concentrate.

Coolant Drain Intervals

Drain and flush the cooling system and refill with fresh coolant at the indicated interval, which varies with the coolant used.

When John Deere COOL-GARD II is used, the drain interval is 6 years or 6000 hours of operation.

When John Deere COOL-GARD is used, the drain interval is 5 years or 5000 hours of operation.

When John Deere COOL-GARD PG is used, the drain interval is 5 years or 5000 hours of operation.

If a coolant other than COOL-GARD II, COOL-GARD, or COOL-GARD PG is used, reduce the drain interval to 2 years or 2000 hours of operation.

IMPORTANT: Do not use cooling system sealing additives or antifreeze that contains sealing additives.

Do not mix ethylene glycol and propylene glycol base coolants.

DX,COOL18 -19-03NOV08-1/1

Drain Intervals for Diesel Engine Coolant

Drain and flush the cooling system and refill with fresh coolant at the indicated interval, which varies with the coolant used.

John Deere COOL-GARD™ II Premix and COOL-GARD II Concentrate are maintenance free coolants for up to 6 years or 6000 hours of operation, provided that the cooling system is topped off using only John Deere COOL-GARD II Premix. Test the coolant condition annually with Coolant Test Strips designed for use with John Deere COOL-GARD II coolants. If the test strip chart indicates that additive is required, add John Deere COOL-GARD II, COOLANT EXTENDER as directed.

When John Deere COOL-GARD Premix, COOL-GARD Concentrate or John Deere COOL-GARD PG Premix coolants are used, the drain interval may be extended to 5 years or 5000 hours of operation, provided that the coolant is tested annually AND additives are replenished, as needed, by adding a supplemental coolant additive.

If John Deere COOL-GARD II Premix or COOL-GARD II Concentrate is used, but the coolant is not tested OR

COOL-GARD is a trademark of Deere & Company

additives are not replenished by adding John Deere COOL-GARD II COOLANT EXTENDER, the drain interval is 4 years or 4000 hours of operation. This drain interval only applies to COOL-GARD II coolants that have been maintained within a 40% to 60% mixture of concentrate with quality water.

If John Deere COOL-GARD Premix, COOL-GARD Concentrate, or COOL-GARD PG Premix is used, but the coolant is not tested OR additives are not replenished by adding a supplemental coolant additive, the drain interval is 3 years or 3000 hours of operation. This drain interval only applies to COOL-GARD Premix, COOL-GARD Concentrate, and COOL-GARD PG Premix that have been maintained within a 40% to 60% mixture of concentrate with quality water.

If a coolant other than COOL-GARD II, COOL-GARD, or COOL-GARD PG is used, reduce the drain interval to 2 years or 2000 hours of operation.

DX,COOL11 -19-03NOV08-1/1

John Deere COOL-GARD™ II COOLANT EXTENDER

Some coolant additives will gradually deplete during engine operation. For John Deere COOL-GARD™ II Premix and COOL-GARD II Concentrate, replenish coolant additives between drain intervals by adding John Deere COOL-GARD II COOLANT EXTENDER.

John Deere COOL-GARD II COOLANT EXTENDER should not be added unless indicated by coolant testing.

John Deere COOL-GARD II COOLANT EXTENDER is a chemically matched additive system approved for use with John Deere COOL-GARD II coolants in all John Deere engines.

John Deere COOL-GARD II COOLANT EXTENDER is not designed for use with John Deere COOL-GARD coolants.

COOL-GARD is a trademark of Deere & Company

IMPORTANT: Do not add a supplemental coolant additive when the cooling system is drained and refilled with any of the following:

- John Deere COOL-GARD II
- John Deere COOL-GARD
- John Deere COOL-GARD PG

The use of non-recommended supplemental coolant additives may result in additive drop-out, gelation of the coolant, or corrosion of cooling system components.

Add the recommended concentration of John Deere COOL-GARD II COOLANT EXTENDER. DO NOT add more than the recommended amount.

DX,COOL16 -19-03NOV08-1/1

Supplemental Coolant Additives

Some coolant additives will gradually deplete during engine operation. For John Deere COOL-GARD™ Premix, COOL-GARD Concentrate, or John Deere COOL-GARD PG Premix, replenish coolant additives between drain intervals by adding a supplemental coolant additive as determined necessary by coolant testing.

John Deere LIQUID COOLANT CONDITIONER is recommended as a supplemental coolant additive for John Deere COOL-GARD Premix, COOL-GARD Concentrate, and COOL-GARD PG Premix.

John Deere LIQUID COOLANT CONDITIONER is not designed for use with COOL-GARD II Premix or COOL-GARD II Concentrate.

IMPORTANT: Do not add a supplemental coolant additive when the cooling system is drained and refilled with any of the following:

- John Deere COOL-GARD II
- John Deere COOL-GARD
- John Deere COOL-GARD PG

If other coolants are used, consult the coolant supplier and follow the manufacturer's recommendation for use of supplemental coolant additives.

The use of non-recommended supplemental coolant additives may result in additive drop-out and gelation of the coolant.

Add the manufacturer's recommended concentration of supplemental coolant additive. DO NOT add more than the recommended amount.

COOL-GARD is a trademark of Deere & Company

DX,COOL4 -19-03NOV08-1/1

Operating in Warm Temperature Climates

John Deere engines are designed to operate using glycol base engine coolants.

Always use a recommended glycol base engine coolant, even when operating in geographical areas where freeze protection is not required.

John Deere COOL-GARD™ II Premix is available in a concentration of 50% ethylene glycol. However, there are situations in warm temperature climates where a coolant with lower glycol concentration (approximately 20% ethylene glycol) has been approved. In these cases, the low glycol formulation has been modified to provide the same level of corrosion inhibitor as John Deere COOL-GARD II Premix (50/50).

COOL-GARD is a trademark of Deere & Company

IMPORTANT: Water may be used as coolant in emergency situations only.

Foaming, hot surface aluminum and iron corrosion, scaling, and cavitation will occur when water is used as the coolant, even when coolant conditioners are added.

Drain cooling system and refill with recommended glycol base engine coolant as soon as possible.

DX,COOL6 -19-03NOV08-1/1

Additional Information About Diesel Engine Coolants and John Deere COOL-GARD™ II COOLANT EXTENDER

Engine coolants are a combination of three chemical components: ethylene glycol or propylene glycol antifreeze, inhibiting coolant additives, and quality water.

Coolant Specifications

John Deere COOL-GARD™ II Premix is a fully formulated coolant that contains all three components in their correct concentrations. DO NOT add an initial charge of John Deere COOL-GARD II COOLANT EXTENDER to COOL-GARD II Premix. DO NOT add any other supplemental coolant additive or water to COOL-GARD II Premix.

John Deere COOL-GARD II Concentrate contains both ethylene glycol and inhibiting coolant additives. Mix this product with quality water, but DO NOT add an initial charge of John Deere COOL-GARD II COOLANT EXTENDER or any other supplemental coolant additive.

Replenish Coolant Additives

Some coolant additives will gradually deplete during engine operation. Periodic replenishment of inhibitors is required, even when John Deere COOL-GARD II Premix or COOL-GARD II Concentrate is used. Follow the recommendations in this manual for the use of John Deere COOL-GARD II COOLANT EXTENDER.

Why use John Deere COOL-GARD II COOLANT EXTENDER?

Operating without proper coolant additives will result in increased corrosion, cylinder liner erosion and pitting, and other damage to the engine and cooling system. A simple mixture of ethylene glycol or propylene glycol and water will not give adequate protection.

John Deere COOL-GARD II COOLANT EXTENDER is a chemically matched additive system designed to fortify the proprietary additives used in John Deere COOL-GARD II Premix and COOL-GARD II Concentrate and to provide optimum protection for up to 6 years or 6000 hours of operation.

COOL-GARD is a trademark of Deere & Company

Avoid Automotive-type Coolants

Never use automotive-type coolants (such as those meeting ASTM D3306). These coolants do not contain the correct additives to protect heavy-duty diesel engines. Do not treat an automotive engine coolant with supplemental coolant additives because the high concentration of additives can result in additive fallout.

Water Quality

Water quality is important to the performance of the cooling system. Distilled, deionized, or demineralized water is recommended for mixing with ethylene glycol and propylene glycol base engine coolant concentrate. All water used in the cooling system should meet the following minimum specifications for quality:

Chlorides	<40 mg/L
Sulfates	<100 mg/L
Total dissolved solids	<340 mg/L
Total hardness	<170 mg/L
pH	5.5 to 9.0

Freeze Protection

The relative concentrations of glycol and water in the engine coolant determine its freeze protection limit.

Ethylene Glycol	Freeze Protection Limit
40%	-24°C (-12°F)
50%	-37°C (-34°F)
60%	-52°C (-62°F)
Propylene Glycol	Freeze Protection Limit
40%	-21°C (-6°F)
50%	-33°C (-27°F)
60%	-49°C (-56°F)

DO NOT use a coolant-water mixture greater than 60% ethylene glycol or 60% propylene glycol.

DX,COOL17 -19-03NOV08-11

Testing Diesel Engine Coolant

Maintaining adequate concentrations of glycol and inhibiting additives in the coolant is critical to protect the engine and cooling system against freezing, corrosion, and cylinder liner erosion and pitting.

Test the coolant solution at intervals of 12 months or less and whenever excessive coolant is lost through leaks or overheating.

Coolant Test Strips

Coolant test strips are available from your John Deere dealer. These test strips provide a simple, effective method to check the freeze point and additive levels of your engine coolant.

When Using John Deere COOL-GARD II

John Deere COOL-GARD™ II Premix and COOL-GARD II Concentrate are maintenance free coolants for up to 6 years or 6000 hours of operation, provided that the cooling system is topped off using only John Deere COOL-GARD II Premix coolant. Test the coolant condition annually with coolant test strips designed for use with John Deere

*COOL-GARD is a trademark of Deere & Company
CoolScan is a trademark of Deere & Company
CoolScan PLUS is a trademark of Deere & Company*

COOL-GARD II coolants. If the test strip chart indicates that additive is required, add John Deere COOL-GARD II COOLANT EXTENDER as directed.

Add only the recommended concentration of John Deere COOL-GARD II COOLANT EXTENDER. DO NOT add more than the recommended amount.

When Using John Deere COOL-GARD

Compare the test strip results to the supplemental coolant additive (SCA) chart to determine the amount of inhibiting additives in your coolant and whether more John Deere LIQUID COOLANT CONDITIONER should be added.

Add only the recommended concentration of John Deere LIQUID COOLANT CONDITIONER. DO NOT add more than the recommended amount.

CoolScan and CoolScan PLUS

For a more thorough evaluation of your coolant, perform a CoolScan™ or CoolScan PLUS™ analysis, where available. See your John Deere dealer for information.

DX,COOLS -19-03NOV08-1/1

Maintenance—Periodic Maintenance

Service Machine at Specified Intervals

Lubricate and make service checks and adjustments at intervals shown on the periodic maintenance chart (A) and on the following pages.

Perform service on items at multiples of the original requirement. For example, at 500 hours, also service those items, if applicable, listed under 250 hours, 100 hours, 50 hours, and 10 hours or daily.

TX17994,0000268 -19-14MAR07-1/1

Fuel Tank

CAUTION: Handle fuel carefully. If the engine is hot or running, **DO NOT** fill the fuel tank. **DO NOT** smoke while filling fuel tank or working on fuel system.

To avoid condensation, fill the fuel tank at the end of each day's operation. Shut off engine before filling.

Specification

Fuel Tank—Capacity..... 60.6 L
16.0 gal

TX14740,000010A -19-14MAR07-1/1

Raising and Blocking Machine

1. Park machine
2. Use a safe lifting device to raise machine. Use lifting points (1) to raise machine.
3. Lower machine onto blocks.

1— Lifting Points

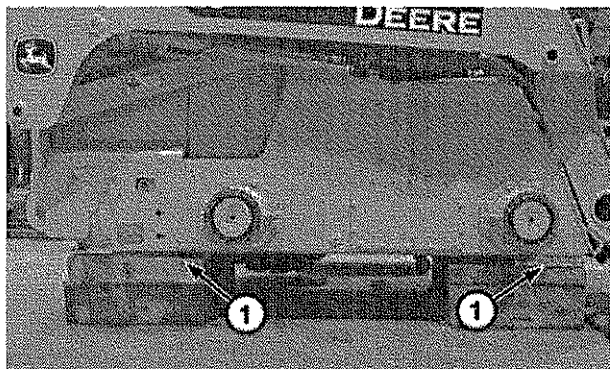

TX1035166A—UN—21JAN08

VD76477,000009E -19-22JAN08-1/1

Opening and Closing Rear Service Door

1. Park machine.
2. Pull latch (1) up to release door. Pull back on door to open it.
3. To close door, push door closed until latch closes.

NOTE: A padlock may be used to lock engine compartment.

1— Latch

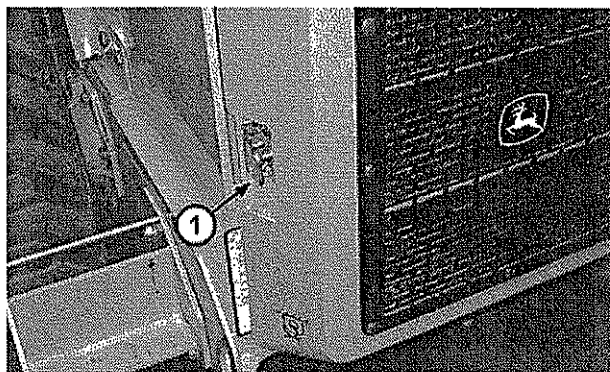

T198149A—UN—12APR04

DW90712,00001CC -19-09AUG06-1/1

Opening and Closing Engine Cover

1. Park machine.
2. Open rear service door.
3. Lift engine cover latch (1) up to release latch.
4. Open engine cover.

Closing engine cover:

- Lower cover letting latch slide into slots on each side.

1—Latch

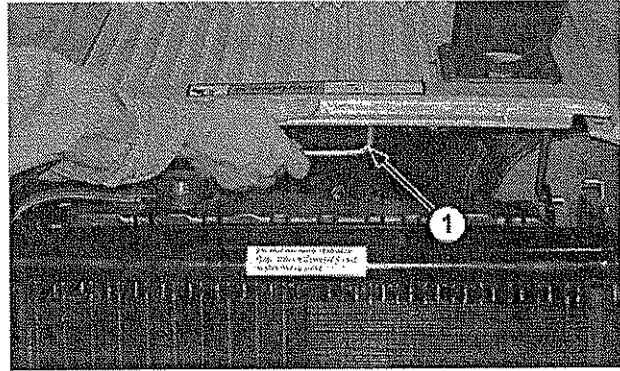

TT154203B—JUN—06AUG02

DW90712,00001CD -19-31JAN07-1/1

Removing Side Panels

1. Park machine.
2. Open rear service door and engine cover.
3. Lift side panels up and remove from machine.

TX14740,0000132 -19-22MAR07-1/1

Raising Operator's Station

CAUTION: Prevent crushing injury from falling attachment. If machine is equipped with a demolition door or cab enclosure, it will be necessary to do the following:

Raise boom, engage boom lock, and rest boom on boom lock.

Open cab/demolition door.

1. Park machine on level surface, shut off engine.

NOTE: Operator's station can be raised with the boom resting on boom lock.

2. Remove nuts (1) (one on each side).
3. Using hand holds, raise operator's station, making sure steering levers fall forward. Continue raising operator's station all the way up so that gas spring cylinder locks are in place.
4. Ensure operator's station cylinder is locked by pulling forward on red cylinder lock (2).
5. To lower operator's station, push red cylinder lock (3) rearward to unlock cylinder.
6. Pull operator's station down until seated on mounting studs.

CAUTION: Prevent crushing injury from unexpected cab movement. Replace gas spring cylinder if:

Cylinder is cracked or damaged.

The operator's station is hard to lift.

NOTE: See your authorized dealer. NEVER attempt to repair a damaged gas spring cylinder.

7. Install washer and nut on operator's station mounting stud (one on each side). Tighten hardware to specification.

Specification

Mounting Stud	
Hardware—Torque.....	140 N·m 105 lb-ft

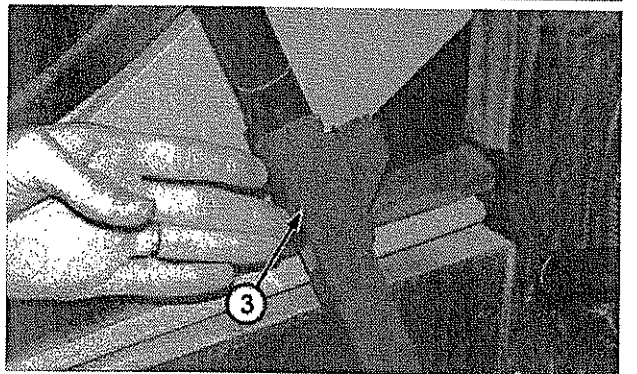
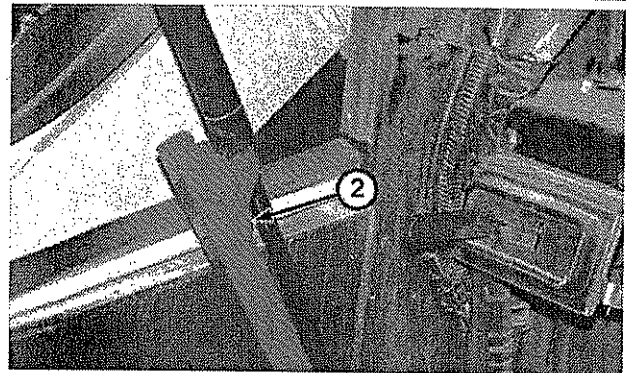
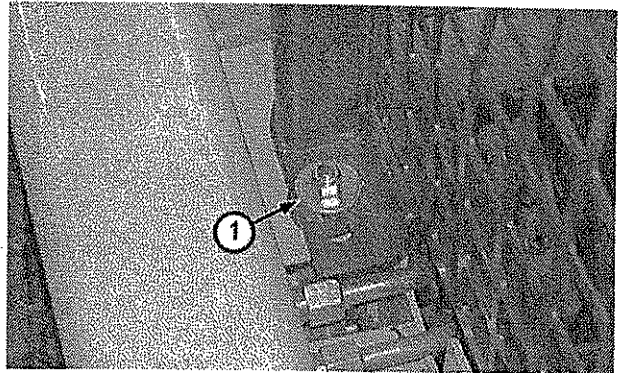

- 1—Nut
- 2—Cylinder Lock (locked position)
- 3—Cylinder Lock (unlocked position)

8. Disengage boom lock and lower boom.

VD76477,0000073 -19-09JAN09-1/1

T154659A —UN—22SEP03

T154210B —UN—06AUG02

T154211B —UN—06AUG02

Removing Cover Plates

1. Park machine on level surface.
2. Remove any attachment.
3. Raise boom and set on boom lock.
4. Turn key switch to off position.
5. Raise and lock operator's station in up position.
6. Remove toe guard shielding (1).
7. Remove step (2) and cover (3).

1—Toe Guard Shielding 3—Cover
2—Step

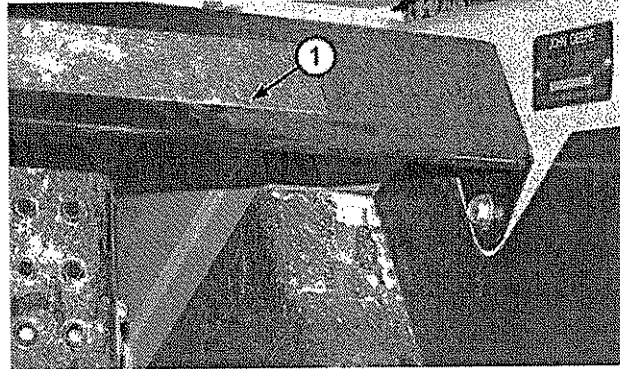

T154204B—UN—19AUG02

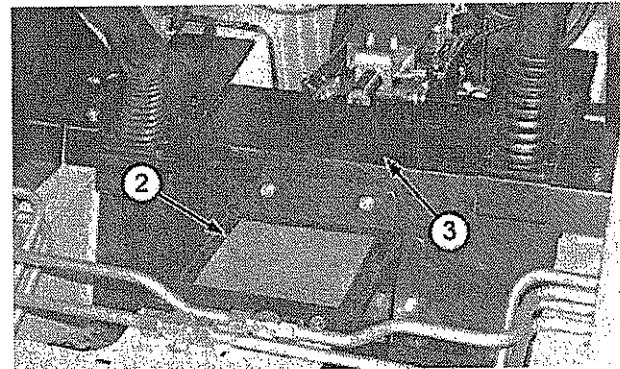

T154205B—UN—06AUG02

HG31779,0000059 -19-31JAN07-1/1

Maintenance and Repair Record Keeping System

The checklist in this section summarizes scheduled maintenance, and parts and oil required at each maintenance interval.

Use the checklist to:

- Remind operator to perform machine maintenance at specified intervals to minimize downtime.
- Calculate cost of machine operation and ownership allowing operator to make better job estimates.
- Place yourself in a stronger position at trade-in time.
- Satisfy your SECURE contract requirements.

As maintenance is performed, check off each item on the list and record date and hour meter reading.

Do not tear out or mark on checklist in this section; keep it to make extra copies.



MAINTENANCE AND REPAIR RECORD KEEPING SYSTEM FOR JOHN DEERE MACHINE OWNERS

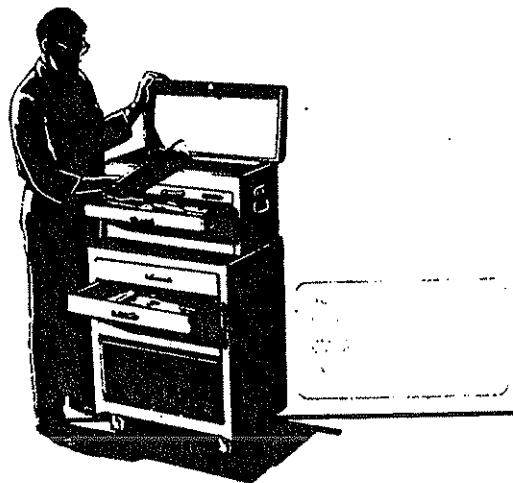

T7511CO—UN—27JUN91

DW90712,00001CE -19-14MAR07-1/1

Fluid Analysis Program Test Kits and 3-Way Coolant Test Kit

Fluid Analysis Program Test Kits and the 3-Way Coolant Test Kit are John Deere fluid sampling products to help you monitor machine maintenance and system condition. The objective of a fluid sampling program is to ensure machine availability when you need it and to reduce repair costs by identifying potential problems before they become critical.

Engine, hydraulic, power train, and coolant samples should be taken from each system on a periodic basis, usually prior to a filter and/or fluid change interval. Certain systems require more frequent sampling. Consult your authorized John Deere dealer on a maintenance program for your specific application. Your authorized John Deere dealer has the sampling products and expertise to assist

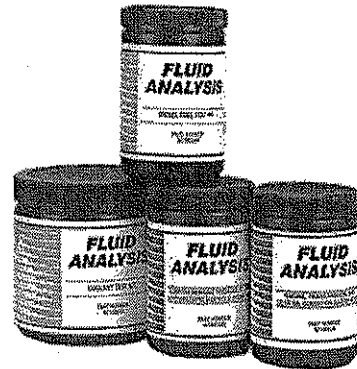

you in lowering your overall operating costs through fluid sampling.

AM40430,00002FE -19-12DEC08-1/1

TX1003513A—UN—20FEB06

Maintenance—Periodic Maintenance

Service Intervals

Model: 317 and 320 Skid Steer	Customer: _____
PIN/Serial Number: _____	Delivery Date: _____
SERVICE INTERVALS	
Service machine at intervals shown on this chart. Also, perform service on items at multiples of the original requirement. For example, at 500 hours also service those items (if applicable) listed under 250 hours, 50 hours, and 10 hours or daily.	
As Required	
<input type="checkbox"/> Add coolant extender as indicated by COOL-GARD™ II test strips	
Every 10 Hours or Daily	
<input type="checkbox"/> Check engine oil level	<input type="checkbox"/> Check radiator coolant level
<input type="checkbox"/> Check hydraulic tank oil level	<input type="checkbox"/> Drain fuel water separator filter
<input type="checkbox"/> Clean radiator and oil cooler	<input type="checkbox"/> Check or drain auxiliary water separator fuel filter—if equipped
Every 50 Hours	
<input type="checkbox"/> Lubricate boom linkage and cylinder pivot points	<input type="checkbox"/> Check tire pressure
OIL SAMPLING	
Take oil samples from each system before its recommended drain or change interval indicated on this form: 250, 500, 1000, and 2000 hours. Maintenance recommendations supplied by Oilscan is provided based upon the oil analysis and operating information you supply. Regular oil sampling extends the operational life of machine systems.	
Every 250 Hours	
<input type="checkbox"/> Check wheel lug nut torque	<input type="checkbox"/> Change engine oil and replace filter
<input type="checkbox"/> Take engine oil sample	
Every 500 Hours	
<input type="checkbox"/> Replace in-line fuel filter	<input type="checkbox"/> Replace hydraulic oil tank breather element
<input type="checkbox"/> Replace fuel water separator filter	<input type="checkbox"/> Replace hydraulic oil filter
<input type="checkbox"/> Replace primary air cleaner element	<input type="checkbox"/> Check chain case oil level
<input type="checkbox"/> Check battery water level	<input type="checkbox"/> Change engine oil and replace filter
<input type="checkbox"/> Take gearbox oil sample	<input type="checkbox"/> Take axle oil sample
<input type="checkbox"/> Take engine coolant sample	<input type="checkbox"/> Take diesel fuel sample
<input type="checkbox"/> Take transmission oil sample	<input type="checkbox"/> Take hydraulic oil sample
<input type="checkbox"/> Lubricate steering linkage	<input type="checkbox"/> Lubricate foot pedals
<input type="checkbox"/> Replace auxiliary water separator fuel filter—if equipped	
Every 1000 Hours	
<input type="checkbox"/> Replace secondary air cleaner element	<input type="checkbox"/> Change hydraulic tank oil
<input type="checkbox"/> Change chain case oil	<input type="checkbox"/> Check coolant
Every 6000 Hours	
<input type="checkbox"/> Drain, flush, and refill cooling system	

COOL-GARD is a trademark of Deere & Company

CP94658,0000170 -19-02MAR09-1/1

Maintenance—Periodic Maintenance

Required Parts

Description	Part Number	Every 250 Hours	Every 500 Hours	Every 1000 Hours	Every 6000 Hours
Engine Oil Filter	RE519626	1	1	1	1
In-line Fuel Filter	AT322654		1	1	1
Fuel Water Separator Filter	RE508202		1	1	1
Auxiliary Water Separator Fuel Filter—If Equipped	AT366222		1	1	1
Primary Air Cleaner Element	KV16428		1	1	1
Hydraulic Oil Tank Breather Element	AT101565		1	1	1
Hydraulic System Return Oil Filter	AT314164		1	1	1
Secondary Air Cleaner Element	AP33331			1	1
PLUS-50™ Oil (engine)	TY25851*	9.0 L (2.4 gal)	9.0 L (2.4 gal)	9.0 L (2.4 gal)	9.0 L (2.4 gal)
PLUS-50™ Oil (hydraulic tank)	TY25851*			19.0 L (5 gal)	19.0 L (5 gal)
PLUS-50™ Oil (chain case only)	TY25851*			28.8 L (7.6 gal)	28.8 L (7.6 gal)
Coolant Extender	TY26603	As Needed			
COOL-GARD™ II Pre-Mix	TY26575				6.6 L (1.8 gal)
Fluid Analysis Kits					
DieselScan™	AT180344		1	1	1
Hydraulic & Hydrostatic Oil	AT303189		1	1	1
Diesel Engine Oil	AT317904	1	1	1	1
COOLSCAN PLUS™ Kit	AT183016		1	1	1
COOL-GARD™ II Test Strips	TY26605			1	1

IMPORTANT: If fuel sulfur content exceeds 0.5 percent change the engine oil at 1/2 the normal interval. If engine has not run 250 hours before the season changes, change oil.

* For recommended oil types and oil viscosities based on operating temperatures, see Maintenance-Machine. (Section 3-1.)

PLUS-50 is a trademark of Deere & Company
 COOL-GARD is a trademark of Deere & Company
 DieselScan is a trademark of Deere & Company
 COOLSCAN PLUS is a trademark of Deere & Company

CP94658,0000171 -19-17FEB09-1/1

Drain Fuel Water Separator Filter

1. Park machine.
2. Open rear service door and engine cover, and remove left side panel.
3. Place a small container under fuel water canister (1).
4. Loosen valve (2) to drain fuel.
5. When fuel or water has drained, tighten valve.
6. Install side panel.
7. Close engine cover and rear service door.
8. Dispose of waste properly.

1—Fuel Water Canister 2—Valve

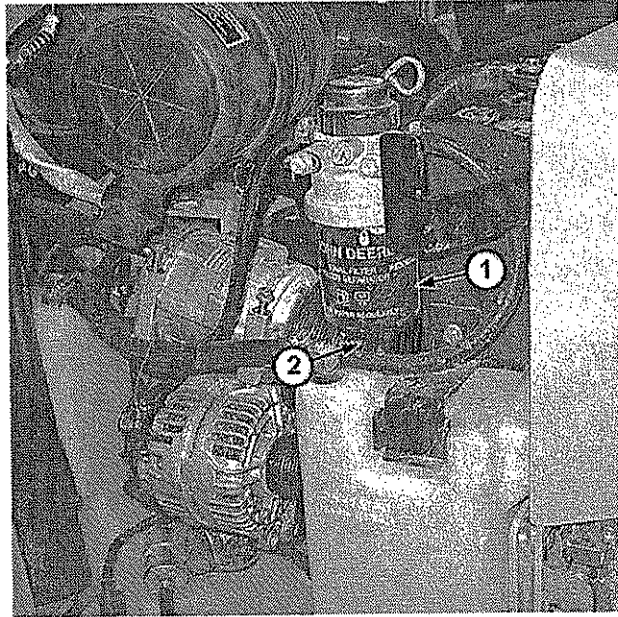

T199185A—UN—13APR04

VD76477,000007A -19-10APR07-1/1

Check Auxiliary Water Separator Fuel Filter—If Equipped

1. Place container under drain plug (3).
2. Loosen air vent (2) and drain plug. Drain water and sediment into container.
3. Tighten drain plug.
4. Bleed fuel system with fuel priming pump button (1), until air is vented.
5. Tighten air vent.
6. Operate engine and check for leaks.

1—Fuel Priming Pump Button (hand operated) 3—Drain Plug
2—Air Vent

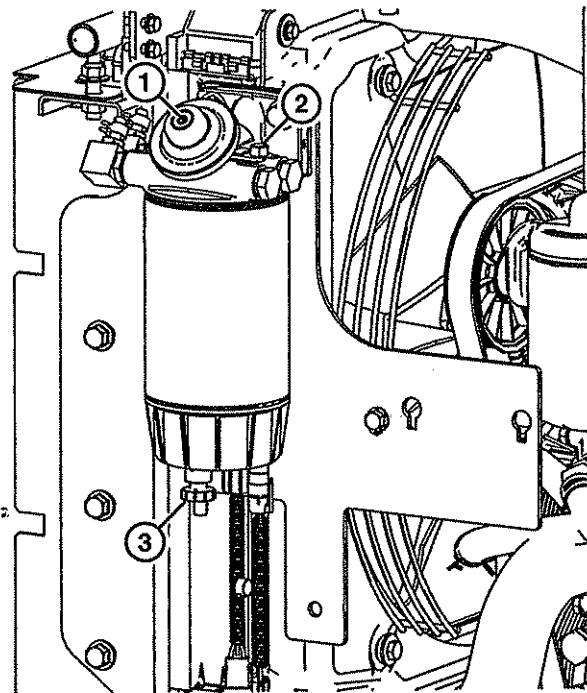

TX1053384—UN—19DEC08

Auxiliary Water Separator Fuel Filter

CP94658,0000174 -19-18DEC08-1/1

Maintenance—Every 50 Hours

Lubricate Boom Linkage, Cylinder Pivots, and Quik-Tatch™

NOTE: In severe operating conditions, Quik-Tatch™ linkage/pivot points (3) may need more frequent lubrication.

Lubricate pivot points (1), cylinders (2), and Quik-Tatch™ linkage/pivot points (3) on each side of boom every 50 hours with one or two shots of John Deere grease.

1—Pivot Points
2—Cylinders

3—Quik-Tatch™ Linkage/Pivot Points

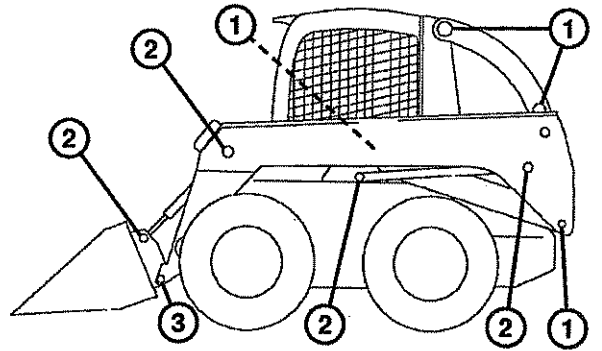

T194351—UN—02SEP03

Quik-Tatch is a trademark of Deere & Company

TX14740,00000AA -19-06FEB08-1/1

Check Tire Pressure

CAUTION: Explosive separation of a tire and rim parts can cause serious injury or death.

Always maintain the correct tire pressure. **DO NOT** inflate tires above the recommended pressure.

Inspect tires and wheels daily. **DO NOT** operate with low pressure, cuts, bubbles, damaged rims, or missing lug bolts.

Carefully inspect any tire and rim assembly that has been run flat or severely underinflated before reinflating the tire. Damage to the rim and tire may have developed. Call an authorized dealer or a qualified repair service technician to inspect the rim and tire assembly and make necessary repairs.

When inflating tires, use a clip-on chuck and extension hose long enough to allow adequate space to stand to one side and **NOT** in front of or over the tire assembly. Use a safety cage if available.

NEVER cut or weld on an inflated tire or rim assembly. Heat from welding could cause an increase in pressure and may result in tire explosion.

Do not attempt to mount a tire if you do not have the proper equipment and experience to perform the job. Have it done by an authorized dealer or a qualified repair service.

Check tire pressure with an accurate gauge having 7.0 kPa (0.07 bar) (1 psi) graduations.

1. Shut off air supply to hose.
2. Move gauge hand to correct pressure.
3. Lock air chuck on tire valve.
4. Turn on air supply. Stand to front or rear of tire when adding air to tire.

NOTE: Tire shipping pressure may not be the same as tire operating pressure. Tire pressures may be changed to suit working condition according to tire manufacturer's recommendations.

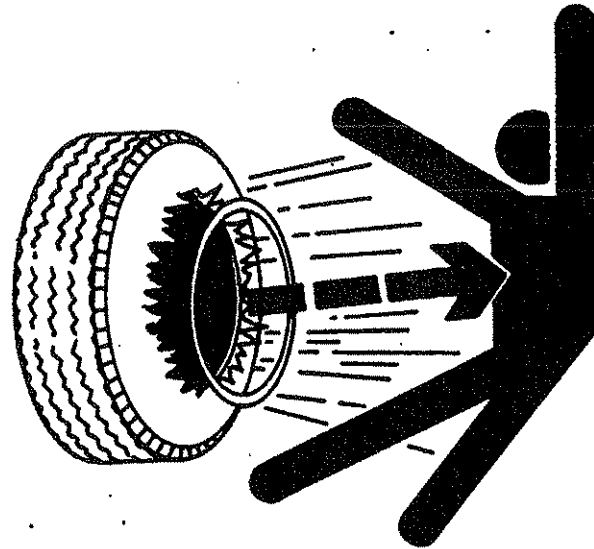

TS211—UN—23AUG88

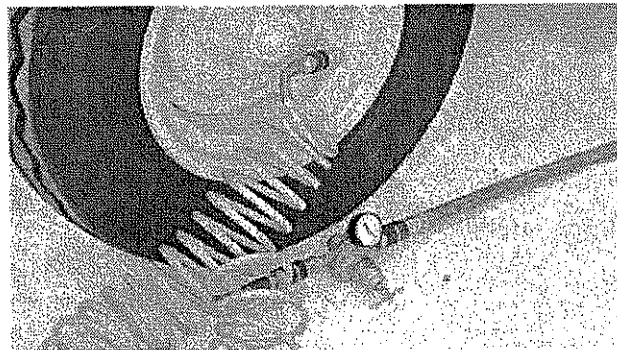

T87602—UN—21OCT88

*Tire Pressure (Cold Inflation) - 317

Item	Measurement	Specification
SKS - Extra-Wall 10 x 16.5	Pressure	379—414 kPa
		3.79—4.14 bar
		55—60 psi
12 x 16.5	Pressure	414—448 kPa
		4.14—4.48 bar
		60—65 psi

Continued on next page

DW90712,00001C7 -19-21MAR07-1/3

Maintenance—Every 50 Hours

Item	Measurement	Specification
SKS - Extra-Wall SKS - Hauler Heavy Duty 10 x 16.5	Pressure	379—414 kPa 3.79—4.14 bar 55—60 psi
12 x 16.5	Pressure	414—448 kPa 4.14—4.48 bar 60—65 psi
Galaxy - "Hippo" Flotation 31.5/1300 x 16.5	Pressure	241—414 kPa 2.41—4.14 bar 35—60 psi
Galaxy - "Beefy Baby II" Heavy Duty 10 x 16.5	Pressure	310—414 kPa 3.10—4.14 bar 45—60 psi
SuperFlex - Foam Filled Galaxy "Beefy Baby II" 10 x 16.5	Pressure	N/A N/A N/A
Mitco - "Duro Cushion" Solid 10 x 16.5	Pressure	N/A N/A N/A
Tire Pressure (Cold Inflation) - 320		
Item	Measurement	Specification
SKS - Standard Duty 12 x 16.5	Pressure	324—365 kPa 3.24—3.65 bar 47—53 psi
SKS - Extra-Wall 10 x 16.5	Pressure	379—414 kPa 3.79—4.14 bar 55—60 psi
12 x 16.5	Pressure	414—448 kPa 4.14—4.48 bar 60—65 psi
SKS - Hauler Heavy Duty 10 x 16.5	Pressure	379—414 kPa 3.79—4.14 bar 55—60 psi

Continued on next page

DW90712,00001C7 -19-21MAR07-2/3

Maintenance—Every 50 Hours

Item	Measurement	Specification
SKS - Standard Duty 12 x 16.5	Pressure	414—448 kPa 4.14—4.48 bar 60—65 psi
Galaxy - "Hippo" Flotation 31.5/1300 x 16.5	Pressure	241—414 kPa 2.41—4.14 bar 35—60 psi
33/1550 x 16.5	Pressure	241—414 kPa 2.41—4.14 bar 35—60 psi
Galaxy - "Beefy Baby II" Heavy Duty 10 x 16.5	Pressure	310—414 kPa 3.10—4.14 bar 45—60 psi
12 x 16.5	Pressure	276—448 kPa 2.76—4.48 bar 40—65 psi
SuperFlex - Foam Filled Galaxy "Beefy Baby II" 10 x 16.5	Pressure	N/A N/A N/A
12 x 16.5	Pressure	N/A N/A N/A
Mitco - "Duro Cushion" Solid 8 x 16	Pressure	N/A N/A N/A

DW90712,00001C7 -19-21MAR07-3/3

Maintenance—Every 250 Hours

Check Wheel Lug Nut Torque

Tighten wheel lug nuts.

Item	Measurement	Specification
Wheel Lug Nut	Torque	238 N·m 175 lb-ft

TX17994,0000308 -19-31JAN07-1/1

Change Engine Oil and Replace Filter

NOTE: Replace filter and change oil initially at 250 hours, then every 500 hours thereafter when using John Deere filter and PLUS-50™ oil.

1. Park machine.
2. Run engine a few minutes to warm oil.
3. Engage park brake and stop engine.
4. Remove access cover (1) on right side of machine to locate engine oil drain hose.
5. Remove plug using two wrenches to avoid twisting hose. Allow oil to drain into a suitable container. Dispose of waste oil properly.

NOTE: Make sure O-ring is still intact when installing hose plug.

6. After oil is drained, install hose plug.
7. Open rear service door and engine cover, and remove right side panel.
8. Clean dirt or debris from around engine oil filter (2). Remove oil filter.
9. Turn filter counterclockwise using a filter wrench to remove.
10. Apply a film of clean engine oil on seal of new filter.
11. Install filter. Turn filter until seal contacts mounting surface. Then turn filter by hand 2/3 to 1 turn more.
12. Remove engine oil filler cap (3).

IMPORTANT: Do not overfill. If overfilled, oil can cause engine damage.

13. Add oil. See Maintenance-Machine. (Section 3-1.)

Specification

Engine—Oil Capacity	
With Filter Change.....	9.0 L 2.4 gal

14. Check engine oil level.
15. Install and tighten filler cap.
16. Start engine, and run at slow speed for 2 minutes. Check for leaks around filter and drain plug.
17. Check engine oil level.

PLUS-50 is a trademark of Deere & Company

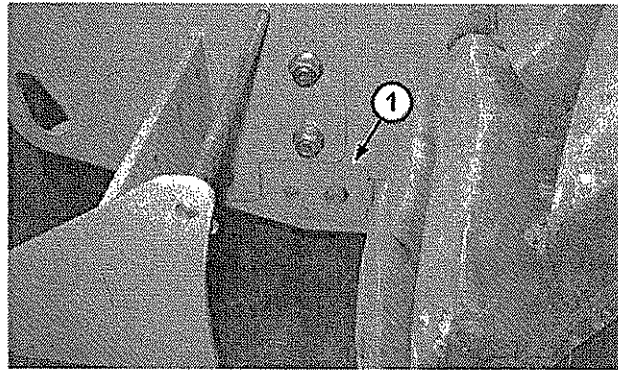

T198981A—JUN—06APR04

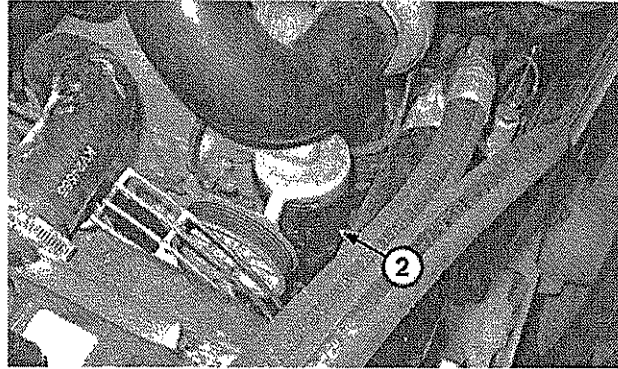

T198982A—JUN—06APR04

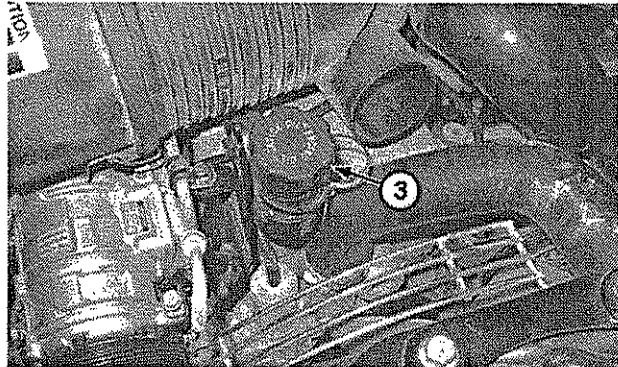

T198983A—JUN—06APR04

- 1—Access Cover
- 2—Engine Oil Filter
- 3—Engine Oil Filler Cap

18. Install access cover. Tighten cap screws.
19. Install side panel, and close engine door and rear service door.
20. Install access cover.

DW90712,0000121 -19-21MAR07-1/1

Maintenance—Every 500 Hours

Replace In-Line Fuel Filter

1. Park machine.
2. Open rear service door and engine cover.
3. Remove left side panel.
4. Loosen and slide hose clamps away from fuel filter (1). Remove hoses.
5. Remove fuel filter.
6. Install new filter.
7. Install hoses, and tighten clamps.
8. Install side panel, and close engine cover and rear service door.

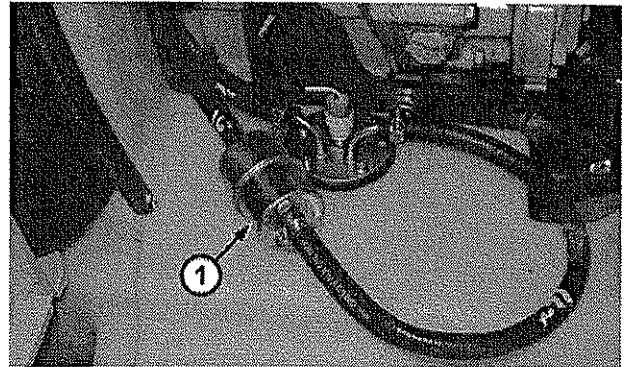

1—In-line Fuel Filter

T199023A—UN—06APR04

TX14740,000011C -19-21MAR07-1/1

Replace Fuel Water Separator Filter

1. Park machine.
2. Open rear service door and engine cover, and remove left side panel.
3. Drain fuel water separator. Dispose of waste properly.
4. Rotate canister (1) counterclockwise to remove canister and valve (2).
5. Insert new canister by aligning location tabs and pushing up to seat canister. Tighten canister.
6. Install side panel.
7. Close engine cover and rear service door.
8. Bleed fuel system.

1—Fuel Water Canister

2—Valve

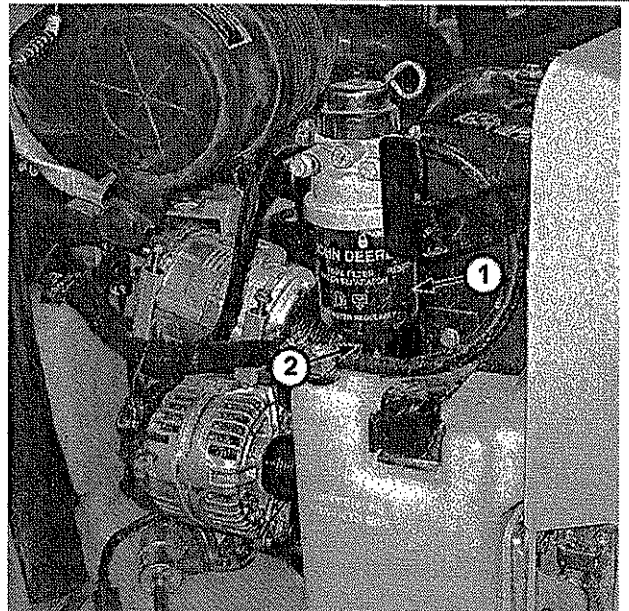

T199165A—UN—13APR04

VD76477,000008E -19-14MAR07-1/1

Bleed Fuel System

1. Open bleed screw (1) on fuel filter.
2. Pump primer (2) until fuel flows freely from bleed screw without air bubbles.
3. Tighten bleed screw.
4. Pump primer until a significant increase in resistance is felt, indicating fuel has filled the galley of the injection pump.

1—Bleed Screw

2—Primer

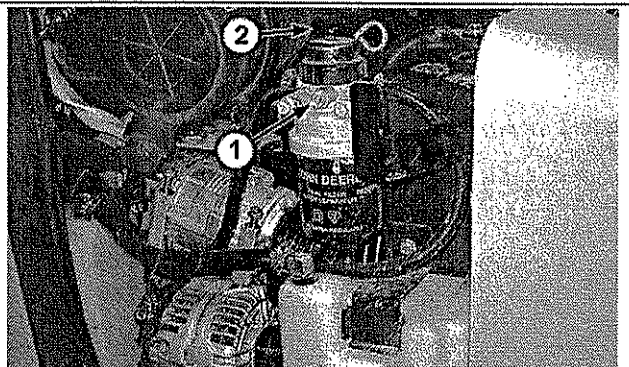

T199498A—UN—26APR04

VD76477,00000A2 -19-13JUL05-1/1

Replace Primary Air Cleaner Element

IMPORTANT: Prevent possible engine damage. Do not clean primary air cleaner element. Replace it when air restriction light is illuminated on instrument panel. To prevent dirt from being sucked into engine, do not remove element when engine is running.

Do not start engine without both the primary and secondary filter elements installed.

1. Park machine.
2. Open rear service door and engine cover, and remove left side panel.
3. Unhook end cap latches (1), and remove end cap.
4. Remove and discard primary element (2).
5. Clean any loose dirt from canister, and inspect end of canister for dirt that may prevent new element from sealing properly.
6. Install new primary element.
7. Install cover, and secure latches.
8. Start engine and check air restriction indicator to be sure there is no restriction.
 - If air restriction indicator still shows restriction, replace secondary element.
9. Install left side panel, and close engine cover and rear service door.

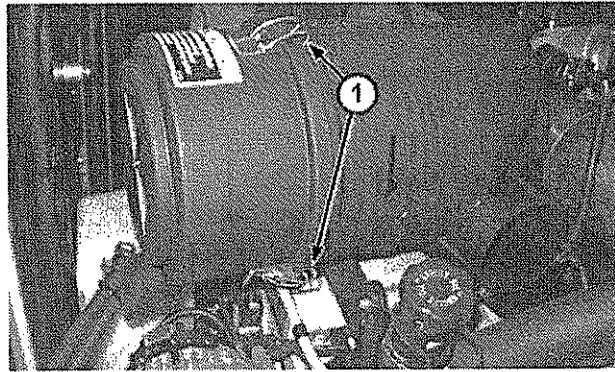

T198984A—UN—06APR04

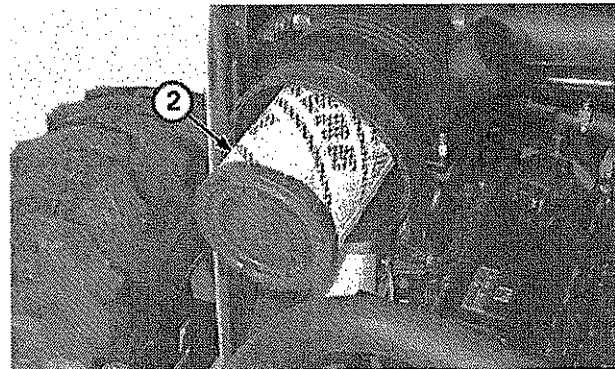

T163737B—UN—25APR02

1—End Cap Latch

2—Primary Element

VD76477,00000A0 -19-21MAR07-1/1

Replace Hydraulic Oil Tank Breather Element

1. Park machine.
2. Raise operator's station.
3. Loosen and slide hose clamps away from breather element (1). Remove hoses.
4. Remove element.
5. Install new element.
6. Install hoses, and tighten clamps.
7. Lower operator's station.

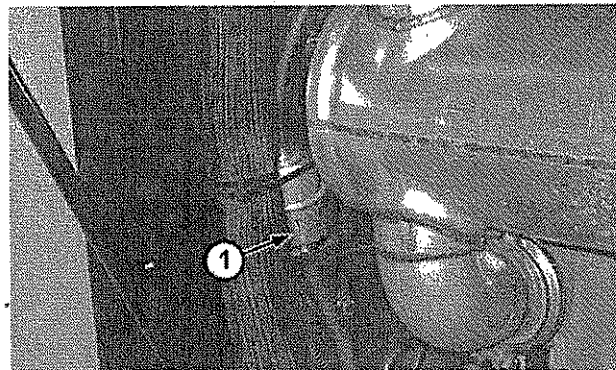

T198985A—UN—06APR04

VD76477,00000A1 -19-21MAR07-1/1

Replace Hydraulic Oil Filter

1. Park machine.
2. Open rear service door and engine cover, and remove right side panel.
3. Turn filter (1) with a filter wrench to remove.
4. Put a film of clean hydraulic oil on seal of new filter.
5. Install filter until it contacts mounting surface. Tighten filter by hand 2/3 to 1 turn more.
6. Install side panel, and close engine cover and rear service door.

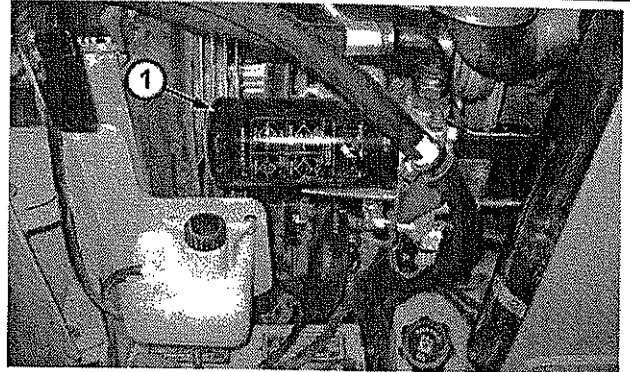

T198986A—JUN—06APR04

1—Hydraulic Oil Filter

TX14740,0000119 -19-14MAR07-1/1

Check Chain Case Oil Level

1. Park machine.
2. Remove fill plugs (2) located on each side of the machine frame. Add oil if necessary. See Maintenance-Machine. (Section 3-1.)
3. Fill each chain case until oil level is at 12.7 mm (0.5 in.) below fill plug threads.

Specification

Chain Case	
Oil—Capacity	7.1 L 1.9 gal (per side)

4. Install fill plugs.

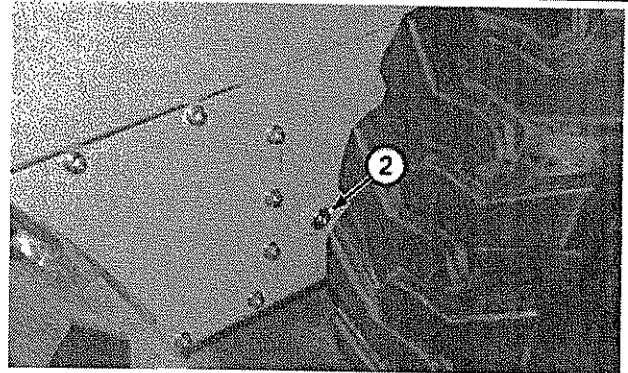

T194689A—JUN—22SEP03

2—Fill Plug

TX14740,0000110 -19-14MAR07-1/1

Check Battery Electrolyte Level and Terminals

CAUTION: Battery gas can explode. Keep sparks and flames away from batteries. Use a flashlight to check battery electrolyte level.

NEVER check battery charge by placing a metal object across the posts. Use a voltmeter or hydrometer.

ALWAYS remove grounded (-) battery clamp first, and replace it last.

Sulfuric acid in battery electrolyte is poisonous. It is strong enough to burn skin, eat holes in clothing, and cause blindness if splashed into eyes.

Avoid the hazard by:

1. Filling batteries in a well-ventilated area.
2. Wearing eye protection and rubber gloves.
3. Avoiding breathing fumes when electrolyte is added.
4. Avoiding spilling or dripping electrolyte.
5. Use proper jump start procedure.

If you spill acid on yourself:

1. Flush contacted skin with water.
2. Apply baking soda or lime to contacted area to help neutralize the acid.
3. Flush eyes with water for 15—30 minutes. Get medical attention immediately.

If acid is swallowed:

1. Do not induce vomiting.

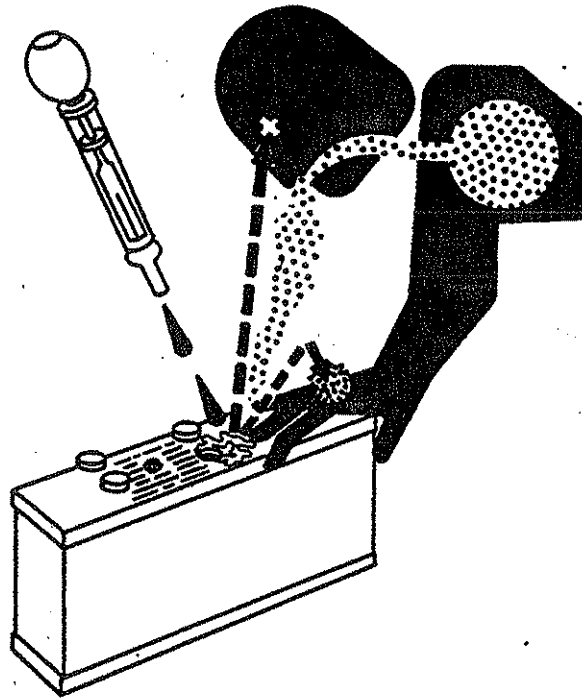

TS203—UN—23AUG88

2. Drink large amounts of water or milk, but do not exceed 1.9 L (2 qt).
3. Get medical attention immediately.

1. Remove battery box cover.

Continued on next page

TX14740,0001CBE -19-14MAR07-1/3

Maintenance—Every 500 Hours

IMPORTANT: If water is added to batteries during freezing weather, batteries must be charged after water is added to prevent batteries from freezing. Charge battery using a battery charger or by running the engine.

2. Fill each cell to within specified range with distilled water. DO NOT overfill.

CAUTION: Prevent possible injury. ALWAYS remove grounded (-) battery clamp first, and replace it last.

3. Disconnect battery clamps, grounded clamp first.

1— Battery Post
2— Fill Tube

3— Electrolyte Level Range

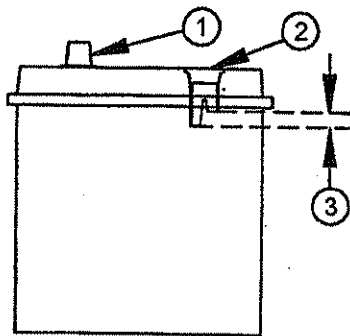
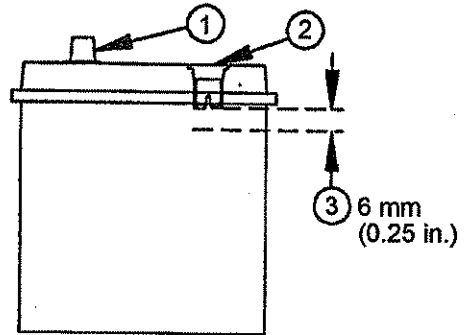

T137535—UN—25JAN01

T137536—UN—25JAN01

TX14740,0001CBE -19-14MAR07-2/3

4. Clean battery terminals (1) and clamps with a stiff brush.
5. Apply lubricating grease (2) around battery terminal base only.
6. Install and tighten clamps, grounded clamp last.

1— Battery Terminal

2— Lubricating Grease

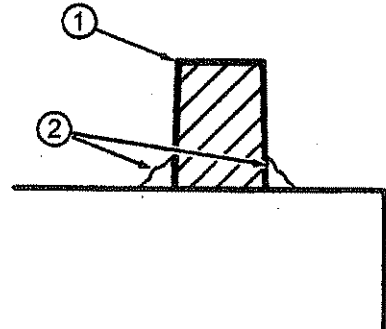

T137537—UN—25JAN01

TX14740,0001CBE -19-14MAR07-3/3

Change Engine Oil and Replace Filter

See Change Engine Oil and Replace Filter. (Section 3-5.)

DW90712,0000122 -19-31JAN07-1/1

Replace Auxiliary Water Separator Fuel Filter—If Equipped

1. Open air vent (7) and remove drain plug (5) to drain fuel into a suitable container. Dispose of fuel waste properly.
2. Disconnect heater connector (4) and water probe (3) if equipped.
3. Remove glass bowl (2).
4. Remove and replace filter element (1).
5. Install glass bowl and drain plug.
6. Fill fuel filter by using air vent and priming hand pump (6).
7. Connect heater connector and water probe if equipped.
8. Start engine and let it run for 1 minute. Check for leaks. Tighten glass bowl only enough to stop leaks.

- | | |
|------------------------------|----------------------|
| 1— Filter Element | 5— Drain Plug |
| 2— Glass Bowl | 6— Priming Hand Pump |
| 3— Water Probe (if equipped) | 7— Air Vent |
| 4— Heater Connector | |

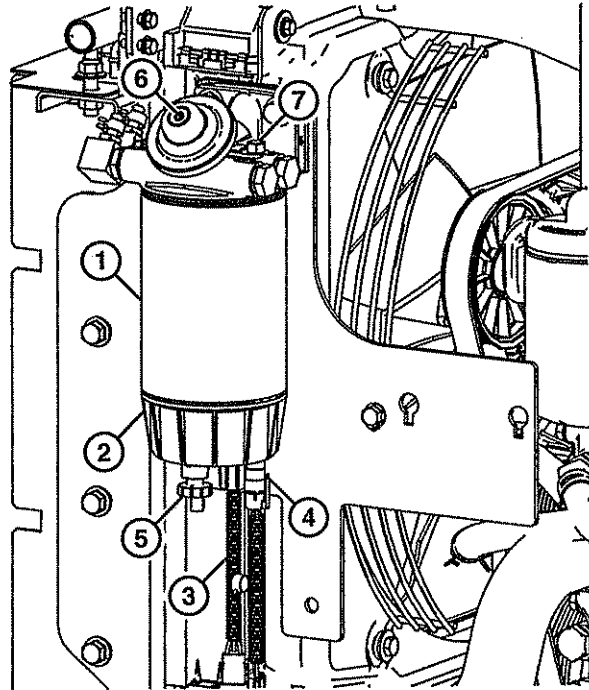

Auxiliary Water Separator Fuel Filter

CP94658,0000176 -19-07JAN09-1/1

TX1053385—UN—19DEC08

Lubricate Steering Linkage

1. Raise operator's station. See Raising Operator's Station. (Section 3-2.)
2. Lubricate universal driveshaft grease fittings (1) and steering arm grease fittings (2) with one or two shots of grease. See Grease. (Section 3-1.)
3. Lower operator's station.

- | | |
|---|---|
| 1— Universal Driveshaft Grease Fitting (2 used) | 2— Steering Arm Grease Fitting (2 used) |
|---|---|

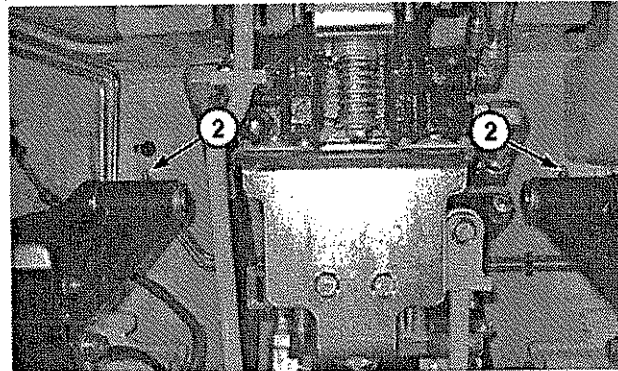
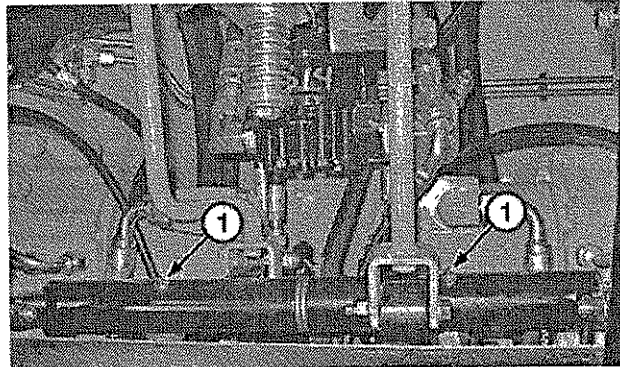

MD04263,0000083 -19-15JAN09-1/1

TX1051673A—UN—20NOV08

TX1051674A—UN—20NOV08

Maintenance—Every 500 Hours

Lubricate Foot Pedal

1. Remove cover plates.
2. Lubricate foot pedals with one or two shots of John Deere grease.

1— Lubrication Fitting (2 used)

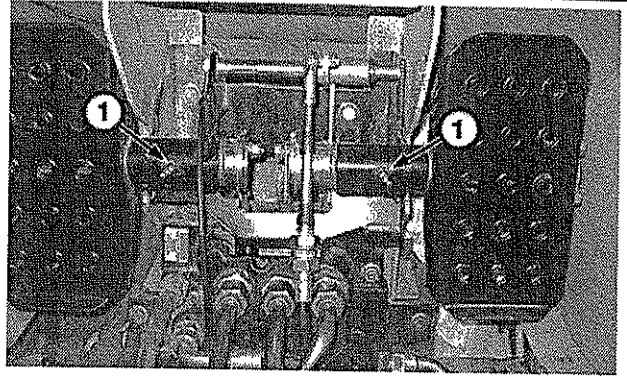

TX1027901A—JN—13AUG07

MD04263,00000B4 -19-15JAN09-1/1

Maintenance—Every 1000 Hours

Replace Secondary Air Cleaner Element

IMPORTANT: Prevent possible machine damage. Do not clean secondary element. Replace it when engine air filter restriction indicator light is lit on the instrument panel and primary element has already been replaced. Do not remove secondary element unless it is being replaced.

Do not start engine without both the primary and secondary filter elements installed.

1. Park machine.
2. Open rear service door and engine cover, and remove left side panel.
3. Unhook three end cap latches, and remove end cap.
4. Remove primary element (1).
5. Remove secondary element (2). Discard element.
6. Install new secondary element.
7. Install primary element.
8. Install end cap, and secure latches.
9. Start engine, and check air restriction light on instrument panel to be sure there is no restriction.

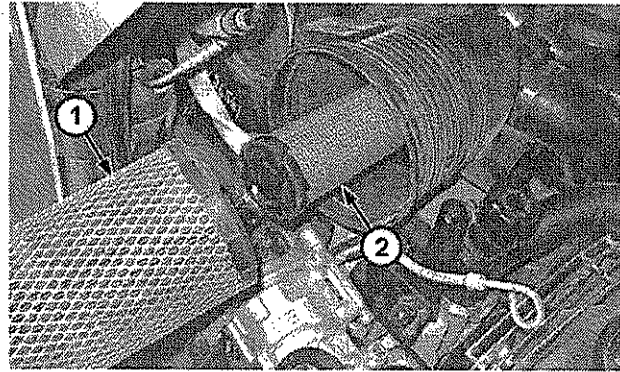

T198987A—UN—06APR04

1—Primary Element

2—Secondary Element

• If restriction indicator light is still on, see your authorized dealer.

10. Install left side panel, and close engine cover and rear service door.

VD76477,000008A -19-14MAR07-1/1

Change Chain Case Oil

1. Park machine.
2. Position a suitable container underneath drain plugs (1) located on bottom rear of each side of machine.
3. Remove drain plug(s).
4. Allow oil to drain into container. Dispose of waste oil properly.
5. Install plugs.
6. Remove fill plugs (2) located on each side of the machine frame.
7. Fill each chain case until oil level is at 12.7 mm (0.5 in.) below fill plug threads. See Maintenance-Machine. (Section 3-1.)

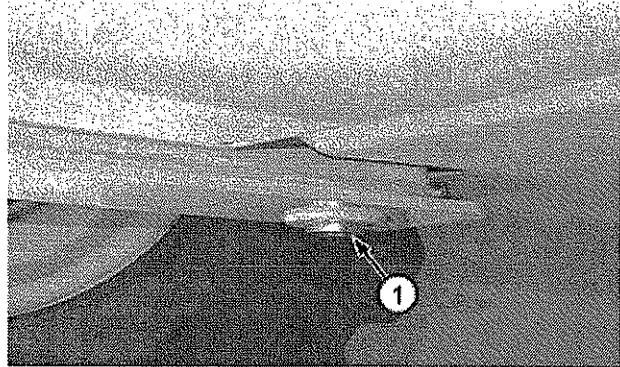

T194683A—UN—22SEP03

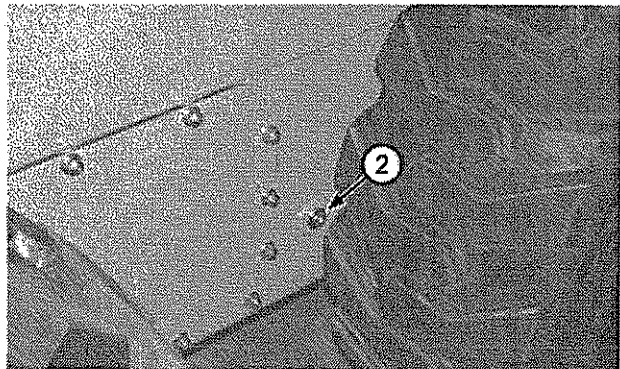

T194684A—UN—22SEP03

Specification

Chain Case
Oil—Capacity 7.1 L
1.9 gal (per side)

8. Install plugs.

1—Drain Plug

2—Fill Plug

TX14740,00000BF -19-14MAR07-1/1

Change Hydraulic Tank Oil

1. Park machine.
2. Open rear service door and engine cover, and remove right side panel.
3. Remove hydraulic tank filler cap.
4. Position a suitable container under hydraulic drain plug (1).
5. Remove drain plug, and drain oil.
6. Dispose of waste oil properly.
7. Install drain plug.
8. Fill hydraulic oil tank. See Maintenance-Machine. (Section 3-1.)

Specification

Hydraulic Tank
Oil—Capacity..... 19.0 L
5.0 gal

9. Check hydraulic tank oil level.
10. Inspect drain plug for leakage.
11. Install hydraulic tank filler cap.
12. Install side panel, and close engine cover and rear service door.

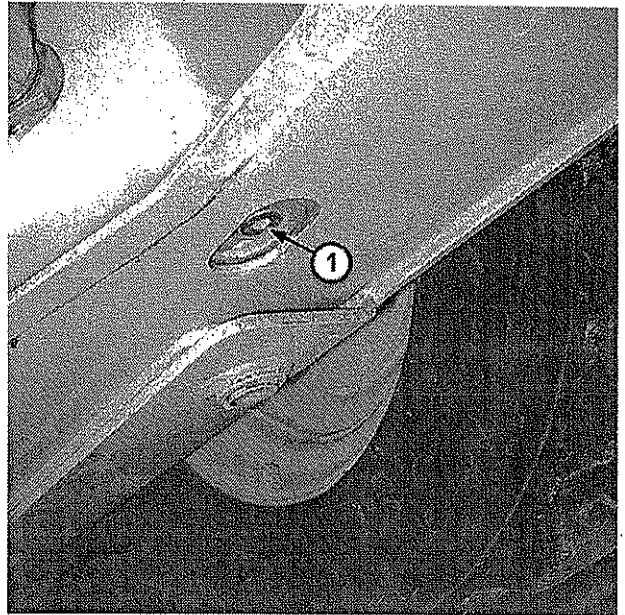

1— Hydraulic Drain Plug

TX1052369A—JUN—02DEC08

MD04263,0000066 -19-02DEC08-1/1

Maintenance—Every 2000 Hours

Drain Cooling System

CAUTION: Explosive release of fluids from pressurized cooling system can cause serious burns:

Shut off engine.

Remove filler cap only when radiator is cool enough to touch with bare hands. Slowly loosen cap to the first stop to relieve pressure before removing completely.

1. Park machine.
2. Allow engine to cool.
3. Open rear service door and engine cover.
4. Slowly remove radiator cap (1).
5. Open drain valve (2), and allow coolant to drain into a suitable container.
6. After coolant has drained, close radiator drain valve.
7. Flush cooling system.

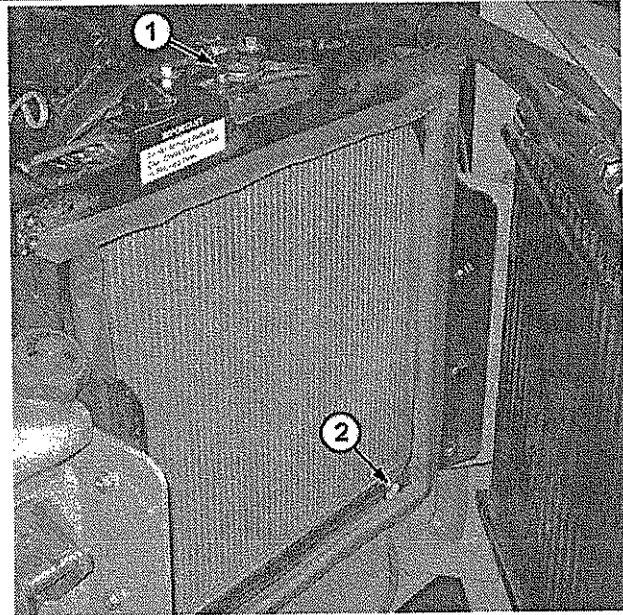

1—Radiator Cap

2—Drain Valve

T199046A—JUN—06APR04

TX14740,00000C2 -19-14MAR07-1/1

Flush Cooling System

IMPORTANT: To prevent engine damage:

- Do not pour water into a hot engine.
- Do not operate engine without coolant.

1. Fill cooling system with clean water and John Deere Cooling System Cleaner, John Deere Cooling System Quick Flush. Follow directions on the can.
2. Install and tighten radiator cap.
3. Start engine, and run engine until it reaches operating temperature.

CAUTION: Engine and coolant will be hot. Avoid contact with skin to prevent serious burns.

4. Stop engine.
5. Drain cooling system immediately before rust and dirt settle.
6. Remove recovery tank (1) and overflow hose.
7. Clean tank.
8. Install tank and overflow hose.
9. Fill cooling system slowly.

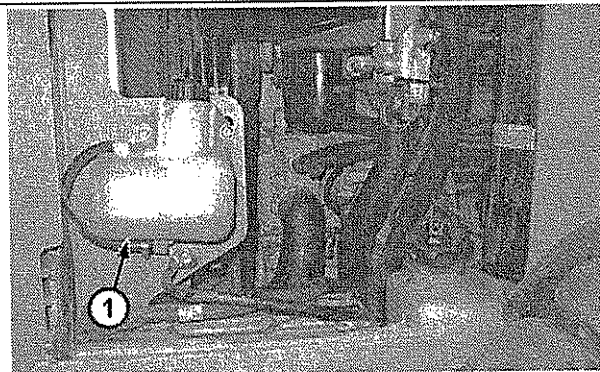

T199047A—JUN—06APR04

TX14740,00000C1 -19-14MAR07-1/1

Fill Cooling System

IMPORTANT: Prevent possible machine damage. Using incorrect coolant mixture can damage radiator:

- Do not operate engine without coolant.
- Do not operate engine with plain water.
- Use antifreeze approved for use in aluminum engines.
- Do not exceed a 50% antifreeze mixture for coolant.
- Do not pour coolant or water into radiator when engine is hot.

NOTE: John Deere COOL-GARD™ coolant is recommended when adding new coolant to cooling system.

Follow directions on container for correct mixture ratio.

1. Open rear service door.

COOL-GARD is a trademark of Deere & Company

2. Check condition of coolant system hoses. If new hoses are needed, see your authorized dealer.
3. Fill cooling system slowly.

Specification

Cooling System—Refill	
Capacity.....	6.6 L
	7.0 qt.

4. Install and tighten radiator cap.
5. Start engine and run until engine reaches operating temperature, allowing entire system to be filled with coolant.
6. Stop engine.
7. Allow engine to cool.
8. Refill recovery tank if necessary.

TX14740,00000ED -19-14MAR07-1/1

Miscellaneous—Machine

Checking Radiator, Air Conditioning Condenser

Clean radiator and cooler fins.

Check radiator, A/C condenser—if equipped, and coolers for dirt, damage, leaks, and loose or broken mounting.

TX17994,00002BB -19-22MAR07-1/1

Replacing Fan and Alternator Belt

1. Inspect belts for cracks, fraying, or stretched out areas. Replace if necessary.
2. To replace belt, release tension on belt.
3. Remove belt from pulleys, and discard belt.
4. Install new belt, making sure belt is correctly seated in all pulley grooves.
5. Start engine, and check belt alignment.

1—Crankshaft Pulley

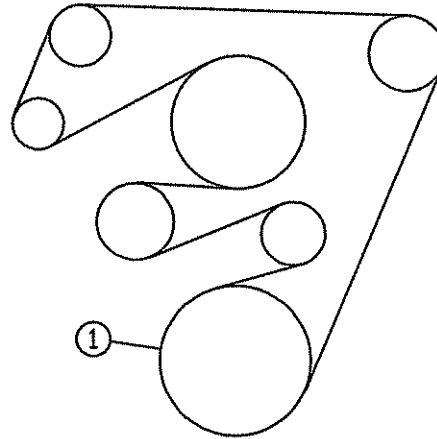

With Air Conditioner

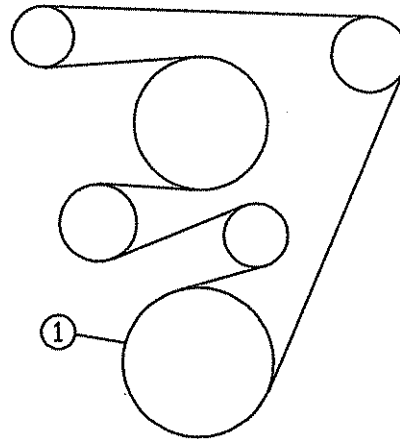

Without Air Conditioner

TX14740,0000135 -19-14MAR07-1/1

T199066—JUN—07APR04

T199066—JUN—07APR04

Adjusting Auxiliary Hydraulic Linkage—Hand-Foot Machines

The auxiliary hydraulic linkage goes down through the right control lever to the control valve.

1. Park machine.
2. Lock boom in raised position.
3. Remove center cover plate.
4. Rotate handle all the way up and all the way down. Ensure that the valve locks into detent.
5. Confirm that when handle is returned to the neutral position, the locking mechanism (1) will engage without movement of the handle.
6. If necessary, adjust position of cable forward or backward using nuts (2) to properly position handle.
7. Install center cover plate, and lower boom to ground.

1— Locking Mechanism

2— Nuts

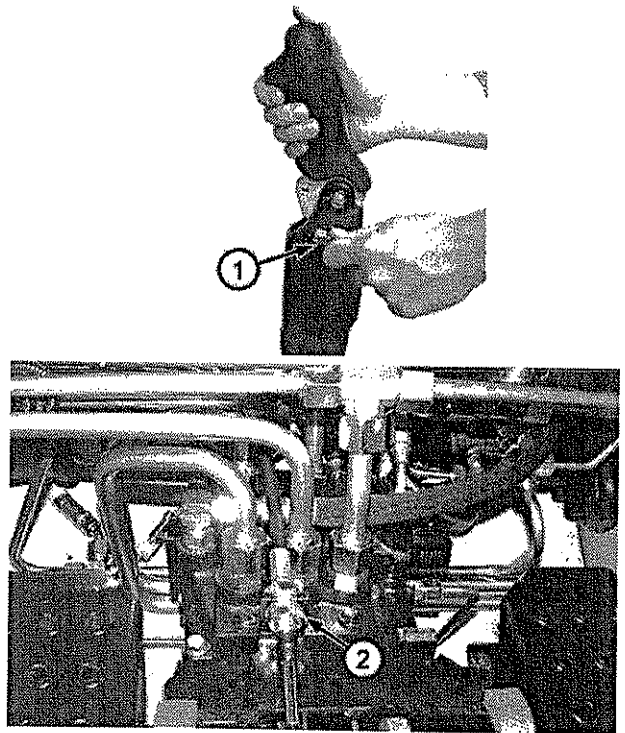

T194727A—UN—22SEP03

T154338B—UN—13MAY02

TX14740,0000113 -19-10APR07-1/1

Adjusting Boom and Bucket Linkage—Hands Only Machine

1. Park machine.
2. Lock boom in raised position.
3. Remove center cover plate.
4. Pivot each handle left and right. Ensure that boom control valve locks into detent.
5. Confirm that when handles are returned to neutral position, they are in the center of opening range.
6. If necessary, adjust positions of cables forward or backward using nuts (1) to properly position handles.
7. Install center cover plate, and lower boom to ground.

1— Nuts

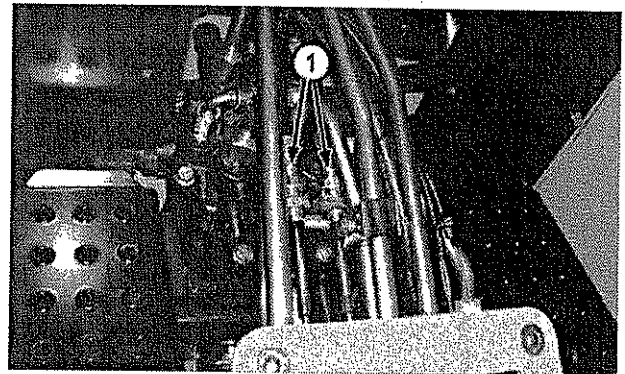

T154544B—UN—08AUG02

HG31779,0000070 -19-14MAR07-1/1

Adjusting Pedal Angle

The angle of the pedals can be adjusted to suit different operators or different footwear which affects foot position.

1. Loosen bolt (1), and move pedal to the desired angle.
2. Tighten bolt.

1— Bolt

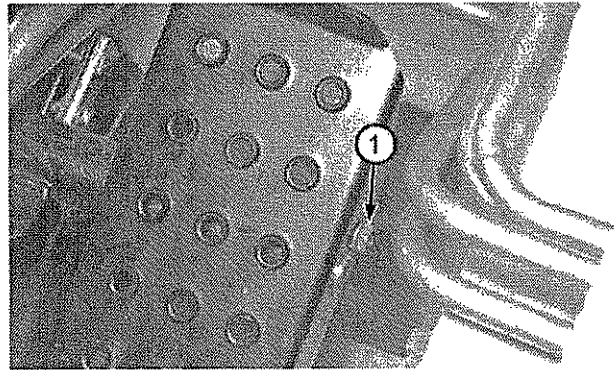

T194730A—UN—22SEP03

TX14740,00000C4 -19-14MAR07-1/1

Cleaning and Replacing Air Conditioner and Heater/Defroster Air Filters (If Equipped)

NOTE: Check pre cleaning foam (2) and air filter element (3) periodically, especially if running in dirty applications.

1. Park machine.
2. Remove cap screws, and remove shield (1).
3. Remove pre cleaning foam and air filter element.
4. The filter element can be blown off with a low pressure air gun and reused or replaced.
5. Reuse or replace pre cleaning foam and filter element.
6. Install the element with the rubber seal toward the heater core.
7. Install shield and cap screws.

1— Shield

3— Air Filter Element

2— Pre Cleaning Foam

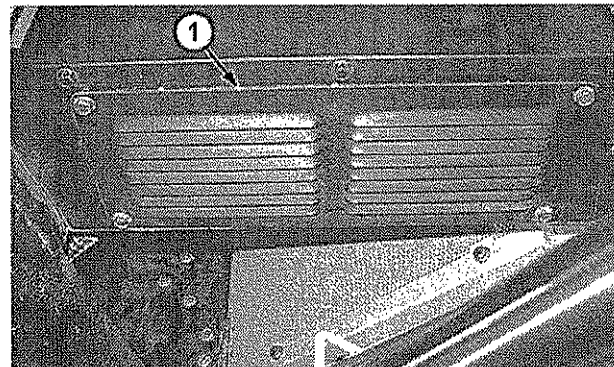

T199320A—UN—16APR04

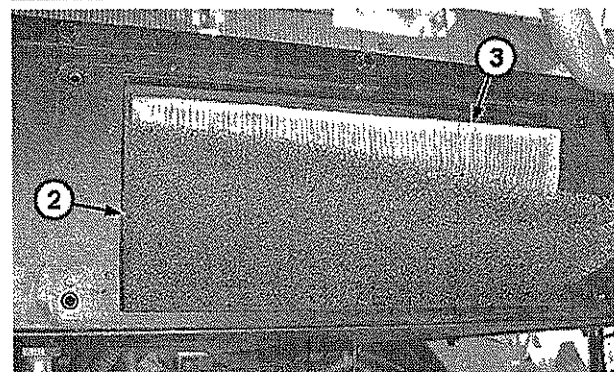

T199321A—UN—16APR04

TX14740,0000133 -19-14MAR07-1/1

Checking Battery Electrolyte Level (Maintenance Type Batteries Only)

A maintenance-free battery is standard on machine. If a non-maintenance free battery has been installed, the following caution applies:

⚠ CAUTION: Sulfuric acid in battery electrolyte is poisonous. It is strong enough to burn skin, eat holes in clothing, and cause blindness if splashed into eyes.

Wear eye protection, and avoid spilling or dripping electrolyte.

Flush eyes with water for 15-30 minutes if acid is splashed into eyes. Get medical attention immediately.

If acid is swallowed, get medical attention immediately.

1. Park machine.
2. Open rear service door and engine cover.
3. Remove left side engine panel.
4. Clean battery with a damp cloth or rag. Keep dirt out of battery cells.
5. Remove battery caps.

IMPORTANT: DO NOT fill cells to the bottom of filler neck (1). Electrolyte can overflow when battery is charged and cause damage.

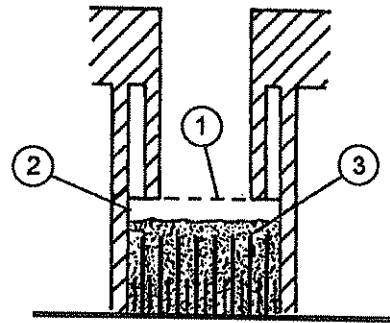

1— Filler Neck
2— Electrolyte

3— Plates

6. Electrolyte (2) should be 6 mm (1/4 in.) above plates (3).
7. Add distilled water, if necessary, to battery cells.
8. Install battery caps.
9. Install left side panel, close engine cover and rear service door.

T195051—UN—22SEP03

TX14740,00000D4 -19-31JAN07-1/1

Using Battery Charger

CAUTION: Prevent possible injury from exploding battery. Do not charge a battery if the battery is frozen or it may explode. Warm battery to 16°C (60°F) before charging.

Turn off charger before connecting or disconnecting it.

IMPORTANT: Do not use battery charger as a booster if a battery has a 1.150 specific gravity reading or lower.

Disconnect battery ground (—) clamp before charging batteries in the machine to prevent damaging electrical components.

A battery charger may be used as a booster to start engine.

Ventilate the area where batteries are being charged.

Stop or cut back charging rate if battery case feels hot, or is venting electrolyte. Battery temperature must not exceed 52°C (125°F).

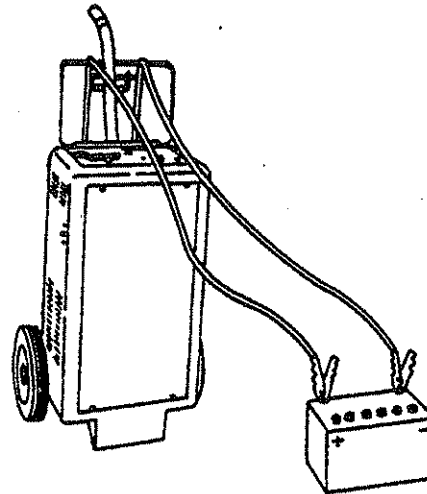
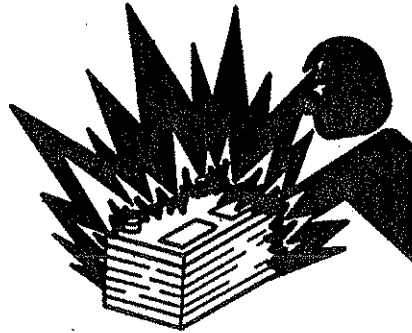

TS204—UN—23AUG88

N36890—UN—07OCT88

DW90712,00004AB -19-31JAN07-1/1

Cleaning or Replacing Battery

⚠ CAUTION: Battery gas can explode:

Keep sparks and flames away from batteries. Use a flashlight to check battery electrolyte level.

Never check battery charge by placing a metal object across the posts.

Always remove grounded (-) battery clamp first, and replace it last.

NOTE: It is not necessary to raise boom arms onto boom lock to remove the battery. However, doing so will improve accessibility to the battery.

1. Remove any attachment.
2. Park machine.
3. Lock boom in the raised position.
4. Stop engine, and engage park brake.
5. Open rear service door and engine cover.
6. Remove left side panel.
7. Disconnect black negative (-) cable (1) from battery.
8. Pull back red positive terminal cover, and disconnect red positive (+) cable (2).
9. Clean battery with a damp cloth or rag. Keep dirt out of battery cells.

⚠ CAUTION: DO NOT allow battery hold down to come in contact with the (-) negative and (+) positive terminals.

10. If necessary, remove battery to thoroughly clean it:
 - Remove coolant recovery tank.
 - Loosen J-bolt on battery hold down bracket.
 - Lift battery from battery compartment.
11. Clean battery, battery terminals, cable ends, battery box, and other parts with a solution of 1 part baking soda to 4 parts water. Keep solution out of battery cells.

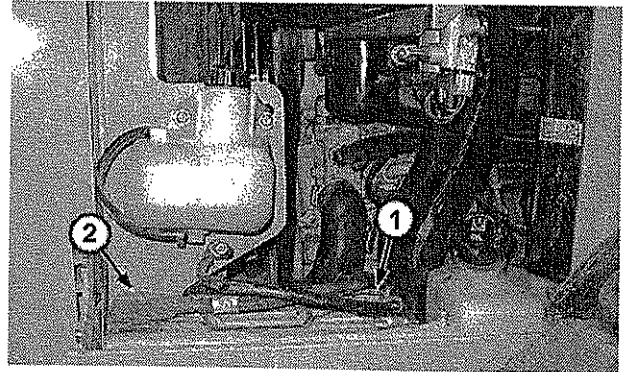

1— Negative (-) Cable

2— Positive (+) Cable

12. Rinse all parts with clean water and let dry.

NOTE: If a new battery is needed, install a John Deere battery or a battery of equal specification. See your authorized dealer.

13. Install battery:

- Place battery in battery compartment.
- Install battery hold down bracket by inserting in rear frame slot.
- Install J-bolt, and tighten hardware.
- Install coolant recovery tank.

14. Connect red positive (+) cable to battery positive (+) terminal. Apply petroleum or silicone spray to terminal to prevent corrosion. Make sure connection is tight. Push red positive cover over positive terminal.
15. Connect black negative (-) cable to battery. Apply petroleum jelly or silicone spray to prevent corrosion. Make sure connection is tight.
16. Install side panel, and close engine cover and rear service door.

TX14740,0000136 -19-20APR04-1/1

T199368A—UN—21APR04

Using Booster Batteries—24-Volt System

Before boost starting, machine must be properly shut down to prevent unexpected machine movement when engine starts.

CAUTION: An explosive gas is produced while batteries are in use or being charged. Keep flames or sparks away from the battery area. Make sure the batteries are charged in a well ventilated area.

IMPORTANT: The machine electrical system is a 24-volt negative (-) ground. Connect two 12-volt booster batteries together as shown for 24-volts.

1. Connect one end of the positive cable to the positive terminal of the machine batteries (A) and the other end to the positive terminal of the booster batteries (B).
2. Connect one end of the negative cable to the negative terminal of the booster batteries. Connect the other end of the negative cable to the machine frame as far away from the machine batteries as possible.
3. Start engine.
4. Immediately after starting engine disconnect the end of the negative cable from the machine frame. Then

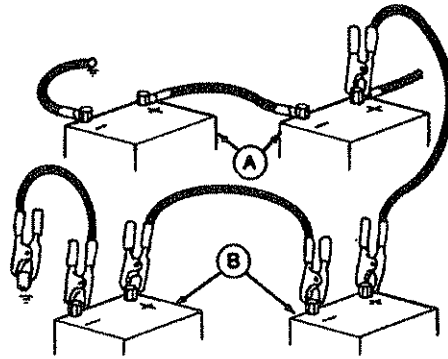

A—Machine Batteries

B—Booster Batteries

5. Disconnect positive cable from booster batteries and machine batteries.
- disconnect the other end of the negative cable from the negative terminal of the booster batteries.

OUT4001,0000238 -19-05NOV08-1/1

Replacing Fuses

1. Locate fuse panel cover (1) in operator's station on right side.
2. Remove fuse panel cover.
3. Pull fuse out of socket.
4. Check metal clip in fuse window. Discard fuse if clip is broken.
5. Push new fuse into proper socket. Be sure new fuse is the same amperage as removed fuse.

1— Fuse Panel Cover

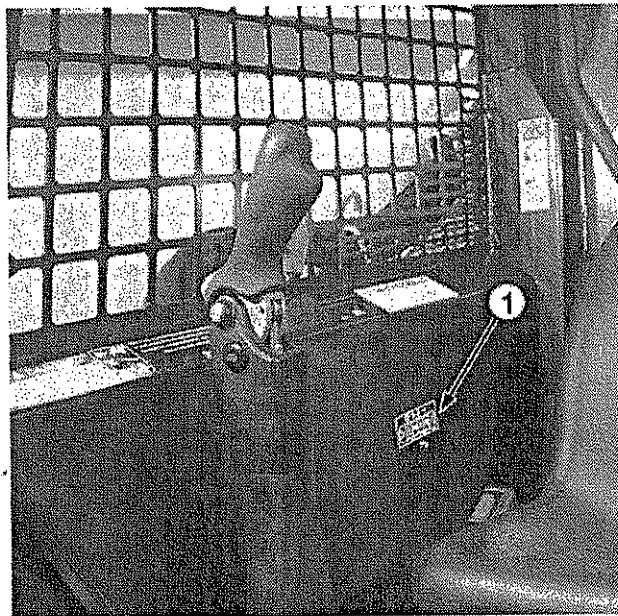

T154183B —UN—22APR02

Continued on next page

TX14740,00000C9 -19-29JUN05-1/2

Miscellaneous—Machine

1—F1—Key Switch and
Accessory 15 Amp Fuse
2—F2—Monitor 15 Amp Fuse

3—F3—Accessory 25 Amp
Fuse
4—F4—Lights 20 Amp Fuse

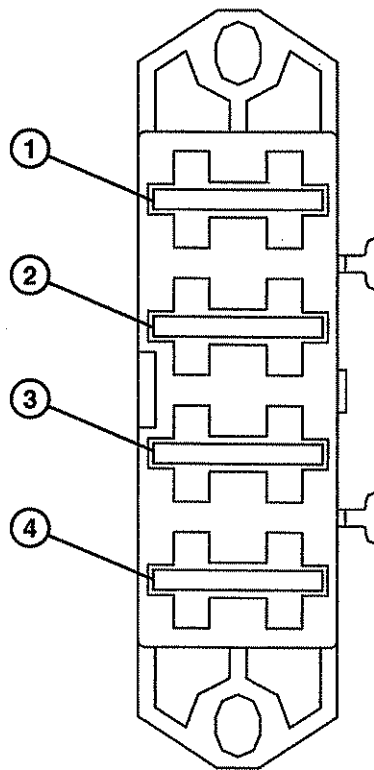

T198240—JUN—08MAR04

TX14740,00000C9 -19-29JUN05-2/2

Replacing Blower Motor Fuse

1. Park machine.
2. Raise operator's station, and ensure operator's station is safely in the locked position.
3. Locate 15 amp blower motor fuse (1), located by the blower motor under the air conditioner and heater box (2) cover.
4. Pull fuse from socket.
5. Check metal clip in fuse window. Discard fuse if clip is broken.
6. Push new 15 amp fuse into socket. Be sure new fuse is the same amperage as removed fuse.

1—Blower Motor Fuse

2—Air Conditioner and Heater
Box

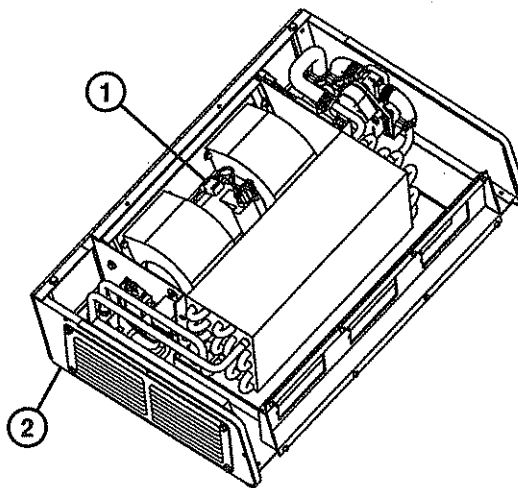

T198393—JUN—09MAR04

TX14740,00000C7 -19-14MAR07-1/1

Replacing Glow Plug Fuse

1. Park machine.
2. Raise operator's station.
3. Locate 80 amp glow plug fuse (1), located underneath the cab on the engine in the engine harness.
4. Pull fuse from socket.
5. Check metal clip in fuse window. Discard fuse if clip is broken.
6. Push new 80 amp fuse into socket. Be sure new fuse is the same amperage as removed fuse.

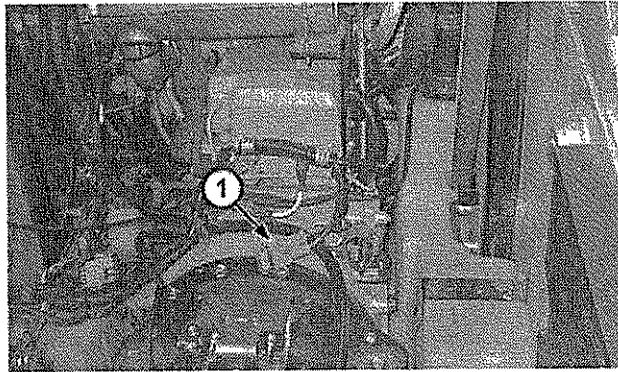

T199057A—JUN—06APR04

1—Glow Plug Fuse

TX14740,00000C8 -19-07JUL05-1/1

Unified Inch Bolt and Cap Screw Torque Values

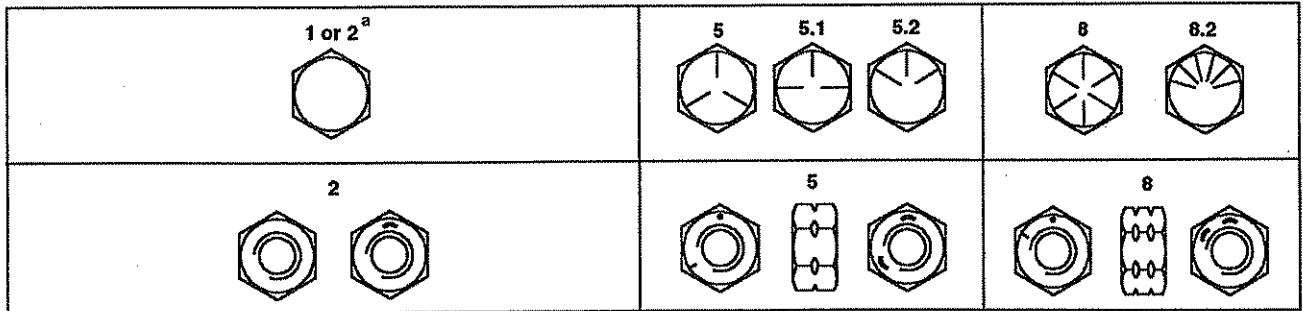

Top, SAE Grade and Head Markings; Bottom, SAE Grade and Nut Markings

Size	Grade 1 (No Mark)		Grade 2 ^a (No Mark)		Grade 5, 5.1 or 5.2		Grade 8 or 8.2	
	Lubricated ^b N-m (lb-ft)	Dry ^c N-m (lb-ft)	Lubricated ^b N-m (lb-ft)	Dry ^c N-m (lb-ft)	Lubricated ^b N-m (lb-ft)	Dry ^c N-m (lb-ft)	Lubricated ^b N-m (lb-ft)	Dry ^c N-m (lb-ft)
1/4	3.8 (2.8)	4.7 (3.5)	6 (4.4)	7.5 (5.5)	9.5 (7)	12 (9)	13.5 (10)	17 (12.5)
5/16	7.7 (5.7)	9.8 (7.2)	12 (9)	15.5 (11.5)	19.5 (14.5)	25 (18.5)	28 (20.5)	35 (26)
3/8	13.5 (10)	17.5 (13)	22 (16)	27.5 (20)	35 (26)	44 (32.5)	49 (36)	63 (46)
7/16	22 (16)	28 (20.5)	35 (26)	44 (32.5)	56 (41)	70 (52)	80 (59)	100 (74)
1/2	34 (25)	42 (31)	53 (39)	67 (49)	85 (63)	110 (80)	120 (88)	155 (115)
9/16	48 (35.5)	60 (45)	76 (56)	95 (70)	125 (92)	155 (115)	175 (130)	220 (165)
5/8	67 (49)	85 (63)	105 (77)	135 (100)	170 (125)	215 (160)	240 (175)	305 (225)
3/4	120 (88)	150 (110)	190 (140)	240 (175)	300 (220)	380 (280)	425 (315)	540 (400)
7/8	190 (140)	240 (175)	190 (140)	240 (175)	490 (360)	615 (455)	690 (510)	870 (640)
1	285 (210)	360 (265)	285 (210)	360 (265)	730 (540)	920 (680)	1030 (760)	1300 (960)
1-1/8	400 (300)	510 (375)	400 (300)	510 (375)	910 (670)	1150 (850)	1450 (1075)	1850 (1350)
1-1/4	570 (420)	725 (535)	570 (420)	725 (535)	1280 (945)	1630 (1200)	2050 (1500)	2600 (1920)
1-3/8	750 (550)	950 (700)	750 (550)	950 (700)	1700 (1250)	2140 (1580)	2700 (2000)	3400 (2500)
1-1/2	990 (730)	1250 (930)	990 (730)	1250 (930)	2250 (1650)	2850 (2100)	3600 (2650)	4550 (3350)

^a Grade 2 applies for hex cap screws (not hex bolts) up to 6 in. (152 mm) long. Grade 1 applies for hex cap screws over 6 in. (152 mm) long, and for all other types of bolts and screws of any length.

^b "Lubricated" means coated with a lubricant such as engine oil, or fasteners with phosphate and oil coatings.

^c "Dry" means plain or zinc plated without any lubrication.

DO NOT use these values if a different torque value or tightening procedure is given for a specific application. Torque values listed are for general use only. Check tightness of fasteners periodically.

Make sure fastener threads are clean and that you properly start thread engagement. This will prevent them from failing when tightening.

Shear bolts are designed to fail under predetermined loads. Always replace shear bolts with identical grade.

Tighten plastic insert or crimped steel-type lock nuts to approximately 50 percent of the dry torque shown in the chart, applied to the nut, not to the bolt head. Tighten toothed or serrated-type lock nuts to the full torque value.

Fasteners should be replaced with the same or higher grade. If higher grade fasteners are used, these should only be tightened to the strength of the original.

TX17994,00002D3 -19-11MAR02-1/1

Metric Bolt and Cap Screw Torque Values

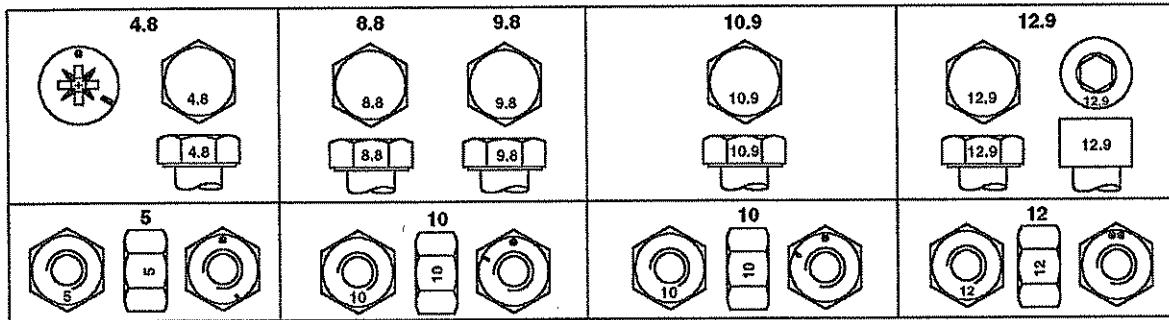

Top, Property Class and Head Markings; Bottom, Property Class and Nut Markings

TORQ2—UN—07SEP99

Size	Class 4.8		Class 8.8 or 9.8		Class 10.9		Class 12.9	
	Lubricated ^a N·m (lb-ft)	Dry ^b N·m (lb-ft)	Lubricated ^a N·m (lb-ft)	Dry ^b N·m (lb-ft)	Lubricated ^a N·m (lb-ft)	Dry ^b N·m (lb-ft)	Lubricated ^a N·m (lb-ft)	Dry ^b N·m (lb-ft)
M6	4.7 (3.5)	6 (4.4)	9 (6.6)	11.5 (8.5)	13 (9.5)	16.5 (12.2)	15.5 (11.5)	19.5 (14.5)
M8	11.5 (8.5)	14.5 (10.7)	22 (16)	28 (20.5)	32 (23.5)	40 (29.5)	37 (27.5)	47 (35)
M10	23 (17)	29 (21)	43 (32)	55 (40)	63 (46)	80 (59)	75 (55)	95 (70)
M12	40 (29.5)	50 (37)	75 (55)	95 (70)	110 (80)	140 (105)	130 (95)	165 (120)
M14	63 (46)	80 (59)	120 (88)	150 (110)	175 (130)	220 (165)	205 (150)	260 (190)
M16	100 (74)	125 (92)	190 (140)	240 (175)	275 (200)	350 (255)	320 (235)	400 (300)
M18	135 (100)	170 (125)	265 (195)	330 (245)	375 (275)	475 (350)	440 (325)	560 (410)
M20	190 (140)	245 (180)	375 (275)	475 (350)	530 (390)	675 (500)	625 (460)	790 (580)
M22	265 (195)	330 (245)	510 (375)	650 (480)	725 (535)	920 (680)	850 (625)	1080 (800)
M24	330 (245)	425 (315)	650 (480)	820 (600)	920 (680)	1150 (850)	1080 (800)	1350 (1000)
M27	490 (360)	625 (460)	950 (700)	1200 (885)	1350 (1000)	1700 (1250)	1580 (1160)	2000 (1475)
M30	660 (490)	850 (625)	1290 (950)	1630 (1200)	1850 (1350)	2300 (1700)	2140 (1580)	2700 (2000)
M33	900 (665)	1150 (850)	1750 (1300)	2200 (1625)	2500 (1850)	3150 (2325)	2900 (2150)	3700 (2730)
M36	1150 (850)	1450 (1075)	2250 (1650)	2850 (2100)	3200 (2350)	4050 (3000)	3750 (2770)	4750 (3500)

^a "Lubricated" means coated with a lubricant such as engine oil, or fasteners with phosphate and oil coatings.

^b "Dry" means plain or zinc plated without any lubrication.

DO NOT use these values if a different torque value or tightening procedure is given for a specific application. Torque values listed are for general use only. Check tightness of fasteners periodically.

Make sure fastener threads are clean and that you properly start thread engagement. This will prevent them from failing when tightening.

Shear bolts are designed to fail under predetermined loads. Always replace shear bolts with identical property class.

Tighten plastic insert or crimped steel-type lock nuts to approximately 50 percent of the dry torque shown in the chart, applied to the nut, not to the bolt head. Tighten toothed or serrated-type lock nuts to the full torque value.

Fasteners should be replaced with the same or higher property class. If higher property class fasteners are used, these should only be tightened to the strength of the original.

TX17994,00002D4 -19-31JAN07-1/1

Miscellaneous—Operational Checkout

Operational Checkout

Use this procedure to check all systems and functions on the machine. It is designed so the operator can make a quick check of machine operation while doing a walk around inspection and performing specific checks from the operator's seat.

Should a problem occur with the machine, helpful diagnostic information can be found in this checkout that will pinpoint the cause. This information may allow operator to perform simple adjustments, reducing machine down time. Use the table of contents to help find adjustment procedures.

The information obtained after completing the operational checkout will allow operator or authorized dealer to pinpoint a specific test or repair needed to restore the machine to design specifications.

A location will be required which is level and has adequate space to complete the checks. No tools or equipment are needed to perform the checkout.

Complete the necessary visual checks (oil levels, oil condition, external leaks, loose hardware, linkage, wiring, etc.) prior to doing the checkout. The machine must be at operating temperature for many of the checks.

Before starting this operational checkout, check diagnostic service codes in monitor. These service codes must be corrected or cleared before starting this checkout.

Start at the top of the left column and read completely down column before performing check. Follow this sequence from left to right. In the far right column, if no problem is found, operator will be instructed to go to next check. If a problem is indicated, operator will be referred to either a section in this manual or to an authorized dealer for repair.

CP94658,000017A -19-18DEC08-1/22

Key Switch OFF, Engine OFF Checks

CP94658,000017A -19-18DEC08-2/22

Diagnostic Trouble Code Check

Always check for diagnostic trouble codes, and correct them before performing the operational checkout.

Diagnostic trouble codes are displayed on the Engagement Monitor Unit.

Sit in seat and access diagnostic trouble code menu.

LOOK: Are diagnostic trouble codes present?

YES: Correct all diagnostic trouble codes.

NO: Proceed with operational checkout.

CP94658,000017A -19-18DEC08-3/22

Monitor and Gauge Circuits Check

Sit in operator's seat.

LOOK: Do gauges move to far right position, then move to the center position, and then display the machine status?

LOOK: Do all indicators illuminate and then go out depending on machine status?

LOOK: Do all monitor display segments turn on, turn off, display correct machine model for 3 seconds, display hour meter for 10 seconds, and then display last selected run display item?

Close cab door if equipped.

LOOK: Does cab door indicator go off?

Buckle seat belt.

LOOK: Do seat and seat belt indicators go off?

YES: Go to next check.

NO: Check F2 Monitor 15 Amp Fuse.

NO: Check Seat, Seat Belt, or Cab Door Switch.

NO: Go to your authorized dealer.

CP94658,000017A -19-18DEC08-4/22

Key Switch ON, Engine OFF Checks

Continued on next page

CP94658,000017A -19-18DEC08-5/22

Miscellaneous—Operational Checkout

Monitor and Gauge Circuits Check	<p>Turn key switch ON.</p> <p><i>LOOK: Do switches on instrument panel illuminate?</i></p> <p><i>LISTEN: Does engagement and monitor unit alarm sound?</i></p>	<p>YES: Go to next check.</p> <p>NO: Check F1 Key Switch and Unswitched Accessory 15 Amp Fuse.</p> <p>Check F3 Accessory 25 Amp Fuse.</p> <p>Check K4 Accessory Relay.</p> <p>NO: Go to your authorized dealer.</p>
---	--	--

CP94658,000017A -19-18DEC08-6/22

Horn Circuit Check	<p>Press horn switch on right steering lever.</p> <p><i>LISTEN: Does horn sound?</i></p>	<p>YES: Go to next check.</p> <p>NO: Check F1 Key Switch and Unswitched Accessory 15 Amp Fuse.</p> <p>Check F3 Accessory 25 Amp Fuse.</p> <p>Check K4 Accessory Relay.</p> <p>NO: Go to your authorized dealer.</p>
---------------------------	--	--

CP94658,000017A -19-18DEC08-7/22

Lights Circuit Check	<p>Push light switch to middle position.</p> <p><i>LOOK: Do front work lights and tail lights turn on?</i></p> <p>Push light switch to upper position.</p> <p><i>LOOK: Do front work lights and tail lights stay on and rear work light turn on?</i></p> <p>If equipped, push dual flasher switch to the upper position.</p> <p><i>LOOK: Do the dual flashers turn on?</i></p>	<p>YES: Go to next check.</p> <p>NO: Check F4 Lights 20 Amp Fuse.</p> <p>NO: Check F1 Key Switch and Unswitched Accessory 15 Amp Fuse.</p> <p>Check F3 Accessory 25 Amp Fuse.</p> <p>Check K4 Accessory Relay.</p> <p>NO: Go to your authorized dealer.</p>
-----------------------------	--	---

CP94658,000017A -19-18DEC08-8/22

Beacon Light Check—If Equipped	<p>Key switch on, engine off.</p> <p><i>LOOK: Does beacon light operate with key switch on?</i></p>	<p>YES: Check complete.</p> <p>NO: See your beacon light circuit.</p>
---------------------------------------	---	---

CP94658,000017A -19-18DEC08-9/22

License Plate Lamp—If Equipped	<p>Key switch on, engine off.</p> <p>Switched on the work light switch on console.</p> <p><i>LOOK: Does license plate lamp operate with key switch on?</i></p>	<p>YES: Check complete.</p> <p>NO: See work light switch circuit.</p>
---------------------------------------	--	---

Continued on next page

CP94658,000017A -19-18DEC08-10/22

Miscellaneous—Operational Checkout

Windshield Wiper Circuit Check (If Equipped)	<p>Close cab door.</p> <p>Push windshield wiper and washer switch to the middle position.</p> <p><i>LOOK: Does wiper operate?</i></p>	<p>YES: Go to next check.</p> <p>NO: Check F1 Key Switch and Unswitched Accessory 15 Amp Fuse.</p> <p>Check F3 Accessory 25 Amp Fuse.</p> <p>Check K4 Accessory Relay.</p> <p>NO: Go to your authorized dealer.</p>
---	---	--

CP94658,000017A -19-18DEC08-11/22

Windshield Washer Circuit Check (If Equipped)	<p>Close cab door.</p> <p>Turn on windshield wiper.</p> <p>Push and hold windshield wiper and washer switch in the upper position.</p> <p>IMPORTANT: Washer motor may be damaged if washer switch is held for more than 20 seconds, or continually operated with no fluid in the washer fluid tank.</p> <p><i>LOOK: Does washer operate?</i></p>	<p>YES: Go to next check.</p> <p>NO: Check washer fluid level.</p> <p>NO: Check washer hose for kinks or obstructions.</p> <p>NO: Check F1 Key Switch and Unswitched Accessory 15 Amp Fuse.</p> <p>Check F3 Accessory 25 Amp Fuse.</p> <p>Check K4 Accessory Relay.</p> <p>NO: Go to your authorized dealer.</p>
--	---	---

CP94658,000017A -19-18DEC08-12/22

Key Switch ON, Engine ON Checks

CP94658,000017A -19-18DEC08-13/22

Engine Start Check	<p>Position engine speed control lever in slow idle position.</p> <p>Start engine.</p> <p><i>LISTEN/LOOK: Does engine speed increase briefly, then return to slow idle?</i></p>	<p>YES: Go to next check.</p> <p>NO: Check slow idle and fast idle engine speeds.</p> <p>Check governor linkage.</p>
---------------------------	---	--

CP94658,000017A -19-18DEC08-14/22



Hydraulic Control Enable Check	<p>Close cab door if equipped.</p> <p>Run engine at slow idle.</p> <p>Engage park brake.</p> <p>Actuate boom and bucket functions.</p> <p><i>LOOK: Do boom and bucket move?</i></p>	<p>NO: Continue check.</p> <p>YES: Check park brake switch.</p>
	<p>Move park brake switch to the run position to enable hydraulics.</p> <p>Actuate boom and bucket functions.</p> <p><i>LOOK: Do boom and bucket move?</i></p>	<p>YES: Go to next check.</p> <p>NO: Check park brake switch.</p> <p>NO: Go to your authorized dealer.</p>

Continued on next page

CP94658,000017A -19-18DEC08-15/22

Miscellaneous—Operational Checkout

<p>Auxiliary Hydraulic Override Check</p>	<p>Close cab door if equipped.</p> <p>Operate auxiliary hydraulic function.</p> <p>Unbuckle seat belt and exit machine.</p> <p><i>LISTEN/LOOK: Does machine shut down?</i></p> <p>Return to seat, fasten seat belt, and close cab door if equipped.</p> <p>Restart machine and operate auxiliary hydraulic function.</p> <p>Press auxiliary hydraulic override switch.</p> <p><i>LOOK: Does "BYPAS" appear in engagement and monitor unit display?</i></p> <p><i>NOTE: Operator must exit machine within 15 seconds of pressing auxiliary hydraulic override switch.</i></p> <p>Open cab door, and exit machine.</p> <p><i>LISTEN/LOOK: Does machine continue to operate after operator has exited the machine?</i></p> <p>Return to seat, fasten seat belt, and close cab door if equipped.</p> <p>Disengage auxiliary hydraulics.</p> <p><i>LOOK: Does engagement and monitor unit exit "BYPAS" mode and return to last run data item?</i></p>	<p>YES: Go to next check.</p> <p>NO: Check auxiliary hydraulic override switch.</p> <p>NO: See your authorized dealer.</p> <p>CP94658,000017A -19-18DEC08-16/22</p>
--	--	--

<p>Park Brake Check</p>	<p>Close cab door if equipped.</p> <p> CAUTION: Prevent injury from unexpected machine movement. Keep bystanders clear of machine.</p> <p>Engage park brake.</p> <p>Gradually move steering levers in the forward direction and then in the reverse direction.</p> <p>IMPORTANT: Extreme movement of steering levers may cause engine to stall while trying to overcome park brake.</p> <p><i>LOOK: Does machine move?</i></p>	<p>NO: Continue check.</p> <p>YES: Check park brake switch.</p> <p>YES: Check park brake. Go to your authorized dealer.</p>
	<p> CAUTION: Prevent injury from unexpected machine movement. Keep bystanders clear of machine.</p> <p>Move park brake switch to release position to disengage park brake.</p> <p>Gradually move steering levers in the forward direction and then in the reverse direction.</p> <p><i>LOOK: Does machine move?</i></p>	<p>YES: Go to next check.</p> <p>NO: Check park brake switch.</p> <p>NO: Check park brake. Go to your authorized dealer.</p> <p>Continued on next page</p> <p>CP94658,000017A -19-18DEC08-17/22</p>

Miscellaneous—Operational Checkout

Hydraulic Quik-Tatch Check (S.N. — 131876)

Close cab door if equipped.

Move park brake switch to the run position to enable hydraulics.

Press and hold lower part of hydraulic Quik-Tatch switch to unlock the Quik-Tatch latches.

LOOK/LISTEN: Do hydraulic Quik-Tatch latches release attachment?

Press and hold the upper part of hydraulic Quik-Tatch switch to lock the Quik-Tatch latches.

LOOK/LISTEN: Do hydraulic Quik-Tatch latches secure attachment?

YES: Go to next check.
NO: Hydraulic Quik-Tatch operates opposite of function indicated on switch. Go to your authorized dealer.
NO: Hydraulic Quik-Tatch does not unlock or lock latches. Go to your authorized dealer.

CP94658,000017A -19-18DEC08-18/22

Electric Quik-Tatch Check (S.N. 131877 —)

Close cab door if equipped.

Press and hold lower part of electric Quik-Tatch switch to unlock the Quik-Tatch latches.

LOOK/LISTEN: Do electric Quik-Tatch latches release attachment?

Press and hold the upper part of electric Quik-Tatch switch to lock the Quik-Tatch latches.

LOOK/LISTEN: Do electric Quik-Tatch latches secure attachment?

YES: Go to next check.
NO: Electric Quik-Tatch operates opposite of function indicated on switch. Go to your authorized dealer.
NO: Electric Quik-Tatch does not unlock or lock latches. Go to your authorized dealer.

CP94658,000017A -19-18DEC08-19/22

Back-Up Alarm Check (If Equipped)



CAUTION: Prevent injury from unexpected machine movement. Keep bystanders clear of machine.

Run engine at slow idle.

Drive machine in reverse.

LOOK/LISTEN: Does back-up alarm sound?

YES: Go to next check.
NO: Check back-up alarm. Go to your authorized dealer.
NO: Check F1 Key Switch and Unswitched Accessory 15 Amp Fuse.
 Check F3 Accessory 25 Amp Fuse.
NO: Go to your authorized dealer.

Continued on next page

CP94658,000017A -19-18DEC08-20/22

Miscellaneous—Operational Checkout

Heating and Air Conditioning System Check

NOTE: Engine will need to be at operating temperature for this check.

Run engine at slow idle.

Turn fan speed switch from off to slow, medium, and high speeds.

LISTEN/FEEL: Does fan speed increase and/or decrease as switch is moved?

Turn fan speed switch to medium speed.

Turn temperature control to hot (red).

FEEL: Does warm air come out of air ducts?

Turn temperature control to cold (blue).

FEEL: Does cool air come out of air ducts?

Turn on air conditioner.

FEEL/LISTEN: Does cold air come out of air duct after a couple of minutes?

YES: Go to next check.
NO: Blower motor does not operate. Check Blower Motor 15 Amp Fuse.
NO: Cab temperature does not change. Check Cab Temperature Control Dial.
NO: Air conditioner does not operate. Check Air Conditioner Switch.
Go to your authorized dealer.

CP94658,000017A -19-18DEC08-21/22

Engine Speed Check

Set the monitor and engagement unit to display engine rpm.

Run engine at slow idle.

LOOK/LISTEN: Does engine run at about 1180—1200 rpm?

Run engine at fast idle.

LOOK/LISTEN: Does engine run at about 2930—2950 rpm?

YES: Go to next check.
NO: Check engine speed.
Go to your authorized dealer.

CP94658,000017A -19-18DEC08-22/22

Miscellaneous—Troubleshooting

Troubleshooting Procedure

NOTE: Troubleshooting charts are arranged from the simplest to verify, to least likely, more difficult to verify. When diagnosing a problem, use all possible means to isolate the problem to a single component or system. Use the following steps to diagnose problems:

Step 1. Operational Checkout Procedure

Step 2. Troubleshooting Charts

Step 3. Adjustments

Step 4. See your authorized dealer

TX14740,00000CB -19-06FEB08-1/1

Engine

Symptom	Problem	Solution
Machine Will Not start	Park brake switch not engaged	Push upper half of switch.
	No power to key switch or park brake switch	Check fuse and battery connection.
	No power to starter	Check key switch, start relay, battery connection, and starter connection.
	Fuel tank empty	Add fuel.
	Improper fuel	Drain fuel tank and add proper fuel.
	Clogged fuel filter	Replace fuel filter.
	Air leak on suction side of fuel system	Check for bubbles in fuel filter and tighten connections. Inspect fuel lines for damage.
	Slow cranking speed	Check battery and connections.
	Restricted air filter	Check air filter restriction indicator and air filter.
	Engine Surges, Stalls, Or Misses	Fuel tank vent clogged
Improper fuel		Drain fuel tank, and add proper fuel.
Restricted air filter		Check air filter restriction indicator and air filter.
Fuel filter clogged		Replace filter.
Engine Overheats	Air intake screens clogged	Clean air intake screens.
	Incorrect coolant mixture	Check coolant mixture.
	Engine oil level low	Check engine oil dipstick.
	Loose or defective fan/alternator belt	Check fan/alternator belt.

TX14740,00000CA -19-14MAR07-1/1

Miscellaneous—Troubleshooting

Electrical System

Symptom	Problem	Solution
Park Brake Will Not Disengage	Seat belt or seat switch is not activated	Fasten seat belt, and activate seat switch. Unfasten and fasten seat belt to reactivate seat switch.
	Park brake has not gone through the momentary down position (unlocked).	Push lower half of switch.
Park Brake Will Not Engage	Park brake is not in the up (locked) position	Push upper half of switch.
Starting Motor Will Not Turn	Battery terminals corroded	Check and clean as necessary.
	Loose connection at starter or starter relay	Check all electrical connections.
	Blown fuse	Replace fuse.
	Battery dead or low charge	Check battery voltage, and charge as necessary.
Engine Cranks Slowly	Low battery input	Check battery voltage, and charge as necessary.
	Loose or corroded battery cables	Inspect and clean or tighten.
	Engine oil viscosity too heavy	Verify engine oil viscosity.
Battery Will Not Charge	Dead cell in battery	Replace battery.
	Low engine speed or excessive idling	Increase engine rpm to raise alternator output.
	Battery cables and terminals dirty	Clean cables and connections as necessary.
	Fan/alternator belt loose or damaged	Check belt. Tighten if loose.
Lights Do Not Work	Blown fuse	Replace fuse.
	Loose or bad bulb	Check bulb connection, or replace as necessary.
Battery Voltage Indicator Light Remains On With Engine Running	Loose or glazed alternator belt	Check belt. Tighten if loose. Replace if glazed.
	Low battery input	Check battery voltage, and charge as necessary.

TX14740,00000CC -19-05APR07-1/1

Miscellaneous—Troubleshooting

Hydraulic System

Symptom	Problem	Solution
Boom And Bucket Will Not Move	Park brake will not engage	Seat belt or seat switch not activated or not properly sequenced.
	Park brake engaged	Disengage park brake.
Excessive Pump Noise	Low oil level	Add oil to correct level.
	Suction line clogged	Check for line restriction, or replace hose as necessary.
	Air leaks at pump inlet line fittings	Check all hydraulic connections, and tighten as necessary.
Low Hydraulic Power	Hydraulic oil aerated	Drain hydraulic oil tank and refill.
	Low oil level	Check oil levels.
	Air leaks at pump inlet line fittings	Check all hydraulic connections, and tighten as necessary.
Slow Hydraulic Function	Auxiliary hydraulic handle locked in detent position (Standard Controls)	Return handle to neutral position.
	Auxiliary hydraulic roller locked in detent position (EH Controls)	Return roller to neutral position.
	Boom or bucket overloaded	Lighten load on hydraulic function.
	Low oil level	Add oil to correct level.
	Engine rpm too low	Increase rpm, or check engine speed.
	Hydraulic oil aerated	Incorrect oil; drain and refill. Suction hose has air leak; inspect and tighten.
	Hose or line leakage	Inspect and tighten fittings.
Machine Loses Power	Dirty or clogged fuel water separator filter	Check fuel water separator filter.

TX14740,00000CD -19-06FEB08-1/1

Miscellaneous—Machine Storage

Prepare Machine for Storage

1. Repair worn or damaged parts. Install new parts if necessary.
2. Clean primary air cleaner.
3. Wash the machine.
4. On track machines, apply waste oil to track chains. Run machine back and forth several times. Park machine on a hard surface to prevent tracks from freezing to ground.
5. On machines with tires, if possible, raise machine high enough so tires do not touch the ground. If not, park on a hard surface to prevent tires from freezing to ground.
6. Store machine in a dry, protected place. If stored outside, cover with a waterproof material.

IMPORTANT: LPS 3 Rust Inhibitor can destroy painted finish. DO NOT spray LPS 3 Rust Inhibitor on painted areas.

7. Retract all hydraulic cylinders, if possible. Coat exposed cylinder rods with LPS ® 3 Rust Inhibitor.

LPS is a trademark of the Holt Lloyd Corporation.

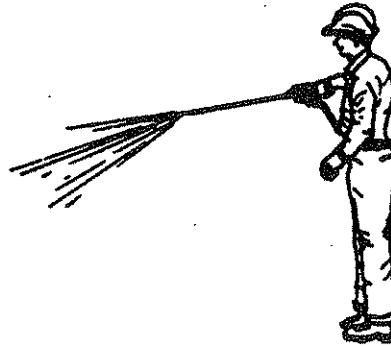

T6813AM—UN—09FEB89

8. Place a "DO NOT OPERATE" tag in an obvious place in the operator's station.
9. Lubricate all grease points.
10. Remove batteries.
11. Remove seat cushion and other perishable items.
12. Remove keys, and lock all covers and doors.

DW90712,00001D6 -19-14MAR07-1/1

Monthly Storage Procedure

CAUTION: Prevent possible injury or death from asphyxiation. Engine exhaust fumes can cause sickness or death. Start engine **ONLY** in a well-ventilated area.

1. Drain water and sediment from fuel tank when air temperature is above freezing.
2. Remove LPS 3 ® Rust Inhibitor from cylinder rods with a cleaning solvent.

LPS 3 Rust Inhibitor is manufactured by Holt Lloyd Corporation.

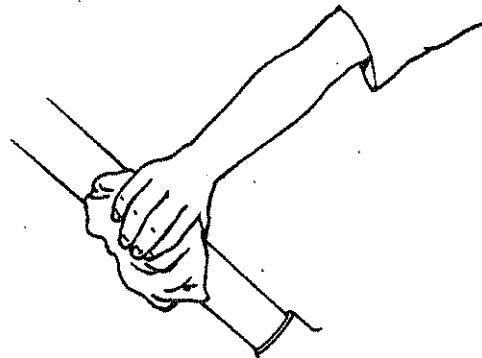

T6191AA—UN—18OCT88

Continued on next page

VD76477,00016A3 -19-08JAN08-1/2

IMPORTANT: Prevent possible engine damage.
During cold temperatures, check fluidity of engine oil on dipstick. If the oil appears waxy and/or jelly-like rather than liquid, **DO NOT** attempt to start engine. Use external heat source to warm the crankcase until oil appears fluid.

3. Check all fluid levels. If low, check for leaks and add oil as required.
4. Check belts.
5. Check condition of all hoses and connections.
6. Check battery electrolyte level. Charge and install battery.
7. For machines with **tires**, check condition of tires and tire pressure.

For machines with **tracks**, check condition of tracks and track sag.

On crawler machines with non sealed-and-lubricated track chains, apply oil to the pin-to-bushing joints. Run machine back and forth several times.

8. Park machine on a hard surface to prevent tracks from freezing to ground.
9. Fill fuel tank.
10. Pre-lubricate turbocharger bearings, if equipped:
 - a. Disconnect fuel shutoff fuse.
 - b. Crank engine for 10 seconds.
 - c. Connect fuel shutoff fuse.
11. Inspect engine compartment, and remove any foreign material that may have accumulated. Start engine and



run until it reaches operating temperature. Run at 1/2 speed for five minutes. Do not run at fast or slow idle.

- If engine fails to start or runs poorly after starting, change fuel filter(s). Bleed fuel system.

12. Operate all controls, levers, seat adjustments, etc.

CAUTION: Prevent possible injury from unexpected machine movement. Clear the area of all persons before running machine through the operation procedure.

13. Make sure the area is clear to allow for movement. Cycle all hydraulic functions several times. Check condition of all hoses and connections.
14. Park the machine with cylinder rods retracted, if possible. Turn key switch to OFF.
15. Apply LPS 3 Rust Inhibitor to exposed cylinder rod areas.

VD76477,00016A3 -19-08JAN08-2/2

T6161AU—UN—18OCT88

Miscellaneous—Machine Numbers

Record Product Identification Number (PIN)

Purchase Date _____

NOTE: Record all 13 characters of the Product Identification Number (1).

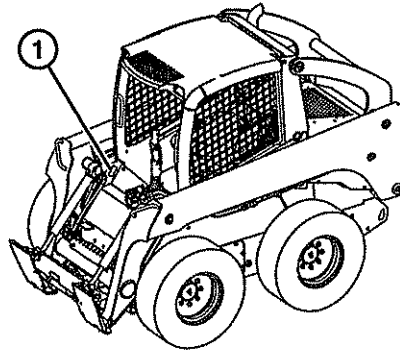

T195156—UN—25SEP03

VD76477,00000A3 -19-31JAN07-1/1

Record Engine Serial Number

Engine Serial Number (1) _____

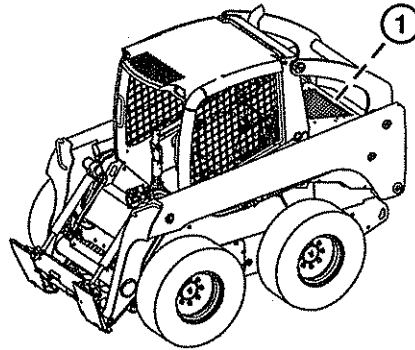

T195157—UN—25SEP03

VD76477,00000A4 -19-31JAN07-1/1

Keep Proof of Ownership

1. Maintain in a secure location an up-to-date inventory of all product and component serial numbers.
2. Regularly verify that identification plates have not been removed. Report any evidence of tampering to law enforcement agencies and order duplicate plates.
3. Other steps you can take:
 - Mark your machine with your own numbering system
 - Take color photographs from several angles of each machine

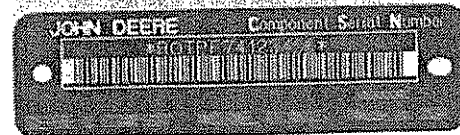
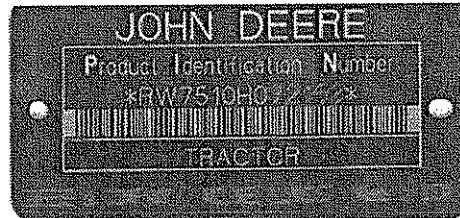

TS1680—UN—09DEC03

DX,SECURE1 -19-18NOV03-1/1

Keep Machines Secure

1. Install vandal-proof devices.
2. When machine is in storage:
 - Lower equipment to the ground
 - Set wheels to widest position to make loading more difficult
 - Remove any keys and batteries
3. When parking indoors, put large equipment in front of exits and lock your storage buildings.
4. When parking outdoors, store in a well-lighted and fenced area.
5. Make note of suspicious activity and report any thefts immediately to law enforcement agencies.
6. Notify your John Deere dealer of any losses.

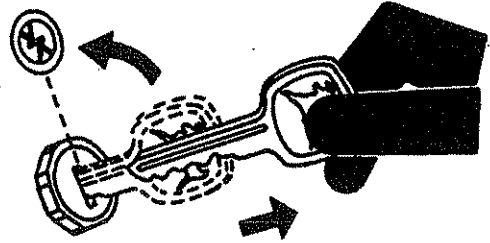

TS230 —JUN—24MAY89

DX,SECURE2 -19-18NOV03-1/1

Miscellaneous—Specifications

317 Engine Specifications

Item	Measurement	Specification
John Deere 4024T	Type Cylinders	4-Stroke Cycle, Turbocharged, Liquid Cooled 4
	Displacement	2.44 L 149 cu in.
	Net Horsepower @ 2800 RPM	42.5 kw 57.0 hp

Item	Measurement	Specification
Electrical System	Type Charging System	12 Volt, Electric Start Alternator, 70 Amp
	Battery	750 CCA (cold cranking amps)

TX14740,00000E3 -19-31JAN07-1/1

320 Engine Specifications

Item	Measurement	Specification
John Deere 4024T	Type Bore and Stroke	4-Stroke Cycle, Turbocharged, Liquid Cooled 86 x 105 mm 3.386 x 4.134
	Cylinders	4
	Displacement	2.44 L 147 cu in.
	Net Horsepower @ 2800 rpm	46.2 kw 62.0 hp

Item	Measurement	Specification
Electrical System	Type Charging System	12 Volt, Electric Start Alternator, 70 Amp
	Battery	750 CCA (cold cranking amps)

TX14740,000010C -19-14MAR07-1/1

Miscellaneous—Specifications

317 and 320 Drain and Refill Capacities

Item	Measurement	Specification
Fuel Tank	Capacity	60.6 L 16.0 gal
Cooling System	Capacity	6.6 L 7.0 qt
Engine Oil, (including filter)	Capacity	9.0 L 9.5 qt
Hydraulic Tank	Capacity	19.0 L 5.0 gal
Chain Case (per side)	Capacity	7.1 L 1.9 gal

DW90712,00001D7 -19-31JAN07-1/1

Miscellaneous—Specifications

317 Machine Dimensions

NOTE: Specifications and design subject to change without notice. Wherever applicable, specifications are in accordance with ISO and SAE standards.

Except where otherwise noted these specifications are based on a machine equipped with standard tires and bucket.

Item	Measurement	Specification	
Model 317	Overall Length (less bucket)	2591 mm 102.0 in.	
	Overall Length (with bucket)	3195 mm 125.8 in.	
	Overall Width (less bucket)	1618 mm 63.7 in.	
	Height to ROPS	1915 mm 75.4 in.	
	Height to Hinge Pin	2896 mm 114.0 in.	
	Dump Reach (Foundry Bucket)	739 mm 29.1 in.	
	Dump Reach (Construction Bucket)	914 mm 36.0 in.	
	Dump Angle	45 degrees	
	Bucket Rollback	35 degrees	
	Wheelbase	1074 mm 42.3 in.	
	Ground Clearance	208 mm 8.2 in.	
	Angle of Departure	27 degrees	
	Standard Tire Size	10 x 16.5 8-PR	
	Item	Measurement	Specification
	Model 317	Operating Weight	2858 kg 6300 lb

TX14740,00000E4 -19-22OCT07-1/1

Miscellaneous—Specifications

320 Machine Dimensions

NOTE: Specifications and design subject to change without notice. Wherever applicable, specifications are in accordance with ISO and SAE standards.

Except where otherwise noted these specifications are based on a machine equipped with standard tires and bucket.

Item	Measurement	Specification	
Model 320	Overall Length (less bucket)	2591 mm 102.0 in.	
	Overall Length (with bucket)	3195 mm 125.8 in.	
	Overall Width (less bucket)	1750 mm 68.9 in.	
	Height to ROPS	1951 mm 76.8 in.	
	Height to Hinge Pin	2.926 mm 115.2 in.	
	Dump Reach (Foundry Bucket)	714 mm 28.1 in.	
	Dump Reach (Construction Bucket)	899 mm 35.0 in.	
	Bucket Rollback	35 degrees	
	Dump Angle	45 degrees	
	Wheelbase	1074 mm 42.3 in.	
	Ground Clearance	244 mm 9.6 in.	
	Angle of Departure	27 degrees	
	Standard Tire Size	12 x 16.5 10-PR	
	Item	Measurement	Specification
	Model 320	Operating Weight	2919 kg 6435 lb

TX14740,00000E6 -19-14MAR07-1/1

Miscellaneous—Specifications

317 Tire Options and Pressures

Item	Measurement	Specification
10 x 16.5 - SKS Extra-Wall, 8PR	Pressure	379-414 kPa 55-60 psi
10 x 16.5 - SKS Hauler Heavy Duty, 8PR	Pressure	379-414 kPa 55-60 psi
10 x 16.5 - Galaxy "Beefy Baby II" Heavy Duty, 8PR	Pressure	310-414 kPa 45-60 psi
12 x 16.5 - SKS Extra-Wall, 10PR	Pressure	414-448 kPa 60-65 psi
12 x 16.5 - SKS Hauler Heavy Duty, 10PR	Pressure	414-448 kPa 60-65 psi
31.5/1300 x 16.5 - Galaxy "Hippo" Flotation, 10PR	Pressure	241-414 kPa 35-60 psi
10 x 16.5 - SuperFlex Foam Filled Galaxy "Beefy Baby II", 8PR	Pressure	N/A
10 x 16.5 - Mitco "Duro Cushion" Solid	Pressure	N/A

TX14740,00000E7 -19-31JAN07-1/1

Miscellaneous—Specifications

320 Tire Options and Pressures

Item	Measurement	Specification
10 x 16.5 - SKS Extra-Wall, 8PR	Pressure	379-414 kPa 55-60 psi
10 x 16.5 - SKS Hauler Heavy Duty, 8PR	Pressure	379-414 kPa 55-60 psi
10 x 16.5 - Galaxy "Beefy Baby II" Heavy Duty, 8PR	Pressure	310-414 kPa 45-60 psi
10 x 16.5 - SuperFlex Foam Filled Galaxy "Beefy Baby II", 8PR	Pressure	N/A
12 x 16.5 - SKS Standard Duty, 8PR	Pressure	324-365 kPa 47-53 psi
12 x 16.5 - SKS Extra-Wall, 10PR	Pressure	414-448 kPa 60-65 psi
12 x 16.5 - SKS Hauler Heavy Duty, 10PR	Pressure	414-448 kPa 60-65 psi
31.5/1300 x 16.5 - Galaxy "Hippo" Flotation, 10PR	Pressure	241-414 kPa 35-60 psi
33/1550 x 16.5 - Galaxy "Hippo" Flotation, 12PR	Pressure	241-414 kPa 35-60 psi
12 x 16.5 - Galaxy "Beefy Baby II" Heavy Duty, 10PR	Pressure	276-448 kPa 40-65 psi
12 x 16.5 - SuperFlex Foam Filled Galaxy "Beefy Baby II", 10PR	Pressure	N/A
8 x 16 - Mitco "Duro Cushion" Solid	Pressure	N/A

TX14740,00000EB -19-31JAN07-1/1

Pallet Fork Lift Chart

Pallet Fork Lift Chart		
Pallet Fork	317 (Without Counterweight)	317 (With Counterweight)
1070 mm (42 in.)	476 kg (1050 lb)	581 kg (1281 lb)
1220 mm (48 in.)	476 kg (1050 lb)	581 kg (1281 lb)
Pallet Fork	320 (Without Counterweight)	320 (With Counterweight)
1070 mm (42 in.)	501 kg (1105 lb)	606 kg (1336 lb)
1220 mm (48 in.)	501 kg (1105 lb)	606 kg (1336 lb)

Rating based on SAE J1197. Load at 50% tipping capacity and 50% of fork length and fork height giving maximum reach.

DW90712,000009F -19-31JAN07-1/1

Miscellaneous—Specifications

Index

	Page	Page
A		
Acid burns.....	3-6-4	
Air conditioner		
Switch.....	2-1-1	
Air conditioner and heater blower		
Switch.....	2-1-1	
Air conditioning		
Condenser check.....	4-1-1	
Air conditioning and heating system		
Check.....	4-2-6	
Air conditioning controls.....	2-1-10	
Air filters		
Cleaning air conditioner.....	4-1-3	
Cleaning heater/defroster air filters.....	4-1-3	
Air to air cooler		
Check.....	4-1-1	
Anti-theft security system.....	2-1-5	
Changing a security code.....	2-1-6	
Enable or disable the auto lock feature.....	2-1-5	
Locking the machine.....	2-1-5	
Overview.....	2-1-3	
Unlocking the machine.....	2-1-5	
Armrest adjustment.....	2-1-12	
Attachment		
Installing.....	2-2-5, 2-2-12, 2-2-13	
Removing.....	2-2-5, 2-2-12, 2-2-13	
Attachment mounting system.....	2-2-5	
Electric Quik-Tatch.....	2-2-13	
Hydraulic Quik-Tatch.....	2-2-12	
Attachments		
Adding safely.....	1-3-4	
Operating safely.....	1-3-4	
Auto shutdown.....	2-1-9	
Auxiliary hydraulic override		
Check.....	4-2-4	
Switch.....	2-1-1	
Auxiliary water separator fuel filter		
Check.....	3-3-3	
Auxiliary water separator fuel filter-if equipped		
Replace.....	3-6-6	
B		
Back-up alarm		
Check.....	4-2-5	
Backover accidents		
Avoiding.....	1-3-3	
Batteries		
Booster batteries.....	4-1-7	
Battery		
Acid burns.....	3-6-4	
Electrolyte level check.....	3-6-4	
Explosion.....	3-6-4	
Removal.....	4-1-6	
Terminals.....	3-6-4	
Battery charger		
Using.....	4-1-5	
Battery electrolyte level		
Checking.....	4-1-4	
Battery explosions		
Prevent.....	1-2-4	
Beacon light if equipped		
Operational check.....	4-2-2	
Beacon—if equipped		
Operators station.....	2-1-12	
Belt		
Replacing.....	4-1-1	
Bleed		
Fuel system.....	3-6-1	
Blower motor fuse.....	4-1-8	
Boom and bucket linkage		
Adjusting—hands only machine.....	4-1-2	
Boom enable		
Check.....	4-2-3	
Boom lock.....	2-2-6	
Boom operation		
Hand foot machines.....	2-2-9	
Hands only machine.....	2-2-11	
Boom release		
Standard controls.....	2-2-7	
Boost starting.....	4-1-7	
Breather element		
Replace.....	3-6-2	
Bucket enable		
Check.....	4-2-3	
Bucket operation		
Hand foot machines.....	2-2-10	
Hands only machine.....	2-2-11	
C		
Cab door switch		
Indicator.....	2-1-8	
Cab temperature control dial.....	2-1-1	
Capacities		
Drain and refill.....	4-6-2	
Chain case		
Oil level check.....	3-6-3	
Oil specification.....	3-1-6	
Chain case oil		
Change.....	3-7-1	
Chemical products		
Safe handling.....	1-2-4	
Clean oil cooler.....	3-3-2	
Clean radiator.....	3-3-2	
Cleaning air conditioner filters.....	4-1-3	
Cleaning heater/defroster air filters.....	4-1-3	
Closing engine cover.....	3-2-2	
Cold weather starting.....	2-2-2	
Coolant		
Additional information.....	3-1-11	
Diesel engine		
Light duty.....	3-1-8	

Continued on next page

Index

	Page		Page
Heater	2-2-3	Engine coolant temperature gauge	2-1-8
John Deere COOL-GARD II COOLANT EXTENDER.....	3-1-9	Engine cover Opening and closing	3-2-2
Supplemental additives.....	3-1-10	Engine low oil pressure Indicator	2-1-8
Testing.....	3-1-12	Engine serial number.....	4-5-1
Warm temperature climates	3-1-10	Engine specifications.....	4-6-1
Cooling		Engine speed	
System drain	3-8-1	Check.....	4-2-6
Cooling system		Entering skid steer.....	2-2-1
Filling.....	3-8-2	Exhaust fumes.....	1-2-3
Flushing.....	3-8-1	Exiting skid steer	2-2-1
Coolsan Plus.....	3-2-5	Explosion	
Cover plates		Battery.....	1-2-4
Removing.....	3-2-4		
D		F	
Daily machine check.....	2-2-1	Filling cooling system	3-8-2
Diagnostic display items		Filter	
Engagement and monitor unit.....	2-1-7	Engine oil replace	3-5-2, 3-6-5
Diagnostic trouble codes		Fuel water separator drain.....	3-3-3
Reading from engagement and monitor unit.....	2-1-7	Fuel water separator replace	3-6-1
Diesel fuel.....	3-1-1, 3-1-2	Hydraulic oil replace.....	3-6-3
Diesel fuel conditioner		In-line fuel replace.....	3-6-1
Low sulfur.....	3-1-3	Fire prevention.....	1-2-4
Dome Light	2-1-10	Flushing cooling system	3-8-1
Dual flasher		Foot pedal	
Switch	2-1-1	Lubrication	3-6-7
E		Fuel	
EH Controls		Diesel.....	3-1-1, 3-1-2
Instrument panel	2-1-1	Handling and storing	3-1-3
Electric quik-tatch		Fuel filter	
Check.....	4-2-5	Water separator fuel filter.....	3-6-6
Electric Quik-Tatch		Fuel filter, auxiliary water separator	
Attachment mounting system.....	2-2-13	Check.....	3-3-3
Electrical		Fuel gauge.....	2-1-8
Troubleshooting	4-3-2	Fuel system	
Emergency preparation	1-2-5	Bleed.....	3-6-1
Engagement and monitor unit	2-1-1	Fuel tank.....	3-2-1
Data items	2-1-7	Fuel water separator	
Diagnostic display items	2-1-7	Filter drain	3-3-3
Operation	2-1-3	Fuel water separator filter	
Reading diagnostic trouble codes.....	2-1-7	Replace.....	3-6-1
Run data items.....	2-1-7	Functions	
Engine		Instrument panel	2-1-2
Cold start.....	2-2-2	Fuses.....	4-1-7
Oil change.....	3-5-2, 3-6-5		
Oil filter replace.....	3-5-2, 3-6-5	G	
Oil level check.....	3-3-1	Gauge and indicator light	
Reading diagnostic trouble codes.....	2-1-7	Functions	2-1-8
Start check.....	4-2-3	Gauge circuit	
Starting.....	2-2-2	Check, key off	4-2-1
Stopping.....	2-2-13	Check, key on	4-2-2
Troubleshooting	4-3-1	Gauge functions	2-1-8
Warm-up	2-2-4	Gauges.....	2-1-8
Engine air filter restriction		Glow plug	
Indicator	2-1-8	Fuse.....	4-1-9
		Indicator	2-1-8

Continued on next page

Index

	Page		Page
Grease		Hydraulic quik-tatch	
Alternative and synthetic lubricants	3-1-3	Check.....	4-2-5
Boom cylinders, bucket cylinders, and		Hydraulic Quik-Tatch	
QUIK-TATCH.....	3-1-7	Attachment mounting system.....	2-2-12
H			
Hand foot machines		Hydraulics	
Adjusting hydraulic linkage	4-1-2	Hand foot machines	2-2-8
Boom operation.....	2-2-9	Hands only machines.....	2-2-11
Bucket operation	2-2-10	Hydraulics Off	
Hydraulics	2-2-8	Indicator	2-1-8
Hand-foot machine		Hydrostatic	
Armrests, Adjusting.....	2-1-12	Oil specification.....	3-1-6
Handhold use	1-3-1	I	
Handling chemicals	1-2-4	In-line fuel filter	
Hands only machine		Replace.....	3-6-1
Adjusting boom and bucket linkage	4-1-2	Inch torque values	4-1-10
Boom and bucket operation	2-2-11	Indicator	
Hydraulics	2-2-11	Cab door switch	2-1-8
Hands-only machine		Engine air filter restriction	2-1-8
Armrests, Adjusting.....	2-1-12	Engine low oil pressure.....	2-1-8
Hazards		Glow plug.....	2-1-8
Avoiding	1-3-2	High speed.....	2-1-8
Heater		Hydraulic oil filter restriction	2-1-8
Coolant.....	2-2-3	Hydraulic oil temperature.....	2-1-8
Engine block	2-2-3	Hydraulics OFF	2-1-8
Heater controls	2-1-10	Low alternator or battery voltage	2-1-8
Heating and air conditioning system		Seat belt switch.....	2-1-8
Check.....	4-2-6	Seat switch.....	2-1-8
High flow		STOP	2-1-8
Switch	2-1-1	Indicator light functions.....	2-1-8
High speed		Indicator lights	2-1-8
Indicator.....	2-1-8	Indicators and gauges	
High-pressure oils		Check, key off	4-2-1
Avoid	1-2-3	Check, key on	4-2-2
Horn button.....	2-1-9	Inspect machine	1-2-2
Horn circuit		Instrument panel	
Check.....	4-2-2	EH controlled machine.....	2-1-1
Hydraulic		Instrument panel functions	2-1-2
Oil change.....	3-7-2	J	
Oil cooler		Jump starting.....	4-1-7
Check	4-1-1	K	
Oil filter replace	3-6-3	Key switch	2-1-1
Oil level check.....	3-3-1	Key switch off, engine off checks	4-2-1
Oil specification.....	3-1-6	Key switch on, engine off checks	4-2-1
Oil tank breather element replace.....	3-6-2	Key switch on, engine on checks	4-2-3
Troubleshooting	4-3-3	L	
Hydraulic control enable		Lever	
Check.....	4-2-3	Boom control.....	2-1-1
Hydraulic linkage		Bucket control	2-1-1
Adjusting hand foot machines.....	4-1-2	Lift chart	
Hydraulic oil filter restriction		Pallet fork.....	4-6-6
Indicator	2-1-8		
Hydraulic oil temperature			
Indicator	2-1-8		
Hydraulic override			
Check.....	4-2-4		

Continued on next page

Index

	Page		Page
Lights circuit		Operational checkout.....	4-2-1
Check.....	4-2-2	Operator convenience	1-1-1
Low alternator or battery voltage		Operators station	
Indicator	2-1-8	Beacon light	2-1-12
Low sulfur diesel fuel conditioner	3-1-3		
Lubricants		P	
Alternative and synthetic lubricants	3-1-3	Pallet fork lift chart.....	4-6-6
Lubricate		Park brake	
Boom linkage	3-4-1	Check.....	4-2-4
Cylinder pivots	3-4-1	Indicator	2-1-8
QUIK-TATCH	3-4-1	Switch	2-1-1
Steering linkage	3-6-6	Pedal	
M		Boom control.....	2-1-1
Machine		Bucket control	2-1-1
Raising and blocking.....	3-2-1	Pedal angle	
Service	3-2-1	Adjusting	4-1-3
Trailer loading	2-2-14	Pilot control shutoff lever	1-3-1
Machine dimensions.....	4-6-3, 4-6-4	Pins, metal	
Machine inspection.....	1-2-2	Drive safely	1-4-2
Machine modifications		Power Outlet.....	2-1-9
Avoid.....	1-2-2	Pre-start inspection.....	2-2-1
Machine movement		Primary air cleaner element	
Unintended.....	1-3-1	Replace.....	3-6-2
Machine specifications	4-6-1	Product identification number	4-5-1
Machine tip over		Protective equipment.....	1-2-2
Avoiding	1-3-3	Public roads	
Maintenance		Operating and traveling.....	1-3-3
Record keeping.....	3-2-4	Q	
Required parts	3-2-7	Quik-Tatch	2-2-5
Schedule and record.....	3-2-6	Electric	2-2-13
MENU button.....	2-1-1, 2-1-8	Hydraulic.....	2-2-12
Metric torque values	4-1-11	Switch	2-1-1
Monitor		R	
Display items.....	2-1-7	Radiator	
Monitor and gauge circuit		Check.....	4-1-1
Check, key off	4-2-1	Coolant level check.....	3-3-2
Check, key on	4-2-2	Radiator and oil cooler.....	3-3-2
Moving parts		Raising and blocking	
Safety.....	1-2-2	Machine	3-2-1
Servicing	1-2-2	Raising operator's station	3-2-3
O		Reading engagement and monitor unit	
Oil		diagnostic trouble codes	2-1-7
Alternative and synthetic lubricants	3-1-3	Rear service door	3-2-1
Engine replace	3-5-2, 3-6-5	Replacing air conditioner filters	4-1-3
Hydraulic change	3-7-2	Replacing heater/defroster air filters.....	4-1-3
Level check hydraulic.....	3-3-1	Reverse alarm	
Level check, chain case.....	3-6-3	Check.....	4-2-5
Level check, engine	3-3-1	Riding machine.....	1-3-2
Specification chain case	3-1-6	Run data items	
Specification hydraulic	3-1-6	Engagement and monitor unit.....	2-1-7
Specification hydrostatic	3-1-6		
Oilscan Plus.....	3-2-5		
Opening engine cover	3-2-2		
Operating on public roads	1-3-3		
Operation qualification.....	1-2-1		

Continued on next page

Index

	Page		Page
S			
Safety		Storage	
Operator's seat	1-3-1	Machine	4-4-1
Park and prepare for service safely	1-4-1	Monthly	4-4-1
Safety equipment.....	1-2-2	Storing fuel	3-1-3
Safety features	1-1-1	Suspension seat.....	2-1-11
Safety information		Switch	
Recognizing	1-2-1	Air conditioner	2-1-1
Safety instructions	1-2-1	Air conditioner and heater blower	2-1-1
Safety signs	1-5-1	Auxiliary hydraulic override	2-1-1
Safety symbols	1-2-1	Dual flasher.....	2-1-1
Seat	2-1-11	High flow	2-1-1
Suspension	2-1-11	Park brake.....	2-1-1
Seat belt		Quik-Tatch.....	2-1-1
Use and maintenance	1-3-1	Windshield wiper/washer	2-1-1
Seat belt switch		Work lights	2-1-1
Indicator	2-1-8	T	
Seat switch		Tail lights	
Indicator	2-1-8	Check.....	4-2-2
Secondary air cleaner element		Tip over	
Replace.....	3-7-1	Avoiding	1-3-3
Secondary exit.....	2-1-11	Tire	
Security system		Pressure check	3-4-2
Anti-theft.....	2-1-5	Tire options and pressures	4-6-5, 4-6-6
SELECT button.....	2-1-1, 2-1-8	Tire pressure	
Self-Leveling (If Equipped)	2-2-4	Pressure tire.....	3-4-2, 3-4-3
Serial number		Torque values	
Engine.....	4-5-1	Inch	4-1-10
Service		Metric	4-1-11
Machine	3-2-1	Transporting machine.....	2-2-14
Side panels		Traveling on public roads	1-3-3
Removing.....	3-2-2	Troubleshooting procedure.....	4-3-1
Signs		U	
Safety.....	1-5-1	Using	
Skid steer		Battery charger	4-1-5
Entering.....	2-2-1	W	
Exiting	2-2-1	Waste disposal	1-2-5
Specification		Water seperator	
Chain case oil	3-1-6	Fuel filter repalce	3-6-6
Hydraulic oil	3-1-6	Welding repairs	
Hydrostatic oil	3-1-6	Make safety.....	1-4-2
Standard controls		Wheel	
Boom control.....	2-1-1	Lug nut torque check	3-5-1
Boom release.....	2-2-7	Windshied wiper circuit	
Bucket control	2-1-1	Check.....	4-2-3
Controls and pedals	2-1-1	Windshield washer circuit	
Pedals and controls	2-1-1	Check.....	4-2-3
Starting		Windshield wiper/washer	
Cold weather.....	2-2-2	Switch	2-1-1
Engine.....	2-2-2	Work lights	
Steering levers.....	2-2-7	Check.....	4-2-2
Steering linkage		Switch	2-1-1
Lubricate	3-6-6	Work site hazards	
Steps use.....	1-3-1	Avoid	1-3-2
STOP			
Indicator	2-1-8		
Stopping			
The engine	2-2-13		

Index