



Important information

Serious risk of injury

When work is being carried out on the engine (such as adjusting drive belts, changing oil or adjusting the clutch), it is important not to start the engine. The engine could be damaged, but more importantly there is a serious risk of injury.

For this reason, always secure the starting device or disconnect a battery cable before working on the engine. This is especially important if the engine has a remote starter or automatic starting.



WARNING!

This warning symbol and text can be found next to those inspection points where it is particularly important to bear in mind the risk of injury.

Operator's manual

DC13

PDE

Industrial engine

en-GB 2 161 082

Issue 1.0

Start-up Report - Warranty

When the start-up report has been filled in and sent to Scania, you have a 1-year warranty from the date of entry into service. Fill in the particulars below as well. This can make things easier if you need to contact a workshop for example.

Engine serial number

Start of warranty date

Owner's name and address

Signature

Engine type

Variant

Engine type and variant are indicated on the engine type plate.

Preface

This operator's manual describes the operation and inspection of Scania industrial engines.

The engines are direct-injection, liquid-cooled, four-stroke, turbocharged diesel engines.

The engines are available with different output and speed settings. The normal output setting of the engine (performance code) is indicated on the engine type plate.

Note:

Only standard components are described in the Operator's manual. Information about special equipment is contained in instructions from the various manufacturers.

To ensure the maximum performance and the longest service life for the engine remember the following:

- Read through the Operator's manual before starting to use the engine. Even regular users of Scania engines will get new information from the Operator's manual.
- Always follow the inspection instructions.
- Read the section on safety carefully.
- Get to know your engine so that you know what it can do and how it works.
- Always contact an authorised Scania workshop.

The information in this manual was correct at the time of going to press. Scania reserves the right to make alterations without prior notice.

Note:

Always use Scania spare parts for service and repair.

Preface	2	Preparing the engine for storage	63
Environment and safety	4	Handling the engine	63
Environmental responsibility	4	Preservative coolant	64
Safety	4	Preservative fuel	64
Warnings and advisories	6	Preservative oil	64
Certification	15	Preparations for storage	65
Type designations	16	Technical data	68
Component identification	17	General data	68
Engine management system	18	Lubrication system	68
Starting and running	19	Injection system	69
Checks before running	19	Cooling system	69
Starting the engine	20	Intake system	69
Running	21	Electrical system	69
Engine shutdown	24	Diesel	70
Checks after running	25	Composition of the fuel	70
Inspection	26	Temperature dependency of the fuel	71
Engines with few hours of operation	27	Scania Assistance	72
Inspection interval	28		
Lubrication system	29		
Oil grade	29		
Oil analysis	31		
Checking oil level	31		
Changing the oil	32		
Cleaning the centrifugal oil cleaner	33		
Renewing the oil filter	36		
Cooling system	37		
Coolant	37		
Checking coolant level	40		
Checking the coolant level monitor	41		
Checking antifreeze and corrosion inhibitor	42		
Antifreeze and corrosion inhibitor	43		
Changing coolant	44		
Cleaning the cooling system	46		
Air cleaner	49		
Reading the vacuum indicator	49		
Renewing the filter element	49		
Renewing the safety cartridge	50		
Fuel system	51		
Checking fuel level	51		
Renewing the fuel filter	51		
Renewing the water separating fuel filter	52		
Bleeding the fuel system	53		
Electrical system	54		
General information on batteries	54		
Checking the electrolyte level in batteries	55		
Checking state of charge	55		
Cleaning the batteries	56		
Renewing the battery	56		
Checking the coolant level monitor	56		
Miscellaneous	57		
Checking the drive belt	57		
Checking for leaks	59		
Checking and adjusting the valve clearance	59		

Environment and safety

Environmental responsibility

Scania develops and produces engines that are as environmentally-friendly as possible. Scania has made major investments in the reduction of harmful exhaust emissions in order to fulfil the environmental requirements in force in almost every market.

At the same time, we have been able to maintain a high level of performance and operating economy for Scania Industrial and Marine Engines. To maintain these throughout the entire service life of the engine, it is important to follow the instructions on running, inspection and the selection of fuel and lubricating oil as outlined in the Operator's manual.

Other green initiatives taken include ensuring that, following inspection and repair, waste that is harmful to the environment (for example oil, fuel, coolant, filters and batteries) are disposed of in accordance with the applicable environmental requirements.

Safety

The next pages contain a summary of the safety regulations to be followed when operating and inspecting Scania engines. The equivalent text can also be found under the relevant inspection point.

To prevent damage to the engine and to ensure that it runs optimally, follow the instructions in the warnings and advisories.

Failure to follow the instructions could void the warranty.

Different types of advisory

Warning!

All advisories preceded by the word Warning are very important. They warn of serious faults and incorrect operation that could lead to personal injury. Example:



WARNING!

Block the starting device when working on the engine. If the engine starts unexpectedly, there is a serious risk of injury.

Important!

Advisories preceded by the word Important warn of faults and incorrect operation that could lead to equipment being damaged. Example:



IMPORTANT!

If inspection and maintenance are not carried out as above, Scania can no longer take responsibility for damage that occurs.

Note:

Advisories preceded by Note: refer to information important to ensure the best possible operation and functionality. Example:

Note:

Always use genuine Scania parts during inspection and repair so as to keep your engine in the best possible working order.

Environment

This Operator's manual contains specially highlighted text with instructions to help protect the environment during inspection and maintenance. Example:



Environment

Use a container to avoid spillage.

Warnings and advisories

Smoking



WARNING!

Smoking is prohibited

- in the vicinity of flammable or explosive material, e.g. fuel, oils, batteries, chemicals
 - when refuelling and in the vicinity of the filling station
 - when working on the fuel system
-

Safety precautions for running the engine

Daily inspection

Always carry out a visual inspection of the engine and engine compartment before starting the engine and when the engine has been switched off after operation.

This inspection should be done to detect fuel, oil or coolant leaks, or anything else that may require corrective action.

Fuel

Use only fuel recommended in the workshop literature.



WARNING!

The wrong fuel grade can cause breakdowns or stoppages by causing the injection system to malfunction. This can cause damage to the engine and, possibly, personal injury.

Fuel filling

Never overfill the fuel tank as the fuel needs space to expand.
Also ensure that the filler cap is properly closed.



WARNING!

During refuelling there is a risk of fire and explosion. The engine must be switched off and smoking is prohibited.

Hazardous gases



WARNING!

Only start the engine in a well ventilated area. The exhaust gases contain carbon monoxide and nitrogen oxides, which are toxic.

If it is run in an enclosed space, there should be an effective device to extract exhaust gases and crankcase gases.

Starter lock



IMPORTANT!

If the control panel is not fitted with a starter lock, the engine compartment should be locked to prevent unauthorised personnel from starting the engine. Alternatively, a lockable master switch or battery master switch can be used.

Starter gas



WARNING! _____

Never use starter gas or similar agents to help start the engine. This can cause an explosion in the intake manifold and possible injury.

Running



WARNING! _____

The engine must not be run in environments where there is a risk of explosion, as all of the electrical or mechanical components can generate sparks.

Approaching a running engine always poses a safety risk. Parts of the body, clothes or dropped tools can get caught in rotating parts such as the fan and cause injury. For personal safety all rotating parts and hot surfaces must be fitted with guards.

Safety precautions for handling materials

Fuel and oil



WARNING!

All fuels and lubricants as well as many chemicals are flammable. Always follow the instructions on the relevant packaging.

The work must be carried out on a cold engine. Fuel leaks and spillage on hot surfaces can cause fire.

Store used rags and other flammable materials safely so as to avoid spontaneous combustion.

Batteries



WARNING!

The batteries contain and form oxyhydrogen gas, particularly during charging. This is flammable and highly explosive. There must be no smoking, naked flames or sparks near the batteries or the battery compartment.

Incorrect connection of a battery cable or jump lead can cause a spark, which in turn can cause the battery to explode.

Chemicals



WARNING!

Most chemicals such as glycol, anti-corrosive agents, preservative oils and degreasing agents, are hazardous to health.

Some chemicals, such as preservative oil, are also flammable.

Always follow the safety precautions on the relevant packaging.

Store chemicals and other materials which are hazardous to health in approved containers, marking them clearly and storing them where they are inaccessible to unauthorised persons.



Environment

Always hand in leftover and used chemicals to an authorised waste disposal contractor.

Safety precautions for inspection and maintenance

Switch off the engine

- Always switch off the engine before carrying out inspections and repairs, unless otherwise indicated.
- Make it impossible to start the engine: Remove any starter key, or cut the power using the main power switch or battery master switch and lock them.
- Fix a warning plate somewhere appropriate, showing that work is being carried out on the engine.



WARNING!

Working with a running engine always poses a safety risk. Parts of the body, clothes or dropped tools can get caught in rotating parts and cause injury.

Hot surfaces and fluids



WARNING!

There is always a risk of sustaining burns when an engine is hot. Particularly hot parts are engine manifolds, turbochargers, oil sumps, hot coolant and oil in pipes and hoses.

Lifting the engine

Always use the engine lifting eyes. Always check that lifting devices are in good condition and are designed to lift the weight.

Optional equipment on the engine can change the centre of gravity. This means that it may be necessary to use additional lifting devices to balance the engine correctly and lift it safely.



WARNING!

Never work underneath a suspended engine!

Batteries



WARNING!

The batteries contain highly corrosive sulphuric acid. Take care to protect your eyes, skin and clothes when charging or handling batteries. Wear protective gloves and goggles.

If sulphuric acid comes into contact with your skin, wash it off with soap and plenty of water. If acid splashes in your eyes, flush them immediately with copious amounts of water and contact a doctor.

Dispose of used batteries through an authorised waste disposal contractor.

Electrical system

The engine must be stopped and the power disconnected using the master switch or battery master switch before working on the electrical system. External power supplies to extra equipment on the engine must also be disconnected.



IMPORTANT!

Always use Scania spare parts for the fuel and electrical systems. Scania spare parts are designed to minimise the risk of fire and explosion.

Electric welding



IMPORTANT!

When carrying out welding work on and near the engine, disconnect the battery and alternator leads. Pull out the multi-pin connector for the control unit as well.

Connect the welding clamp as close to the welding site on the component as possible. The welding clamp must not be connected to the engine, or so that the current can cross a bearing.

When welding is finished:

1. Connect the alternator and control unit cables first.
 2. Then connect the batteries.
-

Lubrication system



WARNING!

Hot oil can cause burns and skin irritation. Wear protective gloves and goggles when changing hot oil.

Make sure that there is no pressure in the lubrication system before starting work on it.

The oil filler cap must always be in place when starting and running the engine to prevent oil being ejected.



Environment

Dispose of used oil through an authorised waste disposal contractor.

Cooling system



WARNING!

Never open the coolant filler cap when the engine is hot. Hot coolant and steam may spray out and cause burns.

If the cap has to be opened do it slowly and carefully to release the pressure before removing the cap. Wear gloves as the coolant is still very hot.



Environment

Dispose of used coolant through an authorised waste disposal contractor.

Fuel system



WARNING!

Always wear protective goggles when testing injectors. Fuel escaping at high pressure can penetrate tissues and cause serious injury.

Always use Scania spare parts for the fuel and electrical systems. Scania spare parts are designed to minimise the risk of fire and explosion.

Before starting

Ensure that all guards are in place before starting the engine. Ensure that no tools or other objects have been left on the engine.



WARNING!

The air filter must be fitted before starting the engine. Otherwise there is a risk of objects being sucked into the compressor impeller or of injury if you come into contact with it.

Certification

An emissions certified engine fulfils the emissions requirements for a particular range of application.

On each emissions certified engine type there is a label which shows which requirements the engine fulfils. Scania guarantees that each such engine fulfils the emissions requirements for the range of application for which it is certified.

The following are required for the certified engine to fulfil the emissions requirements once it has been taken into service:

- Inspection and maintenance are to be carried out following the instructions in this Operator's manual.
- The inspection, maintenance and repair of injection equipment are to be carried out by an authorised Scania workshop.
- The engine may only be modified with equipment that has been approved by Scania.
- Seals may be broken and setting data edited only once approval has been granted by Scania. Modifications may be made by authorised personnel only.
- Modifications affecting the exhaust and intake systems must be approved by Scania.

Otherwise, the instructions in the Operator's manual for the operation, inspection and maintenance of the engine shall apply. The safety precautions on the following pages must be observed.



IMPORTANT!

For Scania to guarantee that the engine corresponds to its certified design, and take responsibility for any damage and injuries that occur, inspection and maintenance must be carried out as above.

Type designations

The engine type designation indicates, in the form of a code, the engine type, its size and applications. The engine serial number is stamped onto the top of the cylinder block at the front right. The type designation is shown on the type plate.

The engine EU type approval for exhaust emissions is indicated under Output, where applicable.

Example: DC13 074A

- DC Supercharged diesel engine with air-cooled charge air cooler.
- 13 Displacement in whole dm³.
- 074 Performance and certification code. The code indicates, together with the application code, the normal gross engine output.
- A Code for application. A means for general industrial use.



Component identification

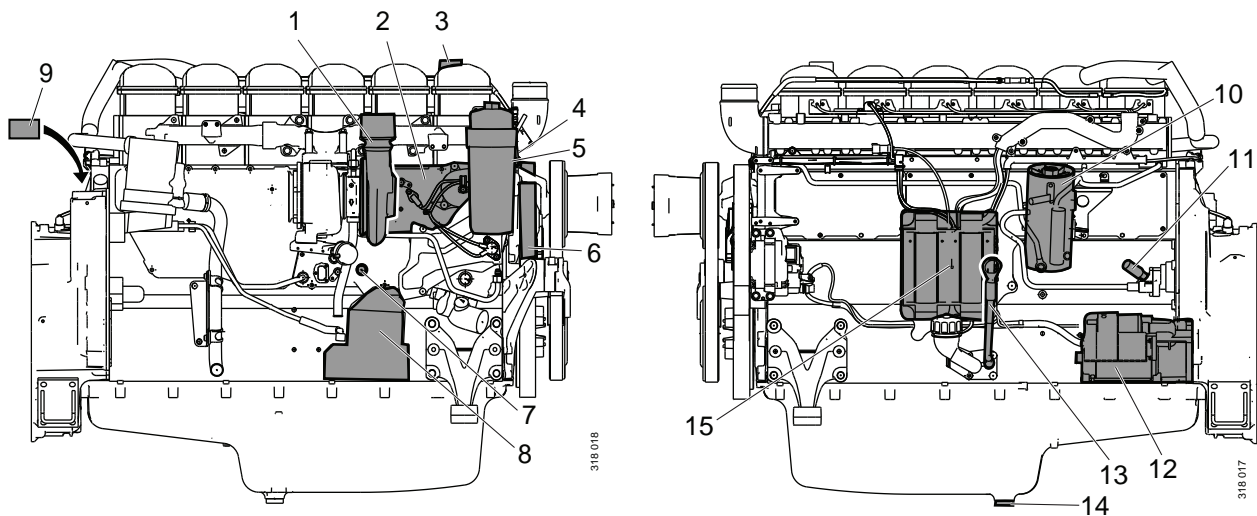

The illustrations show a normal version of a DC13 engine. The engine ordered may have different equipment.

Note:

The water separating prefilter for the fuel is located between the fuel tank and engine.

- | | |
|---|------------------------------|
| 1. Turbocharger | 9. Type designation |
| 2. Oil cooler | 10. Fuel filter |
| 3. Oil filler | 11. Fuel pump with hand pump |
| 4. Engine serial number on the cylinder block | 12. Starter motor |
| 5. Oil filter | 13. Oil dipstick |
| 6. Coolant pump | 14. Oil plug |
| 7. Coolant drain tap | 15. Engine control unit |
| 8. Centrifugal oil cleaner | |

Engine management system

The engine is equipped with the electronic control system EMS (Engine Management System). The engine management system ensures that each cylinder receives the correct quantity of fuel at the right time in each operating situation.

The engine management system consists of a control unit and a number of sensors, which report the following:

- engine speed
- charge air temperature
- charge air pressure
- coolant temperature
- oil pressure
- throttle actuation.

Guided by this information, the system calculates the correct quantity of fuel and the correct injection timing for each injector in the relevant operating situation.

The sensors can also send signals to instruments in the instrument panel. The engine control unit constantly checks the sensors to make sure they are operational.

The engine control unit contains monitoring functions to protect the engine in the event of a fault which would otherwise damage it. In the event of a fault, e.g. alarm level for low oil pressure or high coolant temperature, the engine control unit sends a CAN message to a coordinator.

The main task of the coordinator is to pass on data by means of CAN communication from the engine control unit to other control units and signals to gauges and lamps in the instrument panel. The coordinator also has monitoring functions.

The alarm levels for the system have standard values but can be reprogrammed using SDP3 (Scania Diagnos and Programmer 3). When an alarm level is reached, the following happens:

- If the torque reducing function is activated, the quantity of fuel and the engine power are reduced to 70%.
- If the engine shutdown function is activated, the engine is shut down.

Starting and running

Note:

When the engine is started for the first time, carry out the inspection points listed under First start in the inspection schedule. See the Inspection section.

Always check the following before running:

- oil level
- coolant
- fuel level
- electrolyte level in batteries
- state of charge of the batteries
- condition of the drive belt.

Checks before running

Carry out a daily inspection as described in the inspection schedule prior to operation. See the Inspection section.



WARNING!

Block the starting device when working on the engine. If the engine starts unexpectedly, there is a serious risk of injury.

Starting the engine

For environmental reasons the Scania engine has been developed to be started with a low fuel feed. Using unnecessarily large amounts of fuel when starting the engine always results in emissions of unburnt fuel.

- Open the fuel cock if fitted.
- Disengage the engine.
- If the engine has a battery master switch: Switch on the power by means of the battery master switch.
- Start the engine.

If the fuel tank has been run dry or if the engine has not been used for a long time, bleed the fuel system.



WARNING!

Never use starter gas or similar agents to help start the engine. An explosion may occur in the intake manifold with a risk of personal injury.

Only start the engine in a well ventilated area. When the engine is run in an enclosed space, there must be effective devices to extract exhaust gases and crankcase gases.



IMPORTANT!

The starter motor must only be cranked twice for 30 seconds at a time. After that, it must rest for at least 5 minutes before the next attempt to start it.

Starting at low temperatures

Take the local environmental requirements into account. Use a fuel heater and engine heater to avoid starting problems and white smoke.

A low engine speed and a moderate load on a cold engine limits white smoke, gives better combustion and warms up the engine more quickly than warming it up with no load.

Avoid running it longer than necessary at idling speed.

Running

Check instruments and warning lamps at regular intervals.

Engine speed range

600-750 rpm	Low idling speed. Engine idling is controlled by the engine management system (EMS).
Low idling up to 2,300 rpm	The engine operating speed range, depending on power class.
2,300-2,600 rpm	Unsuitable operating speed, but a slightly higher engine speed than the normal maximum operating speed may occur when load is low or negative.
2,600-3,000 rpm	Prohibited engine speed.

Limp home mode

If there is a fault in the normal throttle opening or if CAN communication is interrupted, the following emergency operation option is provided:

A CAN fault or throttle opening fault in an all-speed engine (both signal and idling switch):

- The throttle opening value is 0% and the engine is running at normal idling speed.
- The throttle opening value is 0% and the engine is running at raised idling speed (750 rpm) if this function is activated.

Throttle opening fault, but the idling switch is working:

- The throttle opening value can be increased slowly between 0 and 50% by using the idling switch.

CAN fault:

- The engine is switched off if the shutdown function is activated.

Coolant temperature

Normal coolant temperature during operation is 80-90°C/176-194°F.

Alarm levels are set in the engine control unit. The default setting for the lowest and highest limit values for high coolant temperature are 95°C/203°C and 105°C/221°F respectively.

The high coolant temperature alarm has the following functions:

- Alarm only.
- Alarm and torque reduction at the lowest limit value.
- Alarm at the lowest limit value and engine shutdown at the highest limit value.
- Alarm, torque reduction at the lowest limit value and engine shutdown at the highest limit value.
- Alarm at the lowest limit value and engine shutdown at the highest limit value with the possibility of engine shutdown override control.
- Alarm, torque reduction at the lowest limit value and engine shutdown at the highest limit value, with the possibility of engine shutdown override control.

If run for extended periods under an extremely light load, the engine may have difficulty in maintaining the coolant temperature. At an increased load the coolant temperature rises to the normal value.



IMPORTANT!

An excessively high coolant temperature can damage the engine.

Oil pressure

Information about the normal oil pressure and lowest permitted oil pressure is contained in the section headed Technical Data.

The engine management system has the following alarm levels:

- At an engine speed below 1,000 rpm and an oil pressure below 0.7 bar/10.2 psi.
- At an engine speed above 1,000 rpm and an oil pressure below 2.5 bar/36.3 psi for longer than 3 seconds.

The incorrect oil pressure alarm has the following functions:

- Alarm only.
- Alarm and torque reduction by 30%.
- Alarm and engine shutdown.
- Alarm and engine shutdown override control.

Note:

High oil pressure (above 6 bar/87 psi) is normal when starting a cold engine.

Charging indicator lamp

If the lamp comes on during operation:

- Check and adjust the alternator drive belts as described under the corresponding inspection point. See the Inspection section.

If the charging indicator lamp is still on, this could be due to an alternator fault or a fault in the electrical system.

Engine shutdown

1. Run the engine without a load for a few minutes if it has been run continuously with a heavy load.
2. Switch off the engine.

Note:

The battery voltage must remain on for a few seconds after the engine is switched off so that the control units can store the values and switch to standby mode.

10 prohibited engine shutdowns will cause a torque reduction (70% of fuel quantity). Reset the engine by switching it off correctly once.



IMPORTANT!

There is risk of damage to the turbocharger and post boiling if the engine is switched off without cooling.

The power must not be switched off before the engine has stopped.

Checks after running



WARNING!

Block the starting device when working on the engine. If the engine starts unexpectedly, there is a serious risk of injury.

There is always a risk of sustaining burns when an engine is hot. Particularly hot parts are turbochargers, oil sumps, hot coolant and oil in pipes and hoses.

-
- Check that the power supply has been cut.
 - Fill the fuel tank. Make sure that the filler cap and the area round the filler opening are clean to avoid contamination of the fuel.
 - If there is a risk of freezing, the cooling system must contain enough glycol.
 - If the temperature is below 0°C/32°F: Prepare for the next start by connecting the engine heater (if fitted).



IMPORTANT!

Check the coolant level following the first start. Top up if necessary.

Inspection

The inspection programme covers a number of points that are divided into the following sections:

- Lubrication system
- Cooling system
- Air cleaner
- Electrical system, batteries, etc.
- Miscellaneous



WARNING!

Block the starting device when working on the engine. If the engine starts unexpectedly, there is a serious risk of injury.

The inspection points are divided into intervals as follows:

Daily inspection

Inspection before the first start

Inspection after the first 500 hours of operation

Periodic inspection every 500 hours of operation, performed at 500, 1,000, 1,500, etc.

Periodic inspection every 1,000 hours of operation, performed at 1,000, 2,000, 3,000, etc.

Periodic inspection every 2,000 hours of operation, performed at 2,000, 4,000, 6,000, etc.

Periodic inspection every 6,000 hours of operation, performed at 6,000, 12,000, etc.

Annual maintenance

Maintenance every 5 years

Engines with few hours of operation



IMPORTANT!

On engines with few hours of operation, inspection must be carried out at the interval of annually or every 5 years.

Stand-by generator sets and the like that are not used regularly should be test run and checked in accordance with the manufacturer's instructions.

The following inspection points must be carried out once the engine has been warmed up to operating temperature.

1. Checking oil level.
2. Checking coolant level.
3. Checking vacuum indicator.
4. Checking fuel level.
5. Checking for engine leaks.

Inspection interval

	Daily	First time at		Interval (hours)			At least		
		First start	500	500	1,000	2,000	Annually	Every 5 years	
Lubrication system	X	X							
Checking oil level.									
Changing the oil					X ¹			X	
Cleaning the centrifugal oil cleaner.					X ¹			X	
Renewing the oil filter.				X ¹			X		
Cooling system	X								
Checking coolant level.									
Checking the coolant level monitor.						X		X	
Checking coolant antifreeze or corrosion inhibitor.			X				X	X	
Cleaning the cooling system and changing coolant.						X ¹		X	
Air cleaner	X								
Reading the vacuum indicator.									
Cleaning or renewal of the filter element.							X ¹		X
Renewing the safety cartridge.							X		X
Fuel system	X	X							
Checking fuel level.									
Renewing the fuel filter.							X ¹		
Miscellaneous		X				X		X	
Checking the drive belt.									
Check for leaks.	X						X		
Checking and adjusting valve clearances and injectors.			X				X		

1 More often if required.

Lubrication system

Oil grade

What is Scania LDF?

Scania LDF stands for the Scania Long Drain Field test standard. Approved Scania LDF oils have been carefully selected after extensive testing. The approval is only granted to the highest quality engine oils available on the market.

Recommended oil
Scania Oil LDF
Scania Oil LDF-2
Scania Oil E7

The engine oil must fulfil the following quality requirements:

- ACEA E5/API CI-4
- ACEA E7/API CI-4+ (for fuel with maximum 15 ppm sulphur content (0.0015%))
- For engines not run on low-sulphur fuel, the TBN (Total Base Number) should be at least 12 (ASTM 2896).
- Low ash oils (ACEA E9/API CJ4) are not recommended.

Check with your oil supplier that the oil meets these requirements.

If the engine is used in areas of the world where lubricating oil with ACEA or API classification is not available, the oil grade must be measured in actual operation. In such cases, contact the Scania application department.

Sulphur content in fuel and its effect on oil change interval

- A sulphur content of 0-500 ppm in the fuel gives an oil change interval of up to 500 hours.

Note:

More than 15 ppm sulphur content must only be used where Stage 3A/Tier 3 or less restrictive emission laws apply.

For operation at extremely low outdoor temperatures: Consult your nearest Scania representative on how to avoid starting difficulties.

Viscosity class	Outdoor temperature
SAE 20W-30	-15°C (5°F) - +30°C (86°F)
SAE 30	-10°C (14°F) - +30°C (86°F)
SAE 40	-5°C (23°F) - > +45°C (113°F)
SAE 50	0°C (32°F) - > +45°C (113°F)
SAE 5W-30	< -40°C (-40°F) - +30°C (86°F)
SAE 10W-30	-25°C (-13°F) - +30°C (86°F)
SAE 15W-40	-20°C (-4°F) - > +45°C (113°F)

Oil analysis

To be able to extend the oil change intervals using an oil analysis, Scania LDF oils must be used.

Oil companies can offer analysis of the engine oil.

The following conditions must remain fulfilled when the oil is changed.

- Viscosity at 100°C (212°F): max. $\pm 20\%$ of original value of the fresh oil.
- TBN (in accordance with ASTM D4739): > 3.5
- TBN (in accordance with ASTM D4739): $> \text{TAN}$ (in accordance with ASTM D664)
- Soot (DIN 51452): $< 3\%$

Such analysis measures the oil's TBN (Total Base Number), TAN (Total Acid Number), fuel dilution, water content, viscosity and the quantity of particles and soot in the oil.

The result of a series of analyses is used as the basis for establishing a suitable oil change interval.

If the conditions are changed, a new oil analysis programme must be carried out to establish new change intervals.

Checking oil level

Daily

Checking the oil level with the engine switched off

Note:

Leave the engine off for at least 1 minute before checking the oil level.

1. Remove the oil dipstick 1 and check the oil level. The correct level is between the minimum and maximum marks on the oil dipstick.
2. Top up with oil when the oil level is at or below the lower mark.

Information on the correct oil type is found under the heading Oil grade.

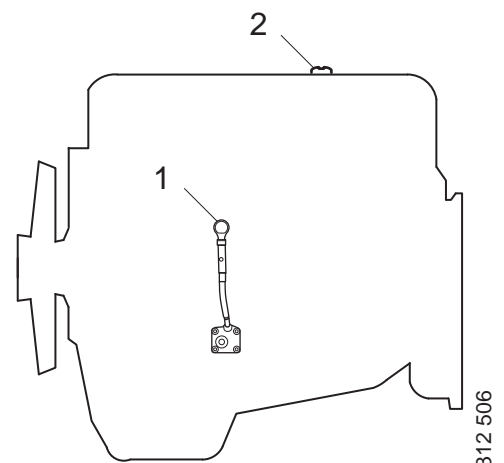

312 506

Changing the oil

Every 500 hours

Note:

Renew the oil filter and clean the centrifugal oil cleaner when changing oil.



WARNING!

Hot oil can cause burns and skin irritation. Wear protective gloves and goggles when changing hot oil.

Make sure that there is no pressure in the lubrication system before starting work on it.

The oil filler cap must always be in place when starting and running the engine to prevent oil being ejected.



Environment

Use a container to avoid spillage. Used oil must be disposed of as specified in national and international law.

Note:

Change oil more often if the engine is subjected to particularly demanding operation, such as a dusty environment, or if deposits in the centrifugal oil cleaner are thicker than 28 mm (1.1 in).

1. Unscrew the oil plug and drain the oil when the engine is hot.
In certain engines the oil is pumped out by means of a bilge pump.
2. Clean the magnet on the oil plug.
3. Refit the oil plug.
4. Top up with oil.
5. Check the level on the oil dipstick.

Maximum angles of inclination during operation

Maximum permissible angles during operation vary, depending on the type of oil sump; see illustration.

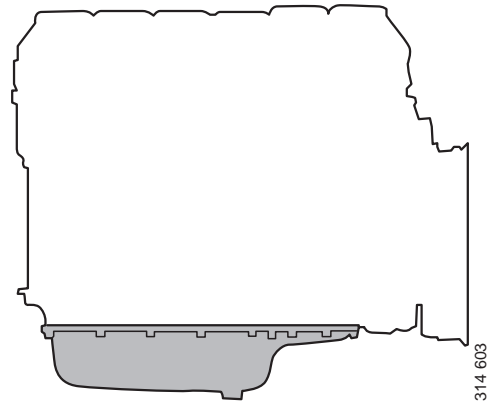

Max. 45 litres (11.9 US gallons)

Min. 39 litres (10.3 US gallons)

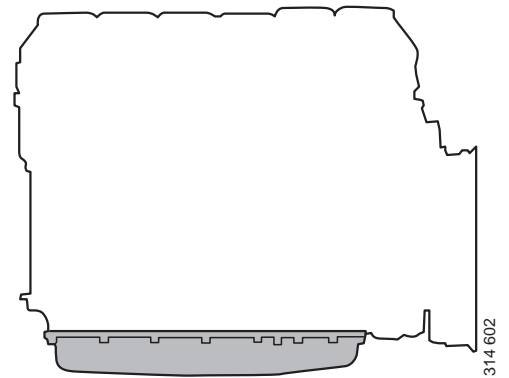

Max. 34 litres (9 US gallons)

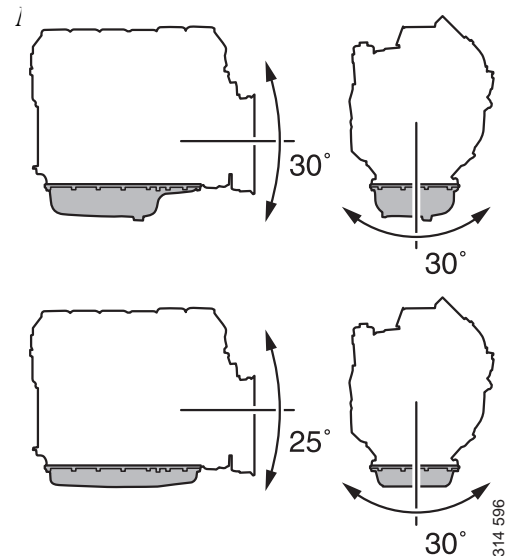

Cleaning the centrifugal oil cleaner

Every 500 hours



WARNING!

The oil may be hot. Carefully remove the cover from the centrifugal oil cleaner.

1. Clean the outside of the cover.
Unscrew the nut and remove the cover.

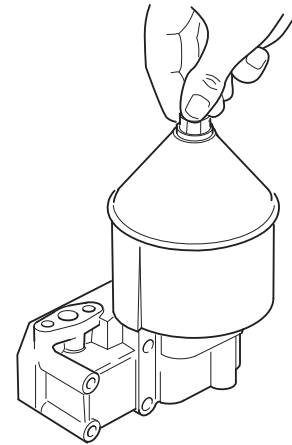

312 501

2. Lift out the rotor.
Wipe off the outside of the rotor.
Unscrew the rotor cover nut about one and a half turns.

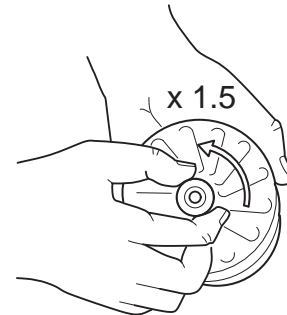

312 500

3. If the rotor nut is jammed: Turn the rotor upside down and fasten the nut in a vice.
Turn the rotor approximately one and a half turns anticlockwise by hand or use an M20 screw as illustrated.

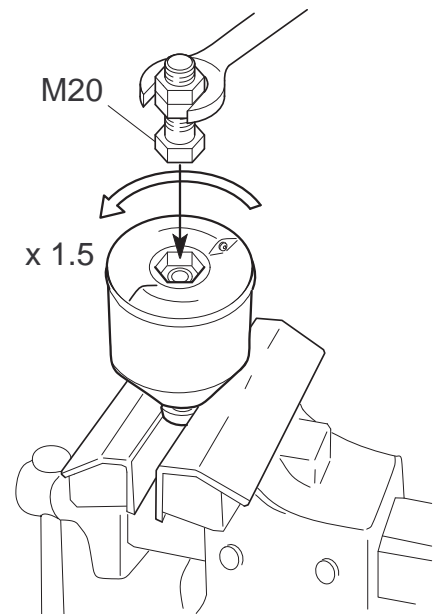

312 517



IMPORTANT!

The rotor must not be put in a vice. This may cause damage resulting in rotor imbalance.

4. Hold the rotor and tap lightly on the rotor nut with a plastic mallet or against the workbench, so that the rotor cover comes loose from the bottom plate.



IMPORTANT!

Never strike on the rotor directly as this may damage the bearings.

5. Remove the strainer from the rotor cover.

If the strainer is stuck, insert a screwdriver between the rotor cover and strainer and carefully prise them apart.

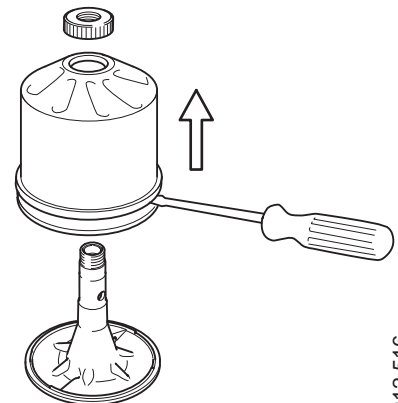

312 516

6. Scrape away the deposits inside the rotor cover with a knife.

If there are no deposits, the centrifugal oil cleaner is not working.

Clean more often if deposits are thicker than 28 mm (1.1 in).

7. Wash the parts in diesel. Inspect the two nozzles on the rotor. Ensure that they are not blocked or damaged. Renew any damaged nozzles.
8. Check the bearings to ensure that they are not damaged.

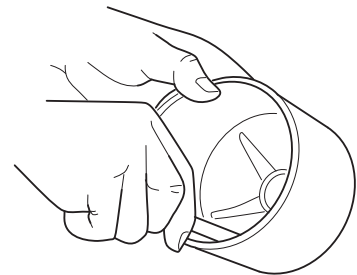

312 515

9. Fit a new O-ring by sliding it over the strainer.
10. Refit the rotor cover. Make sure that the O-ring sits correctly on the inside.
11. Tighten the rotor nut by hand.
12. Check that the shaft is not loose. If it is, it should be locked using thread-locking fluid. Clean carefully with a suitable solvent. Tighten the rotor shaft using the socket with tool number 99 520.

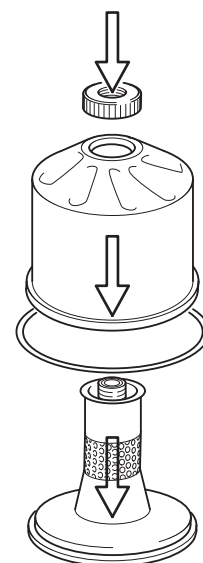

312 514

13. Refit the rotor and screw it by hand to make sure it rotates easily.

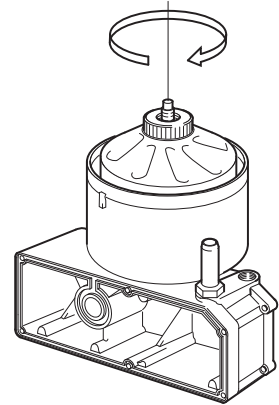

312 513

14. Renew the O-ring on the centrifugal oil cleaner housing cover.

Tighten the lock nut to 15 Nm (11 lbf ft).

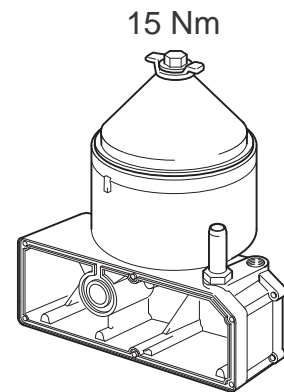

312 512

Renewing the oil filter

Every 500 hours



IMPORTANT!

Only use a Scania oil filter.



IMPORTANT!

Clean the centrifugal oil cleaner when renewing the oil filter.

Otherwise, the oil filter will be blocked and resistance in the filter will increase. If this happens, an overflow valve in the filter retainer opens and lets the oil pass without being filtered.

1. Unscrew the filter cover with a closed tool with hexagon driver, e.g. 36 mm socket 588 475.



IMPORTANT!

Do not use an adjustable spanner or other open tool as there is risk of damaging the filter cover.

2. Lift out the filter housing cover with filter element. The filter housing will drain automatically once the filter has been removed.
3. Detach the old filter from the cover by holding the cover and carefully tapping the entire filter element against something hard. Remember that there will be oil splashes.
4. Fit the new filter and tighten the filter cover to 25 Nm (18 lbf ft).

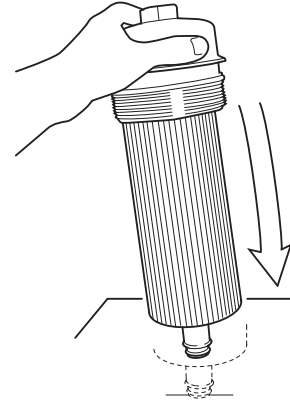

312 503

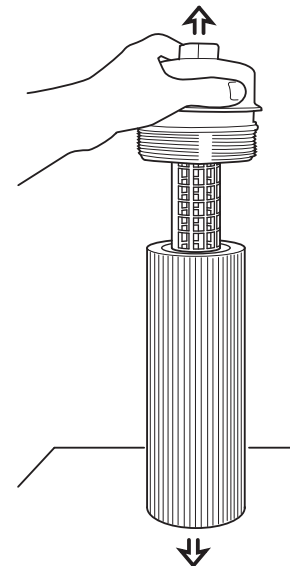

312 502

Cooling system

Coolant



WARNING!

Ethylene glycol can be fatal if ingested and can cause skin irritation and eye damage.

The coolant recommended by Scania is a mixture of water with antifreeze and corrosion inhibitor (ethylene glycol). The coolant has several characteristics which are important for the operation of the cooling system:

- Corrosion inhibitor
- Antifreeze
- Increases the boiling point

The coolant should always contain 35-55% by volume of antifreeze and corrosion inhibitor so that the coolant properties ensure that the coolant works correctly.

Note:

The coolant should be changed when the cooling system is cleaned: every 6,000 hours or at least every 5 years. Refer to Changing coolant.

Coolant's resistance to cold

The following example shows coolant properties with 30 percent by volume of antifreeze and corrosion inhibitor:

- Ice slush starts to form at $-16\text{ }^{\circ}\text{C}$ ($3\text{ }^{\circ}\text{F}$).
- At $-30\text{ }^{\circ}\text{C}$ ($-22\text{ }^{\circ}\text{F}$), there is a risk of cooling system malfunction.
- There is no risk of damage by freezing with a minimum antifreeze and corrosion inhibitor content of 35 percent by volume.

The chart depicts coolant properties at different percents of antifreeze and corrosion inhibitor concentration by volume.

Curve A: Ice formation starts (ice slush)

Curve B: Damage by freezing occurs

Area 1: Safe area

Area 2: Malfunctions may occur (ice slush)

Area 3: Risk of damage by freezing

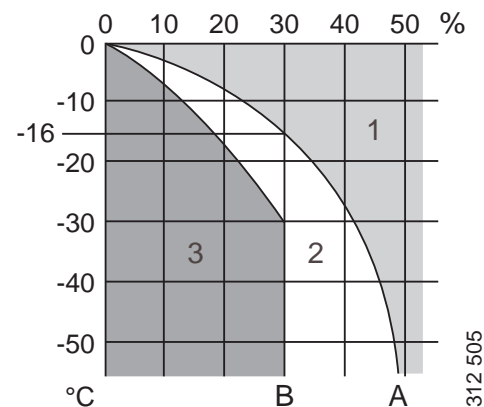

312 505

Antifreeze and corrosion inhibitor concentration table

35% by volume of Scania antifreeze provides sufficient protection against corrosion.

Example:

1. The total volume of the cooling system is 40 litres in this example.
2. The measured concentration of ethylene glycol is 35% by volume (freezing point -21 °C). According to the table there are 14 litres of ethylene glycol in the cooling system.
3. The desired concentration of ethylene glycol is 45% by volume (freezing point -30°C). According to the table, 18 litres of ethylene glycol are required in the cooling system.
4. Since there are already 14 litres in the cooling system, 4 litres of ethylene glycol must be added to the cooling system (18-14=4 litres).

	For calculation			Adequate corrosion protection					Cooling system volume (litres)
Volume of ethylene glycol (%)	20	25	30	35	40	45	50	60	
Ice slush forms (°C)	-6	-9	-12	-21	-24	-30	-38	-50	
Volume of ethylene glycol (litres)	5	6	8	11	12	14	15	18	30
	6	8	10	14	16	18	20	24	40
	8	10	13	18	20	23	25	30	50
	9	12	15	21	24	27	30	36	60
	11	14	18	25	28	32	35	42	70
	12	16	20	28	32	36	40	48	80
	14	18	23	32	36	41	45	54	90
	15	20	25	35	40	45	50	60	100
	17	22	28	39	44	50	55	66	110
	18	24	30	42	48	54	60	72	120
	20	26	33	46	52	59	65	78	130
	21	28	35	49	56	63	70	84	140
	23	30	38	53	60	68	75	90	150
	24	32	40	56	64	72	80	96	160
	26	34	43	60	68	77	85	102	170
	27	36	45	63	72	81	90	108	180
29	38	48	67	76	86	95	114	190	
30	40	50	70	80	90	100	120	200	

Antifreeze and corrosion inhibitor concentration table

35% by volume of Scania antifreeze provides sufficient protection against corrosion.

Example:

1. The total volume of the cooling system is 10.6 US gallons in this example.
2. The measured concentration of ethylene glycol is 35% by volume (freezing point -6 °F). According to the table there are 3.7 US gallons of ethylene glycol in the cooling system.
3. The desired concentration of ethylene glycol is 45% by volume (freezing point -22 °F). According to the table, 4.8 US gallons of ethylene glycol are required in the cooling system.
4. Since the cooling system already contains 3.7 US gallons, fill another 1.1 US gallons of ethylene glycol in the cooling system ($4.8 - 3.7 = 1.1$ US gallons).

Volume of ethylene glycol (%)	For calculation			Adequate corrosion protection					Cooling system volume (US gallons)
	20	25	30	35	40	45	50	60	
Ice slush forms (°F)	21	16	10	-6	-11	-22	-36	-58	
Volume of ethylene glycol (US gallons)	1.3	1.6	2.1	2.9	3.2	3.7	4	4.8	7.9
	1.6	2.1	2.6	3.7	4.2	4.8	5.3	6.3	10.6
	2.1	2.6	3.4	4.8	5.3	6.1	6.6	7.9	13.2
	2.4	3.2	4	5.5	6.3	7.1	7.9	9.5	15.9
	2.9	3.7	4.8	6.6	7.4	8.5	9.2	11.1	18.5
	3.2	4.2	5.3	7.4	8.5	9.5	10.6	12.7	21.1
	3.7	4.8	6.1	8.5	9.5	10.8	11.9	14.3	23.8
	4	5.3	6.6	9.2	10.6	11.9	13.2	15.9	26.4
	4.5	5.8	7.4	10.3	11.6	13.2	14.5	17.4	29.1
	4.8	6.3	7.9	11.1	12.7	14.3	15.9	19	31.7
	5.3	6.9	8.7	12.2	13.7	15.6	17.2	20.6	34.3
	5.5	7.4	9.2	12.9	14.8	16.6	18.5	22.2	37
	6.1	7.9	10	14	15.9	18	19.8	23.8	39.6
	6.3	8.5	10.6	14.8	16.9	19	21.1	25.4	42.3
	6.9	9	11.4	15.9	18	20.3	22.5	26.9	44.9
	7.1	9.5	11.9	16.6	19	21.4	23.8	28.5	47.6
7.7	10	12.7	17.7	20.1	22.7	25.1	30.1	50.2	
7.9	10.6	13.2	18.5	21.1	23.8	26.4	31.7	52.8	

Checking coolant level

Daily

The following instructions apply to Scania expansion tanks. For other types of expansion tanks, follow the manufacturer's instructions.



WARNING!

Never open the coolant filler cap when the engine is hot. Hot coolant and steam may spray out and cause burns.

If the cap has to be opened do it slowly and carefully to release the pressure before removing the cap. Wear gloves as the coolant is still very hot.

1. Open the expansion tank cap and check the coolant level.
 - The right coolant level on a cold engine is even with the lower edge of the filler neck.
 - The right coolant level on a hot engine is approximately 25 mm (1 in) over the lower edge of the filler neck.
2. Top up with coolant as necessary.



IMPORTANT!

It is not advisable to fill large amounts of coolant through the expansion tank. Fill according to the instructions in the section on changing the coolant.



IMPORTANT!

Never fill a large amount of cold coolant in a hot engine. There is great risk of cracks forming in the cylinder block and cylinder heads.



IMPORTANT!

Only pour pre-mixed coolant into the cooling system.

Checking the coolant level monitor

Every 2,000 hours

1. Start the engine.
2. Drain coolant from the expansion tank until the level monitor indicator lamp comes on.

For engines set to switch off when coolant level is too low, the following occurs if the level monitor is working correctly:

- The engine shuts down, a fault code is registered, the indicator lamp comes on and a buzzer may sound.

For engines not set to switch off when coolant level is too low, the following occurs if the level monitor is working correctly:

- The indicator lamp comes on and a buzzer may sound.

3. Fill the system with new coolant as specified under the section Coolant.

Checking antifreeze and corrosion inhibitor

Every 2,000 hours

Note:

Use only pure fresh water that is free from particles, sludge and other impurities.

1. Pour a small amount of coolant into a container and check that the coolant is pure and clear.
2. Change the coolant if it is contaminated or cloudy.
3. Measure the content of antifreeze and corrosion inhibitor with one of the following instruments:

Part No.	Denomination
588 805	Refractometer
588 226	Refractometer

The following rules apply to ethylene glycol-based coolant:

- The antifreeze and corrosion inhibitor content must be minimum 35 percent by volume for corrosion protection to be sufficient.
- An antifreeze and corrosion inhibitor content greater than 55 percent by volume impairs the ability to protect against frost.
- If ice forms in the coolant, there are disruptions initially, but there is no immediate risk of damage. The engine should not be subjected to heavy loads when ice starts to form.

Antifreeze and corrosion inhibitor

Only the product Scania coolant, or other products that are tested to provide proper antifreeze and protection against corrosion for Scania, may be used in Scania engines. Products that do not satisfy the requirements for use in a Scania engine can result in faults in and damage to the cooling system. This can lead to the invalidation of Scania's warranty for faults and damage caused by the use of inappropriate coolant.

The antifreeze and corrosion inhibitor used in Scania engines should be of the ethylene glycol type.

Scania concentrate

Denomination	Contents	Part No.	Volume	Volume (US gallons)
Coolant	Antifreeze and corrosion inhibitor (concentrate)	1 894 323	5 l	1.3 gallons
Coolant	Antifreeze and corrosion inhibitor (concentrate)	1 894 324	20 l	5.3 gallons
Coolant	Antifreeze and corrosion inhibitor (concentrate)	1 894 325	210 l	55 gallons
Coolant	Antifreeze and corrosion inhibitor (concentrate)	1 894 326	1,000 l	264 gallons

Scania Ready Mix

Denomination	Contents	Part No.	Volume	Volume (US gallons)
Coolant	Scania Antifreeze and Corrosion Inhibitor Ready Mix 50/50	1 921 955	5 l	1.3 gallons
Coolant	Scania Antifreeze and Corrosion Inhibitor Ready Mix 50/50	1 921 956	20 l	5.3 gallons
Coolant	Scania Antifreeze and Corrosion Inhibitor Ready Mix 50/50	1 921 957	210 l	55 gallons
Coolant	Scania Antifreeze and Corrosion Inhibitor Ready Mix 50/50	1 896 695	1,000 l	264 gallons

Changing coolant

Every 6,000 hours



Environment

Avoid spillage and use a suitable container. Used coolant must be disposed of as specified in national and international law.



IMPORTANT!

Mix the coolant as specified under the section Coolant.

1. Remove the expansion tank cap.
2. Drain the coolant at the following two spots:
 - Lowest point of the cylinder block.
 - The lowest point of the cooling system.
3. Close the cocks.



IMPORTANT!

When a large amount of coolant needs to be added, it must be pumped in from below to prevent air from getting into the system and causing the coolant pump to overheat and break down.

Filling coolant

1. Connect the hose from unit 588 450 to the engine's drain valve.
2. Ensure that the cooling system bleed pipes are not blocked or damaged. There are bleed pipes from the radiator, engine and expansion tank.
3. Open the expansion tank cap.
4. Fill with coolant using unit 588 450 to pump up to the maximum level of the expansion tank.
5. Disconnect the hose.
6. Set the heating control to maximum heating and start the engine. Idling speed must not exceed 600 rpm. Leave the engine idling for 15 minutes.
7. Stop the engine and top up with coolant to the maximum level through the expansion tank.
8. A small amount of air may still be left in pockets of the cooling system which will disappear when the vehicle is back on the road. This means that it will need some topping up to start with.

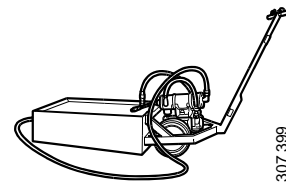

Unit 588 450

Cleaning the cooling system

Every 6,000 hours

Note:

Clean the cooling system more often if necessary.



IMPORTANT!

Do not use caustic soda or other alkaline detergent as this could damage the aluminium.

External: Cleaning the radiator and charge air cooler

1. Check that the radiator and the charge air cooler are not clogged on the air side and that the cooling fins are not damaged.
2. Carefully scrape away any deposits from the radiator cooling fins. Use a paraffin-based engine cleaner if necessary.
3. Carefully straighten bent cooling fins using a steel brush or the like.



WARNING!

To ensure proper handling of cooling system detergent, study the warning text on the package.

Internal: Removing oil and grease

1. Run the engine until it has reached operating temperature and then drain the cooling system.
2. Remove the thermostats.
3. Fill the system with clean, hot water mixed with liquid dishwasher detergent intended for household machines. Concentration 1% (0.1/10 l).
4. Warm up the engine for approximately 20-30 minutes. Remember to switch on the cab heating system, if one is installed.
5. Drain the cooling system.
6. Fill the system with clean, hot water and run the engine for about 20-30 minutes.
7. Drain the water from the cooling system.
8. Refit the thermostats.
9. Fill the cooling system with new coolant following the specification under Coolants earlier in the document.



Environment

Avoid spillage and use a suitable container. Used coolant must be disposed of as specified in national and international law.

Internal: Removing deposits

1. Run the engine until it has reached operating temperature and then drain the cooling system.
2. Remove the thermostats.
3. Fill the system with clean, hot water mixed with some commercially available radiator detergent which is based on sulphamic acid and contains dispersing agents. Follow the manufacturer's instructions for the concentration and cleaning period.
4. Run the engine for the specified time. Remember to switch on the cab heating system, if one is installed.
5. Drain the cooling system.
6. Fill the cooling system with clean, hot water and run the engine for about 20-30 minutes.
7. Drain the water from the cooling system.
8. Refit the thermostats.
9. Fill the system with new coolant following the specification under Coolants earlier in the document.



Environment

Avoid spillage and use a suitable container. Used coolant must be disposed of as specified in national and international law.

Air cleaner

Reading the vacuum indicator

Daily

If the indicator's red plunger is fully visible, renew or clean the air cleaner filter element following the instructions.

Renewing the filter element

Every 2,000 hours

Note:

- Renew the filter element earlier if the indicator shows red.
- There is always a risk that the filter element will be damaged when it is cleaned.
- The filter element must not be washed in water.

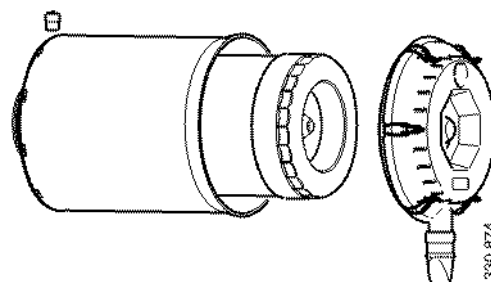

WARNING!

Never start the engine without the air filter as this could cause injury and severe engine damage.

-
1. Remove the cover from the air cleaner.
 2. Renew the filter element.
 3. Carry out a check by inserting an inspection lamp into the element and checking from the outside that there are no holes or cracks in the filter paper.
 4. Assemble the air cleaner.
 5. Reset the vacuum indicator by pressing the button.

Renewing the safety cartridge

Every 2,000 hours



IMPORTANT!

When renewing the safety cartridge, take great care to ensure that no dirt or other impurities get into the engine. Do not remove the safety cartridge unnecessarily.

1. Remove the cover from the air cleaner.
2. Remove the filter element.
3. Remove the safety cartridge.
4. Fit a new, genuine safety cartridge.
5. Renew or clean the filter element.
6. Assemble the air cleaner.

Fuel system

Checking fuel level

Daily

- Check the fuel level and top up with fuel as necessary.

Note:

The fuel system must be bled if the tank is run dry. Refer to Bleeding the fuel system.

Renewing the fuel filter

Every 1,000 hours



Environment

Avoid spillage and use a suitable container. Used fuel must be disposed of as specified in national and international law.

1. Unscrew the filter cover with a closed tool with hexagon driver, e.g. socket 587 637, so as not to damage the filter cover.
2. Lift out the filter cover and filter element. The filter housing will drain automatically. This applies only if the fuel tank is lower than the engine. Otherwise the fuel shut-off cock must be closed first.
3. Undo the removed filter element from the cover by carefully bending it to one side.
4. Renew the O-ring in the cover. Lubricate the O-ring with O-ring grease.
5. Check that the filter housing is drained of fuel. Contaminated fuel may enter the injectors if the drainage does not work.
6. Press a new filter element into the snap fastener in the cover.
7. Fit the filter element and cover in the filter housing. Tighten the cover to 25 Nm (18.4 lbf/ft).
8. Bleed the fuel system after renewing the water separating filter.

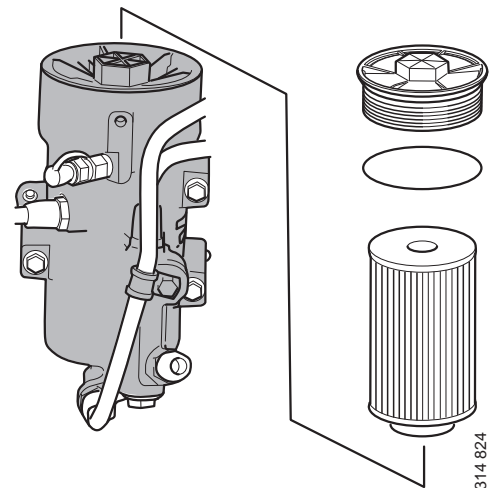

IMPORTANT!

Fit the filter elements in the filter covers before placing them in the fuel filter housings or the filter elements may be damaged.

Renewing the water separating fuel filter

1. Close the shut-off cock in the fuel pipe and position a container under the filter.
2. Open the drain tap in the filter cover and let the fluid run down into the container.
3. Unscrew the filter cover.
4. Unscrew the filter from the filter head.
5. Discard the old filter and use a new filter.
6. Lubricate the O-ring in the filter cover with engine oil.
7. Screw the filter cover onto the new filter by hand. Make sure that the drain tap is fully closed.
8. Lubricate the O-ring on the filter with engine oil.
9. Fill the width of the filter with clean fuel.
10. Screw the filter into position until the O-ring rests against the filter head. Tighten the filter another 1/2-3/4 turn by hand.
11. Open the shut-off cock and check the system for leaks.
12. Bleed the fuel system.

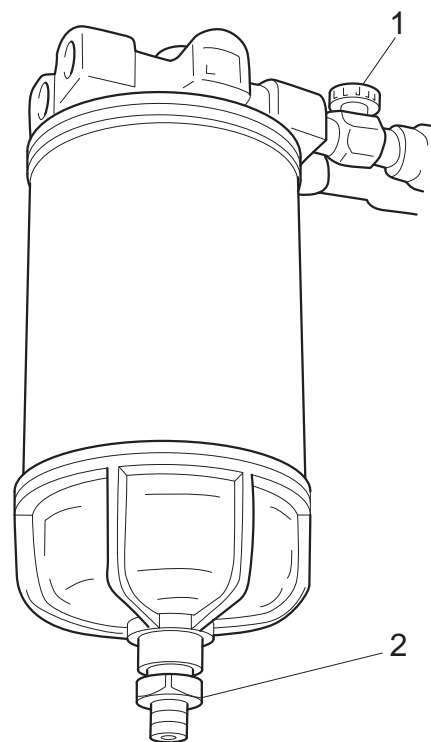

1. Shut-off cock
2. Drain tap

316 148

Bleeding the fuel system

1. Connect a transparent plastic hose to the bleed nipple on fuel filter housing 1. Place the end of the plastic hose in a container with a capacity of at least 3 litres (0.8 US gallons).
2. Open the bleed nipple and pump with the hand pump until fuel comes out of the hose. If the fuel system is empty, it is necessary to pump approximately 100 strokes in order to draw up the fuel. Depending on the installation, a much greater number of pump strokes may be required before fuel comes out.
3. Pump until fuel without air bubbles comes out, approximately 20 strokes.
4. Close the bleed nipple and remove the hose.
5. Transfer the plastic hose to the fuel manifold bleed nipple 2.
6. Open the fuel manifold ventilating valve.
7. Pump with the hand pump until fuel without air bubbles comes out, approximately 50 strokes.
8. Close the bleed nipple on the fuel manifold and remove the plastic hose.
9. Pump approximately 20 strokes with the hand pump until the overflow valve opens. A hissing sound should be heard.
10. Start the engine. The engine should be easy to start.

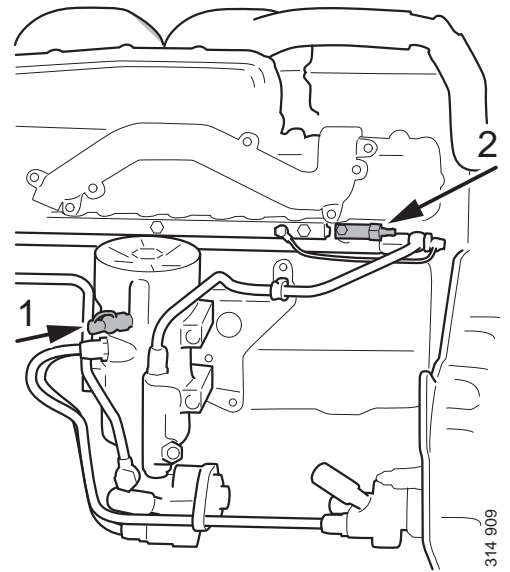

Electrical system

General information on batteries



WARNING!

Do not carry out battery care or store batteries near naked flames or in a place where there is a risk of sparks. When the batteries are charged, oxyhydrogen gas is formed which is flammable and explosive.



WARNING!

Wear gloves and protective goggles when charging and handling batteries. Batteries contain a highly corrosive acid.



WARNING!

Be careful to connect the terminals correctly when connecting the batteries to prevent serious damage to the electrical system. Sparking may occur if the terminals are short-circuited.



Environment

Used batteries must be disposed of as specified in national and international law.

Checking the electrolyte level in batteries

Every 500 hours

- Check that the electrolyte level is at the correct level above the electrodes in all cells (see table).
- Top up with distilled water when necessary.

Battery capacity	Electrolyte level above the plates
140 Ah	20-25 mm (0.8-1 in)
175 Ah	20-25 mm (0.8-1 in)
180 Ah	20-25 mm (0.8-1 in)
220 Ah	30-35 mm (1.2-1.4 in)
225 Ah	30-35 mm (1.2-1.4 in)

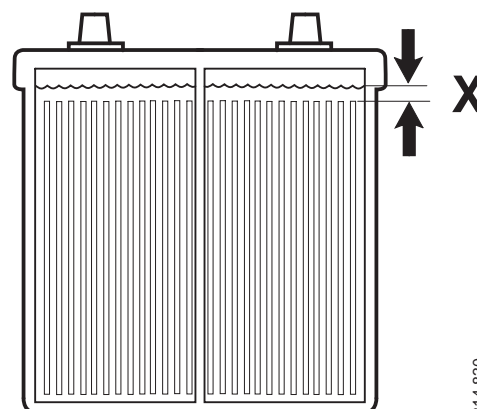

Electrolyte level for low maintenance battery.

Battery capacity	Electrolyte level above the plates
180 Ah	30-35 mm (1.2-1.4 in)

Checking state of charge

Every 1,000 hours

1. Check the density with an acid tester.
In a fully-charged battery it should be:
 - 1.280 at +20°C (68°F)
 - 1.294 at 0°C (32°F)
 - 1.308 at -20°C (-4°F)
2. Charge the battery if the density is lower than 1.20. A discharged battery freezes at -5°C (23°F).



IMPORTANT!

Disconnect the cable terminal prior to charging to prevent control unit damage. Avoid boost charging as this damages the battery over time.

Note:

It is not possible to measure the specific gravity if the battery has recently been topped up with distilled water. It takes several days for water and acid to mix properly.

Cleaning the batteries

Every 1,000 hours

1. Clean batteries, cables and cable terminals.
2. Check that all cable terminals are firmly tightened.
3. Grease the battery terminals and cable terminals with Vaseline.

Renewing the battery

If required

Removal:

1. Disconnect the negative cable (-) from the battery.
2. Disconnect the positive cable (+) from the battery.

Fitting:

1. Connect the positive battery cable (+).
2. Connect the negative battery cable (-).

Checking the coolant level monitor

Every 1,000 hours

1. Start the engine.
2. Drain coolant from the expansion tank until the level monitor indicator lamp comes on.

For engines set to switch off when coolant level is too low, the following occurs if the level monitor is working correctly:

- The engine shuts down, a fault code is registered, the indicator lamp comes on and a buzzer may sound.

For engines not set to switch off when coolant level is too low, the following occurs if the level monitor is working correctly:

- The indicator lamp comes on and a buzzer may sound.

3. Fill the system with new coolant as specified under the section Coolant.

Miscellaneous

Checking the drive belt

Every 1,000 hours:



IMPORTANT!

Refit the drive belt with the same direction of rotation as it had before removal.

Check the drive belt thoroughly, particularly at the idler rollers.

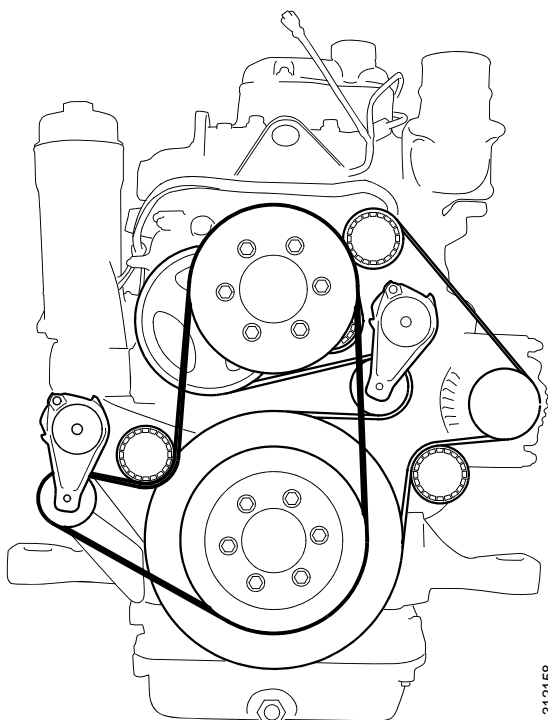

312158

Check the drive belt for cracks.

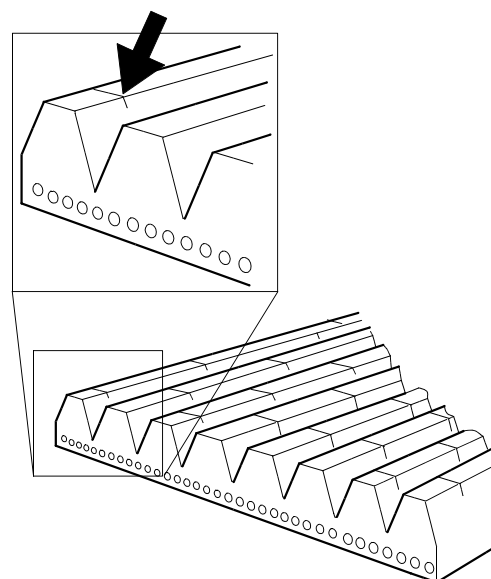

The drive belt must be renewed if it has cracks.

Check drive belt wear.

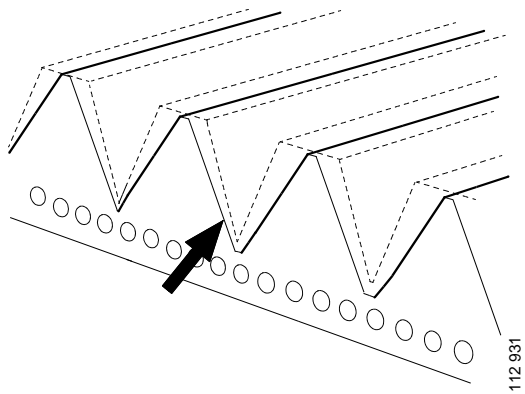

The drive belt is starting to become worn, but can be refitted.

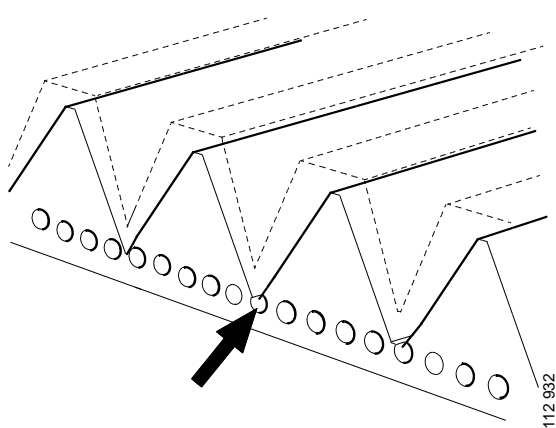

The belt is worn down to the cord. The drive belt must be renewed.

Checking for leaks

Daily

- Start the engine.
- Check for oil, coolant, fuel, air or exhaust leaks.
- Tighten or renew leaking connections. Check the overflow holes which show whether the O-rings between the cylinder liners and crankcase are leaking.
- Check whether the drain hole on the coolant pump is blocked. If there is a leak, renew the seal in the pump or the complete coolant pump.



IMPORTANT!

If serious leakage occurs, contact your nearest Scania workshop.

Checking and adjusting the valve clearance

Every 2,000 hours

Note:

Checking and adjusting valve clearances should also be done after the first 500 hours of operation.

Valve clearances should be adjusted when the engine is cold, at least 30 minutes after running.



WARNING!

Block the starting device when working on the engine. If the engine starts unexpectedly, there is a serious risk of injury.

Readings can be taken from the flywheel through openings in the flywheel housing either from above or below depending on access when fitting.

“TDC up” or “TDC down” is found on the flywheel. Both openings are fitted with a blanking piece on delivery.

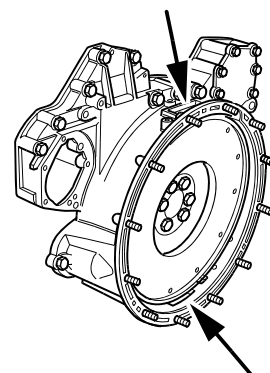

Openings for taking readings on the flywheel housing.

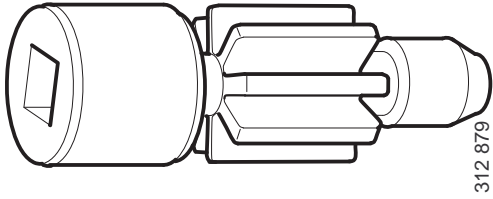

Special tool 99 309 is used when turning from below.

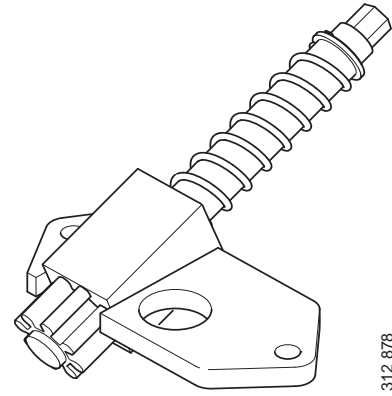

Special tool 99 109 is used when turning from above.

Specifications	
Valve clearance, intake valve	0.45 mm (0.018 in)
Valve clearance, exhaust valve	0.70 mm (0.028 in)

Tightening torques	
Lock nut for valves	35 Nm (26 lbf/ft)
Lock nut for unit injectors	39 Nm (29 lbf/ft)

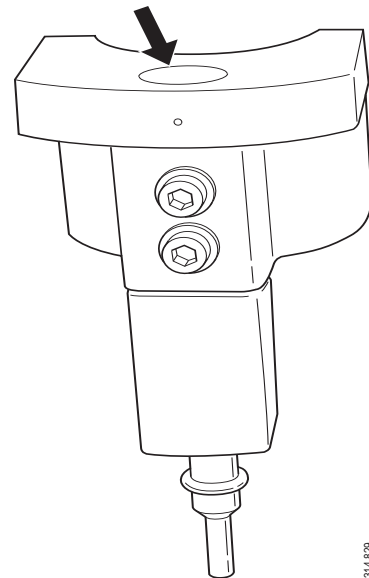

Special tool 99 442 is used to check the height of the unit injectors.

From below	Valve transition	Valve adjustment	Injector	From above
TDC down	1	6	4	TDC up
120/480	5	2	1	300/660
240/600	3	4	5	60/420
TDC down	6	1	3	TDC up
120/480	2	5	6	300/600
240/600	4	3	2	60/420

- Turn the flywheel in the engine's direction of rotation so that TDC down or TDC up is visible in the flywheel housing window.
- Check the valve transition and start adjusting as indicated in the table.

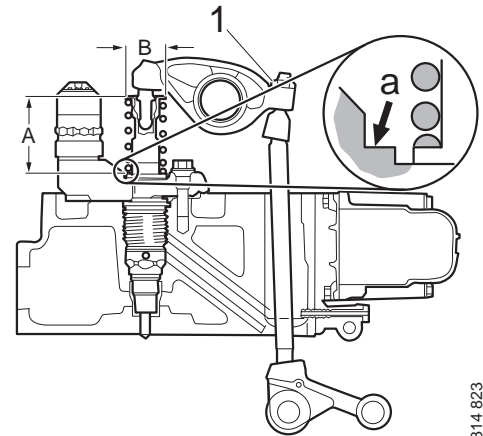

314 823

Checking and adjusting the unit injector

The unit injectors are adjusted using setting tool 99 442 or a digital sliding caliper.

Measurement A=69.9+/-0.1 (2.75 in)

Measurement B=38.8 (1.53 in)

-
1. Fit the setting tool with the metal plate around the unit injector



WARNING!

Be very careful when checking the unit injector if the measurement is outside the setting dimension. The spring is pre-tensioned and can come loose, causing personal injury.

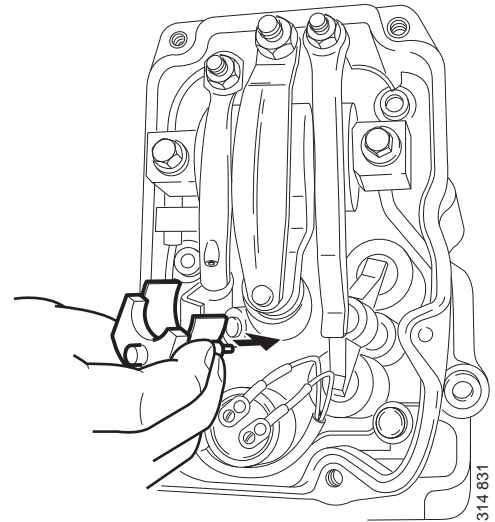

314 831

2. When adjusting, undo the lock nut around the adjusting screw and adjust the unit injector with the adjusting screw 1.

The unit injector is correctly set when the small piston 2 is level with the flat upper surface of the tool. Use a finger to check. Setting dimension is 69.9 +/- 0.1 mm (2.75 in).

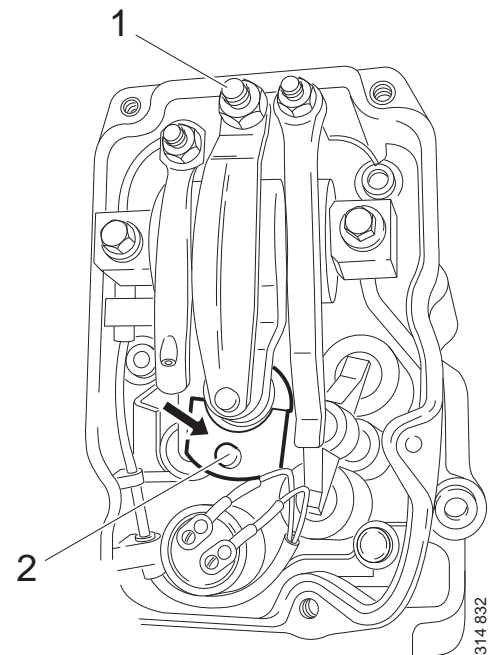

314 832

Preparing the engine for storage

If the engine is not being used for an extended period its cooling system, fuel system and combustion chamber and outside must be protected against rust.

An alternative to preparing the engine for long-term storage is to start the engine and warm it up every 6 months.

Handling the engine

The engine can normally stand idle for up to 6 months without preparation. For longer periods of downtime, the following measures should be taken. These measures provide protection for approximately 4 years.

Preparations for storage:

- Thoroughly clean the engine.
- Run the engine for a specific period using special preservative fuel, oil and coolant.
- Otherwise prepare the engine for storage (filter renewal, lubrication, etc.).

Preservative coolant

If the engine is to be stored with a full cooling system, use coolant containing 50 percent glycol by volume. Glycol without nitrite-based inhibitor should be used. Example: BASF G48 or BASF D542



WARNING!

Ethylene glycol is highly dangerous if imbibed. Avoid contact with the skin.

Preservative fuel

Use diesel mixed with Lubrizol 560H or the equivalent. Mix 1 cm³ (ml)/0.06 in³ Lubrizol 560H in 10 dm³/2.3 US gallons of fuel.



WARNING!

Lubrizol 560H contains aromatic hydrocarbons which are hazardous to health.

- Use spot extractors where there is a danger of vapour build-up.
- Wear protective goggles and gloves when handling the fuel.
- Do not use contaminated clothing.
- If it gets in your eyes: Flush with a gentle jet of water for at least 15 minutes and contact a doctor.
- If it gets on your skin: Wash with soap and water.
- If you inhale it: Fresh air, rest and warmth.
- Store in well-sealed containers in a dry, cool, place out of the reach of children.

Lubrizol is flammable and has a 2A fire rating. The flashpoint is +27°C/81°F. In case of fire: Extinguish with carbon dioxide, powder or foam.

Preservative oil

Suitable preservative oils are supplied by most oil companies. Example: Dinitrol 40 or equivalent.

Preparations for storage



Environment

Use a container to avoid spills when draining the oil and coolant. Dispose of used fluids through an authorised waste disposal contractor.

1. Drain and flush the cooling system. Top up with preservative coolant.
2. Warm up the engine on normal fuel. Stop the engine and drain the oil.
3. Renew the fuel filter.
4. Fill the engine with preservative oil up to the minimum level on the oil dipstick.
5. Mix preservative fuel in a can. Detach the fuel pipe at the feed pump suction line and connect a hose from the can.
6. Detach the fuel pipe at the overflow valve and connect a return hose to the can.
7. Start the engine and run it at about 1,000 rpm for 20-25 minutes.
8. Stop the engine, remove the hoses and connect the normal fuel pipes.
9. Remove the rocker covers and lubricate the valve mechanisms with plenty of preservative oil. Refit the rocker covers.

Note:

Do not remove the injectors.

-
10. Drain the preservative oil from the engine. Fill with new engine oil immediately or when the engine is to be reused.
 11. Drain the coolant if the engine is not to be stored with coolant in the system. Plug and tape all coolant connections if the engine is to be stored without a cooling system.
 12. Air cleaner: Clean or renew the filter element.
 13. Cover air intakes and exhaust pipes.
 14. Alternator and starter motor: Spray with water-repellent anti-corrosive oil, CRC 226, LPS1 or the equivalent.
 15. Spray the outside of bright engine parts, first with penetrating preservative oil such as Dinitrol 25B and then with Dinitrol 112 or the equivalent.

Clearly mark the engine with the storage preparation date, and state that the engine must not be started or cranked.

Batteries

Remove the batteries for trickle charging at the battery charging station. This does not apply to batteries specified as maintenance-free by the manufacturer.

The same applies to short-term storage, even if the engine has not been prepared for storage as above.



WARNING!

Wear gloves and protective goggles when charging and handling batteries. The batteries contain a highly corrosive acid.

Storage

After the preparations, the engine should be stored in a dry and warm place (room temperature).

When the engine is to be taken into operation again

- Remove plugs and tape from coolant connections, air intakes and exhaust pipes.
- Fill the cooling system with coolant. For more information refer to the section headed Inspection.
- Check the oil level in the engine or top up with fresh engine oil.
- Lubricate the valve mechanisms and their pushrods and valve tappets as well as the injector mechanisms with plenty of oil.
- Drain the preservative fuel from the fuel manifold and fuel filter.
- Connect and bleed the fuel system. For more information refer to the section headed Inspection.
- Wash off any preservative oil on the outside using white spirit.

Technical data

General data

Number of cylinders and configuration	6, straight
Working principle	4 stroke engine
Cylinder diameter (mm/in)	130/5.12
Piston stroke (mm/in)	160/6.30
Displacement (dm ³ /in ³)	12.7/775.0
Firing sequence	1 - 5 - 3 - 6 - 2 - 4
Compression ratio	17.3:1
Engine direction of rotation viewed from rear	Anticlockwise
Fan direction of rotation viewed from front	Clockwise
Cooling	Coolant
Valve clearances, cold engine:	
Intake valve (mm/in)	0.45/0.02
Outlet valve (mm/in)	0.70/0.03
Number of teeth on the flywheel	158
Low idling speed (rpm)	500-1,050
Maximum full-load speed (rpm)	2,100
Fuel	Diesel
Approximate weight, without coolant and oil (kg/lb)	1,050/2,315

Lubrication system

Oil volume	See Inspection
Oil cleaning	Centrifugal oil cleaning
Oil cooler	Coolant cooled, full flow
Oil filter	Paper filter from Scania
Interval between oil changes (h)	500
Oil pressure (bar)	
Normal with the engine at operating temperature, operating speed	3-6
Minimum permitted at idling speed	0.7
Crankcase pressure with closed crankcase ventilation (mbar)	-5.4 to 2.0

Injection system

Type	PDE (unit injector)
Control system	EMS
Fuel filter	Paper filter from Scania
Fuel filter with water separator	Paper filter from Scania

Cooling system

Volume, excluding radiator (dm ³ /US gallons)	16/4.2
Coolant temperature (°C/°F)	90-95/194-203
Number of thermostats	1
Thermostat opening temperature (°C/°F)	80/176 and 87/189

Intake system

Permissible pressure drop in the intake system with cleaned or new filter (mbar)	30
Permissible pressure drop in the intake system with blocked (dirty) filter (mbar)	65

Electrical system

Type	1-pin, 24 V, DC
Starter motor, standard equipment	1-pin, 24 V, 5.5 kW
Alternator, standard equipment	1-pin, 28 V, 100 A

Diesel

Composition of the fuel

The composition of the fuel is extremely important for the operation and service life of the engine and injection system. The engine output and exhaust gases are also dependent on the fuel grade.

The requirements and testing standards for the most important characteristics are described in the Workshop manual which can be ordered from Scania dealers or directly from Scania.

The fuel must conform to EU standard EN590.

The table shows some of the key properties.

Property	Requirements
Viscosity at 40°C (104°F)	2.0-4.5 cSt
Density at 15°C (59°F)	0.82-0.86 cSt
Ignitability (CET rating)	minimum 49
Flashpoint	56°C (132°F)

Temperature dependency of the fuel

At temperatures lower than those specified for the fuel, paraffin wax may precipitate from the fuel and block filters and pipes. The engine can then lose power or stop.

The fuel is adapted for use in the specific climate of each country. If a vehicle or an engine is to be operated in a temperature zone with a temperature lower than normal, first identify the temperature properties of that particular fuel.

The properties of the fuel when cold can be improved by adopting one of the following measures before the temperature drops:

- Install an electric fuel heater if this particular fuel is not suitable for the expected temperature and no fuel is available with the correct temperature properties.
- Add 0.5-2% alcohol (isopropanol) to prevent any water in the fuel from freezing and forming plugs of ice. Drain fuel tanks and drain or renew fuel filters regularly.



IMPORTANT!

Mixing kerosene or other paraffins with the fuel is prohibited. The injectors may be damaged.

Mixing petrol with the fuel is prohibited. In the long term petrol can cause wear in the injectors and engine.

Scania Assistance

Wherever you are, you can always get assistance from the Scania service organisation, Scania Assistance, all day, every day of the year.

Always call the contact for your country.

AR	0800 999 722 642	IE	+353 71 9634000
AT	+43 1 256 44 11	IT	+39 0461 996 222
AU	1300 SCANIA 1300 722642	KR	+82 1588 6575
BE	+32 2 264 00 00	LU	+32 226 400 000
BG	+359 886 660001	MA	+34 91 678 92 13
BR	0800 019 42 24	MX	01 800 4SCANIA
CA	+1-800-2-SCANIA	NL	+31 70 4182666
CH	+41 800 55 24 00	NO	+47 223 217 00
CL	188 800 722 642	PL	+48 602 622 465
CZ	+420 225 020 225	PT	+48 91 678 9247
DE	+49 261 887 8888	RO	+40 723 27 27 26
DK	+45 333 270 44	SE	+46 42 100 100
ES	+34 91 678 80 58	SK	+421 903 722 048
FI	+358 10 555 24	TR	+90 212 335 04 40
FR	+33 2 414 132 32	TZ	+255 78 472 2642
GB	0 800 800 660 +44 1274 301260	US	1-800-2-SCANIA
GR	+30 6944 420 410	UY	0800 8351
HU	+36 209 727 197	ZA	0800 005 798 +27 11 661 9823

Other countries: +46 8 52 24 24 24

Note:

Calls will be recorded for training purposes.
