



# ELECTRO - DOCUMENTATION

TYPE OF MACHINE : MOBICAT MC 120 Z US

KLEEMANN SERIES : K007

KLEEMANN MATERIAL NO : M20000111\_01

MANUFACTURED FOR : KLEEMANN GMBH  
MANFRED-WÖRNER-STRASSE 160  
D-73037 GÖPPINGEN

MANUFACTURED BY : TPS GMBH

PHONE-NO. : +49/7161/206-0

PLC-CONTROL TYPE : VIPA SPS-CPU-214-V3.0

FAX-NO. : +49/7161/206-100

LANGUAGE : DEUTSCH/ENGLISH

DATE : 18.Apr.2012

*Neue Bestellnummer  
New order number  
2332673\_00*

			DATE	22.Mär.2012	KLEEMANN GMBH					DECKBLATT/ COVER SHEET	KLEEMANN SERIES	K007	40	+	
			EDITED	JHE	MOBICAT MC 120 Z US						KLEEMANN MATERIAL NO	M20000111_01	CAE-SYSTEM: EPLAN 5.70	PG.	1
MODIFICAT.	DATE	NAME	NORM	DIN	ORIGIN	REP.F.	REP.T.							PG.	19

# Table of contents

TPS\_PST2 / 31.03.2003

Plant	Location	Page	Page designation	Page supplementary field	Date	Editor
A0		1	DECKBLATT/ COVER SHEET		22.Mär.2012	HV
A0		2	INHALTSVERZEICHNIS/ TABLE OF CONTENTS		18.Apr.2012	JHE
A0		3	INHALTSVERZEICHNIS/ TABLE OF CONTENTS		18.Apr.2012	JHE
A0		4	INHALTSVERZEICHNIS/ TABLE OF CONTENTS		18.Apr.2012	JHE
A0		5	INHALTSVERZEICHNIS/ TABLE OF CONTENTS		18.Apr.2012	JHE
A0		6	INHALTSVERZEICHNIS/ TABLE OF CONTENTS		18.Apr.2012	JHE
A0		19	KLEMMENUEBERSICHT/ TERMINAL OVERVIEW		17.Apr.2012	JHE
100		1	EINSPEISUNG/ INCOMING SUPPLY		18.Apr.2012	HV
100		2	RESERVE/ SPARE		17.Apr.2012	JHE
100		3	BELEUCHTUNG UND BANDWAAGE/ ILLUMINATION AND BELT WEIGHER		18.Apr.2012	HV
100		4	ABGAENGE VOR HAUPTSCHALTER/ OUTLETS BEFORE MAIN SWITCH		18.Apr.2012	HV
100		5	STEUERSPANNUNG/ CONTROL VOLTAGE		18.Apr.2012	JHE
100		6	NOT-AUS/ EMERGENCY STOP		18.Apr.2012	JHE
100		7	VERSORGUNG 24V STEUERSPG/ SUPPLY 24V CONTROL VOLTAGE		18.Apr.2012	HV
100		8	BRECHER 1/ CRUSHER 1		18.Apr.2012	HV
100		9	STRG. BRECHER 1/ CONTROL. CRUSHER 1		18.Apr.2012	HV
100		10	MOTOREN/ DRIVES		18.Apr.2012	HV
100		11	MOTOREN/ DRIVES		18.Apr.2012	HV
100		12	MOTOREN/ DRIVES		18.Apr.2012	HV
100		13	MOTOREN/ DRIVES		18.Apr.2012	HV
100		14	AUFGABERINNE 8 - POS. 2/ VIBRATING FEEDER 8 - POS. 2		18.Apr.2012	HV
100		15	TEMPERATURUEBERWACHUNG/ TEMPERATURE CONTROL		18.Apr.2012	HV
100		16	RESERVE/ SPARE		18.Apr.2012	HV
100		17	CPU STEUERUNG/ CPU CONTROL SYSTEM		18.Apr.2012	HV
100		18	ANALOG EINGAENGE/ ANALOG INPUTS		18.Apr.2012	HV
100		19	ANALOG AUSGAENGE/ ANALOG OUTPUTS		18.Apr.2012	HV
100		20	DIGITALE EINGAENGE/ DIGITAL INPUTS		18.Apr.2012	HV
100		21	DIGITALE EINGAENGE/ DIGITAL INPUTS		18.Apr.2012	HV
100		22	DIGITALE AUSGAENGE A 124.0 - A 124.7/ DIGITAL OUTPUTS A 124.0 - A 124.7		18.Apr.2012	HV
100		23	DIGITALE AUSGAENGE A 125.0 - A 125.7/ DIGITAL OUTPUTS A 125.0 - A 125.7		18.Apr.2012	HV

DATE	18.Apr.2012	KLEEMANN GMBH		 	INHALTSVERZEICHNIS/ TABLE OF CONTENTS	KLEEMANN SERIES	K007	= A0	+
EDITED	JHE	MOBICAT MC 120 Z US				KLEEMANN MATERIAL NO	M20000111_01	CAE-SYSTEM: EPLAN 5.70	PG. 2
CONTR.	D. MALLKOWSKY	ORIGIN	REP.F.	REP.T.				PG. 19	
MODIFICAT.	DATE	NAME	NORM	DIN					

# Table of contents

TPS\_PST2 / 31.03.2003

Plant	Location	Page	Page designation	Page supplementary field	Date	Editor
100		24	DIGITALE EINGAENGE E 0.0 - E 0.7/ DIGITAL INPUTS E 0.0 - E 0.7		18.Apr.2012	HV
100		25	DIGITALE EINGAENGE E 1.0 - E 1.7/ DIGITAL INPUTS E 1.0 - E 1.7		18.Apr.2012	HV
100		26	DIGITAL EINGAENGE E 2.0 - E 2.7/ DIGITAL INPUTS E 2.0 - E 2.7		18.Apr.2012	HV
100		27	DIGITAL EINGAENGE E 3.0 - E 3.7/ DIGITAL INPUTS E 3.0 - E 3.7		18.Apr.2012	HV
100		28	DIGITAL EINGAENGE E 4.0 - E 4.7/ DIGITAL INPUTS E 4.0 - E 4.7		18.Apr.2012	HV
100		29	DIGITALE EINGAENGE E 5.0 - E 5.7/ DIGITAL INPUTS E 5.0 - E 5.7		18.Apr.2012	HV
100		30	DIGITALE AUSGAENGE A 6.0 - A 6.7/ DIGITAL OUTPUTS A 6.0 - A 6.7		18.Apr.2012	HV
100		31	DIGITALE AUSGAENGE A 7.0 - A 7.7/ DIGITAL OUTPUTS A 7.0 - A 7.7		18.Apr.2012	HV
100		32	DIGITALE EINGAENGE E 8.0 - E 8.7/ DIGITAL INPUTS E 8.0 - E 8.7		18.Apr.2012	HV
100		33	DIGITALE EINGAENGE E 9.0 - E 9.7/ DIGITAL INPUTS E 9.0 - E 9.7		18.Apr.2012	HV
100		34	DIGITALE AUSGAENGE A 10.0 - A 10.7/ DIGITAL OUTPUTS A 10.0 - A 10.7		18.Apr.2012	HV
100		35	DIGITALE AUSGAENGE A 11.0 - A 11.7/ DIGITAL OUTPUTS A 11.0 - A 11.7		18.Apr.2012	HV
100		36	LICHTSCHRANKE BRECHER/ LIGHT BARRIER CRUSHER		18.Apr.2012	HV
100		37	MOTORUEBERWACHUNG/ MOTOR CONTROLLING		18.Apr.2012	HV
100		38	BETRIEBSINSTRUMENTE/ OPERATIONAL INSTRUMENTS		18.Apr.2012	HV
100		39	BETRIEBSINSTRUMENTE/ OPERATIONAL INSTRUMENTS		18.Apr.2012	HV
100		40	RESERVE/ SPARE		18.Apr.2012	HV
100		41	FUNKFERNSTEUERUNG/ RADIO REMOTE CONTROL		18.Apr.2012	HV
KLE		1	KLEMMENLEISTENUEBERSICHT/ TERMINAL STRIP OVERVIEW		18.Apr.2012	JHE
KLE		2	STECKERUEBERSICHT/ PLUG OVERVIEW		18.Apr.2012	JHE
KLE		10	KLEMMENLEISTE -X0/ TERMINAL STRIP -X0		18.Apr.2012	JHE
KLE		11	KLEMMLEISTE -X1/ TERMINAL STRIP -X1		18.Apr.2012	JHE
KLE		12	KLEMMLEISTE -X1/ TERMINAL STRIP -X1		18.Apr.2012	JHE
KLE		13	KLEMMENLEISTE -X3/ TERMINAL STRIP -X3		18.Apr.2012	JHE
KLE		14	KLEMMLEISTE -X5/ TERMINAL STRIP -X5		18.Apr.2012	JHE
KLE		15	KLEMMLEISTE -X5/ TERMINAL STRIP -X5		18.Apr.2012	JHE
KLE		16	KLEMMLEISTE -X6/ TERMINAL STRIP -X6		18.Apr.2012	JHE
KLE		17	KLEMMENLEISTE -X8/ TERMINAL STRIP -X8		18.Apr.2012	JHE
KLE		18	KLEMMENLEISTE -X00/ TERMINAL STRIP -X00		18.Apr.2012	JHE
KLE		19	KLEMMENLEISTE -X00/ TERMINAL STRIP -X00		18.Apr.2012	JHE

# Table of contents

TPS\_PST2 / 31.03.2003

Plant	Location	Page	Page designation	Page supplementary field	Date	Editor
KLE		20	KLEMMLEISTE -X22/ TERMINAL STRIP -X22		18.Apr.2012	JHE
KLE		21	KLEMMENLEISTE -XB/ TERMINAL STRIP -XB		18.Apr.2012	JHE
KLE		22	KLEMMLEISTE -XF/ TERMINAL STRIP -XF		18.Apr.2012	JHE
KLE		23	KLEMMENLEISTE -XG/ TERMINAL STRIP -XG		18.Apr.2012	JHE
KLE		24	KLEMMENLEISTE -XK/ TERMINAL STRIP -XK		18.Apr.2012	JHE
KLE		25	KLEMMLEISTE -XLS TERMINAL STRIP -XLS		18.Apr.2012	JHE
KLE		26	KLEMMLEISTE -XT/ TERMINAL STRIP -XT		18.Apr.2012	JHE
KLE		27	KLEMMLEISTE -0X0/ TERMINAL STRIP -0X0		18.Apr.2012	JHE
KLE		28	KLEMMLEISTE -0X06/ TERMINAL STRIP -0X06		18.Apr.2012	JHE
KLE		29	KLEMMENLEISTE -0X07/ TERMINAL STRIP -0X07		18.Apr.2012	JHE
KLE		30	KLEMMENLEISTE +M-XG/ TERMINAL STRIP +M-XG		18.Apr.2012	JHE
KLE		31	KLEMMENLEISTE +M-XG/ TERMINAL STRIP +M-XG		18.Apr.2012	JHE
KLE		32	STECKER -XOUT/ PLUG -XOUT		18.Apr.2012	JHE
KLE		33	STECKER -3X2/ PLUG -3X2		18.Apr.2012	JHE
KLE		34	STECKER -4X1/ PLUG -4X1		18.Apr.2012	JHE
KLE		35	STECKER -4X2/ PLUG -4X2		18.Apr.2012	JHE
KLE		36	STECKER +M-XF1 PLUG +M-XF1		18.Apr.2012	JHE
KLE		37	STECKER +M-XS2/ PLUG +M-XS2		18.Apr.2012	JHE
KLE		38	STECKER +M-XS5/ PLUG +M-XS5		18.Apr.2012	JHE
KLE		39	STECKER +M-6X1/ PLUG +M-6X1		18.Apr.2012	JHE
KAB		1	KABELUEBERSICHT/ CABLE SURVEY		18.Apr.2012	JHE
KAB		2	KABELUEBERSICHT/ CABLE SURVEY		18.Apr.2012	JHE
KAB		10	-03W1		18.Apr.2012	JHE
KAB		11	-03W2		18.Apr.2012	JHE
KAB		12	-06W1		18.Apr.2012	JHE
KAB		13	-06W2		18.Apr.2012	JHE
KAB		14	-06W3		18.Apr.2012	JHE
KAB		15	-06W4		18.Apr.2012	JHE
KAB		16	-06W5		18.Apr.2012	JHE
KAB		17	-06W6		18.Apr.2012	JHE

DATE	18.Apr.2012	KLEEMANN GMBH		 	INHALTSVERZEICHNIS/ TABLE OF CONTENTS	KLEEMANN SERIES	K007	= A0	+
EDITED	JHE	MOBICAT MC 120 Z US				KLEEMANN MATERIAL NO	M20000111_01	CAE-SYSTEM: EPLAN 5.70	PG. 4
CONTR.	D. MALLKOWSKY	ORIGIN	REP.F.	REP.T.			PG. 19		
MODIFICAT.	DATE	NAME	NORM	DIN					

# Table of contents

TPS\_PST2 / 31.03.2003

Plant	Location	Page	Page designation	Page supplementary field	Date	Editor
KAB		18	-06W7		18.Apr.2012	JHE
KAB		19	-06W8		18.Apr.2012	JHE
KAB		20	-06W12		18.Apr.2012	JHE
KAB		21	-06W15		18.Apr.2012	JHE
KAB		22	-07W1		18.Apr.2012	JHE
KAB		23	-07W2		18.Apr.2012	JHE
KAB		24	-07W3		18.Apr.2012	JHE
KAB		25	-07W4		18.Apr.2012	JHE
KAB		26	-08W8		18.Apr.2012	JHE
KAB		27	-10W1		18.Apr.2012	JHE
KAB		28	-10W2		18.Apr.2012	JHE
KAB		29	-10W3		18.Apr.2012	JHE
KAB		30	-11W1		18.Apr.2012	JHE
KAB		31	-11W2		18.Apr.2012	JHE
KAB		32	-11W3		18.Apr.2012	JHE
KAB		33	-11W4		18.Apr.2012	JHE
KAB		34	-11W5		18.Apr.2012	JHE
KAB		35	-11W6		18.Apr.2012	JHE
KAB		36	-12W1		18.Apr.2012	JHE
KAB		37	-12W2		18.Apr.2012	JHE
KAB		38	-12W3		18.Apr.2012	JHE
KAB		39	-12W4		18.Apr.2012	JHE
KAB		40	-12W5		18.Apr.2012	JHE
KAB		41	-13W1		18.Apr.2012	JHE
KAB		42	-13W2		18.Apr.2012	JHE
KAB		43	-13W3		18.Apr.2012	JHE
KAB		44	-14W1		18.Apr.2012	JHE
KAB		45	-14W2		18.Apr.2012	JHE
KAB		46	-14W3		18.Apr.2012	JHE
KAB		47	-14W4		18.Apr.2012	JHE

DATE	18.Apr.2012	KLEEMANN GMBH		 	INHALTSVERZEICHNIS/ TABLE OF CONTENTS	KLEEMANN SERIES	K007	= A0	+
EDITED	JHE	MOBICAT MC 120 Z US				KLEEMANN MATERIAL NO	M20000111_01	CAE-SYSTEM: EPLAN 5.70	PG. 5
CONTR.	D. MALLKOWSKY	ORIGIN	REP.F.	REP.T.			PG. 19		
MODIFICAT.	DATE	NAME	NORM	DIN					

# Table of contents

TPS\_PST2 / 31.03.2003

Plant	Location	Page	Page designation	Page supplementary field	Date	Editor
KAB		48	-36W1		18.Apr.2012	JHE
KAB		49	-36W2		18.Apr.2012	JHE
KAB		50	-37W1		18.Apr.2012	JHE
KAB		51	-37W2		18.Apr.2012	JHE
KAB		52	-41W1		18.Apr.2012	JHE
KAB		53	-41W2		18.Apr.2012	JHE
KAB		54	-41W3		18.Apr.2012	JHE
KAB		55	-41W4		18.Apr.2012	JHE
KAB		56	-41W5		18.Apr.2012	JHE
STK		1	STUECKLISTE		18.Apr.2012	JHE
STK		2	STUECKLISTE		18.Apr.2012	JHE
STK		3	STUECKLISTE		18.Apr.2012	JHE
STK		4	STUECKLISTE		18.Apr.2012	JHE
STK		5	STUECKLISTE		18.Apr.2012	JHE
STK		6	STUECKLISTE		18.Apr.2012	JHE
STK		7	PART'S LIST		18.Apr.2012	JHE
STK		8	PART'S LIST		18.Apr.2012	JHE
STK		9	PART'S LIST		18.Apr.2012	JHE
STK		10	PART'S LIST		18.Apr.2012	JHE
STK		11	PART'S LIST		18.Apr.2012	JHE
STK		12	PART'S LIST		18.Apr.2012	JHE

# KLEMMLEISTENBEZEICHNUNG/ TERMINAL STRIP DESIGNATION

# STECKERBEZEICHNUNG/ PLUG DESIGNATION

-0X0 = KLEMMLEISTE -0X0/  
TERMINAL STRIP -0X0

-0X06 =KLEMMLEISTE -0X06/  
TERMINAL STRIP -0X06

-0X07 = KLEMMENLEISTE -0X07/  
TERMINAL STRIP -0X07

-X00 =KLEMMENLEISTE -X00/  
TERMINAL STRIP -X00

-X0 =KLEMMENLEISTE -X0/  
TERMINAL STRIP -X0

-X1 = KLEMMLEISTE -X1/  
TERMINAL STRIP -X1

-X3 =KLEMMENLEISTE -X3/  
TERMINAL STRIP -X3

-X5 = KLEMMLEISTE -X5/  
TERMINAL STRIP -X5

-X6 = KLEMMLEISTE -X6/  
TERMINAL STRIP -X6

-X8 = KLEMMENLEISTE -X8/  
TERMINAL STRIP -X8

-X22 = KLEMMLEISTE -X22/  
TERMINAL STRIP -X22

-XB = KLEMMENLEISTE -XB/  
TERMINAL STRIP -XB

-XF = KLEMMLEISTE -XF/  
TERMINAL STRIP -XF

-XG = KLEMMENLEISTE -XG/  
TERMINAL STRIP -XG

-XK = KLEMMENLEISTE -XK/  
TERMINAL STRIP -XK

-XLS = KLEMMLEISTE -XLS  
TERMINAL STRIP -XLS

-XT = KLEMMLEISTE -XT/  
TERMINAL STRIP -XT

+M-XG = KLEMMENLEISTE +M-XG/  
TERMINAL STRIP +M-XG

-XOUT = STECKER -XOUT/  
PLUG -XOUT

-3X2 = STECKER -3X2/  
PLUG -3X2

-4X1 = STECKER -4X1/  
PLUG -4X1

-4X2 = STECKER -4X2/  
PLUG -4X2

+M-XF1 = STECKER +M-XF1  
PLUG +M-XF1

+M-6X1 = STECKER +M-6X1/  
PLUG +M-6X1

+M-XS2 = STECKER +M-XS2/  
PLUG +M-XS2

+M-XS5 = STECKER +M-XS5/  
PLUG +M-XS5

DATE		17.Apr.2012		KLEEMANN GMBH		 	KLEMMENUEBERSICHT/ TERMINAL OVERVIEW		KLEEMANN SERIES		K007		= A0		+	
EDITED		JHE		MOBICAT MC 120 Z US					KLEEMANN MATERIAL NO		M20000111_01		CAE-SYSTEM: EPLAN 5.70		PG. 19	
MODIFICAT.	DATE	NAME	NORM	DIN	ORIGIN	REP.F.	REP.T.							PG. 19		

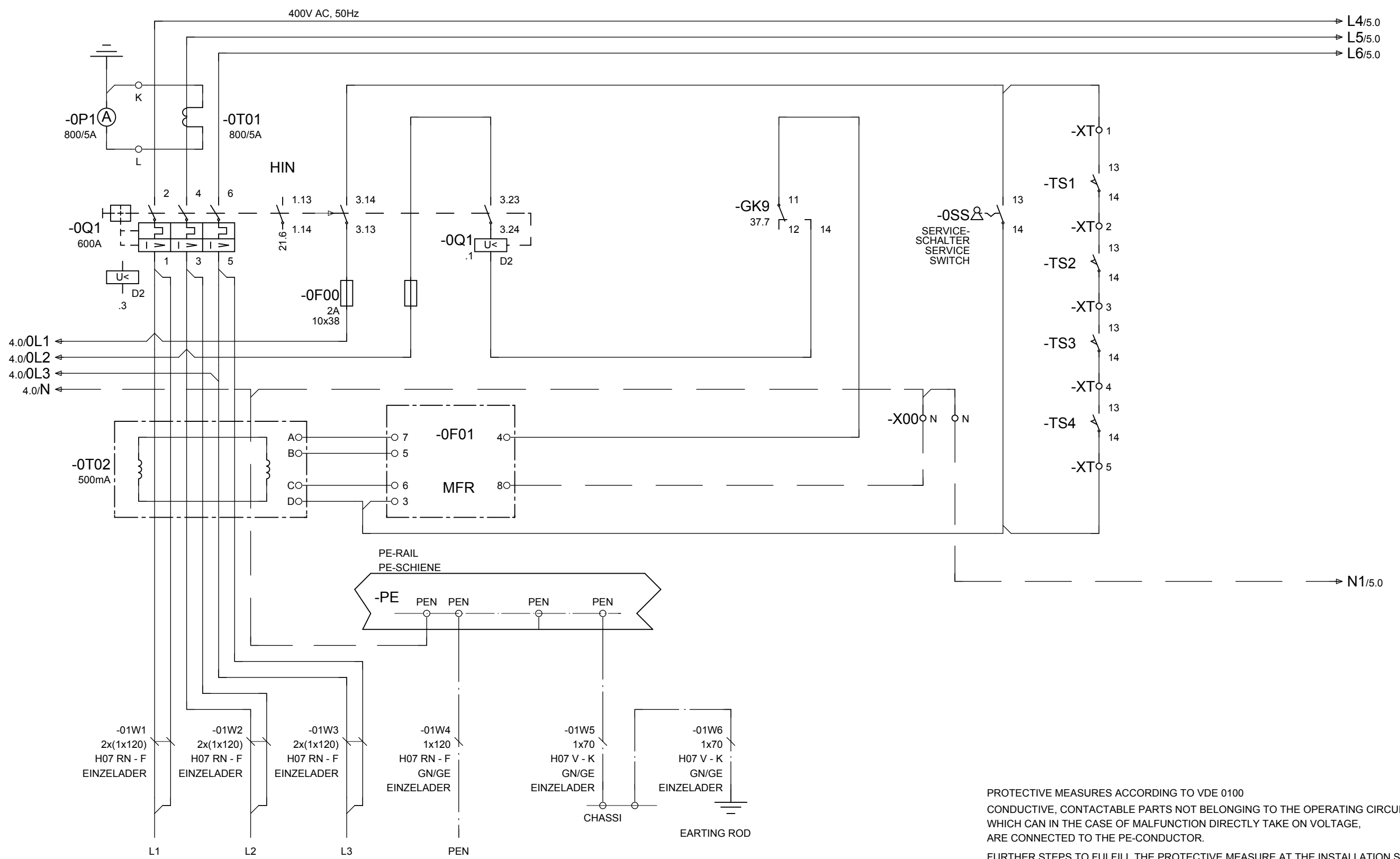

INCOMING SUPPLY 3X400V/PE/50Hz MAIN  
 BACK-UP FUSE 800A  
 POWER SUPPLY FROM SWITCH CUPBOARD  
 EINSPEISUNG 3X400V/PE/50Hz NETZ  
 VORSICHERUNG 800A  
 ENERGIEVERSORGUNG VON SCHALTSCHRANK

TOTAL FAULT  
 CURRENT PROTECTION  
 FI-SCHUTZ  
 GESAMT

PROTECTIVE MEASURES ACCORDING TO VDE 0100  
 CONDUCTIVE, CONTACTABLE PARTS NOT BELONGING TO THE OPERATING CIRCUIT,  
 WHICH CAN IN THE CASE OF MALFUNCTION DIRECTLY TAKE ON VOLTAGE,  
 ARE CONNECTED TO THE PE-CONDUCTOR.  
 FURTHER STEPS TO FULFILL THE PROTECTIVE MEASURE AT THE INSTALLATION SITE,  
 HAVE TO BE CARRIED OUT BY CUSTOMER

SCHUTZMASSNAHME NACH VDE 0100  
 NICHT ZUM BETRIEBSSTROMKREIS GEGHÖRENDE, LEITFAEHIGE BERUEHRBARE TEILE  
 DIE IM FEHLERFALL UNMITTELBAR SPANNUNG ANNEHMEN KOENNEN, SIND MIT DEM  
 PE-LEITER VERBUNDEN.  
 WEITERE MASSNAHMEN ZUR ERFUELLUNG DER SCHUTZMASSNAHME AM AUFSTELLUNGSORT  
 BAUSEITS DURCHFUEHREN

=A0/19

DATE	18.Apr.2012	KLEEMANN GMBH			EINSPEISUNG/ INCOMING SUPPLY	KLEEMANN SERIES	K007	= 100	+
EDITED	JHE	MOBICAT MC 120 Z US				KLEEMANN MATERIAL NO	M20000111_01	CAE-SYSTEM: EPLAN 5.70	PG. 1
CONTR.	D. MALLKOWSKY	ORIGIN	REP.F.	REP.T.			PG. 41		



0

1

2

3

4

5

6

7

8

9

1

3

DATE	17.Apr.2012
EDITED	JHE
CONTR.	D. MALLKOWSKY

KLEEMANN GMBH
MOBICAT MC 120 Z US



RESERVE/ SPARE
-------------------

KLEEMANN SERIES	K007
KLEEMANN MATERIAL NO	M20000111_01

= 100
CAE-SYSTEM: EPLAN 5.70

+	PG. 2
	PG. 41

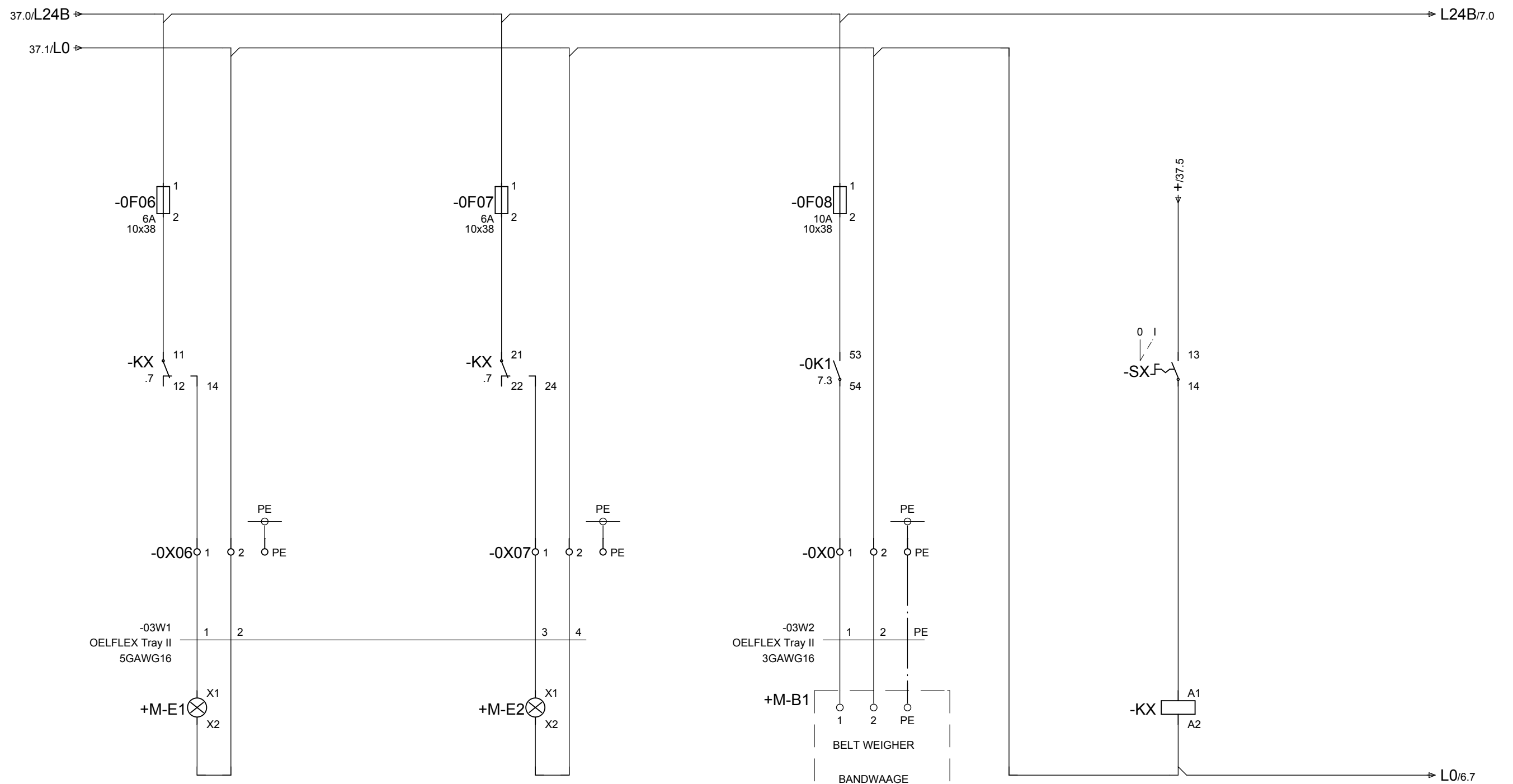

WAGO 788-312  
 14 → 12.1  
 11 → 12.1  
 24 → 22.3  
 21 → 22.3

ILLUMINATION 1

ILLUMINATION 2

BELT WEIGHER

BELEUCHTUNG 1

BELEUCHTUNG 2

BANDWAAGE

DATE	18.Apr.2012	KLEEMANN GMBH				BELEUCHTUNG UND BANDWAAGE/ ILLUMINATION AND BELT WEIGHER	KLEEMANN SERIES	K007	= 100	+
EDITED	JHE	MOBICAT MC 120 Z US					KLEEMANN MATERIAL NO	M20000111_01	CAE-SYSTEM: EPLAN 5.70	PG.
CONTR.	D. MALLKOWSKY	ORIGIN	REP.F.	REP.T.					PG.	41



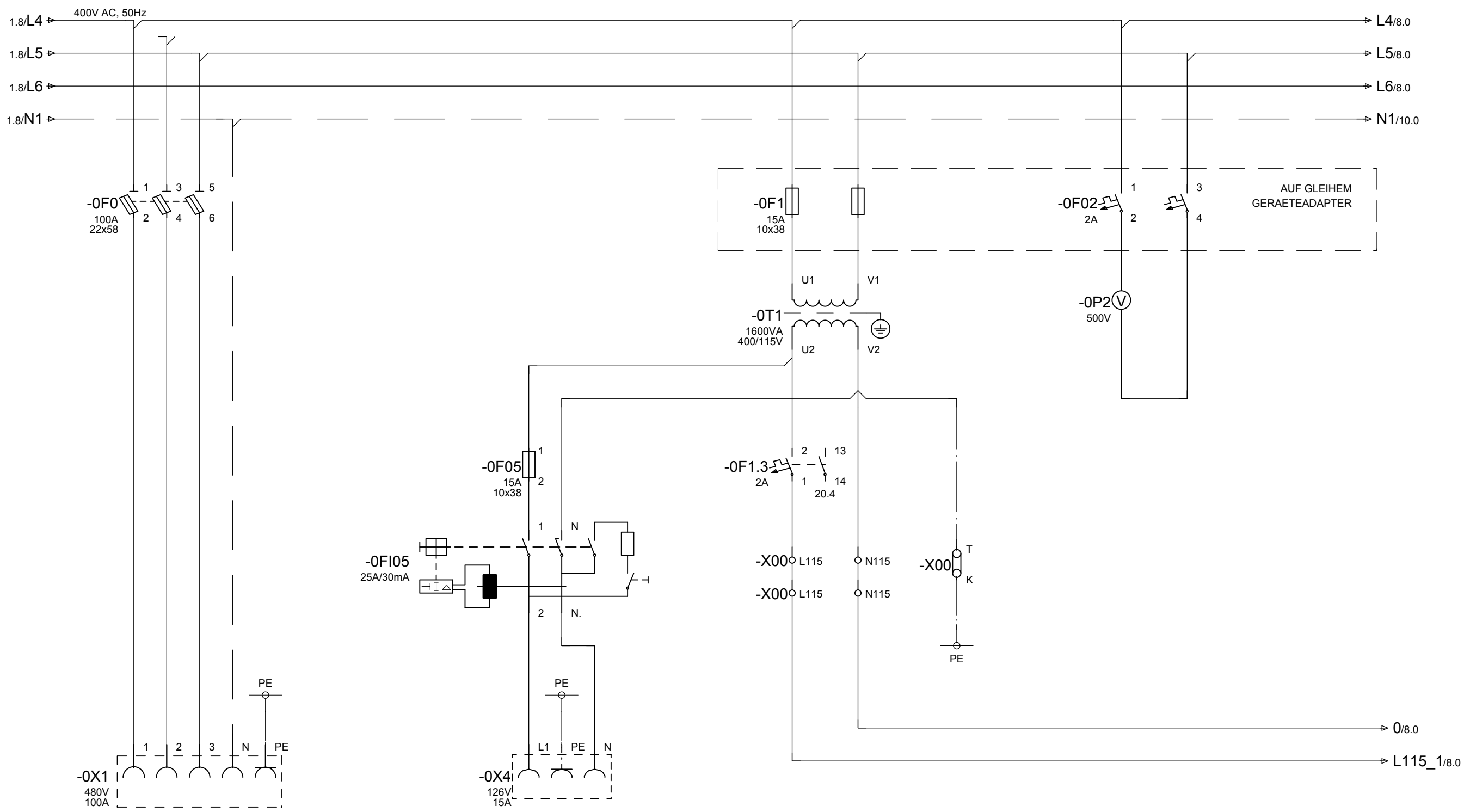

POWER SOCKET 100A  
KRAFTSTECKDOSE 100A

SOCKET 15A/115V  
STECKDOSE 15A/115V

DATE	18.Apr.2012	KLEEMANN GMBH			STEUERSpannung/ CONTROL VOLTAGE	KLEEMANN SERIES	K007	= 100	+
EDITED	JHE	MOBICAT MC 120 Z US				KLEEMANN MATERIAL NO	M20000111_01	CAE-SYSTEM: EPLAN 5.70	PG. 5
CONTR.	D. MALLKOWSKY	ORIGIN	REP.F.	REP.T.				PG. 41	

7.4/L24VN → L24VN/8.5

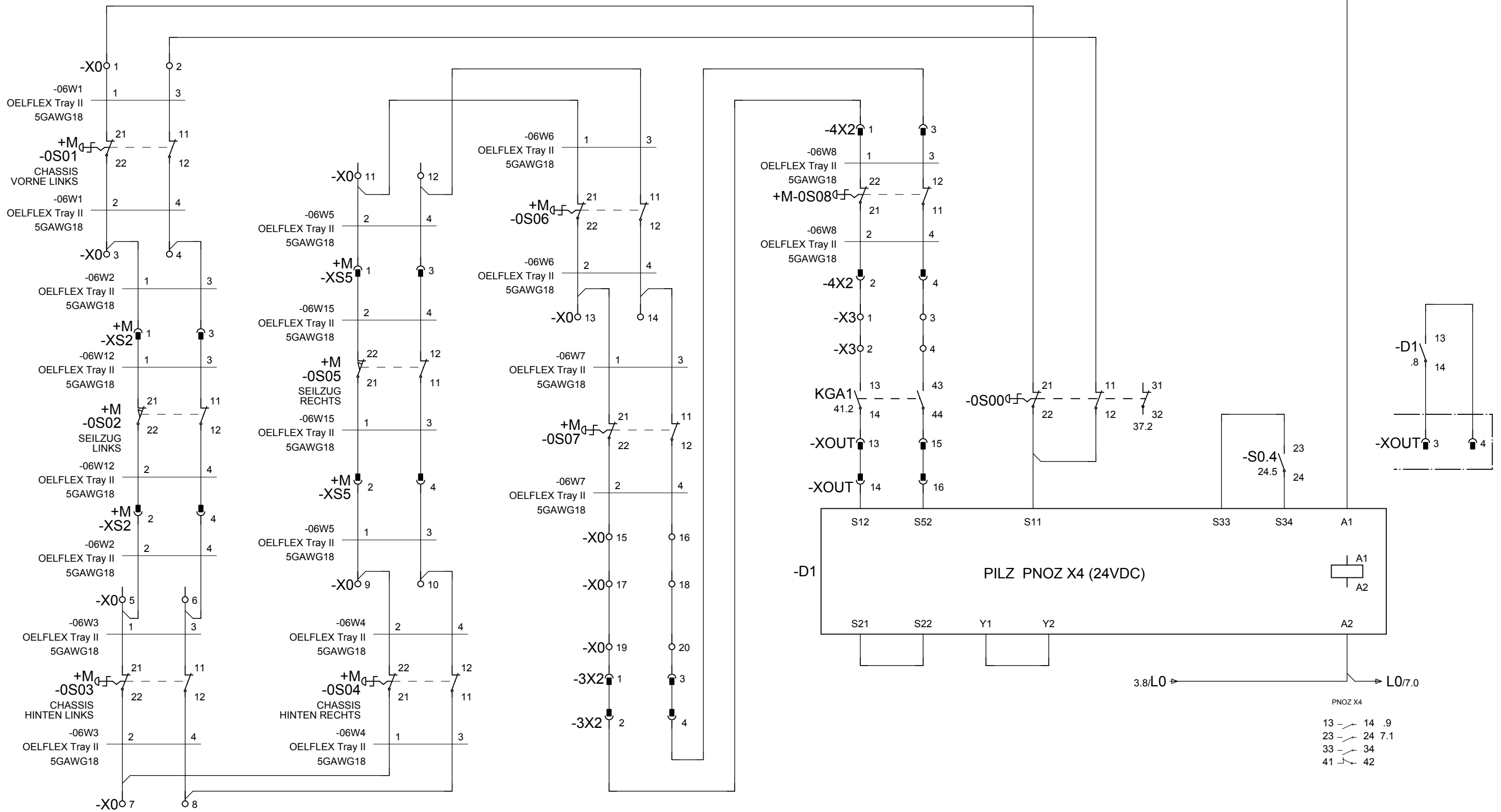

E-STOP PUSH-BUTTON

E-STOP PUSH-BUTTON

EMERGENCY STOP SWITCHGEAR

NOT-AUS TASTER

NOT-AUS TASTER

NOT-AUS SCHALTGERAET

3.8/L0 → L0/7.0

PNOZ X4  
 13 → 14 .9  
 23 → 24 7.1  
 33 → 34  
 41 → 42

DATE		18.Apr.2012		KLEEMANN GMBH			NOT-AUS/ EMERGENCY STOP		KLEEMANN SERIES		K007		= 100		+	
EDITED		JHE		MOBICAT MC 120 Z US			KLEEMANN MATERIAL NO		M20000111_01		CAE-SYSTEM: EPLAN 5.70		PG.		6	
CONTR.		D. MALLKOWSKY		ORIGIN		REP.F.		REP.T.				PG.		41		

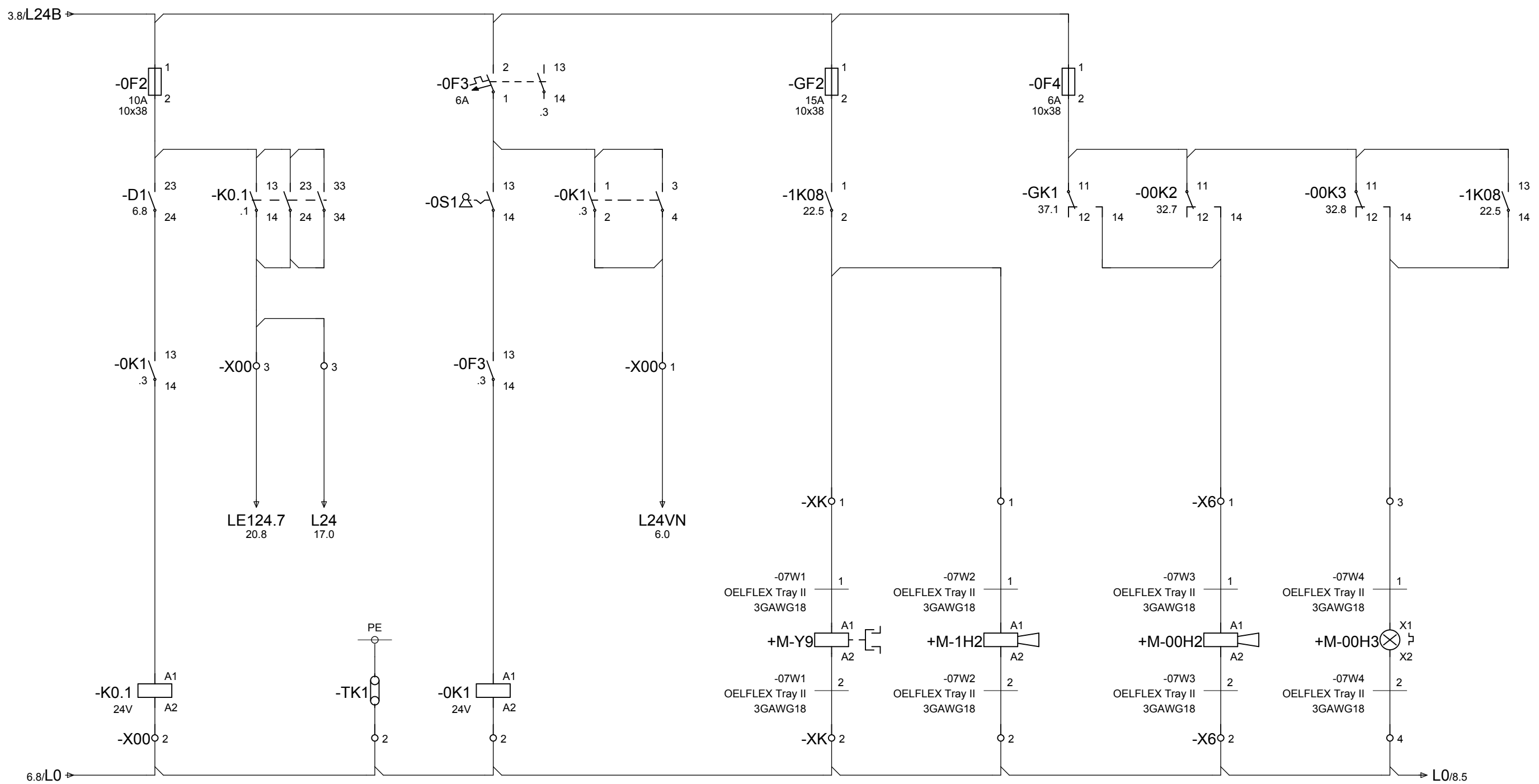

SIE 3RH11 40-2BB40  
 13 → 14 .2  
 23 → 24 .2  
 33 → 34 .2  
 43 → 44

SUPPLY 24V  
 AFTER EMERGENCY STOP  
 VERSORGUNG 24V  
 NACH NOT-AUS

SIE 3RT10 16-2BB41  
 3RH19 11-2FA22  
 1 → 2 .4  
 3 → 4 .4  
 5 → 6 21.7  
 13 → 14 .1  
 53 → 54 3.5  
 61 → 62  
 71 → 72  
 83 → 84

CONTROL VOLTAGE  
 ON  
 STEUERSPANNUNG  
 EIN

COUPLING  
 KUPPLUNG

RUN WARNING  
 FAHRWARNUNG

HOOTER  
 HUPE

FLASHING LIGHT  
 BLINKLICHT

DATE	18.Apr.2012	KLEEMANN GMBH			VERSORGUNG 24V STEUERSPG/ SUPPLY 24V CONTROL VOLTAGE	KLEEMANN SERIES	K007	= 100	+
EDITED	JHE	MOBICAT MC 120 Z US				KLEEMANN MATERIAL NO	M20000111_01	CAE-SYSTEM: EPLAN 5.70	PG. 7
CONTR.	D. MALLKOWSKY	ORIGIN	REP.F.	REP.T.			PG. 41		

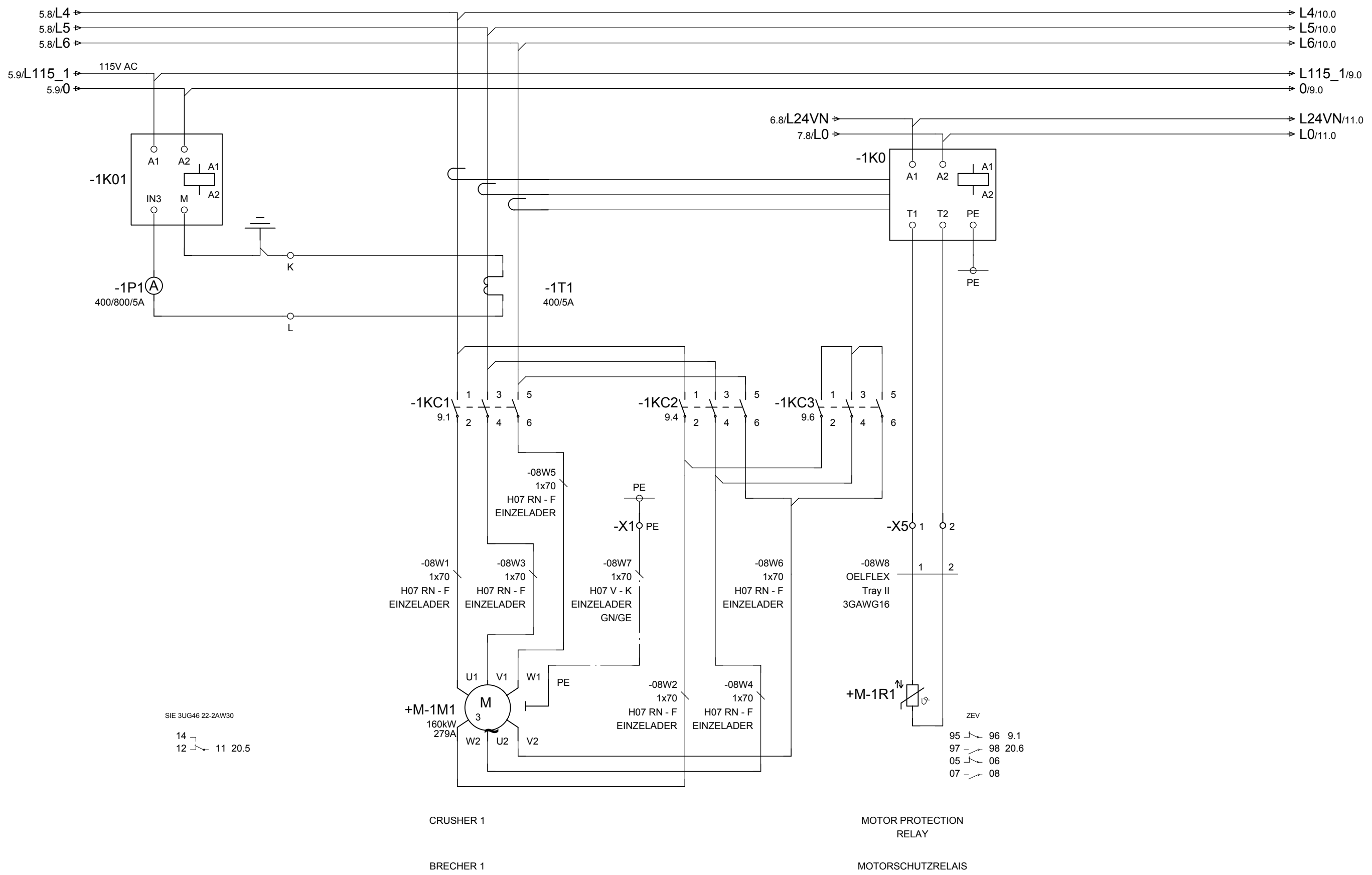

DATE	18.Apr.2012	KLEEMANN GMBH		<b>Kleemann</b>	BRECHER 1/ CRUSHER 1	KLEEMANN SERIES	K007	= 100	+
EDITED	JHE	MOBICAT MC 120 Z US				KLEEMANN MATERIAL NO	M20000111_01	CAE-SYSTEM: EPLAN 5.70	PG. 8
CONTR.	D. MALLKOWSKY	ORIGIN	REP.F.	REP.T.				PG. 41	
MODIFICAT.	DATE	NAME	NORM	DIN					

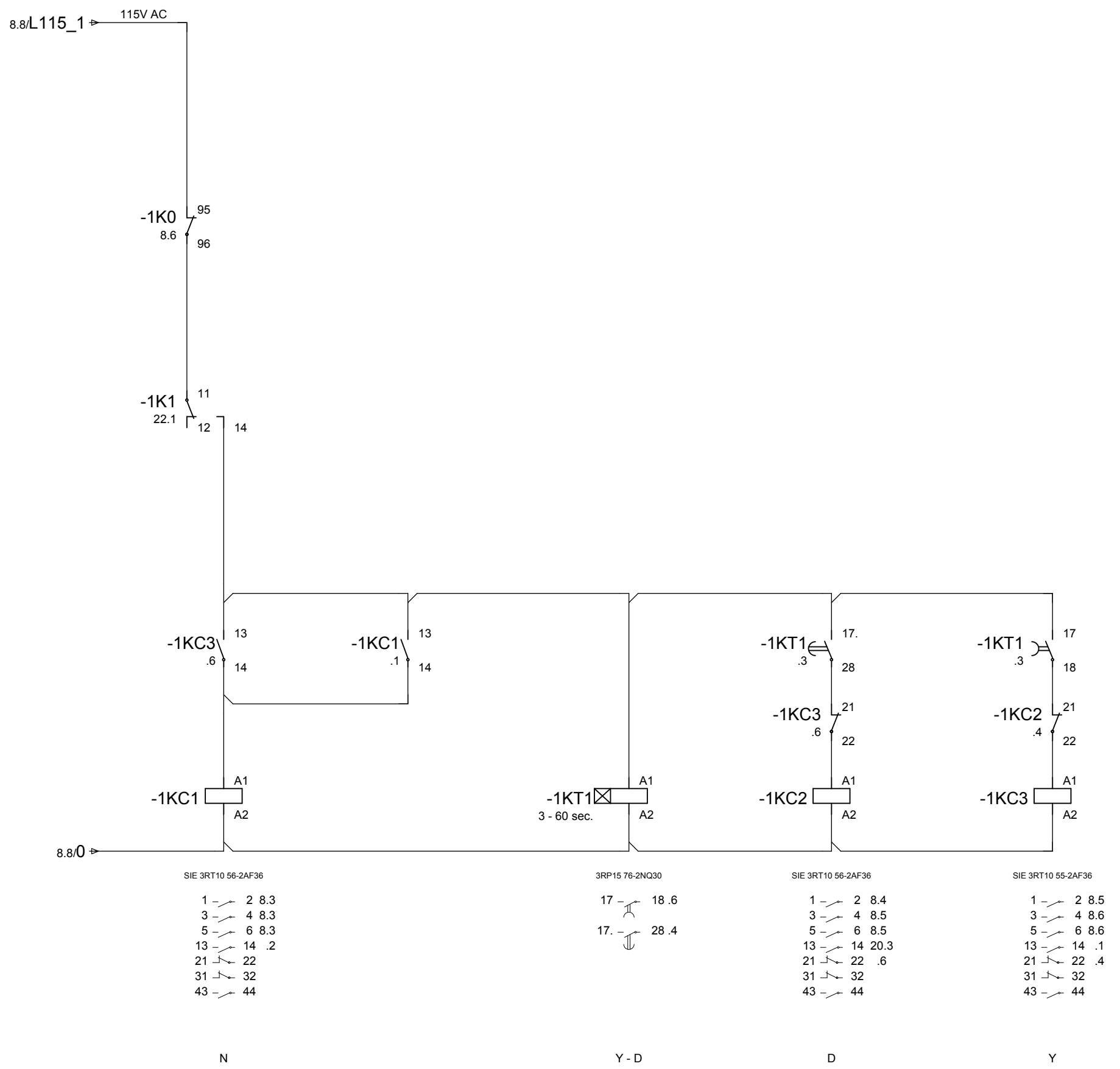

DATE		18.Apr.2012		KLEEMANN GMBH		STRG. BRECHER 1/ CONTROL. CRUSHER 1		KLEEMANN SERIES		K007		= 100		+	
EDITED		JHE		MOBICAT MC 120 Z US		WIRTGEN GROUP		KLEEMANN		M20000111_01		CAE-SYSTEM: EPLAN 5.70		PG. 9	
CONTR.		D. MALLKOWSKY		ORIGIN		REP.F.		REP.T.		MATERIAL NO		PG.		41	
MODIFICAT.	DATE	NAME	NORM	DIN	ORIGIN	REP.F.	REP.T.								





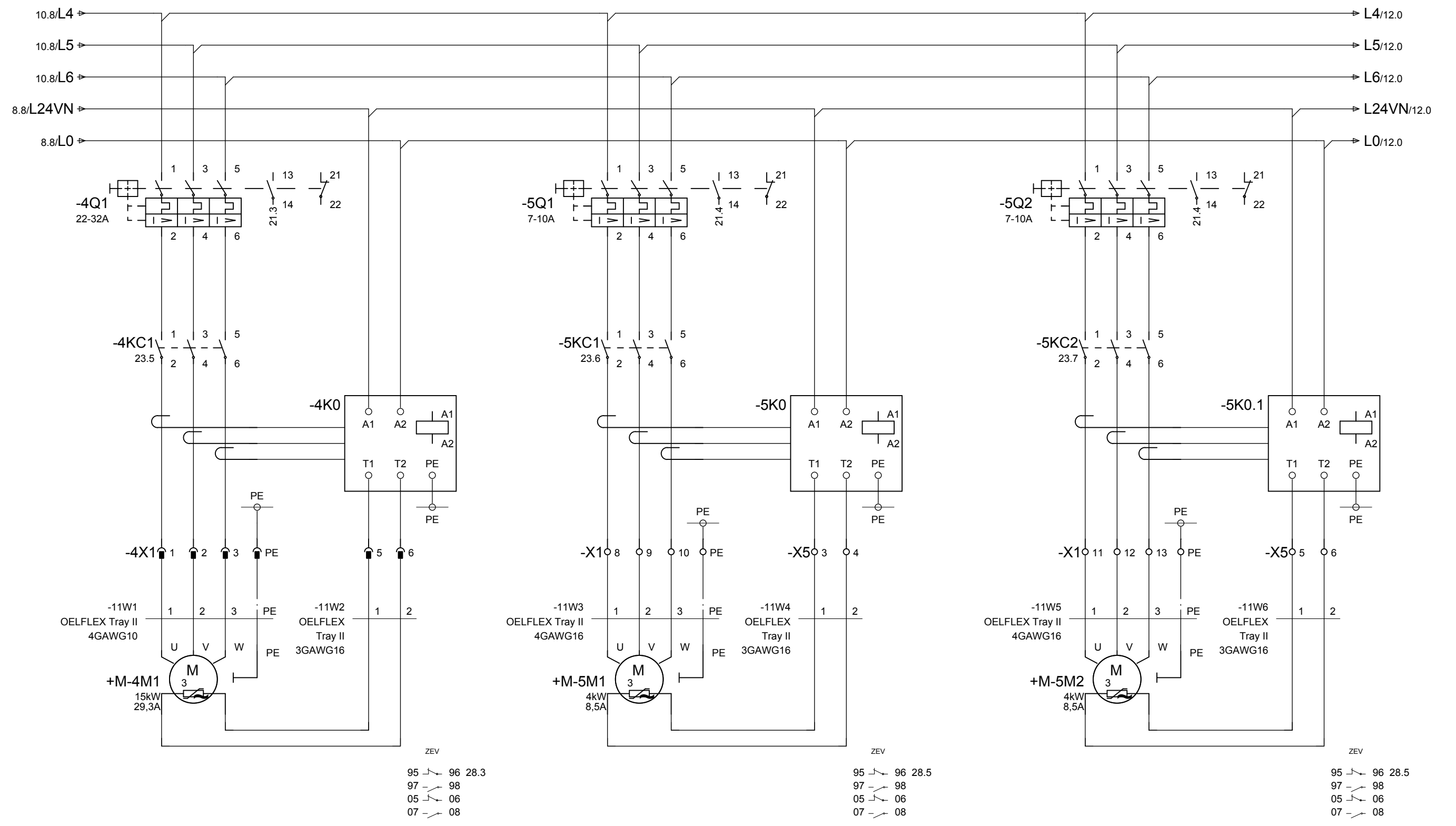

CONVEYOR BELT 4

VIBRATING CHUTE/CRUSHER 5

VIBRATING CHUTE/CRUSHER 5

FOERDERBAND 4

FOERDERRINNE 5

FOERDERRINNE 5

DATE	18.Apr.2012	KLEEMANN GMBH			MOTOREN/ DRIVES	KLEEMANN SERIES	K007	= 100	+
EDITED	JHE	MOBICAT MC 120 Z US				KLEEMANN MATERIAL NO	M20000111_01	CAE-SYSTEM: EPLAN 5.70	PG. 11
CONTR.	D. MALLKOWSKY	ORIGIN	REP.F.	REP.T.				PG. 41	

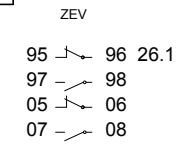
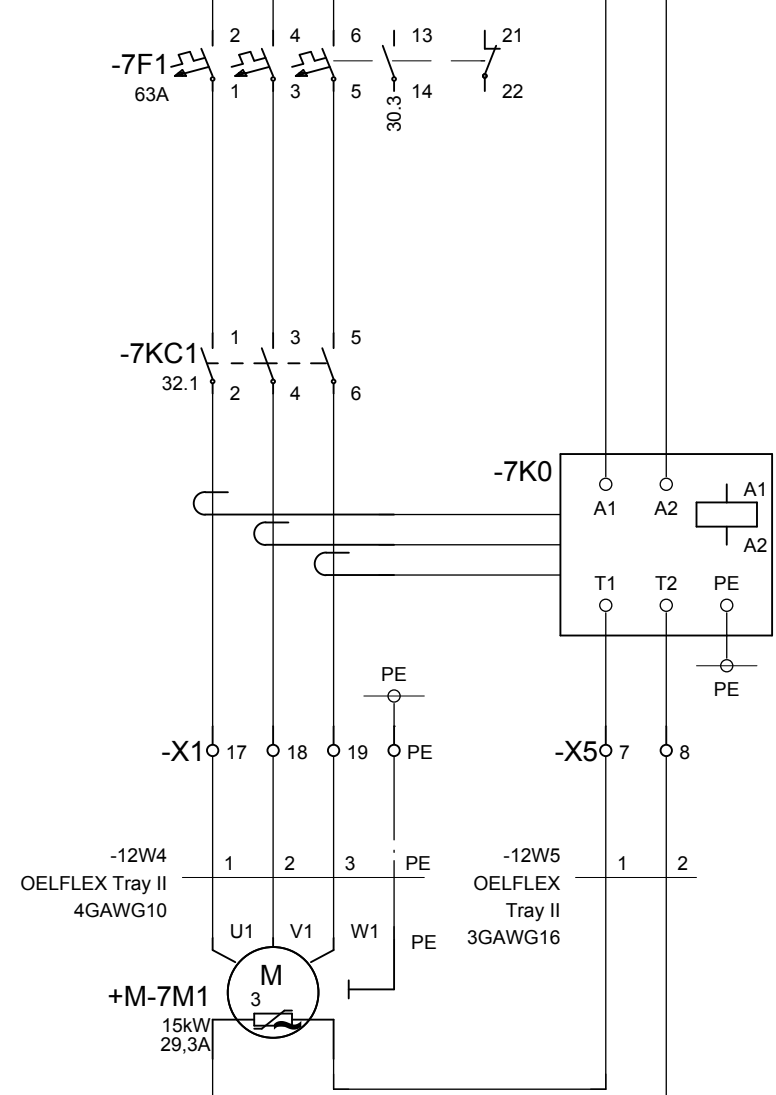
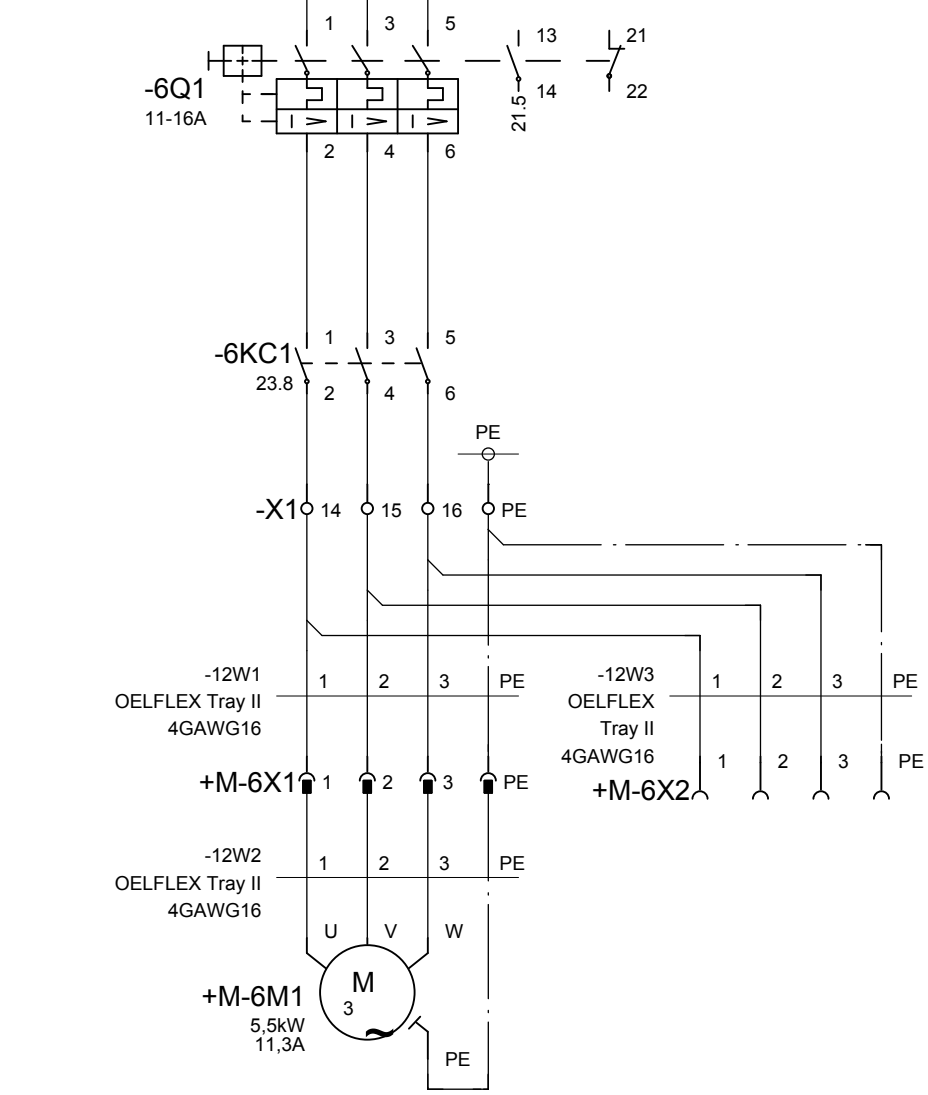
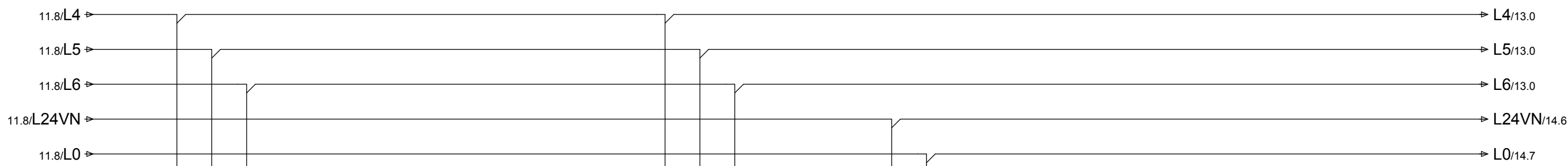

DATE	18.Apr.2012	KLEEMANN GMBH		<b>Kleemann</b>	MOTOREN/ DRIVES	KLEEMANN SERIES	K007	= 100	+
EDITED	JHE	MOBICAT MC 120 Z US				KLEEMANN MATERIAL NO	M20000111_01	CAE-SYSTEM: EPLAN 5.70	PG. 12
CONTR.	D. MALLKOWSKY	ORIGIN	REP.F.	REP.T.			PG. 41		



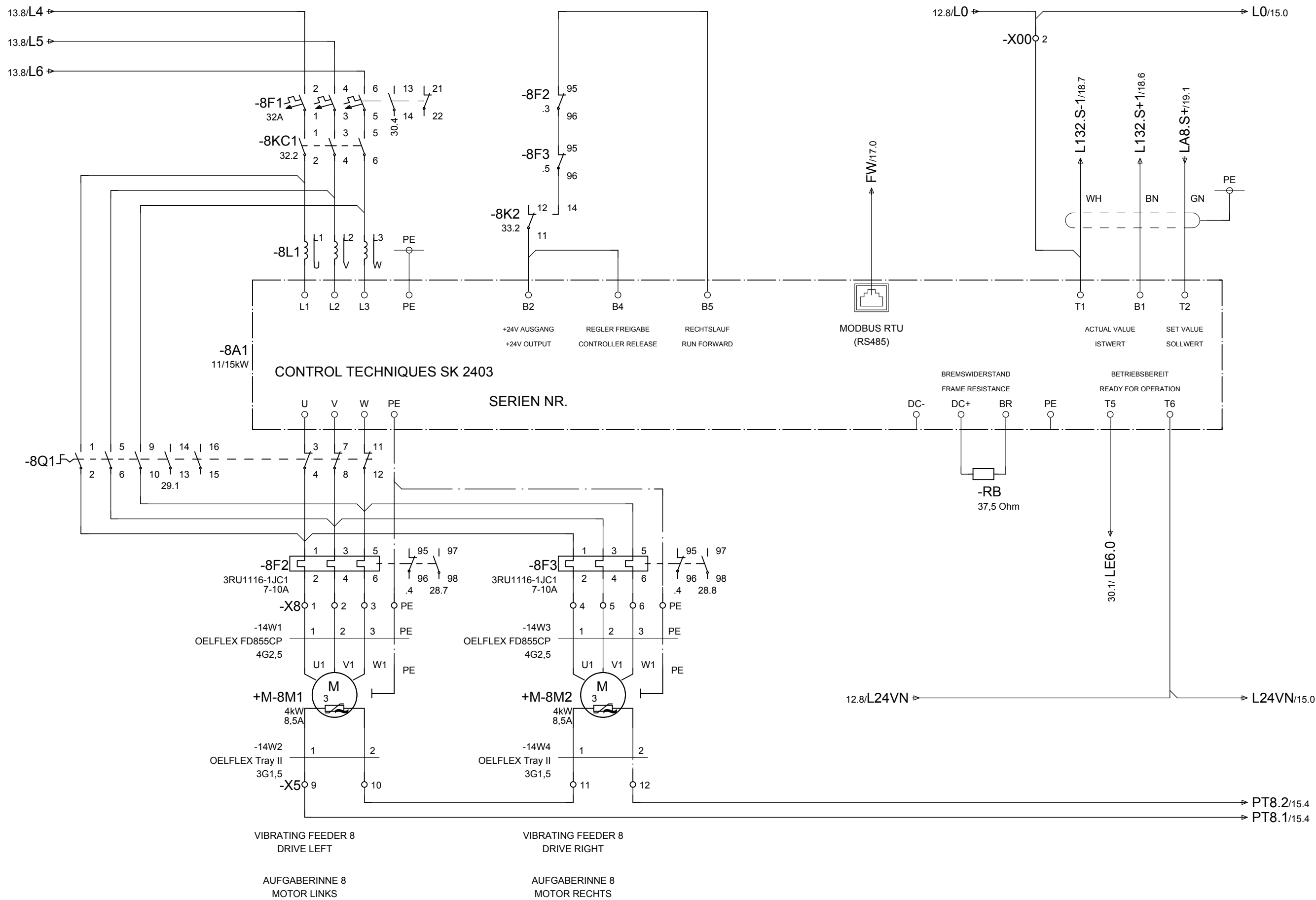

PT8.2/15.4  
PT8.1/15.4

DATE		18.Apr.2012		KLEEMANN GMBH		WIRTGEN GROUP		AUFGABERINNE 8 - POS. 2/ VIBRATING FEEDER 8 - POS. 2		KLEEMANN SERIES		K007		= 100		+	
EDITED		JHE		MOBICAT MC 120 Z US		KLEEMANN				KLEEMANN MATERIAL NO		M20000111_01		CAE-SYSTEM: EPLAN 5.70		PG. 14	
CONTR.		D. MALLKOWSKY		ORIGIN		REP.F.		REP.T.						PG. 41			
MODIFICAT.	DATE	NAME	NORM	DIN	ORIGIN	REP.F.	REP.T.										

14.8/L24VN → L24VN/17.0

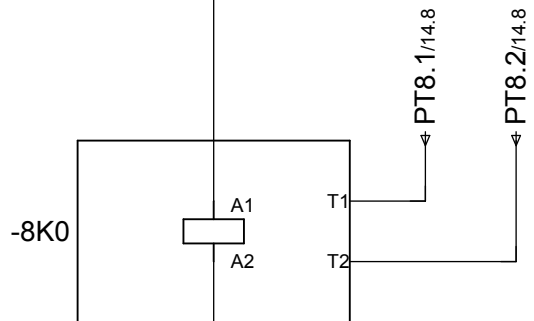

14.8/LO → LO/17.0

SIE 3RN10 10-2CB00  
 95 - 96  
 97 - 98 28.6

TEMPERATURE MONITORING  
 VIBRATING FEEDER 8  
 (8M1/8M2)  
 TEMPERATURUEBERWACHUNG  
 AUFGABERINNE 8  
 (8M1/8M2)

DATE	18.Apr.2012	KLEEMANN GMBH		 	TEMPERATURUEBERWACHUNG/ TEMPERATURE CONTROL	KLEEMANN SERIES	K007	= 100	+
EDITED	JHE	MOBICAT MC 120 Z US				KLEEMANN MATERIAL NO	M20000111_01	CAE-SYSTEM: EPLAN 5.70	PG. 15
CONTR.	D. MALLKOWSKY	ORIGIN	REP.F.	REP.T.			PG. 41		

0

1

2

3

4

5

6

7

8

9

			DATE	18.Apr.2012	KLEEMANN GMBH			 	RESERVE/ SPARE	KLEEMANN SERIES	K007	= 100	+
		EDITED	JHE	MOBICAT MC 120 Z US			KLEEMANN MATERIAL NO			M20000111_01	CAE-SYSTEM: EPLAN 5.70	PG. 16	
MODIFICAT.	DATE	NAME	NORM	DIN	ORIGIN	REP.F.	REP.T.					PG. 41	

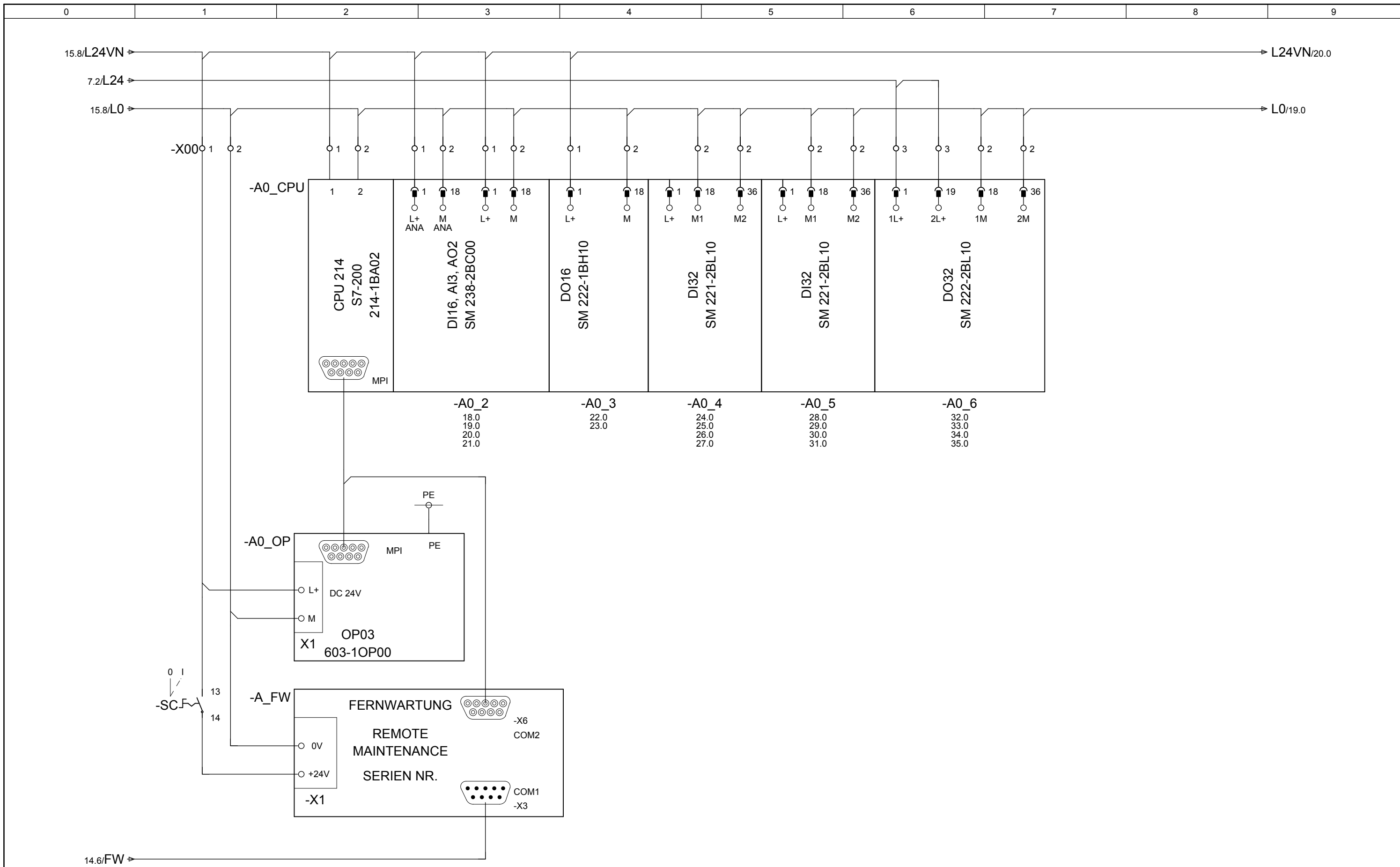

DATE		18.Apr.2012		KLEEMANN GMBH		 	CPU STEUERUNG/ CPU CONTROL SYSTEM		KLEEMANN SERIES		K007		= 100		+	
EDITED		JHE		MOBICAT MC 120 Z US			KLEEMANN MATERIAL NO		M20000111_01		CAE-SYSTEM: EPLAN 5.70		PG.		17	
MODIFICAT.	DATE	NAME	NORM	DIN	ORIGIN	REP.F.	REP.T.					PG.		41		



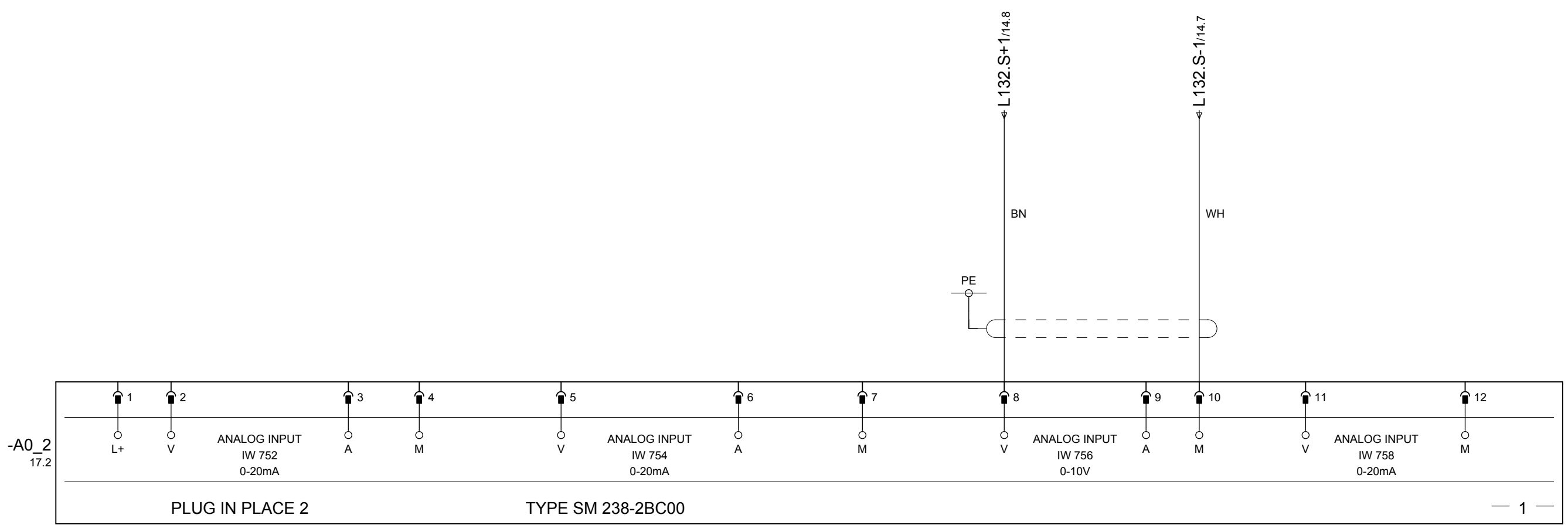

SPARE	SPARE	SPARE	SPARE	ACTUAL VALUE FREQUENCY CONVERTER VIBRATING FEEDER 8	SPARE
RESERVE	RESERVE	RESERVE	RESERVE	ISTWERT FREQUENZUMRICHTER AUFGABERINNE 8	RESERVE

DATE	18.Apr.2012	KLEEMANN GMBH		 	ANALOG EINGAENGE/ ANALOG INPUTS	KLEEMANN SERIES	K007	= 100	+
EDITED	JHE	MOBICAT MC 120 Z US			KLEEMANN MATERIAL NO	M20000111_01	CAE-SYSTEM: EPLAN 5.70	PG. 18	
CONTR.	D. MALLKOWSKY	ORIGIN	REP.F.	REP.T.			PG. 41		

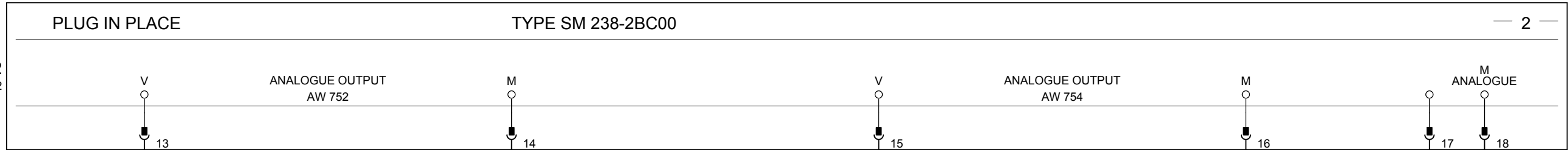

-X00 2

17.8/LO → L0/22.0

SET VALUE  
FREQUENCY CONVERTER  
VIBRATING FEEDER 8  
SOLLWERT  
FREQUENZUMRICHTER  
AUFGABERINNE 8

SPARE  
RESERVE

DATE	18.Apr.2012	KLEEMANN GMBH		 	ANALOGUE AUSGAENGE/ ANALOG OUTPUTS	KLEEMANN SERIES	K007	= 100	+
EDITED	JHE	MOBICAT MC 120 Z US				KLEEMANN MATERIAL NO	M20000111_01	CAE-SYSTEM: EPLAN 5.70	PG. 19
CONTR.	D. MALLKOWSKY	ORIGIN	REP.F.	REP.T.				PG. 41	

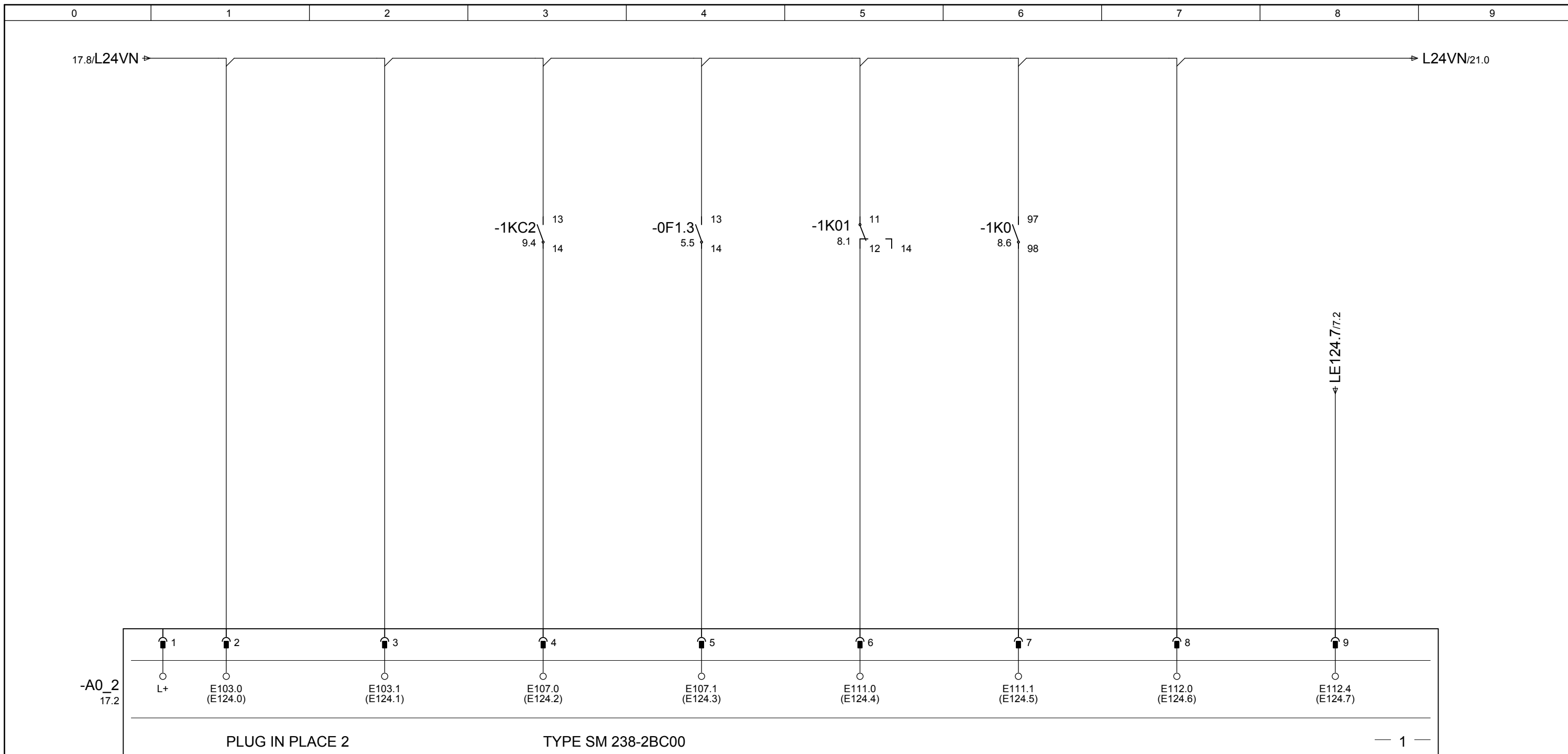

SPARE

SPARE

CRUSHER  
DELTA CONNECTED

MONITORING OF FUSE  
230V

OVERLOAD CRUSHER

MOTOR PROTECTION  
CRUSHER

SPARE

CONTROL VOLTAGE  
EXIST

RESERVE

RESERVE

BRECHER  
IM DREIECK

SICHERUNGS-  
UEBERWACHUNG 230V

BRECHERUEBERLAST

MOTORSCHUTZ  
BRECHER

RESERVE

STEUERSpannung  
VORHANDEN

			DATE	18.Apr.2012	KLEEMANN GMBH			 	DIGITALE EINGAENGE/ DIGITAL INPUTS	KLEEMANN SERIES	K007	= 100	+
			EDITED	JHE	MOBICAT MC 120 Z US					KLEEMANN MATERIAL NO	M20000111_01	CAE-SYSTEM: EPLAN 5.70	PG. 20
MODIFICAT.	DATE	NAME	NORM	DIN	ORIGIN	REP.F.	REP.T.						PG. 41

20.8/L24VN → L24VN/24.0

-2Q1  
10.2

-3Q1  
10.7

-4Q1  
11.2

-5Q1  
11.4

-6Q1  
12.2

-0Q1  
1.2

-GK61  
37.6

-5Q2  
11.7

-0K1  
7.3

-A0\_2  
17.2

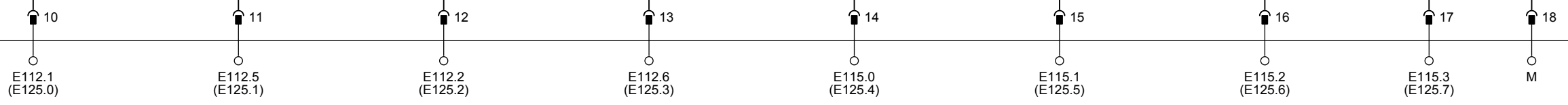

PLUG IN PLACE 2

TYPE SM 238-2BC00

— 2 —

MONITORING MOTOR PROTECTION SWITCH  
UEBERWACHUNG MOTORSCHUTZSCHALTER

MAGNETIC BELT 2	CONVEYOR BELT 3	CONVEYOR BELT 4	VIBRATING CHUTE/ CRUSHER 5	CONVEYOR BELT 6	MAIN SWITCH ON	DIESELMOTOR RUNNING	SPARE
MAGNETBAND 2	FOERDERBAND 3	FOERDERBAND 4	FOERDERRINNE 5	FOERDERBAND 6	HAUPTSCHALTER EIN	DIESELMOTOR LAEUFT	RESERVE

DATE	18.Apr.2012	KLEEMANN GMBH		 	DIGITALE EINGAENGE/ DIGITAL INPUTS	KLEEMANN SERIES	K007	= 100	+
EDITED	JHE	MOBICAT MC 120 Z US			KLEEMANN MATERIAL NO	M20000111_01	CAE-SYSTEM: EPLAN 5.70	PG.	21
CONTR.	D. MALLKOWSKY	ORIGIN	REP.F.	REP.T.				PG.	41

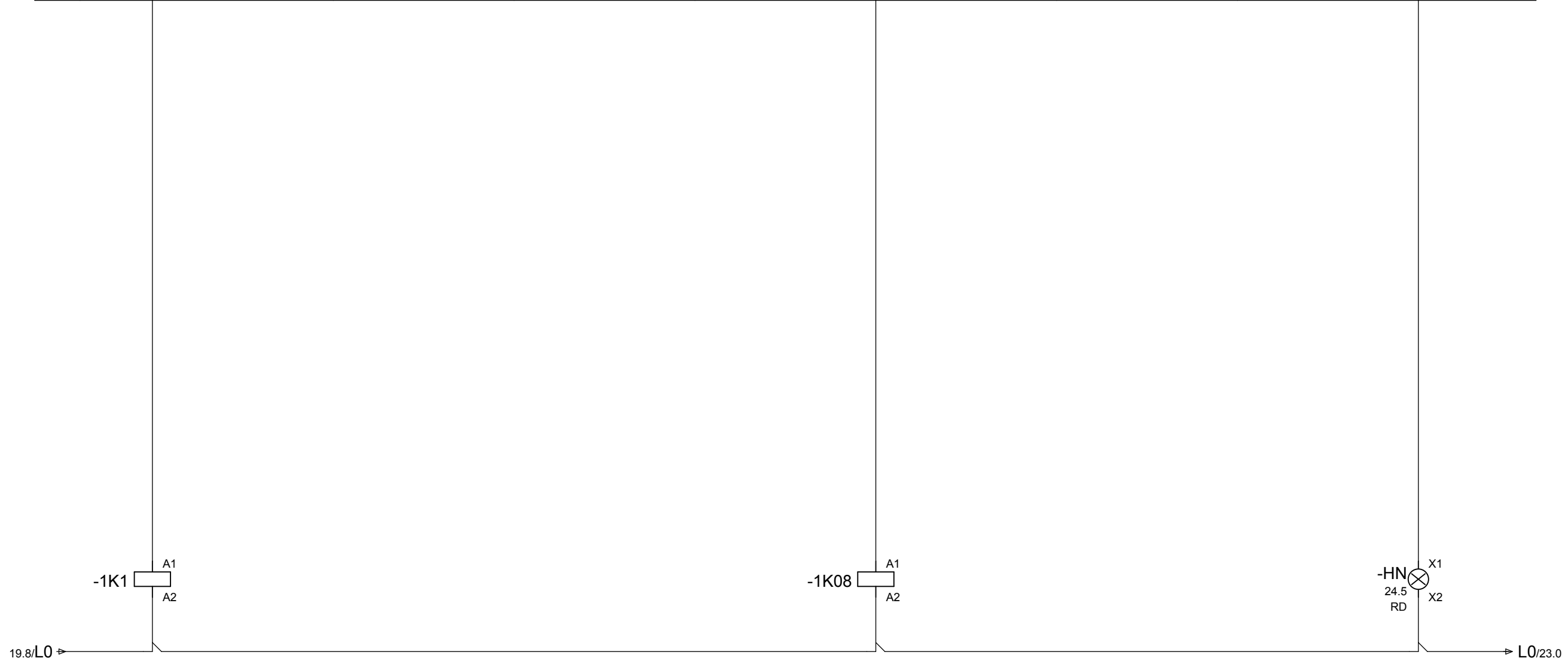
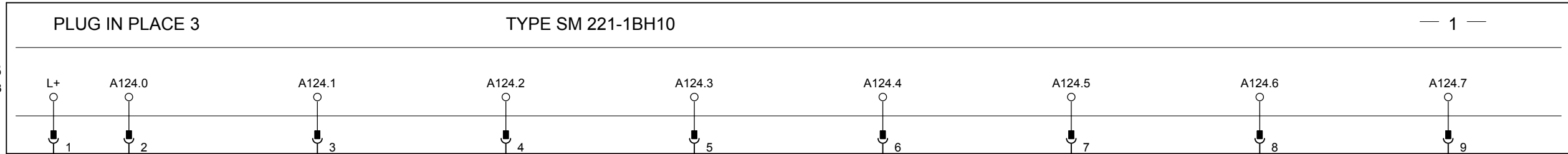

WAGO 788-312  
 14 ↘  
 12 ↘ 11 9.1  
 24 ↘  
 22 ↘ 21

SIE 3RT10 15-2BB41  
 1 ↘ 2 7.5  
 3 ↘ 4  
 5 ↘ 6 41.7  
 13 ↘ 14 7.9

RELEASING CRUSHER	SPARE	SPARE	SPARE	CONTACTOR COUPLING ON	SPARE	SPARE	EMERGENCY STOP
FREIGABE BRECHER	RESERVE	RESERVE	RESERVE	SCHUETZ FAHRKUPPLUNG	RESERVE	RESERVE	NOT-AUS

DATE	18.Apr.2012	KLEEMANN GMBH				DIGITALE AUSGAENGE	KLEEMANN SERIES	K007	= 100	+
EDITED	JHE	MOBICAT MC 120 Z US				DIGITAL OUTPUTS A 124.0 - A 124.7	KLEEMANN MATERIAL NO	M20000111_01	CAE-SYSTEM: EPLAN 5.70	PG. 22
CONTR.	D. MALLKOWSKY	ORIGIN	REP.F.	REP.T.					PG. 41	

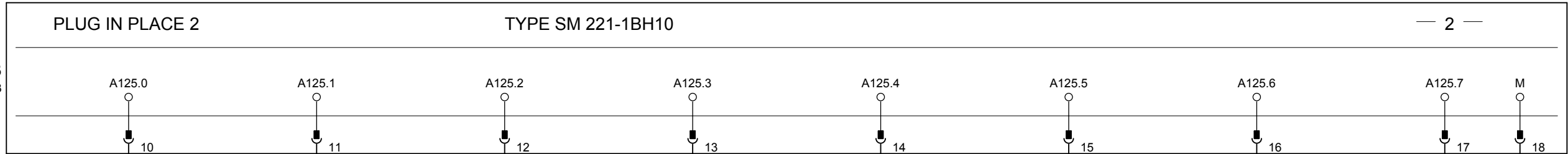

-A0\_3  
17.3

— 2 —

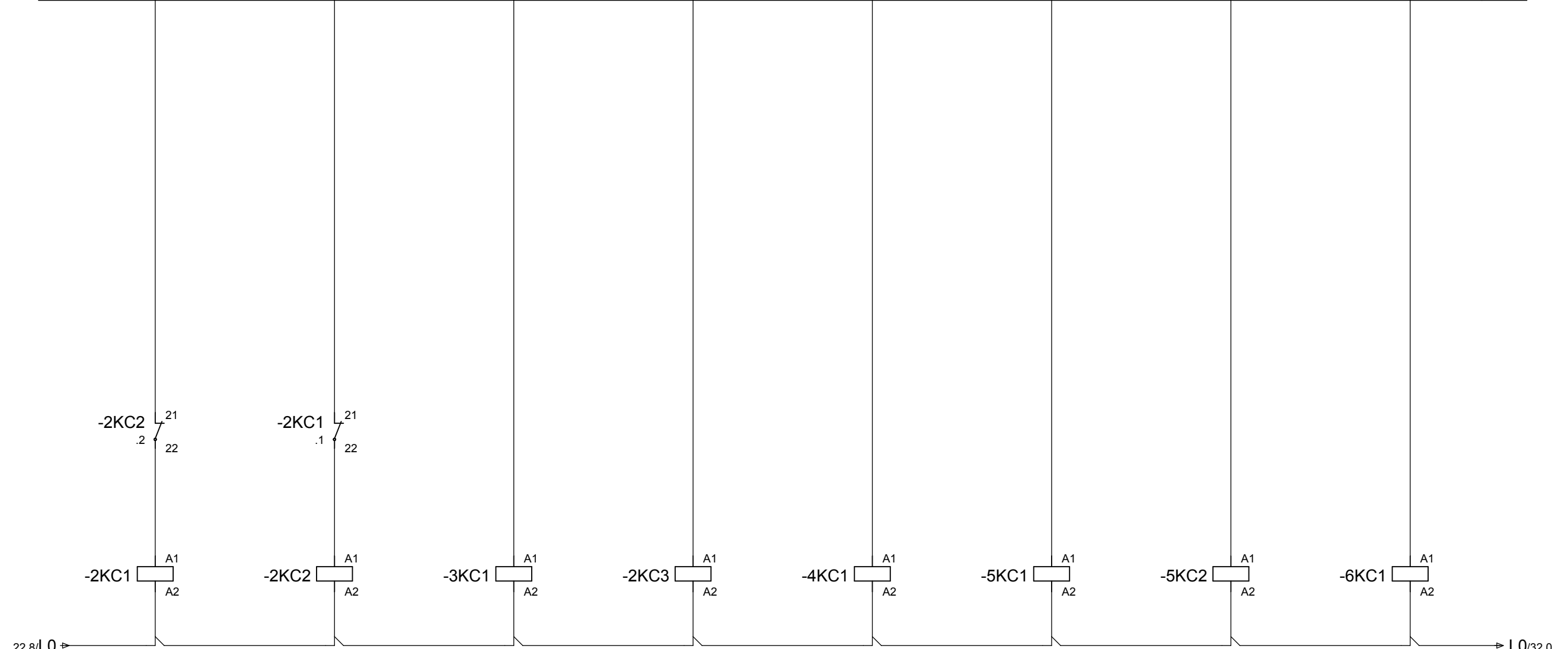

SIE 3RT10 15-2BB42	SIE 3RT10 15-2BB42	SIE 3RT10 17-2BB41	SIE 3RT10 26-3BB40	SIE 3RT10 34-3BB40	SIE 3RT10 16-2BB41	SIE 3RT10 16-2BB41	SIE 3RT10 17-2BB41
1 → 2 10.1 3 → 4 10.1 5 → 6 10.1 21 → 22 .2	1 → 2 10.2 3 → 4 10.2 5 → 6 10.2 21 → 22 .1	1 → 2 10.7 3 → 4 10.7 5 → 6 10.7 13 → 14	1 → 2 10.4 3 → 4 10.4 5 → 6 10.4	1 → 2 11.1 3 → 4 11.1 5 → 6 11.1	1 → 2 11.4 3 → 4 11.4 5 → 6 11.4 13 → 14	1 → 2 11.7 3 → 4 11.7 5 → 6 11.7 13 → 14	1 → 2 12.1 3 → 4 12.1 5 → 6 12.1 13 → 14

MAGNETIC BELT 2 LEFT/RIGHT	MAGNETIC BELT 2 RIGHT	CONVEYOR BELT 3	MAGNET	CONVEYOR BELT 4	VIBRATING CHUTE/ CRUSHER 5 M1	VIBRATING CHUTE/ CRUSHER 5 M2	CONVEYOR BELT 6
MAGNETBAND 2 LINKS	MAGNETBAND 2 RECHTS	FOERDERBAND 3	MAGNET	FOERDERBAND 4	FOERDERRINNE 5 M1	FOERDERRINNE 5 M2	FOERDERBAND 6

DATE	18.Apr.2012	KLEEMANN GMBH			<b>Kleemann</b>	DIGITALE AUSGAENGE	KLEEMANN SERIES	K007	= 100	+
EDITED	JHE	MOBICAT MC 120 Z US				DIGITAL OUTPUTS A 125.0 - A 125.7/	KLEEMANN MATERIAL NO	M20000111_01	CAE-SYSTEM: EPLAN 5.70	PG.
CONTR.	D. MALLKOWSKY	ORIGIN	REP.F.	REP.T.	DIGITAL OUTPUTS A 125.0 - A 125.7				PG.	41

21.8/L24VN → L24VN/25.0

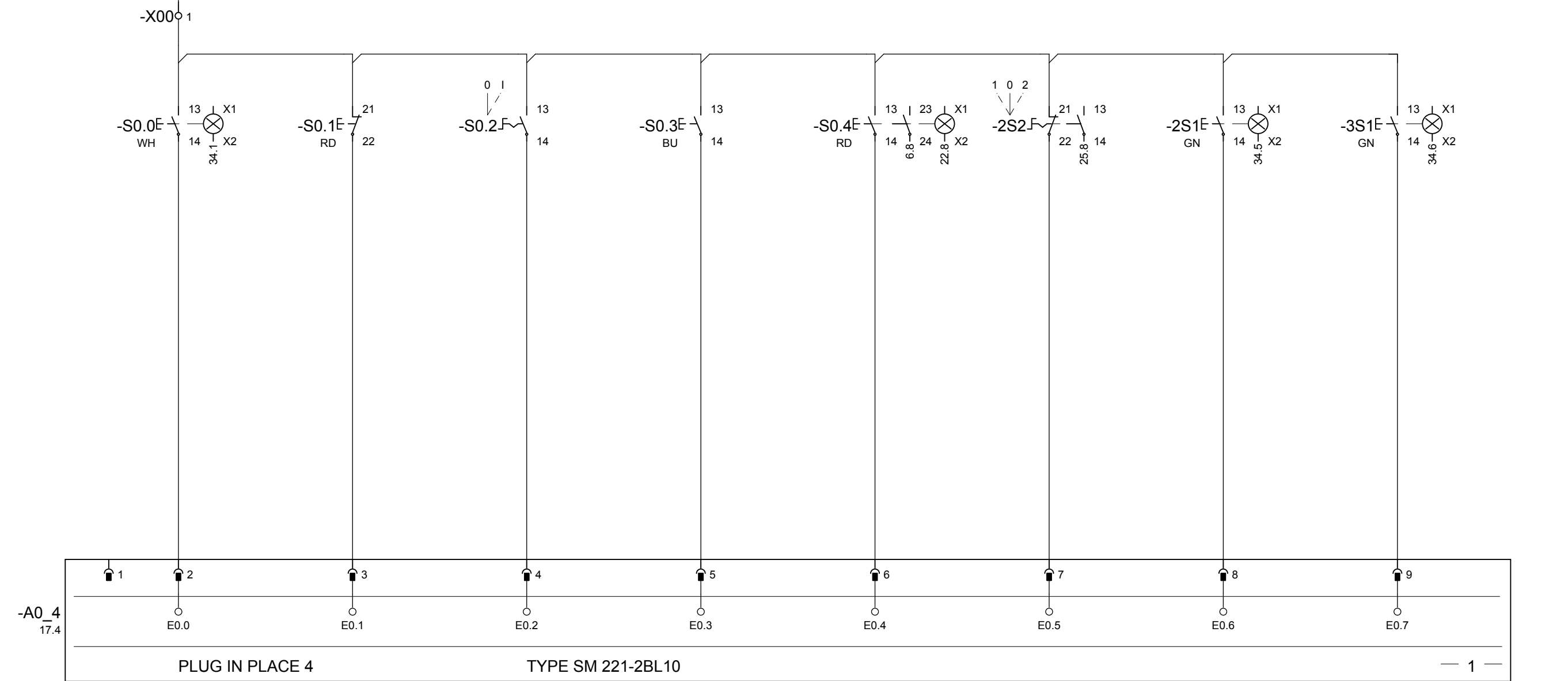

-A0\_4 17.4

1 2 3 4 5 6 7 8 9

E0.0 E0.1 E0.2 E0.3 E0.4 E0.5 E0.6 E0.7

PLUG IN PLACE 4 TYPE SM 221-2BL10 — 1 —

INSTALLATION ON	INSTALLATION OFF	AUTO/REPAIR	LAMP TEST	EMERGENCY STOP RESET	MAGNETIC BELT 2 POSITION 0	MAGNETIC BELT 2 ON/OFF	CONVEYOR BELT 3 ON/OFF
ANLAGE EIN	ANLAGE AUS	AUTO/REPARATUR	LAMPENTEST	NOT-AUS STOERUNG QUITTIEREN	MAGNETBAND 2 POSITION 0	MAGNETBAND 2 EIN/AUS	FOERDERBAND 3 EIN/AUS

DATE	18.Apr.2012	KLEEMANN GMBH				DIGITALE EINGAENGE E 0.0 - E 0.7/ DIGITAL INPUTS E 0.0 - E 0.7	KLEEMANN SERIES	K007	= 100	+
EDITED	JHE	MOBICAT MC 120 Z US				KLEEMANN MATERIAL NO	M20000111_01	CAE-SYSTEM: EPLAN 5.70	PG.	24
CONTR.	D. MALLKOWSKY	ORIGIN	REP.F.	REP.T.					PG.	41

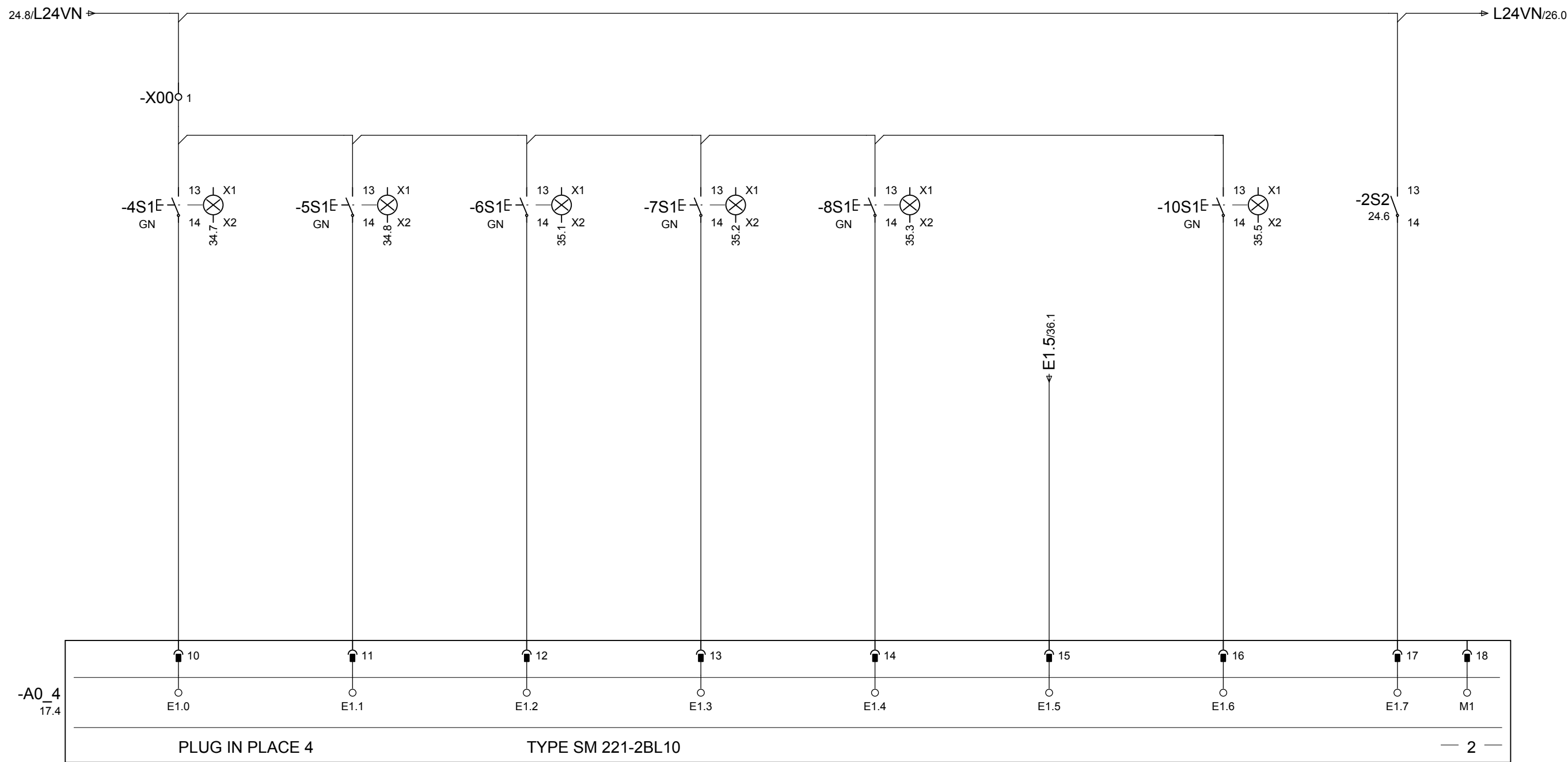

CONVEYOR BELT 4  
ON/OFF  
  
FOERDERBAND 4  
EIN/AUS

VIBRATING CHUTE/  
CRUSHER 5  
ON/OFF  
  
FOERDERRINNE 5  
EIN/AUS

CONVEYOR BELT 6  
ON/OFF  
  
FOERDERBAND 6  
EIN/AUS

VIBRATING SCREEN 7  
ON/OFF  
  
VIBRATIONSSIEB 7  
EIN/AUS

VIBRATING FEEDER 8  
ON/OFF  
  
AUFGABERINNE 8  
EIN/AUS

LIGHT BARRIER  
  
LICHTSCHRANKE

WATERPUMP 10  
ON/OFF  
  
WASSERPUMPE 10  
EIN/AUS

MAGNETIC BELT 2  
RIGHT  
  
MAGNETBAND 2  
RECHTS

DATE	18.Apr.2012	KLEEMANN GMBH		 	DIGITALE EINGAENGE E 1.0 - E 1.7/ DIGITAL INPUTS E 1.0 - E 1.7	KLEEMANN SERIES	K007	= 100	+
EDITED	JHE	MOBICAT MC 120 Z US					KLEEMANN MATERIAL NO	M20000111_01	CAE-SYSTEM: EPLAN 5.70
CONTR.	D. MALLKOWSKY	ORIGIN	REP.F.	REP.T.					PG. 41



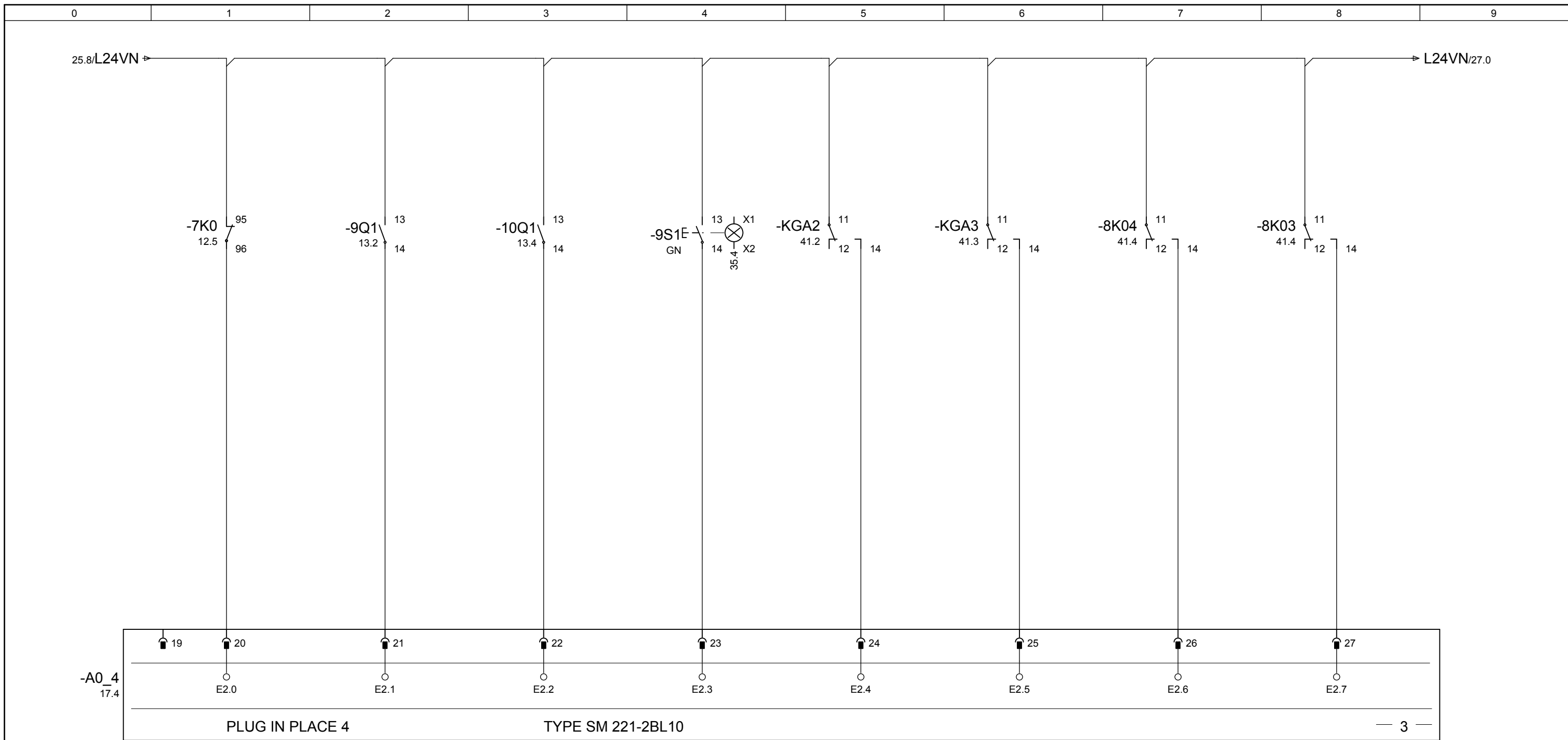

TEMPERATURE  
VIBRATING SCREEN 7

TEMPERATUR  
VIBRATIONSSIEB 7

MOTOR PROTECTION  
HYDRAULIC

MOTORSCHUTZ  
HYDRAULIK

MOTOR PROTECTION  
WATERPUMP

MOTORSCHUTZ  
WASSERPUMPE

HYDRAULIC

HYDRAULIK

VIBRATING CHUTE  
+SCREEN ON  
(REMOTE)

RINNE+SIEB  
EIN  
(FUNK)

VIBRATING CHUTE  
+SCREEN OFF  
(REMOTE)

RINNE+SIEB  
AUS  
(FUNK)

VIBRATING CHUTE  
SLOWER  
(RADIO)

RINNE  
LANGSAMER  
(FUNK)

VIBRATING CHUTE  
FASTER  
(RADIO)

RINNE  
SCHNELLER  
(FUNK)

DATE	18.Apr.2012	KLEEMANN GMBH		 	DIGITAL EINGAENGE E 2.0 - E 2.7/ DIGITAL INPUTS E 2.0 - E 2.7	KLEEMANN SERIES	K007	= 100	+
EDITED	JHE	MOBICAT MC 120 Z US			KLEEMANN MATERIAL NO	M20000111_01	CAE-SYSTEM: EPLAN 5.70	PG.	26
CONTR.	D. MALLKOWSKY	ORIGIN	REP.F.	REP.T.				PG.	41

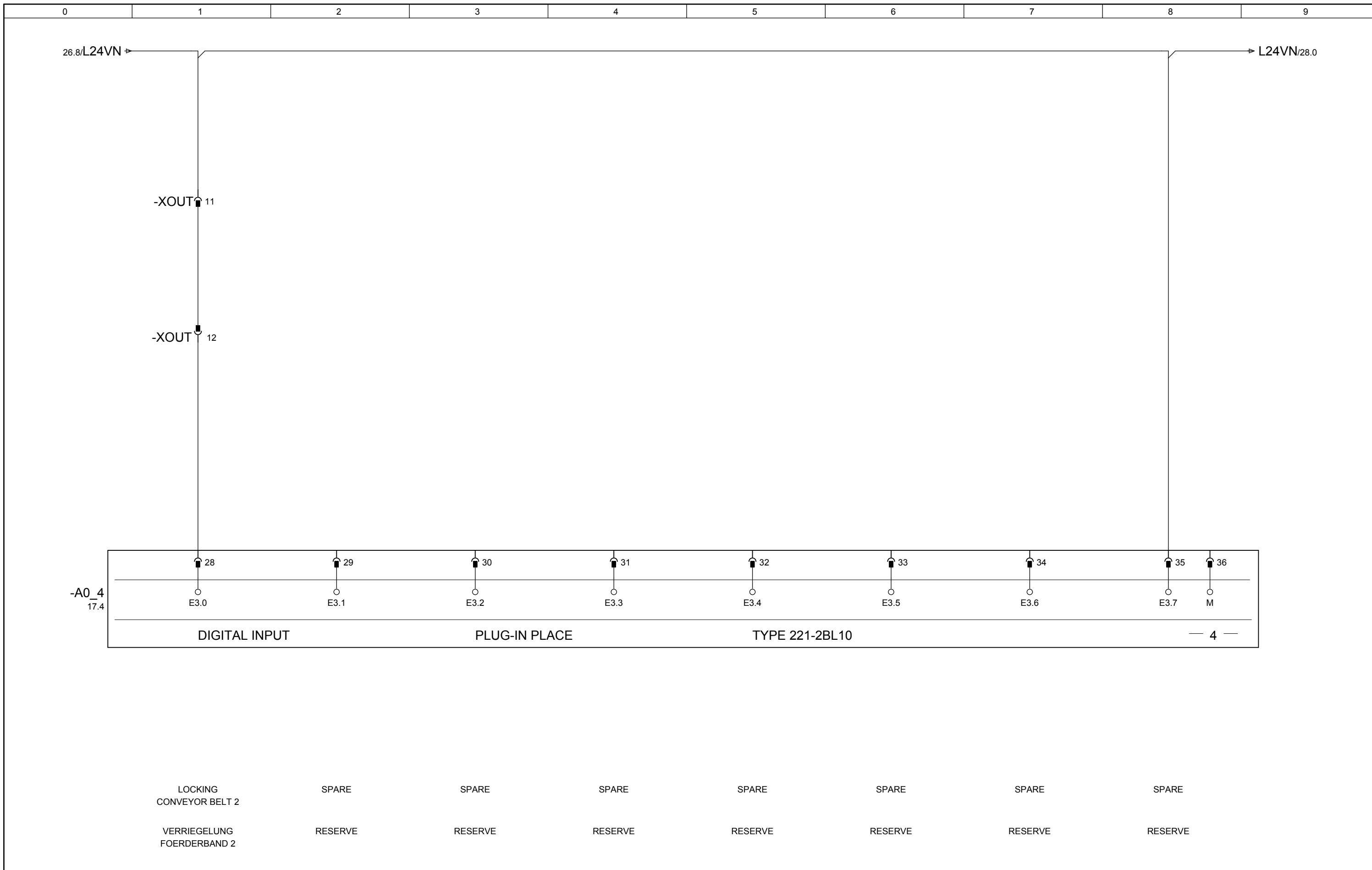

DATE		18.Apr.2012		KLEEMANN GMBH			 	DIGITAL EINGAENGE E 3.0 - E 3.7/ DIGITAL INPUTS E 3.0 - E 3.7		KLEEMANN SERIES K007		= 100		+	
EDITED		JHE		MOBICAT MC 120 Z US						KLEEMANN MATERIAL NO M20000111_01		CAE-SYSTEM: EPLAN 5.70		PG. 27	
CONTR.		D. MALLKOWSKY												PG. 41	
MODIFICAT.	DATE	NAME	NORM	DIN	ORIGIN	REP.F.	REP.T.								

27.9/L24VN → L24VN/29.0

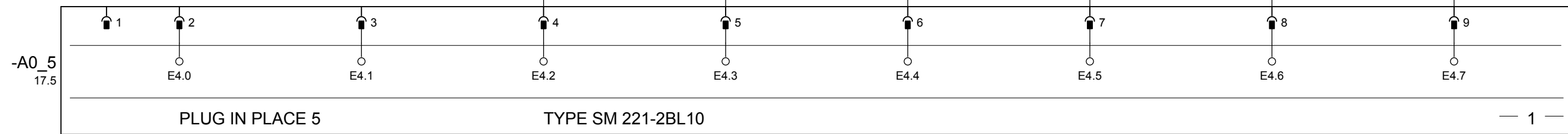
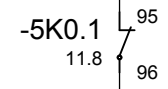

SPARE	SPARE	TEMPERATURE MONITORING CONVEYOR BELT 4	MOTOR PROTECTION PRESSURE BURDEN	TEMP. MONITORING VIBRATING CHUTE/ CRUSHER 5	TEMP. MONITORING VIBRATING FEEDER 8	MOTOR PROTECTION VIBRATING FEEDER 8	MOTOR PROTECTION VIBRATING FEEDER 8
RESERVE	RESERVE	TEMP.-UEBERWACHUNG FOERDERBAND 4	MOTORSCHUTZ UEBERDRUCK	TEMP.-UEBERWACHUNG FOERDERRINNE 5	TEMP.-UEBERWACHUNG AUFGABERINNE 8	MOTORSCHUTZ AUFGABERINNE 8	MOTORSCHUTZ AUFGABERINNE 8

DATE	18.Apr.2012	KLEEMANN GMBH			DIGITAL EINGAENGE E 4.0 - E 4.7/ DIGITAL INPUTS E 4.0 - E 4.7	KLEEMANN SERIES	K007	= 100	+
EDITED	JHE	MOBICAT MC 120 Z US				KLEEMANN MATERIAL NO	M20000111_01	CAE-SYSTEM: EPLAN 5.70	PG. 28
CONTR.	D. MALLKOWSKY	ORIGIN	REP.F.	REP.T.				PG. 41	

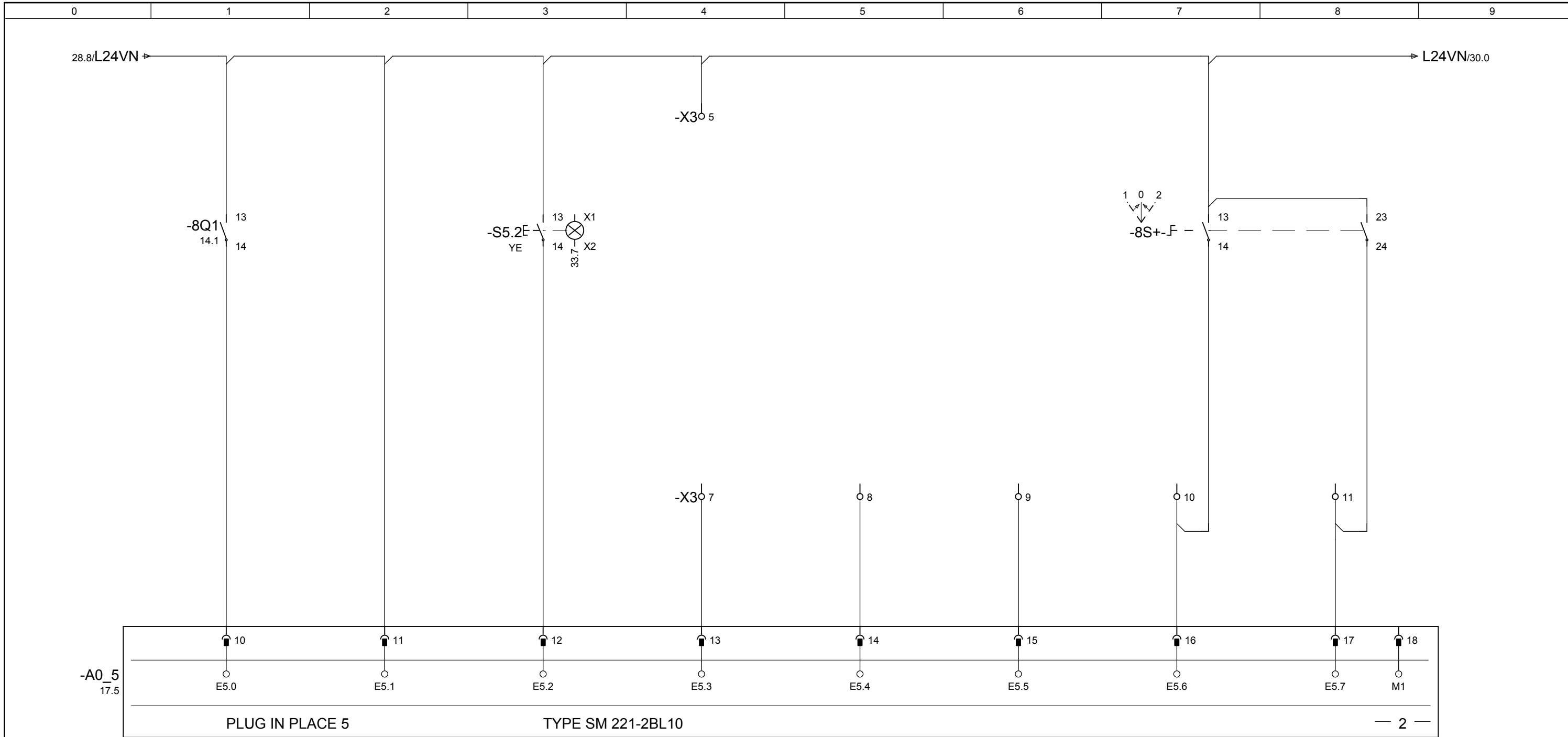

	VIBRATING FEEDER FREQUENCY CONVERTER/ MAIN	SPARE	COUPLING ON/OFF	SPARE	SPARE	SPARE	VIBRATING FEEDER 8 +	VIBRATING FEEDER 8 -
	AUFGABERINNE FU/NETZ	RESERVE	KUPPLUNG EIN/AUS	RESERVE	RESERVE	RESERVE	AUFGABERINNE 8 +	AUFGABERINNE 8 -

DATE	18.Apr.2012	KLEEMANN GMBH				DIGITALE EINGAENGE E 5.0 - E 5.7/ DIGITAL INPUTS E 5.0 - E 5.7	KLEEMANN SERIES	K007	= 100	+
EDITED	JHE	MOBICAT MC 120 Z US				KLEEMANN MATERIAL NO	M20000111_01	CAE-SYSTEM: EPLAN 5.70	PG.	29
CONTR.	D. MALLKOWSKY	ORIGIN	REP.F.	REP.T.					PG.	41

29.8/L24VN → → L24VN/31.0

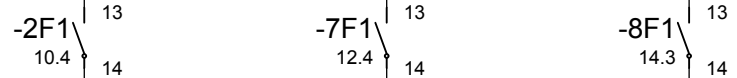

LE6.0/14.8

-A0\_5  
17.5

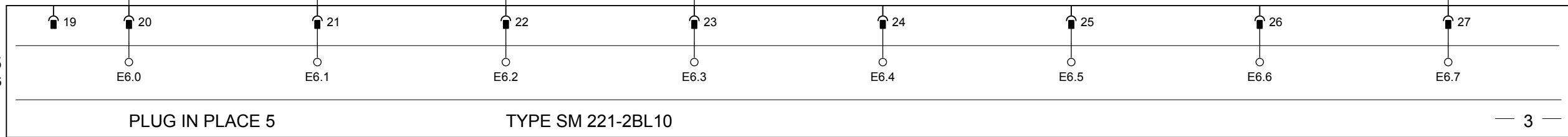

MALFUNCTION  
FREQUENCY CONVERTER  
VIBRATING FEEDER 8  
  
STOERUNG FU  
AUFGABERINNE 8

SUPERVISION OF FUSE  
MAGNET 2  
  
SICHERUNGS-  
UEBERWACHUNG  
MAGNET 2

SUPERVISION OF FUSE  
SCREEN 7  
  
SICHERUNGS-  
UEBERWACHUNG  
SIEB 7

SUPERVISION OF FUSE  
VIBRATING FEEDER 8  
  
SICHERUNGS-  
UEBERWACHUNG  
AUFGABERINNE 8

SPARE  
  
RESERVE

SPARE  
  
RESERVE

SPARE  
  
RESERVE

SPARE  
(FLOW GUARD)  
  
RESERVE  
(STROEMUNGSWAECHTER)

			DATE	18.Apr.2012	KLEEMANN GMBH		DIGITALE AUSGAENGE A 6.0 - A 6.7/ DIGITAL OUTPUTS A 6.0 - A 6.7	KLEEMANN SERIES	K007	= 100	+	
			EDITED	JHE	MOBICAT MC 120 Z US			KLEEMANN MATERIAL NO	M20000111_01	CAE-SYSTEM: EPLAN 5.70	PG.	30
MODIFICAT.	DATE	NAME	NORM	DIN			ORIGIN	REP.F.	REP.T.			PG.

30.8/L24VN → L24VN/36.0

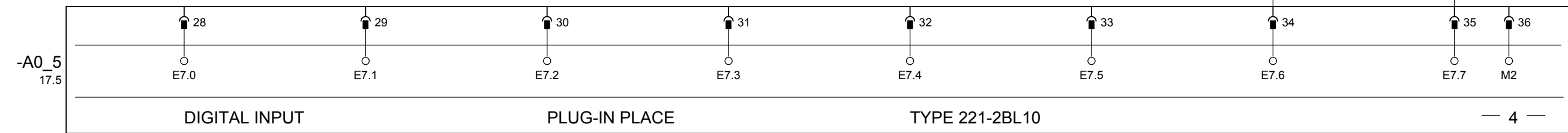
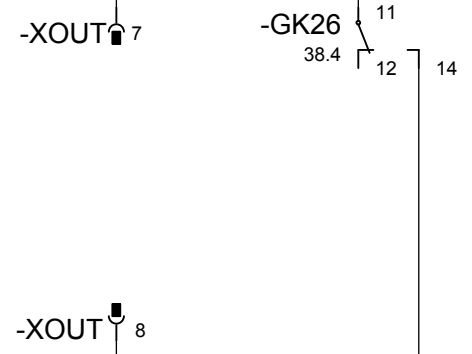

SPARE	SPARE	SPARE	SPARE	SPARE	SPARE	SPARE	OVERLOAD REMOVAL	PREWARNING OIL TEMPERATUR
RESERVE	RESERVE	RESERVE	RESERVE	RESERVE	RESERVE	RESERVE	UEBERLAST ABFOERDERUNG	VORWARNUNG OELTEMPERATUR

DATE	18.Apr.2012	KLEEMANN GMBH			 	DIGITALE AUSGAENGE A 7.0 - A 7.7/ DIGITAL OUTPUTS A 7.0 - A 7.7	KLEEMANN SERIES	K007	= 100	+	
EDITED	JHE	MOBICAT MC 120 Z US					KLEEMANN MATERIAL NO	M20000111_01	CAE-SYSTEM: EPLAN 5.70	PG.	31
CONTR.	D. MALLKOWSKY	ORIGIN	REP.F.	REP.T.						PG.	41
MODIFICAT.	DATE	NAME	NORM	DIN							

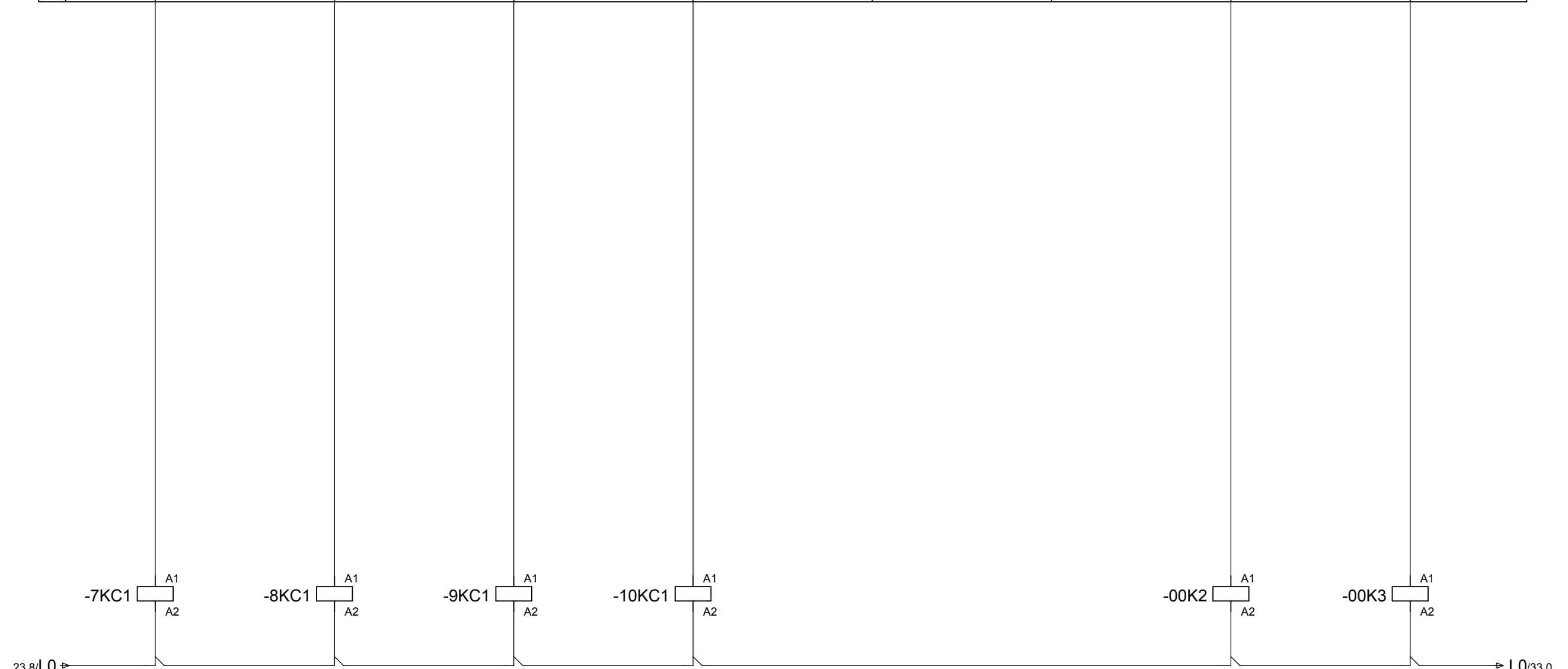
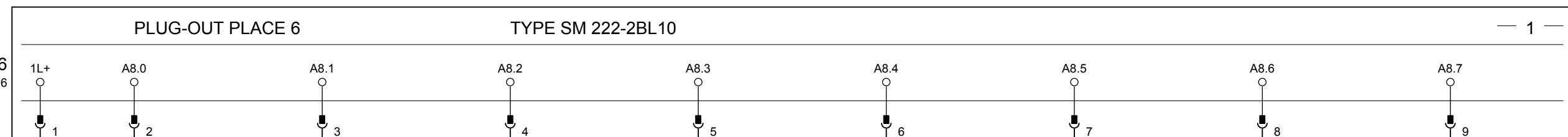

SIE 3RT10 34-3BB40	SIE 3RT10 34-3BB40	SIE 3RT10 16-2BB41	SIE 3RT10 15-2BB41	WAGO 788-312	WAGO 788-312
1 → 2 12.4 3 → 4 12.4 5 → 6 12.4	1 → 2 14.2 3 → 4 14.2 5 → 6 14.3	1 → 2 13.1 3 → 4 13.1 5 → 6 13.1 13 → 14	1 → 2 13.3 3 → 4 13.4 5 → 6 13.4 13 → 14	14 → 11 7.7 24 → 21	14 → 11 7.8 24 → 21

VIBRATING SCREEN 7	VIBRATING FEEDER 8	HYDRAULIC 9	WATERPUMP 10	SPARE	SPARE	HOOTER	FLASHING LIGHT
VIBRATIONSSIEB 7	AUFGABERINNE 8	HYDRAULIK 9	WASSERPUMPE 10	RESERVE	RESERVE	HUPE	BLINKLICHT

DATE	18.Apr.2012	KLEEMANN GMBH			DIGITALE EINGAENGE E 8.0 - E 8.7/ DIGITAL INPUTS E 8.0 - E 8.7	KLEEMANN SERIES	K007	= 100	+
EDITED	JHE	MOBICAT MC 120 Z US			KLEEMANN MATERIAL NO	M20000111_01	CAE-SYSTEM: EPLAN 5.70	PG. 32	
CONTR.	D. MALLKOWSKY	ORIGIN	REP.F.	REP.T.			PG. 41		

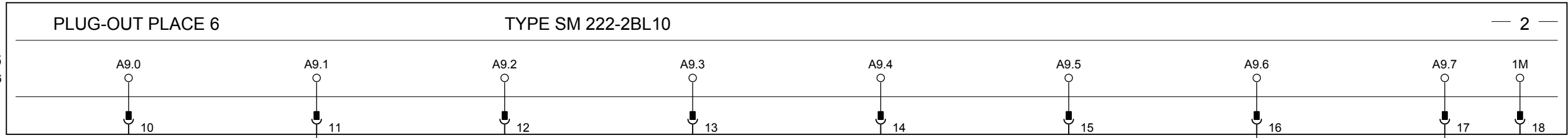

-A0\_6  
17.6

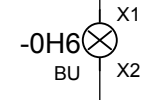
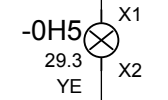
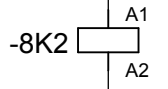

32.8/LO → WAGO 788-312 → LO/34.0

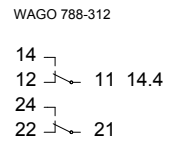

SPARE	START (RELEASING) FREQU. CONV. VIBRATING FEEDER 8	SPARE	SPARE	SPARE	SPARE	COUPLING ENGAGED	START-UP RELEASE
RESERVE	START (FREIGABE) FU AUFGABERINNE 8	RESERVE	RESERVE	RESERVE	RESERVE	KUPPLUNG EINGERUECKT	ANLAUFFREIGABE

DATE	18.Apr.2012	KLEEMANN GMBH				DIGITALE EINGAENGE E 9.0 - E 9.7/ DIGITAL INPUTS E 9.0 - E 9.7	KLEEMANN SERIES	K007	= 100	+
EDITED	JHE	MOBICAT MC 120 Z US				KLEEMANN MATERIAL NO	M20000111_01	CAE-SYSTEM: EPLAN 5.70	PG.	33
CONTR.	D. MALLKOWSKY	ORIGIN	REP.F.	REP.T.					PG.	41



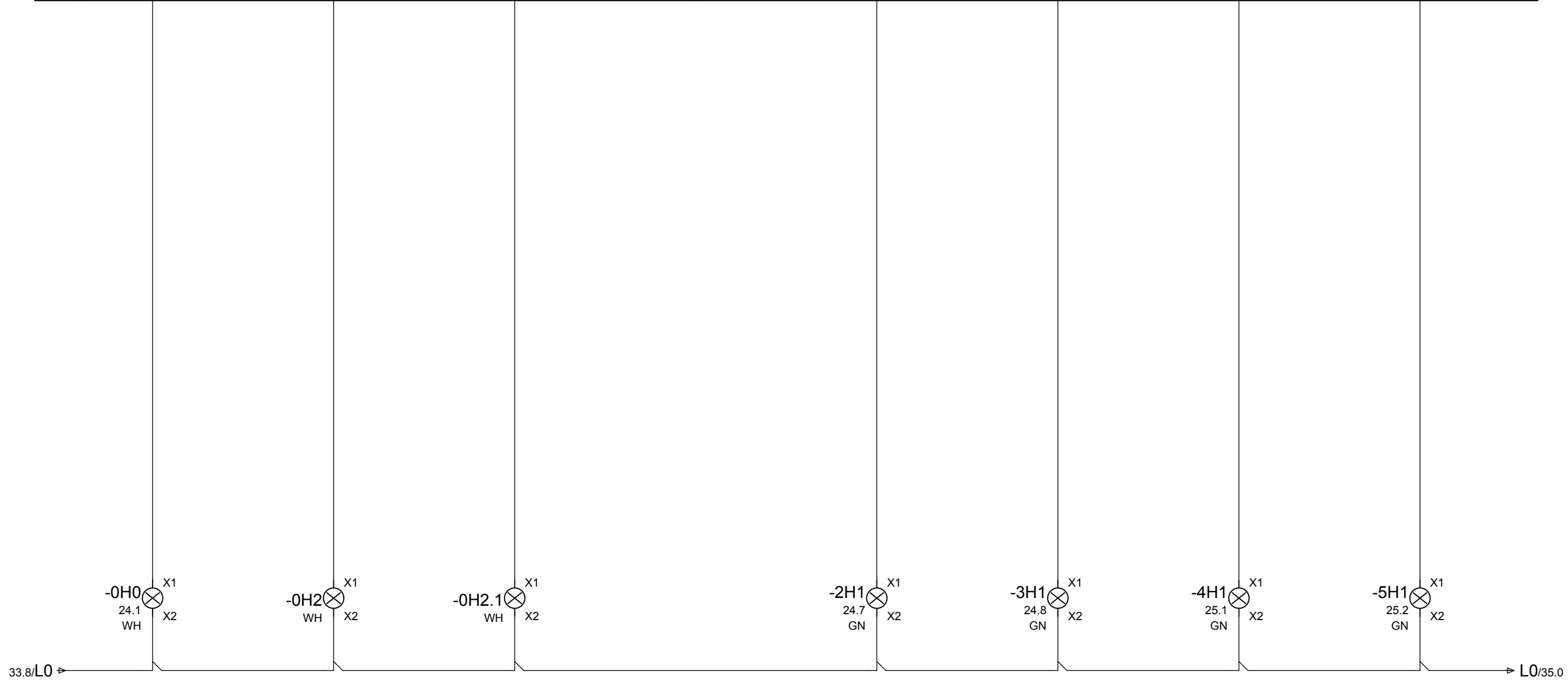
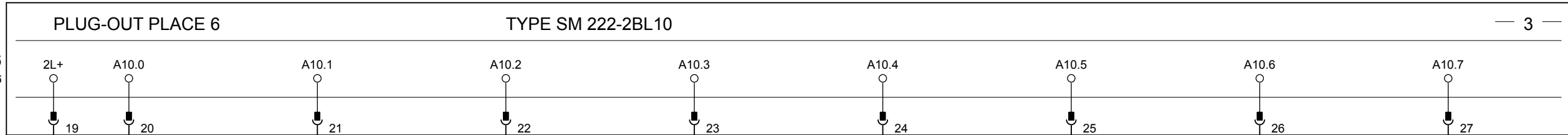

INSTALLATION ON

OPERATION

REPAIR

SPARE

CONVEYOR BELT 2  
ON/OFF

MAGNETIC BELT 3  
ON/OFF

CONVEYOR BELT 4  
ON/OFF

VIBRATING CHUTE/  
CRUSHER 5  
ON/OFF

ANLAGE EIN

BETRIEB

REPARATUR

RESERVE

FOERDERBAND 2  
EIN/AUS

MAGNETBAND 3  
EIN/AUS

FOERDERBAND 4  
EIN/AUS

FOERDERRINNE 5  
EIN/AUS

DATE	18.Apr.2012	KLEEMANN GMBH		 	DIGITALE AUSGAENGE A 10.0 - A 10.7/ DIGITAL OUTPUTS A 10.0 - A 10.7	KLEEMANN SERIES	K007	= 100	+	
EDITED	JHE	MOBICAT MC 120 Z US				KLEEMANN MATERIAL NO	M20000111_01	CAE-SYSTEM: EPLAN 5.70	PG.	34
CONTR.	D. MALLKOWSKY	ORIGIN	REP.F.	REP.T.					PG.	41

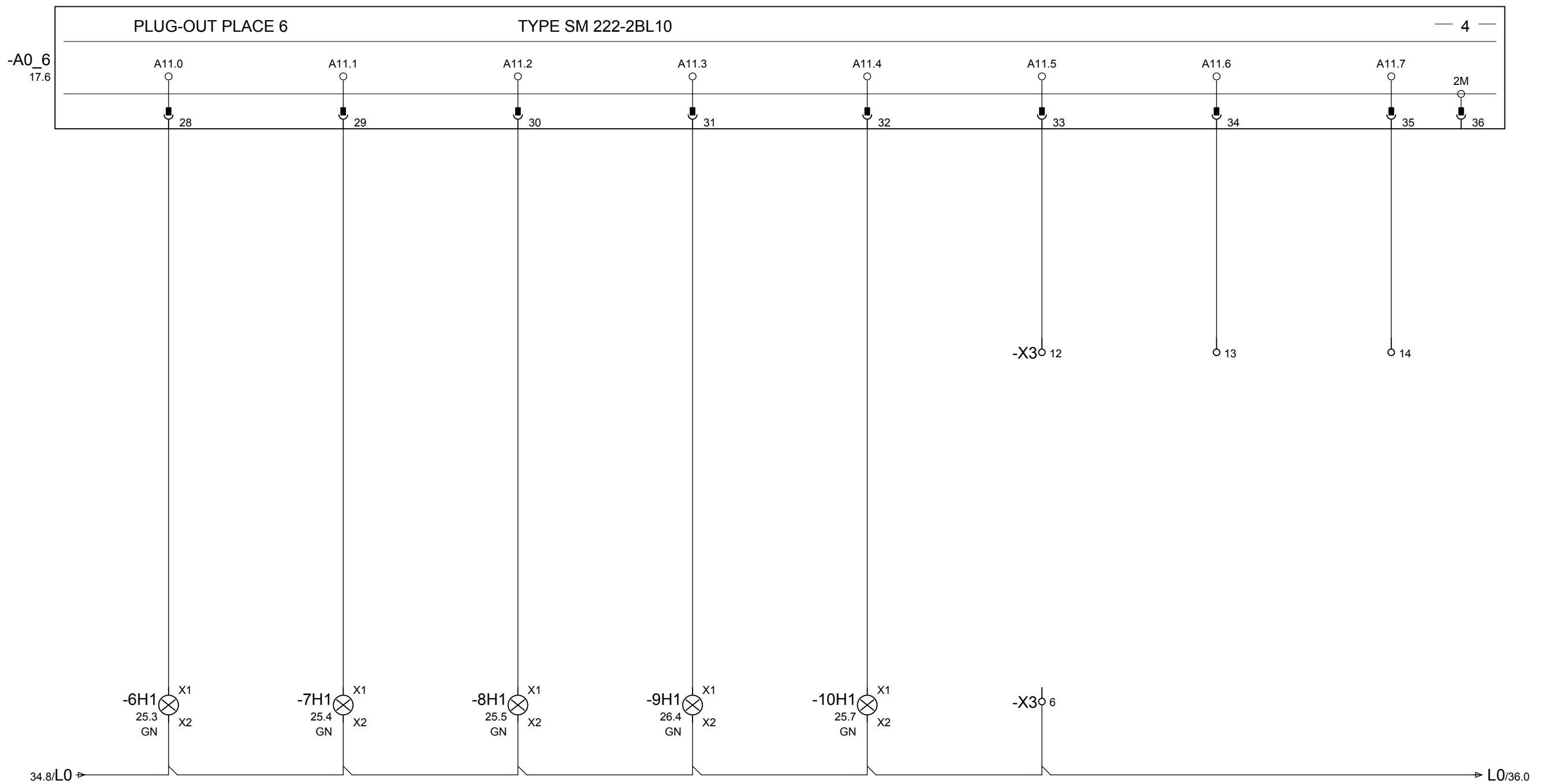

MAGNETIC BELT 6 ON/OFF	CONVEYOR BELT 7 ON/OFF	VIBRATING FEEDER 8 ON/OFF	CONVEYOR BELT 9 ON/OFF	VIBRATING FEEDER 10 ON/OFF	SPARE	SPARE	SPARE
MAGNETBAND 6 EIN/AUS	FOERDERBAND 7 EIN/AUS	AUFGABERINNE 8 EIN/AUS	FOERDERBAND 9 EIN/AUS	AUFGABERINNE 10 EIN/AUS	RESERVE	RESERVE	RESERVE

DATE	18.Apr.2012	KLEEMANN GMBH				DIGITALE AUSGAENGE	KLEEMANN SERIES	K007	= 100	+
EDITED	JHE	MOBICAT MC 120 Z US				DIGITAL OUTPUTS A 11.0 - A 11.7/	KLEEMANN MATERIAL NO	M20000111_01	CAE-SYSTEM: EPLAN 5.70	PG. 35
CONTR.	D. MALLKOWSKY	ORIGIN	REP.F.	REP.T.	DIGITAL OUTPUTS A 11.0 - A 11.7				PG. 41	

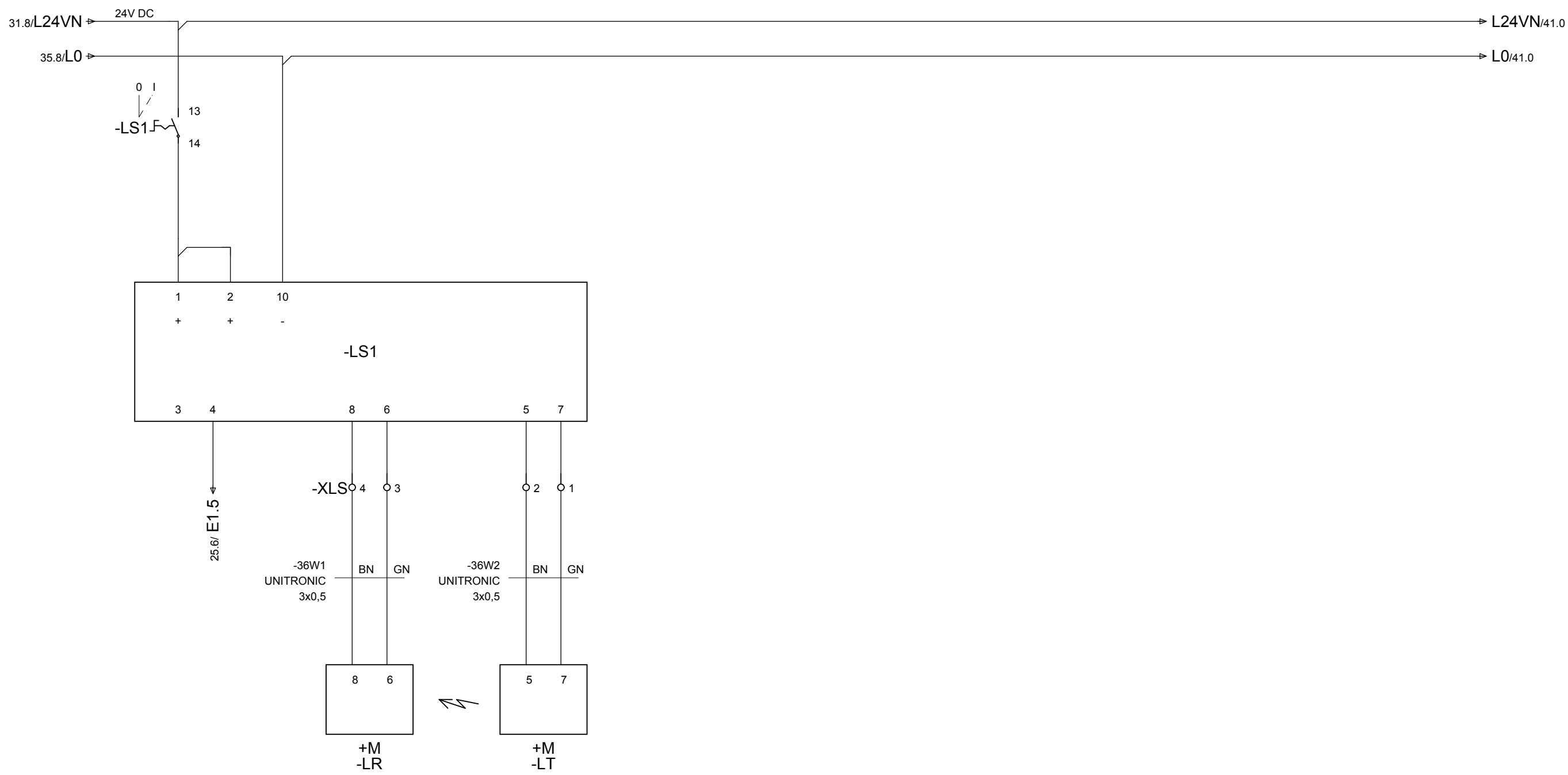

LIGHT BARRIER CRUSHER

LICHTSCHRANKE BRECHER

DATE	18.Apr.2012	KLEEMANN GMBH		 	LICHTSCHRANKE BRECHER/ LIGHT BARRIER CRUSHER	KLEEMANN SERIES	K007	= 100	+
EDITED	JHE	MOBICAT MC 120 Z US				KLEEMANN MATERIAL NO	M20000111_01	CAE-SYSTEM: EPLAN 5.70	PG. 36
CONTR.	D. MALLKOWSKY	ORIGIN	REP.F.	REP.T.				PG. 41	



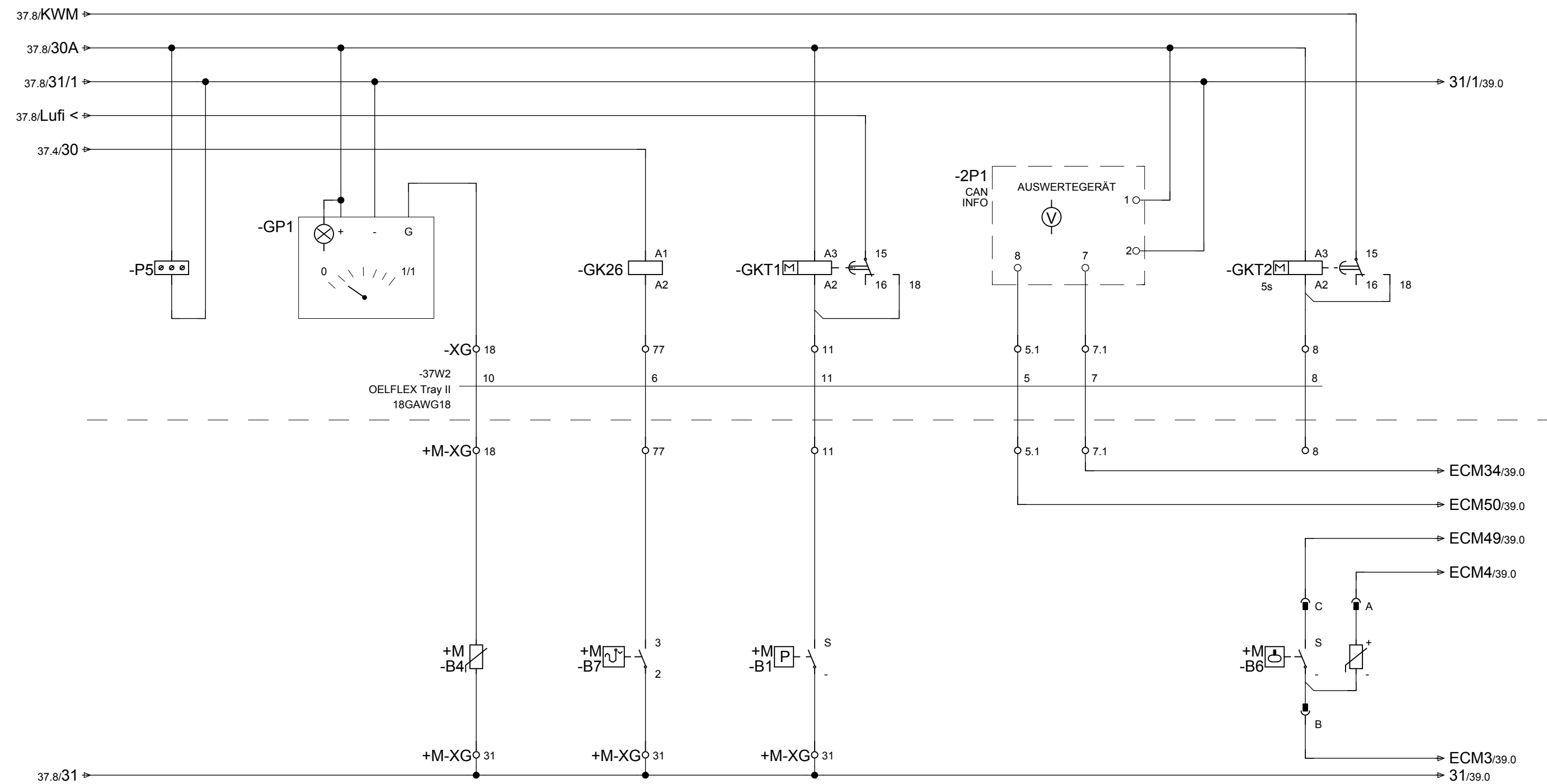

WAGO 788-312  
 14 ↗ 11 31.8  
 12 ↘ 24  
 22 ↘ 21

3RP15 25-2AP30  
 18 ↗ 16.5  
 15 ↘

3RP15 25-2AP30  
 18 ↗ 16.8  
 15 ↘

OPERATING HOUR METER	FUEL LEVEL	FUEL LEVEL	TEMPERATURE INDICATION 2: 100°C	AIR FILTER PLUGGES	OIL PRESSURE	TEMPERATURE	COOLING WATER LOW LEVEL
BETRIEBSSTUNDENZAehler	TANKINHAlt	TANKINHAlt	TEMPERATUR-ANZEIGE 2: 100°C	LUFTFILTER VERSCHMUTZT	OELDRUCK	TEMPERATUR	KUEHLWASSER-MANGEL

DATE	18.Apr.2012	KLEEMANN GMBH				BETRIEBSINSTRUMENTE/ OPERATIONAL INSTRUMENTS	KLEEMANN SERIES	K007	= 100	+
EDITED	JHE	MOBICAT MC 120 Z US					KLEEMANN MATERIAL NO	M20000111_01	CAE-SYSTEM: EPLAN 5.70	PG. 38
CONTR.	D. MALLKOWSKY	ORIGIN	REP.F.	REP.T.				PG. 41		

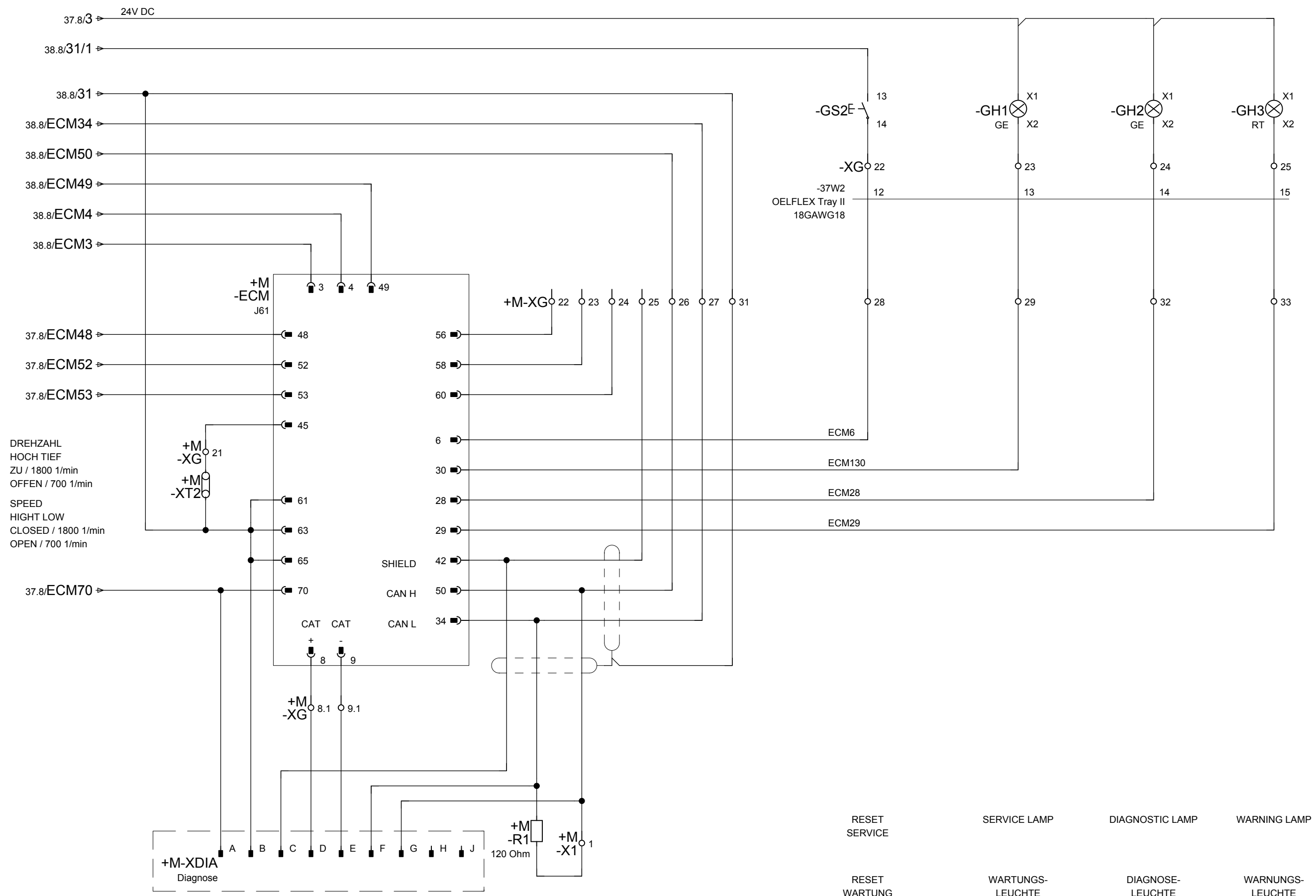

RESET SERVICE	SERVICE LAMP	DIAGNOSTIC LAMP	WARNING LAMP
RESET WARTUNG	WARTUNGS-LEUCHTE	DIAGNOSE-LEUCHTE	WARNUNGS-LEUCHTE

DATE	18.Apr.2012	KLEEMANN GMBH			BETRIEBSINSTRUMENTE/ OPERATIONAL INSTRUMENTS	KLEEMANN SERIES	K007	= 100	+
EDITED	JHE	MOBICAT MC 120 Z US				KLEEMANN MATERIAL NO	M20000111_01	CAE-SYSTEM: EPLAN 5.70	PG. 39
CONTR.	D. MALLKOWSKY	ORIGIN	REP.F.	REP.T.				PG. 41	

0	1	2	3	4	5	6	7	8	9

			DATE	18.Apr.2012	KLEEMANN GMBH			 	RESERVE/ SPARE	KLEEMANN SERIES	K007	= 100	+
			EDITED	JHE	MOBICAT MC 120 Z US					KLEEMANN MATERIAL NO	M20000111_01	CAE-SYSTEM: EPLAN 5.70	PG. 40
MODIFICAT.	DATE	NAME	NORM	DIN	ORIGIN	REP.F.	REP.T.						PG. 41

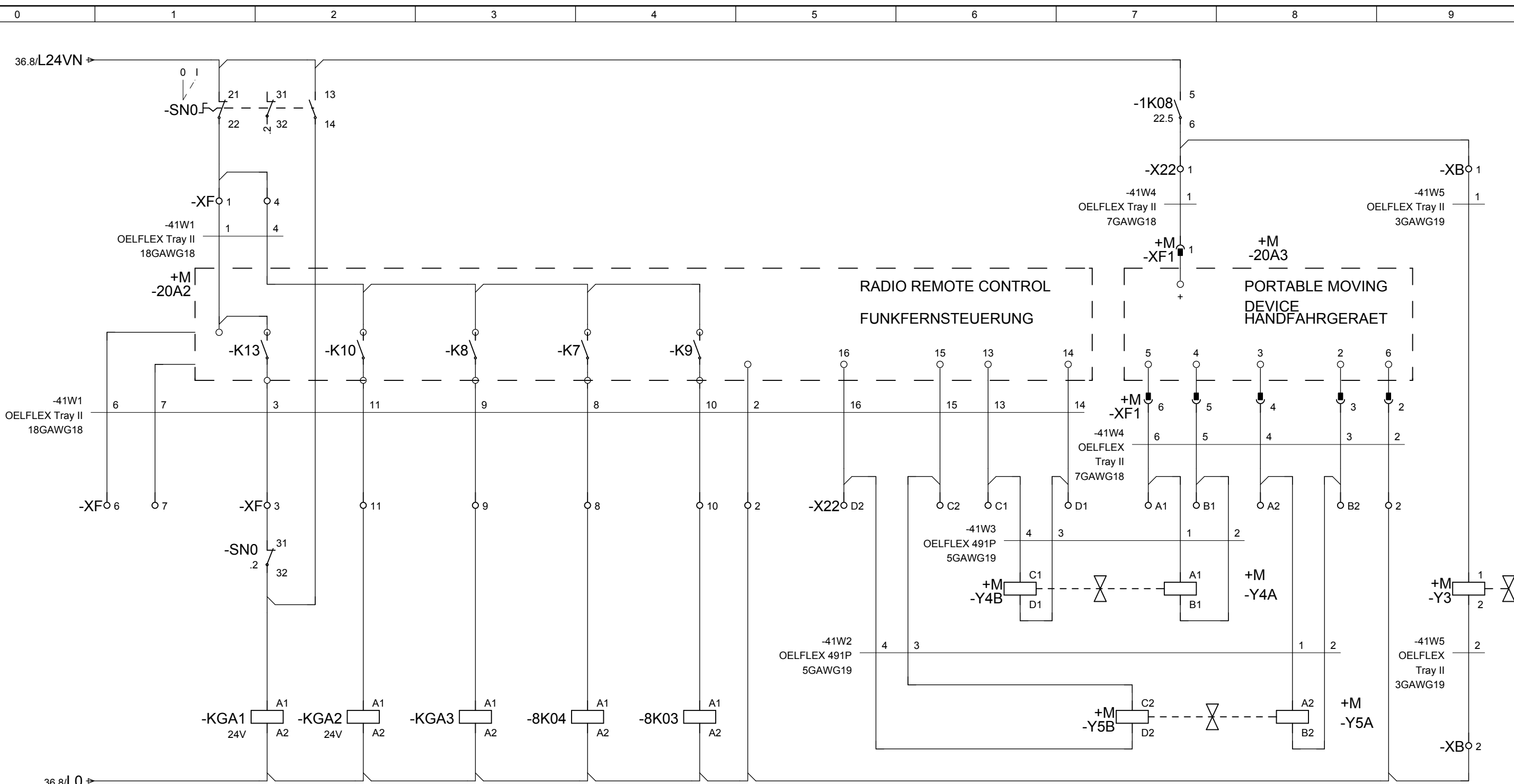

SIE 3RH11 22-2BB40	WAGO 788-312	WAGO 788-312	WAGO 788-312	WAGO 788-312
13 → 14 6.5 21 → 22 31 → 32 43 → 44 6.6	14 → 11 26.5 12 → 11 26.5 24 → 21	14 → 11 26.6 12 → 11 26.6 24 → 21	14 → 11 26.7 12 → 11 26.7 24 → 21	14 → 11 26.8 12 → 11 26.8 24 → 21

INSTALLATION OFF (RADIO) ANLAGE AUS (FUNK)	VIBRATING CHUTE + SCREEN ON(REMOTE) RINNE + SIEB EIN (FUNK)	VIBRATING CHUTE + SCREEN OFF(REMOTE) RINNE + SIEB AUS (FUNK)	VIBRATING CHUTE SLOWER (RADIO) RINNE LANGSAMER (FUNK)	VIBRATING CHUTE FASTER (RADIO) RINNE SCHNELLER (FUNK)	RUN CHAIN LEFT (REMOTE) FAHREN KETTE LINKS (FUNK)	RUN CHAIN RIGHT (REMOTE) FAHREN KETTE RECHTS (FUNK)	RUN CHAIN RIGHT (MANUAL) FAHREN KETTE RECHTS (HAND)	RUN CHAIN LEFT (MANUAL) FAHREN KETTE LINKS (HAND)	BRACKE VALVE BREMSVENTIL
---	--	---	--	--	--	--	--	--	-----------------------------



# TERMINAL- /PLUG STRIP OVERVIEW

TPSPST2 31.03.2003

Terminal strip and connector design	Text in terminal and connector strip definition	Terminals / plugs					Graphics page of the terminal strip
		first	Last	Total PE	Total N	Total number	
-X0	KLEMMENLEISTE -X0/TERMINAL STRIP -X0	1	20	0	0	20	=KLE/10
-X1	KLEMMLEISTE -X1/ TERMINAL STRIP -X1	PE	PE	10	2	37	=KLE/11
-X3	KLEMMENLEISTE -X3/TERMINAL STRIP -X3	1	14	0	0	14	=KLE/13
-X5	KLEMMLEISTE -X5/ TERMINAL STRIP -X5	1	12	0	0	12	=KLE/14
-X6	KLEMMLEISTE -X6/ TERMINAL STRIP -X6	1	4	0	0	4	=KLE/16
-X8	KLEMMENLEISTE -X8/ TERMINAL STRIP -X8	PE	6	2	0	8	=KLE/17
-X00	KLEMMENLEISTE -X00/TERMINAL STRIP -X00	1	N115	0	2	34	=KLE/18
-X22	KLEMMLEISTE -X22/ TERMINAL STRIP -X22	1	D2	0	0	10	=KLE/20
-XB	KLEMMENLEISTE -XB/ TERMINAL STRIP -XB	1	2	0	0	2	=KLE/21
-XF	KLEMMLEISTE -XF/ TERMINAL STRIP -XF	1	11	0	0	10	=KLE/22
-XG	KLEMMENLEISTE -XG/ TERMINAL STRIP -XG	3	77	0	0	17	=KLE/23
-XK	KLEMMENLEISTE -XK/ TERMINAL STRIP -XK	1	2	0	0	4	=KLE/24
-XLS	KLEMMLEISTE -XLS TERMINAL STRIP -XLS	1	4	0	0	4	=KLE/25
-XT	KLEMMLEISTE -XT/ TERMINAL STRIP -XT	1	5	0	0	5	=KLE/26
-0X0	KLEMMLEISTE -0X0/ TERMINAL STRIP -0X0	PE	2	1	0	3	=KLE/27
-0X06	KLEMMLEISTE -0X06/TERMINAL STRIP -0X06	PE	2	1	0	3	=KLE/28
-0X07	KLEMMENLEISTE -0X07/ TERMINAL STRIP -0X07	PE	2	1	0	3	=KLE/29
+M-XG	KLEMMENLEISTE +M-XG/ TERMINAL STRIP +M-XG	3	50	0	0	34	=KLE/30

# TERMINAL- /PLUG STRIP OVERVIEW

TPSPST2 31.03.2003

Terminal strip and connector design	Text in terminal and connector strip definition	Terminals / plugs					Graphics page of the terminal strip
		first	Last	Total PE	Total N	Total number	
-XOUT	STECKER -XOUT/ PLUG -XOUT	1	PE	0	0	18	=KLE/32
-3X2	STECKER -3X2/ PLUG -3X2	1	PE	0	0	5	=KLE/33
-4X1	STECKER -4X1/ PLUG -4X1	1	PE	1	0	8	=KLE/34
-4X2	STECKER -4X2/ PLUG -4X2	1	PE	0	0	5	=KLE/35
+M-XF1	STECKER +M-XF1 PLUG +M-XF1	1	6	0	0	6	=KLE/36
+M-XS2	STECKER +M-XS2/ PLUG +M-XS2	1	4	0	0	4	=KLE/37
+M-XS5	STECKER +M-XS5/ PLUG +M-XS5	1	4	0	0	4	=KLE/38
+M-6X1	STECKER +M-6X1/ PLUG +M-6X1	1	PE	1	0	4	=KLE/39



# TERMINAL STRIP/PLUG

## -X1

FUNCTION TEXT	CABLE DESIGNATION/TYP	-12W1 OELFLEX Tray II	-11W5 OELFLEX Tray II	-11W3 OELFLEX Tray II	-10W2 OELFLEX Tray II	-12W3 OELFLEX Tray II	-10W1 OELFLEX Tray II	DESIGNATION OF EXTERNAL DESTINATION	CONNECTION	NO.	BRIDGE	DESIGNATION OF INTERNAL DESTINATION	CONNECTION	PAGE/PATH
											FIXED	INTERNAL WIRING	PLC DESIGNATION	
MAGNETIC BELT 2	4G						PE	=100+M-2M1	PE	PE		=100-PE		=100/10.2
=							1	=100+M-2M1	U	1		=100-2KC1	2	=100/10.1
=							2	=100+M-2M1	V	2		=100-2KC1	4	=100/10.1
=							3	=100+M-2M1	W	3		=100-2KC1	6	=100/10.1
MAGNET							PE	=100+M-2Y1	PE	PE		=100-PE		=100/10.5
=							1	=100+M-2Y1	L1	4		=100-2KC3	2	=100/10.4
=							2	=100+M-2Y1	L2	5		=100-2KC3	4	=100/10.4
=							3	=100+M-2Y1	L3	6		=100-2KC3	6	=100/10.4
=							4	=100+M-2Y1	N	7		=100-0X1	N	=100/10.4
VIBRATING CHUTE/CRUSHER 5							PE	=100+M-5M1	PE	PE		=100-PE		=100/11.4
=							1	=100+M-5M1	U	8		=100-5KC1	2	=100/11.4
=							2	=100+M-5M1	V	9		=100-5KC1	4	=100/11.4
=							3	=100+M-5M1	W	10		=100-5KC1	6	=100/11.4
=							PE	=100+M-5M2	PE	PE		=100-PE		=100/11.7
=							1	=100+M-5M2	U	11		=100-5KC2	2	=100/11.7
=							2	=100+M-5M2	V	12		=100-5KC2	4	=100/11.7
=							3	=100+M-5M2	W	13		=100-5KC2	6	=100/11.7
CONVEYOR BELT 6		PE						+M-6X1	PE	PE		=100-PE		=100/12.2
=							PE	=100+M-6X2	PE	PE				=100/12.2
=							1	+M-6X1	1	14		=100-6KC1	2	=100/12.1
=							1	=100+M-6X2	1	14				=100/12.1
=							2	+M-6X1	2	15		=100-6KC1	4	=100/12.1
=							2	=100+M-6X2	2	15				=100/12.1

DATE	18.Apr.2012	KLEEMANN GMBH			KLEMMLEISTE -X1/ TERMINAL STRIP -X1	KLEEMANN SERIES	K007	= KLE	+
EDITED	JHE	MOBICAT MC 120 Z US				KLEEMANN MATERIAL NO	M20000111_01	CAE-SYSTEM: EPLAN 5.70	PG. 11
CONTR.	D. MALLKOWSKY								PG. 39
MODIFICAT.	DATE	NAME	NORM	DIN	ORIGIN	REP.F.	REP.T.		

# TERMINAL STRIP/PLUG

-X1

FUNCTION TEXT	CABLE DESIGNATION/TYP	-13W3 OELFLEX Tray II	4G	-13W2 OELFLEX Tray II	3G	-13W1 OELFLEX Tray II	4G	-12W4 OELFLEX Tray II	4G	-12W3 OELFLEX Tray II	4G	-12W1 OELFLEX Tray II	4G	DESIGNATION OF EXTERNAL DESTINATION	CONNECTION	NO.	BRIDGE		DESIGNATION OF INTERNAL DESTINATION	CONNECTION	CABLE DESIGNATION/TYP	PAGE/PATH	
																	FIXED	INTERNAL WIRING					PLC DESIGNATION
CONVEYOR BELT 6												3	+M-6X1	3	16			=100-6KC1	6		=100/12.1		
VIBRATING SCREEN 7												3	=100+M-6X2	3	16			=100-6KC1	6		=100/12.1		
=													PE	PE	17			=100-PE			=100/12.4		
=													1	U1	17			=100-7KC1	2		=100/12.4		
=													2	V1	18			=100-7KC1	4		=100/12.4		
=													3	W1	19			=100-7KC1	6		=100/12.4		
HYDRAULIC 9							PE							=100+M-9M1	PE	PE		=100-PE			=100/13.2		
=							1							=100+M-9M1	U	20		=100-9KC1	2		=100/13.1		
=							2							=100+M-9M1	V	21		=100-9KC1	4		=100/13.1		
=							3							=100+M-9M1	W	22		=100-9KC1	6		=100/13.1		
WATERPUMP 10														=100+M-WP	PE	PE		=100-PE			=100/13.4		
=							1							=100+M-WP	L1	23		=100-10KC1	2		=100/13.3		
=							2							=100+M-WP	N	24	●				=100/13.4		
EXCESS PRESSURE FAN 1														=100+M-13M1	PE	PE		=100-PE			=100/13.6		
=														=100+M-13M1	U	25		=100-13Q1	2		=100/13.6		
=														=100+M-13M1	V	26		=100-13Q1	4		=100/13.6		
=														=100+M-13M1	W	27		=100-13Q1	6		=100/13.6		
CRUSHER 1														=100+M-1M1	PE	PE		=100-PE			=100/8.4		

DATE	18.Apr.2012	KLEEMANN GMBH		 	KLEMMLEISTE -X1/ TERMINAL STRIP -X1	KLEEMANN SERIES	K007	= KLE	+
EDITED	JHE	MOBICAT MC 120 Z US			REP.T.		KLEEMANN MATERIAL NO	M20000111_01	CAE-SYSTEM: EPLAN 5.70
CONTR.	D. MALLKOWSKY	ORIGIN	REP.F.						PG. 39
MODIFICAT.	DATE	NAME	NORM	DIN					

# TERMINAL STRIP/PLUG

-X3

0	1		2		3		4		5		6		7		8		9		
FUNCTION TEXT	CABLE DESIGNATION/TYP								DESIGNATION OF EXTERNAL DESTINATION	CONNECTION	NO.	BRIDGE		DESIGNATION OF INTERNAL DESTINATION	CONNECTION			PAGE/PATH	
												FIXED	INTERNAL WIRING						PLC DESIGNATION
EMERGENCY STOP SWITCHGEAR									-4X2	2	1	●							=100/6.5
=									=100-KGA1	13	2	●							=100/6.5
=									-4X2	4	3	●							=100/6.6
=									=100-KGA1	43	4	●							=100/6.6
SPARE											5					=100-S5.2	13		=100/29.4
=											6					=100-8S	13		
=											7			E5.3		=100-10H1	X2		=100/35.6
=											8			E5.4		=100-LS1	10		
=											9			E5.5		-A0_5	13		=100/29.4
											10			E5.6		-A0_5	14		=100/29.5
VIBRATING FEEDER 8 +											11			E5.7		-A0_5	15		=100/29.6
											12			E5.6		=100-8S	16		=100/29.7
VIBRATING FEEDER 8 -											13			E5.7		-A0_5	17		=100/29.8
											14			E5.7		=100-8S	24		
SPARE											12			A11.5		-A0_6	33		=100/35.6
=											13			A11.6		-A0_6	34		=100/35.7
=											14			A11.7		-A0_6	35		=100/35.8

# TERMINAL STRIP/PLUG

-X5

FUNCTION TEXT	CABLE DESIGNATION/TYP	-14W2 OELFLEX Tray II	3G1.5	-12W5 OELFLEX Tray II	3G	-11W6 OELFLEX Tray II	3G	-11W4 OELFLEX Tray II	3G	-08W8 OELFLEX Tray II	3G	DESIGNATION OF EXTERNAL DESTINATION	CONNECTION	NO.	BRIDGE	INTERNAL WIRING	PLC DESIGNATION	DESIGNATION OF INTERNAL DESTINATION	CONNECTION	CABLE DESIGNATION/TYP	PAGE/PATH
MOTOR PROTECTION RELAY										1		=100+M-1R1		1				=100-1K0	T1		=100/8.6
=										2		=100+M-1R1		2				=100-1K0	T2		=100/8.6
VIBRATING CHUTE/CRUSHER 5								1				=100+M-5M1		3				=100-5K0	T1		=100/11.5
=								2				=100+M-5M1		4				=100-5K0	T2		=100/11.5
=									1			=100+M-5M2		5				=100-5K0.1	T1		=100/11.8
=									2			=100+M-5M2		6				=100-5K0.1	T2		=100/11.8
VIBRATING SCREEN 7												=100+M-7M1		7				=100-7K0	T1		=100/12.5
=									2			=100+M-7M1		8				=100-7K0	T2		=100/12.5
VIBRATING FEEDER 8 DRIVE LEFT												=100+M-8M1		9				=100-8K0	T1		=100/14.2
=												=100+M-8M1		10	●						=100/14.3

DATE	18.Apr.2012	KLEEMANN GMBH	 	KLEMMLEISTE -X5/ TERMINAL STRIP -X5	KLEEMANN SERIES	K007	= KLE	+
EDITED	JHE	MOBICAT MC 120 Z US		KLEEMANN MATERIAL NO	M20000111_01	CAE-SYSTEM: EPLAN 5.70	PG.	14
CONTR.	D. MALLKOWSKY	ORIGIN	REP.F.	REP.T.		PG.	39	

TERMINAL STRIP/PLUG  
-X5

FUNCTION TEXT	CABLE DESIGNATION/TYPE	2	3	4	-14W4 OELFLEX Tray II	3G1.5	DESIGNATION OF EXTERNAL DESTINATION	CONNECTION	NO.	BRIDGE		DESIGNATION OF INTERNAL DESTINATION	CONNECTION	CABLE DESIGNATION/TYPE	PAGE/PATH
										FIXED	INTERNAL WIRING				
VIBRATING FEEDER 8 DRIVE RIGHT							1 =100+M-8M2		11	•					=100/14.4
=							2 =100+M-8M2		12			=100-8K0	T2		=100/14.4

DATE	18.Apr.2012			
EDITED	JHE			
CONTR.	D. MALLKOWSKY			
MODIFICAT.	DATE	NAME	NORM	DIN

KLEEMANN GMBH	ORIGIN
MOBICAT MC 120 Z US	REP.F.



KLEMMLEISTE -X5/ TERMINAL STRIP -X5	REP.T.
--	--------

KLEEMANN SERIES	K007
KLEEMANN MATERIAL NO	M20000111_01

= KLE	+
CAE-SYSTEM: EPLAN 5.70	PG. 15 PG. 39



# TERMINAL STRIP/PLUG

-X6

FUNCTION TEXT	CABLE DESIGNATION/TYP										DESIGNATION OF EXTERNAL DESTINATION	CONNECTION	NO.	BRIDGE		PLC DESIGNATION	DESIGNATION OF INTERNAL DESTINATION	CONNECTION			CABLE DESIGNATION/TYP	PAGE/PATH
														FIXED	INTERNAL WIRING							
HOOTER													1				=100-00K2	14				=100/7.7
=													2				-XK	2				=100/7.7
FLASHING LIGHT													3				=100-00K3	14				=100/7.8
=													4				=100-1K0	A2				=100/7.8



# TERMINAL STRIP/PLUG

-X00

FUNCTION TEXT	CABLE DESIGNATION/TYP	DESIGNATION OF EXTERNAL DESTINATION	CONNECTION	NO.	BRIDGE		DESIGNATION OF INTERNAL DESTINATION	CONNECTION	PAGE/ PATH
					FIXED	INTERNAL WIRING			
CONTROL VOLTAGE ON		=100-D1	A1	1	●		=100-0K1	4	=100/7.4
		=100-SC	13	1	●		=100-8K0	A1	=100/17.1
		=100-A0_OP-X1	L+	1	●				=100/17.2
		=100-A0_CPU	1	1	●				=100/17.2
		-A0_2	1	1	●	L+			=100/17.2
		-A0_2	1	1	●	L+			=100/17.3
		-A0_3	1	1	●	L+	-A0_2	2	=100/17.4
INSTALLATION ON		=100-S0.0	13	1	●		=100-GK61	11	=100/24.1
CONVEYOR BELT 4 ON/OFF		=100-4S1	13	1	●		=100-2S2	13	=100/25.1
SUPPLY 24V AFTER EMERGENCY STOP		=100-K0.1	A2	2	●		=100-D1	A2	=100/7.1
=		=100-TK1		2	●				=100/7.2
CONTROL VOLTAGE ON		=100-0K1	A2	2	●		-XK	2	=100/7.3
VIBRATING FEEDER 8 DRIVE RIGHT		=100-8A1	T1	2	●		=100-7K0	A2	=100/14.7
		=100-A_FW-X1	0V	2	●		=100-8K0	A2	=100/17.1
		=100-A0_OP-X1	M	2	●		=100-8K0	A2	=100/17.2
		=100-A0_CPU	2	2	●				=100/17.2
		-A0_2	18	2	●	M			=100/17.3
		-A0_2	18	2	●	M			=100/17.3
		-A0_3	18	2	●	M			=100/17.4
		-A0_4	18	2	●	M1			=100/17.4
		-A0_4	36	2	●	M2			=100/17.5
		-A0_5	18	2	●	M1			=100/17.5

DATE	18.Apr.2012	KLEEMANN GMBH		 	KLEMMENLEISTE -X00/ TERMINAL STRIP -X00	KLEEMANN SERIES	K007	= KLE	+
EDITED	JHE	MOBICAT MC 120 Z US				KLEEMANN MATERIAL NO	M20000111_01	CAE-SYSTEM: EPLAN 5.70	PG.
CONTR.	D. MALLKOWSKY	ORIGIN	REP.F.	REP.T.				PG.	39

# TERMINAL STRIP/PLUG

-X00

FUNCTION TEXT	CABLE DESIGNATION/TYP	DESIGNATION OF EXTERNAL DESTINATION	CONNECTION	NO.	BRIDGE		DESIGNATION OF INTERNAL DESTINATION	CONNECTION	CABLE DESIGNATION/TYP	PAGE/PATH
					FIXED	INTERNAL WIRING				
		-A0_5	36	2	●		M2			=100/17.6
		-A0_6	18	2	●		1M			=100/17.6
		-A0_6	36	2	●		2M			=100/17.7
SET VALUE FREQUENCY CONVERTER VIBRATING FEEDER 8		-A0_2	14	2	●		=100-1K1	A2		=100/19.3
SUPPLY 24V AFTER EMERGENCY STOP		-A0_2	9	3	●		=100-K0.1	14		=100/7.2
=				3	●					=100/7.2
		-A0_6	1	3	●		1L+			=100/17.6
		-A0_6	19	3	●		2L+			=100/17.6
TOTAL FAULT CURRENT PROTECTION		=100-PE	PEN	N	●		=100-0F01	8		=100/1.6
=				N	●		=100-0X1	N		=100/1.6
SOCKET 15A/115V				L115	●		=100-0F1.3	1		=100/5.5
=		=100-1K01	A1	L115	●					=100/5.5
=				N115	●		=100-0T1	V2		=100/5.5
=		=100-1K01	A2	N115	●					=100/5.5

DATE	18.Apr.2012	KLEEMANN GMBH		 	KLEEMANN SERIES	K007	= KLE	+
EDITED	JHE	MOBICAT MC 120 Z US			KLEMMENLEISTE -X00/ TERMINAL STRIP -X00	KLEEMANN MATERIAL NO	M20000111_01	CAE-SYSTEM: EPLAN 5.70
CONTR.	D. MALLKOWSKY	ORIGIN	REP.F.	REP.T.				PG. 39

# TERMINAL STRIP/PLUG

## -X22

FUNCTION TEXT	CABLE DESIGNATION/TYPE	5G	18G	5G	7G	DESIGNATION OF EXTERNAL DESTINATION	CONNECTION	NO.	FIXED	BRIDGE	INTERNAL WIRING	PLC DESIGNATION	DESIGNATION OF INTERNAL DESTINATION	CONNECTION	PAGE/PATH
EINSPEISUNG 24V DC		OELFLEX 491P				+M-XF1	1	1					=100-1K08	6	=100/41.7
EINSPEISUNG 0V DC						+M-XF1	2	2					-XB	1	
RUN CHAIN RIGHT (MANUAL)						+M-XF1	6	6						2	=100/41.9
RUN CHAIN LEFT (MANUAL)						+M-XF1	4	A1							=100/41.7
RUN CHAIN RIGHT (MANUAL)						+M-XF1	4	A2							=100/41.8
RUN CHAIN LEFT (MANUAL)						+M-XF1	5	B1							=100/41.7
RUN CHAIN RIGHT (REMOTE)						+M-XF1	3	B2							=100/41.8
RUN CHAIN LEFT (REMOTE)						+M-XF1	13	C1							=100/41.6
RUN CHAIN RIGHT (REMOTE)						+M-XF1	15	C2							=100/41.6
RUN CHAIN LEFT (REMOTE)						+M-XF1	14	D1							=100/41.7
RUN CHAIN RIGHT (REMOTE)						+M-XF1	16	D2							=100/41.5

MODIFICAT.	DATE	NAME	NORM	DIN	ORIGIN	REP.F.	REP.T.									
		DATE		18.Apr.2012		KLEEMANN GMBH					KLEEMANN SERIES		K007		= KLE	
		EDITED		JHE		MOBICAT MC 120 Z US			KLEMMLEISTE -X22/ TERMINAL STRIP -X22		KLEEMANN MATERIAL NO		M20000111_01		CAE-SYSTEM: EPLAN 5.70	
		CONTR.		D. MALLKOWSKY											PG. 20	
															PG. 39	



0	1	2	3	4	5	6	7	8	9					
FUNCTION TEXT				CABLE DESIGNATION/TYPE	<h1>TERMINAL STRIP/PLUG</h1> <h2>-XF</h2>					CABLE DESIGNATION/TYPE	PAGE/PATH			
					DESIGNATION OF EXTERNAL DESTINATION	CONNECTION	NO.	BRIDGE				DESIGNATION OF INTERNAL DESTINATION	CONNECTION	
								FIXED	INTERNAL WIRING					
VIBRATING CHUTE FASTER (RADIO)				-41W1 OELFLEX Tray II	18G	1	=100+M-20A2		1		=100-SN0	22	=100/41.1	
INSTALLATION OFF (RADIO)						2	=100+M-20A2		2	•		=100-8K03	A2	=100/41.5
=						3	=100+M-20A2		3			-X22	2	=100/41.2
						4	=100+M-20A2		4			=100-SN0	31	=100/41.2
						6	=100+M-20A2		6					=100/41.1
VIBRATING CHUTE SLOWER (RADIO)						7	=100+M-20A2		7					=100/41.1
VIBRATING CHUTE + SCREEN OFF(REMOTE)						8	=100+M-20A2		8			=100-8K04	A1	=100/41.4
VIBRATING CHUTE FASTER (RADIO)						9	=100+M-20A2		9			=100-KGA3	A1	=100/41.3
VIBRATING CHUTE + SCREEN ON(REMOTE)						10	=100+M-20A2		10			=100-8K03	A1	=100/41.4
						11	=100+M-20A2		11	•		=100-KGA2	A1	=100/41.2

# TERMINAL STRIP/PLUG

## -XG

FUNCTION TEXT	CABLE DESIGNATION/TYP	4G	18G	DESIGNATION OF EXTERNAL DESTINATION	CONNECTION	NO.	BRIDGE	INTERNAL WIRING	PLC DESIGNATION	DESIGNATION OF INTERNAL DESTINATION	CONNECTION	CABLE DESIGNATION/TYP	PAGE/PATH
RELEASE				+M-XG	3	3				=100-GA1	3		=100/37.7
OIL PRESSURE				+M-XG	5.1	5.1				=100-2P1	8		=100/38.6
TEMPERATURE				+M-XG	7.1	7.1				=100-2P1	7		=100/38.6
COOLING WATER LOW LEVEL				+M-XG	8	8				=100-GKT2	A2		=100/38.8
AIR FILTER PLUGGES				+M-XG	11	11				=100-GKT1	A2		=100/38.5
FUEL LEVEL				+M-XG	18	18				=100-GP1	G		=100/38.3
RESET SERVICE				+M-XG	28	22				=100-GS2	14		=100/39.6
SERVICE LAMP				+M-XG	29	23				=100-GH1	X2		=100/39.7
DIAGNOSTIC LAMP				+M-XG	32	24				=100-GH2	X2		=100/39.7
WARNING LAMP				+M-XG	33	25				=100-GH3	X2		=100/39.8
SUPPLY 24V		1		+M-XG	30	30				=100-GF1	A2		=100/37.0
SUPPLY 0V		2		+M-XG	31	31	●			=100-0F06	1		=100/37.1
=						31	●			=100-GK1	A2		=100/37.1
=						31	●			-0X06	2		=100/37.1
START				+M-XG	50	50				=100-GA1	6		=100/37.1
=						61				=100-GK6	A2		=100/37.4
TEMPERATURE INDICATION 2: 100°C				+M-XG	77	77				=100-GK6	14		=100/37.4
										=100-GA1	4		=100/37.6
				+M-XG						=100-GK26	A2		=100/38.4

DATE	18.Apr.2012	KLEEMANN GMBH			KLEMMENLEISTE -XG/ TERMINAL STRIP -XG	KLEEMANN SERIES	K007	= KLE	+
EDITED	JHE	MOBICAT MC 120 Z US				KLEEMANN MATERIAL NO	M20000111_01	CAE-SYSTEM: EPLAN 5.70	PG. 23
CONTR.	D. MALLKOWSKY								PG. 39
MODIFICAT.	DATE	NAME	NORM	DIN	ORIGIN	REP.F.	REP.T.		



# TERMINAL STRIP/PLUG

-XK

FUNCTION TEXT	CABLE DESIGNATION/TYPE							-07W2 OELFLEX Tray II 3G	-07W1 OELFLEX Tray II 3G	DESIGNATION OF EXTERNAL DESTINATION	CONNECTION	NO.	BRIDGE		DESIGNATION OF INTERNAL DESTINATION	CONNECTION			CABLE DESIGNATION/TYPE	PAGE/ PATH		
													INTERNAL WIRING	PLC DESIG- NATION								
																					F I X E D	
COUPLING									1	=100+M-Y9	A1	1	●		=100-1K08	2				=100/7.5		
RUN WARNING								1		=100+M-1H2	A1	1	●								=100/7.6	
COUPLING									2	=100+M-Y9	A2	2	●		-X00	2					=100/7.5	
RUN WARNING								2		=100+M-1H2	A2	2	●		-X6	2					=100/7.6	

0	1	2	3	4	5	6	7	8	9							
FUNCTION TEXT	CABLE DESIGNATION/TYP					-36W1 UNITRONIC 3x0.5mm²	-36W2 UNITRONIC 3x0.5mm²	TERMINAL STRIP/PLUG -XLS						CABLE DESIGNATION/TYP	PAGE/ PATH	
								DESIGNATION OF EXTERNAL DESTINATION	CONNECTION	NO.	BRIDGE		DESIGNATION OF INTERNAL DESTINATION			CONNECTION
									F I X E D	INTERNAL WIRING	PLC DESIG- NATION					
LIGHT BARRIER CRUSHER							GN	=100+M-LT		7				=100-LS1	7	=100/36.3
=							BN	=100+M-LT		5				=100-LS1	5	=100/36.3
=						GN		=100+M-LR		6				=100-LS1	6	=100/36.2
=						BN		=100+M-LR		8				=100-LS1	8	=100/36.2

**TERMINAL STRIP/PLUG**

**-XT**

FUNCTION TEXT	CABLE DESIGNATION/TYP										BRIDGE				CABLE DESIGNATION/TYP	PAGE/ PATH			
											DESIGNATION OF EXTERNAL DESTINATION	CONNECTION	NO.	INTERNAL WIRING			DESIGNATION OF INTERNAL DESTINATION	CONNECTION	
														PLC DESIG- NATION					
TOTAL FAULT CURRENT PROTECTION							=100-0SS	13	1				=100-TS1	13		=100/1.7			
=							=100-TS1	14	2				=100-TS2	13		=100/1.7			
=							=100-TS2	14	3				=100-TS3	13		=100/1.7			
=							=100-TS3	14	4				=100-TS4	13		=100/1.7			
=							=100-TS4	14	5				=100-0SS	14		=100/1.7			

DATE	18.Apr.2012	KLEEMANN GMBH				KLEMMLEISTE -XT/ TERMINAL STRIP -XT	KLEEMANN SERIES	K007	= KLE	
CONTR.	D. MALLKOWSKY	MOBICAT MC 120 Z US					KLEEMANN MATERIAL NO	M20000111_01	CAE-SYSTEM: EPLAN 5.70	PG.
MODIFICAT.	DATE	NAME	NORM	DIN	ORIGIN	REP.F.	REP.T.		PG.	39

## TERMINAL STRIP/PLUG

-0X0

FUNCTION TEXT	CABLE DESIGNATION/TYP	C	2	3	4	5	6	7	8	9	CABLE DESIGNATION/TYP	PAGE/ PATH							
													DESIGNATION OF EXTERNAL DESTINATION	CONNECTION	NO.	BRIDGE		DESIGNATION OF INTERNAL DESTINATION	CONNECTION
																F I X E D	INTERNAL WIRING		
BELT WEIGHER																			
=																			
=																			

DATE	18.Apr.2012	KLEEMANN GMBH	 	KLEMMLEISTE -0X0/ TERMINAL STRIP -0X0	KLEEMANN SERIES	K007	= KLE	+
MODIFICAT.	DATE	NAME		REPLACEMENT	REP.T.	KLEEMANN MATERIAL NO	M20000111_01	CAE-SYSTEM: EPLAN 5.70

# TERMINAL STRIP/PLUG

-0X06

0	1	2	3	4	5	6	7	8	9								
FUNCTION TEXT	CABLE DESIGNATION/TYP															CABLE DESIGNATION/TYP	PAGE/ PATH
FIXED	INTERNAL WIRING	PLC DESIGNATION															
ILLUMINATION 1																	
=																	
=																	

KLEMMLEISTE -0X06/  
TERMINAL STRIP -0X06

KLEEMANN SERIES  
K007

KLEEMANN MATERIAL NO  
M20000111\_01

= KLE

+

PG. 28

PG. 39

FUNCTION TEXT		CABLE DESIGNATION/TYP	TERMINAL STRIP/PLUG -0X07												CABLE DESIGNATION/TYP	PAGE/ PATH
			5G	DESIGNATION OF EXTERNAL DESTINATION	CONNECTION	NO.	BRIDGE		PLC DESIGNATION	DESIGNATION OF INTERNAL DESTINATION	CONNECTION					
							F I X E D	INTERNAL WIRING								
ILLUMINATION 2						PE				=100-PE						=100/3.4
=				3 =100+M-E2	X1	1				=100-KX	24					=100/3.3
=				4 =100+M-E2	X2	2				-0X06	2					=100/3.3
										-0X0	2					

28 30

# TERMINAL STRIP/PLUG

+M-XG

FUNCTION TEXT	CABLE DESIGNATION/TYP																	CABLE DESIGNATION/TYP	PAGE/ PATH											
		TERMINAL STRIP/PLUG																												
		+M-XG																												
									-37W1 OELFLEX Tray II	4G					-37W2 OELFLEX Tray II	18G	DESIGNATION OF EXTERNAL DESTINATION	CONNECTION	NO.	BRIDGE		PLC DESIG- NATION	DESIGNATION OF INTERNAL DESTINATION	CONNECTION						
																				FIXED	INTERNAL WIRING									
RELEASE																	3	-XG	3				=100-K2	86						=100/37.7
START																	=100-XT1	2	3A				=100-K2	87						=100/37.6
=																			3A											=100/37.6
OIL PRESSURE																	5	-XG	5.1											=100/38.6
TEMPERATURE																	7	-XG	7.1											=100/38.6
COOLING WATER LOW LEVEL																	8	-XG	8											=100/38.8
																							-ECM	8						=100/39.2
																							-ECM	9						=100/39.2
AIR FILTER PLUGGES																	11	-XG	11				=100-B1	S						=100/38.5
FUEL LEVEL																	10	-XG	18				=100-B4							=100/38.3
																							-ECM	45						=100/39.1
																							-ECM	56						=100/39.3
																							-ECM	58						=100/39.4
																							-ECM	60						=100/39.4
																														=100/39.4
																							-X1	1						=100/39.4
																							-ECM	34						=100/39.4
																							=100-R1							=100/39.4
RESET SERVICE																	12	-XG	22				-ECM	6						=100/39.6
SERVICE LAMP																	13	-XG	23				-ECM	30						=100/39.7
SUPPLY 24V																	1	-XG	30				=100-F1	A1						=100/37.0

# TERMINAL STRIP/PLUG

## +M-XG

FUNCTION TEXT	CABLE DESIGNATION/TYP	18G	4G	DESIGNATION OF EXTERNAL DESTINATION	CONNECTION	NO.	BRIDGE	INTERNAL WIRING	PLC DESIGNATION	DESIGNATION OF INTERNAL DESTINATION	CONNECTION	PAGE/PATH	
SUPPLY 0V			2	-XG	31	31	F I X E D			=100-S1	14	=100/37.1	
=						31							=100/37.1
=						31							=100/37.1
RELEASE				=100-K1	85	31					=100-K2	85	=100/37.7
FUEL LEVEL				=100-B4		31							=100/38.3
TEMPERATURE INDICATION 2: 100°C				=100-B7	2	31							=100/38.4
AIR FILTER PLUGGES				=100-B1		31					=100-XT2	_2	=100/38.5
				=100-XT2		31					Schirm		=100/39.5
DIAGNOSTIC LAMP		14		-XG	24	32					-ECM	28	=100/39.7
WARNING LAMP		15		-XG	25	33					-ECM	29	=100/39.8
RELEASE				=100-F2	A1	34					-ECM	53	=100/37.7
=				-ECM	48	34					-ECM	52	=100/37.8
START			2	-XG	50	50					=100-K1	86	=100/37.4
TEMPERATURE INDICATION 2: 100°C		6		-XG	77	77				=100-B7	3	=100/38.4	

DATE	18.Apr.2012	KLEEMANN GMBH		KLEEMANN SERIES	K007	= KLE	+
EDITED	JHE	MOBICAT MC 120 Z US		KLEEMANN MATERIAL NO	M20000111_01	CAE-SYSTEM:	PG. 31
CONTR.	D. MALLKOWSKY			EPLAN 5.70			PG. 39
MODIFICAT.	DATE	NAME	NORM	DIN	ORIGIN	REP.F.	REP.T.







# TERMINAL STRIP/PLUG -4X1

FUNCTION TEXT	CABLE DESIGNATION/TYP	3G OELFLEX Tray II	4G -11W1 OELFLEX Tray II	DESIGNATION OF EXTERNAL DESTINATION	CONNECTION	NO.	BRIDGE		DESIGNATION OF INTERNAL DESTINATION	CONNECTION	PAGE/PATH
							FIXED	INTERNAL WIRING			
								PLC DESIGNATION			
CONVEYOR BELT 4				=100+M-4M1	U	1			=100-4KC1	2	=100/11.1
=				=100+M-4M1	V	2			=100-4KC1	4	=100/11.1
=				=100+M-4M1	W	3			=100-4KC1	6	=100/11.1
=						4					
=				=100+M-4M1		5			=100-4K0	T1	=100/11.2
=				=100+M-4M1		6			=100-4K0	T2	=100/11.2
=					PE	PE					
=				=100+M-4M1	PE	PE			=100-PE		=100/11.2

# TERMINAL STRIP/PLUG

-4X2

FUNCTION TEXT	CABLE DESIGNATION/TYP								5G	-06W8 OELFLEX Tray II	DESIGNATION OF EXTERNAL DESTINATION	CONNECTION	NO.	BRIDGE		DESIGNATION OF INTERNAL DESTINATION	CONNECTION	CABLE DESIGNATION/TYP	PAGE/PATH	
														FIXED	INTERNAL WIRING					PLC DESIGNATION
EMERGENCY STOP SWITCHGEAR											=100+M-0S08	22	1			-3X2	2		=100/6.5	
=											=100+M-0S08	21	2			-X3	1		=100/6.5	
=											=100+M-0S08	12	3			-3X2	4		=100/6.6	
=											=100+M-0S08	11	4			-X3	3		=100/6.6	
													PE							

DATE	18.Apr.2012	KLEEMANN GMBH		 	STECKER -4X2/ PLUG -4X2	KLEEMANN SERIES	K007	= KLE	+
EDITED	JHE	MOBICAT MC 120 Z US					KLEEMANN MATERIAL NO	M20000111_01	CAE-SYSTEM: EPLAN 5.70
CONTR.	D. MALLKOWSKY	ORIGIN	REP.F.	REP.T.					PG. 39
MODIFICAT.	DATE	NAME	NORM	DIN					

## TERMINAL STRIP/PLUG

+M-XF1

FUNCTION TEXT	CABLE DESIGNATION/TYP	2	3	4	5	6	7	8	9				
							BRIDGE					CABLE DESIGNATION/TYP	PAGE/PATH
							DESIGNATION OF EXTERNAL DESTINATION	CONNECTION					
EINSPEISUNG 24V DC						=100-20A3	+				1		=100/41.7
EINSPEISUNG 0V DC						=100-20A3	6				2		=100/41.9
RUN CHAIN LEFT (MANUAL)						=100-20A3	2				3		=100/41.8
=						=100-20A3	3				4		=100/41.8
RUN CHAIN RIGHT (MANUAL)						=100-20A3	4				5		=100/41.7
=						=100-20A3	5				6		=100/41.7

DATE	18.Apr.2012	KLEEMANN GMBH		STECKER +M-XF1 PLUG +M-XF1	KLEEMANN SERIES K007	= KLE	+
EDITED	JHE	MOBICAT MC 120 Z US			KLEEMANN MATERIAL NO M20000111_01	CAE-SYSTEM: EPLAN 5.70	PG. 36
CONTR.	D. MALLKOWSKY						PG. 39
MODIFICAT.	DATE	NAME	NORM	DIN	ORIGIN	REP.F.	REP.T.



# TERMINAL STRIP/PLUG

+M-XS5

FUNCTION TEXT	CABLE DESIGNATION/TYP									-06W15 OELFLEX Tray II	5G	DESIGNATION OF EXTERNAL DESTINATION	CONNECTION	NO.	BRIDGE		DESIGNATION OF INTERNAL DESTINATION	CONNECTION	-06W5 OELFLEX Tray II	5G	CABLE DESIGNATION/TYP	PAGE/ PATH	
															FIXED	INTERNAL WIRING							PLC DESIGNATION
E-STOP PUSH-BUTTON												=100-0S05	22	1			-X0	11				=100/6.2	
=												=100-0S05	21	2			-X0	9				=100/6.2	
=												=100-0S05	12	3			-X0	12				=100/6.2	
=												=100-0S05	11	4			-X0	10				=100/6.2	

DATE	18.Apr.2012	KLEEMANN GMBH		 	STECKER +M-XS5/ PLUG +M-XS5	KLEEMANN SERIES	K007	= KLE	+
EDITED	JHE	MOBICAT MC 120 Z US					KLEEMANN MATERIAL NO	M20000111_01	CAE-SYSTEM: EPLAN 5.70
CONTR.	D. MALLKOWSKY	ORIGIN	REP.F.	REP.T.					PG. 39
MODIFICAT.	DATE	NAME	NORM	DIN					

# TERMINAL STRIP/PLUG

## +M-6X1

FUNCTION TEXT	CABLE DESIGNATION/TYPE	1	2	3	4	5	6	7	8	9				CABLE DESIGNATION/TYPE	PAGE/ PATH						
											DESIGNATION OF EXTERNAL DESTINATION	CONNECTION	NO.			BRIDGE		DESIGNATION OF INTERNAL DESTINATION	CONNECTION		
																INTERNAL WIRING	PLC DESIG- NATION			-12W1	OELFLEX Tray II
CONVEYOR BELT 6												-12W2 OELFLEX Tray II	4G								
=																					
=																					
=																					



# Cable overview

TPS\_PST2 15.04.2003

Cable name	Source	Target	Cable type	Total Cores	used Cores	Cross section mm <sup>2</sup>	Length m	Remark	Graphics Page
-03W1			OELFLEX Tray II	5G	4	-	-		/10
	-0X06	=100+M-E1		5G	2	-			/10
	-0X07	=100+M-E2		5G	2	-			/10
-03W2	-0X0	=100+M-B1	OELFLEX Tray II	3G	3G	-	-		/11
-06W1	-X0	=100+M-0S01	OELFLEX Tray II	5G	4	-	-		/12
-06W2	-X0	+M-XS2	OELFLEX Tray II	5G	4	-	-		/13
-06W3	-X0	=100+M-0S03	OELFLEX Tray II	5G	4	-	-		/14
-06W4	-X0	=100+M-0S04	OELFLEX Tray II	5G	4	-	-		/15
-06W5	-X0	+M-XS5	OELFLEX Tray II	5G	4	-	-		/16
-06W6	-X0	=100+M-0S06	OELFLEX Tray II	5G	4	-	-		/17
-06W7	-X0	=100+M-0S07	OELFLEX Tray II	5G	4	-	-		/18
-06W8	-4X2	=100+M-0S08	OELFLEX Tray II	5G	4	-	-		/19
-07W1	-XK	=100+M-Y9	OELFLEX Tray II	3G	2	-	-		/22
-07W2	-XK	=100+M-1H2	OELFLEX Tray II	3G	2	-	-		/23
-07W3	-X6	=100+M-00H2	OELFLEX Tray II	3G	2	-	-		/24
-07W4	-X6	=100+M-00H3	OELFLEX Tray II	3G	2	-	-		/25
-08W8	-X5	=100+M-1R1	OELFLEX Tray II	3G	2	-	-		/26
-10W1	-X1	=100+M-2M1	OELFLEX Tray II	4G	4G	-	-		/27
-10W2	-X1	=100+M-2Y1	OELFLEX Tray II	5G	5G	-	-		/28
-10W3	=100-3X2	=100+M-3M1	OELFLEX Tray II	4G	4G	-	-		/29
-11W1	-4X1	=100+M-4M1	OELFLEX Tray II	4G	4G	-	-		/30
-11W2	-4X1	=100+M-4M1	OELFLEX Tray II	3G	2	-	-		/31
-11W3	-X1	=100+M-5M1	OELFLEX Tray II	4G	4G	-	-		/32
-11W4	-X5	=100+M-5M1	OELFLEX Tray II	3G	2	-	-		/33
-11W5	-X1	=100+M-5M2	OELFLEX Tray II	4G	4G	-	-		/34
-11W6	-X5	=100+M-5M2	OELFLEX Tray II	3G	2	-	-		/35
-12W1	-X1	+M-6X1	OELFLEX Tray II	4G	4G	-	-		/36
-12W2	+M-6X1	=100+M-6M1	OELFLEX Tray II	4G	4G	-	-		/37
-12W3	-X1	=100+M-6X2	OELFLEX Tray II	4G	4G	-	-		/38
-12W4	-X1	=100+M-7M1	OELFLEX Tray II	4G	4G	-	-		/39
-12W5	-X5	=100+M-7M1	OELFLEX Tray II	3G	2	-	-		/40
-13W1	-X1	=100+M-9M1	OELFLEX Tray II	4G	4G	-	-		/41
-13W2	-X1	=100+M-WP	OELFLEX Tray II	3G	3G	-	-		/42
-13W3	-X1	=100+M-13M1	OELFLEX Tray II	4G	4G	-	-		/43
-14W1	-X8	=100+M-8M1	OELFLEX FD855CP	4G+Schirm	4G	2.5	-		/44

=KLE/39

2

DATE	18.Apr.2012	KLEEMANN GMBH		 	KABELUEBERSICHT/ CABLE SURVEY	KLEEMANN SERIES	K007	= KAB	+
EDITED	JHE	MOBICAT MC 120 Z US				KLEEMANN MATERIAL NO	M20000111_01	CAE-SYSTEM: EPLAN 5.70	PG.
CONTR.	D. MALLKOWSKY	ORIGIN	REP.F.	REP.T.				PG.	56

# Cable overview

TPS\_PST2 15.04.2003

Cable id	Source from	Target to	Cable type	Total Cores	used Cores	Cross section mm <sup>2</sup>	Length m	Remark	Graphics Page
-14W2	-X5	=100+M-8M1	OELFLEX Tray II	3G	2	1.5	-		/45
-14W3	-X8	=100+M-8M2	OELFLEX FD855CP	4G+Schirm	4G	2.5	-		/46
-14W4	-X5	=100+M-8M2	OELFLEX Tray II	3G	2	1.5	-		/47
-36W1	-XLS	=100+M-LR	UNITRONIC	3+Schirm	2	0.5	-		/48
-36W2	-XLS	=100+M-LT	UNITRONIC	3+Schirm	2	0.5	-		/49
-37W1	-XG	+M-XG	OELFLEX Tray II	4G	2	-	-		/50
-37W2	-XG	+M-XG	OELFLEX Tray II	18G	12	-	-		/51
-41W1			OELFLEX Tray II	18G	14	-	-		/52
	-XF	=100+M-20A2		18G	10	-	-		/52
	-X22	=100+M-20A2		18G	4	-	-		/52
-41W2	-X22	=100+M-Y5B	OELFLEX 491P	5G	4	-	-		/53
-41W3	-X22	=100+M-Y4B	OELFLEX 491P	5G	4	-	-		/54
-41W4	-X22	+M-XF1	OELFLEX Tray II	7G	6	-	-		/55
-41W5	-XB	=100+M-Y3	OELFLEX Tray II	3G	2	-	-		/56
-06W12	+M-XS2	=100+M-0S02	OELFLEX Tray II	5G	4	-	-		/20
-06W15	+M-XS5	=100+M-0S05	OELFLEX Tray II	5G	4	-	-		/21

**INTERCONNECTION DIAGRAM**

TPS\_N\_20.SKN / 2005-07-25

CABLE NAME **-03W1** CABLE TYPE **OELFLEX Tray II**

REMARK NO. OF CORES **5G** CROSS SECTION **-** CABLE LENGTH **-**

FUNCTION TEXT	PAGE/PATH	DESTINATION DESIGNATION FROM	CONNECTION	CORE	DESTINATION DESIGNATION TO	CONNECTION	PAGE/PATH	FUNCTION TEXT
ILLUMINATION 1	=100/3.1	-0X06	1	1	=100+M-E1	X1	=100/3.1	ILLUMINATION 1
ILLUMINATION 1	=100/3.1	-0X06	2	2	=100+M-E1	X2	=100/3.1	ILLUMINATION 1
ILLUMINATION 2	=100/3.3	-0X07	1	3	=100+M-E2	X1	=100/3.3	ILLUMINATION 2
ILLUMINATION 2	=100/3.3	-0X07	2	4	=100+M-E2	X2	=100/3.3	ILLUMINATION 2
				PE				

2	DATE 18.Apr.2012	KLEEMANN GMBH	 	-03W1	KLEEMANN SERIES K007	= KAB	+	
	EDITED JHE	MOBICAT MC 120 Z US						
	CONTR. D. MALLKOWSKY				KLEEMANN MATERIAL NO M20000111_01	CAE-SYSTEM: EPLAN 5.70	PG. 10	
MODIFICAT.	DATE	NAME	NORM	DIN	ORIGIN	REP.F.	REP.T.	PG. 56



# INTERCONNECTION DIAGRAM

TPS\_N\_20.SKN / 2005-07-25

CABLE NAME **-06W1** CABLE TYPE **OELFLEX Tray II**

REMARK NO. OF CORES **5G** CROSS SECTION **-** CABLE LENGTH **-**

FUNCTION TEXT	PAGE/PATH	DESTINATION DESIGNATION FROM	CONNECTION	CORE	DESTINATION DESIGNATION TO	CONNECTION	PAGE/PATH	FUNCTION TEXT
E-STOP PUSH-BUTTON	=100/6.0	-X0	1	1	=100+M-0S01	21	=100/6.0	E-STOP PUSH-BUTTON
E-STOP PUSH-BUTTON	=100/6.0	-X0	3	2	=100+M-0S01	22	=100/6.0	E-STOP PUSH-BUTTON
E-STOP PUSH-BUTTON	=100/6.1	-X0	2	3	=100+M-0S01	11	=100/6.1	E-STOP PUSH-BUTTON
E-STOP PUSH-BUTTON	=100/6.1	-X0	4	4	=100+M-0S01	12	=100/6.1	E-STOP PUSH-BUTTON
				PE				

DATE	18.Apr.2012	KLEEMANN GMBH		 	-06W1	KLEEMANN SERIES	K007	= KAB	+	
EDITED	JHE	MOBICAT MC 120 Z US			KLEEMANN MATERIAL NO	M20000111_01	CAE-SYSTEM:	EPLAN 5.70	PG.	12
CONTR.	D. MALLKOWSKY	ORIGIN	REP.F.		REP.T.				PG.	56
MODIFICAT.	DATE	NAME	NORM	DIN	ORIGIN	REP.F.	REP.T.			

# INTERCONNECTION DIAGRAM

CABLE NAME	-06W2	CABLE TYPE	OELFLEX Tray II
------------	-------	------------	-----------------

REMARK		NO. OF CORES	5G	CROSS SECTION	-	CABLE LENGTH	-
--------	--	--------------	----	---------------	---	--------------	---

FUNCTION TEXT	PAGE/PATH	DESTINATION DESIGNATION FROM	CONNECTION	CORE	DESTINATION DESIGNATION TO	CONNECTION	PAGE/PATH	FUNCTION TEXT
E-STOP PUSH-BUTTON	=100/6.0	-X0	3	1	+M-XS2	1	=100/6.1	E-STOP PUSH-BUTTON
E-STOP PUSH-BUTTON	=100/6.0	-X0	5	2	+M-XS2	2	=100/6.1	E-STOP PUSH-BUTTON
E-STOP PUSH-BUTTON	=100/6.1	-X0	4	3	+M-XS2	3	=100/6.1	E-STOP PUSH-BUTTON
E-STOP PUSH-BUTTON	=100/6.1	-X0	6	4	+M-XS2	4	=100/6.1	E-STOP PUSH-BUTTON
				PE				

DATE	18.Apr.2012	KLEEMANN GMBH		-06W2	KLEEMANN SERIES	K007	= KAB	+	
EDITED	JHE				KLEEMANN MATERIAL NO	M20000111_01	CAE-SYSTEM: EPLAN 5.70	PG.	13
CONTR.	D. MALLKOWSKY							MOBICAT MC 120 Z US	PG.
MODIFICAT.	DATE	NAME	NORM	DIN	ORIGIN	REP.F.	REP.T.		

# INTERCONNECTION DIAGRAM

CABLE NAME **-06W3** CABLE TYPE **OELFLEX Tray II**

REMARK NO. OF CORES **5G** CROSS SECTION **-** CABLE LENGTH **-**

FUNCTION TEXT	PAGE/PATH	DESTINATION DESIGNATION FROM	CONNECTION	CORE	DESTINATION DESIGNATION TO	CONNECTION	PAGE/PATH	FUNCTION TEXT
E-STOP PUSH-BUTTON	=100/6.0	-X0	5	1	=100+M-0S03	21	=100/6.0	E-STOP PUSH-BUTTON
E-STOP PUSH-BUTTON	=100/6.0	-X0	7	2	=100+M-0S03	22	=100/6.0	E-STOP PUSH-BUTTON
E-STOP PUSH-BUTTON	=100/6.1	-X0	6	3	=100+M-0S03	11	=100/6.1	E-STOP PUSH-BUTTON
E-STOP PUSH-BUTTON	=100/6.1	-X0	8	4	=100+M-0S03	12	=100/6.1	E-STOP PUSH-BUTTON
				PE				

DATE	18.Apr.2012	KLEEMANN GMBH		-06W3	KLEEMANN SERIES	K007	= KAB	+	
EDITED	JHE	MOBICAT MC 120 Z US			KLEEMANN MATERIAL NO	M20000111_01	CAE-SYSTEM:	EPLAN 5.70	PG.
CONTR.	D. MALLKOWSKY		REP.F.	REP.T.				PG.	56
MODIFICAT.	DATE	NAME	NORM	DIN	ORIGIN				







INTERCONNECTION DIAGRAM

CABLE NAME <b>-06W6</b>				CABLE TYPE <b>OELFLEX Tray II</b>				
-------------------------	--	--	--	-----------------------------------	--	--	--	--

REMARK				NO. OF CORES <b>5G</b>		CROSS SECTION <b>-</b>		CABLE LENGTH <b>-</b>	
--------	--	--	--	------------------------	--	------------------------	--	-----------------------	--

FUNCTION TEXT	PAGE/PATH	DESTINATION DESIGNATION FROM	CONNECTION	CORE	DESTINATION DESIGNATION TO	CONNECTION	PAGE/PATH	FUNCTION TEXT
E-STOP PUSH-BUTTON	=100/6.2	-X0	11	1	=100+M-0S06	21	=100/6.3	E-STOP PUSH-BUTTON
E-STOP PUSH-BUTTON	=100/6.3	-X0	13	2	=100+M-0S06	22	=100/6.3	E-STOP PUSH-BUTTON
E-STOP PUSH-BUTTON	=100/6.2	-X0	12	3	=100+M-0S06	11	=100/6.4	E-STOP PUSH-BUTTON
E-STOP PUSH-BUTTON	=100/6.4	-X0	14	4	=100+M-0S06	12	=100/6.4	E-STOP PUSH-BUTTON
				PE				

DATE	18.Apr.2012	KLEEMANN GMBH			 	-06W6	KLEEMANN SERIES	K007	= KAB	+	
EDITED	JHE	MOBICAT MC 120 Z US				KLEEMANN MATERIAL NO	M20000111_01	CAE-SYSTEM:	EPLAN 5.70	PG.	17
CONTR.	D. MALLKOWSKY	ORIGIN	REP.F.	REP.T.		PG.	56				
MODIFICAT.	DATE	NAME	NORM	DIN	ORIGIN	REP.F.	REP.T.				

**INTERCONNECTION DIAGRAM**

CABLE NAME	-06W7	CABLE TYPE	OELFLEX Tray II
------------	-------	------------	-----------------

REMARK		NO. OF CORES	5G	CROSS SECTION	-	CABLE LENGTH	-
--------	--	--------------	----	---------------	---	--------------	---

FUNCTION TEXT	PAGE/PATH	DESTINATION DESIGNATION FROM	CONNECTION	CORE	DESTINATION DESIGNATION TO	CONNECTION	PAGE/PATH	FUNCTION TEXT
E-STOP PUSH-BUTTON	=100/6.3	-X0	13	1	=100+M-0S07	21	=100/6.4	E-STOP PUSH-BUTTON
E-STOP PUSH-BUTTON	=100/6.4	-X0	15	2	=100+M-0S07	22	=100/6.4	E-STOP PUSH-BUTTON
E-STOP PUSH-BUTTON	=100/6.4	-X0	14	3	=100+M-0S07	11	=100/6.4	E-STOP PUSH-BUTTON
E-STOP PUSH-BUTTON	=100/6.4	-X0	16	4	=100+M-0S07	12	=100/6.4	E-STOP PUSH-BUTTON
				PE				

DATE	18.Apr.2012	KLEEMANN GMBH	 	-06W7	KLEEMANN SERIES	K007	= KAB	+	
EDITED	JHE	MOBICAT MC 120 Z US			KLEEMANN MATERIAL NO	M20000111_01	CAE-SYSTEM:	EPLAN 5.70	PG. 18
CONTR.	D. MALLKOWSKY								PG. 56
MODIFICAT.	DATE	NAME	NORM	DIN	ORIGIN	REP.F.	REP.T.		

### INTERCONNECTION DIAGRAM

TPS\_N\_20.SKN / 2005-07-25

CABLE NAME <b>-06W8</b>	CABLE TYPE <b>OELFLEX Tray II</b>
-------------------------	-----------------------------------

REMARK	NO. OF CORES <b>5G</b>	CROSS SECTION <b>-</b>	CABLE LENGTH <b>-</b>
--------	------------------------	------------------------	-----------------------

FUNCTION TEXT	PAGE/PATH	DESTINATION DESIGNATION FROM	CONNECTION	CORE	DESTINATION DESIGNATION TO	CONNECTION	PAGE/PATH	FUNCTION TEXT
EMERGENCY STOP SWITCHGEAR	=100/6.5	-4X2	1	1	=100+M-0S08	22	=100/6.5	EMERGENCY STOP SWITCHGEAR
EMERGENCY STOP SWITCHGEAR	=100/6.5	-4X2	2	2	=100+M-0S08	21	=100/6.5	EMERGENCY STOP SWITCHGEAR
EMERGENCY STOP SWITCHGEAR	=100/6.6	-4X2	3	3	=100+M-0S08	12	=100/6.6	EMERGENCY STOP SWITCHGEAR
EMERGENCY STOP SWITCHGEAR	=100/6.6	-4X2	4	4	=100+M-0S08	11	=100/6.6	EMERGENCY STOP SWITCHGEAR
				PE				

**INTERCONNECTION DIAGRAM**

TPS\_N\_20.SKN / 2005-07-25

CABLE NAME **-06W12** CABLE TYPE **OELFLEX Tray II**

REMARK NO. OF CORES **5G** CROSS SECTION **-** CABLE LENGTH **-**

FUNCTION TEXT	PAGE/PATH	DESTINATION DESIGNATION FROM	CONNECTION	CORE	DESTINATION DESIGNATION TO	CONNECTION	PAGE/PATH	FUNCTION TEXT
E-STOP PUSH-BUTTON	=100/6.1	+M-XS2	1	1	=100+M-0S02	21	=100/6.1	E-STOP PUSH-BUTTON
E-STOP PUSH-BUTTON	=100/6.1	+M-XS2	2	2	=100+M-0S02	22	=100/6.1	E-STOP PUSH-BUTTON
E-STOP PUSH-BUTTON	=100/6.1	+M-XS2	3	3	=100+M-0S02	11	=100/6.1	E-STOP PUSH-BUTTON
E-STOP PUSH-BUTTON	=100/6.1	+M-XS2	4	4	=100+M-0S02	12	=100/6.1	E-STOP PUSH-BUTTON
				PE				

DATE	18.Apr.2012	KLEEMANN GMBH MOBICAT MC 120 Z US			-06W12	KLEEMANN SERIES	K007	= KAB	+		
EDITED	JHE					KLEEMANN MATERIAL NO	M20000111_01			CAE-SYSTEM:	EPLAN 5.70
CONTR.	D. MALLKOWSKY							REP.F.	REP.T.	PG.	56

## INTERCONNECTION DIAGRAM

<b>CABLE NAME</b> -06W15	<b>CABLE TYPE</b> OELFLEX Tray II
<b>REMARK</b>	<b>NO. OF CORES</b> 5G <b>CROSS SECTION</b> - <b>CABLE LENGTH</b> -

FUNCTION TEXT	PAGE/PATH	DESTINATION DESIGNATION FROM	CONNECTION	CORE	DESTINATION DESIGNATION TO	CONNECTION	PAGE/PATH	FUNCTION TEXT
E-STOP PUSH-BUTTON	=100/6.2	+M-XS5	2	1	=100+M-0S05	21	=100/6.2	E-STOP PUSH-BUTTON
E-STOP PUSH-BUTTON	=100/6.2	+M-XS5	1	2	=100+M-0S05	22	=100/6.2	E-STOP PUSH-BUTTON
E-STOP PUSH-BUTTON	=100/6.2	+M-XS5	4	3	=100+M-0S05	11	=100/6.2	E-STOP PUSH-BUTTON
E-STOP PUSH-BUTTON	=100/6.2	+M-XS5	3	4	=100+M-0S05	12	=100/6.2	E-STOP PUSH-BUTTON
				PE				

20	<table style="width:100%;"> <tr><td>DATE</td><td>18.Apr.2012</td><td rowspan="3" style="text-align:center;">KLEEMANN GMBH</td></tr> <tr><td>EDITED</td><td>JHE</td></tr> <tr><td>CONTR.</td><td>D. MALLKOWSKY</td></tr> </table>	DATE	18.Apr.2012	KLEEMANN GMBH	EDITED	JHE	CONTR.	D. MALLKOWSKY		-06W15	KLEEMANN SERIES K007	= KAB	+
DATE	18.Apr.2012	KLEEMANN GMBH											
EDITED	JHE												
CONTR.	D. MALLKOWSKY												
MODIFICAT.	DATE	NAME	NORM	DIN	ORIGIN	REP.F.	REP.T.	KLEEMANN MATERIAL NO M20000111_01	CAE-SYSTEM: EPLAN 5.70	PG. 21			
										PG. 56			



### INTERCONNECTION DIAGRAM

TPS\_N\_20.SKN / 2005-07-25

CABLE NAME <b>-07W2</b>	CABLE TYPE <b>OELFLEX Tray II</b>
-------------------------	-----------------------------------

REMARK	NO. OF CORES <b>3G</b>	CROSS SECTION <b>-</b>	CABLE LENGTH <b>-</b>
--------	------------------------	------------------------	-----------------------

FUNCTION TEXT	PAGE/PATH	DESTINATION DESIGNATION FROM	CONNECTION	CORE	DESTINATION DESIGNATION TO	CONNECTION	PAGE/PATH	FUNCTION TEXT
RUN WARNING	=100/7.6	-XK	1	1	=100+M-1H2	A1	=100/7.6	RUN WARNING
RUN WARNING	=100/7.6	-XK	2	2	=100+M-1H2	A2	=100/7.6	RUN WARNING
				PE				

DATE	18.Apr.2012	KLEEMANN GMBH			-07W2	KLEEMANN SERIES	K007	= KAB	+		
CONTR.	D. MALLKOWSKY	MOBICAT MC 120 Z US				KLEEMANN MATERIAL NO	M20000111_01	CAE-SYSTEM:	EPLAN 5.70	PG.	23
MODIFICAT.	DATE	NAME				NORM	DIN	ORIGIN	REP.F.	REP.T.	PG.



# INTERCONNECTION DIAGRAM

CABLE NAME <b>-07W3</b>					CABLE TYPE <b>OELFLEX Tray II</b>			
REMARK					NO. OF CORES <b>3G</b>		CROSS SECTION <b>-</b>	CABLE LENGTH <b>-</b>
FUNCTION TEXT	PAGE/PATH	DESTINATION DESIGNATION FROM	CONNECTION	CORE	DESTINATION DESIGNATION TO	CONNECTION	PAGE/PATH	FUNCTION TEXT
HOOTER	=100/7.7	-X6	1	1	=100+M-00H2	A1	=100/7.7	HOOTER
HOOTER	=100/7.7	-X6	2	2	=100+M-00H2	A2	=100/7.7	HOOTER
				PE				

DATE	18.Apr.2012	KLEEMANN GMBH		 	-07W3	KLEEMANN SERIES	K007	= KAB	+
EDITED	JHE	MOBICAT MC 120 Z US			KLEEMANN MATERIAL NO	M20000111_01	CAE-SYSTEM:	EPLAN 5.70	PG.
CONTR.	D. MALLKOWSKY	ORIGIN	REP.F.	REP.T.				PG.	56

# INTERCONNECTION DIAGRAM

TPS\_N\_20.SKN / 2005-07-25

CABLE NAME <b>-07W4</b>	CABLE TYPE <b>OELFLEX Tray II</b>
-------------------------	-----------------------------------

REMARK	NO. OF CORES <b>3G</b>	CROSS SECTION <b>-</b>	CABLE LENGTH <b>-</b>
--------	------------------------	------------------------	-----------------------

FUNCTION TEXT	PAGE/PATH	DESTINATION DESIGNATION FROM	CONNECTION	CORE	DESTINATION DESIGNATION TO	CONNECTION	PAGE/PATH	FUNCTION TEXT
FLASHING LIGHT	=100/7.8	-X6	3	1	=100+M-00H3	X1	=100/7.8	FLASHING LIGHT
FLASHING LIGHT	=100/7.8	-X6	4	2	=100+M-00H3	X2	=100/7.8	FLASHING LIGHT
				PE				

24 26

		DATE	18.Apr.2012	KLEEMANN GMBH		-07W4	KLEEMANN SERIES	K007	= KAB	+
		EDITED	JHE	MOBICAT MC 120 Z US			KLEEMANN MATERIAL NO	M20000111_01	CAE-SYSTEM:	PG. 25
MODIFICAT.	DATE	NAME	NORM	DIN	ORIGIN	REP.F.	REP.T.		EPLAN 5.70	PG. 56

<b>CABLE NAME</b> <b>-08W8</b>	<b>CABLE TYPE</b> <b>OELFLEX Tray II</b>
<b>REMARK</b>	<b>NO. OF CORES</b> <b>3G</b> <b>CROSS SECTION</b> <b>-</b> <b>CABLE LENGTH</b> <b>-</b>

FUNCTION TEXT	PAGE/PATH	DESTINATION DESIGNATION FROM	CONNECTION	CORE	DESTINATION DESIGNATION TO	CONNECTION	PAGE/PATH	FUNCTION TEXT
MOTOR PROTECTION RELAY	=100/8.6	-X5	1	1	=100+M-1R1		=100/8.6	MOTOR PROTECTION RELAY
MOTOR PROTECTION RELAY	=100/8.6	-X5	2	2	=100+M-1R1		=100/8.6	MOTOR PROTECTION RELAY
				PE				

INTERCONNECTION DIAGRAM

TPS\_N\_20.SKN / 2005-07-25

CABLE NAME **-10W1** CABLE TYPE **OELFLEX Tray II**

REMARK NO. OF CORES **4G** CROSS SECTION **-** CABLE LENGTH **-**

FUNCTION TEXT	PAGE/PATH	DESTINATION DESIGNATION FROM	CONNECTION	CORE	DESTINATION DESIGNATION TO	CONNECTION	PAGE/PATH	FUNCTION TEXT
MAGNETIC BELT 2	=100/10.1	-X1	1	1	=100+M-2M1	U	=100/10.1	MAGNETIC BELT 2
MAGNETIC BELT 2	=100/10.1	-X1	2	2	=100+M-2M1	V	=100/10.1	MAGNETIC BELT 2
MAGNETIC BELT 2	=100/10.1	-X1	3	3	=100+M-2M1	W	=100/10.1	MAGNETIC BELT 2
MAGNETIC BELT 2	=100/10.2	-X1	PE	PE	=100+M-2M1	PE	=100/10.1	MAGNETIC BELT 2

		DATE	18.Apr.2012	
		EDITED	JHE	
		CONTR.	D. MALLKOWSKY	
MODIFICAT.	DATE	NAME	NORM	DIN

KLEEMANN GMBH  
MOBICAT MC 120 Z US  
ORIGIN REP.F.



-10W1

KLEEMANN SERIES	K007	= KAB	+
KLEEMANN MATERIAL NO	M20000111_01	CAE-SYSTEM: EPLAN 5.70	PG. 27 PG. 56

### INTERCONNECTION DIAGRAM

TPS\_N\_20.SKN / 2005-07-25

CABLE NAME	<b>-10W2</b>	CABLE TYPE	<b>OELFLEX Tray II</b>				
REMARK		NO. OF CORES	<b>5G</b>	CROSS SECTION	<b>-</b>	CABLE LENGTH	<b>-</b>

FUNCTION TEXT	PAGE/PATH	DESTINATION DESIGNATION FROM	CONNECTION	CORE	DESTINATION DESIGNATION TO	CONNECTION	PAGE/PATH	FUNCTION TEXT
MAGNET	=100/10.4	-X1	4	1	=100+M-2Y1	L1	=100/10.4	MAGNETIC BELT 2
MAGNET	=100/10.4	-X1	5	2	=100+M-2Y1	L2	=100/10.4	MAGNETIC BELT 2
MAGNET	=100/10.4	-X1	6	3	=100+M-2Y1	L3	=100/10.4	MAGNETIC BELT 2
MAGNET	=100/10.4	-X1	7	4	=100+M-2Y1	N	=100/10.4	MAGNETIC BELT 2
MAGNET	=100/10.5	-X1	PE	PE	=100+M-2Y1	PE	=100/10.4	MAGNETIC BELT 2

DATE	18.Apr.2012	KLEEMANN GMBH	 	-10W2	KLEEMANN SERIES	<b>K007</b>	<b>= KAB</b>	+
EDITED	JHE	MOBICAT MC 120 Z US		KLEEMANN MATERIAL NO	<b>M20000111_01</b>	CAE-SYSTEM: EPLAN 5.70	PG. 28	
CONTR.	D. MALLKOWSKY	ORIGIN	REP.F.	REP.T.	PG. 56			
MODIFICAT.	DATE	NAME	NORM	DIN				



**INTERCONNECTION DIAGRAM**

TPS\_N\_20.SKN / 2005-07-25

CABLE NAME <b>-11W1</b>				CABLE TYPE <b>OELFLEX Tray II</b>					
REMARK				NO. OF CORES <b>4G</b>		CROSS SECTION <b>-</b>		CABLE LENGTH <b>-</b>	
FUNCTION TEXT	PAGE/PATH	DESTINATION DESIGNATION FROM	CONNECTION	CORE	DESTINATION DESIGNATION TO	CONNECTION	PAGE/PATH	FUNCTION TEXT	
CONVEYOR BELT 4	=100/11.1	-4X1	1	1	=100+M-4M1	U	=100/11.1	CONVEYOR BELT 4	
CONVEYOR BELT 4	=100/11.1	-4X1	2	2	=100+M-4M1	V	=100/11.2	CONVEYOR BELT 4	
CONVEYOR BELT 4	=100/11.1	-4X1	3	3	=100+M-4M1	W	=100/11.2	CONVEYOR BELT 4	
CONVEYOR BELT 4	=100/11.2	-4X1	PE	PE	=100+M-4M1	PE	=100/11.2	CONVEYOR BELT 4	

DATE	18.Apr.2012	KLEEMANN GMBH					-11W1	KLEEMANN SERIES	K007	= KAB	+
EDITED	JHE	MOBICAT MC 120 Z US						KLEEMANN MATERIAL NO	M20000111_01	CAE-SYSTEM:	EPLAN 5.70
CONTR.	D. MALLKOWSKY	ORIGIN	REP.F.	REP.T.						PG.	56





0 1 2 3 4 5 6 7 8 9

# INTERCONNECTION DIAGRAM

TPS\_N\_20.SKN / 2005-07-25

CABLE NAME <b>-11W3</b>					CABLE TYPE <b>OELFLEX Tray II</b>					
REMARK					NO. OF CORES <b>4G</b>		CROSS SECTION <b>-</b>		CABLE LENGTH <b>-</b>	
FUNCTION TEXT	PAGE/PATH	DESTINATION DESIGNATION FROM	CONNECTION	CORE	DESTINATION DESIGNATION TO	CONNECTION	PAGE/PATH	FUNCTION TEXT		
VIBRATING CHUTE/CRUSHER 5	=100/11.4	-X1	8	1	=100+M-5M1	U	=100/11.4	VIBRATING CHUTE/CRUSHER 5		
VIBRATING CHUTE/CRUSHER 5	=100/11.4	-X1	9	2	=100+M-5M1	V	=100/11.4	VIBRATING CHUTE/CRUSHER 5		
VIBRATING CHUTE/CRUSHER 5	=100/11.4	-X1	10	3	=100+M-5M1	W	=100/11.4	VIBRATING CHUTE/CRUSHER 5		
VIBRATING CHUTE/CRUSHER 5	=100/11.4	-X1	PE	PE	=100+M-5M1	PE	=100/11.4	VIBRATING CHUTE/CRUSHER 5		

**INTERCONNECTION DIAGRAM**

TPS\_N\_20.SKN / 2005-07-25

CABLE NAME **-11W4** CABLE TYPE **OELFLEX Tray II**

REMARK NO. OF CORES **3G** CROSS SECTION **-** CABLE LENGTH **-**

FUNCTION TEXT	PAGE/PATH	DESTINATION DESIGNATION FROM	CONNECTION	CORE	DESTINATION DESIGNATION TO	CONNECTION	PAGE/PATH	FUNCTION TEXT
VIBRATING CHUTE/CRUSHER 5	=100/11.5	-X5	3	1	=100+M-5M1		=100/11.4	VIBRATING CHUTE/CRUSHER 5
VIBRATING CHUTE/CRUSHER 5	=100/11.5	-X5	4	2	=100+M-5M1		=100/11.4	VIBRATING CHUTE/CRUSHER 5
				PE				

DATE	18.Apr.2012	KLEEMANN GMBH MOBICAT MC 120 Z US	 	-11W4	KLEEMANN SERIES	K007	= KAB	+		
EDITED	JHE				KLEEMANN MATERIAL NO	M20000111_01	CAE-SYSTEM:	EPLAN 5.70	PG.	33
CONTR.	D. MALLKOWSKY				REP.F.		REP.T.		PG.	56
MODIFICAT.	DATE	NAME	NORM	DIN	ORIGIN					

INTERCONNECTION DIAGRAM

TPS\_N\_20.SKN / 2005-07-25

CABLE NAME **-11W5** CABLE TYPE **OELFLEX Tray II**

REMARK NO. OF CORES **4G** CROSS SECTION **-** CABLE LENGTH **-**

FUNCTION TEXT	PAGE/PATH	DESTINATION DESIGNATION FROM	CONNECTION	CORE	DESTINATION DESIGNATION TO	CONNECTION	PAGE/PATH	FUNCTION TEXT
VIBRATING CHUTE/CRUSHER 5	=100/11.7	-X1	11	1	=100+M-5M2	U	=100/11.7	VIBRATING CHUTE/CRUSHER 5
VIBRATING CHUTE/CRUSHER 5	=100/11.7	-X1	12	2	=100+M-5M2	V	=100/11.7	VIBRATING CHUTE/CRUSHER 5
VIBRATING CHUTE/CRUSHER 5	=100/11.7	-X1	13	3	=100+M-5M2	W	=100/11.7	VIBRATING CHUTE/CRUSHER 5
VIBRATING CHUTE/CRUSHER 5	=100/11.7	-X1	PE	PE	=100+M-5M2	PE	=100/11.7	VIBRATING CHUTE/CRUSHER 5

DATE	18.Apr.2012	KLEEMANN GMBH					-11W5	KLEEMANN SERIES	K007	= KAB	+
EDITED	JHE	MOBICAT MC 120 Z US						KLEEMANN MATERIAL NO	M20000111_01	CAE-SYSTEM: EPLAN 5.70	PG. 34
CONTR.	D. MALLKOWSKY	ORIGIN	REP.F.	REP.T.					PG. 56		
MODIFICAT.	DATE	NAME	NORM	DIN							



INTERCONNECTION DIAGRAM

TPS\_N\_20.SKN / 2005-07-25

CABLE NAME **-12W1** CABLE TYPE **OELFLEX Tray II**

REMARK NO. OF CORES **4G** CROSS SECTION **-** CABLE LENGTH **-**

FUNCTION TEXT	PAGE/PATH	DESTINATION DESIGNATION FROM	CONNECTION	CORE	DESTINATION DESIGNATION TO	CONNECTION	PAGE/PATH	FUNCTION TEXT
CONVEYOR BELT 6	=100/12.1	-X1	14	1	+M-6X1	1	=100/12.1	CONVEYOR BELT 6
CONVEYOR BELT 6	=100/12.1	-X1	15	2	+M-6X1	2	=100/12.1	CONVEYOR BELT 6
CONVEYOR BELT 6	=100/12.1	-X1	16	3	+M-6X1	3	=100/12.1	CONVEYOR BELT 6
CONVEYOR BELT 6	=100/12.2	-X1	PE	PE	+M-6X1	PE	=100/12.2	CONVEYOR BELT 6

DATE		18.Apr.2012		KLEEMANN GMBH			-12W1	KLEEMANN SERIES <b>K007</b>		= KAB	+	
EDITED		JHE		MOBICAT MC 120 Z US				KLEEMANN MATERIAL NO <b>M20000111_01</b>		CAE-SYSTEM: EPLAN 5.70		PG. <b>36</b>
CONTR.		D. MALLKOWSKY						ORIGIN	REP.F.	REP.T.		

**INTERCONNECTION DIAGRAM**

CABLE NAME **-12W2** CABLE TYPE **OELFLEX Tray II**

REMARK NO. OF CORES **4G** CROSS SECTION **-** CABLE LENGTH **-**

FUNCTION TEXT	PAGE/PATH	DESTINATION DESIGNATION FROM	CONNECTION	CORE	DESTINATION DESIGNATION TO	CONNECTION	PAGE/PATH	FUNCTION TEXT
CONVEYOR BELT 6	=100/12.1	+M-6X1	1	1	=100+M-6M1	U	=100/12.1	CONVEYOR BELT 6
CONVEYOR BELT 6	=100/12.1	+M-6X1	2	2	=100+M-6M1	V	=100/12.1	CONVEYOR BELT 6
CONVEYOR BELT 6	=100/12.1	+M-6X1	3	3	=100+M-6M1	W	=100/12.1	CONVEYOR BELT 6
CONVEYOR BELT 6	=100/12.2	+M-6X1	PE	PE	=100+M-6M1	PE	=100/12.1	CONVEYOR BELT 6

DATE	18.Apr.2012	KLEEMANN GMBH	 	-12W2	KLEEMANN SERIES	K007	= KAB	+	
EDITED	JHE	MOBICAT MC 120 Z US			KLEEMANN MATERIAL NO	M20000111_01	CAE-SYSTEM:	EPLAN 5.70	PG. 37
CONTR.	D. MALLKOWSKY								PG. 56
MODIFICAT.	DATE	NAME	NORM	DIN	ORIGIN	REP.F.	REP.T.		

# INTERCONNECTION DIAGRAM

CABLE NAME <b>-12W3</b>					CABLE TYPE <b>OELFLEX Tray II</b>					
REMARK					NO. OF CORES <b>4G</b>		CROSS SECTION <b>-</b>		CABLE LENGTH <b>-</b>	
FUNCTION TEXT	PAGE/PATH	DESTINATION DESIGNATION FROM	CONNECTION	CORE	DESTINATION DESIGNATION TO	CONNECTION	PAGE/PATH	FUNCTION TEXT		
CONVEYOR BELT 6	=100/12.1	-X1	14	1	=100+M-6X2	1	=100/12.2	CONVEYOR BELT 6		
CONVEYOR BELT 6	=100/12.1	-X1	15	2	=100+M-6X2	2	=100/12.2	CONVEYOR BELT 6		
CONVEYOR BELT 6	=100/12.1	-X1	16	3	=100+M-6X2	3	=100/12.2	CONVEYOR BELT 6		
CONVEYOR BELT 6	=100/12.2	-X1	PE	PE	=100+M-6X2	PE	=100/12.3	CONVEYOR BELT 6		

37

39

	DATE	18.Apr.2012	KLEEMANN GMBH				-12W3	KLEEMANN SERIES	K007	= KAB	+
	EDITED	JHE	MOBICAT MC 120 Z US					KLEEMANN MATERIAL NO	M20000111_01	CAE-SYSTEM:	PG. 38
MODIFICAT.	DATE	NAME	NORM	DIN	ORIGIN	REP.F.	REP.T.			EPLAN 5.70	PG. 56

**INTERCONNECTION DIAGRAM**

TPS\_N\_20.SKN / 2005-07-25

CABLE NAME <b>-12W4</b>	CABLE TYPE <b>OELFLEX Tray II</b>
-------------------------	-----------------------------------

REMARK	NO. OF CORES <b>4G</b>	CROSS SECTION <b>-</b>	CABLE LENGTH <b>-</b>
--------	------------------------	------------------------	-----------------------

FUNCTION TEXT	PAGE/PATH	DESTINATION DESIGNATION FROM	CONNECTION	CORE	DESTINATION DESIGNATION TO	CONNECTION	PAGE/PATH	FUNCTION TEXT
VIBRATING SCREEN 7	=100/12.4	-X1	17	1	=100+M-7M1	U1	=100/12.4	VIBRATING SCREEN 7
VIBRATING SCREEN 7	=100/12.4	-X1	18	2	=100+M-7M1	V1	=100/12.4	VIBRATING SCREEN 7
VIBRATING SCREEN 7	=100/12.4	-X1	19	3	=100+M-7M1	W1	=100/12.4	VIBRATING SCREEN 7
VIBRATING SCREEN 7	=100/12.4	-X1	PE	PE	=100+M-7M1	PE	=100/12.4	VIBRATING SCREEN 7

DATE	18.Apr.2012	KLEEMANN GMBH	 	-12W4	KLEEMANN SERIES	K007	= KAB	+	
EDITED	JHE	MOBICAT MC 120 Z US		KLEEMANN MATERIAL NO	M20000111_01	CAE-SYSTEM:	EPLAN 5.70	PG.	39
CONTR.	D. MALLKOWSKY			REP.T.				PG.	56
MODIFICAT.	DATE	NAME	NORM	DIN	ORIGIN	REP.F.	REP.T.		



**INTERCONNECTION DIAGRAM**

TPS\_N\_20.SKN / 2005-07-25

CABLE NAME **-12W5** CABLE TYPE **OELFLEX Tray II**

REMARK NO. OF CORES **3G** CROSS SECTION **-** CABLE LENGTH **-**

FUNCTION TEXT	PAGE/PATH	DESTINATION DESIGNATION FROM	CONNECTION	CORE	DESTINATION DESIGNATION TO	CONNECTION	PAGE/PATH	FUNCTION TEXT
VIBRATING SCREEN 7	=100/12.5	-X5	7	1	=100+M-7M1		=100/12.4	VIBRATING SCREEN 7
VIBRATING SCREEN 7	=100/12.5	-X5	8	2	=100+M-7M1		=100/12.4	VIBRATING SCREEN 7
				PE				

DATE	18.Apr.2012	KLEEMANN GMBH		 	-12W5	KLEEMANN SERIES	K007	= KAB	+	
EDITED	JHE	MOBICAT MC 120 Z US				KLEEMANN MATERIAL NO	M20000111_01	CAE-SYSTEM: EPLAN 5.70	PG.	40
CONTR.	D. MALLKOWSKY	ORIGIN	REP.F.			REP.T.			PG.	56
MODIFICAT.	DATE	NAME	NORM	DIN	ORIGIN	REP.F.	REP.T.			

# INTERCONNECTION DIAGRAM

TPS\_N\_20.SKN / 2005-07-25

CABLE NAME **-13W1** CABLE TYPE **OELFLEX Tray II**

REMARK NO. OF CORES **4G** CROSS SECTION **-** CABLE LENGTH **-**

FUNCTION TEXT	PAGE/PATH	DESTINATION DESIGNATION FROM	CONNECTION	CORE	DESTINATION DESIGNATION TO	CONNECTION	PAGE/PATH	FUNCTION TEXT
HYDRAULIC 9	=100/13.1	-X1	20	1	=100+M-9M1	U	=100/13.1	HYDRAULIC 9
HYDRAULIC 9	=100/13.1	-X1	21	2	=100+M-9M1	V	=100/13.1	HYDRAULIC 9
HYDRAULIC 9	=100/13.1	-X1	22	3	=100+M-9M1	W	=100/13.1	HYDRAULIC 9
HYDRAULIC 9	=100/13.2	-X1	PE	PE	=100+M-9M1	PE	=100/13.1	HYDRAULIC 9





# INTERCONNECTION DIAGRAM

TPS\_N\_20.SKN / 2005-07-25

CABLE NAME **-14W1** CABLE TYPE **OELFLEX FD855CP**

REMARK NO. OF CORES **4G+Schirm** CROSS SECTION **2.5** CABLE LENGTH **-**

FUNCTION TEXT	PAGE/PATH	DESTINATION DESIGNATION FROM	CONNECTION	CORE	DESTINATION DESIGNATION TO	CONNECTION	PAGE/PATH	FUNCTION TEXT
VIBRATING FEEDER 8 DRIVE LEFT	=100/14.2	-X8	1	1	=100+M-8M1	U1	=100/14.2	VIBRATING FEEDER 8 DRIVE LEFT
VIBRATING FEEDER 8 DRIVE LEFT	=100/14.2	-X8	2	2	=100+M-8M1	V1	=100/14.3	VIBRATING FEEDER 8 DRIVE LEFT
VIBRATING FEEDER 8 DRIVE LEFT	=100/14.3	-X8	3	3	=100+M-8M1	W1	=100/14.3	VIBRATING FEEDER 8 DRIVE LEFT
VIBRATING FEEDER 8 DRIVE LEFT	=100/14.3	-X8	PE	PE	=100+M-8M1	PE	=100/14.3	VIBRATING FEEDER 8 DRIVE LEFT
				SH				

DATE	18.Apr.2012	KLEEMANN GMBH	 	-14W1	KLEEMANN SERIES	K007	= KAB				
EDITED	JHE			MOBICAT MC 120 Z US							
CONTR.	D. MALLKOWSKY										
MODIFICAT.	DATE	NAME	NORM	DIN	ORIGIN	REP.F.	REP.T.	KLEEMANN MATERIAL NO	M20000111_01	CAE-SYSTEM: EPLAN 5.70	PG. 44 PG. 56

**INTERCONNECTION DIAGRAM**

TPS\_N\_20.SKN / 2005-07-25

CABLE NAME <b>-14W2</b>				CABLE TYPE <b>OELFLEX Tray II</b>				
REMARK				NO. OF CORES <b>3G</b>		CROSS SECTION <b>1.5</b>		CABLE LENGTH <b>-</b>

FUNCTION TEXT	PAGE/PATH	DESTINATION DESIGNATION FROM	CONNECTION	CORE	DESTINATION DESIGNATION TO	CONNECTION	PAGE/PATH	FUNCTION TEXT
VIBRATING FEEDER 8 DRIVE LEFT	=100/14.2	-X5	9	1	=100+M-8M1		=100/14.3	VIBRATING FEEDER 8 DRIVE LEFT
VIBRATING FEEDER 8 DRIVE LEFT	=100/14.3	-X5	10	2	=100+M-8M1		=100/14.3	VIBRATING FEEDER 8 DRIVE LEFT
				PE				

# INTERCONNECTION DIAGRAM

CABLE NAME <b>-14W3</b>	CABLE TYPE <b>OELFLEX FD855CP</b>
-------------------------	-----------------------------------

REMARK	NO. OF CORES <b>4G+Schirm</b>	CROSS SECTION <b>2.5</b>	CABLE LENGTH <b>-</b>
--------	-------------------------------	--------------------------	-----------------------

FUNCTION TEXT	PAGE/PATH	DESTINATION DESIGNATION FROM	CONNECTION	CORE	DESTINATION DESIGNATION TO	CONNECTION	PAGE/PATH	FUNCTION TEXT
VIBRATING FEEDER 8 DRIVE RIGHT	=100/14.4	-X8	4	1	=100+M-8M2	U1	=100/14.4	VIBRATING FEEDER 8 DRIVE RIGHT
VIBRATING FEEDER 8 DRIVE RIGHT	=100/14.4	-X8	5	2	=100+M-8M2	V1	=100/14.5	VIBRATING FEEDER 8 DRIVE RIGHT
VIBRATING FEEDER 8 DRIVE RIGHT	=100/14.4	-X8	6	3	=100+M-8M2	W1	=100/14.5	VIBRATING FEEDER 8 DRIVE RIGHT
VIBRATING FEEDER 8 DRIVE RIGHT	=100/14.5	-X8	PE	PE	=100+M-8M2	PE	=100/14.5	VIBRATING FEEDER 8 DRIVE RIGHT
				SH				

MODIFICAT.	DATE	NAME	NORM	DIN	ORIGIN	REP.F.	REP.T.	KLEEMANN SERIES	K007	= KAB	+
					KLEEMANN GMBH			KLEEMANN MATERIAL NO	M20000111_01	CAE-SYSTEM:	PG. 46
					MOBICAT MC 120 Z US					EPLAN 5.70	PG. 56



# INTERCONNECTION DIAGRAM

TPS\_N\_20.SKN / 2005-07-25

CABLE NAME	-14W4			CABLE TYPE	OELFLEX Tray II				
------------	-------	--	--	------------	-----------------	--	--	--	--

REMARK				NO. OF CORES	3G		CROSS SECTION	1.5		CABLE LENGTH	-	
--------	--	--	--	--------------	----	--	---------------	-----	--	--------------	---	--

FUNCTION TEXT	PAGE/PATH	DESTINATION DESIGNATION FROM	CONNECTION	CORE	DESTINATION DESIGNATION TO	CONNECTION	PAGE/PATH	FUNCTION TEXT
VIBRATING FEEDER 8 DRIVE RIGHT	=100/14.4	-X5	11	1	=100+M-8M2		=100/14.5	VIBRATING FEEDER 8 DRIVE RIGHT
VIBRATING FEEDER 8 DRIVE RIGHT	=100/14.4	-X5	12	2	=100+M-8M2		=100/14.5	VIBRATING FEEDER 8 DRIVE RIGHT
				PE				

DATE	18.Apr.2012	KLEEMANN GMBH		-14W4	KLEEMANN SERIES	K007	= KAB		
EDITED	JHE	MOBICAT MC 120 Z US				KLEEMANN MATERIAL NO	M20000111_01	CAE-SYSTEM: EPLAN 5.70	
CONTR.	D. MALLKOWSKY								
MODIFICAT.	DATE	NAME	NORM	DIN	ORIGIN	REP.F.	REP.T.		





**INTERCONNECTION DIAGRAM**

TPS\_N\_20.SKN / 2005-07-25

CABLE NAME **-36W2** CABLE TYPE **UNITRONIC**

REMARK NO. OF CORES **3+Schirm** CROSS SECTION **0.5** CABLE LENGTH **-**

FUNCTION TEXT	PAGE/PATH	DESTINATION DESIGNATION FROM	CONNECTION	CORE	DESTINATION DESIGNATION TO	CONNECTION	PAGE/PATH	FUNCTION TEXT
				WH				
LIGHT BARRIER CRUSHER	=100/36.3	-XLS	2	BN	=100+M-LT	5	=100/36.3	LIGHT BARRIER CRUSHER
LIGHT BARRIER CRUSHER	=100/36.3	-XLS	1	GN	=100+M-LT	7	=100/36.3	LIGHT BARRIER CRUSHER
				SH				

DATE	18.Apr.2012	KLEEMANN GMBH		-36W2	KLEEMANN SERIES	K007	= KAB	+
EDITED	JHE	MOBICAT MC 120 Z US			KLEEMANN MATERIAL NO	M20000111_01	CAE-SYSTEM: EPLAN 5.70	PG. 49
CONTR.	D. MALLKOWSKY	REP.F.	REP.T.				PG. 56	
MODIFICAT.	DATE	NAME	NORM	DIN	ORIGIN	REP.F.	REP.T.	

# INTERCONNECTION DIAGRAM

TPS\_N\_20.SKN / 2005-07-25

CABLE NAME **-37W1** CABLE TYPE **OELFLEX Tray II**

REMARK NO. OF CORES **4G** CROSS SECTION **-** CABLE LENGTH **-**

FUNCTION TEXT	PAGE/PATH	DESTINATION DESIGNATION FROM	CONNECTION	CORE	DESTINATION DESIGNATION TO	CONNECTION	PAGE/PATH	FUNCTION TEXT
SUPPLY 24V	=100/37.0	-XG	30	1	+M-XG	30	=100/37.0	SUPPLY 24V
SUPPLY 0V	=100/37.1	-XG	31	2	+M-XG	31	=100/37.1	SUPPLY 0V
				3				
				PE				

DATE	18.Apr.2012	KLEEMANN GMBH		 	-37W1	KLEEMANN SERIES	<b>K007</b>	= KAB	
EDITED	JHE	MOBICAT MC 120 Z US				KLEEMANN MATERIAL NO	<b>M20000111_01</b>	CAE-SYSTEM: EPLAN 5.70	PG.
CONTR.	D. MALLKOWSKY	ORIGIN	REP.F.	REP.T.				PG.	<b>56</b>
MODIFICAT.	DATE	NAME	NORM	DIN					

**INTERCONNECTION DIAGRAM**

TPS\_N\_20.SKN / 2005-07-25

CABLE NAME **-37W2** CABLE TYPE **OELFLEX Tray II**

REMARK NO. OF CORES **18G** CROSS SECTION **-** CABLE LENGTH **-**

FUNCTION TEXT	PAGE/PATH	DESTINATION DESIGNATION FROM	CONNECTION	CORE	DESTINATION DESIGNATION TO	CONNECTION	PAGE/PATH	FUNCTION TEXT
				1				
START	=100/37.4	-XG	50	2	+M-XG	50	=100/37.4	START
RELEASE	=100/37.7	-XG	3	3	+M-XG	3	=100/37.7	RELEASE
				4				
OIL PRESSURE	=100/38.6	-XG	5.1	5	+M-XG	5.1	=100/38.6	OIL PRESSURE
TEMPERATURE INDICATION 2: 100°C	=100/38.4	-XG	77	6	+M-XG	77	=100/38.4	TEMPERATURE INDICATION 2: 100°C
TEMPERATURE	=100/38.6	-XG	7.1	7	+M-XG	7.1	=100/38.6	TEMPERATURE
COOLING WATER LOW LEVEL	=100/38.8	-XG	8	8	+M-XG	8	=100/38.8	COOLING WATER LOW LEVEL
				9				
FUEL LEVEL	=100/38.3	-XG	18	10	+M-XG	18	=100/38.3	FUEL LEVEL
AIR FILTER PLUGGES	=100/38.5	-XG	11	11	+M-XG	11	=100/38.5	AIR FILTER PLUGGES
RESET SERVICE	=100/39.6	-XG	22	12	+M-XG	28	=100/39.6	RESET SERVICE
SERVICE LAMP	=100/39.7	-XG	23	13	+M-XG	29	=100/39.7	SERVICE LAMP
DIAGNOSTIC LAMP	=100/39.7	-XG	24	14	+M-XG	32	=100/39.7	DIAGNOSTIC LAMP
WARNING LAMP	=100/39.8	-XG	25	15	+M-XG	33	=100/39.8	WARNING LAMP
				16				
				17				
				PE				

DATE	18.Apr.2012	KLEEMANN GMBH	 	-37W2	KLEEMANN SERIES	K007	= KAB	+
EDITED	JHE	MOBICAT MC 120 Z US				KLEEMANN MATERIAL NO	M20000111_01	CAE-SYSTEM: EPLAN 5.70
CONTR.	D. MALLKOWSKY							PG. 56
MODIFICAT.	DATE	NAME	NORM	DIN	ORIGIN	REP.F.	REP.T.	

# INTERCONNECTION DIAGRAM

TPS\_N\_20.SKN / 2005-07-25

CABLE NAME **-41W1** CABLE TYPE **OELFLEX Tray II**

REMARK NO. OF CORES **18G** CROSS SECTION **-** CABLE LENGTH **-**

FUNCTION TEXT	PAGE/PATH	DESTINATION DESIGNATION FROM	CONNECTION	CORE	DESTINATION DESIGNATION TO	CONNECTION	PAGE/PATH	FUNCTION TEXT
	=100/41.1	-XF	1	1			=100/41.1	
VIBRATING CHUTE FASTER (RADIO)	=100/41.5	-XF	2	2			=100/41.1	
INSTALLATION OFF (RADIO)	=100/41.2	-XF	3	3			=100/41.1	
INSTALLATION OFF (RADIO)	=100/41.2	-XF	4	4			=100/41.1	
				5				
	=100/41.1	-XF	6	6			=100/41.1	
	=100/41.1	-XF	7	7			=100/41.1	
VIBRATING CHUTE SLOWER (RADIO)	=100/41.4	-XF	8	8			=100/41.1	
VIBRATING CHUTE + SCREEN OFF(REMOTE)	=100/41.3	-XF	9	9			=100/41.1	
VIBRATING CHUTE FASTER (RADIO)	=100/41.4	-XF	10	10			=100/41.1	
VIBRATING CHUTE + SCREEN ON(REMOTE)	=100/41.2	-XF	11	11			=100/41.1	
				12				
RUN CHAIN RIGHT (REMOTE)	=100/41.6	-X22	C1	13	=100+M-20A2	13	=100/41.1	
RUN CHAIN RIGHT (REMOTE)	=100/41.7	-X22	D1	14	=100+M-20A2	14	=100/41.1	
RUN CHAIN LEFT (REMOTE)	=100/41.6	-X22	C2	15	=100+M-20A2	15	=100/41.1	
RUN CHAIN LEFT (REMOTE)	=100/41.5	-X22	D2	16	=100+M-20A2	16	=100/41.1	
				17				
				PE				

DATE	18.Apr.2012	KLEEMANN GMBH	 	-41W1	KLEEMANN SERIES	K007	= KAB	+
EDITED	JHE	MOBICAT MC 120 Z US				KLEEMANN MATERIAL NO	M20000111_01	CAE-SYSTEM: EPLAN 5.70
CONTR.	D. MALLKOWSKY							PG. 56
MODIFICAT.	DATE	NAME	NORM	DIN	ORIGIN	REP.F.	REP.T.	

**INTERCONNECTION DIAGRAM**

TPS\_N\_20.SKN / 2005-07-25

CABLE NAME <b>-41W2</b>	CABLE TYPE <b>OELFLEX 491P</b>
-------------------------	--------------------------------

REMARK	NO. OF CORES <b>5G</b>	CROSS SECTION <b>-</b>	CABLE LENGTH <b>-</b>
--------	------------------------	------------------------	-----------------------

FUNCTION TEXT	PAGE/PATH	DESTINATION DESIGNATION FROM	CONNECTION	CORE	DESTINATION DESIGNATION TO	CONNECTION	PAGE/PATH	FUNCTION TEXT
RUN CHAIN LEFT (MANUAL)	=100/41.8	-X22	A2	1	=100+M-Y5B	A2	=100/41.7	RUN CHAIN RIGHT (REMOTE)
RUN CHAIN LEFT (MANUAL)	=100/41.8	-X22	B2	2	=100+M-Y5B	B2	=100/41.7	RUN CHAIN RIGHT (REMOTE)
RUN CHAIN LEFT (REMOTE)	=100/41.6	-X22	C2	3	=100+M-Y5B	C2	=100/41.7	RUN CHAIN RIGHT (REMOTE)
RUN CHAIN LEFT (REMOTE)	=100/41.5	-X22	D2	4	=100+M-Y5B	D2	=100/41.7	RUN CHAIN RIGHT (REMOTE)
				PE				

DATE	18.Apr.2012	KLEEMANN GMBH		-41W2	KLEEMANN SERIES	K007	= KAB	+	
EDITED	JHE	MOBICAT MC 120 Z US			KLEEMANN MATERIAL NO	M20000111_01	CAE-SYSTEM:	EPLAN 5.70	PG. 53
CONTR.	D. MALLKOWSKY	ORIGIN		REP.F.	REP.T.				PG. 56



INTERCONNECTION DIAGRAM

CABLE NAME -41W4	CABLE TYPE OELFLEX Tray II
------------------	----------------------------

REMARK	NO. OF CORES 7G	CROSS SECTION -	CABLE LENGTH -
--------	-----------------	-----------------	----------------

FUNCTION TEXT	PAGE/PATH	DESTINATION DESIGNATION FROM	CONNECTION	CORE	DESTINATION DESIGNATION TO	CONNECTION	PAGE/PATH	FUNCTION TEXT
EINSPEISUNG 24V DC	=100/41.7	-X22	1	1	+M-XF1	1	=100/41.7	EINSPEISUNG 24V DC
EINSPEISUNG 0V DC	=100/41.9	-X22	2	2	+M-XF1	2	=100/41.9	EINSPEISUNG 0V DC
RUN CHAIN LEFT (MANUAL)	=100/41.8	-X22	B2	3	+M-XF1	3	=100/41.8	RUN CHAIN LEFT (MANUAL)
RUN CHAIN LEFT (MANUAL)	=100/41.8	-X22	A2	4	+M-XF1	4	=100/41.8	RUN CHAIN LEFT (MANUAL)
RUN CHAIN RIGHT (MANUAL)	=100/41.7	-X22	B1	5	+M-XF1	5	=100/41.7	RUN CHAIN RIGHT (MANUAL)
RUN CHAIN RIGHT (MANUAL)	=100/41.7	-X22	A1	6	+M-XF1	6	=100/41.7	RUN CHAIN RIGHT (MANUAL)
				PE				

			DATE 18.Apr.2012	KLEEMANN GMBH	 	-41W4	KLEEMANN SERIES K007	= KAB	+
			EDITED JHE	MOBICAT MC 120 Z US			KLEEMANN MATERIAL NO M20000111_01	CAE-SYSTEM:	PG. 55
			CONTR. D. MALLKOWSKY					EPLAN 5.70	PG. 56
MODIFICAT.	DATE	NAME	NORM DIN	ORIGIN	REP.F.	REP.T.			



# INTERCONNECTION DIAGRAM

TPS\_N\_20.SKN / 2005-07-25

CABLE NAME -41W5				CABLE TYPE OELFLEX Tray II					
REMARK				NO. OF CORES 3G		CROSS SECTION -		CABLE LENGTH -	

FUNCTION TEXT	PAGE/PATH	DESTINATION DESIGNATION FROM	CONNECTION	CORE	DESTINATION DESIGNATION TO	CONNECTION	PAGE/PATH	FUNCTION TEXT
BRACKE VALVE	=100/41.9	-XB	1	1	=100+M-Y3	1	=100/41.9	BRACKE VALVE
BRACKE VALVE	=100/41.9	-XB	2	2	=100+M-Y3	2	=100/41.9	BRACKE VALVE
				PE				

DATE	18.Apr.2012	KLEEMANN GMBH		-41W5	KLEEMANN SERIES	K007	= KAB	+	
EDITED	JHE	MOBICAT MC 120 Z US			KLEEMANN MATERIAL NO	M20000111_01	CAE-SYSTEM:	EPLAN 5.70	PG. 56
CONTR.	D. MALLKOWSKY	ORIGIN			REP.F.	REP.T.			PG. 56

# Part's list

TPLSTK02 02.04.2003

Component designation	Amount	DESIGNATION	Manufacturer	Article number	Page/Path	Model number
-XOUT	1	Anbaueinheit 16-pol. mit 2 Buegeln	ILME GmbH	M10020941	=A0/19.6	CHI 16
-XOUT	1	Tuellengehaeuse 16-pol. mit Bolzen, seitlicher Kabelausgang	ILME GmbH	M10011806	=A0/19.6	CHO 16
-XOUT	1	Buchseneinsatz 16-polig +PE 16A max, 400V	ILME GmbH	M10011811	=A0/19.6	CNF 16
-XOUT	1	Stifteinsatz 16-polig +PE 16A max, 400V	ILME GmbH	M10011812	=A0/19.6	CNM 16
-3X2	1	Tuellengehaeuse 4-pol. +PE mit Buegel und Verschraubung, Metall	ILME GmbH	M10011803	=A0/19.6	CKA 03 VGS
-3X2	1	Stifteinsatz 4-polig +PE 10A max, 250V	ILME GmbH	M10011804	=A0/19.6	CKM 04
-3X2	1	Buchseneinsatz 4-polig +PE 10A max, 250V	ILME GmbH	M10011805	=A0/19.6	CKF 04
-4X1	1	Stifteinsatz 4+2-polig +PE 80A max+16A max, 400V	ILME GmbH	CXM 4/2	=A0/19.6	CXM 4/2
-4X1	1	Buchseneinsatz 4+2-polig +PE 80A max+16A max, 400V	ILME GmbH	CXF 4/2	=A0/19.6	CXF 4/2
-4X1	1	Anbaueinheit 16-pol. mit 2 Buegeln	ILME GmbH	M10020941	=A0/19.6	CHI 16
-4X1	1	Tuellengehaeuse M32 mit Bolzen für 2 Bügel	ILME GmbH	MHO 16.32	=A0/19.6	MHO 16.32
-4X2	1	Stifteinsatz 4-polig +PE 10A max, 250V	ILME GmbH	M10011804	=A0/19.6	CKM 04
-4X2	1	Buchseneinsatz 4-polig +PE 10A max, 250V	ILME GmbH	M10011805	=A0/19.6	CKF 04
-4X2	1	Anbaueinheit ohne Kabelausgang	ILME GmbH	CKAX 03 IA	=A0/19.6	CKAX 03 IA
-4X2	1	Tuellengehaeuse mit Bolzen	ILME GmbH	MKA V20	=A0/19.6	MKA V20
=100-0P1	1	Amperemeter 0-800A	Yokogawa	251340LSSNUL	=100/1.1	251340LSSNUL
=100-0T02	1	Summenstromwandler 500mA fuer FI-Relais Typ MFR	Doepke	MFIW 105/0,5	=100/1.1	MFIW 105/0,5
=100-0Q1	1	Leistungsschalter 3p 600A BG3 NZMN3-AE600-NA	Moeller	M00000003	=100/1.1	NZMN3-AE600-NA
=100-0Q1	1	Hauptschalterbausatz f. NZM3, N3	Moeller	NZM3-XTVDVR-NA	=100/1.1	NZM3-XTVDVR-NA
=100-0Q1	1	Unterspannungsausloeser mit 2 VHI NZM2/3-XUHIVC380-440AC	Moeller	M10017491	=100/1.1	NZM2/3-XUHIVC380-440AC
=100-0Q1	1	Kontaktelement 1S Front M22-CK10	Moeller	M10016214	=100/1.1	M22-CK10
=100-0T01	1	Stromwandler 800/5A	IT INC	58RBT-801	=100/1.1	58RBT-801
=100-0F00	1	Sicherungshalter 2-pol. 600V, 30A	Woehner GmbH & Co. KG	31 296	=100/1.2	31 296
=100-0F00	2	Sicherungseinsatz Gr.10 x 38 2A, 600V AC	Woehner GmbH & Co. KG	M10025367	=100/1.2	31 245
=100-PE	2	Sammelschienenhalter 1polig	Rittal GmbH & Co. KG	SV 9340.030	=100/1.2	SV 9340.030
=100-0F01	1	FI-Steuerschalter 2S, 500V, 16A	Doepke	M10016345	=100/1.3	MFR
=100-0SS	1	Schlüsselschalter, O-I Ronis 1S mit Halter	Siemens	M10021350	=100/1.6	3SB32 02-4AD11-0CC0
=100-0SS	1	Schildtraeger	Siemens	3SB39 25-0AV	=100/1.6	3SB39 25-0AV
=100-TS1	1	Positionsschalter 1S+1OE	Siemens	3SE2 200-1C	=100/1.7	3SE2 200-1C
=100-TS2	1	Positionsschalter 1S+1OE	Siemens	3SE2 200-1C	=100/1.7	3SE2 200-1C
=100-TS3	1	Positionsschalter 1S+1OE	Siemens	3SE2 200-1C	=100/1.7	3SE2 200-1C
=100-TS4	1	Positionsschalter 1S+1OE	Siemens	3SE2 200-1C	=100/1.7	3SE2 200-1C
=100-0F06	1	Sicherungshalter 1-pol. 600V, 30A	Woehner GmbH & Co. KG	31 295	=100/3.1	31 295
=100-0F06	1	Sicherungseinsatz Gr.10 x 38 6A, 600V AC	Woehner GmbH & Co. KG	M10025368	=100/3.1	31 247
=100-0F07	1	Sicherungshalter 1-pol. 600V, 30A	Woehner GmbH & Co. KG	31 295	=100/3.3	31 295
=100-0F07	1	Sicherungseinsatz Gr.10 x 38 6A, 600V AC	Woehner GmbH & Co. KG	M10025368	=100/3.3	31 247
=100-0F08	1	Sicherungshalter 1-pol. 600V, 30A	Woehner GmbH & Co. KG	31 295	=100/3.5	31 295
=100-0F08	1	Sicherungseinsatz Gr.10 x 38 10A, 600V AC	Woehner GmbH & Co. KG	M10025369	=100/3.5	31 248
=100-SX	1	Knebel 2 Schalterstellungen, unbeleuchtet verrastend, Schaltwinkel 50°	Siemens	M10015574	=100/3.7	3SB30 00-2KA11
=100-SX	1	Schutzkappe für Knebel	Siemens	3SB39 21-0BA	=100/3.7	3SB39 21-0BA
=100-SX	1	Schildtraeger	Siemens	3SB39 25-0AV	=100/3.7	3SB39 25-0AV
=100-KX	1	Stecksockel mit Relais 2 Wechsler 250V AC/8A Spule 24V DC	Wago GmbH & Co. KG	M10019133 + M10019138	=100/3.7	788-312
=100-0F03	1	Sicherungshalter 3-pol. 600V, 30A	Woehner GmbH & Co. KG	31 297	=100/4.1	31 297
=100-0F03	3	Sicherungseinsatz Gr.10 x 38 30A, 600V AC	Woehner GmbH & Co. KG	M10025373	=100/4.1	31 252
=100-0F04	1	FI-Schutzschalter 4polig 40A	ABB AG	F204A-40/0,03	=100/4.1	F204A-40/0,03
=100-0X5	1	Einbauschukosteckdose Typ: 60380MZ 5-Pol 480V/30A	Mennekes	M10019713	=100/4.1	ME 530R7W
=100-0F0	1	Sicherungshalter AMBUS EasySwitch 3-pol. 690V, 125A	Woehner GmbH & Co. KG	31 123	=100/5.1	31 123
=100-0F0	3	Sicherungseinsatz 22x58 100A, 690V, gG	Woehner GmbH & Co. KG	31 203	=100/5.1	31 203
=100-0F0	1	CB Geraeteadapter 125A, 600V, UL 508	Rittal GmbH & Co. KG	2196726	=100/5.1	SV 9342.550
=100-0X1	1	Einbauschukosteckdose Typ: 60063MZ 4-Pol 480V/100A	Mennekes	M10019712	=100/5.1	ME 5100R7W

=KAB/56

2

MODIFICAT.	DATE	NAME	NORM	DIN	ORIGIN	REP.F.	REP.T.						
			DATE	18.Apr.2012	KLEEMANN GMBH			 	STUECKLISTE	KLEEMANN SERIES	K007	= STK	+
			EDITED	JHE	MOBICAT MC 120 Z US				KLEEMANN MATERIAL NO	M20000111_01	CAE-SYSTEM: EPLAN 5.70	PG.	1
			CONTR.	D. MALLKOWSKY							PG.	12	

# Part's list

TPLSTK02 02.04.2003

Component designation	Amount	DESIGNATION	Manufacturer	Article number	Page/Path	Model number
=100-0F05	1	Sicherungshalter 1-pol. 600V, 30A	Woehner GmbH & Co. KG	31 295	=100/5.3	31 295
=100-0F05	1	Sicherungseinsatz Gr.10 x 38 15A, 600V AC	Woehner GmbH & Co. KG	M10025370	=100/5.3	31 249
=100-0FI05	1	FI-Schutzschalter 2polig 25A	ABB AG	F202A-25/0,03	=100/5.3	F202A-25/0,03
=100-0X4	1	Steckdose 1-Pol+N+PE 125V/15A	ABL SURSUM	UL12505	=100/5.3	UL12505
=100-0F1	1	Sicherungshalter 2-pol. 600V, 30A	Woehner GmbH & Co. KG	31 296	=100/5.5	31 296
=100-0F1	2	Sicherungseinsatz Gr.10 x 38 15A, 600V AC	Woehner GmbH & Co. KG	M10025370	=100/5.5	31 249
=100-0F1	1	OM Adapter 32A,690V, UL 508	Rittal GmbH & Co. KG	M10025431	=100/5.5	SV 9340.510
=100-0T1	1	Transformator 1-phasig 1600VA Prim. 400V AC Sek. 2x115V AC	Block GmbH & Co. KG	STU1600/4/23	=100/5.5	STU1600/4/23
=100-0F1.3	1	Sicherungsautomat 1-polig Typ C 2A 400V AC/220V DC	Siemens	M10019972	=100/5.5	5SY6 102-7
=100-0F1.3	1	Hilfsschalter 1S 1OE fuer LS-Schalter T=70mm	Siemens	M10019130	=100/5.5	5ST3 010
=100-0F02	1	Sicherungsautomat 2-polig Typ C 2A 440V AC/60V DC	Siemens	M10019162	=100/5.7	5SY6 202-7
=100-0P2	1	Voltmeter 500V	Yokogawa	251344SFSFUL	=100/5.7	251344SFSFUL
=100-0S00	1	Pilzdrucktaster rot 1OE,rastend,Drehentriegelung	Siemens	M10015479	=100/6.6	3SB32 03-1HA20-0CC0
=100-0S00	2	Schaltelement mit 1 Schaltglied 1S	Siemens	M10017540	=100/6.6	3SB34 03-0B
=100-0S00	1	Schutzkappe fuer Pilz-Drucktaster	Siemens	3SB19 02-2BH	=100/6.6	3SB19 02-2BH
=100-0S00	1	Schildtraeger fuer NOT-AUS Pilz-Drucktaster	Moeller	M22-XAK1	=100/6.6	M22-XAK1
=100-D1	1	Schaltgeraet, 230V 3S+1OE	Pilz GmbH & Co.	M10015064	=100/6.8	PNOZ X4
=100-0F2	1	Sicherungshalter 1-pol. 600V, 30A	Woehner GmbH & Co. KG	31 295	=100/7.1	31 295
=100-0F2	1	Sicherungseinsatz Gr.10 x 38 10A, 600V AC	Woehner GmbH & Co. KG	M10025369	=100/7.1	31 248
=100-K0.1	1	Hilfsschuetz SIRIUS 4S 24VDC Cage Clamp-Anschluss, o.Varistor	Siemens	M10018964	=100/7.1	3RH11 40-2BB40
=100-0F3	1	Sicherungsautomat 1-polig Typ C 6A 400V AC/220V DC	Siemens	M10019164	=100/7.3	5SY6 106-7
=100-0F3	1	Hilfsschalter 1S 1OE fuer LS-Schalter T=70mm	Siemens	M10019130	=100/7.3	5ST3 010
=100-0S1	1	Schluesselschalter, O-I Ronis 1S mit Halter	Siemens	M10021350	=100/7.3	3SB32 02-4AD11-0CC0
=100-0S1	1	Schildtraeger	Siemens	3SB39 25-0AV	=100/7.3	3SB39 25-0AV
=100-0K1	1	Motorschuetz, 4kW/400V 3H 1S 24V DC ohne Varistor, Cage-Clamp	Siemens	M10014900	=100/7.3	3RT10 16-2BB41
=100-0K1	1	Hilfsschalterblock 2S+2OE Cage-Clamp-Anschluss	Siemens	M10019973	=100/7.3	3RH19 11-2FA22
=100-GF2	1	Sicherungshalter 1-pol. 600V, 30A	Woehner GmbH & Co. KG	31 295	=100/7.5	31 295
=100-GF2	1	Sicherungseinsatz Gr.10 x 38 15A, 600V AC	Woehner GmbH & Co. KG	M10025370	=100/7.5	31 249
=100+M-1H2	1	Rueckfahrwarner 24V DC	Bosch	A65	=100/7.6	A65
=100-0F4	1	Sicherungshalter 1-pol. 600V, 30A	Woehner GmbH & Co. KG	31 295	=100/7.6	31 295
=100-0F4	1	Sicherungseinsatz Gr.10 x 38 6A, 600V AC	Woehner GmbH & Co. KG	M10025368	=100/7.6	31 247
=100+M-00H2	1	Sirene 24V DC, 0,5A	Funke+Huster GmbH	M10011815	=100/7.7	KS 24
=100+M-00H3	1	Blitzlicht	Telemecanique	M10011814	=100/7.8	XVA L 6B5 C024
=100-1P1	1	Amperemeter 400/800/5A	Langer	RQ 72 E 400/800/5A	=100/8.1	RQ 72 E 400/800/5A
=100-1K01	1	Ueberwachungsrelais 1 Wechsler, 24-240V AC/DC, 0,1-10A AC/DC	Siemens	M10014275	=100/8.1	3UG46 22-2AW30
=100-1T1	1	Stromwandler AC 32 400/5A	Langer	TAC 32 400/5A	=100/8.3	TAC 32 400/5A
=100-1K0	1	Elektronisches Motorschutzrelais 2S 2OE	Klöckner Moeller	M10013726	=100/8.6	ZEV
=100-1K0	1	Stromsensor 40-820A	Klöckner Moeller	M10019256	=100/8.6	ZEV-XSW-820
=100-1K0	1	Verbindungsleitung f.ZEV-XSW-25, 65, 145, 820 Laenge 800mm	Moeller	M10019257	=100/8.6	ZEV-XVK-80
=100-1KC1	1	Motorschuetz, 90kW/400V 3H, 2S+2OE, 110-127V AC/DC, mit Varistor	Siemens	M10020791	=100/9.1	3RT10 56-2AF36
=100-1KT1	1	Zeitrelais 24V DC/AC,100...127V AC 1S+1S verzoegert, Cage Clamp	Siemens	3RP15 76-2NQ30	=100/9.3	3RP15 76-2NQ30
=100-1KC2	1	Motorschuetz, 90kW/400V 3H, 2S+2OE, 110-127V AC/DC, mit Varistor	Siemens	M10020791	=100/9.4	3RT10 56-2AF36
=100-1KC3	1	Motorschuetz, 75kW/400V 3H, 2S+2OE, 110-127V AC/DC, mit Varistor	Siemens	M10020792	=100/9.6	3RT10 55-2AF36
=100-2Q1	1	Leistungsschalter 4,5-6,3A mit Hilfsschalter 1S+1OE	Siemens	M10013566	=100/10.1	3RV10 11-1GA15
=100-2Q1	1	OM Adapter 25A,690V, UL 508	Rittal GmbH & Co. KG	2196964	=100/10.1	SV 9340.310
=100-2Q1	1	Tragschiene 45mm	Rittal GmbH & Co. KG	2196728	=100/10.1	SV 9342.850
=100-2F1	1	Sicherungsautomat 3-polig Typ C 25A 440V AC/60V DC	Siemens	M10019129	=100/10.4	5SY6 325-7
=100-2F1	1	Hilfsschalter 1S 1OE fuer LS-Schalter T=70mm	Siemens	M10019130	=100/10.4	5ST3 010
=100-2F1	1	OM Adapter 32A,690V	Rittal GmbH & Co. KG	2196715	=100/10.4	SV 9340.460
=100-3Q1	1	Leistungsschalter 11-16A mit Hilfsschalter	Siemens	M10013570	=100/10.7	3RV10 21-4AA15

1

3

DATE		18.Apr.2012		KLEEMANN GMBH		 	STUECKLISTE		KLEEMANN SERIES	K007	= STK	+
EDITED		JHE		MOBICAT MC 120 Z US			KLEEMANN MATERIAL NO		M20000111_01		CAE-SYSTEM: EPLAN 5.70	PG. 2
CONTR.		D. MALLKOWSKY		ORIGIN			REP.F.		REP.T.		PG. 12	
MODIFICAT.	DATE	NAME	NORM	DIN	ORIGIN	REP.F.	REP.T.					

# Part's list

TPLSTK02 02.04.2003

Component designation	Amount	DESIGNATION	Manufacturer	Article number	Page/Path	Model number
=100-3Q1	1	OM Adapter 25A,690V, UL 508	Rittal GmbH & Co. KG	2196964	=100/10.7	SV 9340.310
=100-3Q1	1	Tragschiene 45mm	Rittal GmbH & Co. KG	2196728	=100/10.7	SV 9342.850
=100-3X1	1	Einbauschukosteckdose Typ: 60336MZ 5-Pol 480V/20A	Mennekes	ME 520R7W	=100/10.7	ME 520R7W
=100-4Q1	1	Leistungsschalter 22-32A ohne Hilfsschalter,fuer Motorschutz	Siemens	M10018521	=100/11.1	3RV10 31-4EA10
=100-4Q1	1	OM Adapter 65A,690V, UL 508	Rittal GmbH & Co. KG	SV 9340.430	=100/11.1	SV 9340.430
=100-4Q1	1	Tragschiene 45mm	Rittal GmbH & Co. KG	2196728	=100/11.1	SV 9342.850
=100-4K0	1	Elektronisches Motorschutzrelais 2S 2OE	Klöckner Moeller	M10013726	=100/11.3	ZEV
=100-4K0	1	Stromsensor 2-65A	Klöckner Moeller	M10013727	=100/11.3	ZEV-XSW-65
=100-4K0	1	Verbindungsleitung f.ZEV-XSW-25, 65, 145, 820 Laenge 200mm	Moeller	M10013728	=100/11.3	ZEV-XVK-20
=100-5Q1	1	Leistungsschalter 7-10A mit Hilfsschalter	Siemens	M10013568	=100/11.4	3RV10 11-1JA15
=100-5Q1	1	OM Adapter 25A,690V, UL 508	Rittal GmbH & Co. KG	2196964	=100/11.4	SV 9340.310
=100-5Q1	1	Tragschiene 45mm	Rittal GmbH & Co. KG	2196728	=100/11.4	SV 9342.850
=100-5K0	1	Elektronisches Motorschutzrelais 2S 2OE	Klöckner Moeller	M10013726	=100/11.5	ZEV
=100-5K0	1	Stromsensor 1-25A	Klöckner Moeller	M10019255	=100/11.5	ZEV-XSW-25
=100-5K0	1	Verbindungsleitung f.ZEV-XSW-25, 65, 145, 820 Laenge 200mm	Moeller	M10013728	=100/11.5	ZEV-XVK-20
=100-5Q2	1	Leistungsschalter 7-10A mit Hilfsschalter	Siemens	M10013568	=100/11.7	3RV10 11-1JA15
=100-5Q2	1	OM Adapter 25A,690V, UL 508	Rittal GmbH & Co. KG	2196964	=100/11.7	SV 9340.310
=100-5Q2	1	Tragschiene 45mm	Rittal GmbH & Co. KG	2196728	=100/11.7	SV 9342.850
=100-5K0.1	1	Elektronisches Motorschutzrelais 2S 2OE	Klöckner Moeller	M10013726	=100/11.8	ZEV
=100-5K0.1	1	Stromsensor 1-25A	Klöckner Moeller	M10019255	=100/11.8	ZEV-XSW-25
=100-5K0.1	1	Verbindungsleitung f.ZEV-XSW-25, 65, 145, 820 Laenge 200mm	Moeller	M10013728	=100/11.8	ZEV-XVK-20
=100-6Q1	1	Leistungsschalter 11-16A mit Hilfsschalter	Siemens	M10013570	=100/12.1	3RV10 21-4AA15
=100-6Q1	1	OM Adapter 25A,690V, UL 508	Rittal GmbH & Co. KG	2196964	=100/12.1	SV 9340.310
=100-6Q1	1	Tragschiene 45mm	Rittal GmbH & Co. KG	2196728	=100/12.1	SV 9342.850
=100-7F1	1	Sicherungsautomat 3-polig Typ C 63A 440V AC/60V DC	Siemens	M10019124	=100/12.4	5SY6 363-7
=100-7F1	1	Hilfsschalter 1S 1OE fuer LS-Schalter T=70mm	Siemens	M10019130	=100/12.4	5ST3 010
=100-7F1	1	OM Adapter 65A, 690V	Rittal GmbH & Co. KG	SV 9340.410	=100/12.4	SV 9340.410
=100-7K0	1	Elektronisches Motorschutzrelais 2S 2OE	Klöckner Moeller	M10013726	=100/12.5	ZEV
=100-7K0	1	Stromsensor 2-65A	Klöckner Moeller	M10013727	=100/12.5	ZEV-XSW-65
=100-7K0	1	Verbindungsleitung f.ZEV-XSW-25, 65, 145, 820 Laenge 200mm	Moeller	M10013728	=100/12.5	ZEV-XVK-20
=100-9Q1	1	Leistungsschalter 7-10A mit Hilfsschalter	Siemens	M10013568	=100/13.1	3RV10 11-1JA15
=100-9Q1	1	OM Adapter 25A,690V, UL 508	Rittal GmbH & Co. KG	2196964	=100/13.1	SV 9340.310
=100-9Q1	1	Tragschiene 45mm	Rittal GmbH & Co. KG	2196728	=100/13.1	SV 9342.850
=100-10Q1	1	Leistungsschalter 4,5-6,3A mit Hilfsschalter 1S+1OE	Siemens	M10013566	=100/13.3	3RV10 11-1GA15
=100-10Q1	1	OM Adapter 32A,690V, UL 508	Rittal GmbH & Co. KG	M10025431	=100/13.3	SV 9340.510
=100-10Q1	1	Tragschiene 45mm	Rittal GmbH & Co. KG	2196728	=100/13.3	SV 9342.850
=100-13Q1	1	Leistungsschalter 0,22-0,32A mit Hilfsschalter	Siemens	M10015340	=100/13.6	3RV10 11-0DA15
=100-13Q1	1	OM Adapter 25A,690V, UL 508	Rittal GmbH & Co. KG	2196964	=100/13.6	SV 9340.310
=100-8Q1	1	Steuerschalter 4-pol 12kW 400V 32A	Moeller	M10013874	=100/14.1	T3-4-8223/E
=100-8A1	1	Frequenzumrichter 380-480V, 25/29A, 50-60Hz, 11/15kW	Control Techniques	M20000268	=100/14.2	SK 2403
=100-8F1	1	Sicherungsautomat 3-polig Typ C 32A 440V AC/60V DC	Siemens	M10019128	=100/14.2	5SY6 332-7
=100-8F1	1	Hilfsschalter 1S 1OE fuer LS-Schalter T=70mm	Siemens	M10019130	=100/14.2	5ST3 010
=100-8F1	1	OM Adapter 32A,690V	Rittal GmbH & Co. KG	2196715	=100/14.2	SV 9340.460
=100-8L1	1	Netzdrossel 28,8A, max.600V 50-60Hz	Control Techniques	KDD 0,4/N/600V/28,8A/4UK	=100/14.2	KDD 0,4/N/600V/28,8A/4UK
=100-8F2	1	Ueberlastrelais 7-10A, 1S+1OE f.Einzelaufstellung	Siemens	M10014903	=100/14.2	3RU1116-1JC1
=100-8F3	1	Ueberlastrelais 7-10A, 1S+1OE f.Einzelaufstellung	Siemens	M10014903	=100/14.4	3RU1116-1JC1
=100-RB	1	Bremswiderstand SP 100W 400V 37,5 Ohm	Control Techniques	M10020877	=100/14.7	SP
=100-8K0	1	Thermischer Maschinenschutz, 2 LED 1S+1OE, 24V DC, Cage Clamp-Anschluss	Siemens	M10014273	=100/15.3	3RN10 10-2CB00
=100-SC	1	Knebel 2 Schalterstellungen, verrastend, schwarz, 1S	Siemens	M10021302	=100/17.1	3SB32 02-2KA11-0CC0
=100-SC	1	Schutzkappe für Knebel	Siemens	3SB39 21-0BA	=100/17.1	3SB39 21-0BA

2

4

DATE	18.Apr.2012	KLEEMANN GMBH		 	STUECKLISTE	KLEEMANN SERIES	K007	= STK	+	
EDITED	JHE	MOBICAT MC 120 Z US				KLEEMANN MATERIAL NO	M20000111_01	CAE-SYSTEM: EPLAN 5.70	PG.	3
CONTR.	D. MALLKOWSKY					REP. T.			PG.	12
MODIFICAT.	DATE	NAME	NORM	DIN	ORIGIN	REP.F.				





# Part's list

TPLSTK02 02.04.2003

Component designation	Amount	DESIGNATION	Manufacturer	Article number	Page/Path	Model number
=100-4S1	1	Schildtraeger	Siemens	3SB39 25-0AV	=100/25.1	3SB39 25-0AV
=100-5S1	1	Leuchtdrucktaster gruen, LED integriert	Siemens	M10020706	=100/25.2	3SB32 45-0AA41-0CC0
=100-5S1	1	Schutzkappe	Siemens	3SB39 21-0AH	=100/25.2	3SB39 21-0AH
=100-5S1	1	Schildtraeger	Siemens	3SB39 25-0AV	=100/25.2	3SB39 25-0AV
=100-6S1	1	Leuchtdrucktaster gruen, LED integriert	Siemens	M10020706	=100/25.3	3SB32 45-0AA41-0CC0
=100-6S1	1	Schutzkappe	Siemens	3SB39 21-0AH	=100/25.3	3SB39 21-0AH
=100-6S1	1	Schildtraeger	Siemens	3SB39 25-0AV	=100/25.3	3SB39 25-0AV
=100-7S1	1	Leuchtdrucktaster gruen, LED integriert	Siemens	M10020706	=100/25.4	3SB32 45-0AA41-0CC0
=100-7S1	1	Schutzkappe	Siemens	3SB39 21-0AH	=100/25.4	3SB39 21-0AH
=100-7S1	1	Schildtraeger	Siemens	3SB39 25-0AV	=100/25.4	3SB39 25-0AV
=100-8S1	1	Leuchtdrucktaster gruen, LED integriert	Siemens	M10020706	=100/25.5	3SB32 45-0AA41-0CC0
=100-8S1	1	Schutzkappe	Siemens	3SB39 21-0AH	=100/25.5	3SB39 21-0AH
=100-8S1	1	Schildtraeger	Siemens	3SB39 25-0AV	=100/25.5	3SB39 25-0AV
=100-10S1	1	Leuchtdrucktaster gruen, LED integriert	Siemens	M10020706	=100/25.7	3SB32 45-0AA41-0CC0
=100-10S1	1	Schutzkappe	Siemens	3SB39 21-0AH	=100/25.7	3SB39 21-0AH
=100-10S1	1	Schildtraeger	Siemens	3SB39 25-0AV	=100/25.7	3SB39 25-0AV
=100-9S1	1	Leuchtdrucktaster gruen, LED integriert	Siemens	M10020706	=100/26.4	3SB32 45-0AA41-0CC0
=100-9S1	1	Schutzkappe	Siemens	3SB39 21-0AH	=100/26.4	3SB39 21-0AH
=100-9S1	1	Schildtraeger	Siemens	3SB39 25-0AV	=100/26.4	3SB39 25-0AV
=100-S5.2	1	Leuchtdrucktaster gelb, LED integriert	Siemens	3SB32 45-0AA31-0CC0	=100/29.3	3SB32 45-0AA31-0CC0
=100-S5.2	1	Schutzkappe	Siemens	3SB39 21-0AH	=100/29.3	3SB39 21-0AH
=100-S5.2	1	Schildtraeger	Siemens	3SB39 25-0AV	=100/29.3	3SB39 25-0AV
=100+8S	1	Knebel 3 Schalterstellungen,	Siemens	M10021301	=100/29.7	3SB32 10-2EA11-0CC0
=100+8S	1	Schutzkappe	Siemens	3SB39 21-0BA	=100/29.7	3SB39 21-0BA
=100+8S	1	Schildtraeger	Siemens	3SB39 25-0AV	=100/29.7	3SB39 25-0AV
=100-7KC1	1	Motorschuetz 15kW/400V	Siemens	M10013766	=100/32.1	3RT10 34-3BB40
=100-8KC1	1	Motorschuetz 15kW/400V	Siemens	M10013766	=100/32.2	3RT10 34-3BB40
=100-9KC1	1	Motorschuetz, 4kW/400V	Siemens	M10014900	=100/32.3	3RT10 16-2BB41
=100-10KC1	1	Motorschuetz 3kW/400V AC	Siemens	M10013763	=100/32.4	3RT10 15-2BB41
=100-00K2	1	Stecksocket mit Relais	Wago GmbH & Co. KG	M10019133 + M10019138	=100/32.7	788-312
=100-00K3	1	Stecksocket mit Relais	Wago GmbH & Co. KG	M10019133 + M10019138	=100/32.8	788-312
=100-8K2	1	Stecksocket mit Relais	Wago GmbH & Co. KG	M10019133 + M10019138	=100/33.2	788-312
=100-0H6	1	Leuchtmelder blau, mit glatter Linse	Siemens	M10015571 + M10019226	=100/33.8	3SB32 44-6AA50
=100-0H6	1	Schildtraeger	Siemens	3SB39 25-0AV	=100/33.8	3SB39 25-0AV
=100-0H2	1	Leuchtmelder weiß, Linse mit konz. Ringen	Siemens	3SB32 44-6BA60-0CC0	=100/34.2	3SB32 44-6BA60-0CC0
=100-0H2	1	Schildtraeger	Siemens	3SB39 25-0AV	=100/34.2	3SB39 25-0AV
=100-0H2.1	1	Leuchtmelder weiß, Linse mit konz. Ringen	Siemens	3SB32 44-6BA60-0CC0	=100/34.3	3SB32 44-6BA60-0CC0
=100-0H2.1	1	Schildtraeger	Siemens	3SB39 25-0AV	=100/34.3	3SB39 25-0AV
=100-LS1	1	Socket fuer Relais LZX:MT32...	Siemens	M10010285	=100/36.1	LZX:MT78750
=100-LS1	1	Knebel 2 Schalterstellungen,	Siemens	M10021302	=100/36.1	3SB32 02-2KA11-0CC0
=100-LS1	1	Schutzkappe	Siemens	3SB39 21-0BA	=100/36.1	3SB39 21-0BA
=100-LS1	1	Schildtraeger	Siemens	3SB39 25-0AV	=100/36.1	3SB39 25-0AV
=100-GF1	1	2-Leiter-Sicherungsklemme, grau	Wago GmbH & Co. KG	M10015067	=100/37.0	282-696
=100-GF1	1	Abschluss- und Zwischenplatte, orange	Wago GmbH & Co. KG	M10015068	=100/37.0	282-333
=100-GA1	1	Schluesselschaltgeraet	AVS Aggregatebau	M10011598	=100/37.1	K26MUE_KSE_72
=100-GK1	1	Stecksocket mit Relais	Wago GmbH & Co. KG	M10019133 + M10019138	=100/37.1	788-312
=100-GK6	1	Stecksocket mit Relais	Wago GmbH & Co. KG	M10019133 + M10019138	=100/37.2	788-312
=100-GK61	1	Stecksocket mit Relais	Wago GmbH & Co. KG	M10019133 + M10019138	=100/37.6	788-312
=100-GK9	1	Stecksocket mit Relais	Wago GmbH & Co. KG	M10019133 + M10019138	=100/37.7	788-312
=100-GK9.1	1	Stecksocket mit Relais	Wago GmbH & Co. KG	M10019133 + M10019138	=100/37.8	788-312

4

6

DATE	18.Apr.2012	KLEEMANN GMBH		 	STUECKLISTE	KLEEMANN SERIES	K007	= STK	+
EDITED	JHE	MOBICAT MC 120 Z US				KLEEMANN MATERIAL NO	M20000111_01	CAE-SYSTEM: EPLAN 5.70	PG.
CONTR.	D. MALLKOWSKY	ORIGIN	REP.F.	REP.T.				PG.	12
MODIFICAT.	DATE	NAME	NORM	DIN					

# Part's list

TPLSTK02 02.04.2003

Component designation	Amount	DESIGNATION	Manufacturer	Article number	Page/Path	Model number
=100-P5	1	Betriebsstundenzaehler 12 - 48V DC	ABB AG	M10011841	=100/38.1	E233-12/48
=100-GP1	1	Tankanzeige elektrisch, rund D=64mm	Motometer	M10019161	=100/38.2	609 060 1039
=100-GK26	1	Stecksockel mit Relais	Wago GmbH & Co. KG	M10019133 + M10019138	=100/38.4	788-312
=100-GKT1	1	Zeitrelais mit LED	Siemens	M10014285	=100/38.5	3RP15 25-2AP30
=100-GKT2	1	Zeitrelais mit LED	Siemens	M10014285	=100/38.8	3RP15 25-2AP30
=100-GS2	1	Drucktaster schwarz	Siemens	2213477	=100/39.6	3SB32 02-0AA11-0CC0
=100-GS2	1	Schildtraeger	Siemens	3SB39 25-0AV	=100/39.6	3SB39 25-0AV
=100-GH1	1	Leuchtmelder gelb, mit glatter Linse	Siemens	3SB32 44-6AA30-0CC0	=100/39.7	3SB32 44-6AA30-0CC0
=100-GH1	1	Schildtraeger	Siemens	3SB39 25-0AV	=100/39.7	3SB39 25-0AV
=100-GH2	1	Leuchtmelder gelb, mit glatter Linse	Siemens	3SB32 44-6AA30-0CC0	=100/39.7	3SB32 44-6AA30-0CC0
=100-GH2	1	Schildtraeger	Siemens	3SB39 25-0AV	=100/39.7	3SB39 25-0AV
=100-GH3	1	Leuchtmelder rot, mit glatter Linse	Siemens	3SB32 44-6AA20-0CC0	=100/39.8	3SB32 44-6AA20-0CC0
=100-GH3	1	Schildtraeger	Siemens	3SB39 25-0AV	=100/39.8	3SB39 25-0AV
=100-SN0	1	Knebel 2 Schalterstellungen,	Siemens	M10021302	=100/41.1	3SB32 02-2KA11-0CC0
=100-SN0	2	Schaltelement 1OE	Siemens	M10017539	=100/41.1	3SB34 03-0C
=100-SN0	1	Schutzkappe	Siemens	3SB39 21-0BA	=100/41.1	3SB39 21-0BA
=100-SN0	1	Schildtraeger	Siemens	3SB39 25-0AV	=100/41.1	3SB39 25-0AV
=100-KGA1	1	Hilfsschuetz SIRIUS	Siemens	M10014272	=100/41.2	3RH11 22-2BB40
=100-KGA2	1	Stecksockel mit Relais	Wago GmbH & Co. KG	M10019133 + M10019138	=100/41.2	788-312
=100-KGA3	1	Stecksockel mit Relais	Wago GmbH & Co. KG	M10019133 + M10019138	=100/41.3	788-312
=100-8K04	1	Stecksockel mit Relais	Wago GmbH & Co. KG	M10019133 + M10019138	=100/41.4	788-312
=100-8K03	1	Stecksockel mit Relais	Wago GmbH & Co. KG	M10019133 + M10019138	=100/41.4	788-312

DATE	18.Apr.2012	KLEEMANN GMBH		 	STUECKLISTE	KLEEMANN SERIES	K007	= STK	+
EDITED	JHE	MOBICAT MC 120 Z US				KLEEMANN MATERIAL NO	M20000111_01	CAE-SYSTEM: EPLAN 5.70	PG. 6
CONTR.	D. MALLKOWSKY	ORIGIN	REP.F.	REP.T.				PG. 12	
MODIFICAT.	DATE	NAME	NORM	DIN					

# Part's list

TPLSTK02 02.04.2003

Component designation	Amount	DESIGNATION	Manufacturer	Article number	Page/Path	Model number
-XOUT	1	Attachment housing 16-pol. with 2 bow	ILME GmbH	M10020941	=A0/19.6	CHI 16
-XOUT	1	Plug housing 16-pol. with bolt,side cable outlet	ILME GmbH	M10011806	=A0/19.6	CHO 16
-XOUT	1	Socket insert 16-poled+pe 16A max, 400V	ILME GmbH	M10011811	=A0/19.6	CNF 16
-XOUT	1	Pin insert 16-pol+pe 16A max, 400V	ILME GmbH	M10011812	=A0/19.6	CNM 16
-3X2	1	Plug housing 4-pol.+pe with bow and screwing, metal	ILME GmbH	M10011803	=A0/19.6	CKA 03 VGS
-3X2	1	Pin insert 4-pol+pe 10A max, 250V	ILME GmbH	M10011804	=A0/19.6	CKM 04
-3X2	1	Socket insert 4-pol+pe 10A max, 250V	ILME GmbH	M10011805	=A0/19.6	CKF 04
-4X1	1	Pin insert 4+2-pol +PE 80A max+16A max, 400V	ILME GmbH	CXM 4/2	=A0/19.6	CXM 4/2
-4X1	1	Socket insert 4+2-pol +PE 80A max+16A max, 400V	ILME GmbH	CXF 4/2	=A0/19.6	CXF 4/2
-4X1	1	Attachment housing 16-pol. with 2 bow	ILME GmbH	M10020941	=A0/19.6	CHI 16
-4X1	1	Plug housing M32 with Bolt for 2 Bow	ILME GmbH	MHO 16.32	=A0/19.6	MHO 16.32
-4X2	1	Pin insert 4-pol+pe 10A max, 250V	ILME GmbH	M10011804	=A0/19.6	CKM 04
-4X2	1	Socket insert 4-pol+pe 10A max, 250V	ILME GmbH	M10011805	=A0/19.6	CKF 04
-4X2	1	Add-on housing without Cable outlet	ILME GmbH	CKAX 03 IA	=A0/19.6	CKAX 03 IA
-4X2	1	Plug housing with Bolt	ILME GmbH	MKA V20	=A0/19.6	MKA V20
=100-0P1	1	Ammeter 0-800A	Yokogawa	251340LSSNUL	=100/1.1	251340LSSNUL
=100-0T02	1	Summation current transformer 500ma for FAULT CURRENT-Relay Type MFR	Doepke	MFIW 105/0,5	=100/1.1	MFIW 105/0,5
=100-0Q1	1	Power switch 3p 600A BG3 NZMN3-AE600-NA	Moeller	M00000003	=100/1.1	NZMN3-AE600-NA
=100-0Q1	1	Main switch kit f. NZM3, N3	Moeller	NZM3-XTVDVR-NA	=100/1.1	NZM3-XTVDVR-NA
=100-0Q1	1	Undervoltage circuit breaker with 2 vhi NZM2/3-XUHIVC380-440AC	Moeller	M10017491	=100/1.1	NZM2/3-XUHIVC380-440AC
=100-0Q1	1	Contact element 1S Front M22-CK10	Moeller	M10016214	=100/1.1	M22-CK10
=100-0T01	1	Current transformer 800/5A	IT INC	58RBT-801	=100/1.1	58RBT-801
=100-0F00	1	Fuse holder 2-pol. 600V, 30A	Woehner GmbH & Co. KG	31 296	=100/1.2	31 296
=100-0F00	2	Fuse link size 10 x 38 2A, 600V AC	Woehner GmbH & Co. KG	M10025367	=100/1.2	31 245
=100-PE	2	Busbar holder 1pol	Rittal GmbH & Co. KG	SV 9340.030	=100/1.2	SV 9340.030
=100-0F01	1	RESIDUAL CURRENT DEVICE 2NO, 500V, 16A	Doepke	M10016345	=100/1.3	MFR
=100-0SS	1	Key-operated switch, o-i ronis 1NO w.holder	Siemens	M10021350	=100/1.6	3SB32 02-4AD11-0CC0
=100-0SS	1	Tag holder	Siemens	3SB39 25-0AV	=100/1.6	3SB39 25-0AV
=100-TS1	1	Position switch 1NO+1NC	Siemens	3SE2 200-1C	=100/1.7	3SE2 200-1C
=100-TS2	1	Position switch 1NO+1NC	Siemens	3SE2 200-1C	=100/1.7	3SE2 200-1C
=100-TS3	1	Position switch 1NO+1NC	Siemens	3SE2 200-1C	=100/1.7	3SE2 200-1C
=100-TS4	1	Position switch 1NO+1NC	Siemens	3SE2 200-1C	=100/1.7	3SE2 200-1C
=100-0F06	1	Fuse holder 1-pol. 600V, 30A	Woehner GmbH & Co. KG	31 295	=100/3.1	31 295
=100-0F06	1	Fuse link size 10 x 38 6A, 600V AC	Woehner GmbH & Co. KG	M10025368	=100/3.1	31 247
=100-0F07	1	Fuse holder 1-pol. 600V, 30A	Woehner GmbH & Co. KG	31 295	=100/3.3	31 295
=100-0F07	1	Fuse link size 10 x 38 6A, 600V AC	Woehner GmbH & Co. KG	M10025368	=100/3.3	31 247
=100-0F08	1	Fuse holder 1-pol. 600V, 30A	Woehner GmbH & Co. KG	31 295	=100/3.5	31 295
=100-0F08	1	Fuse link size 10 x 38 10A, 600V AC	Woehner GmbH & Co. KG	M10025369	=100/3.5	31 248
=100-SX	1	Handle 2 switch positions, unlighted locked, switch angle 50°	Siemens	M10015574	=100/3.7	3SB30 00-2KA11
=100-SX	1	Protecting cap for Handle	Siemens	3SB39 21-0BA	=100/3.7	3SB39 21-0BA
=100-SX	1	Tag holder	Siemens	3SB39 25-0AV	=100/3.7	3SB39 25-0AV
=100-KX	1	Plug-in base w. relay 2 changeover contact 250V AC/8A coil 24V DC	Wago GmbH & Co. KG	M10019133 + M10019138	=100/3.7	788-312
=100-0F03	1	Fuse holder 3-pol. 600V, 30A	Woehner GmbH & Co. KG	31 297	=100/4.1	31 297
=100-0F03	3	Fuse link size 10 x 38 30A, 600V AC	Woehner GmbH & Co. KG	M10025373	=100/4.1	31 252
=100-0F04	1	RESIDUAL CURRENT DEVICE 4pol 40A	ABB AG	F204A-40/0,03	=100/4.1	F204A-40/0,03
=100-0X5	1	Installing shock-proof socket Type: 60380MZ 5-Pol 480V/30A	Mennekes	M10019713	=100/4.1	ME 530R7W
=100-0F0	1	Fuse holder AMBUS Easyswitch 3-pol. 690V, 125A	Woehner GmbH & Co. KG	31 123	=100/5.1	31 123
=100-0F0	3	Fuse link 22x58 100A, 690V, gg	Woehner GmbH & Co. KG	31 203	=100/5.1	31 203
=100-0F0	1	CB Component adaptor 125A,600V, UL 508	Rittal GmbH & Co. KG	2196726	=100/5.1	SV 9342.550
=100-0X1	1	Installing shock-proof socket Type: 60063MZ 4-Pol 480V/100A	Mennekes	M10019712	=100/5.1	ME 5100R7W

6

8

DATE	18.Apr.2012	KLEEMANN GMBH		 	PART'S LIST	KLEEMANN SERIES	K007	= STK	+
EDITED	JHE	MOBICAT MC 120 Z US				KLEEMANN MATERIAL NO	M20000111_01	CAE-SYSTEM: EPLAN 5.70	PG.
CONTR.	D. MALLKOWSKY	ORIGIN	REP.F.	REP.T.				PG.	12
MODIFICAT.	DATE	NAME	NORM	DIN					



# Part's list

TPLSTK02 02.04.2003

Component designation	Amount	DESIGNATION	Manufacturer	Article number	Page/Path	Model number
=100-0F05	1	Fuse holder 1-pol. 600V, 30A	Woehner GmbH & Co. KG	31 295	=100/5.3	31 295
=100-0F05	1	Fuse link size 10 x 38 15A, 600V AC	Woehner GmbH & Co. KG	M10025370	=100/5.3	31 249
=100-0FI05	1	RESIDUAL CURRENT DEVICE 2pol 25A	ABB AG	F202A-25/0,03	=100/5.3	F202A-25/0,03
=100-0X4	1	Socket 1-Pol+N+PE 125V/15A	ABL SURSUM	UL12505	=100/5.3	UL12505
=100-0F1	1	Fuse holder 2-pol. 600V, 30A	Woehner GmbH & Co. KG	31 296	=100/5.5	31 296
=100-0F1	2	Fuse link size 10 x 38 15A, 600V AC	Woehner GmbH & Co. KG	M10025370	=100/5.5	31 249
=100-0F1	1	OM Adaptor 32A,690V, UL 508	Rittal GmbH & Co. KG	M10025431	=100/5.5	SV 9340.510
=100-0T1	1	Transformer 1-phase 1600VA Prim. 400V AC Sec. 2x115V AC	Block GmbH & Co.KG	STU1600/4/23	=100/5.5	STU1600/4/23
=100-0F1.3	1	Automatic circuit breaker one-pole type c 2A 400V AC/220V DC	Siemens	M10019972	=100/5.5	5SY6 102-7
=100-0F1.3	1	Auxiliary switch 1no 1nc for Is-switch d=70mm	Siemens	M10019130	=100/5.5	5ST3 010
=100-0F02	1	Automatic circuit breaker two-pole type c 2A 440V AC/60V DC	Siemens	M10019162	=100/5.7	5SY6 202-7
=100-0P2	1	Voltmeter 500v	Yokogawa	251344SFSFUL	=100/5.7	251344SFSFUL
=100-0S00	1	Mushroom push button red 1NC,locking,rotative unlatching	Siemens	M10015479	=100/6.6	3SB32 03-1HA20-0CC0
=100-0S00	2	Switching element w.1 switch member 1no	Siemens	M10017540	=100/6.6	3SB34 03-0B
=100-0S00	1	Protecting cap for Pilz-Push button	Siemens	3SB19 02-2BH	=100/6.6	3SB19 02-2BH
=100-0S00	1	Tag holder for EMERGENCY-OFF Pilz-Push button	Moeller	M22-XAK1	=100/6.6	M22-XAK1
=100-D1	1	Switchgear, 230V 3NO+1NC	Pilz GmbH & Co.	M10015064	=100/6.8	PNOZ X4
=100-0F2	1	Fuse holder 1-pol. 600V, 30A	Woehner GmbH & Co. KG	31 295	=100/7.1	31 295
=100-0F2	1	Fuse link size 10 x 38 10A, 600V AC	Woehner GmbH & Co. KG	M10025369	=100/7.1	31 248
=100-K0.1	1	Auxiliary relay sirius 4NO 24VDC Cage Clamp-Connection,w.out Varistor	Siemens	M10018964	=100/7.1	3RH11 40-2BB40
=100-0F3	1	Automatic circuit breaker one-pole type c 6A 400V AC/220V DC	Siemens	M10019164	=100/7.3	5SY6 106-7
=100-0F3	1	Auxiliary switch 1no 1nc for Is-switch d=70mm	Siemens	M10019130	=100/7.3	5ST3 010
=100-0S1	1	Key-operated switch, o-i ronis 1NO w.holder	Siemens	M10021350	=100/7.3	3SB32 02-4AD11-0CC0
=100-0S1	1	Tag holder	Siemens	3SB39 25-0AV	=100/7.3	3SB39 25-0AV
=100-0K1	1	Motor contactor, 4kw/400v 3MC 1NO 24V DC w.out Varistor,Cage-Clamp	Siemens	M10014900	=100/7.3	3RT10 16-2BB41
=100-0K1	1	Auxiliary switch block 2NO+2NC Cage-Clamp-Connection	Siemens	M10019973	=100/7.3	3RH19 11-2FA22
=100-GF2	1	Fuse holder 1-pol. 600V, 30A	Woehner GmbH & Co. KG	31 295	=100/7.5	31 295
=100-GF2	1	Fuse link size 10 x 38 15A, 600V AC	Woehner GmbH & Co. KG	M10025370	=100/7.5	31 249
=100+M-1H2	1	Reverse drive warner 24V DC	Bosch	A65	=100/7.6	A65
=100-0F4	1	Fuse holder 1-pol. 600V, 30A	Woehner GmbH & Co. KG	31 295	=100/7.6	31 295
=100-0F4	1	Fuse link size 10 x 38 6A, 600V AC	Woehner GmbH & Co. KG	M10025368	=100/7.6	31 247
=100+M-00H2	1	Siren 24v dc, 0,5a	Funke+Huster GmbH	M10011815	=100/7.7	KS 24
=100+M-00H3	1	Flash light	Telemecanique	M10011814	=100/7.8	XVA L 6B5 C024
=100-1P1	1	Ammeter 400/800/5a	Langer	RQ 72 E 400/800/5A	=100/8.1	RQ 72 E 400/800/5A
=100-1K01	1	Monitoring relay 1 changeover cont.,24-240V AC/DC,0,1-10A AC/DC	Siemens	M10014275	=100/8.1	3UG46 22-2AW30
=100-1T1	1	Current transformer ac 32 400/5A	Langer	TAC 32 400/5A	=100/8.3	TAC 32 400/5A
=100-1K0	1	Electronic motor protection relay 2NO 2NC	Klöckner Moeller	M10013726	=100/8.6	ZEV
=100-1K0	1	Current sensor 40-820a	Klöckner Moeller	M10019256	=100/8.6	ZEV-XSW-820
=100-1K0	1	Connecting line f.zev-xsw-25, 65, 145, 820 Length 800mm	Moeller	M10019257	=100/8.6	ZEV-XVK-80
=100-1KC1	1	Motor contactor, 90kw/400v 3H, 2S+2NC, 110-127V AC/DC, with Varistor	Siemens	M10020791	=100/9.1	3RT10 56-2AF36
=100-1KT1	1	Time-delay relay 24V DC/AC,100...127V AC 1NO+1NO delayed, Cage Clamp	Siemens	3RP15 76-2NQ30	=100/9.3	3RP15 76-2NQ30
=100-1KC2	1	Motor contactor, 90kw/400v 3H, 2S+2NC, 110-127V AC/DC, with Varistor	Siemens	M10020791	=100/9.4	3RT10 56-2AF36
=100-1KC3	1	Motor contactor, 75kw/400v 3H, 2S+2NC, 110-127V AC/DC, with Varistor	Siemens	M10020792	=100/9.6	3RT10 55-2AF36
=100-2Q1	1	Circuit breaker 4,5-6,3a with auxiliary switch 1no+1nc	Siemens	M10013566	=100/10.1	3RV10 11-1GA15
=100-2Q1	1	OM Adaptor 25A,690V, UL 508	Rittal GmbH & Co. KG	2196964	=100/10.1	SV 9340.310
=100-2Q1	1	Mounting rail 45mm	Rittal GmbH & Co. KG	2196728	=100/10.1	SV 9342.850
=100-2F1	1	Automatic circuit breaker three-pole type c 25A 440V AC/60V DC	Siemens	M10019129	=100/10.4	5SY6 325-7
=100-2F1	1	Auxiliary switch 1no 1nc for Is-switch d=70mm	Siemens	M10019130	=100/10.4	5ST3 010
=100-2F1	1	OM Adaptor 32A,690V	Rittal GmbH & Co. KG	2196715	=100/10.4	SV 9340.460
=100-3Q1	1	Circuit breaker 11-16a with auxiliary switch	Siemens	M10013570	=100/10.7	3RV10 21-4AA15

7

9

DATE	18.Apr.2012	KLEEMANN GMBH		 	PART'S LIST	KLEEMANN SERIES	K007	= STK	+
EDITED	JHE	MOBICAT MC 120 Z US				KLEEMANN MATERIAL NO	M20000111_01	CAE-SYSTEM: EPLAN 5.70	PG.
CONTR.	D. MALLKOWSKY	ORIGIN	REP.F.	REP.T.				PG.	8
MODIFICAT.	DATE	NAME	NORM	DIN				PG.	12

# Part's list

TPLSTK02 02.04.2003

Component designation	Amount	DESIGNATION	Manufacturer	Article number	Page/Path	Model number
=100-3Q1	1	OM Adaptor 25A,690V, UL 508	Rittal GmbH & Co. KG	2196964	=100/10.7	SV 9340.310
=100-3Q1	1	Mounting rail 45mm	Rittal GmbH & Co. KG	2196728	=100/10.7	SV 9342.850
=100-3X1	1	Installing shock-proof socket Type: 60336MZ 5-Pol 480V/20A	Mennekes	ME 520R7W	=100/10.7	ME 520R7W
=100-4Q1	1	Circuit breaker 22-32a w.out auxiliary switch,f.motor protection	Siemens	M10018521	=100/11.1	3RV10 31-4EA10
=100-4Q1	1	OM Adaptor 65A,690V, UL 508	Rittal GmbH & Co. KG	SV 9340.430	=100/11.1	SV 9340.430
=100-4Q1	1	Mounting rail 45mm	Rittal GmbH & Co. KG	2196728	=100/11.1	SV 9342.850
=100-4K0	1	Electronic motor protection relay 2NO 2NC	Klöckner Moeller	M10013726	=100/11.3	ZEV
=100-4K0	1	Current sensor 2-65a	Klöckner Moeller	M10013727	=100/11.3	ZEV-XSW-65
=100-4K0	1	Connecting line f.zev-xsw-25, 65, 145, 820 Length 200mm	Moeller	M10013728	=100/11.3	ZEV-XVK-20
=100-5Q1	1	Circuit breaker 7-10a with auxiliary switch	Siemens	M10013568	=100/11.4	3RV10 11-1JA15
=100-5Q1	1	OM Adaptor 25A,690V, UL 508	Rittal GmbH & Co. KG	2196964	=100/11.4	SV 9340.310
=100-5Q1	1	Mounting rail 45mm	Rittal GmbH & Co. KG	2196728	=100/11.4	SV 9342.850
=100-5K0	1	Electronic motor protection relay 2NO 2NC	Klöckner Moeller	M10013726	=100/11.5	ZEV
=100-5K0	1	Current sensor 1-25a	Klöckner Moeller	M10019255	=100/11.5	ZEV-XSW-25
=100-5K0	1	Connecting line f.zev-xsw-25, 65, 145, 820 Length 200mm	Moeller	M10013728	=100/11.5	ZEV-XVK-20
=100-5Q2	1	Circuit breaker 7-10a with auxiliary switch	Siemens	M10013568	=100/11.7	3RV10 11-1JA15
=100-5Q2	1	OM Adaptor 25A,690V, UL 508	Rittal GmbH & Co. KG	2196964	=100/11.7	SV 9340.310
=100-5Q2	1	Mounting rail 45mm	Rittal GmbH & Co. KG	2196728	=100/11.7	SV 9342.850
=100-5K0.1	1	Electronic motor protection relay 2NO 2NC	Klöckner Moeller	M10013726	=100/11.8	ZEV
=100-5K0.1	1	Current sensor 1-25a	Klöckner Moeller	M10019255	=100/11.8	ZEV-XSW-25
=100-5K0.1	1	Connecting line f.zev-xsw-25, 65, 145, 820 Length 200mm	Moeller	M10013728	=100/11.8	ZEV-XVK-20
=100-6Q1	1	Circuit breaker 11-16a with auxiliary switch	Siemens	M10013570	=100/12.1	3RV10 21-4AA15
=100-6Q1	1	OM Adaptor 25A,690V, UL 508	Rittal GmbH & Co. KG	2196964	=100/12.1	SV 9340.310
=100-6Q1	1	Mounting rail 45mm	Rittal GmbH & Co. KG	2196728	=100/12.1	SV 9342.850
=100-7F1	1	Automatic circuit breaker three-pole type c 63A 440V AC/60V DC	Siemens	M10019124	=100/12.4	5SY6 363-7
=100-7F1	1	Auxiliary switch 1no 1nc for ls-switch d=70mm	Siemens	M10019130	=100/12.4	5ST3 010
=100-7F1	1	OM Adaptor 65A, 690V	Rittal GmbH & Co. KG	SV 9340.410	=100/12.4	SV 9340.410
=100-7K0	1	Electronic motor protection relay 2NO 2NC	Klöckner Moeller	M10013726	=100/12.5	ZEV
=100-7K0	1	Current sensor 2-65a	Klöckner Moeller	M10013727	=100/12.5	ZEV-XSW-65
=100-7K0	1	Connecting line f.zev-xsw-25, 65, 145, 820 Length 200mm	Moeller	M10013728	=100/12.5	ZEV-XVK-20
=100-9Q1	1	Circuit breaker 7-10a with auxiliary switch	Siemens	M10013568	=100/13.1	3RV10 11-1JA15
=100-9Q1	1	OM Adaptor 25A,690V, UL 508	Rittal GmbH & Co. KG	2196964	=100/13.1	SV 9340.310
=100-9Q1	1	Mounting rail 45mm	Rittal GmbH & Co. KG	2196728	=100/13.1	SV 9342.850
=100-10Q1	1	Circuit breaker 4,5-6,3a with auxiliary switch 1no+1nc	Siemens	M10013566	=100/13.3	3RV10 11-1GA15
=100-10Q1	1	OM Adaptor 32A,690V, UL 508	Rittal GmbH & Co. KG	M10025431	=100/13.3	SV 9340.510
=100-10Q1	1	Mounting rail 45mm	Rittal GmbH & Co. KG	2196728	=100/13.3	SV 9342.850
=100-13Q1	1	Circuit breaker 0,22-0,32a with auxiliary switch	Siemens	M10015340	=100/13.6	3RV10 11-0DA15
=100-13Q1	1	OM Adaptor 25A,690V, UL 508	Rittal GmbH & Co. KG	2196964	=100/13.6	SV 9340.310
=100-8Q1	1	Control switch 4-pol 12kw 400V 32A	Moeller	M10013874	=100/14.1	T3-4-8223/E
=100-8A1	1	Frequency converter 380-480V, 25/29A, 50-60Hz, 11/15kw	Control Techniques	M20000268	=100/14.2	SK 2403
=100-8F1	1	Automatic circuit breaker three-pole type c 32A 440V AC/60V DC	Siemens	M10019128	=100/14.2	5SY6 332-7
=100-8F1	1	Auxiliary switch 1no 1nc for ls-switch d=70mm	Siemens	M10019130	=100/14.2	5ST3 010
=100-8F1	1	OM Adaptor 32A,690V	Rittal GmbH & Co. KG	2196715	=100/14.2	SV 9340.460
=100-8L1	1	Power choke 28,8A, max.600V 50-60Hz	Control Techniques	KDD 0,4/N/600V/28,8A/4UK	=100/14.2	KDD 0,4/N/600V/28,8A/4UK
=100-8F2	1	Overload relay 7-10a, 1no+1nc f.individual assembly	Siemens	M10014903	=100/14.2	3RU1116-1JC1
=100-8F3	1	Overload relay 7-10a, 1no+1nc f.individual assembly	Siemens	M10014903	=100/14.4	3RU1116-1JC1
=100-RB	1	Frame resistance SP 100W 400V 37,5 Ohm	Control Techniques	M10020877	=100/14.7	SP
=100-8K0	1	Thermal machine protection, 2 led 1NO+1NC, 24V DC, Cage Clamp-Connection	Siemens	M10014273	=100/15.3	3RN10 10-2CB00
=100-SC	1	Handle 2 switch positions, locking, black, 1no	Siemens	M10021302	=100/17.1	3SB32 02-2KA11-0CC0
=100-SC	1	Protecting cap for Handle	Siemens	3SB39 21-0BA	=100/17.1	3SB39 21-0BA

8

10

DATE	18.Apr.2012	KLEEMANN GMBH		 	PART'S LIST	KLEEMANN SERIES	K007	= STK	+
EDITED	JHE	MOBICAT MC 120 Z US				KLEEMANN MATERIAL NO	M20000111_01	CAE-SYSTEM: EPLAN 5.70	PG.
CONTR.	D. MALLKOWSKY	ORIGIN	REP.F.	REP.T.				PG.	12
MODIFICAT.	DATE	NAME	NORM	DIN					

# Part's list

TPLSTK02 02.04.2003

Component designation	Amount	DESIGNATION	Manufacturer	Article number	Page/Path	Model number
=100-SC	1	Tag holder	Siemens	3SB39 25-0AV	=100/17.1	3SB39 25-0AV
=100-AO_OP	1	Operator panel 256kB user memory, 24V DC	VIPA GmbH	M10019119	=100/17.2	OP 03 603-1OP00
=100-A_FW	1	Remote maintenance system	MB Connect Line	M20000333	=100/17.2	MDH 513
=100-A_FW	1	Connecting cable	MB Connect Line	8248	=100/17.2	8248
=100-A_FW	1	MPI Connecting cable 1,2m	MB Connect Line	KS 1.2/9	=100/17.2	KS 1.2/9
=100-AO_CPU	1	PLC-CPU WITH MPI 256 counter, 48kByte RAM	VIPA GmbH	M10020750	=100/17.2	VIPA 214-1BA02
=100-AO_CPU	1	Bus connector 4-fold	VIPA GmbH	290-0AA40	=100/17.2	290-0AA40
=100-AO_CPU	1	Bus connector 8-fold	VIPA GmbH	290-0AA80	=100/17.2	290-0AA80
=100-AO_2	1	In-/output module sm 238 12DI+4DIO,3AI+1Pt100,2AO,24V DC	VIPA GmbH	M10020887	=100/17.2	SM 238-2BC00
=100-AO_3	1	Digital output module sm 222 16DO, 24V DC, 1A	VIPA GmbH	M10021058	=100/17.3	SM 222-1BH10
=100-AO_4	1	Digital input module sm 221 32DI, 24VDC	VIPA GmbH	M10021059	=100/17.4	SM 221-2BL10
=100-AO_5	1	Digital input module sm 221 32DI, 24VDC	VIPA GmbH	M10021059	=100/17.5	SM 221-2BL10
=100-AO_6	1	Digital input module sm 221 32DI, 24VDC	VIPA GmbH	M10021059	=100/17.6	SM 221-2BL10
=100-1K1	1	Plug-in base w. relay 2 changeover contact 250V AC/8A coil 24V DC	Wago GmbH & Co. KG	M10019133 + M10019138	=100/22.1	788-312
=100-1K08	1	Motor contactor 3kw/400v ac 3MC 1NO 24V DC, w.out Varistor,Cage-Clamp	Siemens	M10013763	=100/22.5	3RT10 15-2BB41
=100-2KC1	1	Motor contactor 3kw/400v ac 3MC 1NO 24V DC, w.out Varistor,Cage-Clamp	Siemens	M10013763	=100/23.1	3RT10 15-2BB41
=100-2KC2	1	Motor contactor 3kw/400v ac 3MC 1NO 24V DC, w.out Varistor,Cage-Clamp	Siemens	M10013763	=100/23.2	3RT10 15-2BB41
=100-3KC1	1	Motor contactor, 5,5kw/400v 3MC 1NO 24V DC, w.out Varistor,Cage-Clamp	Siemens	M10014901	=100/23.3	3RT10 17-2BB41
=100-2KC3	1	Motor contactor 11kw/400v 3MC 24V DC ,w.out Varistor, Cage Clamp at Coil	Siemens	M10013765	=100/23.4	3RT10 26-3BB40
=100-4KC1	1	Motor contactor 15kw/400v 3MC 24V DC ,w.out Varistor, Cage Clamp at Coil	Siemens	M10013766	=100/23.5	3RT10 34-3BB40
=100-5KC1	1	Motor contactor, 4kw/400v 3MC 1NO 24V DC w.out Varistor,Cage-Clamp	Siemens	M10014900	=100/23.6	3RT10 16-2BB41
=100-5KC2	1	Motor contactor, 4kw/400v 3MC 1NO 24V DC w.out Varistor,Cage-Clamp	Siemens	M10014900	=100/23.7	3RT10 16-2BB41
=100-6KC1	1	Motor contactor, 5,5kw/400v 3MC 1NO 24V DC, w.out Varistor,Cage-Clamp	Siemens	M10014901	=100/23.8	3RT10 17-2BB41
=100-S0.0	1	Illuminated push button white, led integrated flat push button 1no, uc 24v	Siemens	2219470	=100/24.1	3SB32 45-0AA61-0CC0
=100-S0.0	1	Protecting cap for Push button flat	Siemens	3SB39 21-0AH	=100/24.1	3SB39 21-0AH
=100-S0.0	1	Tag holder	Siemens	3SB39 25-0AV	=100/24.1	3SB39 25-0AV
=100-S0.1	1	Push button red flat push button 1nc	Siemens	2219480	=100/24.2	3SB32 03-0AA21-0CC0
=100-S0.1	1	Protecting cap for Push button flat	Siemens	3SB39 21-0AH	=100/24.2	3SB39 21-0AH
=100-S0.1	1	Tag holder	Siemens	3SB39 25-0AV	=100/24.2	3SB39 25-0AV
=100-S0.2	1	Handle 2 switch positions, locking, black, 1no	Siemens	M10021302	=100/24.3	3SB32 02-2KA11-0CC0
=100-S0.2	1	Protecting cap for Handle	Siemens	3SB39 21-0BA	=100/24.3	3SB39 21-0BA
=100-S0.2	1	Tag holder	Siemens	3SB39 25-0AV	=100/24.3	3SB39 25-0AV
=100-S0.3	1	Push button blue flat push button, 1no	Siemens	3SB32 02-0AA51-0CC0	=100/24.4	3SB32 02-0AA51-0CC0
=100-S0.3	1	Protecting cap for Push button flat	Siemens	3SB39 21-0AH	=100/24.4	3SB39 21-0AH
=100-S0.3	1	Tag holder	Siemens	3SB39 25-0AV	=100/24.4	3SB39 25-0AV
=100-S0.4	1	Illuminated push button red, led integrated flat push button 1nc, uc 24v	Siemens	2219472	=100/24.5	3SB32 46-0AA21-0CC0
=100-S0.4	2	Switching element w.1 switch member 1no	Siemens	M10017540	=100/24.5	3SB34 03-0B
=100-S0.4	1	Protecting cap for Push button flat	Siemens	3SB39 21-0AH	=100/24.5	3SB39 21-0AH
=100-S0.4	1	Tag holder	Siemens	3SB39 25-0AV	=100/24.5	3SB39 25-0AV
=100-2S2	1	Handle 3 switch positions, black, 1S+1Ö, 1S+1Ö	Siemens	3SB36 08-2DA11	=100/24.6	3SB36 08-2DA11
=100-2S2	1	Protecting cap for Handle	Siemens	3SB39 21-0BA	=100/24.6	3SB39 21-0BA
=100-2S2	1	Tag holder	Siemens	3SB39 25-0AV	=100/24.6	3SB39 25-0AV
=100-2S1	1	Illuminated push button green, led integrated flat push button 1no, uc 24v	Siemens	M10020706	=100/24.7	3SB32 45-0AA41-0CC0
=100-2S1	1	Protecting cap for Push button flat	Siemens	3SB39 21-0AH	=100/24.7	3SB39 21-0AH
=100-2S1	1	Tag holder	Siemens	3SB39 25-0AV	=100/24.7	3SB39 25-0AV
=100-3S1	1	Illuminated push button green, led integrated flat push button 1no, uc 24v	Siemens	M10020706	=100/24.8	3SB32 45-0AA41-0CC0
=100-3S1	1	Protecting cap for Push button flat	Siemens	3SB39 21-0AH	=100/24.8	3SB39 21-0AH
=100-3S1	1	Tag holder	Siemens	3SB39 25-0AV	=100/24.8	3SB39 25-0AV
=100-4S1	1	Illuminated push button green, led integrated flat push button 1no, uc 24v	Siemens	M10020706	=100/25.1	3SB32 45-0AA41-0CC0
=100-4S1	1	Protecting cap for Push button flat	Siemens	3SB39 21-0AH	=100/25.1	3SB39 21-0AH

11

9

DATE	18.Apr.2012	KLEEMANN GMBH		 	PART'S LIST	KLEEMANN SERIES	K007	= STK	+
EDITED	JHE	MOBICAT MC 120 Z US				KLEEMANN MATERIAL NO	M20000111_01	CAE-SYSTEM: EPLAN 5.70	PG.
CONTR.	D. MALLKOWSKY	ORIGIN	REP.F.	REP.T.				PG.	12
MODIFICAT.	DATE	NAME	NORM	DIN					

# Part's list

TPLSTK02 02.04.2003

Component designation	Amount	DESIGNATION	Manufacturer	Article number	Page/Path	Model number
=100-4S1	1	Tag holder	Siemens	3SB39 25-0AV	=100/25.1	3SB39 25-0AV
=100-5S1	1	Illuminated push button green, led integrated	Siemens	M10020706	=100/25.2	3SB32 45-0AA41-0CC0
=100-5S1	1	Protecting cap	Siemens	3SB39 21-0AH	=100/25.2	3SB39 21-0AH
=100-5S1	1	Tag holder	Siemens	3SB39 25-0AV	=100/25.2	3SB39 25-0AV
=100-6S1	1	Illuminated push button green, led integrated	Siemens	M10020706	=100/25.3	3SB32 45-0AA41-0CC0
=100-6S1	1	Protecting cap	Siemens	3SB39 21-0AH	=100/25.3	3SB39 21-0AH
=100-6S1	1	Tag holder	Siemens	3SB39 25-0AV	=100/25.3	3SB39 25-0AV
=100-7S1	1	Illuminated push button green, led integrated	Siemens	M10020706	=100/25.4	3SB32 45-0AA41-0CC0
=100-7S1	1	Protecting cap	Siemens	3SB39 21-0AH	=100/25.4	3SB39 21-0AH
=100-7S1	1	Tag holder	Siemens	3SB39 25-0AV	=100/25.4	3SB39 25-0AV
=100-8S1	1	Illuminated push button green, led integrated	Siemens	M10020706	=100/25.5	3SB32 45-0AA41-0CC0
=100-8S1	1	Protecting cap	Siemens	3SB39 21-0AH	=100/25.5	3SB39 21-0AH
=100-8S1	1	Tag holder	Siemens	3SB39 25-0AV	=100/25.5	3SB39 25-0AV
=100-10S1	1	Illuminated push button green, led integrated	Siemens	M10020706	=100/25.7	3SB32 45-0AA41-0CC0
=100-10S1	1	Protecting cap	Siemens	3SB39 21-0AH	=100/25.7	3SB39 21-0AH
=100-10S1	1	Tag holder	Siemens	3SB39 25-0AV	=100/25.7	3SB39 25-0AV
=100-9S1	1	Illuminated push button green, led integrated	Siemens	M10020706	=100/26.4	3SB32 45-0AA41-0CC0
=100-9S1	1	Protecting cap	Siemens	3SB39 21-0AH	=100/26.4	3SB39 21-0AH
=100-9S1	1	Tag holder	Siemens	3SB39 25-0AV	=100/26.4	3SB39 25-0AV
=100-S5.2	1	Illuminated push button yellow,led integrated	Siemens	3SB32 45-0AA31-0CC0	=100/29.3	3SB32 45-0AA31-0CC0
=100-S5.2	1	Protecting cap	Siemens	3SB39 21-0AH	=100/29.3	3SB39 21-0AH
=100-S5.2	1	Tag holder	Siemens	3SB39 25-0AV	=100/29.3	3SB39 25-0AV
=100+8S	1	Handle 3 switch positions,	Siemens	M10021301	=100/29.7	3SB32 10-2EA11-0CC0
=100+8S	1	Protecting cap	Siemens	3SB39 21-0BA	=100/29.7	3SB39 21-0BA
=100+8S	1	Tag holder	Siemens	3SB39 25-0AV	=100/29.7	3SB39 25-0AV
=100-7KC1	1	Motor contactor 15kw/400v	Siemens	M10013766	=100/32.1	3RT10 34-3BB40
=100-8KC1	1	Motor contactor 15kw/400v	Siemens	M10013766	=100/32.2	3RT10 34-3BB40
=100-9KC1	1	Motor contactor, 4kw/400v	Siemens	M10014900	=100/32.3	3RT10 16-2BB41
=100-10KC1	1	Motor contactor 3kw/400v ac	Siemens	M10013763	=100/32.4	3RT10 15-2BB41
=100-00K2	1	Plug-in base w. relay	Wago GmbH & Co. KG	M10019133 + M10019138	=100/32.7	788-312
=100-00K3	1	Plug-in base w. relay	Wago GmbH & Co. KG	M10019133 + M10019138	=100/32.8	788-312
=100-8K2	1	Plug-in base w. relay	Wago GmbH & Co. KG	M10019133 + M10019138	=100/33.2	788-312
=100-0H6	1	Signal lamp blue, with smooth lens	Siemens	M10015571 + M10019226	=100/33.8	3SB32 44-6AA50
=100-0H6	1	Tag holder	Siemens	3SB39 25-0AV	=100/33.8	3SB39 25-0AV
=100-0H2	1	Signal lamp white,Lens with conc. Rings	Siemens	3SB32 44-6BA60-0CC0	=100/34.2	3SB32 44-6BA60-0CC0
=100-0H2	1	Tag holder	Siemens	3SB39 25-0AV	=100/34.2	3SB39 25-0AV
=100-0H2.1	1	Signal lamp white,Lens with conc. Rings	Siemens	3SB32 44-6BA60-0CC0	=100/34.3	3SB32 44-6BA60-0CC0
=100-0H2.1	1	Tag holder	Siemens	3SB39 25-0AV	=100/34.3	3SB39 25-0AV
=100-LS1	1	Base for relay lx:mt32...	Siemens	M10010285	=100/36.1	LZX:MT78750
=100-LS1	1	Handle 2 switch positions,	Siemens	M10021302	=100/36.1	3SB32 02-2KA11-0CC0
=100-LS1	1	Protecting cap	Siemens	3SB39 21-0BA	=100/36.1	3SB39 21-0BA
=100-LS1	1	Tag holder	Siemens	3SB39 25-0AV	=100/36.1	3SB39 25-0AV
=100-GF1	1	2-lead-fuse clip, gray	Wago GmbH & Co. KG	M10015067	=100/37.0	282-696
=100-GF1	1	Cover and distance plate, orange	Wago GmbH & Co. KG	M10015068	=100/37.0	282-333
=100-GA1	1	Key-operated device	AVS Aggregatebau	M10011598	=100/37.1	K26MUE_KSE_72
=100-GK1	1	Plug-in base w. relay	Wago GmbH & Co. KG	M10019133 + M10019138	=100/37.1	788-312
=100-GK6	1	Plug-in base w. relay	Wago GmbH & Co. KG	M10019133 + M10019138	=100/37.2	788-312
=100-GK61	1	Plug-in base w. relay	Wago GmbH & Co. KG	M10019133 + M10019138	=100/37.6	788-312
=100-GK9	1	Plug-in base w. relay	Wago GmbH & Co. KG	M10019133 + M10019138	=100/37.7	788-312
=100-GK9.1	1	Plug-in base w. relay	Wago GmbH & Co. KG	M10019133 + M10019138	=100/37.8	788-312

10

12

DATE	18.Apr.2012	KLEEMANN GMBH		 	PART'S LIST	KLEEMANN SERIES	K007	= STK	+
EDITED	JHE	MOBICAT MC 120 Z US				KLEEMANN MATERIAL NO	M20000111_01	CAE-SYSTEM: EPLAN 5.70	PG.
CONTR.	D. MALLKOWSKY	ORIGIN	REP.F.	REP.T.				PG.	12
MODIFICAT.	DATE	NAME	NORM	DIN					



# Part's list

TPLSTK02 02.04.2003

Component designation	Amount	DESIGNATION	Manufacturer	Article number	Page/Path	Model number
=100-P5	1	Operating hour meter 12 - 48V DC	ABB AG	M10011841	=100/38.1	E233-12/48
=100-GP1	1	Fuel level electric, round d=64 mm	Motometer	M10019161	=100/38.2	609 060 1039
=100-GK26	1	Plug-in base w. relay	Wago GmbH & Co. KG	M10019133 + M10019138	=100/38.4	788-312
=100-GKT1	1	Time-delay relay with led	Siemens	M10014285	=100/38.5	3RP15 25-2AP30
=100-GKT2	1	Time-delay relay with led	Siemens	M10014285	=100/38.8	3RP15 25-2AP30
=100-GS2	1	Push button black	Siemens	2213477	=100/39.6	3SB32 02-0AA11-0CC0
=100-GS2	1	Tag holder	Siemens	3SB39 25-0AV	=100/39.6	3SB39 25-0AV
=100-GH1	1	Signal lamp yellow,with smooth lens	Siemens	3SB32 44-6AA30-0CC0	=100/39.7	3SB32 44-6AA30-0CC0
=100-GH1	1	Tag holder	Siemens	3SB39 25-0AV	=100/39.7	3SB39 25-0AV
=100-GH2	1	Signal lamp yellow,with smooth lens	Siemens	3SB32 44-6AA30-0CC0	=100/39.7	3SB32 44-6AA30-0CC0
=100-GH2	1	Tag holder	Siemens	3SB39 25-0AV	=100/39.7	3SB39 25-0AV
=100-GH3	1	Signal lamp red, with smooth lens	Siemens	3SB32 44-6AA20-0CC0	=100/39.8	3SB32 44-6AA20-0CC0
=100-GH3	1	Tag holder	Siemens	3SB39 25-0AV	=100/39.8	3SB39 25-0AV
=100-SN0	1	Handle 2 switch positions,	Siemens	M10021302	=100/41.1	3SB32 02-2KA11-0CC0
=100-SN0	2	Switching element 1nc	Siemens	M10017539	=100/41.1	3SB34 03-0C
=100-SN0	1	Protecting cap	Siemens	3SB39 21-0BA	=100/41.1	3SB39 21-0BA
=100-SN0	1	Tag holder	Siemens	3SB39 25-0AV	=100/41.1	3SB39 25-0AV
=100-KGA1	1	Auxiliary relay sirius	Siemens	M10014272	=100/41.2	3RH11 22-2BB40
=100-KGA2	1	Plug-in base w. relay	Wago GmbH & Co. KG	M10019133 + M10019138	=100/41.2	788-312
=100-KGA3	1	Plug-in base w. relay	Wago GmbH & Co. KG	M10019133 + M10019138	=100/41.3	788-312
=100-8K04	1	Plug-in base w. relay	Wago GmbH & Co. KG	M10019133 + M10019138	=100/41.4	788-312
=100-8K03	1	Plug-in base w. relay	Wago GmbH & Co. KG	M10019133 + M10019138	=100/41.4	788-312

DATE	18.Apr.2012	KLEEMANN GMBH		 	PART'S LIST	KLEEMANN SERIES	K007	= STK	+
EDITED	JHE	MOBICAT MC 120 Z US				KLEEMANN MATERIAL NO	M20000111_01	CAE-SYSTEM: EPLAN 5.70	PG.
CONTR.	D. MALLKOWSKY	ORIGIN	REP.F.	REP.T.				PG.	12
MODIFICAT.	DATE	NAME	NORM	DIN				PG.	12