



## ELECTRO - DOCUMENTATION

TYPE OF MACHINE : MOBICAT MC 120 Z EU  
KLEEMANN SERIES : K007  
KLEEMANN MATERIAL NO : 2315434

MANUFACTURED FOR : KLEEMANN GMBH  
MANFRED-WÖRNER-STRASSE 160  
D-73037 GÖPPINGEN

MANUFACTURED BY : TPS GMBH  
PHONE-NO. : +49/7161/206-0  
FAX-NO. : +49/7161/206-100  
DATE : 04.Dez.2015

PLC-CONTROL TYPE : VIPA SPS-CPU-214  
LANGUAGE : DEUTSCH/ENGLISH

Neue Bestellnummer  
New order number  
2307616\_00

2

			DATE	03.Apr.2012	KLEEMANN GMBH					DECKBLATT/ COVER SHEET	KLEEMANN SERIES	K007	= A0	+
			EDITED	JHE	MOBICAT MC 120 Z EU						KLEEMANN MATERIAL NO	2315434	CAE-SYSTEM: EPLAN 5.70	PG. 1
MODIFICAT.	DATE	NAME	NORM	DIN	ORIGIN	REP.F.	REP.T.						PG. 19	

# Table of contents

TPS\_PST2 / 31.03.2003

Plant	Location	Page	Page designation	Page supplementary field	Date	Editor
A0		1	DECKBLATT/ COVER SHEET		03.Apr.2012	HV
A0		2	INHALTSVERZEICHNIS/ TABLE OF CONTENTS		04.Dez.2015	PC1
A0		3	INHALTSVERZEICHNIS/ TABLE OF CONTENTS		04.Dez.2015	PC1
A0		4	INHALTSVERZEICHNIS/ TABLE OF CONTENTS		04.Dez.2015	PC1
A0		5	INHALTSVERZEICHNIS/ TABLE OF CONTENTS		04.Dez.2015	PC1
A0		6	INHALTSVERZEICHNIS/ TABLE OF CONTENTS		04.Dez.2015	PC1
A0		19	KLEMMENUEBERSICHT/ TERMINAL OVERVIEW		04.Dez.2015	JHE
100		1	EINSPEISUNG/ INCOMING SUPPLY		05.Aug.2013	HV
100		2	RESERVE/ SPARE		04.Jul.2012	JHE
100		3	BELEUCHTUNG UND BANDWAAGE/ ILLUMINATION AND BELT WEIGHER		06.Mai.2013	HV
100		4	ABGAENGE VOR HAUPTSCHALTER/ OUTLETS BEFORE MAIN SWITCH		06.Mai.2013	HV
100		5	STEUERSpannung/ CONTROL VOLTAGE		05.Aug.2013	JHE
100		6	NOT-AUS/ EMERGENCY STOP		04.Dez.2015	JHE
100		6.1	NOT-AUS SCHALTGERAET/ E-STOP SWITCHGEAR		04.Dez.2015	JHE
100		7	VERSORGUNG 24V STEUERSPG/ SUPPLY 24V CONTROL VOLTAGE		04.Dez.2015	HV
100		8	BRECHER 1/ CRUSHER 1		04.Dez.2015	HV
100		9	STRG BRECHER 1/ CONTROL CRUSHER 1		04.Dez.2015	HV
100		10	MOTOREN/ DRIVES		04.Dez.2015	HV
100		11	MOTOREN/ DRIVES		04.Dez.2015	HV
100		12	MOTOREN/ DRIVES		04.Dez.2015	HV
100		13	MOTOREN/ DRIVES		04.Dez.2015	HV
100		14	AUFGABERINNE 8 - POS. 2/ VIBRATING FEEDER 8 - POS. 2		04.Dez.2015	HV
100		15	RESERVE/ SPARE		04.Dez.2015	HV
100		16	RESERVE/ SPARE		04.Dez.2015	HV
100		17	CPU STEUERUNG/ CPU CONTROL SYSTEM		04.Dez.2015	HV
100		18	ANALOG EINGAENGE/ ANALOG INPUTS		04.Dez.2015	HV
100		19	ANALOG AUSGAENGE/ ANALOG OUTPUTS		04.Dez.2015	HV
100		20	DIGITALE EINGAENGE/ DIGITAL INPUTS		04.Dez.2015	HV
100		21	DIGITALE EINGAENGE/ DIGITAL INPUTS		04.Dez.2015	HV
100		22	DIGITALE AUSGAENGE A 124.0 - A 124.7/ DIGITAL OUTPUTS A 124.0 - A 124.7		04.Dez.2015	HV

DATE		04.Dez.2015		KLEEMANN GMBH		 	INHALTSVERZEICHNIS/ TABLE OF CONTENTS		KLEEMANN SERIES K007		= A0		+	
EDITED		JBR		MOBICAT MC 120 Z EU					KLEEMANN MATERIAL NO 2315434		CAE-SYSTEM: EPLAN 5.70		PG. 2	
MODIFICAT.	DATE	NAME	NORM	DIN	ORIGIN	REP.F.	REP.T.					PG. 19		

# Table of contents

TPS\_PST2 / 31.03.2003

Plant	Location	Page	Page designation	Page supplementary field	Date	Editor
100		23	DIGITALE AUSGAENGE A 125.0 - A 125.7/ DIGITAL OUTPUTS A 125.0 - A 125.7		04.Dez.2015	HV
100		24	DIGITALE EINGAENGE E 0.0 - E 0.7/ DIGITAL INPUTS E 0.0 - E 0.7		04.Dez.2015	HV
100		25	DIGITALE EINGAENGE E 1.0 - E 1.7/ DIGITAL INPUTS E 1.0 - E 1.7		04.Dez.2015	HV
100		26	DIGITAL EINGAENGE E 2.0 - E 2.7/ DIGITAL INPUTS E 2.0 - E 2.7		04.Dez.2015	HV
100		27	DIGITAL EINGAENGE E 3.0 - E 3.7/ DIGITAL INPUTS E 3.0 - E 3.7		04.Dez.2015	HV
100		28	DIGITAL EINGAENGE E 4.0 - E 4.7/ DIGITAL INPUTS E 4.0 - E 4.7		04.Dez.2015	HV
100		29	DIGITALE EINGAENGE E 5.0 - E 5.7/ DIGITAL INPUTS E 5.0 - E 5.7		04.Dez.2015	HV
100		30	DIGITALE AUSGAENGE A 6.0 - A 6.7/ DIGITAL OUTPUTS A 6.0 - A 6.7		04.Dez.2015	HV
100		31	DIGITALE AUSGAENGE A 7.0 - A 7.7/ DIGITAL OUTPUTS A 7.0 - A 7.7		04.Dez.2015	HV
100		32	DIGITALE EINGAENGE E 8.0 - E 8.7/ DIGITAL INPUTS E 8.0 - E 8.7		04.Dez.2015	HV
100		33	DIGITALE EINGAENGE E 9.0 - E 9.7/ DIGITAL INPUTS E 9.0 - E 9.7		04.Dez.2015	HV
100		34	DIGITALE AUSGAENGE A 10.0 - A 10.7/ DIGITAL OUTPUTS A 10.0 - A 10.7		04.Dez.2015	HV
100		35	DIGITALE AUSGAENGE A 11.0 - A 11.7/ DIGITAL OUTPUTS A 11.0 - A 11.7		04.Dez.2015	HV
100		36	LICHTSCHRANKE BRECHER/ LIGHT BARRIER CRUSHER		04.Dez.2015	HV
100		37	MOTORUEBERWACHUNG/ MOTOR CONTROLLING		04.Dez.2015	HV
100		38	KOORDINATOR/ COORDINATOR		04.Dez.2015	HV
100		39	EMS		04.Dez.2015	JHE
100		40	BETRIEBSINSTRUMENTE/ OPERATIONAL INSTRUMENTS		04.Dez.2015	HV
100		41	FUNKFERNSTEUERUNG/ RADIO REMOTE CONTROL		04.Dez.2015	HV
KLE		1	KLEMMENLEISTENUEBERSICHT/ TERMINAL STRIP OVERVIEW		13.Mai.2013	PC1
KLE		2	STECKERUEBERSICHT/ PLUG OVERVIEW		13.Mai.2013	PC1
KLE		10	KLEMMENLEISTE -X0/ TERMINAL STRIP -X0		06.Mai.2013	PC1
KLE		11	KLEMMLEISTE -X1/ TERMINAL STRIP -X1		06.Mai.2013	PC1
KLE		12	KLEMMLEISTE -X1/ TERMINAL STRIP -X1		06.Mai.2013	PC1
KLE		13	KLEMMENLEISTE -X3/ TERMINAL STRIP -X3		06.Mai.2013	PC1
KLE		14	KLEMMLEISTE -X6/ TERMINAL STRIP -X6		06.Mai.2013	PC1
KLE		15	KLEMMENLEISTE -X8/ TERMINAL STRIP -X8		06.Mai.2013	PC1
KLE		16	KLEMMENLEISTE -X00/ TERMINAL STRIP -X00		06.Mai.2013	PC1
KLE		17	KLEMMENLEISTE -X00/ TERMINAL STRIP -X00		06.Mai.2013	PC1
KLE		18	KLEMMLEISTE -X22/ TERMINAL STRIP -X22		06.Mai.2013	PC1

DATE		04.Dez.2015		KLEEMANN GMBH		 	INHALTSVERZEICHNIS/ TABLE OF CONTENTS		KLEEMANN SERIES K007		= A0		+	
EDITED		JBR		MOBICAT MC 120 Z EU					KLEEMANN MATERIAL NO 2315434		CAE-SYSTEM: EPLAN 5.70		PG. 3	
MODIFICAT.	DATE	NAME	NORM	DIN	ORIGIN	REP.F.	REP.T.					PG. 19		

# Table of contents

TPS\_PST2 / 31.03.2003

Plant	Location	Page	Page designation	Page supplementary field	Date	Editor
KLE		19	KLEMMENLEISTE -X230/ TERMINAL STRIP -X230		06.Mai.2013	PC1
KLE		20	KLEMMENLEISTE -XB/ TERMINAL STRIP -XB		06.Mai.2013	PC1
KLE		21	KLEMMLEISTE -XF/ TERMINAL STRIP -XF		06.Mai.2013	PC1
KLE		22	KLEMMENLEISTE -XG/ TERMINAL STRIP -XG		06.Mai.2013	PC1
KLE		23	KLEMMENLEISTE -XK/ TERMINAL STRIP -XK		06.Mai.2013	PC1
KLE		24	KLEMMLEISTE -XLS TERMINAL STRIP -XLS		06.Mai.2013	PC1
KLE		25	KLEMMLEISTE -0X0/ TERMINAL STRIP -0X0		06.Mai.2013	PC1
KLE		26	KLEMMLEISTE -0X06/ TERMINAL STRIP -0X06		06.Mai.2013	PC1
KLE		27	KLEMMENLEISTE -0X07/ TERMINAL STRIP -0X07		06.Mai.2013	PC1
KLE		28	KLEMMENLEISTE +M-XG/ TERMINAL STRIP +M-XG		06.Mai.2013	PC1
KLE		29	STECKER -XOUT/ PLUG -XOUT		06.Mai.2013	PC1
KLE		30	STECKER -3X2/ PLUG -3X2		06.Mai.2013	PC1
KLE		31	STECKER -4X1/ PLUG -4X1		06.Mai.2013	PC1
KLE		32	STECKER -4X2/ PLUG -4X2		06.Mai.2013	PC1
KLE		33	STECKER +M-XF1 PLUG +M-XF1		06.Mai.2013	PC1
KLE		34	STECKER +M-XS2/ PLUG +M-XS2		06.Mai.2013	PC1
KLE		35	STECKER +M-XS5/ PLUG +M-XS5		06.Mai.2013	PC1
KLE		36	STECKER +M-6X1/ PLUG +M-6X1		06.Mai.2013	PC1
KAB		1	KABELUEBERSICHT/ CABLE SURVEY		13.Mai.2013	PC1
KAB		2	KABELUEBERSICHT/ CABLE SURVEY		13.Mai.2013	PC1
KAB		10	-03W1		06.Mai.2013	PC1
KAB		11	-03W2		06.Mai.2013	PC1
KAB		12	-06W1		06.Mai.2013	PC1
KAB		13	-06W2		06.Mai.2013	PC1
KAB		14	-06W3		06.Mai.2013	PC1
KAB		15	-06W4		06.Mai.2013	PC1
KAB		16	-06W5		06.Mai.2013	PC1
KAB		17	-06W6		06.Mai.2013	PC1
KAB		18	-06W7		06.Mai.2013	PC1
KAB		19	-06W8		06.Mai.2013	PC1

# Table of contents

TPS\_PST2 / 31.03.2003

Plant	Location	Page	Page designation	Page supplementary field	Date	Editor
KAB		20	-06W12		06.Mai.2013	PC1
KAB		21	-06W15		06.Mai.2013	PC1
KAB		22	-07W1		06.Mai.2013	PC1
KAB		23	-07W2		06.Mai.2013	PC1
KAB		24	-07W3		06.Mai.2013	PC1
KAB		25	-10W1		06.Mai.2013	PC1
KAB		26	-10W2		06.Mai.2013	PC1
KAB		27	-10W3		06.Mai.2013	PC1
KAB		28	-11W1		06.Mai.2013	PC1
KAB		29	-11W2		06.Mai.2013	PC1
KAB		30	-11W3		06.Mai.2013	PC1
KAB		31	-12W1		06.Mai.2013	PC1
KAB		32	-12W2		06.Mai.2013	PC1
KAB		33	-12W3		06.Mai.2013	PC1
KAB		34	-12W4		06.Mai.2013	PC1
KAB		35	-13W1		06.Mai.2013	PC1
KAB		36	-13W2		06.Mai.2013	PC1
KAB		37	-13W3		06.Mai.2013	PC1
KAB		38	-14W1		06.Mai.2013	PC1
KAB		39	-14W2		06.Mai.2013	PC1
KAB		40	-36W1		06.Mai.2013	PC1
KAB		41	-36W2		06.Mai.2013	PC1
KAB		42	-37W1		06.Mai.2013	PC1
KAB		43	-37W2		06.Mai.2013	PC1
KAB		44	-41W1		06.Mai.2013	PC1
KAB		45	-41W2		06.Mai.2013	PC1
KAB		46	-41W3		06.Mai.2013	PC1
KAB		47	-41W4		06.Mai.2013	PC1
KAB		48	-41W5		06.Mai.2013	PC1
STK		1	STUECKLISTE		04.Dez.2015	JHE

# Table of contents

TPS\_PST2 / 31.03.2003

Plant	Location	Page	Page designation	Page supplementary field	Date	Editor
STK		2	STUECKLISTE		04.Dez.2015	JHE
STK		3	STUECKLISTE		04.Dez.2015	JHE
STK		4	STUECKLISTE		04.Dez.2015	JHE
STK		5	STUECKLISTE		04.Dez.2015	JHE
STK		6	STUECKLISTE		04.Dez.2015	JHE
STK		7	PART'S LIST		04.Dez.2015	JHE
STK		8	PART'S LIST		04.Dez.2015	JHE
STK		9	PART'S LIST		04.Dez.2015	JHE
STK		10	PART'S LIST		04.Dez.2015	JHE
STK		11	PART'S LIST		04.Dez.2015	JHE
STK		12	PART'S LIST		04.Dez.2015	JHE
STK		13	PART'S LIST		04.Dez.2015	JHE

# KLEMMLEISTENBEZEICHNUNG/ TERMINAL STRIP DESIGNATION

-0X0 = KLEMMLEISTE -0X0/  
TERMINAL STRIP -0X0

-0X06 =KLEMMLEISTE -0X06/  
TERMINAL STRIP -0X06

-0X07 = KLEMMENLEISTE -0X07/  
TERMINAL STRIP -0X07

-X00 =KLEMMENLEISTE -X00/  
TERMINAL STRIP -X00

-X0 =KLEMMENLEISTE -X0/  
TERMINAL STRIP -X0

-X1 = KLEMMLEISTE -X1/  
TERMINAL STRIP -X1

-X3 =KLEMMENLEISTE -X3/  
TERMINAL STRIP -X3

-X6 = KLEMMLEISTE -X6/  
TERMINAL STRIP -X6

-X8 = KLEMMENLEISTE -X8/  
TERMINAL STRIP -X8

-X22 = KLEMMLEISTE -X22/  
TERMINAL STRIP -X22

-X230 = KLEMMENLEISTE -X230/  
TERMINAL STRIP -X230

-XB = KLEMMENLEISTE -XB/  
TERMINAL STRIP -XB

-XF = KLEMMLEISTE -XF/  
TERMINAL STRIP -XF

-XG = KLEMMENLEISTE -XG/  
TERMINAL STRIP -XG

-XK = KLEMMENLEISTE -XK/  
TERMINAL STRIP -XK

+M-XG = KLEMMENLEISTE +M-XG/  
TERMINAL STRIP +M-XG

-XLS = KLEMMLEISTE -XLS  
TERMINAL STRIP -XLS

# STECKERBEZEICHNUNG/ PLUG DESIGNATION

-XOUT = STECKER -XOUT/  
PLUG -XOUT

-3X2 = STECKER -3X2/  
PLUG -3X2

-4X1 = STECKER -4X1/  
PLUG -4X1

-4X2 = STECKER -4X2/  
PLUG -4X2

+M-XF1 = STECKER +M-XF1  
PLUG +M-XF1

+M-6X1 = STECKER +M-6X1/  
PLUG +M-6X1

+M-XS2 = STECKER +M-XS2/  
PLUG +M-XS2

+M-XS5 = STECKER +M-XS5/  
PLUG +M-XS5

		DATE	04.Dez.2015		KLEEMANN GMBH			 	KLEMMENUEBERSICHT/ TERMINAL OVERVIEW	KLEEMANN SERIES	K007	= A0	+
		EDITED	JBR		MOBICAT MC 120 Z EU					KLEEMANN MATERIAL NO	2315434	CAE-SYSTEM: EPLAN 5.70	PG. 19
MODIFICAT.	DATE	NAME	NORM	DIN	ORIGIN	REP.F.	REP.T.				PG. 19		

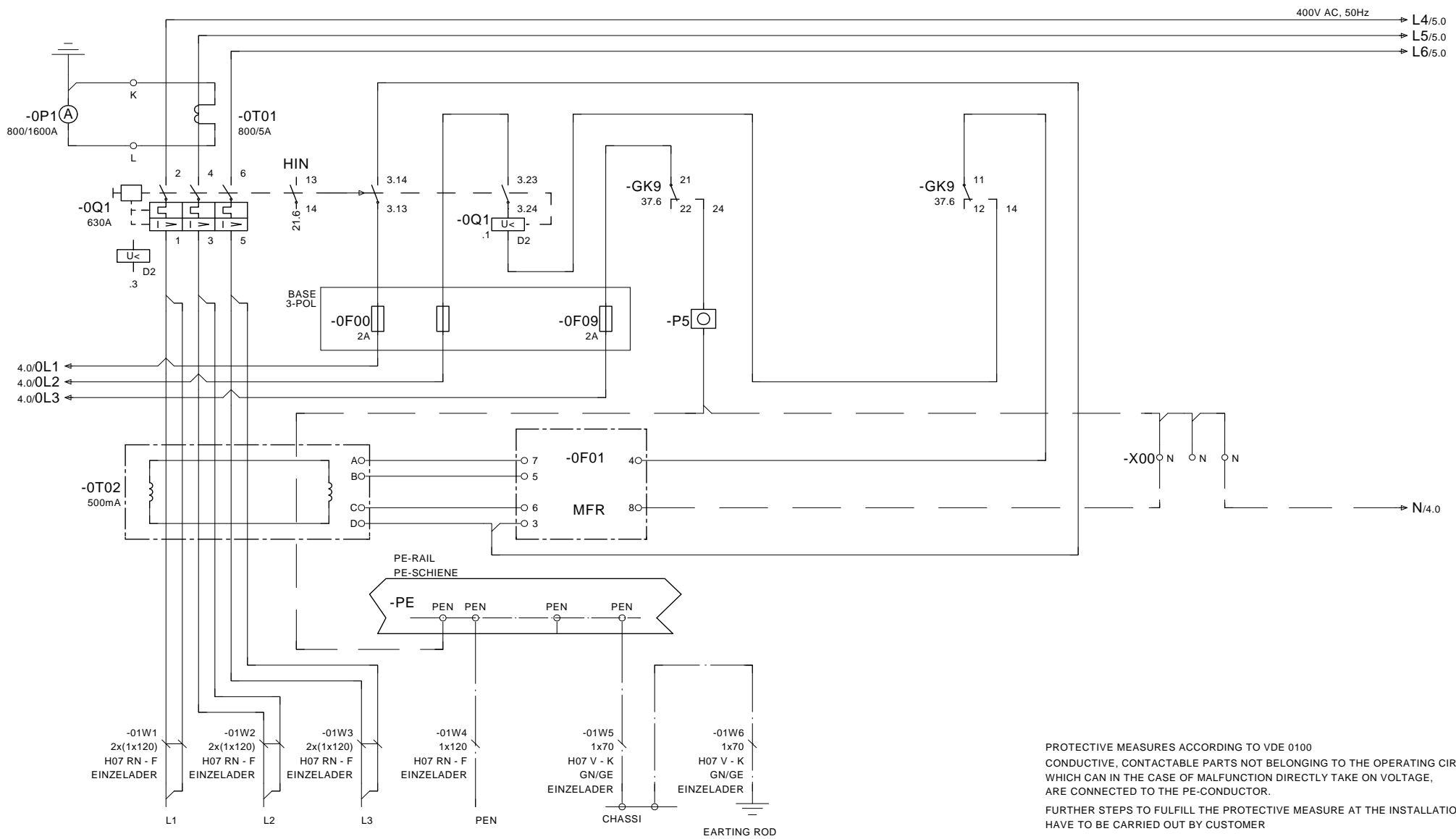

INCOMING SUPPLY 3X400V/PE/50Hz  
POWER SUPPLY FROM GENERATOR

EINSPEISUNG 3X400V/PE/50Hz  
ENERGIEVERSORGUNG VON GENERATOR

TOTAL FAULT  
CURRENT PROTECTION

FI-SCHUTZ  
GESAMT

PROTECTIVE MEASURES ACCORDING TO VDE 0100  
CONDUCTIVE, CONTACTABLE PARTS NOT BELONGING TO THE OPERATING CIRCUIT,  
WHICH CAN IN THE CASE OF MALFUNCTION DIRECTLY TAKE ON VOLTAGE,  
ARE CONNECTED TO THE PE-CONDUCTOR.  
FURTHER STEPS TO FULFILL THE PROTECTIVE MEASURE AT THE INSTALLATION SITE,  
HAVE TO BE CARRIED OUT BY CUSTOMER

SCHUTZMASSNAHME NACH VDE 0100  
NICHT ZUM BETRIEBSSTROMKREIS GEHOERENDE, LEITFAEHIGE BERUEHRBARE TEILE  
DIE IM FEHLERFALL UNMITTELBAR SPANNUNG ANNEHMEN KOENNEN, SIND MIT DEM  
PE-LEITER VERBUNDEN.

WEITERE MASSNAHMEN ZUR ERFUELLUNG DER SCHUTZMASSNAHME AM AUFSTELLUNGSORT  
BAUSEITS DURCHFUEHREN

=A0/19

2

			DATE	05.Aug.2013	KLEEMANN GMBH			 EINSPEISUNG/ INCOMING SUPPLY	KLEEMANN SERIES	K007	= 100	+
			EDITED	PC1	MOBICAT MC 120 Z EU				KLEEMANN MATERIAL NO	2315434	CAE-SYSTEM: EPLAN 5.70	PG. 41
MODIFICAT.	DATE	NAME	NORM	DIN	ORIGIN	REP.F.	REP.T.					



0	1	2	3	4	5	6	7	8	9
---	---	---	---	---	---	---	---	---	---

1

3

			DATE	04.Jul.2012	KLEEMANN GMBH			 	RESERVE/ SPARE	KLEEMANN SERIES	K007	= 100	+
			EDITED	JHE	MOBICAT MC 120 Z EU					KLEEMANN MATERIAL NO	2315434	CAE-SYSTEM: EPLAN 5.70	PG. 41
MODIFICAT.	DATE	NAME	NORM	DIN	ORIGIN	REP.F.	REP.T.						

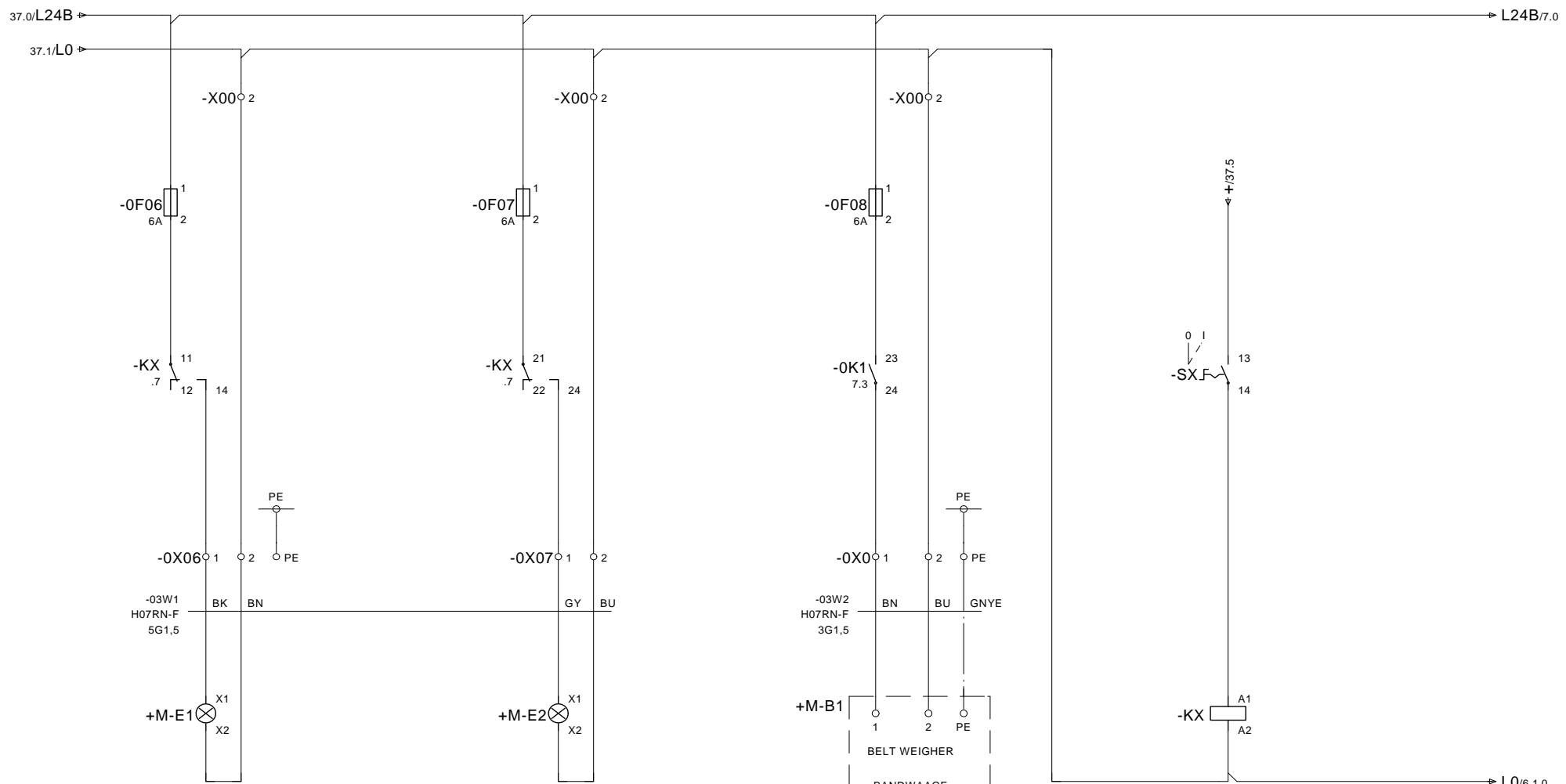

ILLUMINATION 1  
BELEUCHTUNG 1

ILLUMINATION 2  
BELEUCHTUNG 2

BELT WEIGHER  
BANDWAAGE

WAGO 788-312  
14 → 11.1  
12 → 11.1  
24 → 21.3  
22 → 21.3

MODIFICAT.	DATE	NAME	NORM	DIN	ORIGIN	REP.F.	REP.T.	BELEUCHTUNG UND BANDWAAGE/ ILLUMINATION AND BELT WEIGHER	KLEEMANN SERIES K007	= 100	+
									KLEEMANN MATERIAL NO 2315434	CAE-SYSTEM: EPLAN 5.70	PG. 41
											3



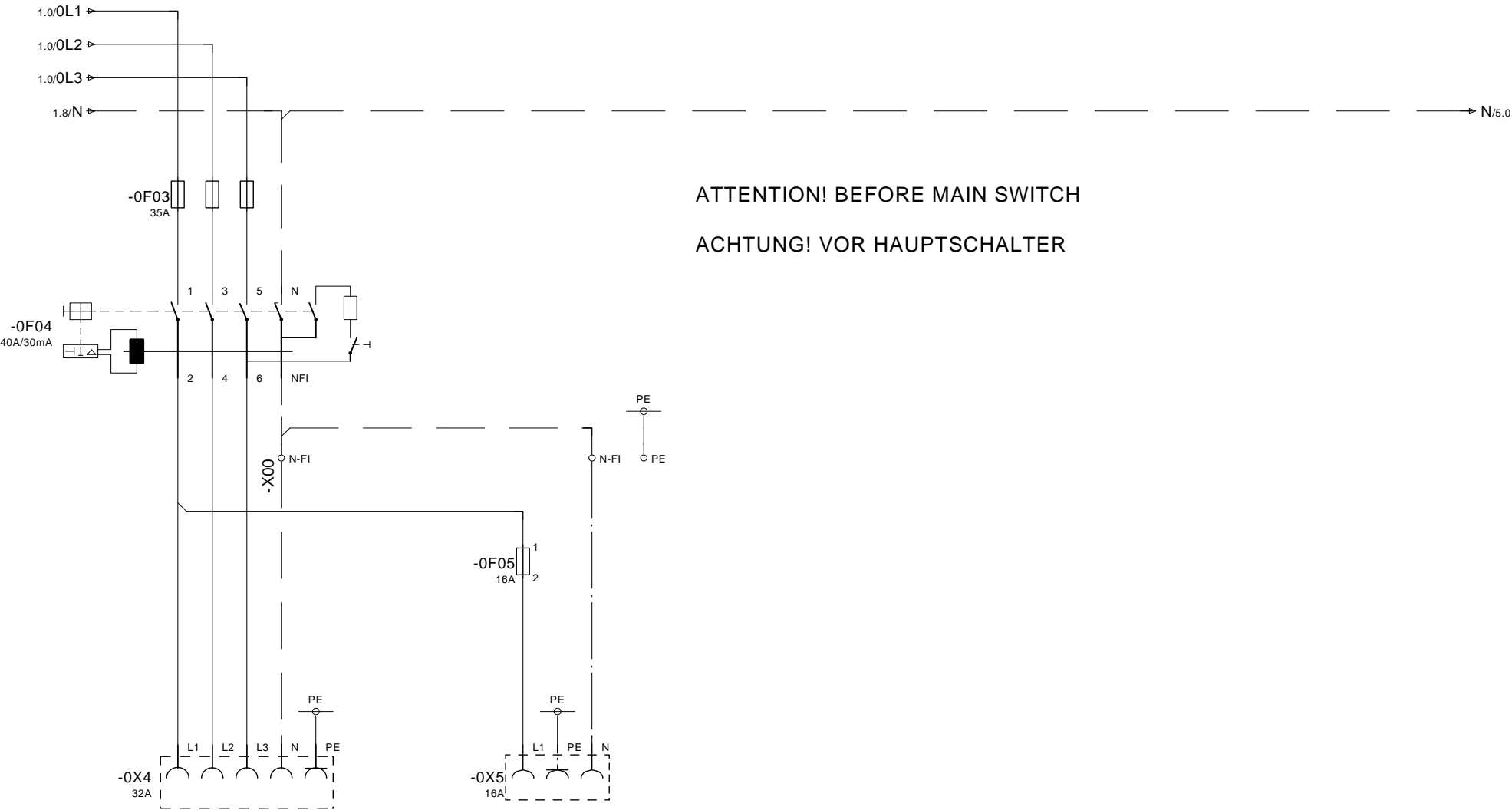

ATTENTION! BEFORE MAIN SWITCH  
 ACHTUNG! VOR HAUPTSCHALTER

SOCKET 32A

SOCKET 16A/230V

STECKDOSE 32A

STECKDOSE 16A/230V

DATE	06.Mai.2013
EDITED	PC1
CONTR.	D. MALLKOWSKY

KLEEMANN GMBH  
 MOBICAT MC 120 Z EU



ABGAENGE VOR HAUPTSCHALTER/  
 OUTLETS BEFORE MAIN SWITCH

KLEEMANN SERIES K007

KLEEMANN MATERIAL NO 2315434

= 100

CAE-SYSTEM: EPLAN 5.70

+

PG. 4  
 PG. 41

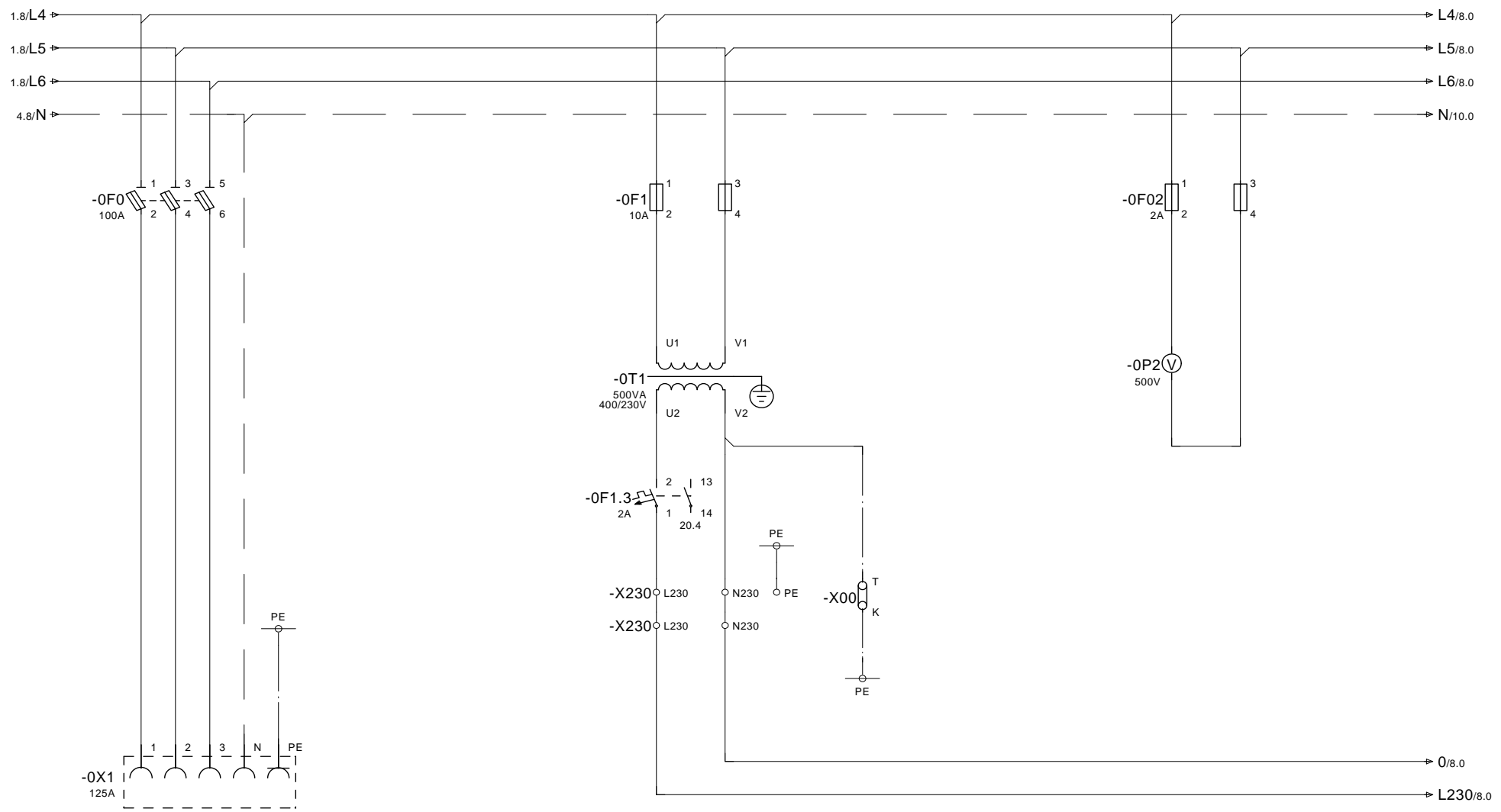

POWER SOCKET 125A

KRAFTSTECKDOSE 125A

		DATE	05.Aug.2013		KLEEMANN GMBH			 <b>Kleemann</b>	STEUERSpannung/ CONTROL VOLTAGE	KLEEMANN SERIES	K007	= 100	+
		EDITED	PC1		MOBICAT MC 120 Z EU					KLEEMANN MATERIAL NO	2315434	CAE-SYSTEM: EPLAN 5.70	PG.
MODIFICAT.	DATE	NAME	NORM	DIN	ORIGIN	REP.F.	REP.T.					PG.	41

7.4/L24VN → L24VN/6.1.0

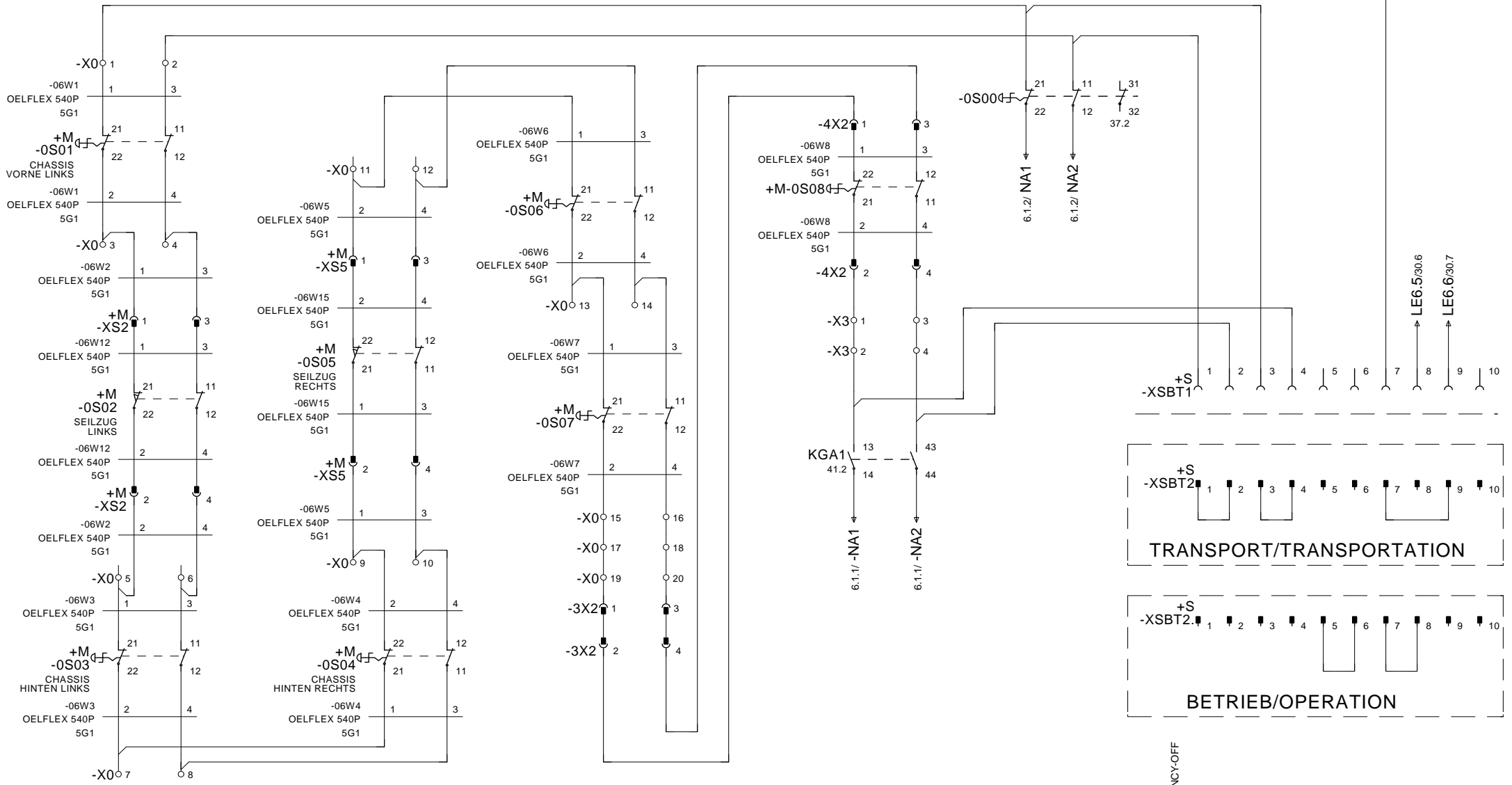

E-STOP PUSH-BUTTON

E-STOP PUSH-BUTTON

NOT-AUS TASTER

NOT-AUS TASTER

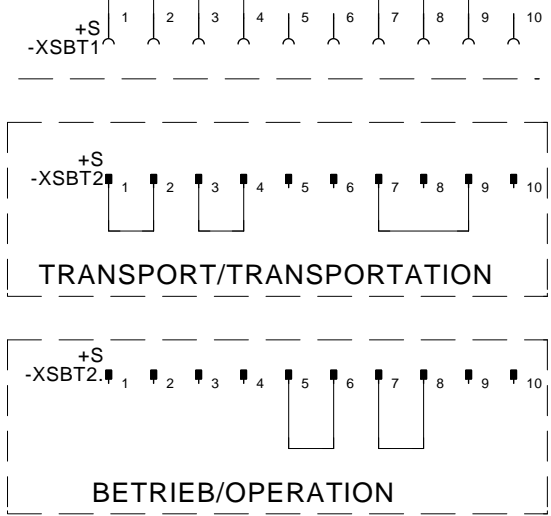

BYPASS EMERGENCY-OFF

+24V SUPPLY

BETRIEB

TRANSPORT

		DATE	04.Dez.2015	KLEEMANN GMBH		 	NOT-AUS/ EMERGENCY STOP	KLEEMANN SERIES	K007	= 100	+
		EDITED	JBR	MOBICAT MC 120 Z EU				KLEEMANN MATERIAL NO	2315434	CAE-SYSTEM: EPLAN 5.70	PG.
MODIFICAT.	DATE	NAME	NORM	DIN	ORIGIN	REP.F.	REP.T.			PG.	41

6.9/L24VN → L24VN/8.4

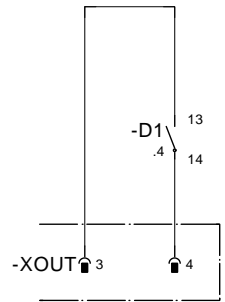
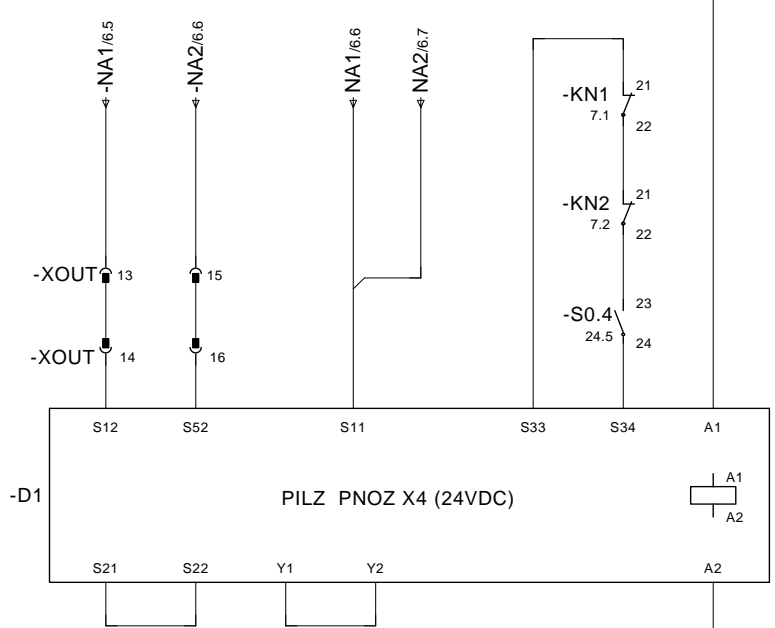

3.8/L0 → L0/7.0

E-STOP SWITCHGEAR  
NOT-AUS SCHALTGERAET

PNOZ X4  
13 — 14 .5  
23 — 24 7.1  
33 — 34 7.1  
41 — 42

		DATE	04.Dez.2015		KLEEMANN GMBH				NOT-AUS SCHALTGERAET/ E-STOP SWITCHGEAR	KLEEMANN SERIES	K007	= 100	+
		EDITED	JBR		MOBICAT MC 120 Z EU					KLEEMANN MATERIAL NO	2315434	CAE-SYSTEM: EPLAN 5.70	PG. 6.1
MODIFICAT.	DATE	NAME	NORM	DIN	ORIGIN	REP.F.	REP.T.				PG. 41		

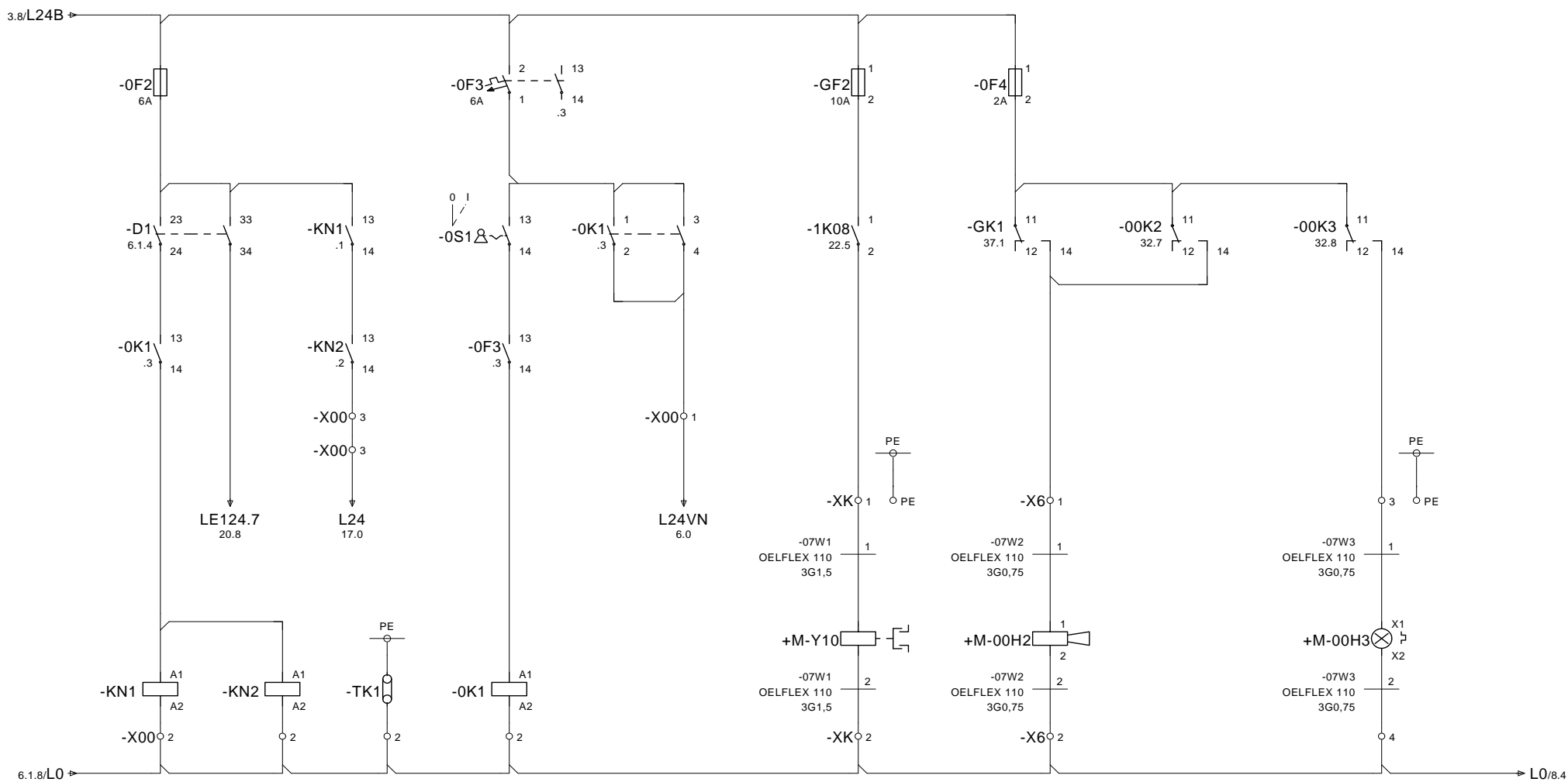

<p>SIE 3RH2122-2BB40</p> <p>13 - 14 .2 21 - 22 6.1.3 31 - 32 43 - 44</p> <p>SUPPLY 24V AFTER EMERGENCY STOP</p> <p>VERSORGUNG 24V NACH NOT-AUS</p>	<p>SIE 3RH2122-2BB40</p> <p>13 - 14 .2 21 - 22 6.1.3 31 - 32 43 - 44</p> <p>SIE 3RT2016-2BB41 3RH29 11-2FA22</p> <p>1 - 2 .4 3 - 4 .4 5 - 6 21.7 13 - 14 .1 23 - 24 3.5 31 - 32 41 - 42 53 - 54</p> <p>CONTROL VOLTAGE ON</p> <p>STEUERSPANNUNG EIN</p>	<p>COUPLING KUPPLUNG</p> <p>HOOTER HUPE</p> <p>FLASHING LIGHT BLINKLICHT</p>
--	---	--

		DATE	04.Dez.2015	KLEEMANN GMBH		VERSORGUNG 24V STEUERSPG/ SUPPLY 24V CONTROL VOLTAGE	KLEEMANN SERIES	K007	= 100	+
		EDITED	JBR	MOBICAT MC 120 Z EU			KLEEMANN MATERIAL NO	2315434	CAE-SYSTEM: EPLAN 5.70	PG. 41
MODIFICAT.	DATE	NAME	NORM	DIN	ORIGIN	REP.F.	REP.T.			

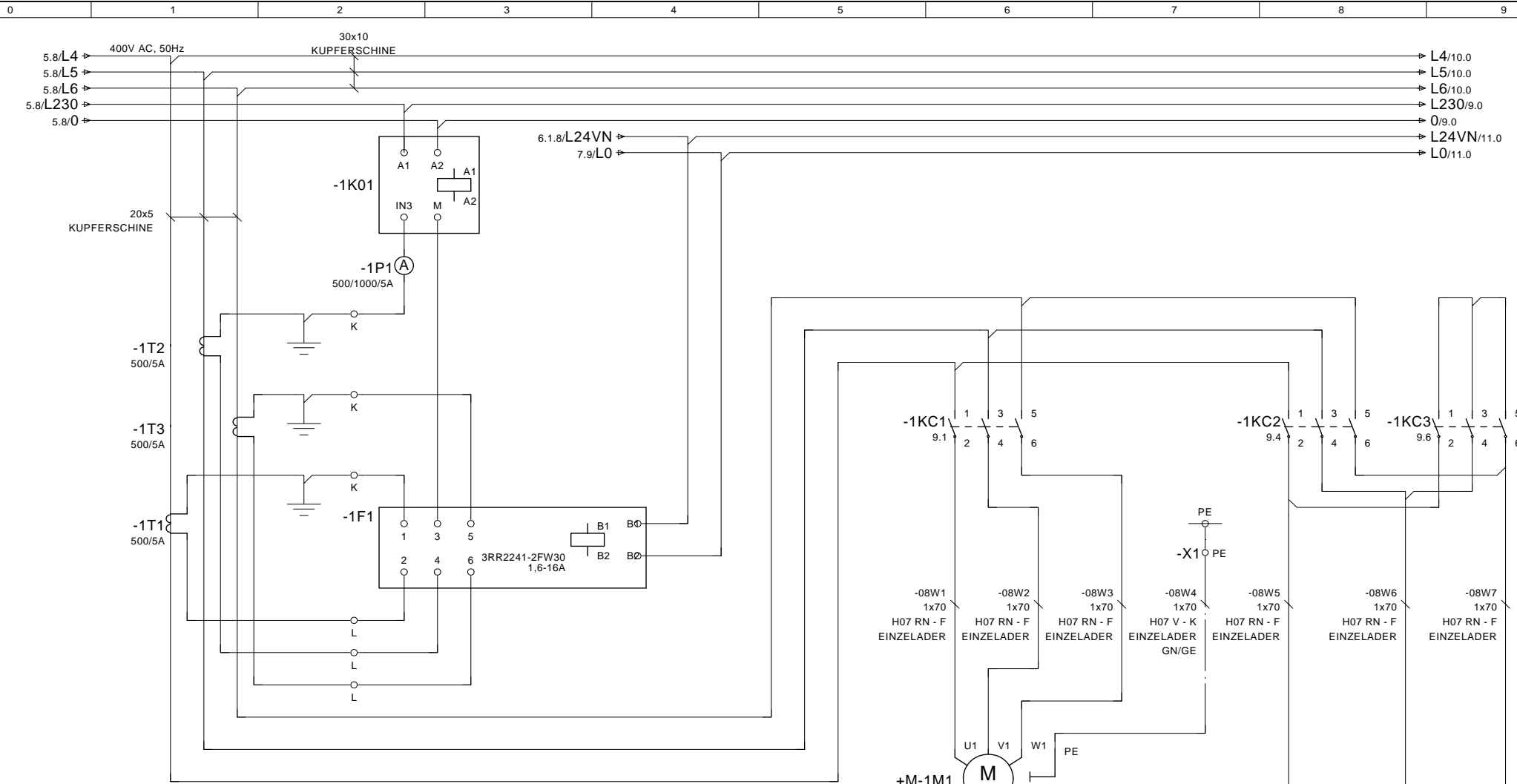

MOTOR PROTECTION RELAY

MOTORSCHUTZRELAIS

CRUSHER 1

BRECHER 1

SIE 3UG46 22-2AW30

SIE 3RR2241-2FW30

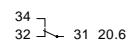
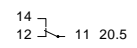

		DATE	04.Dez.2015		KLEEMANN GMBH		<b>kleemann</b>	BRECHER 1/ CRUSHER 1		KLEEMANN SERIES	K007		= 100	+
		EDITED	JBR		MOBICAT MC 120 Z EU						KLEEMANN MATERIAL NO	2315434		CAE-SYSTEM: EPLAN 5.70
MODIFICAT.	DATE	NAME	NORM	DIN	ORIGIN	REP.F.	REP.T.						PG. 41	



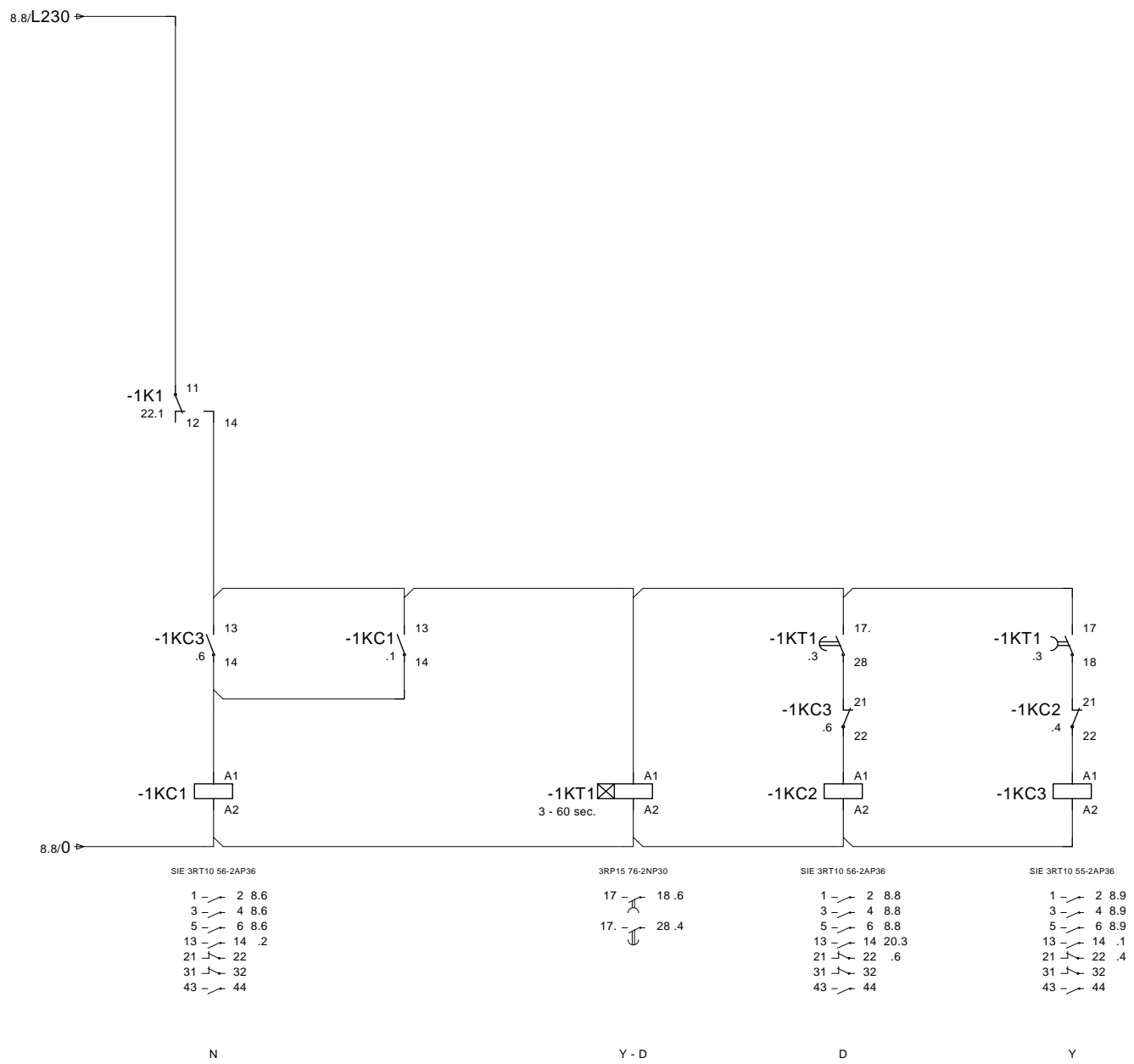

- |  |                        |   |   |
|--|------------------------|---|---|
| SIE 3RT10 56-2AP36   | 3RP15 76-2NP30         | SIE 3RT10 56-2AP36  | SIE 3RT10 55-2AP36  |
| 1 - 2 8.6<br>3 - 4 8.6<br>5 - 6 8.6<br>13 - 14 .2<br>21 - 22<br>31 - 32<br>43 - 44 | 17 - 18.6<br>17 - 28.4 | 1 - 2 8.8<br>3 - 4 8.8<br>5 - 6 8.8<br>13 - 14 20.3<br>21 - 22 .6<br>31 - 32<br>43 - 44 | 1 - 2 8.9<br>3 - 4 8.9<br>5 - 6 8.9<br>13 - 14 .1<br>21 - 22 .4<br>31 - 32<br>43 - 44 |

N Y - D D Y

DATE	04.Dez.2015	KLEEMANN GMBH		 <b>Kleemann</b>	STRG BRECHER 1/ CONTROL CRUSHER 1	KLEEMANN SERIES	K007	= 100	+
EDITED	JBR	MOBICAT MC 120 Z EU				KLEEMANN MATERIAL NO	2315434	CAE-SYSTEM: EPLAN 5.70	PG.
CONTR.	D. MALLKOWSKY	ORIGIN	REP.F.	REP.T.				PG.	41

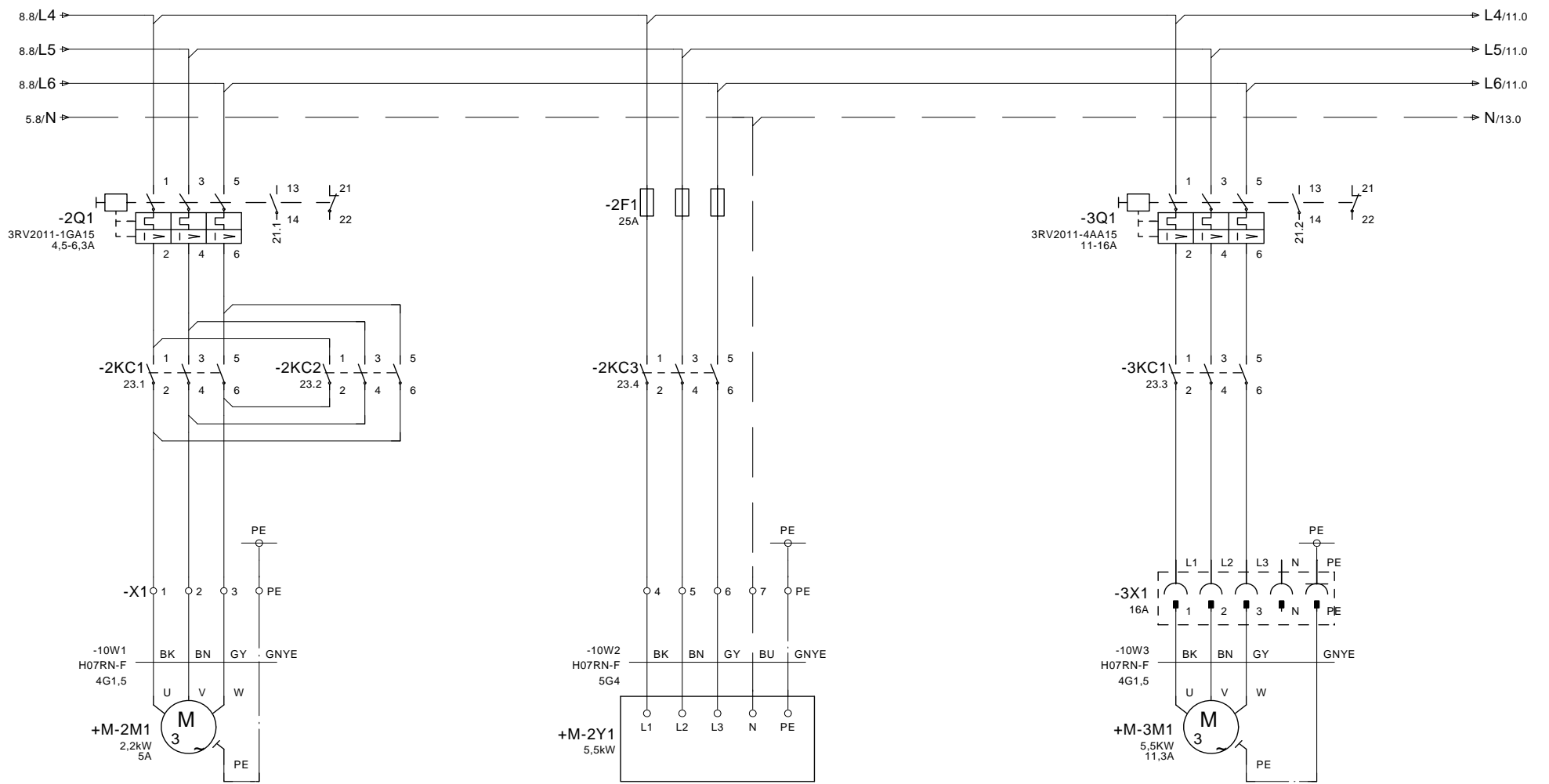

MAGNETIC BELT 2  
MAGNETBAND 2

MAGNET  
MAGNET

CONVEYOR BELT 3  
FOERDERBAND 3

		DATE	04.Dez.2015		KLEEMANN GMBH			 	MOTOREN/ DRIVES	KLEEMANN SERIES	K007	= 100	+
		EDITED	JBR		MOBICAT MC 120 Z EU					KLEEMANN MATERIAL NO	2315434	CAE-SYSTEM: EPLAN 5.70	PG. 10
MODIFICAT.	DATE	NAME	NORM	DIN	ORIGIN	REP.F.	REP.T.				PG. 41		

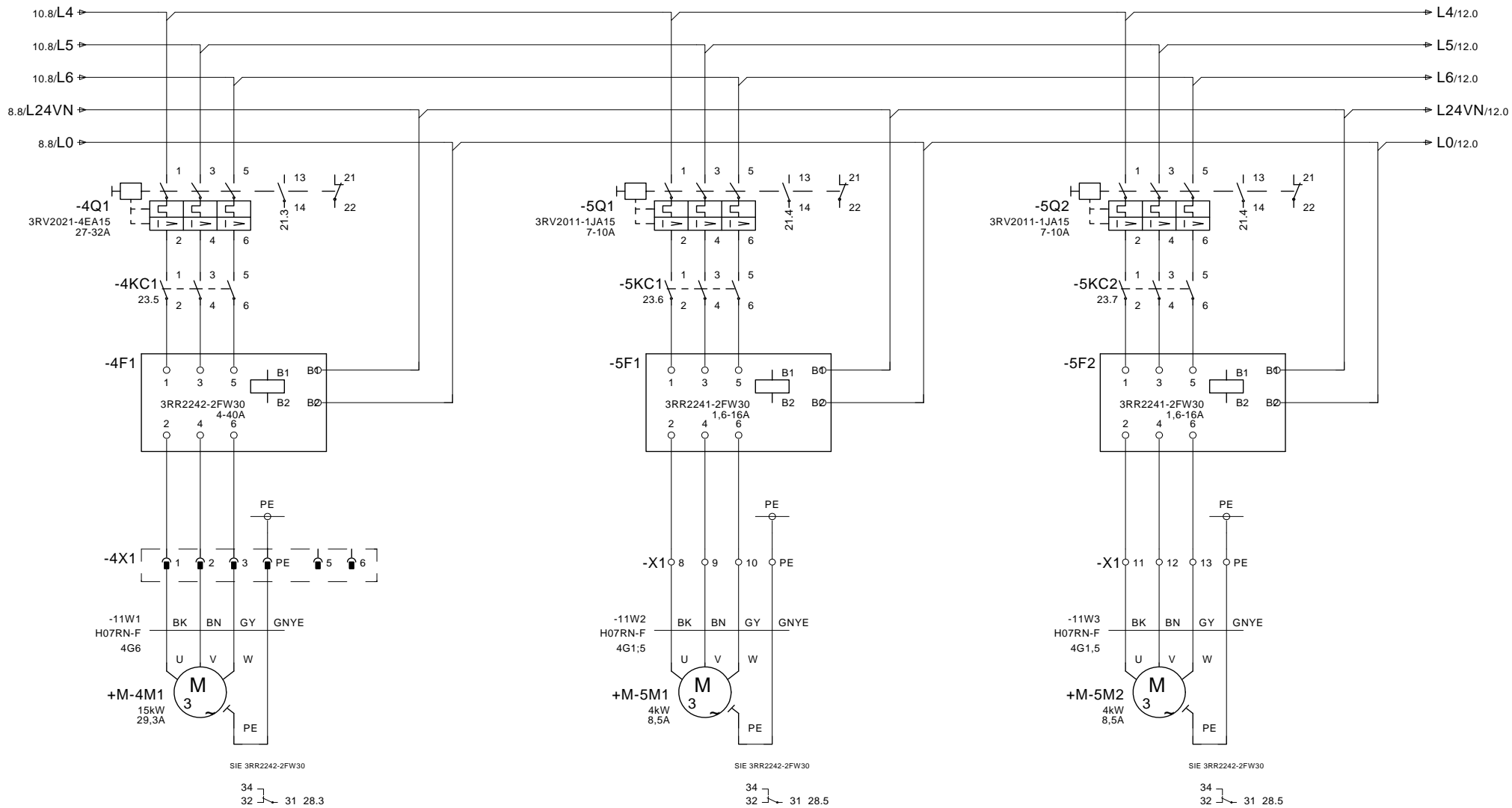

CONVEYOR BELT 4

VIBRATING CHUTE/CRUSHER 5

VIBRATING CHUTE/CRUSHER 5

FOERDERBAND 4

FOERDERRINNE 5

FOERDERRINNE 5

		DATE	04.Dez.2015		KLEEMANN GMBH		 	MOTOREN/ DRIVES	KLEEMANN SERIES	K007	= 100	+
		EDITED	JBR		MOBICAT MC 120 Z EU				KLEEMANN MATERIAL NO	2315434	CAE-SYSTEM: EPLAN 5.70	PG.
MODIFICAT.	DATE	NAME	NORM	DIN	ORIGIN	REP.F.	REP.T.				PG.	41

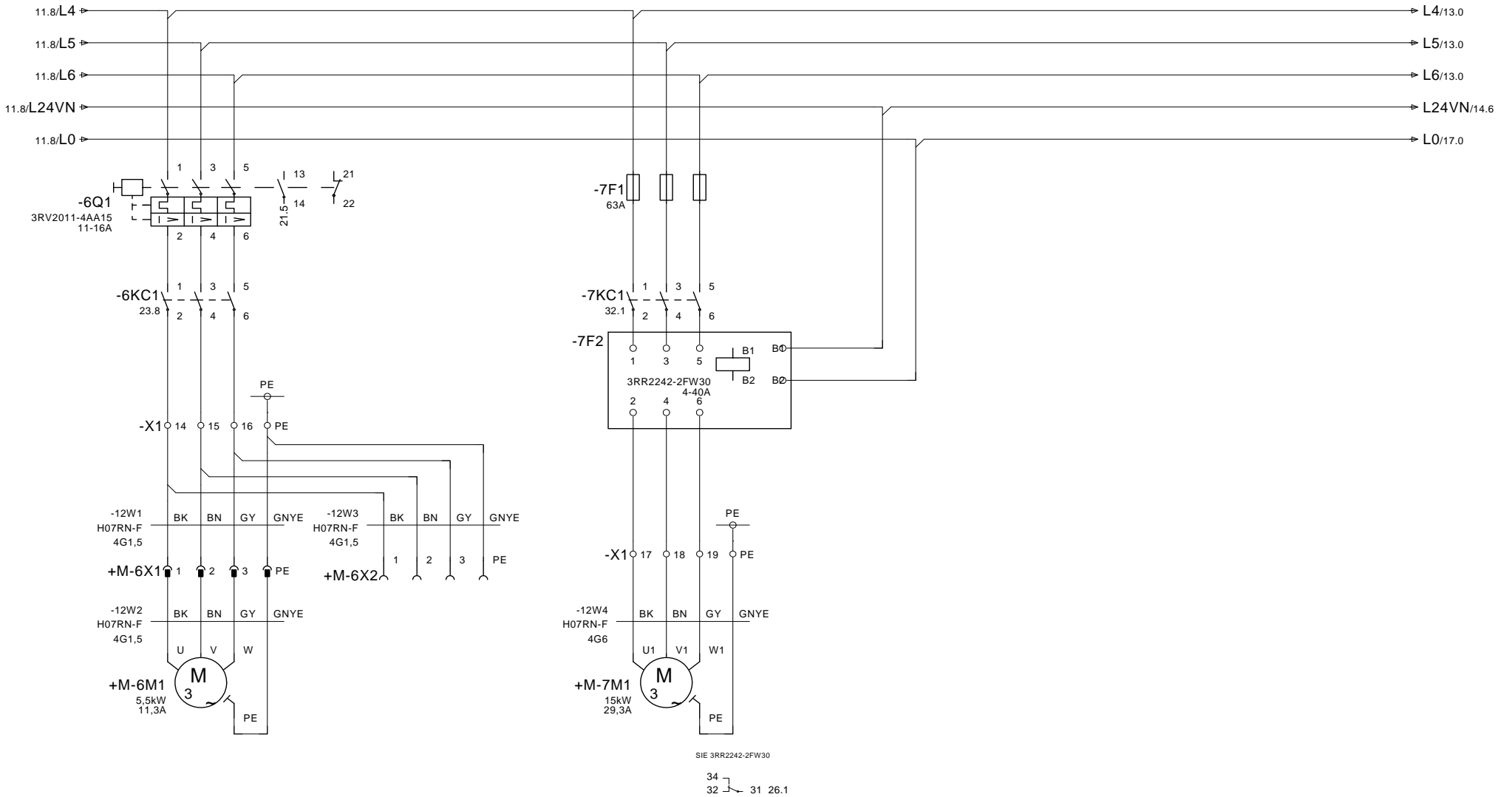

CONVEYOR BELT 6

VIBRATING SCREEN 7

FOERDERBAND 6

VIBRATIONSSIEB 7

		DATE	04.Dez.2015		KLEEMANN GMBH			  MOTOREN/ DRIVES	KLEEMANN SERIES	K007	= 100	+
		EDITED	JBR		MOBICAT MC 120 Z EU				KLEEMANN MATERIAL NO	2315434	CAE-SYSTEM: EPLAN 5.70	PG. 41
MODIFICAT.	DATE	NAME	NORM	DIN	ORIGIN	REP.F.	REP.T.					

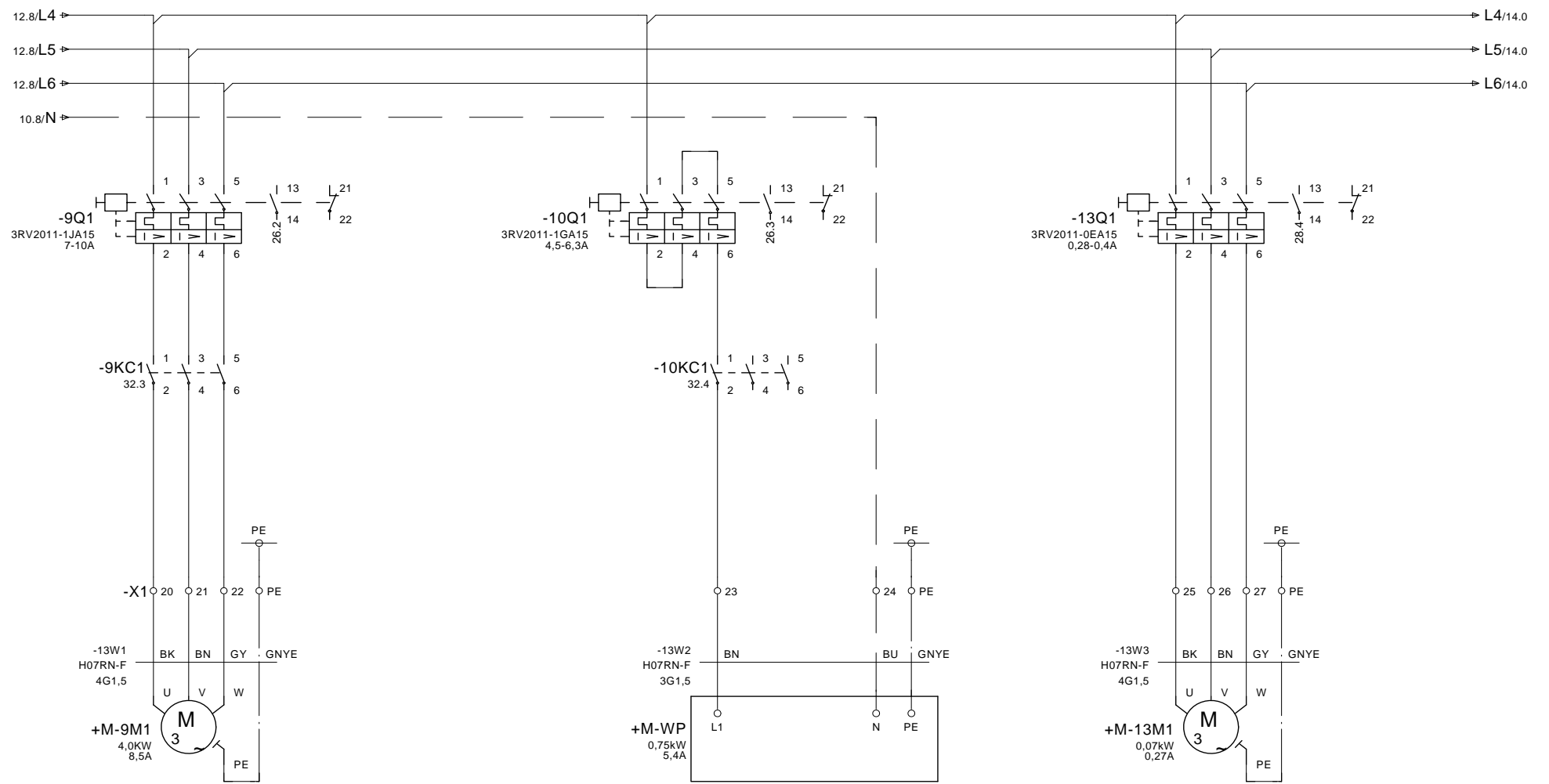

HYDRAULIC 9

WATERPUMP 10

OVERPRESSURE FAN

HYDRAULIK 9

WASSERPUMPE 10

UEBERDRUCKGEBLAESE

		DATE	04.Dez.2015		KLEEMANN GMBH			 	MOTOREN/ DRIVES	KLEEMANN SERIES	K007		= 100	+
		EDITED	JBR		MOBICAT MC 120 Z EU					KLEEMANN MATERIAL NO	2315434		CAE-SYSTEM: EPLAN 5.70	PG. 13
MODIFICAT.	DATE	NAME	NORM	DIN	ORIGIN	REP.F.	REP.T.					PG. 41		

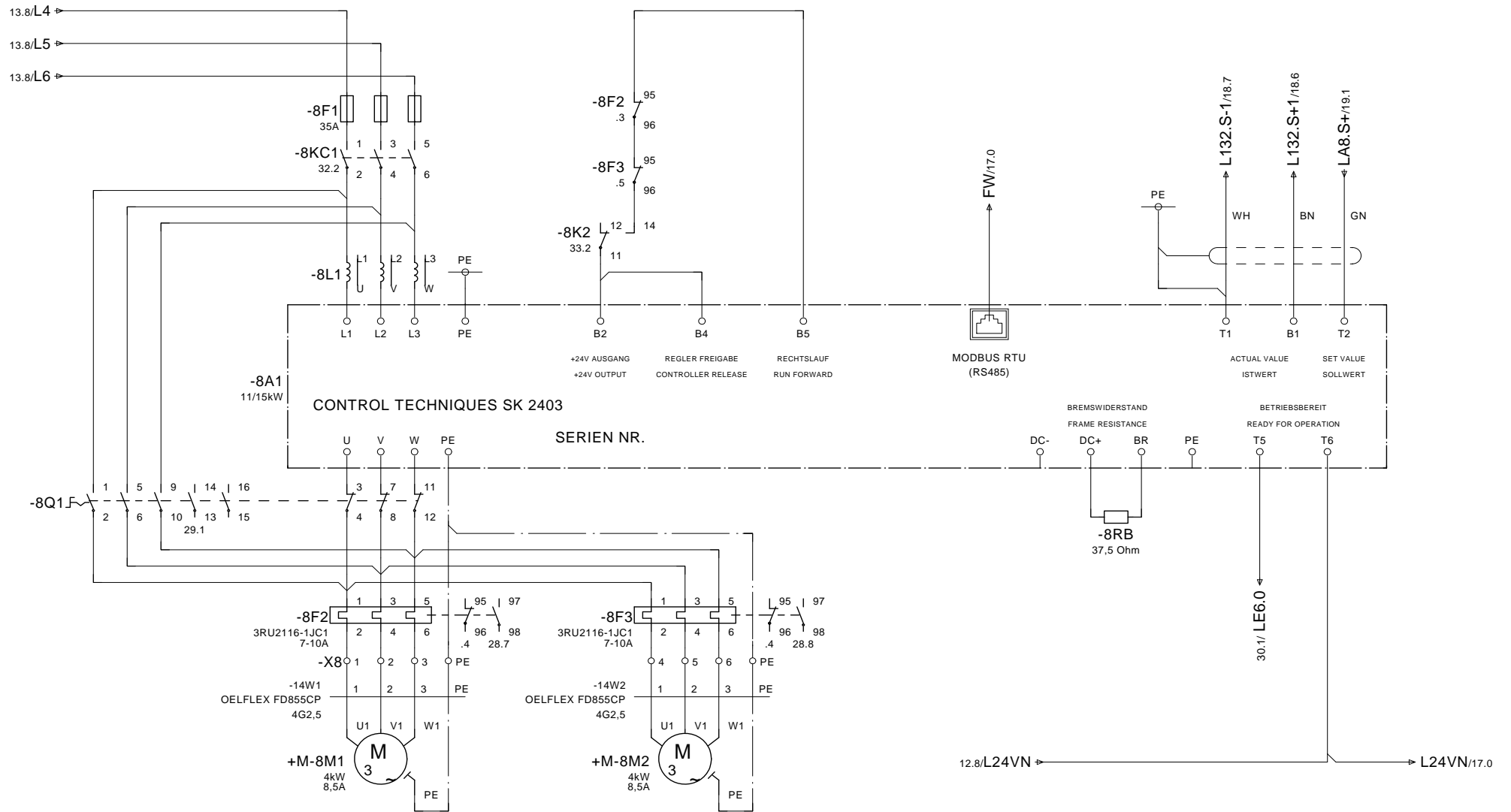

VIBRATING FEEDER 8  
DRIVE LEFT

VIBRATING FEEDER 8  
DRIVE RIGHT

AUFGABERINNE 8  
MOTOR LINKS

AUFGABERINNE 8  
MOTOR RECHTS

DATE	04.Dez.2015
EDITED	JBR
CONTR.	D. MALLKOWSKY

KLEEMANN GMBH
MOBICAT MC 120 Z EU



AUFGABERINNE 8 - POS. 2/  
VIBRATING FEEDER 8 - POS. 2

KLEEMANN  
SERIES K007

KLEEMANN  
MATERIAL NO 2315434

= 100

CAE-SYSTEM:  
EPLAN 5.70

+

PG. 14  
PG. 41

0	1	2	3	4	5	6	7	8	9
---	---	---	---	---	---	---	---	---	---

			DATE	04.Dez.2015	KLEEMANN GMBH			 	RESERVE/ SPARE	KLEEMANN SERIES	K007	= 100	+
		EDITED	JBR	MOBICAT MC 120 Z EU			KLEEMANN MATERIAL NO			2315434	CAE-SYSTEM: EPLAN 5.70	PG.	15
MODIFICAT.	DATE	NAME	NORM	DIN	ORIGIN	REP.F.	REP.T.					PG.	41

0	1	2	3	4	5	6	7	8	9
---	---	---	---	---	---	---	---	---	---

			DATE	04.Dez.2015	KLEEMANN GMBH			 	RESERVE/ SPARE	KLEEMANN SERIES	K007	= 100	+
			EDITED	JBR	MOBICAT MC 120 Z EU					KLEEMANN MATERIAL NO	2315434	CAE-SYSTEM: EPLAN 5.70	PG. 16
MODIFICAT.	DATE	NAME	NORM	DIN	ORIGIN	REP.F.	REP.T.						PG. 41



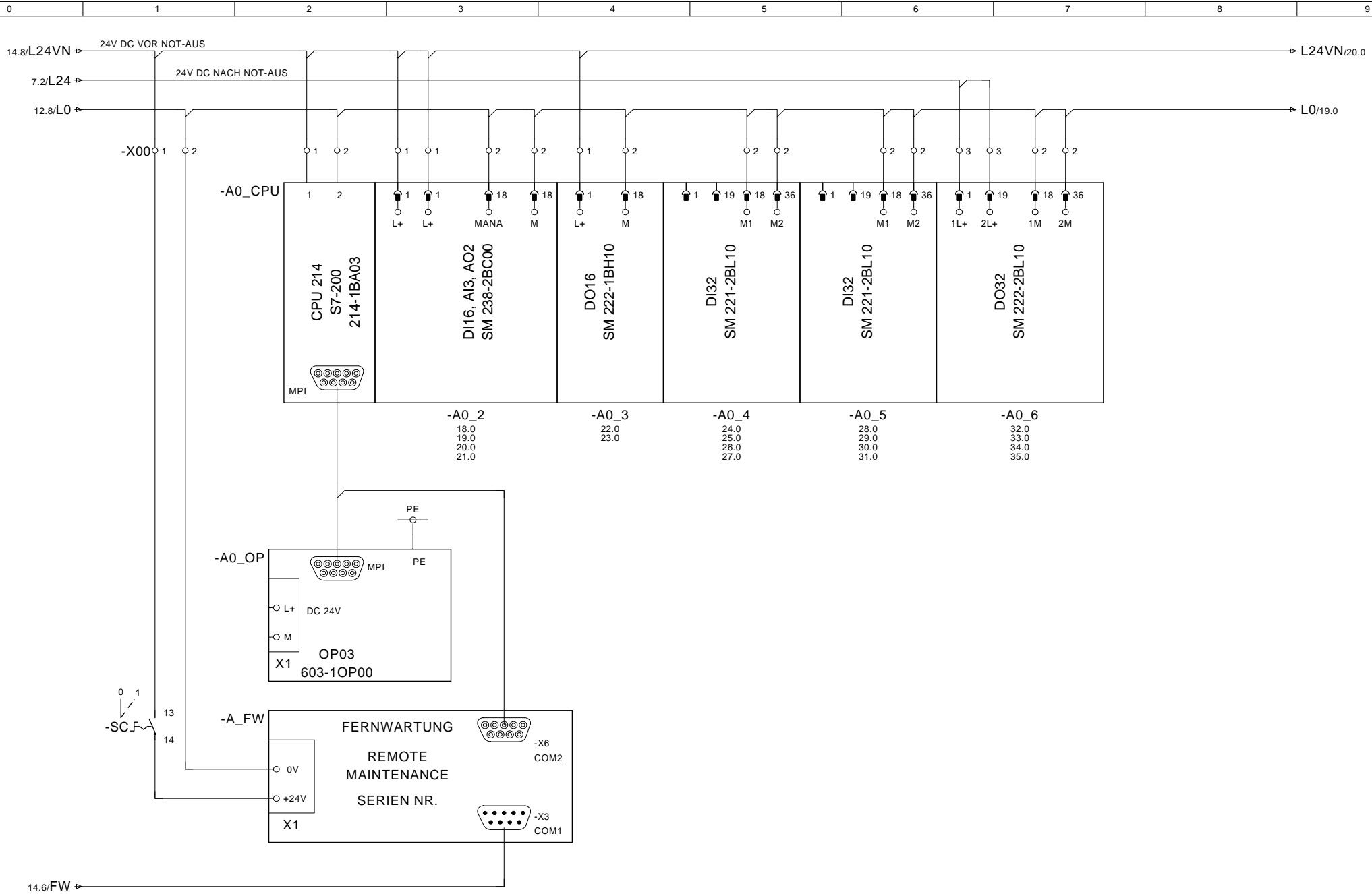

		DATE	04.Dez.2015	KLEEMANN GMBH		 	CPU STEUERUNG/ CPU CONTROL SYSTEM	KLEEMANN SERIES	K007	= 100	+	
		EDITED	JBR	MOBICAT MC 120 Z EU				KLEEMANN MATERIAL NO	2315434	CAE-SYSTEM: EPLAN 5.70	PG.	17
MODIFICAT.	DATE	NAME	NORM	DIN	ORIGIN	REP.F.	REP.T.				PG.	41

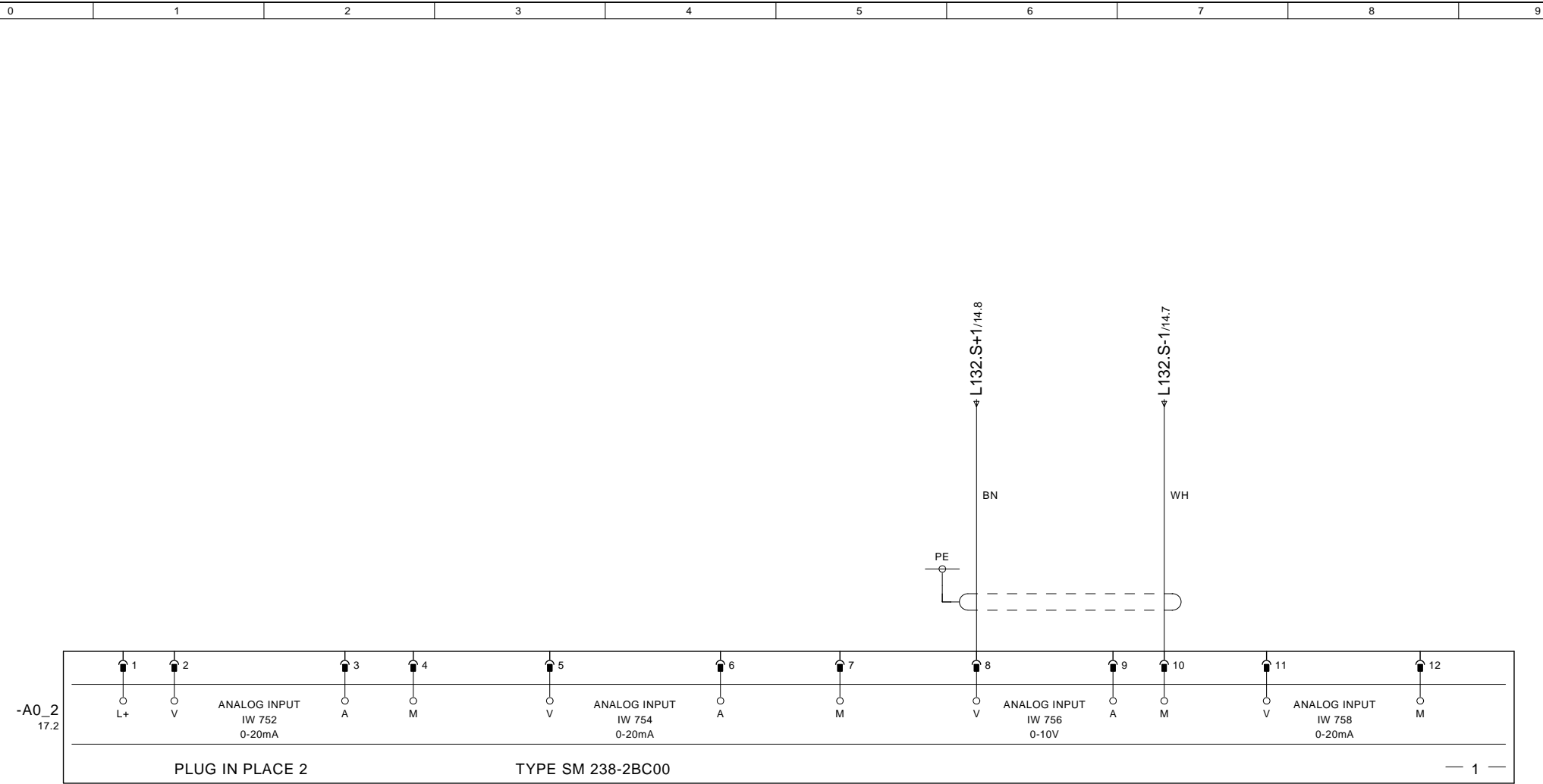

SPARE

SPARE

SPARE

SPARE

ACTUAL VALUE  
FREQUENCY CONVERTER  
VIBRATING FEEDER 8

SPARE

RESERVE

RESERVE

RESERVE

RESERVE

ISTWERT  
FREQUENZUMRICHTER  
AUFGABERINNE 8

RESERVE

— 1 —

			DATE	04.Dez.2015	KLEEMANN GMBH			 	ANALOG EINGÄNGE/ ANALOG INPUTS	KLEEMANN SERIES	K007	= 100	+	
			EDITED	JBR	MOBICAT MC 120 Z EU					KLEEMANN MATERIAL NO	2315434	CAE-SYSTEM: EPLAN 5.70	PG.	18
			CONTR.	D. MALLKOWSKY	ORIGIN	REP.F.	REP.T.						PG.	41

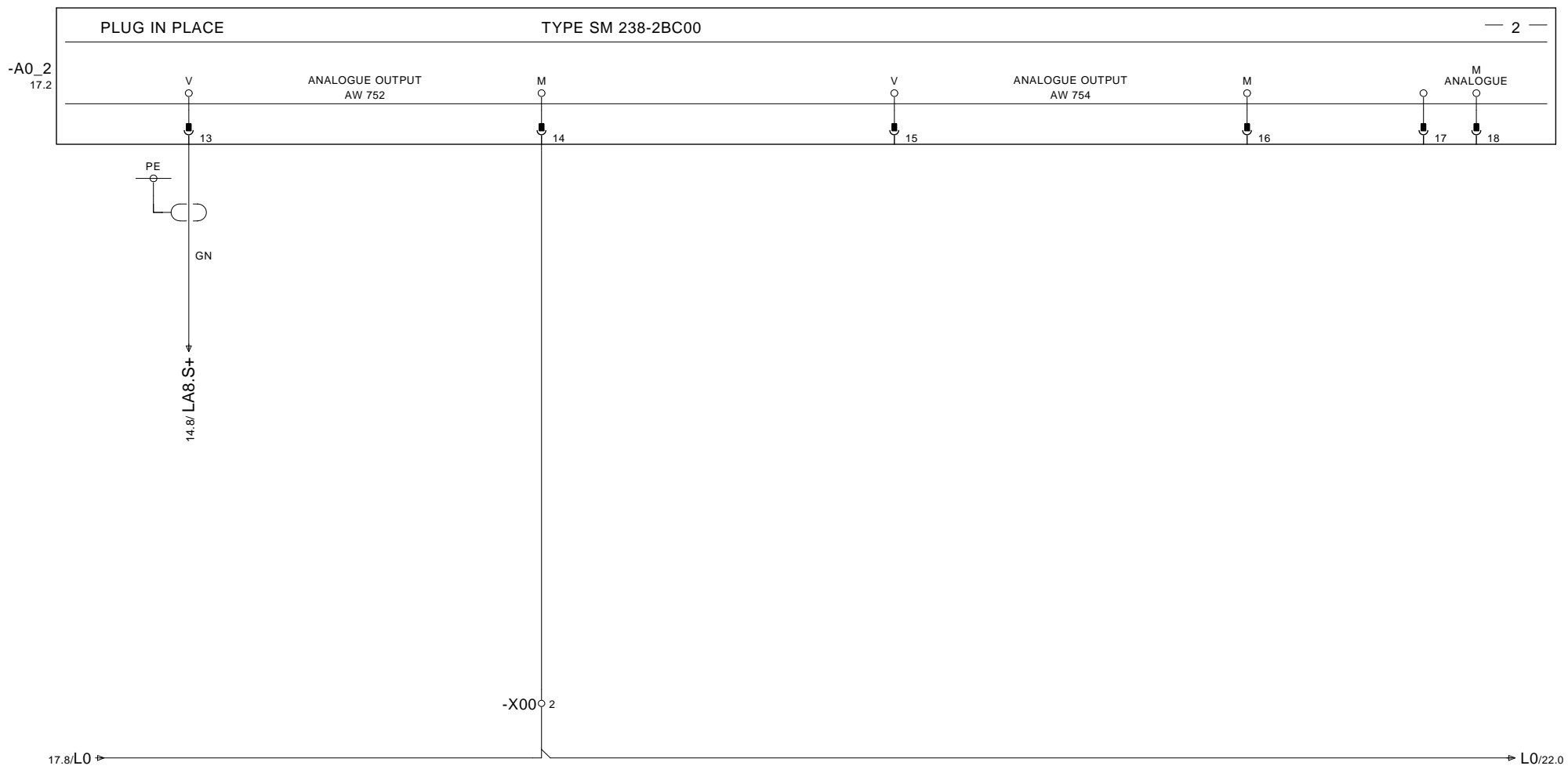

SET VALUE  
 FREQUENCY CONVERTER  
 VIBRATING FEEDER 8  
 SOLLWERT  
 FREQUENZUMRICHTER  
 AUFGABERINNE 8

SPARE  
 RESERVE

		DATE	04.Dez.2015		KLEEMANN GMBH			 	ANALOGUE AUSGAENGE/ ANALOG OUTPUTS		KLEEMANN SERIES	K007		= 100	+
		EDITED	JBR		MOBICAT MC 120 Z EU				KLEEMANN MATERIAL NO	2315434		CAE-SYSTEM:	EPLAN 5.70		PG. 19
MODIFICAT.	DATE	NAME	NORM	DIN	ORIGIN	REP.F.	REP.T.							PG. 41	

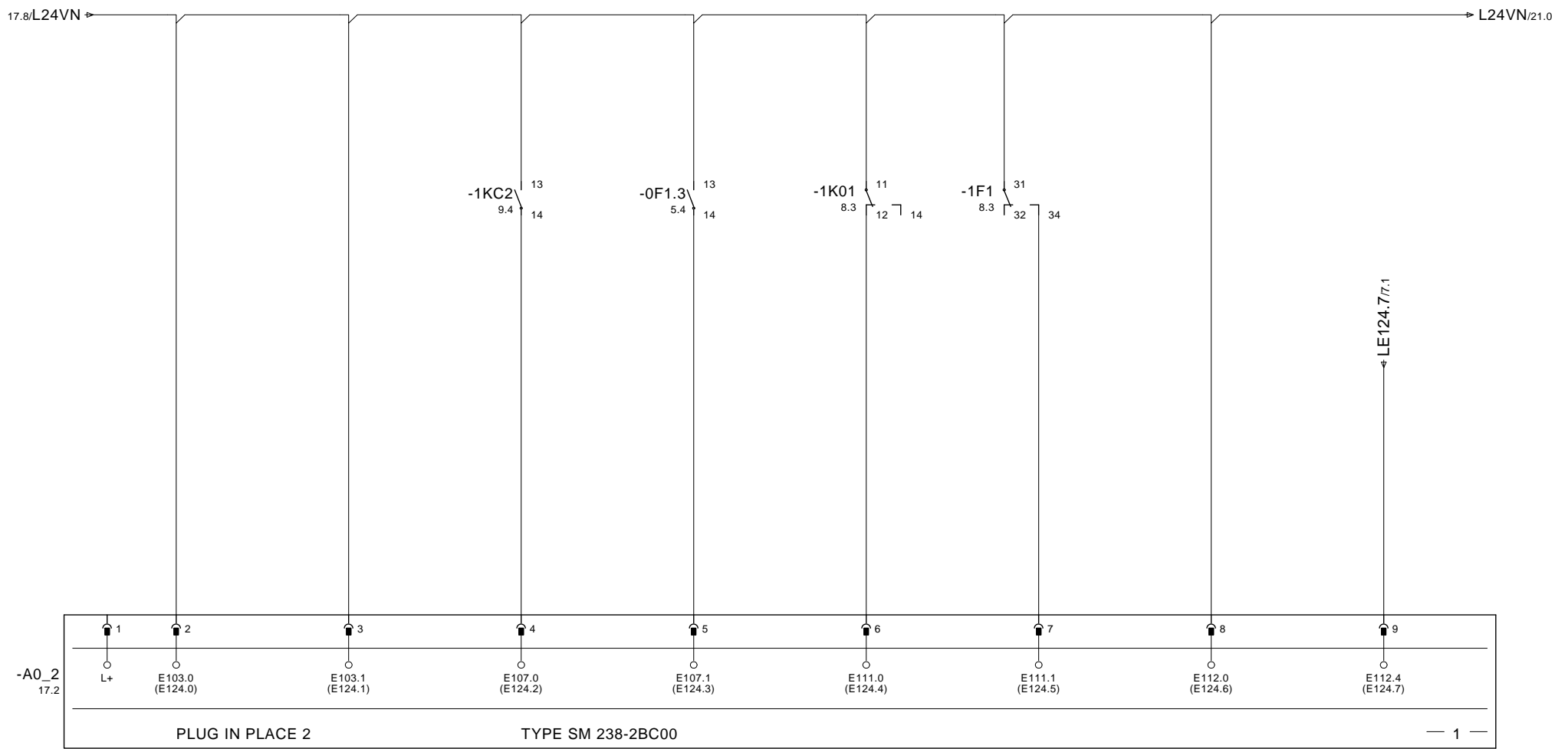

SPARE	SPARE	CRUSHER DELTA CONNECTED	MONITORING OF FUSE 230V	OVERLOAD CRUSHER	MOTOR CONTROLLING CRUSHER	SPARE	CONTROL VOLTAGE EXIST
RESERVE	RESERVE	BRECHER IM DREIECK	SICHERUNGS- UEBERWACHUNG 230V	BRECHERUEBERLAST	MOTORUEBERWACHUNG BRECHER	RESERVE	STEUERSPANNUNG VORHANDEN

DATE	04.Dez.2015	KLEEMANN GMBH		DIGITALE EINGAENGE/ DIGITAL INPUTS	KLEEMANN SERIES	K007	= 100	+	
EDITED	JBR				KLEEMANN MATERIAL NO	2315434	CAE-SYSTEM: EPLAN 5.70	PG.	20
CONTR.	D. MALLKOWSKY							MOBICAT MC 120 Z EU	PG.
MODIFICAT.	DATE	NAME	NORM	DIN	ORIGIN	REP.F.	REP.T.		

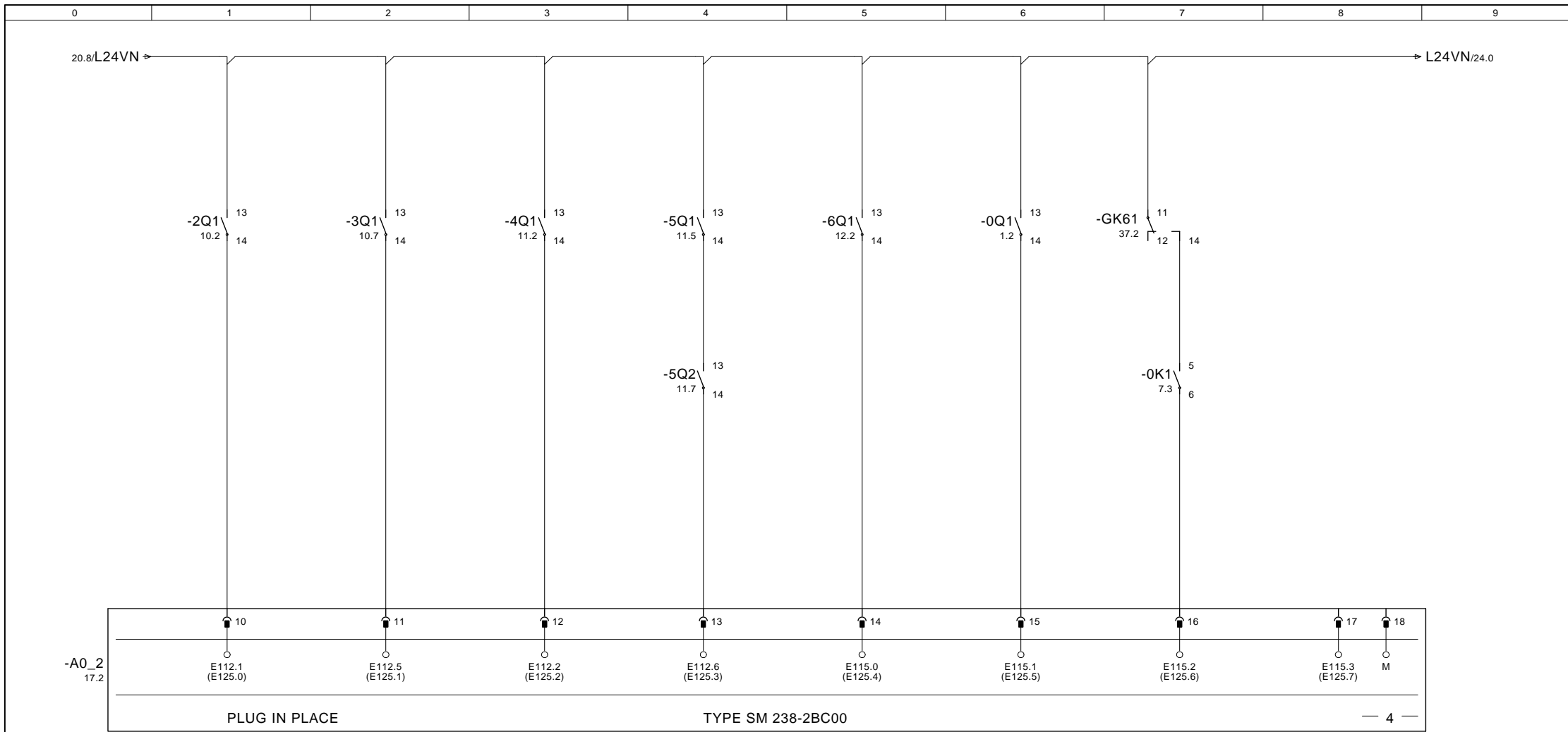

MONITORING MOTOR PROTECTION SWITCH  
UEBERWACHUNG MOTORSCHUTZSCHALTER

MAGNETIC BELT 2	CONVEYOR BELT 3	CONVEYOR BELT 4	SHAKING CONVEYOR 5	CONVEYOR BELT 6	MAIN SWITCH ON	DIESELMOTOR RUNNING	SPARE
MAGNETBAND 2	FOERDERBAND 3	FOERDERBAND 4	FOERDERRINNE 5	FOERDERBAND 6	HAUPTSCHALTER EIN	DIESELMOTOR LAEUFT	RESERVE

DATE	04.Dez.2015	KLEEMANN GMBH	 	DIGITALE EINGAENGE/ DIGITAL INPUTS	KLEEMANN SERIES	K007	= 100	+		
EDITED	JBR				KLEEMANN MATERIAL NO	2315434	CAE-SYSTEM:	EPLAN 5.70	PG.	21
CONTR.	D. MALLKOWSKY						MOBICAT MC 120 Z EU	REP.T.	PG.	41
MODIFICAT.	DATE	NAME	NORM	DIN	ORIGIN	REP.F.	REP.T.			

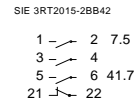
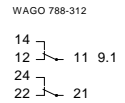
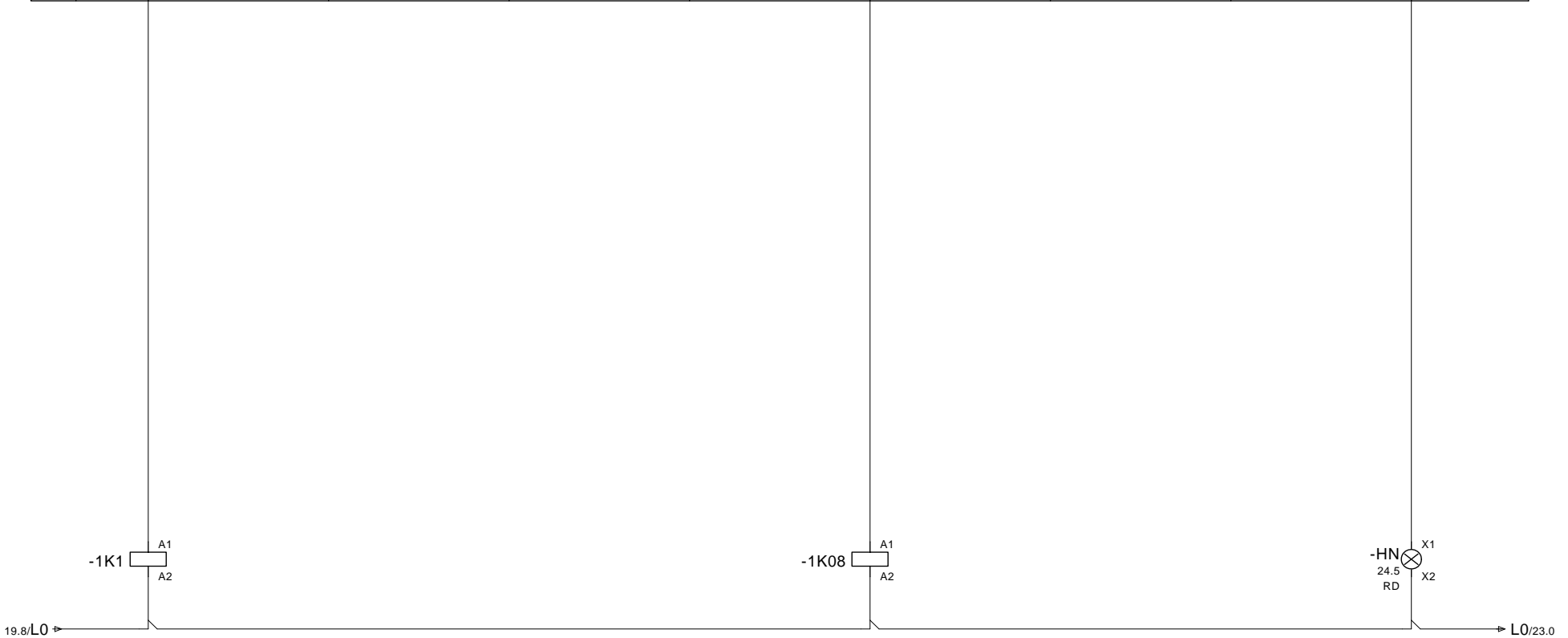
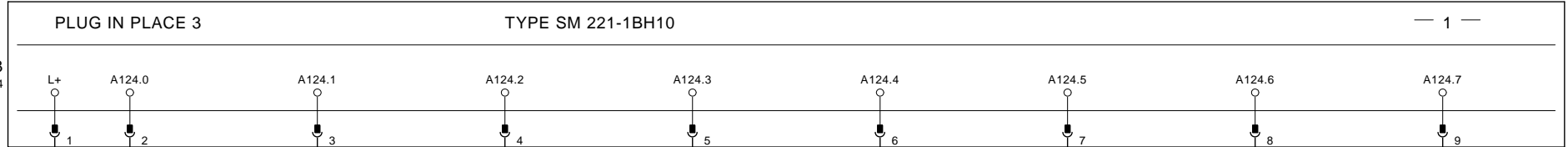

RELEASING CRUSHER	SPARE	SPARE	SPARE	CONTACTOR COUPLING ON	SPARE	SPARE	EMERGENCY STOP
FREIGABE BRECHER	RESERVE	RESERVE	RESERVE	SCHUETZ FAHRKUPPLUNG	RESERVE	RESERVE	NOT-AUS

DATE	04.Dez.2015	KLEEMANN GMBH	 	DIGITALE AUSGAENGE A 124.0 - A 124.7/ DIGITAL OUTPUTS A 124.0 - A 124.7	KLEEMANN SERIES	K007	= 100	+
EDITED	JBR				KLEEMANN MATERIAL NO	2315434	CAE-SYSTEM:	EPLAN 5.70
CONTR.	D. MALLKOWSKY	MOBICAT MC 120 Z EU	REP.T.					PG.
MODIFICAT.	DATE	NAME	NORM	DIN	ORIGIN	REP.F.	REP.T.	

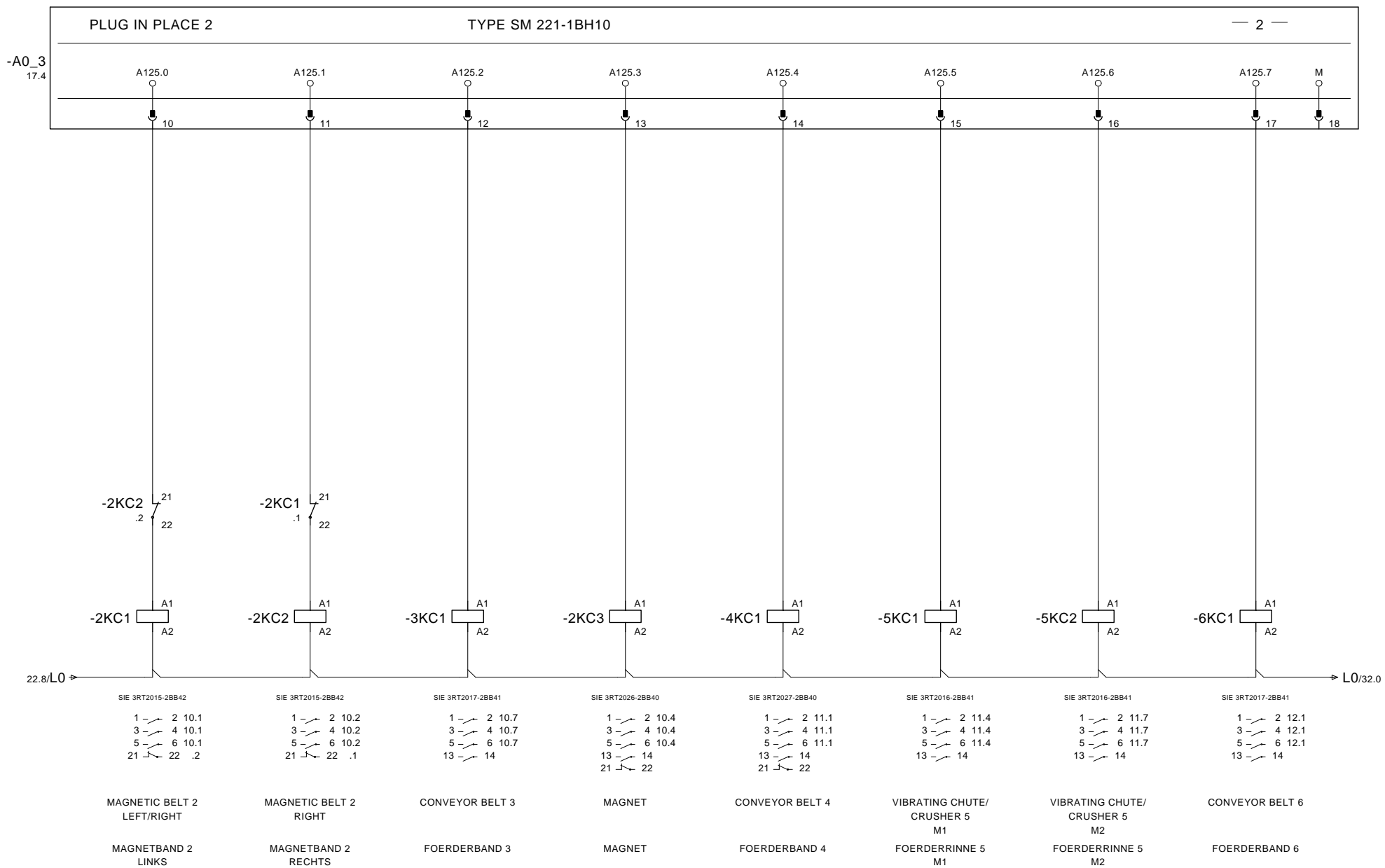

DATE		04.Dez.2015		KLEEMANN GMBH		 		DIGITALE AUSGAENGE		KLEEMANN SERIES		K007		= 100		+	
EDITED		JBR		MOBICAT MC 120 Z EU				A 125.0 - A 125.7/		KLEEMANN MATERIAL NO		2315434		CAE-SYSTEM: EPLAN 5.70		PG. 23	
CONTR.		D. MALLKOWSKY						DIGITAL OUTPUTS A 125.0 - A 125.7								PG. 41	
MODIFICAT.	DATE	NAME	NORM	DIN	ORIGIN	REP.F.	REP.T.										

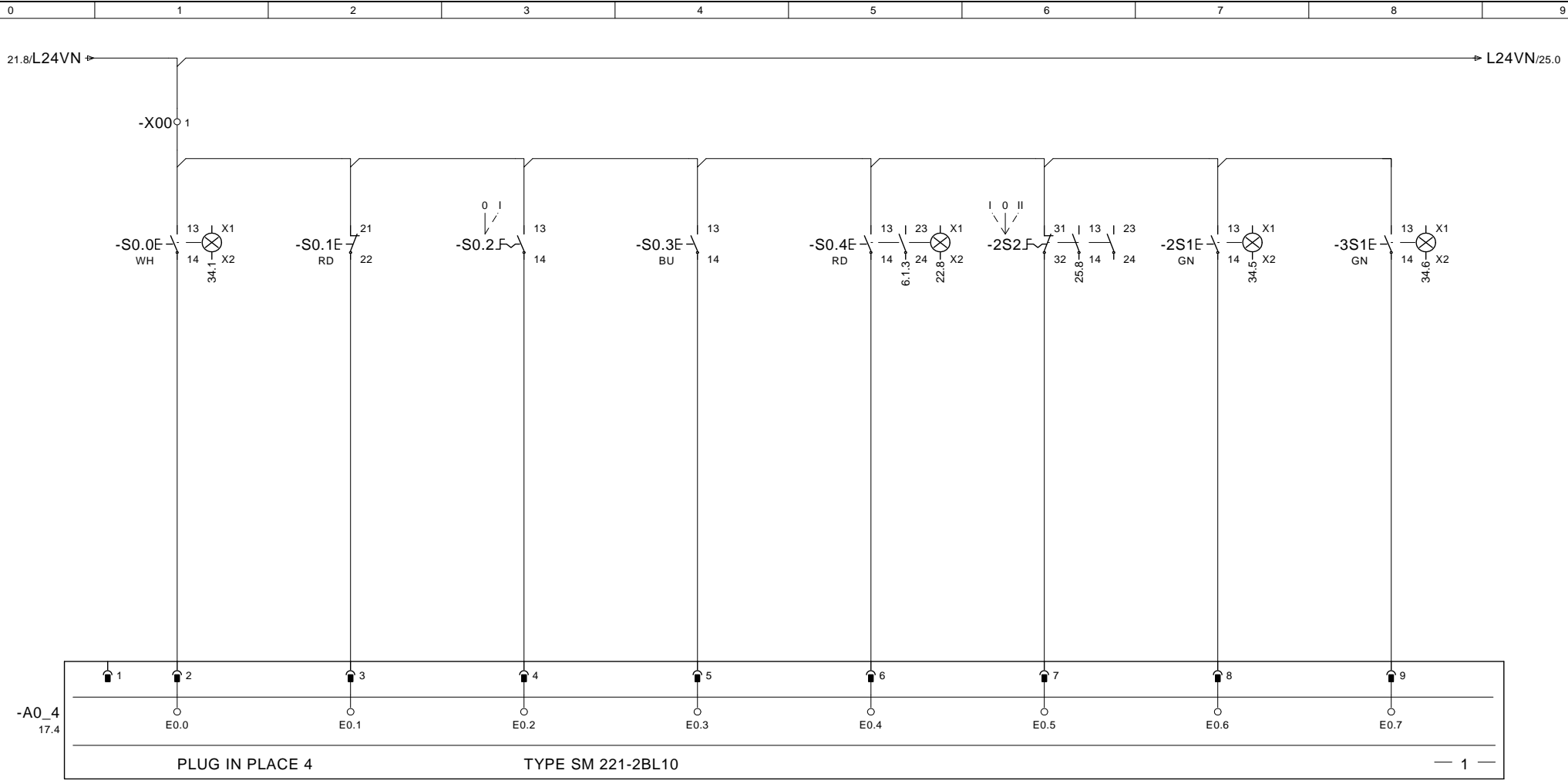

INSTALLATION ON

INSTALLATION OFF

AUTO/MANUAL

LAMP TEST

EMERGENCY STOP  
RESET

MAGNETIC BELT 2  
LEFT

MAGNETIC BELT 2  
ON/OFF

CONVEYOR BELT 3  
ON/OFF

ANLAGE EIN

ANLAGE AUS

AUTO/HAND

LAMPENTEST

NOT-AUS  
STOERUNG  
QUITTIEREN

MAGNETBAND 2  
LINKS

MAGNETBAND 2  
EIN/AUS

FOERDERBAND 3  
EIN/AUS

DATE	04.Dez.2015
EDITED	JBR
CONTR.	D. MALLKOWSKY
NORM	DIN

KLEEMANN GMBH  
MOBICAT MC 120 Z EU



DIGITALE EINGAENGE E 0.0 - E 0.7/  
DIGITAL INPUTS E 0.0 - E 0.7

KLEEMANN  
SERIES  
KLEEMANN  
MATERIAL NO

K007

2315434

= 100

CAE-SYSTEM:  
EPLAN 5.70

+

PG. 24  
PG. 41



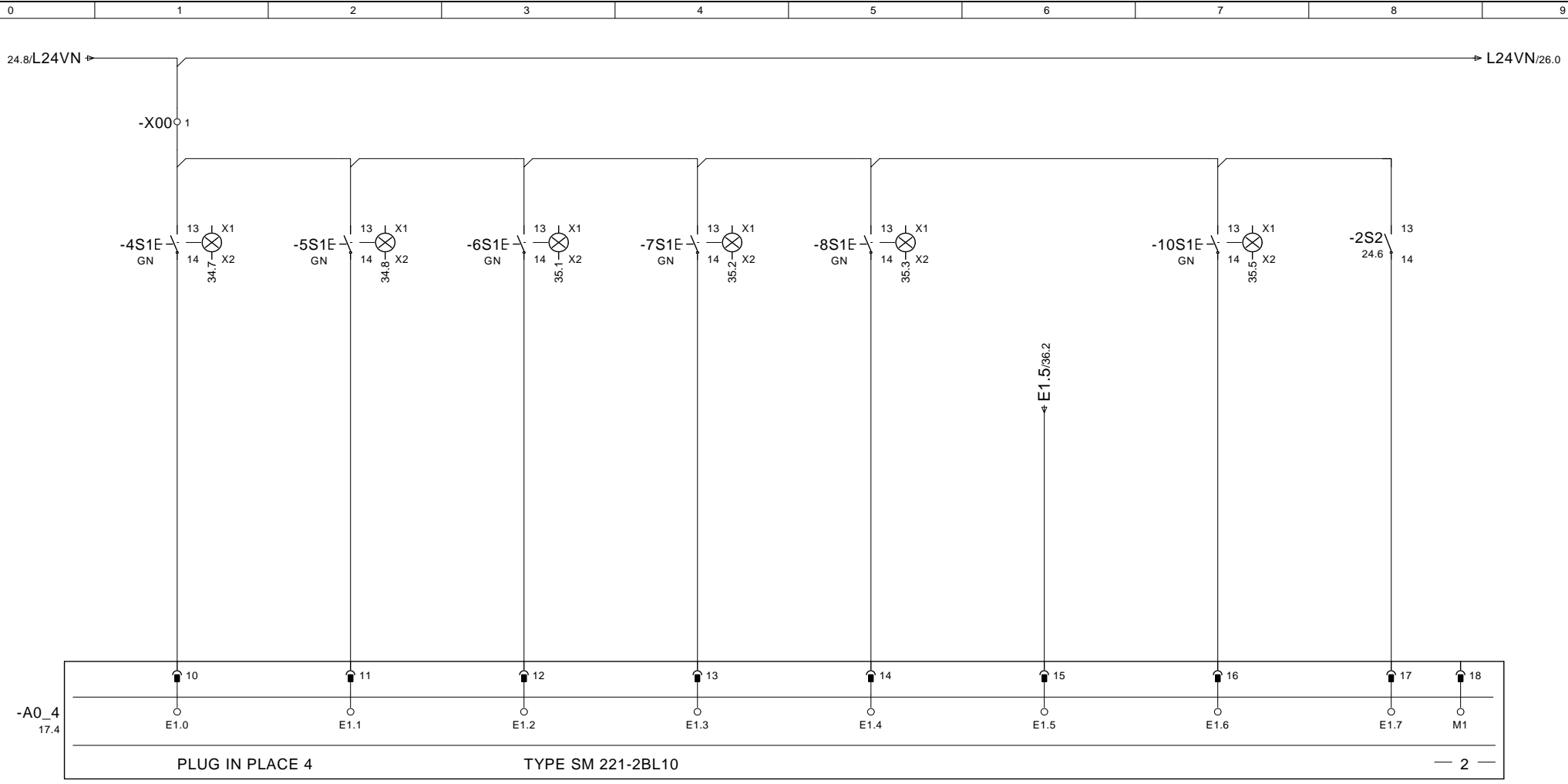

CONVEYOR BELT 4 ON/OFF	VIBRATING CHUTE/ CRUSHER 5 ON/OFF	CONVEYOR BELT 6 ON/OFF	VIBRATING SCREEN 7 ON/OFF	VIBRATING FEEDER 8 ON/OFF	LIGHT BARRIER	WATERPUMP 10 ON/OFF	MAGNETIC BELT 2 RIGHT
FOERDERBAND 4 EIN/AUS	FOERDERRINNE 5 EIN/AUS	FOERDERBAND 6 EIN/AUS	VIBRATIONSSIEB 7 EIN/AUS	AUFGABERINNE 8 EIN/AUS	LICHTSCHRANKE	WASSERPUMPE 10 EIN/AUS	MAGNETBAND 2 RECHTS

DATE	04.Dez.2015	KLEEMANN GMBH		 	DIGITALE EINGAENGE E 1.0 - E 1.7/ DIGITAL INPUTS E 1.0 - E 1.7	KLEEMANN SERIES	K007	= 100	+
EDITED	JBR	MOBICAT MC 120 Z EU			KLEEMANN MATERIAL NO	2315434	CAE-SYSTEM: EPLAN 5.70	PG.	25
CONTR.	D. MALLKOWSKY	ORIGIN	REP.F.	REP.T.			PG.	41	

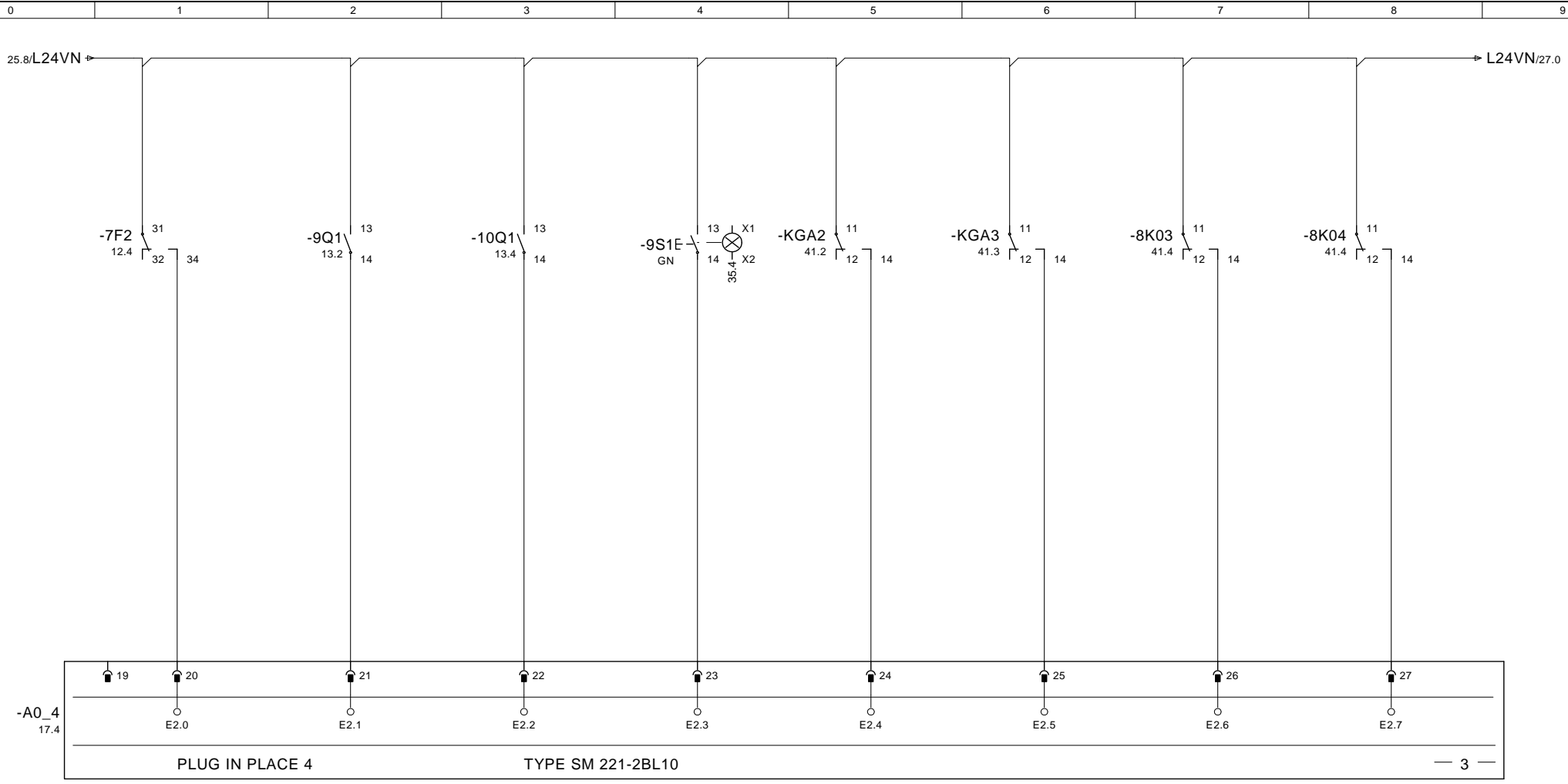

MOTOR CONTROLLING VIBRATING SCREEN 7	MOTOR PROTECTION HYDRAULIC	MOTOR PROTECTION WATERPUMP	HYDRAULIC	VIBRATING CHUTE +SCREEN ON (REMOTE)	VIBRATING CHUTE +SCREEN OFF (REMOTE)	VIBRATING CHUTE SLOWER (RADIO)	VIBRATING CHUTE FASTER (RADIO)
MOTORUEBERWACHUNG VIBRATIONSSIEB 7	MOTORSCHUTZ HYDRAULIK	MOTORSCHUTZ WASSERPUMPE	HYDRAULIK	RINNE+SIEB EIN (FUNK)	RINNE+SIEB AUS (FUNK)	RINNE LANGSAMER (FUNK)	RINNE SCHNELLER (FUNK)

DATE	04.Dez.2015	KLEEMANN GMBH		 	DIGITAL EINGAENGE E 2.0 - E 2.7/ DIGITAL INPUTS E 2.0 - E 2.7	KLEEMANN SERIES	K007	= 100	+
EDITED	JBR	MOBICAT MC 120 Z EU			KLEEMANN MATERIAL NO	2315434	CAE-SYSTEM: EPLAN 5.70	PG.	26
CONTR.	D. MALLKOWSKY	ORIGIN	REP.F.	REP.T.				PG.	41

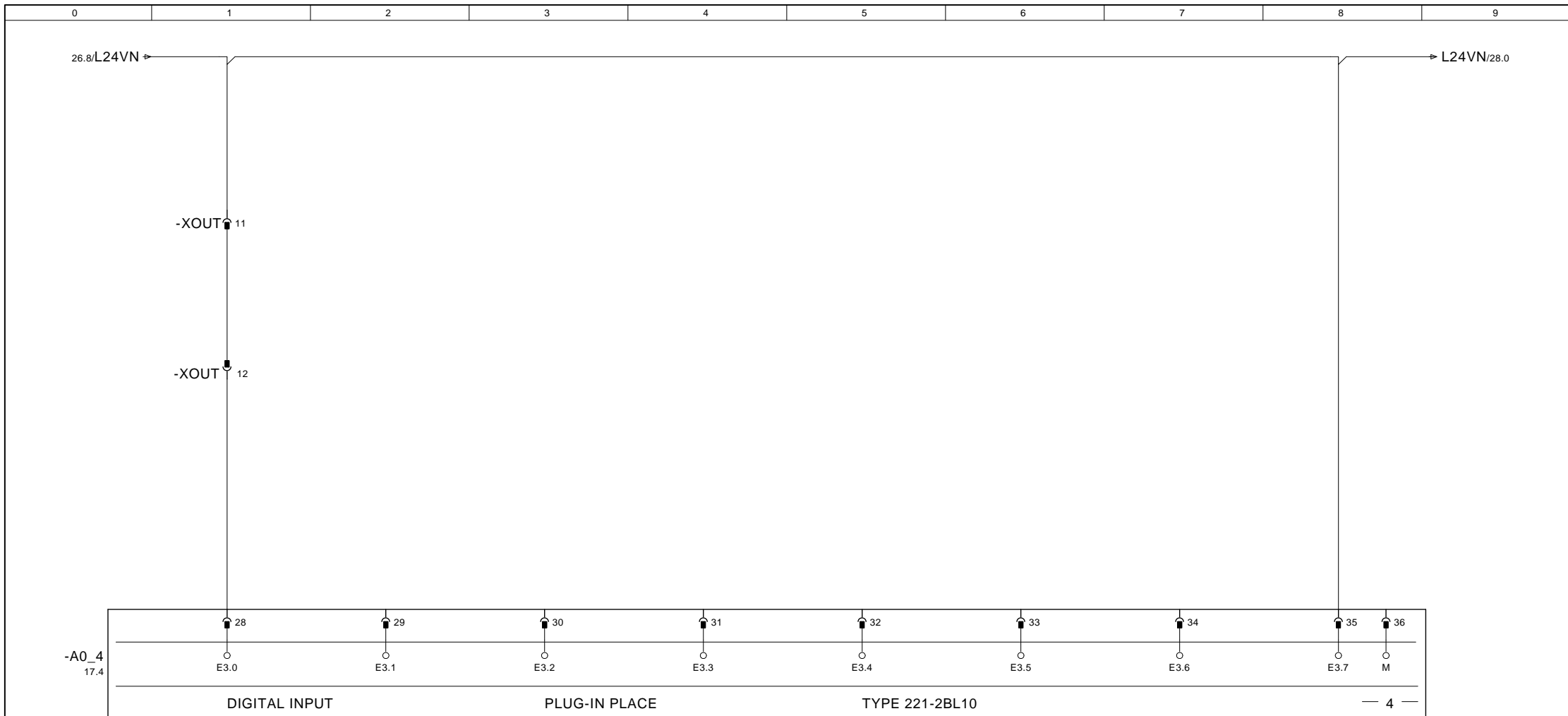

LOCKING  
CONVEYOR BELT 2

SPARE

SPARE

SPARE

SPARE

SPARE

SPARE

SPARE

VERRIEGELUNG  
FOERDERBAND 2

RESERVE

RESERVE

RESERVE

RESERVE

RESERVE

RESERVE

RESERVE

			DATE	04.Dez.2015	KLEEMANN GMBH			 	DIGITAL EINGAENGE E 3.0 - E 3.7/ DIGITAL INPUTS E 3.0 - E 3.7	KLEEMANN SERIES	K007	= 100	+
			EDITED	JBR	MOBICAT MC 120 Z EU					KLEEMANN MATERIAL NO	2315434	CAE-SYSTEM: EPLAN 5.70	PG. 27
MODIFICAT.	DATE	NAME	NORM	DIN	ORIGIN	REP.F.	REP.T.					PG. 41	

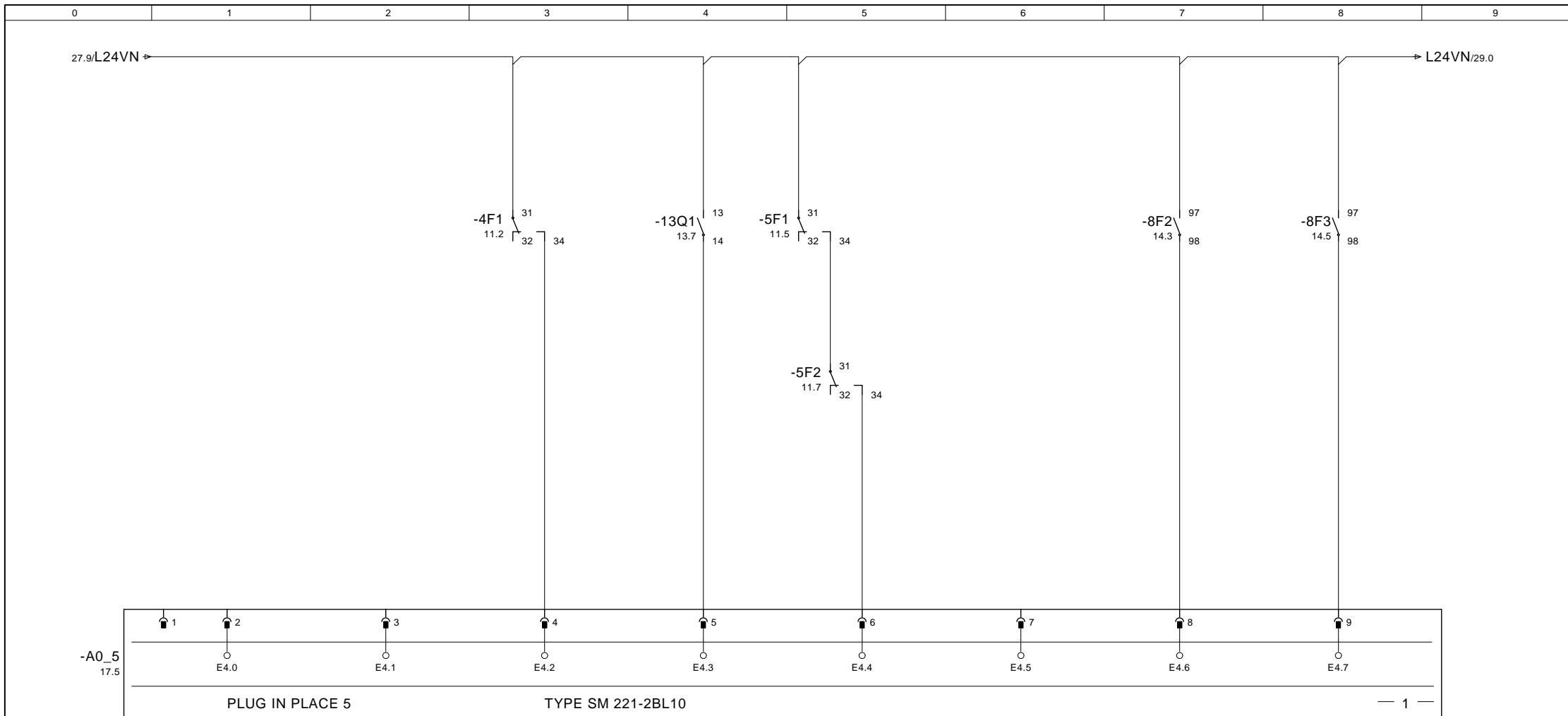

SPARE	SPARE	MOTOR CONTROLLING CONVEYOR BELT 4	MOTOR PROTECTION PRESSURE BURDEN	MOTOR CONTROLLING VIBRATING CHUTE 5	SPARE	MOTOR PROTECTION VIBRATING FEEDER 8	MOTOR PROTECTION VIBRATING FEEDER 8
RESERVE	RESERVE	MOTORUEBERWACHUNG FOERDERBAND 4	MOTORSCHUTZ UEBERDRUCK	MOTORUEBERWACHUNG FOERDERRINNE 5	RESERVE	MOTORSCHUTZ AUFGABERINNE 8	MOTORSCHUTZ AUFGABERINNE 8

DATE	04.Dez.2015	KLEEMANN GMBH		 	DIGITAL EINGAENGE E 4.0 - E 4.7/ DIGITAL INPUTS E 4.0 - E 4.7	KLEEMANN SERIES	K007	= 100	+
EDITED	JBR	MOBICAT MC 120 Z EU			KLEEMANN MATERIAL NO	2315434	CAE-SYSTEM: EPLAN 5.70	PG.	28
CONTR.	D. MALLKOWSKY	ORIGIN	REP.F.	REP.T.			PG.	41	

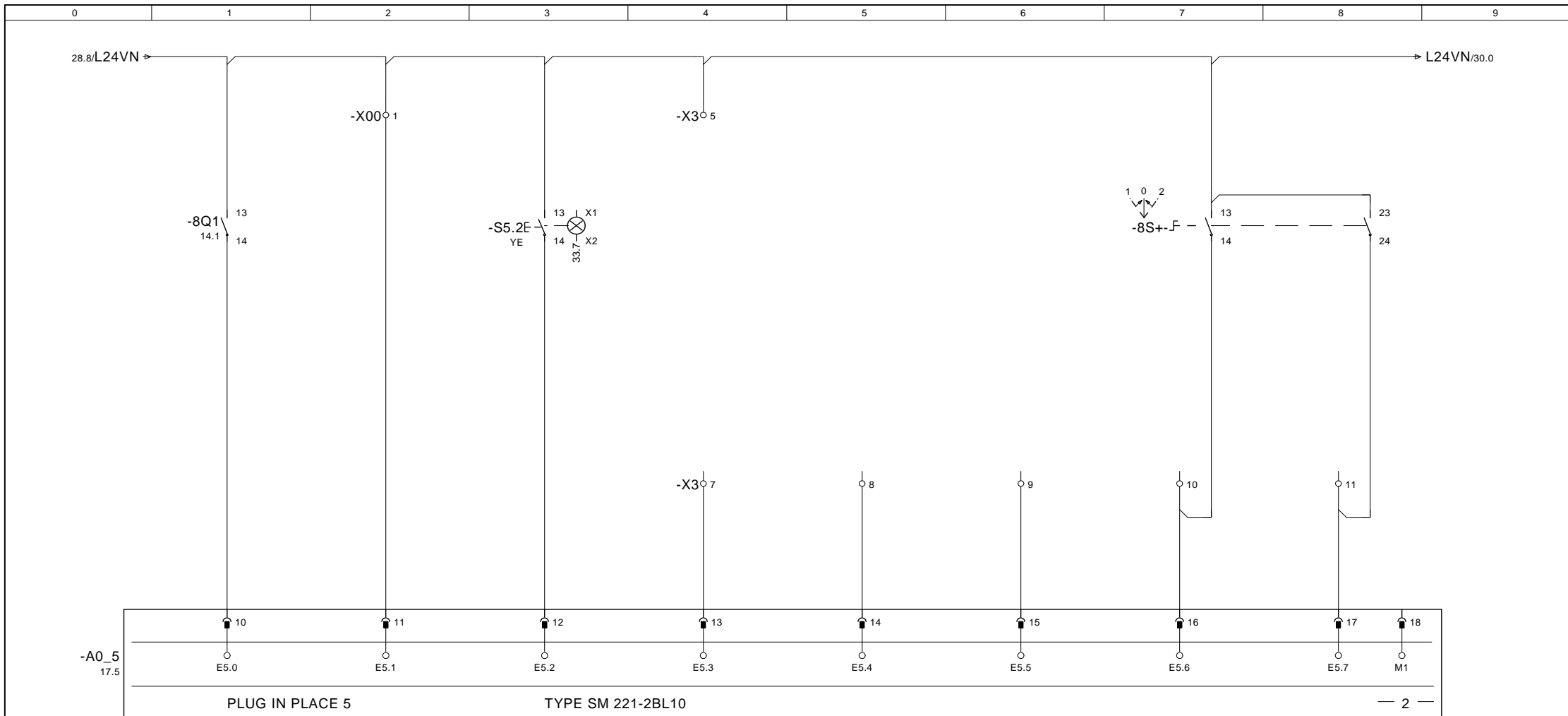

VIBRATING FEEDER FREQUENCY CONVERTER/ MAIN	SPARE	COUPLING ON/OFF	SPARE	SPARE	SPARE	VIBRATING FEEDER 8 +	VIBRATING FEEDER 8 -
AUFGABERINNE FU/NETZ	RESERVE	KUPPLUNG EIN/AUS	RESERVE	RESERVE	RESERVE	AUFGABERINNE 8 +	AUFGABERINNE 8 -

DATE	04.Dez.2015	KLEEMANN GMBH		 	DIGITALE EINGAENGE E 5.0 - E 5.7/ DIGITAL INPUTS E 5.0 - E 5.7	KLEEMANN SERIES	K007	= 100	+
EDITED	JBR	MOBICAT MC 120 Z EU				KLEEMANN MATERIAL NO	2315434	CAE-SYSTEM: EPLAN 5.70	PG.
CONTR.	D. MALLKOWSKY	ORIGIN	REP.F.	REP.T.				PG.	41

29.8/L24VN → L24VN/31.0

LE6.0/14.8

LE6.5/6.9

LE6.6/6.9

-A0\_5  
17.5

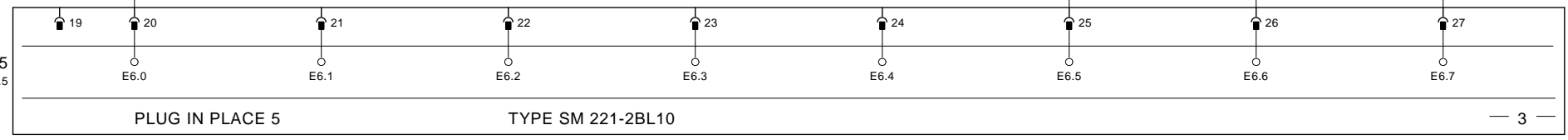

MALFUNCTION FREQUENCY CONVERTER VIBRATING FEEDER 8 STOERUNG FU AUFGABERINNE 8	SPARE	SPARE	SPARE	SPARE	OPERATION	CONVEYOR BELT	SPARE (FLOW GUARD)
	RESERVE	RESERVE	RESERVE	RESERVE	BETRIEB	TRANSPORT	RESERVE (STROEMUNGSWAECHTER)

DATE	04.Dez.2015	KLEEMANN GMBH		 	DIGITALE AUSGAENGE A 6.0 - A 6.7/ DIGITAL OUTPUTS A 6.0 - A 6.7	KLEEMANN SERIES	K007	= 100	+
EDITED	JBR	MOBICAT MC 120 Z EU			KLEEMANN MATERIAL NO	2315434	CAE-SYSTEM: EPLAN 5.70	PG.	30
CONTR.	D. MALLKOWSKY	ORIGIN	REP.F.	REP.T.				PG.	41

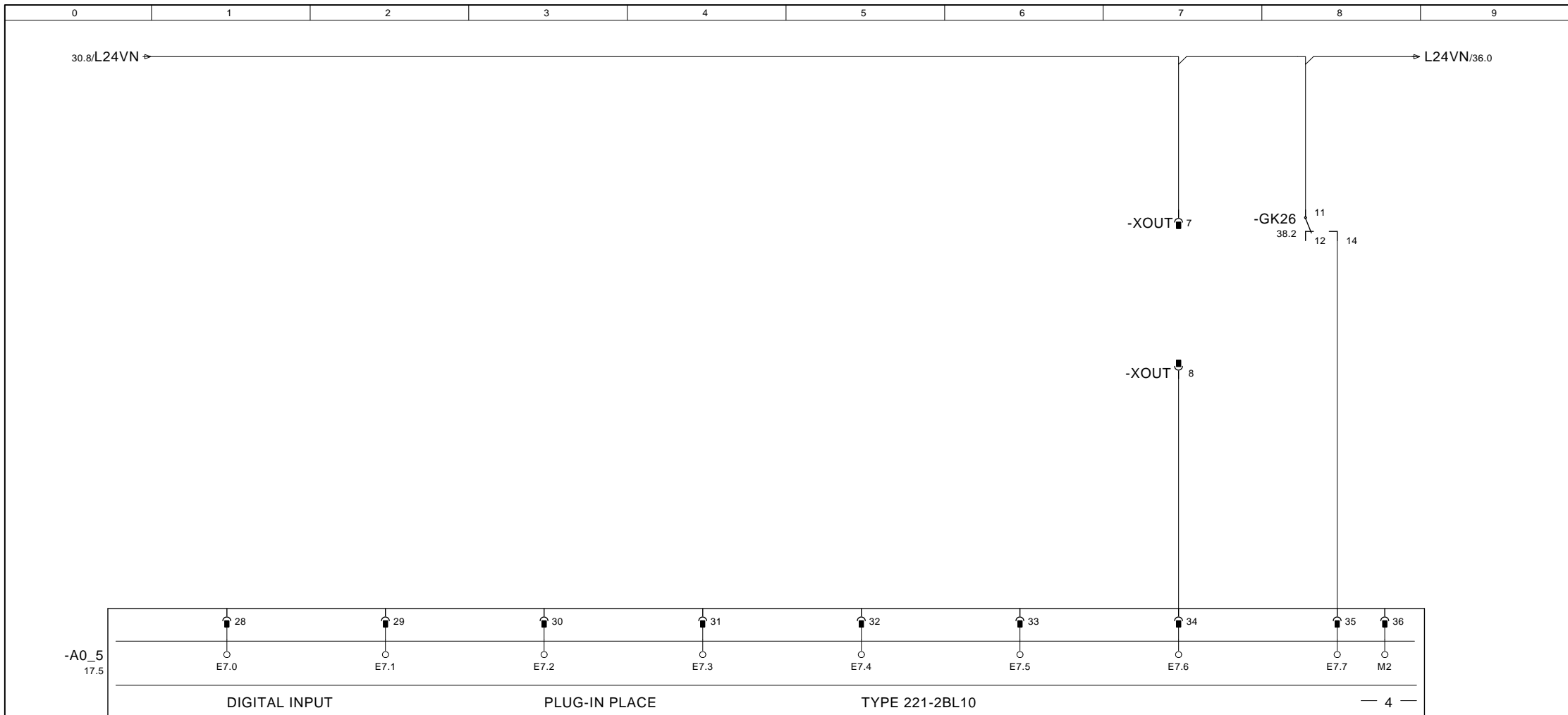

SPARE

SPARE

SPARE

SPARE

SPARE

SPARE

OVERLOAD  
REMOVAL

PREWARNING  
OIL TEMPERATUR

RESERVE

RESERVE

RESERVE

RESERVE

RESERVE

RESERVE

UEBERLAST  
ABFOERDERUNG

VORWARNUNG  
OELTEMPERATUR

			DATE	04.Dez.2015	KLEEMANN GMBH			 	DIGITALE AUSGAENGE A 7.0 - A 7.7/ DIGITAL OUTPUTS A 7.0 - A 7.7	KLEEMANN SERIES	K007	= 100	+
			EDITED	JBR	MOBICAT MC 120 Z EU					KLEEMANN MATERIAL NO	2315434	CAE-SYSTEM: EPLAN 5.70	PG. 31
MODIFICAT.	DATE	NAME	NORM	DIN	ORIGIN	REP.F.	REP.T.						PG. 41

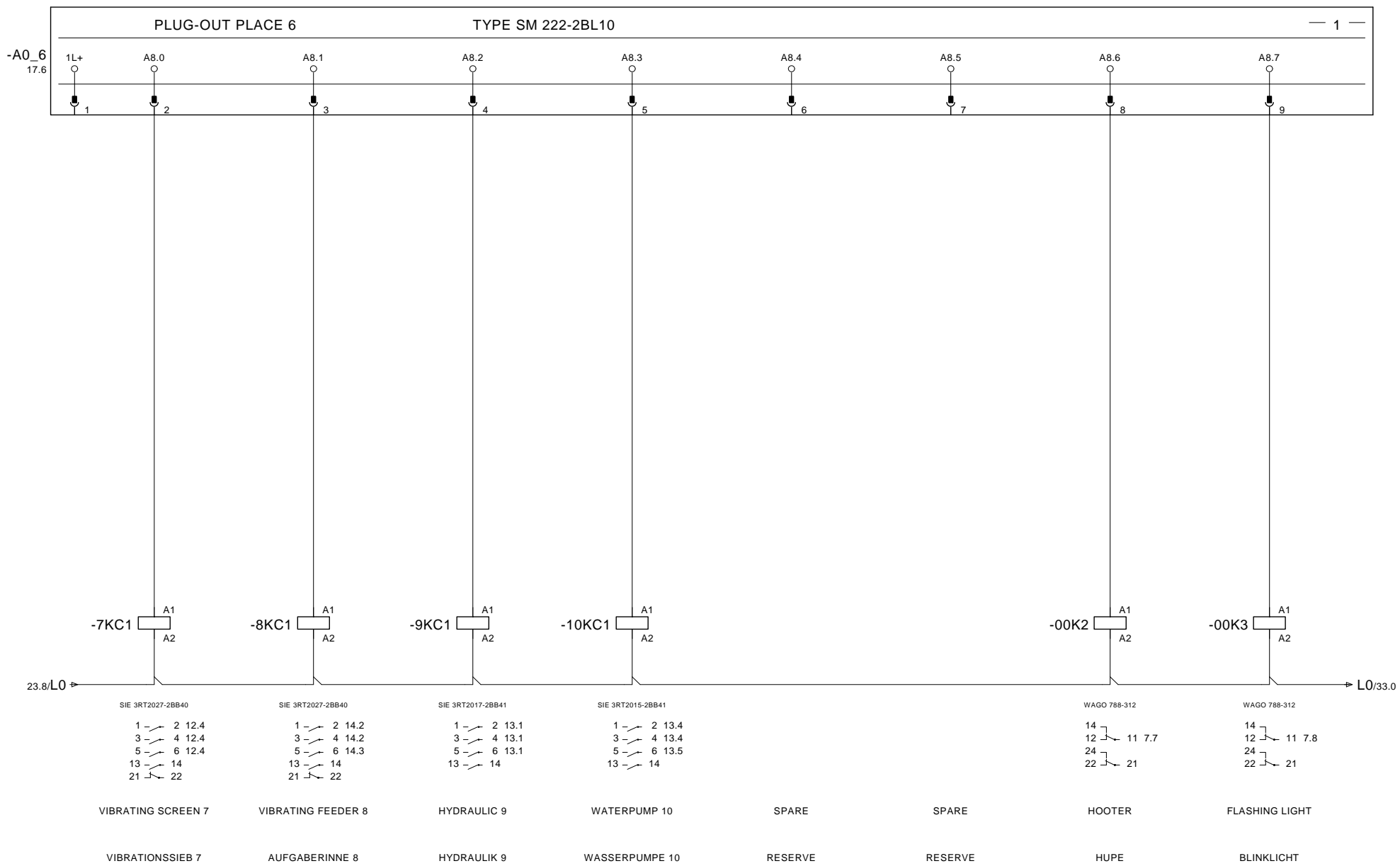

DATE 04.Dez.2015		KLEEMANN GMBH		 	DIGITALE EINGAENGE E 8.0 - E 8.7/ DIGITAL INPUTS E 8.0 - E 8.7	KLEEMANN SERIES <b>K007</b>		= 100	+
EDITED JBR		MOBICAT MC 120 Z EU				KLEEMANN MATERIAL NO <b>2315434</b>		CAE-SYSTEM: EPLAN 5.70	PG. 32
CONTR. D. MALLKOWSKY	ORIGIN	REP.F.	REP.T.	KLEEMANN MATERIAL NO <b>2315434</b>		CAE-SYSTEM: EPLAN 5.70	PG. 41		



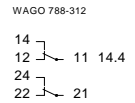
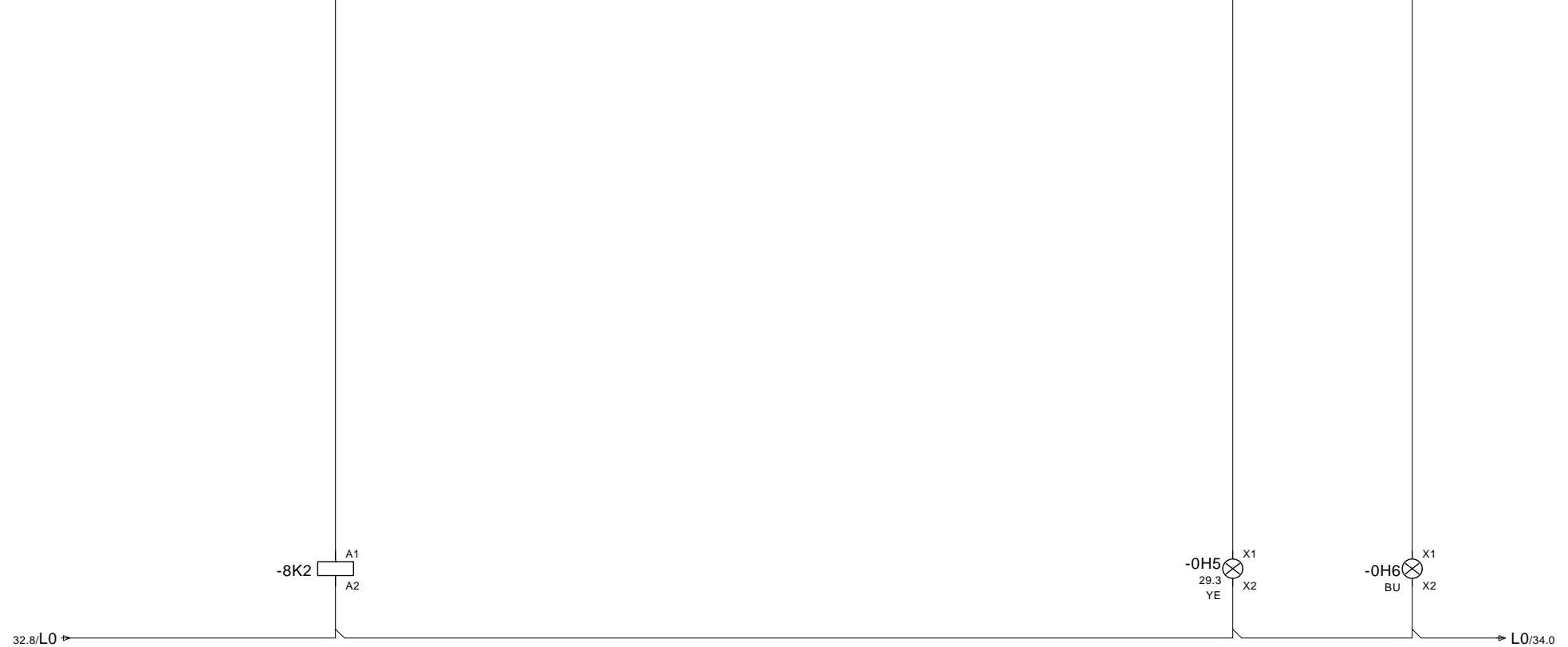
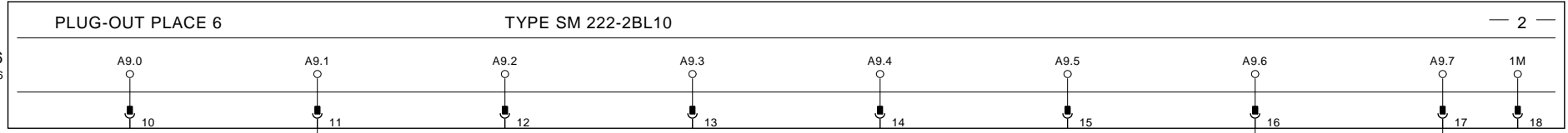

SPARE	START (RELEASING) FREQU. CONV. VIBRATING FEEDER 8	SPARE	SPARE	SPARE	SPARE	COUPLING ENGAGED	START-UP RELEASE
RESERVE	START (FREIGABE) FU AUFGABERINNE 8	RESERVE	RESERVE	RESERVE	RESERVE	KUPPLUNG EINGERUECKT	ANLAUFFREIGABE

DATE	04.Dez.2015	KLEEMANN GMBH			DIGITALE EINGAENGE E 9.0 - E 9.7/ DIGITAL INPUTS E 9.0 - E 9.7	KLEEMANN SERIES	K007	= 100	+
EDITED	JBR	MOBICAT MC 120 Z EU				KLEEMANN MATERIAL NO	2315434	CAE-SYSTEM: EPLAN 5.70	PG.
CONTR.	D. MALLKOWSKY	ORIGIN	REP.F.	REP.T.				PG.	41

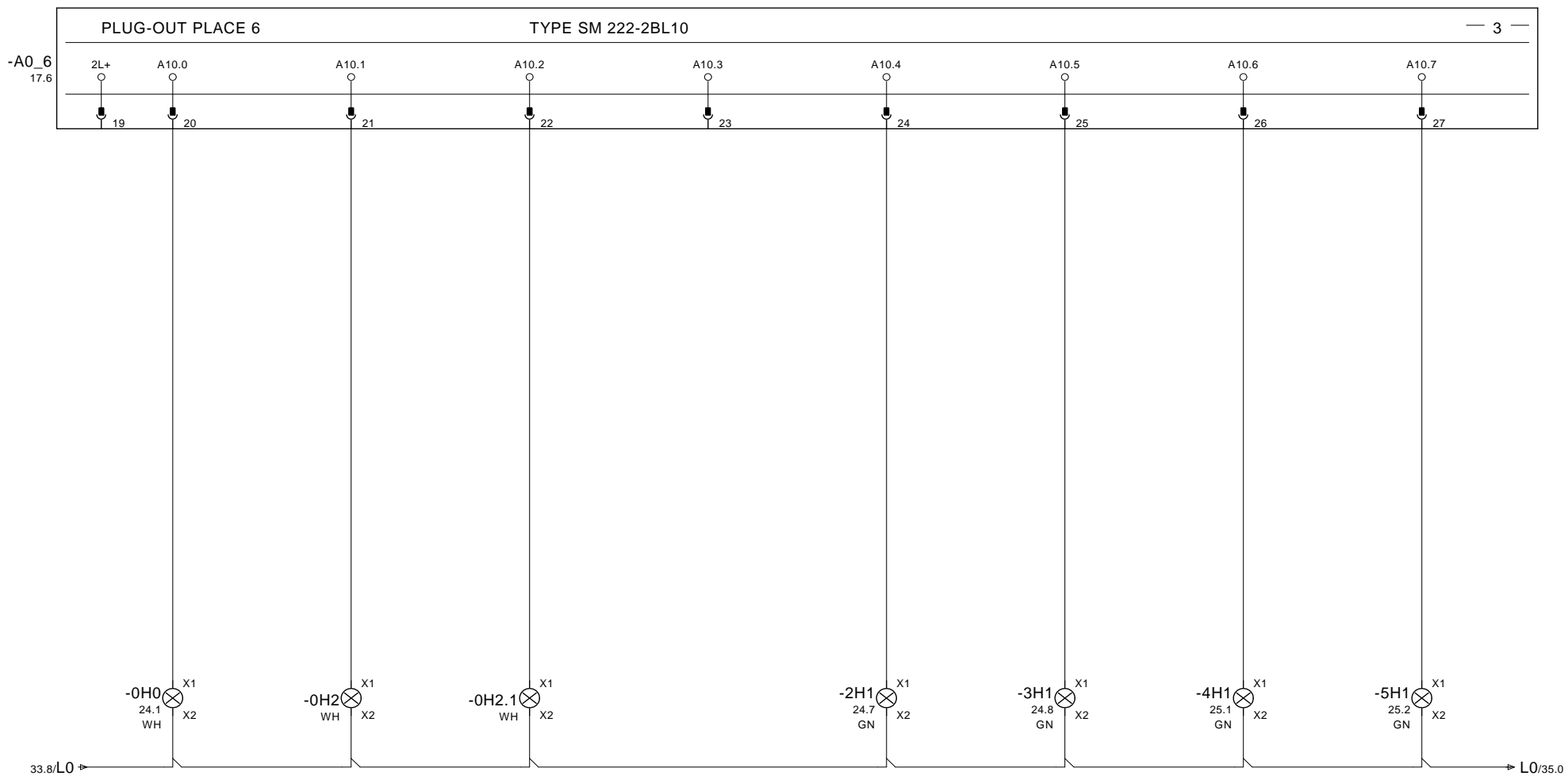

INSTALLATION ON	AUTOMATIC OPERATION	MANUAL OPERATION	SPARE	CONVEYOR BELT 2 ON/OFF	MAGNETIC BELT 3 ON/OFF	CONVEYOR BELT 4 ON/OFF	VIBRATING CHUTE/ CRUSHER 5 ON/OFF
ANLAGE EIN	AUTOMATIKBETRIEB	HANDBETRIEB	RESERVE	FOERDERBAND 2 EIN/AUS	MAGNETBAND 3 EIN/AUS	FOERDERBAND 4 EIN/AUS	FOERDERRINNE 5 EIN/AUS

DATE		04.Dez.2015		KLEEMANN GMBH		 	DIGITALE AUSGAENGE		KLEEMANN SERIES		K007		= 100		+	
EDITED		JBR		MOBICAT MC 120 Z EU			A 10.0 - A 10.7/ DIGITAL OUTPUTS A 10.0 - A 10.7		KLEEMANN MATERIAL NO		2315434		CAE-SYSTEM: EPLAN 5.70		PG. 34	
MODIFICAT.	DATE	NAME	NORM	DIN	ORIGIN	REP.F.	REP.T.							PG. 41		

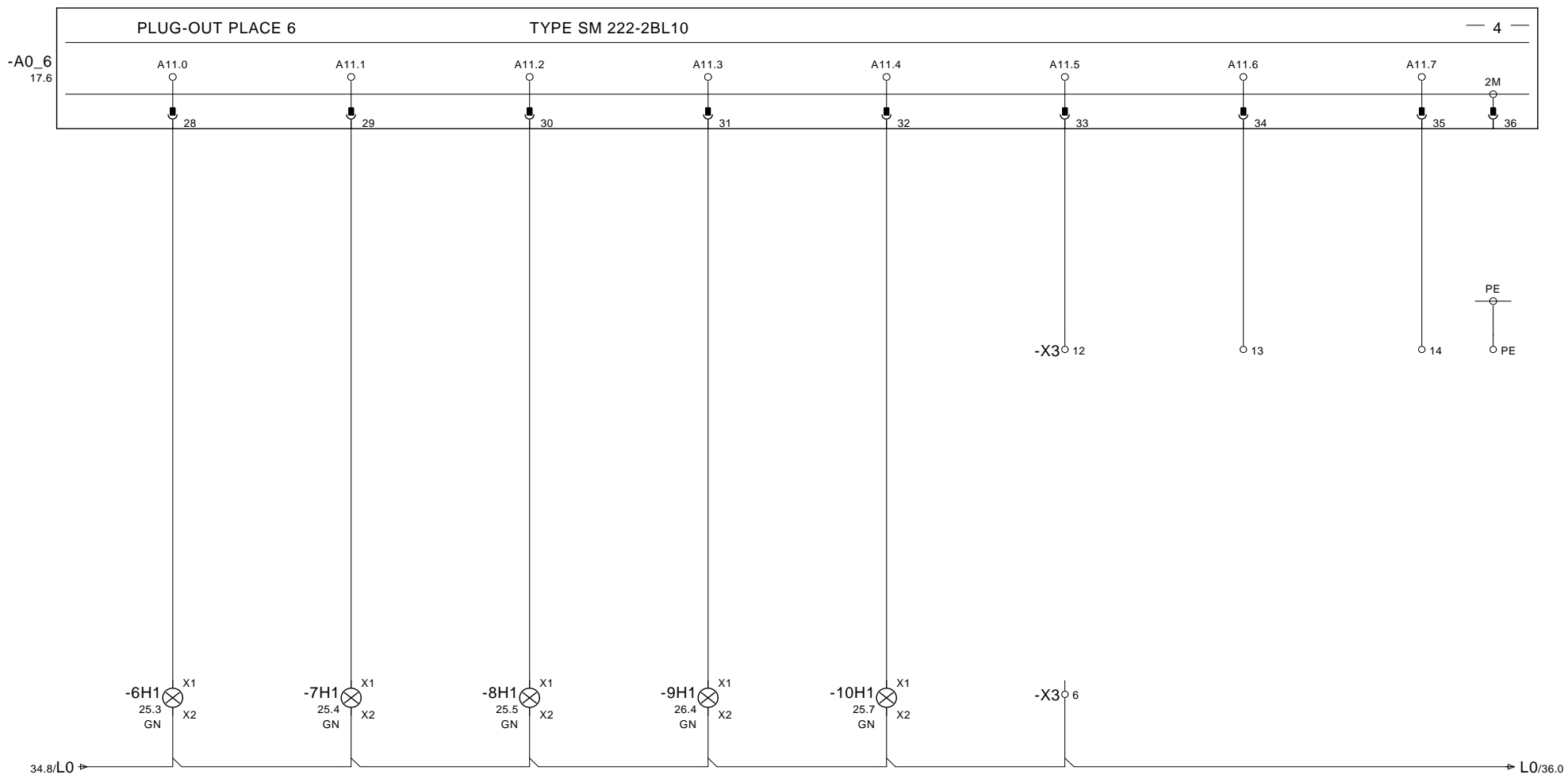

MAGNETIC BELT 6 ON/OFF	CONVEYOR BELT 7 ON/OFF	VIBRATING FEEDER 8 ON/OFF	CONVEYOR BELT 9 ON/OFF	VIBRATING FEEDER 10 ON/OFF	SPARE	SPARE	SPARE
MAGNETBAND 6 EIN/AUS	FOERDERBAND 7 EIN/AUS	AUFGABERINNE 8 EIN/AUS	FOERDERBAND 9 EIN/AUS	AUFGABERINNE 10 EIN/AUS	RESERVE	RESERVE	RESERVE

		DATE	04.Dez.2015		KLEEMANN GMBH		 	DIGITALE AUSGAENGE		KLEEMANN SERIES	K007	= 100	+
		EDITED	JBR		MOBICAT MC 120 Z EU			A 11.0 - A 11.7/ DIGITAL OUTPUTS A 11.0 - A 11.7		KLEEMANN MATERIAL NO	2315434	CAE-SYSTEM: EPLAN 5.70	PG.
MODIFICAT.	DATE	NAME	NORM	DIN	ORIGIN	REP.F.	REP.T.					PG.	41

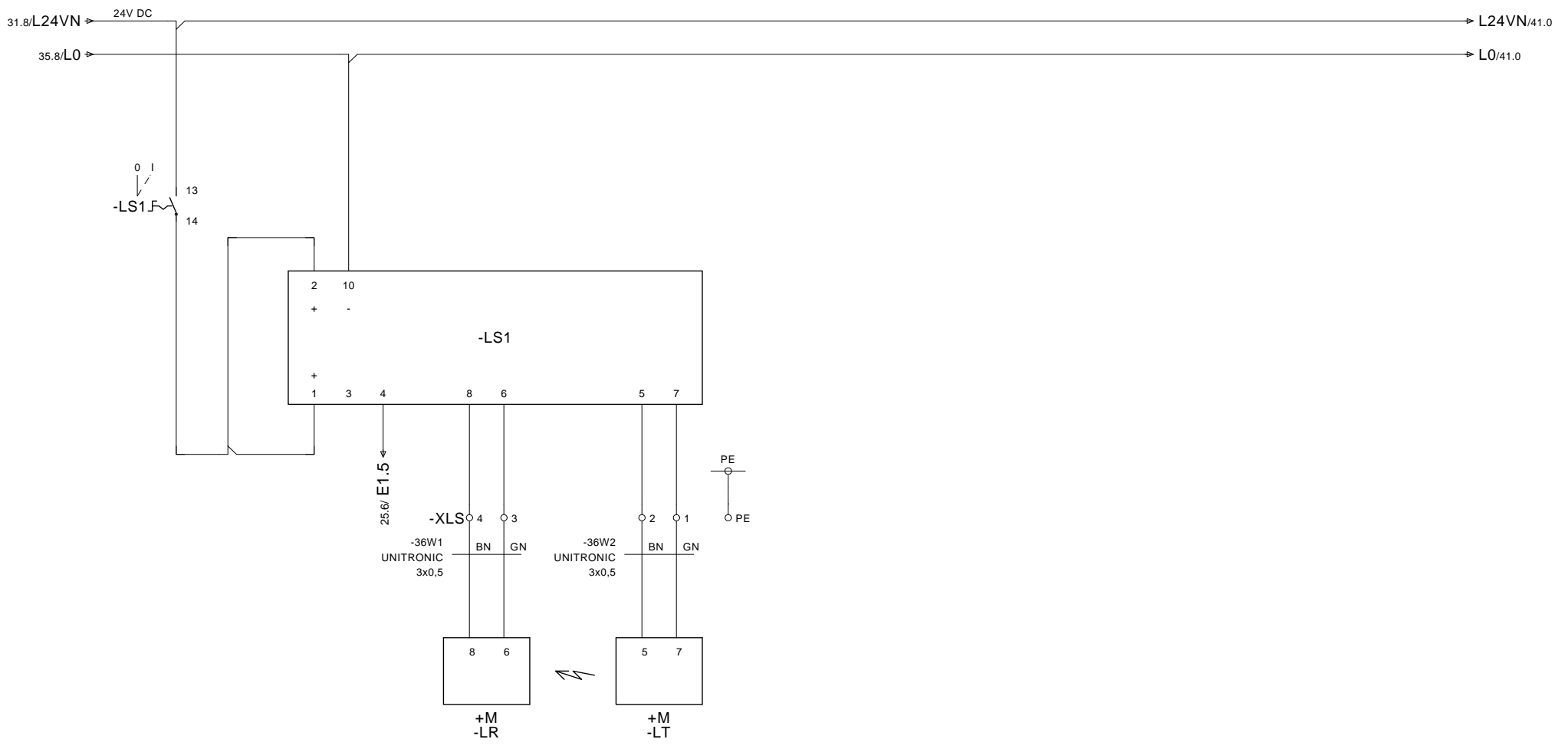

LIGHT BARRIER CRUSHER  
LICHTSCHRANKE BRECHER

		DATE	04.Dez.2015		KLEEMANN GMBH				LICHTSCHRANKE BRECHER/ LIGHT BARRIER CRUSHER	KLEEMANN SERIES	K007	= 100	+		
		EDITED	JBR		MOBICAT MC 120 Z EU					KLEEMANN MATERIAL NO	2315434	CAE-SYSTEM:	EPLAN 5.70	PG.	36
		CONTR.	D. MALLKOWSKY		ORIGIN	REP.F.	REP.T.							PG.	41

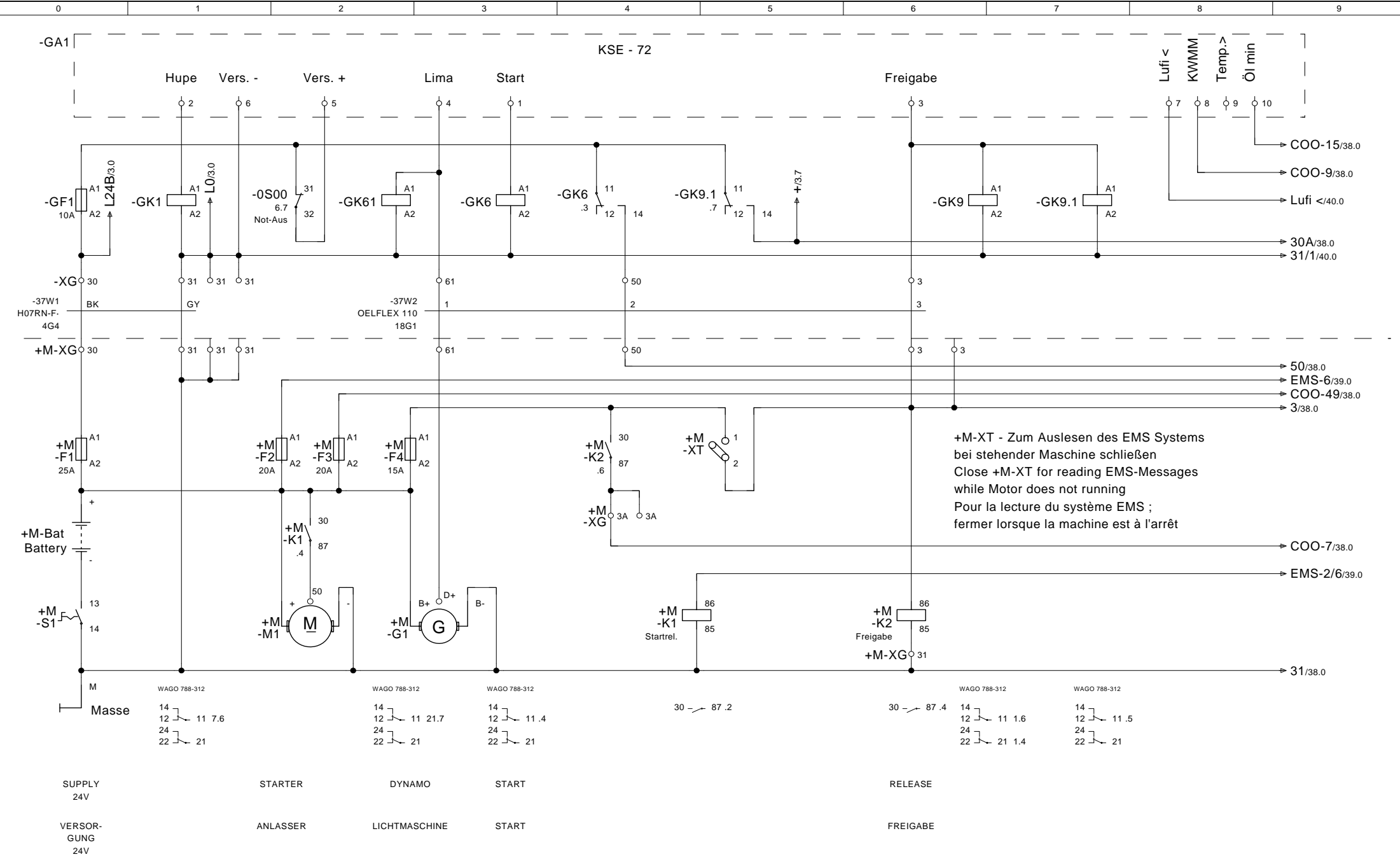

DATE 04.Dez.2015		KLEEMANN GMBH		MOTORUEBERWACHUNG/ MOTOR CONTROLLING		KLEEMANN SERIES K007		= 100		+	
EDITED JBR		MOBICAT MC 120 Z EU		WIRTTGEN GROUP		KLEEMANN MATERIAL NO 2315434		CAE-SYSTEM: EPLAN 5.70		PG. 37	
CONTR. D. MALLKOWSKY		ORIGIN		REP.F.		REP.T.		PG. 41			

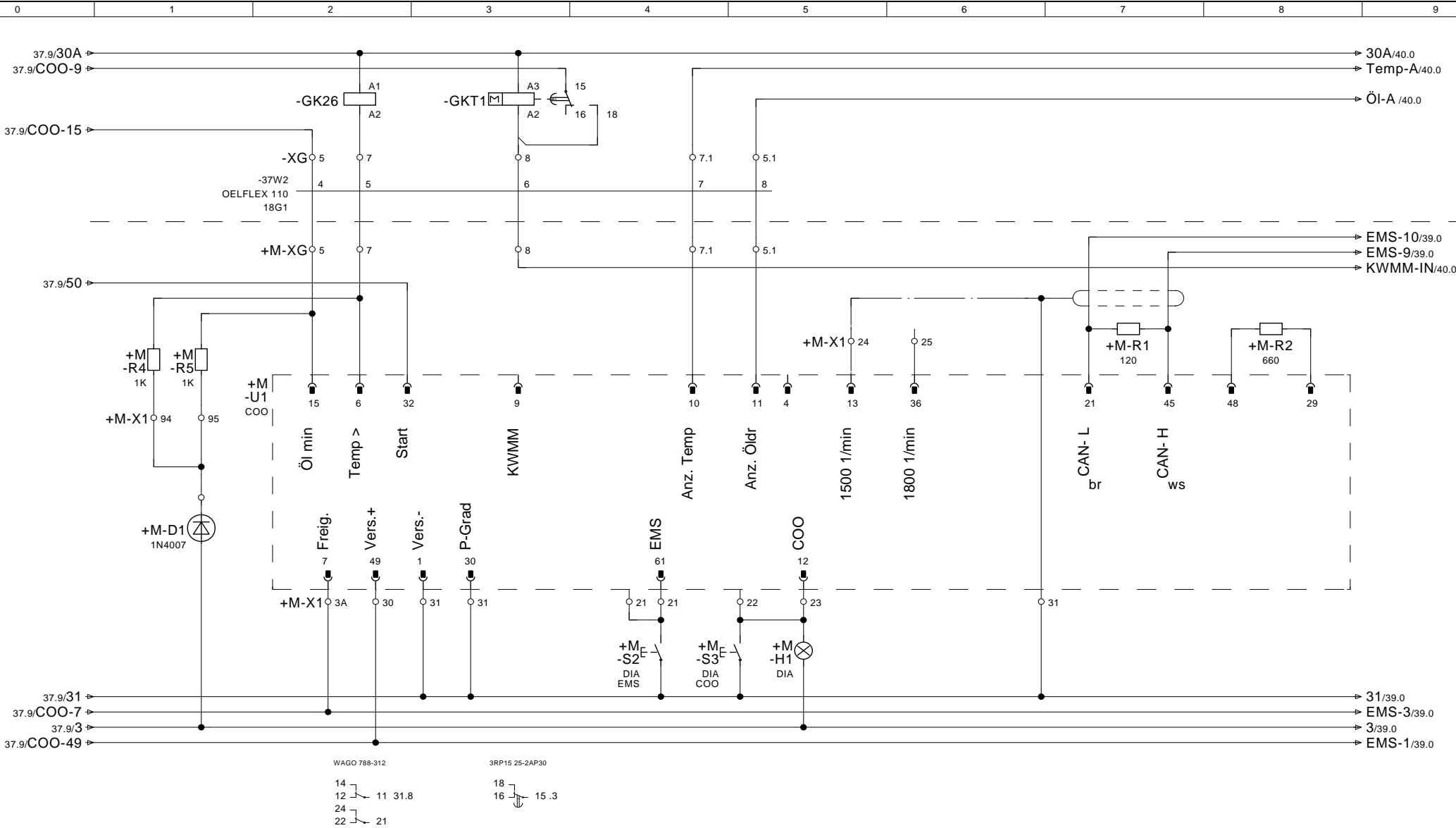

PREWARNING  
OVERTEMPERATURE

COOLING WATER  
LOW LEVEL

VORWARNUNG  
UEBERTEMPERATUR

KUEHLWASSER-  
MANGEL

			DATE	04.Dez.2015	KLEEMANN GMBH			 	COORDINATOR/ COORDINATOR	KLEEMANN SERIES	K007	= 100	+
			EDITED	JBR	MOBICAT MC 120 Z EU					KLEEMANN MATERIAL NO	2315434	CAE-SYSTEM: EPLAN 5.70	PG. 41
MODIFICAT.	DATE	NAME	NORM	DIN	ORIGIN	REP.F.	REP.T.					PG. 38	

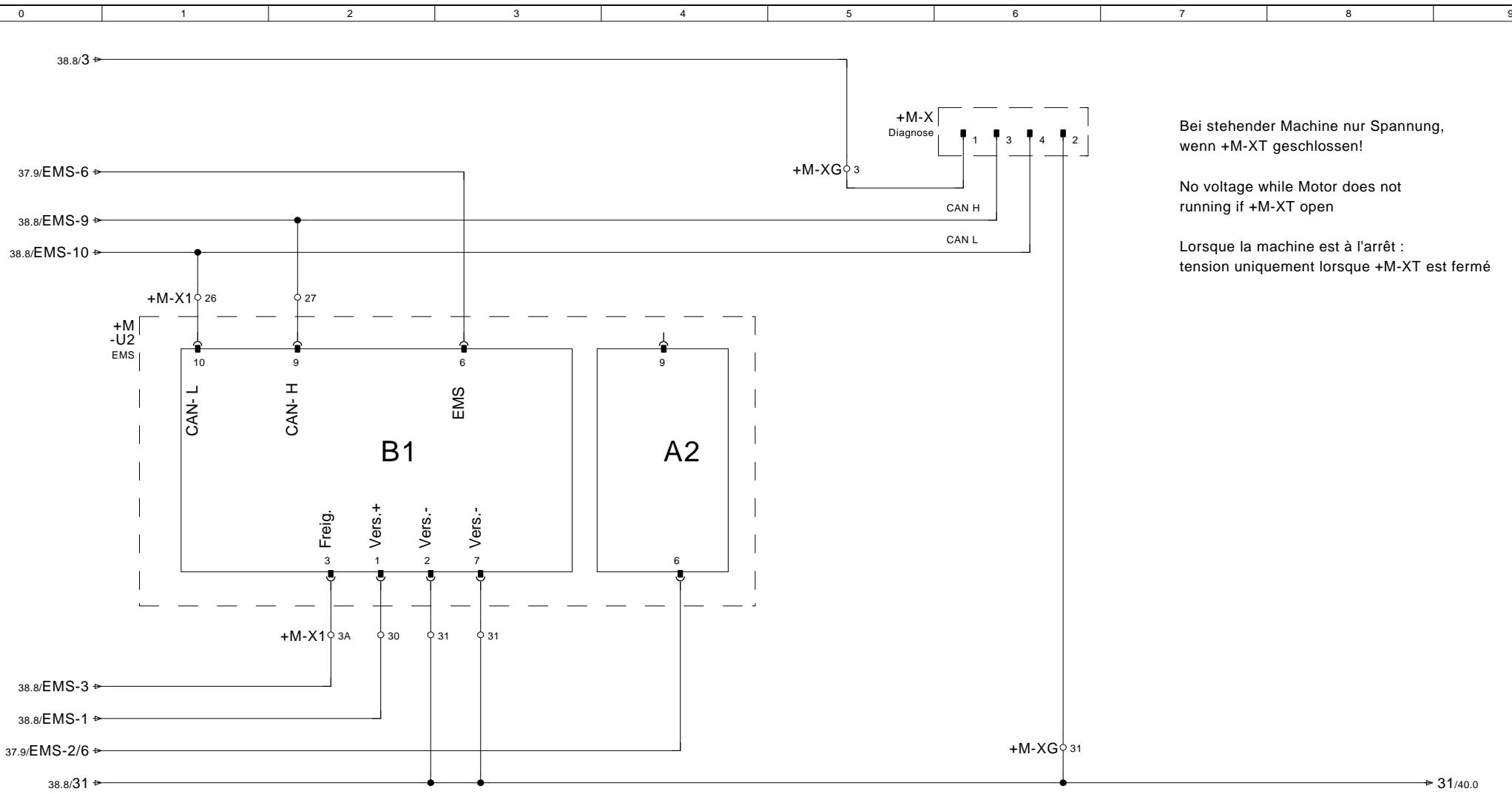

Bei stehender Maschine nur Spannung, wenn +M-XT geschlossen!

No voltage while Motor does not running if +M-XT open

Lorsque la machine est à l'arrêt : tension uniquement lorsque +M-XT est fermé

DIAGNOSTIC

DIAGNOSESTECKER

		DATE	04.Dez.2015		KLEEMANN GMBH			 	EMS	KLEEMANN SERIES	K007	= 100	+
		EDITED	JBR		MOBICAT MC 120 Z EU					KLEEMANN MATERIAL NO	2315434	CAE-SYSTEM: EPLAN 5.70	PG.
MODIFICAT.	DATE	NAME	NORM	DIN	ORIGIN	REP.F.	REP.T.					PG.	41

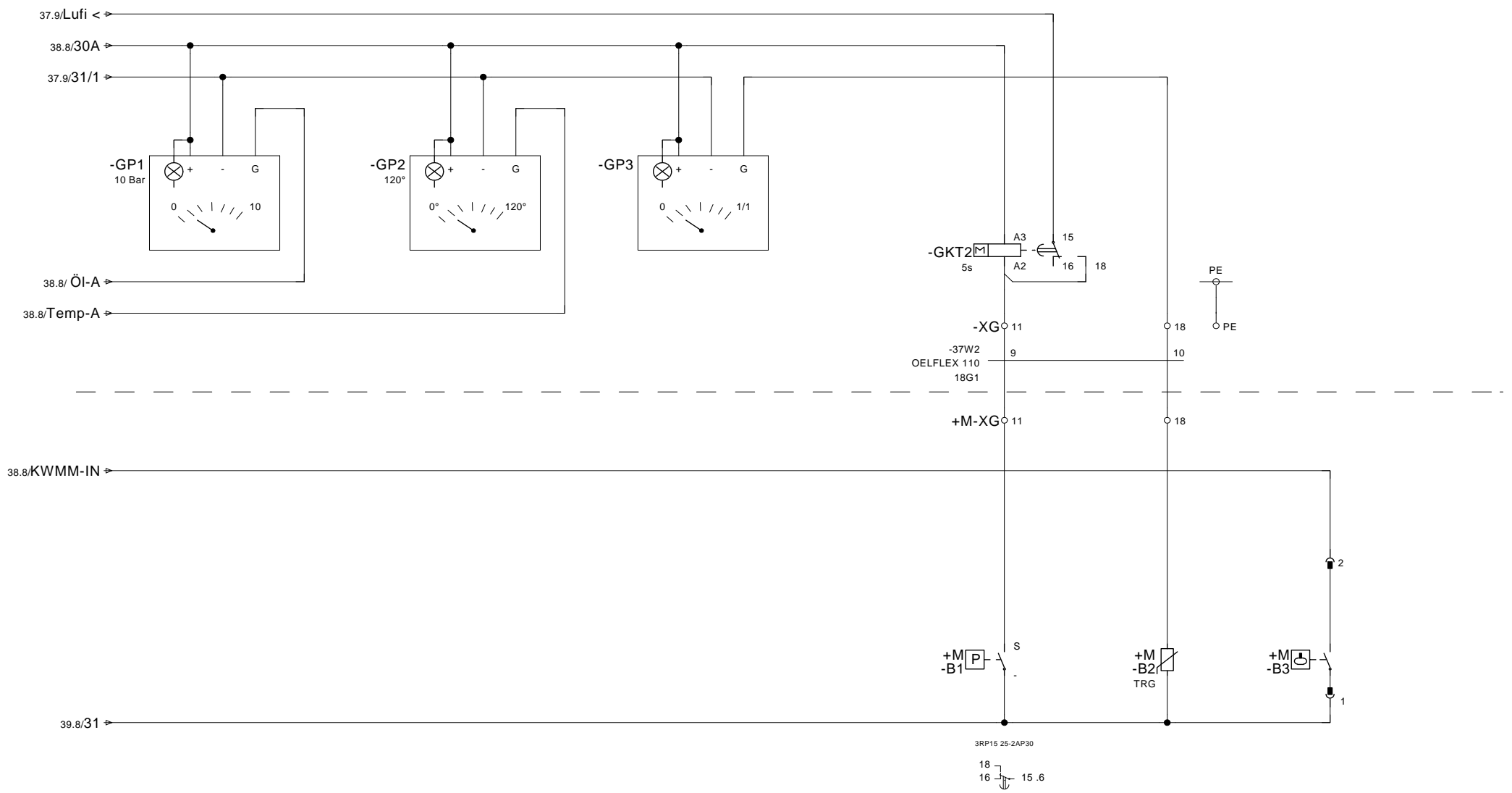

OIL PRESSURE  
OELDRUCK

TEMPERATURE  
TEMPERATUR

FUEL LEVEL  
TANKINHALT

AIR FILTER  
PLUGGES  
LUFTFILTER  
VERSCHMUTZT

FUEL  
LEVEL  
TANKINHALT

COOLING WATER  
LOW LEVEL  
KUEHLWASSER-  
MANGEL

					DATE 04.Dez.2015		KLEEMANN GMBH		  BETRIEBSINSTRUMENTE/ OPERATIONAL INSTRUMENTS		KLEEMANN SERIES K007		= 100		+		
					EDITED JBR		MOBICAT MC 120 Z EU				KLEEMANN MATERIAL NO 2315434		CAE-SYSTEM: EPLAN 5.70		PG. 40		
					CONTR. D. MALLKOWSKY								PG. 41				
MODIFICAT.	DATE	NAME	NORM	DIN	ORIGIN	REP.F.	REP.T.										



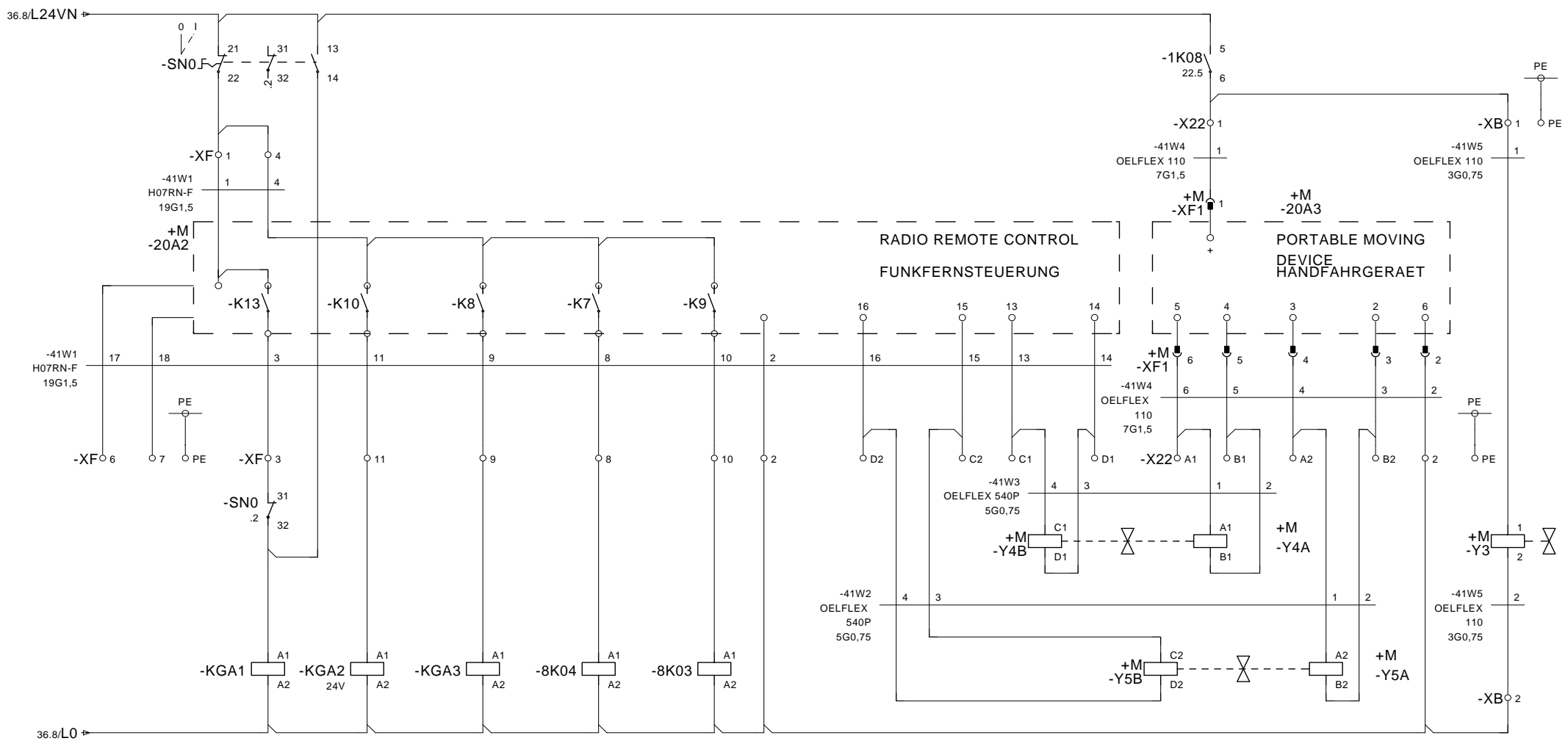

SIE 3RH2122-2BB40	WAGO 788-312	WAGO 788-312	WAGO 788-312	WAGO 788-312
13 → 14 6.5 21 → 22 31 → 32 43 → 44 6.6	14 → 11 26.5 22 → 21	14 → 11 26.6 22 → 21	14 → 11 26.8 24 → 21	14 → 11 26.7 24 → 21

INSTALLATION OFF (RADIO) ANLAGE AUS (FUNK)	VIBRATING CHUTE + SCREEN ON(REMOTE) RINNE + SIEB EIN (FUNK)	VIBRATING CHUTE + SCREEN OFF(REMOTE) RINNE + SIEB AUS (FUNK)	VIBRATING CHUTE FASTER (RADIO) RINNE SCHNELLER (FUNK)	VIBRATING CHUTE SLOWER (RADIO) RINNE LANGSAMER (FUNK)	RUN CHAIN LEFT (REMOTE) FAHREN KETTE LINKS (FUNK)	RUN CHAIN RIGHT (REMOTE) FAHREN KETTE RECHTS (FUNK)	RUN CHAIN RIGHT (MANUAL) FAHREN KETTE RECHTS (HAND)	RUN CHAIN LEFT (MANUAL) FAHREN KETTE LINKS (HAND)	BRACKE VALVE BREMSVENTIL
---	--	---	--	--	--	--	--	--	-----------------------------

DATE 04.Dez.2015		KLEEMANN GMBH			FUNKFERNSTEUERUNG/ RADIO REMOTE CONTROL		KLEEMANN SERIES K007		= 100		+		
EDITED JBR		MOBICAT MC 120 Z EU			KLEEMANN MATERIAL NO 2315434		CAE-SYSTEM: EPLAN 5.70		PG. 41		PG. 41		
CONTR. D. MALLKOWSKY	ORIGIN	REP.F.	REP.T.										

# TERMINAL- /PLUG STRIP OVERVIEW

TPSPST2 31.03.2003

Terminal strip and connector design	Text in terminal and connector strip definition	Terminals / plugs					Graphics page of the terminal strip
		first	Last	Total PE	Total N	Total number	
-X0	KLEMMENLEISTE -X0/TERMINAL STRIP -X0	1	20	0	0	20	=KLE/10
-X1	KLEMMLEISTE -X1/ TERMINAL STRIP -X1	1	PE	10	2	37	=KLE/11
-X3	KLEMMENLEISTE -X3/TERMINAL STRIP -X3	PE	14	1	0	15	=KLE/13
-X6	KLEMMLEISTE -X6/ TERMINAL STRIP -X6	PE	4	1	0	5	=KLE/14
-X8	KLEMMENLEISTE -X8/ TERMINAL STRIP -X8	PE	6	2	0	8	=KLE/15
-X00	KLEMMENLEISTE -X00/TERMINAL STRIP -X00	PE	N-FI	1	5	38	=KLE/16
-X22	KLEMMLEISTE -X22/ TERMINAL STRIP -X22	PE	B2	1	0	7	=KLE/18
-X230	KLEMMENLEISTE -X230/ TERMINAL STRIP -X230	PE	N230	1	0	5	=KLE/19
-XB	KLEMMENLEISTE -XB/ TERMINAL STRIP -XB	PE	2	1	0	3	=KLE/20
-XF	KLEMMLEISTE -XF/ TERMINAL STRIP -XF	PE	D2	1	0	15	=KLE/21
-XG	KLEMMENLEISTE -XG/ TERMINAL STRIP -XG	PE	61	1	0	15	=KLE/22
-XK	KLEMMENLEISTE -XK/ TERMINAL STRIP -XK	PE	2	1	0	3	=KLE/23
-XLS	KLEMMLEISTE -XLS TERMINAL STRIP -XLS	PE	4	1	0	5	=KLE/24
-OX0	KLEMMLEISTE -OX0/ TERMINAL STRIP -OX0	PE	2	1	0	3	=KLE/25
-OX06	KLEMMLEISTE -OX06/TERMINAL STRIP -OX06	PE	2	1	0	3	=KLE/26
-OX07	KLEMMENLEISTE -OX07/ TERMINAL STRIP -OX07	1	2	0	0	2	=KLE/27
+M-XG	KLEMMENLEISTE +M-XG/ TERMINAL STRIP +M-XG	3	61	0	0	20	=KLE/28

TERMINAL- / PLUG STRIP OVERVIEW

TPSPST2 31.03.2003

Terminal strip and connector design	Text in terminal and connector strip definition	Terminals / plugs					Graphics page of the terminal strip
		first	Last	Total PE	Total N	Total number	
-XOUT	STECKER -XOUT/ PLUG -XOUT	1	PE	0	0	18	=KLE/29
-3X2	STECKER -3X2/ PLUG -3X2	1	PE	0	0	5	=KLE/30
-4X1	STECKER -4X1/ PLUG -4X1	1	PE	1	0	8	=KLE/31
-4X2	STECKER -4X2/ PLUG -4X2	1	PE	0	0	5	=KLE/32
+M-XF1	STECKER +M-XF1 PLUG +M-XF1	1	6	0	0	6	=KLE/33
+M-XS2	STECKER +M-XS2/ PLUG +M-XS2	1	4	0	0	4	=KLE/34
+M-XS5	STECKER +M-XS5/ PLUG +M-XS5	1	4	0	0	4	=KLE/35
+M-6X1	STECKER +M-6X1/ PLUG +M-6X1	1	PE	1	0	4	=KLE/36

0		1		2		3		4		5		6		7		8		9	
FUNCTION TEXT		CABLE DESIGNATION/TYP		CABLE DESIGNATION/TYP		CABLE DESIGNATION/TYP		CABLE DESIGNATION/TYP		CABLE DESIGNATION/TYP		CABLE DESIGNATION/TYP		CABLE DESIGNATION/TYP		CABLE DESIGNATION/TYP		PAGE/PATH	
		-06W7 OELFLEX 540P 5G1		-06W7 OELFLEX 540P 5G1		-06W6 OELFLEX 540P 5G1		-06W6 OELFLEX 540P 5G1		-06W5 OELFLEX 540P 5G1		-06W4 OELFLEX 540P 5G1		-06W3 OELFLEX 540P 5G1		-06W2 OELFLEX 540P 5G1		-06W1 OELFLEX 540P 5G1	
		DESIGNATION OF EXTERNAL DESTINATION		CONNECTION		NO.		BRIDGE		DESIGNATION OF INTERNAL DESTINATION		CONNECTION							
		INTERNAL WIRING		PLC DESIGNATION		DESIGNATION OF INTERNAL DESTINATION		CONNECTION											
E-STOP PUSH-BUTTON							1	=100+M-0S01	21	1			=100-0S00	21					=100/6.0
=							3	=100+M-0S01	11	2			=100-0S00	11					=100/6.1
=							2	=100+M-0S01	22	3									=100/6.0
=							1	+M-XS2	1	4									=100/6.1
=							4	=100+M-0S01	12	5									=100/6.0
=							3	+M-XS2	3	6									=100/6.1
=							1	=100+M-0S03	21	7									=100/6.0
=							2	+M-XS2	2	8									=100/6.1
=							3	=100+M-0S03	11	9									=100/6.2
=							4	+M-XS2	4	10									=100/6.2
=							2	=100+M-0S03	22	11									=100/6.2
=							1	=100+M-0S04	21	12									=100/6.2
=							4	=100+M-0S03	12	13									=100/6.3
=							3	=100+M-0S04	11	14									=100/6.4
=							1	+M-XS5	2	15									=100/6.4
=							2	=100+M-0S04	22	16									=100/6.4
=							3	+M-XS5	4	17									=100/6.4
=							4	=100+M-0S04	12	18									=100/6.4
=							2	+M-XS5	1	19									=100/6.4
=							1	=100+M-0S06	21	20									=100/6.4
=							4	+M-XS5	3										=100/6.4
=							3	=100+M-0S06	11										=100/6.4
=							2	=100+M-0S06	22										=100/6.4
=							1	=100+M-0S07	21										=100/6.4
=							4	=100+M-0S06	12										=100/6.4
=							2	=100+M-0S07	11										=100/6.4
=							2	=100+M-0S07	22										=100/6.4
=							4	=100+M-0S07	12										=100/6.4
=								-3X2	1										=100/6.4
=								-3X2	3										=100/6.4

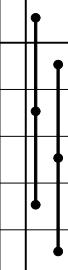

0	1	2	3	4	5	6	7	8	9																								
FUNCTION TEXT	CABLE DESIGNATION/TYP	-12W1 H07RN-F	4G1.5	-11W3 H07RN-F	4G1.5	-11W2 H07RN-F	4G1	-10W2 H07RN-F	5G4	-12W3 H07RN-F	4G1.5	-10W1 H07RN-F	4G1.5	TERMINAL STRIP/PLUG																			
														-X1										DESIGNATION OF EXTERNAL DESTINATION	CONNECTION	NO.	BRIDGE		PLC DESIGNATION	DESIGNATION OF INTERNAL DESTINATION	CONNECTION	CABLE DESIGNATION/TYP	PAGE/PATH
														FIXED	INTERNAL WIRING																		
MAGNETIC BELT 2												BK	=100+M-2M1	U	1				=100-2KC1	2					=100/10.1								
=												BN	=100+M-2M1	V	2				=100-2KC1	4					=100/10.1								
=												GY	=100+M-2M1	W	3				=100-2KC1	6					=100/10.1								
=												GNYE	=100+M-2M1	PE	PE				=100-PE						=100/10.2								
MAGNET												BK	=100+M-2Y1	L1	4				=100-2KC3	2					=100/10.4								
=												BN	=100+M-2Y1	L2	5				=100-2KC3	4					=100/10.4								
=												GY	=100+M-2Y1	L3	6				=100-2KC3	6					=100/10.4								
=												BU	=100+M-2Y1	N	7				=100-0X1	N					=100/10.4								
=												GNYE	=100+M-2Y1	PE	PE				=100-PE						=100/10.5								
VIBRATING CHUTE/CRUSHER 5												BK	=100+M-5M1	U	8				=100-5F1	2					=100/11.4								
=												BN	=100+M-5M1	V	9				=100-5F1	4					=100/11.4								
=												GY	=100+M-5M1	W	10				=100-5F1	6					=100/11.4								
=												GNYE	=100+M-5M1	PE	PE				=100-PE						=100/11.5								
=												BK	=100+M-5M2	U	11				=100-5F2	2					=100/11.7								
=												BN	=100+M-5M2	V	12				=100-5F2	4					=100/11.7								
=												GY	=100+M-5M2	W	13				=100-5F2	6					=100/11.7								
=												GNYE	=100+M-5M2	PE	PE				=100-PE						=100/11.7								
CONVEYOR BELT 6												BK	+M-6X1		14				=100-6KC1	2					=100/12.1								
=												BN	=100+M-6X2		1				+M-6X1														
=												BN	+M-6X1		2				=100-6KC1	4					=100/12.1								
=												GY	=100+M-6X2		2				+M-6X1														
=												GY	+M-6X1		3				=100-6KC1	6					=100/12.1								
=												GY	=100+M-6X2		3																		

DATE		06.Mai.2013		KLEEMANN GMBH		 		KLEMMLEISTE -X1/ TERMINAL STRIP -X1		KLEEMANN SERIES K007		= KLE		+	
EDITED		PC1		MOBICAT MC 120 Z EU						KLEEMANN MATERIAL NO 2315434		CAE-SYSTEM: EPLAN 5.70		PG. 11	
CONTR.		D. MALLKOWSKY												PG. 36	
MODIFICAT.	DATE	NAME	NORM	DIN	ORIGIN	REP.F.	REP.T.								

FUNCTION TEXT		CABLE DESIGNATION/TYPE	-13W3 H07RN-F	-13W2 H07RN-F	-13W1 H07RN-F	-12W4 H07RN-F	-12W3 H07RN-F	-12W1 H07RN-F	DESIGNATION OF EXTERNAL DESTINATION	CONNECTION	NO.	BRIDGE	INTERNAL WIRING	PLC DESIGNATION	DESIGNATION OF INTERNAL DESTINATION	CONNECTION	CABLE DESIGNATION/TYPE	PAGE/PATH
CONVEYOR BELT 6								GNYE	+M-6X1	PE	PE				=100-PE			=100/12.2
VIBRATING SCREEN 7							BK	GNYE	=100+M-6X2	PE	17				=100-7F2	2		=100/12.4
=							BN		=100+M-7M1	V1	18				=100-7F2	4		=100/12.4
=							GY		=100+M-7M1	W1	19				=100-7F2	6		=100/12.4
=							GNYE		=100+M-7M1	PE	PE				=100-PE			=100/12.4
HYDRAULIC 9						BK			=100+M-9M1	U	20				=100-9KC1	2		=100/13.1
=						BN			=100+M-9M1	V	21				=100-9KC1	4		=100/13.1
=						GY			=100+M-9M1	W	22				=100-9KC1	6		=100/13.1
=						GNYE			=100+M-9M1	PE	PE				=100-PE			=100/13.2
WATERPUMP 10						BN			=100+M-WP	L1	23				=100-10KC1	2		=100/13.4
=						BU			=100+M-WP	N	24							=100/13.5
=						GNYE			=100+M-WP	PE	PE				=100-PE			=100/13.5
OVERPRESSURE FAN						BK			=100+M-13M1	U	25				=100-13Q1	2		=100/13.7
=						BN			=100+M-13M1	V	26				=100-13Q1	4		=100/13.7
=						GY			=100+M-13M1	W	27				=100-13Q1	6		=100/13.7
=						GNYE			=100+M-13M1	PE	PE				=100-PE			=100/13.7
CRUSHER 1									=100+M-1M1	PE	PE				=100-PE			=100/8.7

DATE		06.Mai.2013		KLEEMANN GMBH		 		KLEEMANN SERIES		K007		= KLE		+	
EDITED		PC1		MOBICAT MC 120 Z EU		 		KLEEMANN MATERIAL NO		2315434		CAE-SYSTEM: EPLAN 5.70		PG. 12	
CONTR.		D. MALLKOWSKY		ORIGIN		REP.F.		REP.T.						PG. 36	

FUNCTION TEXT	CABLE DESIGNATION/TYP											TERMINAL STRIP/PLUG						CABLE DESIGNATION/TYP	PAGE/ PATH
												-X3							
												DESIGNATION OF EXTERNAL DESTINATION	CONNECTION	NO.	BRIDGE	PLC DESIG- NATION	DESIGNATION OF INTERNAL DESTINATION		
SPARE											PE				=100-PE		=100/35.8		
E-STOP PUSH-BUTTON						-4X2	2				1	●					=100/6.5		
=						=100-KGA1	13				2	●					=100/6.5		
=						-4X2	4				3	●					=100/6.6		
=						=100-KGA1	43				4	●					=100/6.6		
SPARE											5				=100-S5.2	13	=100/29.4		
=											6				=100-8S	13			
=											6				=100-10H1	X2	=100/35.6		
=											6				=100-LS1	10			
=											7		E5.3	-A0_5	13		=100/29.4		
=											8		E5.4	-A0_5	14		=100/29.5		
=											9		E5.5	-A0_5	15		=100/29.6		
VIBRATING FEEDER 8 +											10		E5.6	-A0_5	16		=100/29.7		
VIBRATING FEEDER 8 -											11		E5.7	=100-8S	14				
											11		E5.7	-A0_5	17		=100/29.8		
SPARE											12		A11.5	=100-8S	24				
=											12		A11.5	-A0_6	33		=100/35.6		
=											13		A11.6	-A0_6	34		=100/35.7		
=											14		A11.7	-A0_6	35		=100/35.8		

FUNCTION TEXT	CABLE DESIGNATION/TYPE								-07W3 OE FLEX 110 3G0.75	-07W2 OE FLEX 110 3G0.75	DESIGNATION OF EXTERNAL DESTINATION	CONNECTION	NO.	BRIDGE		PLC DESIGN-NATION	DESIGNATION OF INTERNAL DESTINATION	CONNECTION				CABLE DESIGNATION/TYPE	PAGE/ PATH
														FIXED	INTERNAL WIRING								
FLASHING LIGHT															PE			=100-PE					=100/7.8
HOOTER										1	=100+M-00H2	1			1			=100-GK1	14				=100/7.6
=										2	=100+M-00H2	2		2	•			-XK	2				=100/7.6
FLASHING LIGHT									1		=100+M-00H3	X1		3	•			=100-00K3	14				=100/7.8
=									2		=100+M-00H3	X2		4	•			=100-1F1	B2				=100/7.8

		DATE	06.Mai.2013		KLEEMANN GMBH						KLEMMLEISTE -X6/				KLEEMANN SERIES		K007		= KLE		+	
		EDITED	PC1		MOBICAT MC 120 Z EU						TERMINAL STRIP -X6				KLEEMANN MATERIAL NO		2315434		CAE-SYSTEM: EPLAN 5.70		PG. 14	
MODIFICAT.	DATE	NAME	NORM	DIN	ORIGIN	REP.F.		REP.T.													PG. 36	



0	1	2	3	4	5	6	7	8	9							
FUNCTION TEXT	CABLE DESIGNATION/TYP					DESIGNATION OF EXTERNAL DESTINATION	CONNECTION	NO.	FIXED	BRIDGE	INTERNAL WIRING	PLC DESIGNATION	DESIGNATION OF INTERNAL DESTINATION	CONNECTION	CABLE DESIGNATION/TYP	PAGE/PATH
VIBRATING FEEDER 8 DRIVE LEFT						PE =100+M-8M1	PE		PE				=100-8A1	PE		=100/14.3
=						1 =100+M-8M1	U1	1					=100-8F2	2		=100/14.2
=						2 =100+M-8M1	V1	2					=100-8F2	4		=100/14.2
=						3 =100+M-8M1	W1	3					=100-8F2	6		=100/14.3
VIBRATING FEEDER 8 DRIVE RIGHT						PE =100+M-8M2	PE		PE				=100-8A1	PE		=100/14.5
=						1 =100+M-8M2	U1	4					=100-8F3	2		=100/14.4
=						2 =100+M-8M2	V1	5					=100-8F3	4		=100/14.4
=						3 =100+M-8M2	W1	6					=100-8F3	6		=100/14.4

FUNCTION TEXT	CABLE DESIGNATION/TYP	TERMINAL STRIP/PLUG												CABLE DESIGNATION/TYP	PAGE/PATH	
		-X00														
		DESIGNATION OF EXTERNAL DESTINATION	CONNECTION	NO.	BRIDGE		PLC DESIGNATION	DESIGNATION OF INTERNAL DESTINATION	CONNECTION							
FIXED	INTERNAL WIRING															
SOCKET 16A/230V														=100-PE		=100/4.4
CONTROL VOLTAGE ON		=100+S-XSBT1	7	1	●		=100-0K1	4							=100/7.4	
		=100-SC	13	1	●		=100-8A1	T6							=100/17.1	
		=100-A0_OP-X1	L+	1	●										=100/17.2	
		=100-A0_CPU	1	1	●										=100/17.3	
		-A0_2	1	1	●										=100/17.3	
		-A0_2	1	1	●										=100/17.4	
		-A0_3	1	1	●		-A0_2	2							=100/17.4	
INSTALLATION ON		=100-S0.0	13	1	●		=100-GK61	11							=100/24.1	
CONVEYOR BELT 4 ON/OFF		=100-4S1	13	1	●		=100-7F2	31							=100/25.1	
SPARE		-A0_5	11	1	●	E5.1	=100-8Q1	13							=100/29.2	
							=100-S5.2	13								
SUPPLY 24V AFTER EMERGENCY STOP		=100-KN1	A2	2	●		=100-D1	A2							=100/7.1	
=		=100-KN2	A2	2	●										=100/7.2	
=		=100-TK1		2	●										=100/7.2	
CONTROL VOLTAGE ON		=100-0K1	A2	2	●		-XK	2							=100/7.3	
ILLUMINATION 1		-0X06	2	2	●		-XG	31							=100/3.1	
ILLUMINATION 2		-0X07	2	2	●										=100/3.3	
BELT WEIGHER		-0X0	2	2	●		=100-KX	A2							=100/3.5	
		=100-A_FW-X1	0V	2	●		=100-7F2	B2							=100/17.1	
		=100-A0_OP-X1	M	2	●										=100/17.2	
		=100-A0_CPU	2	2	●										=100/17.2	
		-A0_2	18	2	●										=100/17.3	

# TERMINAL STRIP/PLUG

## -X00

FUNCTION TEXT	CABLE DESIGNATION/TYPE	DESIGNATION OF EXTERNAL DESTINATION	CONNECTION	NO.	BRIDGE	INTERNAL WIRING	PLC DESIGNATION	DESIGNATION OF INTERNAL DESTINATION	CONNECTION	CABLE DESIGNATION/TYPE	PAGE/PATH
		-A0_2	18	2	●						=100/17.3
		-A0_3	18	2	●						=100/17.4
		-A0_4	18	2	●						=100/17.5
		-A0_4	36	2	●						=100/17.5
		-A0_5	18	2	●						=100/17.6
		-A0_5	36	2	●						=100/17.6
		-A0_6	18	2	●						=100/17.7
		-A0_6	36	2	●						=100/17.7
SET VALUE FREQUENCY CONVERTER VIBRATING FEEDER 8		-A0_2	14	2	●			=100-1K1	A2		=100/19.3
SUPPLY 24V AFTER EMERGENCY STOP		=100-KN2	14	3	●						=100/7.2
=				3	●						=100/7.2
		-A0_6	1	3	●						=100/17.6
		-A0_6	19	3	●						=100/17.6
TOTAL FAULT CURRENT PROTECTION		=100-P5		N	●			=100-0F01	8		=100/1.7
=				N	●						=100/1.7
=				N	●			=100-0F04	N		=100/1.7
SOCKET 32A		=100-0X4	N	N-FI	●			=100-0F04	NFI		=100/4.2
SOCKET 16A/230V		=100-0X5	N	N-FI	●						=100/4.3

	DATE	06.Mai.2013		KLEEMANN GMBH			KLEEMANN SERIES	K007		= KLE	+
	EDITED	PC1		MOBICAT MC 120 Z EU			KLEEMANN MATERIAL NO	2315434		CAE-SYSTEM: EPLAN 5.70	PG. 17
MODIFICAT.	DATE	NAME	NORM	DIN	ORIGIN	REP.F.	REP.T.			PG.	36

FUNCTION TEXT		CABLE DESIGNATION/TYP				TERMINAL STRIP/PLUG -X22								CABLE DESIGNATION/TYP		PAGE/ PATH	
						DESIGNATION OF EXTERNAL DESTINATION	CONNECTION	NO.	BRIDGE		PLC DESIG- NATION	DESIGNATION OF INTERNAL DESTINATION	CONNECTION				
									-41W2 OEFLEX 540P 5G0.75	-41W3 OEFLEX 540P 5G0.75				-41W4 OEFLEX 110 7G1.5	FIXED	INTERNAL WIRING	
RUN CHAIN LEFT (MANUAL)						=100-PE											
EINSPEISUNG 24V DC						1 +M-XF1	1	1				=100-1K08	6				=100/41.7
EINSPEISUNG 0V DC						2 +M-XF1	2	2				-XB	1				
RUN CHAIN RIGHT (MANUAL)						6 +M-XF1	6					-XF	2				=100/41.9
RUN CHAIN LEFT (MANUAL)						4 +M-XF1	4	A1				-XB	2				=100/41.7
RUN CHAIN RIGHT (MANUAL)						5 +M-XF1	5	B1									=100/41.7
RUN CHAIN LEFT (MANUAL)						4 +M-XF1	4	A2									=100/41.8
RUN CHAIN RIGHT (MANUAL)						5 +M-XF1	5	B1									=100/41.7
RUN CHAIN LEFT (MANUAL)						3 +M-XF1	3	B2									=100/41.8
						=100+M-Y4B	A1										
						=100+M-Y5B	A2										
						=100+M-Y4B	B1										
						=100+M-Y5B	B2										

17

19



FUNCTION TEXT	CABLE DESIGNATION/TYPE	3G0.75	TERMINAL STRIP/PLUG -XB							CABLE DESIGNATION/TYPE	PAGE/ PATH
			DESIGNATION OF EXTERNAL DESTINATION	CONNECTION	NO.	BRIDGE		DESIGNATION OF INTERNAL DESTINATION	CONNECTION		
						FIXED	INTERNAL WIRING				
BRACKE VALVE						PE			=100-PE		=100/41.9
=			1 =100+M-Y3	1	1				-X22	1	=100/41.9
=			2 =100+M-Y3	2	2				-X22	2	=100/41.9

0	1	2	3	4	5	6	7	8	9								
FUNCTION TEXT	CABLE DESIGNATION/TYPE					DESIGNATION OF EXTERNAL DESTINATION	CONNECTION	NO.	FIXED	BRIDGE	INTERNAL WIRING	PLC DESIGNATION	DESIGNATION OF INTERNAL DESTINATION	CONNECTION	CABLE DESIGNATION/TYPE	PAGE/PATH	
						=100-PE			PE							=100/41.1	
						1 =100+M-20A2		1					=100-SN0	22		=100/41.1	
VIBRATING CHUTE SLOWER (RADIO)					2 =100+M-20A2		2						=100-8K03	A2			=100/41.5
INSTALLATION OFF (RADIO)					3 =100+M-20A2		3						-X22	2			=100/41.2
=					4 =100+M-20A2		4						=100-SN0	31			=100/41.2
						17 =100+M-20A2		6								=100/41.1	
						18 =100+M-20A2		7								=100/41.1	
VIBRATING CHUTE FASTER (RADIO)						8 =100+M-20A2		8					=100-8K04	A1		=100/41.4	
VIBRATING CHUTE + SCREEN OFF(REMOTE)						9 =100+M-20A2		9					=100-KGA3	A1		=100/41.3	
VIBRATING CHUTE SLOWER (RADIO)						10 =100+M-20A2		10					=100-8K03	A1		=100/41.4	
VIBRATING CHUTE + SCREEN ON(REMOTE)						11 =100+M-20A2		11					=100-KGA2	A1		=100/41.2	
RUN CHAIN RIGHT (REMOTE)						13 =100+M-20A2	13		C1							=100/41.6	
RUN CHAIN LEFT (REMOTE)						15 =100+M-20A2			C2							=100/41.6	
RUN CHAIN RIGHT (REMOTE)					3	14 =100+M-20A2			D1							=100/41.7	
RUN CHAIN LEFT (REMOTE)						16 =100+M-20A2			D2							=100/41.5	
					4	=100+M-Y5B			D2								

DATE		06.Mai.2013		KLEEMANN GMBH		 		KLEEMANN SERIES		K007		= KLE		+	
EDITED		PC1		MOBICAT MC 120 Z EU		KLEMMLEISTE -XF/ TERMINAL STRIP -XF		KLEEMANN MATERIAL NO		2315434		CAE-SYSTEM: EPLAN 5.70		PG. 21	
CONTR.		D. MALLKOWSKY		ORIGIN		REP.F.		REP.T.						PG. 36	

FUNCTION TEXT		CABLE DESIGNATION/TYPE		DESIGNATION OF EXTERNAL DESTINATION		CONNECTION	NO.	FIXED	BRIDGE	INTERNAL WIRING	PLC DESIGNATION	DESIGNATION OF INTERNAL DESTINATION	CONNECTION	CABLE DESIGNATION/TYPE	PAGE/PATH
FUEL LEVEL							PE					=100-PE			=100/40.7
RELEASE				3 +M-XG		3	3					=100-GA1	3		=100/37.6
				4 +M-XG		5	5					=100-GK9	A1		
												=100-GA1	10_2		=100/38.2
COOLING WATER LOW LEVEL				8 +M-XG		5.1	5.1					=100-GP1	G		=100/38.5
PREWARNING OVERTEMPERATURE				5 +M-XG		7	7					=100-GK26	A2		=100/38.2
COOLING WATER LOW LEVEL				7 +M-XG		7.1	7.1					=100-GP2	G		=100/38.4
=				6 +M-XG		8	8					=100-GKT1	A2		=100/38.3
AIR FILTER PLUGGES				9 +M-XG		11	11					=100-GKT2	A2		=100/40.6
FUEL LEVEL				10 +M-XG		18	18					=100-GP3	G		=100/40.7
SUPPLY 24V				+M-XG		30	30					=100-GF1	A2		=100/37.0
SUPPLY 0V				+M-XG		31	31					=100-0F06	1		
=												=100-GK1	A2		=100/37.1
=												-X00	2		=100/37.1
=												=100-GA1	6		=100/37.1
START				2 +M-XG		50	50					=100-GK61	A2		
												=100-GK6	14		=100/37.4
DYNAMO				1 +M-XG		61	61					=100-GA1	4		=100/37.3



0	1	2	3	4	5	6	7	8	9					
FUNCTION TEXT				CABLE DESIGNATION/TYP	3G1.5	TERMINAL STRIP/PLUG -XK					CABLE DESIGNATION/TYP	PAGE/ PATH		
				-07W1 DELFLEX 110	DESIGNATION OF EXTERNAL DESTINATION	CONNECTION	NO.	BRIDGE	INTERNAL WIRING	PLC DESIG- NATION	DESIGNATION OF INTERNAL DESTINATION	CONNECTION		
COUPLING											=100-PE			=100/7.5
=					=100+M-Y10		1				=100-1K08	2		=100/7.5
=					=100+M-Y10		2				-X00	2		=100/7.5
											-X6	2		

DATE	06.Mai.2013	KLEEMANN GMBH		 	KLEEMANN SERIES	K007	= KLE	+
EDITED	PC1	MOBICAT MC 120 Z EU			KLEMMENLEISTE -XK/ TERMINAL STRIP -XK	KLEEMANN MATERIAL NO	2315434	CAE-SYSTEM: EPLAN 5.70
CONTR.	D. MALLKOWSKY	ORIGIN	REP.F.	REP.T.				
MODIFICAT.	DATE	NAME	NORM	DIN				

FUNCTION TEXT	CABLE DESIGNATION/TYP						-36W1 UNITRONIC 3x0.5mm <sup>2</sup>	-36W2 UNITRONIC 3x0.5mm <sup>2</sup>	DESIGNATION OF EXTERNAL DESTINATION	CONNECTION	NO.	BRIDGE		PLC DESIGNATION	DESIGNATION OF INTERNAL DESTINATION	CONNECTION	CABLE DESIGNATION/TYP	PAGE/PATH
												FIXED	INTERNAL WIRING					
LIGHT BARRIER CRUSHER											PE				=100-PE			=100/36.4
=								GN	=100+M-LT	7	1				=100-LS1	7		=100/36.4
=								BN	=100+M-LT	5	2				=100-LS1	5		=100/36.4
=							GN		=100+M-LR	6	3				=100-LS1	6		=100/36.3
=							BN		=100+M-LR	8	4				=100-LS1	8		=100/36.3

		DATE	06.Mai.2013	KLEEMANN GMBH		KLEEMANN SERIES	K007	= KLE	+
		EDITED	PC1	MOBICAT MC 120 Z EU		KLEEMANN MATERIAL NO	2315434	CAE-SYSTEM:	EPLAN 5.70
MODIFICAT.	DATE	NAME	NORM	DIN	ORIGIN	REP.F.	REP.T.	PG.	24
								PG.	36



KLEMMLEISTE -XLS  
TERMINAL STRIP -XLS

KLEEMANN SERIES  
K007  
KLEEMANN MATERIAL NO  
2315434

= KLE +  
CAE-SYSTEM:  
EPLAN 5.70  
PG. 24  
PG. 36

# TERMINAL STRIP/PLUG -0X0

FUNCTION TEXT	CABLE DESIGNATION/TYP	3G1.5	-03W2 H07RN-F	DESIGNATION OF EXTERNAL DESTINATION	CONNECTION	NO.	FIXED	BRIDGE		PLC DESIGNATION	DESIGNATION OF INTERNAL DESTINATION	CONNECTION	CABLE DESIGNATION/TYP	PAGE/PATH
								INTERNAL WIRING						
BELT WEIGHER				GNYE =100+M-B1	PE	PE					=100-PE			=100/3.5
=				BN =100+M-B1	1	1					=100-0K1	24		=100/3.5
=				BU =100+M-B1	2	2					-X00	2		=100/3.5

DATE	06.Mai.2013	KLEEMANN GMBH		KLEMMLEISTE -0X0/ TERMINAL STRIP -0X0	KLEEMANN SERIES	K007	= KLE	+
EDITED	PC1				KLEEMANN MATERIAL NO	2315434		
CONTR.	D. MALLKOWSKY	MOBICAT MC 120 Z EU		REP.T.				PG. 36
MODIFICAT.	DATE	NAME		NORM	DIN	ORIGIN	REP.F.	

0	1	2	3	4	5	6	7	8	9											
FUNCTION TEXT					5G1.5	<b>TERMINAL STRIP/PLUG</b>  -0X06				CABLE DESIGNATION/TYPE	PAGE/ PATH									
												CABLE DESIGNATION/TYPE	DESIGNATION OF EXTERNAL DESTINATION	CONNECTION	NO.	FIXED	BRIDGE INTERNAL WIRING	PLC DESIGNATION	DESIGNATION OF INTERNAL DESTINATION	CONNECTION
ILLUMINATION 1																				
=					BK	=100+M-E1	X1	1												
=					BN	=100+M-E1	X2	2												

FUNCTION TEXT	CABLE DESIGNATION/TYPE									TERMINAL STRIP/PLUG							CABLE DESIGNATION/TYPE	PAGE/PATH
		-03W1 H07RN-F	5G1.5	DESIGNATION OF EXTERNAL DESTINATION	CONNECTION	NO.	BRIDGE		DESIGNATION OF INTERNAL DESTINATION	CONNECTION								
							FIXED	INTERNAL WIRING							PLC DESIGNATION			
ILLUMINATION 2		GY	=100+M-E2	X1	1					=100-KX	24				=100/3.3			
=		BU	=100+M-E2	X2	2					-X00	2				=100/3.3			

MODIFICAT.	DATE	NAME	NORM	DIN	ORIGIN	REP.F.	REP.T.	  <b>KLEMMENLEISTE -0X07/ TERMINAL STRIP -0X07</b>	KLEEMANN SERIES <b>K007</b>	<b>= KLE</b> +
									KLEEMANN MATERIAL NO <b>2315434</b>	CAE-SYSTEM: EPLAN 5.70

FUNCTION TEXT	CABLE DESIGNATION/TYP												TERMINAL STRIP/PLUG +M-XG				CABLE DESIGNATION/TYP	PAGE/PATH	
		DESIGNATION OF EXTERNAL DESTINATION	CONNECTION	NO.	BRIDGE		PLC DESIGNATION	DESIGNATION OF INTERNAL DESTINATION	CONNECTION										
					INTERNAL WIRING														
RELEASE								3	-XG	3				=100-K2	86				=100/37.6
=										3				=100-D1	-2				=100/37.6
DIAGNOSTIC								1	=100-X	3				=100-D1	-2				=100/39.5
START								3A	-X1	3A				=100-K2	87				=100/37.4
=										3A									=100/37.4
								4	-XG	5				-U1	15				=100/38.2
COOLING WATER LOW LEVEL								8	-XG	5.1				-U1	11				=100/38.5
PREWARNING OVERTEMPERATURE								5	-XG	7				-U1	6				=100/38.2
COOLING WATER LOW LEVEL								7	-XG	7.1				-U1	10				=100/38.4
=								6	-XG	8				2					=100/38.3
AIR FILTER PLUGGES								9	-XG	11				=100-B1	S				=100/40.6
FUEL LEVEL								10	-XG	18				=100-B2					=100/40.7
SUPPLY 24V									-XG	30				=100-F1	A1				=100/37.0
SUPPLY 0V									-XG	31				=100-S1	14				=100/37.1
=										31									=100/37.1
=										31									=100/37.1
RELEASE									=100-K1	85				=100-K2	85				=100/37.6
DIAGNOSTIC									-X1	31				=100-B1	-				=100/39.6
									=100-X	2				-X1	31				=100/39.6
START								2	-XG	50				-U1	32				=100/37.4
DYNAMO								1	-XG	61				=100-D+					=100/37.3

DATE	06.Mai.2013	<b>KLEEMANN GMBH</b>		<b>KLEMMENLEISTE +M-XG/ TERMINAL STRIP +M-XG</b>	KLEEMANN SERIES	<b>K007</b>	<b>= KLE</b>		
EDITED	PC1	<b>MOBICAT MC 120 Z EU</b>				KLEEMANN MATERIAL NO	<b>2315434</b>	CAE-SYSTEM: EPLAN 5.70	PG.
CONTR.	D. MALLKOWSKY							PG.	<b>36</b>
ORIGIN		REP.F.	REP.T.						

FUNCTION TEXT	CABLE DESIGNATION/TYPE	TERMINAL STRIP/PLUG -XOUT										CABLE DESIGNATION/TYPE	PAGE/ PATH	
		DESIGNATION OF EXTERNAL DESTINATION	CONNECTION	NO.	BRIDGE FIXED	INTERNAL WIRING	PLC DESIGNATION	DESIGNATION OF INTERNAL DESTINATION	CONNECTION					
E-STOP SWITCHGEAR						=100-D1	13							=100/6.1.5
=						=100-D1	14							=100/6.1.5
OVERLOAD REMOVAL						-A0_5	27							=100/31.7
=						=100-GK26	11							
						-A0_5	34			E7.6				=100/31.7
LOCKING CONVEYOR BELT 2						=100-8K04	11							
=						-A0_4	35			E3.0	-XOUT	12		=100/27.1
						-A0_4	28							
										E3.0	-XOUT	11		=100/27.1
E-STOP SWITCHGEAR						-XOUT	14				=100-KGA1	14		=100/6.1.1
=						-XOUT	13				=100-D1	S12		=100/6.1.1
						-XOUT	16				=100-KGA1	44		=100/6.1.1
=						-XOUT	15				=100-D1	S52		=100/6.1.1

		DATE	06.Mai.2013		KLEEMANN GMBH		<b>kleemann</b>		STECKER -XOUT/ PLUG -XOUT		KLEEMANN SERIES		K007	= KLE	+
		EDITED	PC1		MOBICAT MC 120 Z EU						KLEEMANN MATERIAL NO		2315434	CAE-SYSTEM: EPLAN 5.70	PG.
MODIFICAT.	DATE	NAME	NORM	DIN	ORIGIN	REP.F.	REP.T.					PG.	36		

0 1 2 3 4 5 6 7 8 9

FUNCTION TEXT	CABLE DESIGNATION/TYPE	DESIGNATION OF EXTERNAL DESTINATION	CONNECTION	NO.	FIXED	BRIDGE	INTERNAL WIRING	PLC DESIGNATION	DESIGNATION OF INTERNAL DESTINATION	CONNECTION	CABLE DESIGNATION/TYPE	PAGE/PATH
E-STOP PUSH-BUTTON		-X0	19	1					-3X2	2		=100/6.4
=		-4X2		1	2				-3X2	1		=100/6.4
=		-X0	20	3					-3X2	4		=100/6.4
=		-4X2	3	4					-3X2	3		=100/6.4

29

31

DATE	06.Mai.2013	KLEEMANN GMBH				 <b>STECKER -3X2/ PLUG -3X2</b>	KLEEMANN SERIES	K007	= KLE	+
EDITED	PC1	MOBICAT MC 120 Z EU					KLEEMANN MATERIAL NO	2315434	CAE-SYSTEM: EPLAN 5.70	PG. 30
CONTR.	D. MALLKOWSKY	ORIGIN	REP.F.	REP.T.					PG. 36	
MODIFICAT.	DATE	NAME	NORM	DIN						



0	1	2	3	4	5	6	7	8	9						
FUNCTION TEXT						CABLE DESIGNATION/TYP	TERMINAL STRIP/PLUG -4X1				CABLE DESIGNATION/TYP	PAGE/ PATH			
						-11W1 H07RN-F	4G6	DESIGNATION OF EXTERNAL DESTINATION	CONNECTION	NO.	BRIDGE		DESIGNATION OF INTERNAL DESTINATION	CONNECTION	
											FIXED	INTERNAL WIRING			PLC DESIG- NATION
CONVEYOR BELT 4								BK =100+M-4M1	U	1			=100-4F1	2	=100/11.1
=								BN =100+M-4M1	V	2			=100-4F1	4	=100/11.1
=								GY =100+M-4M1	W	3			=100-4F1	6	=100/11.1
=										4					
=										5					=100/11.2
=										6					=100/11.2
=										PE					
=								GYNE =100+M-4M1	PE	PE			=100-PE		=100/11.2

FUNCTION TEXT	CABLE DESIGNATION/TYP	5G1	TERMINAL STRIP/PLUG					-4X2	CONNECTION	CABLE DESIGNATION/TYP	PAGE/PATH	
			DESIGNATION OF EXTERNAL DESTINATION	CONNECTION	NO.	BRIDGE						DESIGNATION OF INTERNAL DESTINATION
						INTERNAL WIRING	PLC DESIGNATION					
E-STOP PUSH-BUTTON		1	=100+M-0S08	22	1				-3X2	2	=100/6.5	
=		2	=100+M-0S08	21	2				-X3	1	=100/6.5	
=		3	=100+M-0S08	12	3				-3X2	4	=100/6.6	
=		4	=100+M-0S08	11	4				-X3	3	=100/6.6	

31

33

MODIFICAT.	DATE	NAME	NORM	DIN	ORIGIN	REP.F.	REP.T.	STECKER -4X2/ PLUG -4X2	KLEEMANN SERIES K007 KLEEMANN MATERIAL NO 2315434	= KLE CAE-SYSTEM: EPLAN 5.70	+ PG. 32 PG. 36
					KLEEMANN GMBH						
					MOBICAT MC 120 Z EU						



FUNCTION TEXT		CABLE DESIGNATION/TYP	TERMINAL STRIP/PLUG +M-XF1															CABLE DESIGNATION/TYP		PAGE/ PATH
DESIGNATION OF EXTERNAL DESTINATION	CONNECTION	NO.	BRIDGE		PLC DESIG- NATION	DESIGNATION OF INTERNAL DESTINATION	CONNECTION	-41W4 OEFLEX 110	7G1.5	CABLE DESIGNATION/TYP	PAGE/ PATH									
			F I X E D	INTERNAL WIRING																
EINSPEISUNG 24V DC						=100-20A3	+	1			-X22	1	1			=100/41.7				
EINSPEISUNG 0V DC						=100-20A3	6	2			-X22	2	2			=100/41.9				
RUN CHAIN LEFT (MANUAL)						=100-20A3	2	3			-X22	B2	3			=100/41.8				
=						=100-20A3	3	4			-X22	A2	4			=100/41.8				
RUN CHAIN RIGHT (MANUAL)						=100-20A3	4	5			-X22	B1	5			=100/41.7				
=						=100-20A3	5	6			-X22	A1	6			=100/41.7				

FUNCTION TEXT				CABLE DESIGNATION/TYPE				5G1				<b>TERMINAL STRIP/PLUG</b>				5G1				CABLE DESIGNATION/TYPE	PAGE/ PATH
FUNCTION TEXT				CABLE DESIGNATION/TYPE				5G1	DESIGNATION OF EXTERNAL DESTINATION		CONNECTION	NO.	BRIDGE		PLC DESIGNATION	DESIGNATION OF INTERNAL DESTINATION		CONNECTION	5G1	CABLE DESIGNATION/TYPE	PAGE/ PATH
									DESIGNATION OF EXTERNAL DESTINATION		CONNECTION	NO.	FIXED	INTERNAL WIRING	PLC DESIGNATION	DESIGNATION OF INTERNAL DESTINATION		CONNECTION			
E-STOP PUSH-BUTTON								1	=100-0S02	21	1				-X0	3	1		=100/6.1		
=								2	=100-0S02	22	2				-X0	5	2		=100/6.1		
=								3	=100-0S02	11	3				-X0	4	3		=100/6.1		
=								4	=100-0S02	12	4				-X0	6	4		=100/6.1		

DATE	06.Mai.2013	KLEEMANN GMBH	 <b>kleemann</b>	STECKER +M-XS2/ PLUG +M-XS2	KLEEMANN SERIES	K007	= KLE	+
EDITED	PC1	MOBICAT MC 120 Z EU				KLEEMANN MATERIAL NO	2315434	CAE-SYSTEM: EPLAN 5.70
CONTR.	D. MALLKOWSKY							PG. 36
MODIFICAT.	DATE	NAME	NORM	DIN	ORIGIN	REP.F.	REP.T.	

FUNCTION TEXT	CABLE DESIGNATION/TYP	TERMINAL STRIP/PLUG													CABLE DESIGNATION/TYP	PAGE/ PATH
		+M-XS5														
		-06W15 OEFLEX 540P	DESIGNATION OF EXTERNAL DESTINATION	CONNECTION	NO.	BRIDGE		PLC DESIG- NATION	DESIGNATION OF INTERNAL DESTINATION	CONNECTION	-06W5 OEFLEX 540P	5G1				
F I X E D	INTERNAL WIRING															
E-STOP PUSH-BUTTON		2	=100-0S05	22	1				-X0	11	2		=100/6.2			
=		1	=100-0S05	21	2				-X0	9	1		=100/6.2			
=		4	=100-0S05	12	3				-X0	12	4		=100/6.2			
=		3	=100-0S05	11	4				-X0	10	3		=100/6.2			

34 36

DATE	06.Mai.2013	KLEEMANN GMBH		 	STECKER +M-XS5/ PLUG +M-XS5	KLEEMANN SERIES	K007	= KLE	+
EDITED	PC1	MOBICAT MC 120 Z EU				KLEEMANN MATERIAL NO	2315434	CAE-SYSTEM: EPLAN 5.70	PG.
CONTR.	D. MALLKOWSKY	ORIGIN	REP.F.	REP.T.				PG.	36

FUNCTION TEXT	CABLE DESIGNATION/TYP								4G1.5	TERMINAL STRIP/PLUG +M-6X1								4G1.5	CABLE DESIGNATION/TYP	PAGE/ PATH		
										DESIGNATION OF EXTERNAL DESTINATION	CONNECTION	NO.	BRIDGE		PLC DESIGNATION	DESIGNATION OF INTERNAL DESTINATION	CONNECTION					
													FIXED	INTERNAL WIRING								
CONVEYOR BELT 6										BK	=100-6M1	U	1					-X1	14	BK	=100/12.1	
=										BN	=100-6M1	V	2					-X1	15	BN	=100/12.1	
=										GY	=100-6M1	W	3					-X1	16	GY	=100/12.1	
=										GNYE	=100-6M1	PE		PE				-X1	PE	GNYE	=100/12.2	

# Cable overview

TPS\_PST2 15.04.2003

Cable id	Cable name	Source from	Target to	Cable type	Total Cores	used Cores	Cross section mm <sup>2</sup>	Length m	Remark	Graphics Page
-03W1				H07RN-F	5	4	1.5	-		/10
		-0X06	=100+M-E1		5	2	1.5			/10
		-0X07	=100+M-E2		5	2	1.5			/10
-03W2		-0X0	=100+M-B1	H07RN-F	3	3G	1.5	-		/11
-06W1		-X0	=100+M-0S01	OELFLEX 540P	5G	4	1	-		/12
-06W2		-X0	+M-XS2	OELFLEX 540P	5G	4	1	-		/13
-06W3		-X0	=100+M-0S03	OELFLEX 540P	5G	4	1	-		/14
-06W4		-X0	=100+M-0S04	OELFLEX 540P	5G	4	1	-		/15
-06W5		-X0	+M-XS5	OELFLEX 540P	5G	4	1	-		/16
-06W6		-X0	=100+M-0S06	OELFLEX 540P	5G	4	1	-		/17
-06W7		-X0	=100+M-0S07	OELFLEX 540P	5G	4	1	-		/18
-06W8		-4X2	=100+M-0S08	OELFLEX 540P	5G	4	1	-		/19
-07W1		-XK	=100+M-Y10	OELFLEX 110	3G	2	1.5	-		/22
-07W2		-X6	=100+M-00H2	OELFLEX 110	3G	2	0.75	-		/23
-07W3		-X6	=100+M-00H3	OELFLEX 110	3G	2	0.75	-		/24
-10W1		-X1	=100+M-2M1	H07RN-F	4	4G	1.5	-		/25
-10W2		-X1	=100+M-2Y1	H07RN-F	5	5G	4	-		/26
-10W3		=100-3X2	=100+M-3M1	H07RN-F	4	4	1.5	-		/27
-11W1		-4X1	=100+M-4M1	H07RN-F	4	4G	6	-		/28
-11W2		-X1	=100+M-5M1	H07RN-F	4	4G	1	-		/29
-11W3		-X1	=100+M-5M2	H07RN-F	4	4G	1.5	-		/30
-12W1		-X1	+M-6X1	H07RN-F	4	4G	1.5	-		/31
-12W2		+M-6X1	=100+M-6M1	H07RN-F	4	4G	1.5	-		/32
-12W3		-X1	=100+M-6X2	H07RN-F	4	4G	1.5	-		/33
-12W4		-X1	=100+M-7M1	H07RN-F	4	4G	6	-		/34
-13W1		-X1	=100+M-9M1	H07RN-F	4	4G	1.5	-		/35
-13W2		-X1	=100+M-WP	H07RN-F	3	3G	1.5	-		/36
-13W3		-X1	=100+M-13M1	H07RN-F	4	4G	1.5	-		/37
-14W1		-X8	=100+M-8M1	OELFLEX FD855CP	4G+Schirm	4G	2.5	-		/38
-14W2		-X8	=100+M-8M2	OELFLEX FD855CP	4G+Schirm	4G	2.5	-		/39
-36W1		-XLS	=100+M-LR	UNITRONIC	3+Schirm	2	0.5	-		/40
-36W2		-XLS	=100+M-LT	UNITRONIC	3+Schirm	2	0.5	-		/41
-37W1		-XG	+M-XG	H07RN-F	4	2	4	-		/42
-37W2		-XG	+M-XG	OELFLEX 110	18G	10	1	-		/43
-41W1		-XF	=100+M-20A2	H07RN-F	19G	14	1.5	-		/44

=KLE/36

2

DATE		13.Mai.2013		KLEEMANN GMBH		  KABELUEBERSICHT/ CABLE SURVEY		KLEEMANN SERIES		K007		= KAB		+	
EDITED		PC1		MOBICAT MC 120 Z EU				KLEEMANN MATERIAL NO		2315434		CAE-SYSTEM: EPLAN 5.70		PG. 1	
MODIFICAT.	DATE	NAME	NORM	DIN	ORIGIN	REP.F.	REP.T.					PG. 48			





INTERCONNECTION DIAGRAM

TPS\_N\_20.SKN / 2005-07-25

CABLE NAME	-03W1	CABLE TYPE	H07RN-F
------------	-------	------------	---------

REMARK		NO. OF CORES	5	CROSS SECTION	1.5	CABLE LENGTH	-
--------	--	--------------	---	---------------	-----	--------------	---

FUNCTION TEXT	PAGE/PATH	DESTINATION DESIGNATION FROM	CONNECTION	CORE	DESTINATION DESIGNATION TO	CONNECTION	PAGE/PATH	FUNCTION TEXT
				GNYE				
ILLUMINATION 2	=100/3.3	-0X07	2	BU	=100+M-E2	X2	=100/3.3	ILLUMINATION 2
ILLUMINATION 1	=100/3.1	-0X06	2	BN	=100+M-E1	X2	=100/3.1	ILLUMINATION 1
ILLUMINATION 1	=100/3.1	-0X06	1	BK	=100+M-E1	X1	=100/3.1	ILLUMINATION 1
ILLUMINATION 2	=100/3.3	-0X07	1	GY	=100+M-E2	X1	=100/3.3	ILLUMINATION 2

2		DATE	06.Mai.2013	KLEEMANN GMBH			 	-03W1	KLEEMANN SERIES	K007	= KAB	+
		EDITED	PC1	MOBICAT MC 120 Z EU					KLEEMANN MATERIAL NO	2315434	CAE-SYSTEM: EPLAN 5.70	PG. 10
MODIFICAT.	DATE	NAME	NORM	DIN	ORIGIN	REP.F.	REP.T.				PG. 48	

INTERCONNECTION DIAGRAM

TPS\_N\_20.SKN / 2005-07-25

CABLE NAME -03W2 CABLE TYPE H07RN-F

REMARK NO. OF CORES 3 CROSS SECTION 1.5 CABLE LENGTH -

FUNCTION TEXT	PAGE/PATH	DESTINATION DESIGNATION FROM	CONNECTION	CORE	DESTINATION DESIGNATION TO	CONNECTION	PAGE/PATH	FUNCTION TEXT
BELT WEIGHER	=100/3.5	-0X0	PE	GNYE	=100+M-B1	PE	=100/3.5	ILLUMINATION 2
BELT WEIGHER	=100/3.5	-0X0	2	BU	=100+M-B1	2	=100/3.5	ILLUMINATION 2
BELT WEIGHER	=100/3.5	-0X0	1	BN	=100+M-B1	1	=100/3.5	ILLUMINATION 2

INTERCONNECTION DIAGRAM

TPS\_N\_20.SKN / 2005-07-25

CABLE NAME				CABLE TYPE					
-06W1				OELFLEX 540P					
REMARK				NO. OF CORES		CROSS SECTION		CABLE LENGTH	
				5G		1		-	
FUNCTION TEXT	PAGE/PATH	DESTINATION DESIGNATION FROM	CONNECTION	CORE	DESTINATION DESIGNATION TO	CONNECTION	PAGE/PATH	FUNCTION TEXT	
E-STOP PUSH-BUTTON	=100/6.0	-X0	1	1	=100+M-0S01	21	=100/6.0	E-STOP PUSH-BUTTON	
E-STOP PUSH-BUTTON	=100/6.0	-X0	3	2	=100+M-0S01	22	=100/6.0	E-STOP PUSH-BUTTON	
E-STOP PUSH-BUTTON	=100/6.1	-X0	2	3	=100+M-0S01	11	=100/6.1	E-STOP PUSH-BUTTON	
E-STOP PUSH-BUTTON	=100/6.1	-X0	4	4	=100+M-0S01	12	=100/6.1	E-STOP PUSH-BUTTON	
				PE					

**INTERCONNECTION DIAGRAM**

TPS\_N\_20.SKN / 2005-07-25

CABLE NAME <b>-06W2</b>	CABLE TYPE <b>OELFLEX 540P</b>
-------------------------	--------------------------------

REMARK	NO. OF CORES <b>5G</b>	CROSS SECTION <b>1</b>	CABLE LENGTH <b>-</b>
--------	------------------------	------------------------	-----------------------

FUNCTION TEXT	PAGE/PATH	DESTINATION DESIGNATION FROM	CONNECTION	CORE	DESTINATION DESIGNATION TO	CONNECTION	PAGE/PATH	FUNCTION TEXT
E-STOP PUSH-BUTTON	=100/6.0	-X0	3	1	+M-XS2	1	=100/6.1	E-STOP PUSH-BUTTON
E-STOP PUSH-BUTTON	=100/6.0	-X0	5	2	+M-XS2	2	=100/6.1	E-STOP PUSH-BUTTON
E-STOP PUSH-BUTTON	=100/6.1	-X0	4	3	+M-XS2	3	=100/6.1	E-STOP PUSH-BUTTON
E-STOP PUSH-BUTTON	=100/6.1	-X0	6	4	+M-XS2	4	=100/6.1	E-STOP PUSH-BUTTON
				PE				

**INTERCONNECTION DIAGRAM**

TPS\_N\_20.SKN / 2005-07-25

CABLE NAME <b>-06W3</b>					CABLE TYPE <b>OELFLEX 540P</b>				
-------------------------	--	--	--	--	--------------------------------	--	--	--	--

REMARK					NO. OF CORES <b>5G</b>		CROSS SECTION <b>1</b>		CABLE LENGTH <b>-</b>	
--------	--	--	--	--	------------------------	--	------------------------	--	-----------------------	--

FUNCTION TEXT	PAGE/PATH	DESTINATION DESIGNATION FROM	CONNECTION	CORE	DESTINATION DESIGNATION TO	CONNECTION	PAGE/PATH	FUNCTION TEXT
E-STOP PUSH-BUTTON	=100/6.0	-X0	5	1	=100+M-0S03	21	=100/6.0	E-STOP PUSH-BUTTON
E-STOP PUSH-BUTTON	=100/6.0	-X0	7	2	=100+M-0S03	22	=100/6.0	E-STOP PUSH-BUTTON
E-STOP PUSH-BUTTON	=100/6.1	-X0	6	3	=100+M-0S03	11	=100/6.1	E-STOP PUSH-BUTTON
E-STOP PUSH-BUTTON	=100/6.1	-X0	8	4	=100+M-0S03	12	=100/6.1	E-STOP PUSH-BUTTON
				PE				

**INTERCONNECTION DIAGRAM**

TPS\_N\_20.SKN / 2005-07-25

CABLE NAME					CABLE TYPE					
-06W4					OELFLEX 540P					
REMARK					NO. OF CORES		CROSS SECTION		CABLE LENGTH	
					5G		1		-	
FUNCTION TEXT	PAGE/PATH	DESTINATION DESIGNATION FROM	CONNECTION	CORE	DESTINATION DESIGNATION TO	CONNECTION	PAGE/PATH	FUNCTION TEXT		
E-STOP PUSH-BUTTON	=100/6.0	-X0	7	1	=100+M-0S04	21	=100/6.2	E-STOP PUSH-BUTTON		
E-STOP PUSH-BUTTON	=100/6.2	-X0	9	2	=100+M-0S04	22	=100/6.2	E-STOP PUSH-BUTTON		
E-STOP PUSH-BUTTON	=100/6.1	-X0	8	3	=100+M-0S04	11	=100/6.3	E-STOP PUSH-BUTTON		
E-STOP PUSH-BUTTON	=100/6.2	-X0	10	4	=100+M-0S04	12	=100/6.3	E-STOP PUSH-BUTTON		
				PE						

**INTERCONNECTION DIAGRAM**

TPS\_N\_20.SKN / 2005-07-25

CABLE NAME	<b>-06W5</b>	CABLE TYPE	<b>OELFLEX 540P</b>
------------	--------------	------------	---------------------

REMARK		NO. OF CORES	<b>5G</b>	CROSS SECTION	<b>1</b>	CABLE LENGTH	<b>-</b>
--------	--	--------------	-----------	---------------	----------	--------------	----------

FUNCTION TEXT	PAGE/PATH	DESTINATION DESIGNATION FROM	CONNECTION	CORE	DESTINATION DESIGNATION TO	CONNECTION	PAGE/PATH	FUNCTION TEXT
E-STOP PUSH-BUTTON	=100/6.2	-X0	9	1	+M-XS5	2	=100/6.2	E-STOP PUSH-BUTTON
E-STOP PUSH-BUTTON	=100/6.2	-X0	11	2	+M-XS5	1	=100/6.2	E-STOP PUSH-BUTTON
E-STOP PUSH-BUTTON	=100/6.2	-X0	10	3	+M-XS5	4	=100/6.2	E-STOP PUSH-BUTTON
E-STOP PUSH-BUTTON	=100/6.2	-X0	12	4	+M-XS5	3	=100/6.2	E-STOP PUSH-BUTTON
				PE				

DATE		06.Mai.2013		KLEEMANN GMBH			-06W5		KLEEMANN SERIES K007		= KAB		+	
EDITED		PC1		MOBICAT MC 120 Z EU					KLEEMANN MATERIAL NO 2315434		CAE-SYSTEM: EPLAN 5.70		PG. 16	
MODIFICAT.	DATE	NAME	NORM	DIN	ORIGIN	REP.F.	REP.T.					PG. 48		

INTERCONNECTION DIAGRAM TPS\_N\_20.SKN / 2005-07-25

CABLE NAME <b>-06W6</b>					CABLE TYPE <b>OELFLEX 540P</b>				
REMARK					NO. OF CORES <b>5G</b>		CROSS SECTION <b>1</b>		CABLE LENGTH <b>-</b>
FUNCTION TEXT	PAGE/PATH	DESTINATION DESIGNATION FROM	CONNECTION	CORE	DESTINATION DESIGNATION TO	CONNECTION	PAGE/PATH	FUNCTION TEXT	
E-STOP PUSH-BUTTON	=100/6.2	-X0	11	1	=100+M-0S06	21	=100/6.3	E-STOP PUSH-BUTTON	
E-STOP PUSH-BUTTON	=100/6.3	-X0	13	2	=100+M-0S06	22	=100/6.3	E-STOP PUSH-BUTTON	
E-STOP PUSH-BUTTON	=100/6.2	-X0	12	3	=100+M-0S06	11	=100/6.4	E-STOP PUSH-BUTTON	
E-STOP PUSH-BUTTON	=100/6.4	-X0	14	4	=100+M-0S06	12	=100/6.4	E-STOP PUSH-BUTTON	
				PE					



# INTERCONNECTION DIAGRAM

TPS\_N\_20.SKN / 2005-07-25

CABLE NAME <b>-06W7</b>					CABLE TYPE <b>OELFLEX 540P</b>					
REMARK					NO. OF CORES <b>5G</b>		CROSS SECTION <b>1</b>		CABLE LENGTH <b>-</b>	
FUNCTION TEXT	PAGE/PATH	DESTINATION DESIGNATION FROM	CONNECTION	CORE	DESTINATION DESIGNATION TO	CONNECTION	PAGE/PATH	FUNCTION TEXT		
E-STOP PUSH-BUTTON	=100/6.3	-X0	13	1	=100+M-0S07	21	=100/6.4	E-STOP PUSH-BUTTON		
E-STOP PUSH-BUTTON	=100/6.4	-X0	15	2	=100+M-0S07	22	=100/6.4	E-STOP PUSH-BUTTON		
E-STOP PUSH-BUTTON	=100/6.4	-X0	14	3	=100+M-0S07	11	=100/6.4	E-STOP PUSH-BUTTON		
E-STOP PUSH-BUTTON	=100/6.4	-X0	16	4	=100+M-0S07	12	=100/6.4	E-STOP PUSH-BUTTON		
				PE						

# INTERCONNECTION DIAGRAM

TPS\_N\_20.SKN / 2005-07-25

CABLE NAME <b>-06W8</b>	CABLE TYPE <b>OELFLEX 540P</b>
-------------------------	--------------------------------

REMARK	NO. OF CORES <b>5G</b>	CROSS SECTION <b>1</b>	CABLE LENGTH <b>-</b>
--------	------------------------	------------------------	-----------------------

FUNCTION TEXT	PAGE/PATH	DESTINATION DESIGNATION FROM	CONNECTION	CORE	DESTINATION DESIGNATION TO	CONNECTION	PAGE/PATH	FUNCTION TEXT
E-STOP PUSH-BUTTON	=100/6.5	-4X2	1	1	=100+M-0S08	22	=100/6.5	E-STOP PUSH-BUTTON
E-STOP PUSH-BUTTON	=100/6.5	-4X2	2	2	=100+M-0S08	21	=100/6.5	E-STOP PUSH-BUTTON
E-STOP PUSH-BUTTON	=100/6.6	-4X2	3	3	=100+M-0S08	12	=100/6.6	E-STOP PUSH-BUTTON
E-STOP PUSH-BUTTON	=100/6.6	-4X2	4	4	=100+M-0S08	11	=100/6.6	E-STOP PUSH-BUTTON
				PE				

DATE: 06.Mai.2013		KLEEMANN GMBH			-06W8		KLEEMANN SERIES <b>K007</b>	= <b>KAB</b>		+
EDITED: PC1		MOBICAT MC 120 Z EU			KLEEMANN MATERIAL NO <b>2315434</b>		CAE-SYSTEM: EPLAN 5.70	PG. 19		PG. 48
MODIFICAT.	DATE	NAME	NORM	DIN	ORIGIN	REP.F.	REP.T.			

INTERCONNECTION DIAGRAM TPS\_N\_20.SKN / 2005-07-25

CABLE NAME <b>-06W12</b>				CABLE TYPE <b>OELFLEX 540P</b>					
REMARK				NO. OF CORES <b>5G</b>		CROSS SECTION <b>1</b>		CABLE LENGTH <b>-</b>	
FUNCTION TEXT	PAGE/PATH	DESTINATION DESIGNATION FROM	CONNECTION	CORE	DESTINATION DESIGNATION TO	CONNECTION	PAGE/PATH	FUNCTION TEXT	
E-STOP PUSH-BUTTON	=100/6.1	+M-XS2	1	1	=100+M-0S02	21	=100/6.1	E-STOP PUSH-BUTTON	
E-STOP PUSH-BUTTON	=100/6.1	+M-XS2	2	2	=100+M-0S02	22	=100/6.1	E-STOP PUSH-BUTTON	
E-STOP PUSH-BUTTON	=100/6.1	+M-XS2	3	3	=100+M-0S02	11	=100/6.1	E-STOP PUSH-BUTTON	
E-STOP PUSH-BUTTON	=100/6.1	+M-XS2	4	4	=100+M-0S02	12	=100/6.1	E-STOP PUSH-BUTTON	
				PE					

**INTERCONNECTION DIAGRAM**

TPS\_N\_20.SKN / 2005-07-25

CABLE NAME <b>-06W15</b>	CABLE TYPE <b>OELFLEX 540P</b>
--------------------------	--------------------------------

REMARK	NO. OF CORES <b>5G</b>	CROSS SECTION <b>1</b>	CABLE LENGTH <b>-</b>
--------	------------------------	------------------------	-----------------------

FUNCTION TEXT	PAGE/PATH	DESTINATION DESIGNATION FROM	CONNECTION	CORE	DESTINATION DESIGNATION TO	CONNECTION	PAGE/PATH	FUNCTION TEXT
E-STOP PUSH-BUTTON	=100/6.2	+M-XS5	2	1	=100+M-0S05	21	=100/6.2	E-STOP PUSH-BUTTON
E-STOP PUSH-BUTTON	=100/6.2	+M-XS5	1	2	=100+M-0S05	22	=100/6.2	E-STOP PUSH-BUTTON
E-STOP PUSH-BUTTON	=100/6.2	+M-XS5	4	3	=100+M-0S05	11	=100/6.2	E-STOP PUSH-BUTTON
E-STOP PUSH-BUTTON	=100/6.2	+M-XS5	3	4	=100+M-0S05	12	=100/6.2	E-STOP PUSH-BUTTON
				PE				

20		DATE 06.Mai.2013	KLEEMANN GMBH		-06W15	KLEEMANN SERIES <b>K007</b>	= <b>KAB</b>	+	22
		EDITED PC1	MOBICAT MC 120 Z EU						
		CONTR. D. MALLKOWSKY							
MODIFICAT.	DATE	NAME	NORM	DIN	ORIGIN	REP.F.	REP.T.	CAE-SYSTEM: EPLAN 5.70	PG. 21
								<b>2315434</b>	PG. 48



# INTERCONNECTION DIAGRAM

TPS\_N\_20.SKN / 2005-07-25

CABLE NAME -07W2						CABLE TYPE OELFLEX 110				
REMARK						NO. OF CORES 3G		CROSS SECTION 0.75		CABLE LENGTH -
FUNCTION TEXT	PAGE/PATH	DESTINATION DESIGNATION FROM	CONNECTION	CORE	DESTINATION DESIGNATION TO	CONNECTION	PAGE/PATH	FUNCTION TEXT		
HOOTER	=100/7.6	-X6	1	1	=100+M-00H2	1	=100/7.6	HOOTER		
HOOTER	=100/7.6	-X6	2	2	=100+M-00H2	2	=100/7.6	HOOTER		
				3						

22

24

DATE		06.Mai.2013		KLEEMANN GMBH		 	-07W2		KLEEMANN SERIES K007		= KAB		+	
EDITED		PC1		MOBICAT MC 120 Z EU			KLEEMANN MATERIAL NO 2315434		CAE-SYSTEM: EPLAN 5.70		PG. 23			
CONTR.		D. MALLKOWSKY		ORIGIN	REP.F.	REP.T.					PG. 48			

### INTERCONNECTION DIAGRAM

TPS\_N\_20.SKN / 2005-07-25

CABLE NAME				-07W3						CABLE TYPE				OELFLEX 110													
REMARK				NO. OF CORES				3G				CROSS SECTION				0.75				CABLE LENGTH				-			
FUNCTION TEXT	PAGE/PATH	DESTINATION DESIGNATION FROM	CONNECTION	CORE	DESTINATION DESIGNATION TO	CONNECTION	PAGE/PATH	FUNCTION TEXT																			
FLASHING LIGHT	=100/7.8	-X6	3	1	=100+M-00H3	X1	=100/7.8	FLASHING LIGHT																			
FLASHING LIGHT	=100/7.8	-X6	4	2	=100+M-00H3	X2	=100/7.8	FLASHING LIGHT																			
				3																							

**INTERCONNECTION DIAGRAM**

TPS\_N\_20.SKN / 2005-07-25

CABLE NAME					-10W1					CABLE TYPE					H07RN-F																			
REMARK					NO. OF CORES					4					CROSS SECTION					1.5					CABLE LENGTH					-				
FUNCTION TEXT		PAGE/PATH		DESTINATION DESIGNATION FROM		CONNECTION	CORE	DESTINATION DESIGNATION TO		CONNECTION	PAGE/PATH		FUNCTION TEXT																					
MAGNETIC BELT 2		=100/10.2		-X1		PE	GNYE	=100+M-2M1		PE	=100/10.1		MAGNETIC BELT 2																					
MAGNETIC BELT 2		=100/10.1		-X1		2	BN	=100+M-2M1		V	=100/10.1		MAGNETIC BELT 2																					
MAGNETIC BELT 2		=100/10.1		-X1		1	BK	=100+M-2M1		U	=100/10.1		MAGNETIC BELT 2																					
MAGNETIC BELT 2		=100/10.1		-X1		3	GY	=100+M-2M1		W	=100/10.1		MAGNETIC BELT 2																					



INTERCONNECTION DIAGRAM TPS\_N\_20.SKN / 2005-07-25

CABLE NAME <b>-10W2</b>				CABLE TYPE <b>H07RN-F</b>				
REMARK				NO. OF CORES <b>5</b>		CROSS SECTION <b>4</b>		CABLE LENGTH <b>-</b>
FUNCTION TEXT	PAGE/PATH	DESTINATION DESIGNATION FROM	CONNECTION	CORE	DESTINATION DESIGNATION TO	CONNECTION	PAGE/PATH	FUNCTION TEXT
MAGNET	=100/10.5	-X1	PE	GNYE	=100+M-2Y1	PE	=100/10.4	MAGNETIC BELT 2
MAGNET	=100/10.4	-X1	7	BU	=100+M-2Y1	N	=100/10.4	MAGNETIC BELT 2
MAGNET	=100/10.4	-X1	5	BN	=100+M-2Y1	L2	=100/10.4	MAGNETIC BELT 2
MAGNET	=100/10.4	-X1	4	BK	=100+M-2Y1	L1	=100/10.4	MAGNETIC BELT 2
MAGNET	=100/10.4	-X1	6	GY	=100+M-2Y1	L3	=100/10.4	MAGNETIC BELT 2

# INTERCONNECTION DIAGRAM

TPS\_N\_20.SKN / 2005-07-25

CABLE NAME -10W3				CABLE TYPE H07RN-F					
REMARK				NO. OF CORES 4		CROSS SECTION 1.5		CABLE LENGTH -	
FUNCTION TEXT	PAGE/PATH	DESTINATION DESIGNATION FROM	CONNECTION	CORE	DESTINATION DESIGNATION TO	CONNECTION	PAGE/PATH	FUNCTION TEXT	
CONVEYOR BELT 3	=100/10.8	=100-3X2	PE	GNYE	=100+M-3M1	PE	=100/10.7	CONVEYOR BELT 3	
CONVEYOR BELT 3	=100/10.7	=100-3X2	2	BN	=100+M-3M1	V	=100/10.7	CONVEYOR BELT 3	
CONVEYOR BELT 3	=100/10.7	=100-3X2	1	BK	=100+M-3M1	U	=100/10.7	CONVEYOR BELT 3	
CONVEYOR BELT 3	=100/10.7	=100-3X2	3	GY	=100+M-3M1	W	=100/10.7	CONVEYOR BELT 3	

**INTERCONNECTION DIAGRAM**

CABLE NAME -11W1				CABLE TYPE H07RN-F					
REMARK				NO. OF CORES 4		CROSS SECTION 6		CABLE LENGTH -	
FUNCTION TEXT	PAGE/PATH	DESTINATION DESIGNATION FROM	CONNECTION	CORE	DESTINATION DESIGNATION TO	CONNECTION	PAGE/PATH	FUNCTION TEXT	
CONVEYOR BELT 4	=100/11.2	-4X1	PE	GNYE	=100+M-4M1	PE	=100/11.1	CONVEYOR BELT 4	
CONVEYOR BELT 4	=100/11.1	-4X1	2	BN	=100+M-4M1	V	=100/11.1	CONVEYOR BELT 4	
CONVEYOR BELT 4	=100/11.1	-4X1	1	BK	=100+M-4M1	U	=100/11.1	CONVEYOR BELT 4	
CONVEYOR BELT 4	=100/11.1	-4X1	3	GY	=100+M-4M1	W	=100/11.1	CONVEYOR BELT 4	

INTERCONNECTION DIAGRAM

TPS\_N\_20.SKN / 2005-07-25

CABLE NAME -11W2				CABLE TYPE H07RN-F				
REMARK				NO. OF CORES 4		CROSS SECTION 1		CABLE LENGTH -
FUNCTION TEXT	PAGE/PATH	DESTINATION DESIGNATION FROM	CONNECTION	CORE	DESTINATION DESIGNATION TO	CONNECTION	PAGE/PATH	FUNCTION TEXT
VIBRATING CHUTE/CRUSHER 5	=100/11.5	-X1	PE	GNYE	=100+M-5M1	PE	=100/11.4	VIBRATING CHUTE/CRUSHER 5
VIBRATING CHUTE/CRUSHER 5	=100/11.4	-X1	9	BN	=100+M-5M1	V	=100/11.4	VIBRATING CHUTE/CRUSHER 5
VIBRATING CHUTE/CRUSHER 5	=100/11.4	-X1	8	BK	=100+M-5M1	U	=100/11.4	VIBRATING CHUTE/CRUSHER 5
VIBRATING CHUTE/CRUSHER 5	=100/11.4	-X1	10	GY	=100+M-5M1	W	=100/11.4	VIBRATING CHUTE/CRUSHER 5

28		DATE 06.Mai.2013		KLEEMANN GMBH		 KLEEMANN	-11W2	KLEEMANN SERIES K007		= KAB	+
		EDITED PC1		MOBICAT MC 120 Z EU				KLEEMANN MATERIAL NO 2315434		CAE-SYSTEM: EPLAN 5.70	PG. 29
MODIFICAT.	DATE	NAME	NORM	DIN	ORIGIN	REP.F.	REP.T.			PG. 48	



# INTERCONNECTION DIAGRAM

TPS\_N\_20.SKN / 2005-07-25

CABLE NAME <b>-12W1</b>			CABLE TYPE <b>H07RN-F</b>						
REMARK			NO. OF CORES <b>4</b>		CROSS SECTION <b>1.5</b>		CABLE LENGTH <b>-</b>		
FUNCTION TEXT	PAGE/PATH	DESTINATION DESIGNATION FROM	CONNECTION	CORE	DESTINATION DESIGNATION TO	CONNECTION	PAGE/PATH	FUNCTION TEXT	
CONVEYOR BELT 6	=100/12.2	-X1	PE	GNYE	+M-6X1	PE	=100/12.2	CONVEYOR BELT 6	
CONVEYOR BELT 6	=100/12.1	-X1	15	BN	+M-6X1	2	=100/12.1	CONVEYOR BELT 6	
CONVEYOR BELT 6	=100/12.1	-X1	14	BK	+M-6X1	1	=100/12.1	CONVEYOR BELT 6	
CONVEYOR BELT 6	=100/12.1	-X1	16	GY	+M-6X1	3	=100/12.1	CONVEYOR BELT 6	







# INTERCONNECTION DIAGRAM

TPS\_N\_20.SKN / 2005-07-25

CABLE NAME -12W4				CABLE TYPE H07RN-F					
REMARK				NO. OF CORES 4		CROSS SECTION 6		CABLE LENGTH -	
FUNCTION TEXT	PAGE/PATH	DESTINATION DESIGNATION FROM	CONNECTION	CORE	DESTINATION DESIGNATION TO	CONNECTION	PAGE/PATH	FUNCTION TEXT	
VIBRATING SCREEN 7	=100/12.4	-X1	PE	GNYE	=100+M-7M1	PE	=100/12.4	VIBRATING SCREEN 7	
VIBRATING SCREEN 7	=100/12.4	-X1	18	BN	=100+M-7M1	V1	=100/12.4	VIBRATING SCREEN 7	
VIBRATING SCREEN 7	=100/12.4	-X1	17	BK	=100+M-7M1	U1	=100/12.4	VIBRATING SCREEN 7	
VIBRATING SCREEN 7	=100/12.4	-X1	19	GY	=100+M-7M1	W1	=100/12.4	VIBRATING SCREEN 7	

33

35

**INTERCONNECTION DIAGRAM**

TPS\_N\_20.SKN / 2005-07-25

CABLE NAME <b>-13W1</b>					CABLE TYPE <b>H07RN-F</b>					
REMARK					NO. OF CORES <b>4</b>		CROSS SECTION <b>1.5</b>		CABLE LENGTH <b>-</b>	
FUNCTION TEXT	PAGE/PATH	DESTINATION DESIGNATION FROM	CONNECTION	CORE	DESTINATION DESIGNATION TO	CONNECTION	PAGE/PATH	FUNCTION TEXT		
HYDRAULIC 9	=100/13.2	-X1	PE	GNYE	=100+M-9M1	PE	=100/13.1	HYDRAULIC 9		
HYDRAULIC 9	=100/13.1	-X1	21	BN	=100+M-9M1	V	=100/13.1	HYDRAULIC 9		
HYDRAULIC 9	=100/13.1	-X1	20	BK	=100+M-9M1	U	=100/13.1	HYDRAULIC 9		
HYDRAULIC 9	=100/13.1	-X1	22	GY	=100+M-9M1	W	=100/13.1	HYDRAULIC 9		

34	DATE	06.Mai.2013	KLEEMANN GMBH			-13W1	KLEEMANN SERIES	K007	= KAB	+
	EDITED	PC1	MOBICAT MC 120 Z EU				KLEEMANN MATERIAL NO	2315434	CAE-SYSTEM: EPLAN 5.70	PG.
MODIFICAT.	DATE	NAME	NORM	DIN	ORIGIN	REP.F.	REP.T.		PG.	48

**INTERCONNECTION DIAGRAM**

TPS\_N\_20.SKN / 2005-07-25

CABLE NAME <b>-13W2</b>					CABLE TYPE <b>H07RN-F</b>					
REMARK					NO. OF CORES <b>3</b>		CROSS SECTION <b>1.5</b>		CABLE LENGTH <b>-</b>	
FUNCTION TEXT	PAGE/PATH	DESTINATION DESIGNATION FROM	CONNECTION	CORE	DESTINATION DESIGNATION TO	CONNECTION	PAGE/PATH	FUNCTION TEXT		
WATERPUMP 10	=100/13.5	-X1	PE	GNYE	=100+M-WP	PE	=100/13.4	HYDRAULIC 9		
WATERPUMP 10	=100/13.5	-X1	24	BU	=100+M-WP	N	=100/13.4	HYDRAULIC 9		
WATERPUMP 10	=100/13.4	-X1	23	BN	=100+M-WP	L1	=100/13.4	HYDRAULIC 9		

**INTERCONNECTION DIAGRAM**

TPS\_N\_20.SKN / 2005-07-25

CABLE NAME <b>-13W3</b>					CABLE TYPE <b>H07RN-F</b>					
REMARK					NO. OF CORES <b>4</b>		CROSS SECTION <b>1.5</b>		CABLE LENGTH <b>-</b>	
FUNCTION TEXT	PAGE/PATH	DESTINATION DESIGNATION FROM	CONNECTION	CORE	DESTINATION DESIGNATION TO	CONNECTION	PAGE/PATH	FUNCTION TEXT		
OVERPRESSURE FAN	=100/13.7	-X1	PE	GNYE	=100+M-13M1	PE	=100/13.7	OVERPRESSURE FAN		
OVERPRESSURE FAN	=100/13.7	-X1	26	BN	=100+M-13M1	V	=100/13.7	OVERPRESSURE FAN		
OVERPRESSURE FAN	=100/13.7	-X1	25	BK	=100+M-13M1	U	=100/13.7	OVERPRESSURE FAN		
OVERPRESSURE FAN	=100/13.7	-X1	27	GY	=100+M-13M1	W	=100/13.7	OVERPRESSURE FAN		

**INTERCONNECTION DIAGRAM**

TPS\_N\_20.SKN / 2005-07-25

CABLE NAME				<b>-14W1</b>				CABLE TYPE				<b>OELFLEX FD855CP</b>															
REMARK				NO. OF CORES				<b>4G+Schirm</b>				CROSS SECTION				<b>2.5</b>				CABLE LENGTH				<b>-</b>			
FUNCTION TEXT		PAGE/PATH		DESTINATION DESIGNATION FROM		CONNECTION	CORE	DESTINATION DESIGNATION TO		CONNECTION	PAGE/PATH		FUNCTION TEXT														
VIBRATING FEEDER 8 DRIVE LEFT		=100/14.2		-X8		1	1	=100+M-8M1		U1	=100/14.2		VIBRATING FEEDER 8 DRIVE LEFT														
VIBRATING FEEDER 8 DRIVE LEFT		=100/14.2		-X8		2	2	=100+M-8M1		V1	=100/14.2		VIBRATING FEEDER 8 DRIVE LEFT														
VIBRATING FEEDER 8 DRIVE LEFT		=100/14.3		-X8		3	3	=100+M-8M1		W1	=100/14.2		VIBRATING FEEDER 8 DRIVE LEFT														
VIBRATING FEEDER 8 DRIVE LEFT		=100/14.3		-X8		PE	PE	=100+M-8M1		PE	=100/14.2		VIBRATING FEEDER 8 DRIVE LEFT														
							SH																				

		DATE		06.Mai.2013		KLEEMANN GMBH				-14W1		KLEEMANN SERIES		K007		= KAB		+	
		EDITED		PC1		MOBICAT MC 120 Z EU						KLEEMANN MATERIAL NO		2315434		CAE-SYSTEM: EPLAN 5.70		PG. 38	
MODIFICAT.		DATE		NAME		NORM		DIN		ORIGIN		REP.F.		REP.T.				PG. 48	

**INTERCONNECTION DIAGRAM**

TPS\_N\_20.SKN / 2005-07-25

CABLE NAME	<b>-14W2</b>	CABLE TYPE	<b>OELFLEX FD855CP</b>
------------	--------------	------------	------------------------

REMARK	NO. OF CORES	<b>4G+Schirm</b>	CROSS SECTION	<b>2.5</b>	CABLE LENGTH	<b>-</b>
--------	--------------	------------------	---------------	------------	--------------	----------

FUNCTION TEXT	PAGE/PATH	DESTINATION DESIGNATION FROM	CONNECTION	CORE	DESTINATION DESIGNATION TO	CONNECTION	PAGE/PATH	FUNCTION TEXT
VIBRATING FEEDER 8 DRIVE RIGHT	=100/14.4	-X8	4	1	=100+M-8M2	U1	=100/14.4	VIBRATING FEEDER 8 DRIVE RIGHT
VIBRATING FEEDER 8 DRIVE RIGHT	=100/14.4	-X8	5	2	=100+M-8M2	V1	=100/14.4	VIBRATING FEEDER 8 DRIVE RIGHT
VIBRATING FEEDER 8 DRIVE RIGHT	=100/14.4	-X8	6	3	=100+M-8M2	W1	=100/14.4	VIBRATING FEEDER 8 DRIVE RIGHT
VIBRATING FEEDER 8 DRIVE RIGHT	=100/14.5	-X8	PE	PE	=100+M-8M2	PE	=100/14.4	VIBRATING FEEDER 8 DRIVE RIGHT
				SH				

DATE	06.Mai.2013	KLEEMANN GMBH	 	-14W2	KLEEMANN SERIES	K007	= KAB	+	
EDITED	PC1	MOBICAT MC 120 Z EU		KLEEMANN MATERIAL NO	2315434	CAE-SYSTEM:	EPLAN 5.70	PG.	39
CONTR.	D. MALLKOWSKY							PG.	48
MODIFICAT.	DATE	NAME	NORM	DIN	ORIGIN	REP.F.	REP.T.		



**INTERCONNECTION DIAGRAM**

TPS\_N\_20.SKN / 2005-07-25

CABLE NAME <b>-36W2</b>				CABLE TYPE <b>UNITRONIC</b>			
-------------------------	--	--	--	-----------------------------	--	--	--

REMARK				NO. OF CORES <b>3+Schirm</b>		CROSS SECTION <b>0.5</b>		CABLE LENGTH <b>-</b>	
--------	--	--	--	------------------------------	--	--------------------------	--	-----------------------	--

FUNCTION TEXT	PAGE/PATH	DESTINATION DESIGNATION FROM	CONNECTION	CORE	DESTINATION DESIGNATION TO	CONNECTION	PAGE/PATH	FUNCTION TEXT
				WH				
LIGHT BARRIER CRUSHER	=100/36.4	-XLS	2	BN	=100+M-LT	5	=100/36.4	LIGHT BARRIER CRUSHER
LIGHT BARRIER CRUSHER	=100/36.4	-XLS	1	GN	=100+M-LT	7	=100/36.4	LIGHT BARRIER CRUSHER
				SH				



# INTERCONNECTION DIAGRAM

TPS\_N\_20.SKN / 2005-07-25

CABLE NAME					CABLE TYPE					
-37W1					H07RN-F.					
REMARK					NO. OF CORES		CROSS SECTION		CABLE LENGTH	
					4		4		-	
FUNCTION TEXT	PAGE/PATH	DESTINATION DESIGNATION FROM	CONNECTION	CORE	DESTINATION DESIGNATION TO	CONNECTION	PAGE/PATH	FUNCTION TEXT		
				GNYE						
				BN						
SUPPLY 24V	=100/37.0	-XG	30	BK	+M-XG	30	=100/37.0	SUPPLY 24V		
SUPPLY 0V	=100/37.1	-XG	31	GY	+M-XG	31	=100/37.1	SUPPLY 0V		

DATE		06.Mai.2013		KLEEMANN GMBH			 	KLEEMANN SERIES		K007		= KAB		+	
EDITED		PC1		MOBICAT MC 120 Z EU				KLEEMANN MATERIAL NO		2315434		CAE-SYSTEM: EPLAN 5.70		PG. 42	
CONTR.		D. MALLKOWSKY												PG. 48	
MODIFICAT.	DATE	NAME	NORM	DIN	ORIGIN	REP.F.	REP.T.								

**INTERCONNECTION DIAGRAM**

TPS\_N\_20.SKN / 2005-07-25

CABLE NAME				CABLE TYPE					
-37W2				OELFLEX 110					
REMARK				NO. OF CORES		CROSS SECTION		CABLE LENGTH	
				18G		1		-	
FUNCTION TEXT	PAGE/PATH	DESTINATION DESIGNATION FROM	CONNECTION	CORE	DESTINATION DESIGNATION TO	CONNECTION	PAGE/PATH	FUNCTION TEXT	
DYNAMO	=100/37.3	-XG	61	1	+M-XG	61	=100/37.3	DYNAMO	
START	=100/37.4	-XG	50	2	+M-XG	50	=100/37.4	START	
RELEASE	=100/37.6	-XG	3	3	+M-XG	3	=100/37.6	RELEASE	
	=100/38.2	-XG	5	4	+M-XG	5	=100/38.2		
PREWARNING OVERTEMPERATURE	=100/38.2	-XG	7	5	+M-XG	7	=100/38.2	PREWARNING OVERTEMPERATURE	
COOLING WATER LOW LEWEL	=100/38.3	-XG	8	6	+M-XG	8	=100/38.3	COOLING WATER LOW LEWEL	
COOLING WATER LOW LEWEL	=100/38.4	-XG	7.1	7	+M-XG	7.1	=100/38.4	COOLING WATER LOW LEWEL	
COOLING WATER LOW LEWEL	=100/38.5	-XG	5.1	8	+M-XG	5.1	=100/38.5	COOLING WATER LOW LEWEL	
AIR FILTER PLUGGES	=100/40.6	-XG	11	9	+M-XG	11	=100/40.6	AIR FILTER PLUGGES	
FUEL LEVEL	=100/40.7	-XG	18	10	+M-XG	18	=100/40.7	FUEL LEVEL	
				11					
				12					
				13					
				14					
				15					
				16					
				17					
				PE					

DATE		06.Mai.2013		KLEEMANN GMBH		 	-37W2		KLEEMANN SERIES		K007		= KAB		+	
EDITED		PC1		MOBICAT MC 120 Z EU					KLEEMANN MATERIAL NO		2315434		CAE-SYSTEM: EPLAN 5.70		PG. 43	
MODIFICAT.	DATE	NAME	NORM	DIN	ORIGIN	REP.F.	REP.T.							PG. 48		

**INTERCONNECTION DIAGRAM**

TPS\_N\_20.SKN / 2005-07-25

CABLE NAME				CABLE TYPE					
-41W1				H07RN-F					
REMARK				NO. OF CORES		CROSS SECTION		CABLE LENGTH	
				19G		1.5		-	
FUNCTION TEXT	PAGE/PATH	DESTINATION DESIGNATION FROM	CONNECTION	CORE	DESTINATION DESIGNATION TO	CONNECTION	PAGE/PATH	FUNCTION TEXT	
	=100/41.1	-XF	1	1			=100/41.1		
VIBRATING CHUTE SLOWER (RADIO)	=100/41.5	-XF	2	2			=100/41.1		
INSTALLATION OFF (RADIO)	=100/41.2	-XF	3	3			=100/41.1		
INSTALLATION OFF (RADIO)	=100/41.2	-XF	4	4			=100/41.1		
				5					
				6					
				7					
VIBRATING CHUTE FASTER (RADIO)	=100/41.4	-XF	8	8			=100/41.1		
VIBRATING CHUTE + SCREEN OFF(REMOTE)	=100/41.3	-XF	9	9			=100/41.1		
VIBRATING CHUTE SLOWER (RADIO)	=100/41.4	-XF	10	10			=100/41.1		
VIBRATING CHUTE + SCREEN ON(REMOTE)	=100/41.2	-XF	11	11			=100/41.1		
				12					
RUN CHAIN RIGHT (REMOTE)	=100/41.6	-XF	C1	13	=100+M-20A2	13	=100/41.1		
RUN CHAIN RIGHT (REMOTE)	=100/41.7	-XF	D1	14	=100+M-20A2	14	=100/41.1		
RUN CHAIN LEFT (REMOTE)	=100/41.6	-XF	C2	15	=100+M-20A2	15	=100/41.1		
RUN CHAIN LEFT (REMOTE)	=100/41.5	-XF	D2	16	=100+M-20A2	16	=100/41.1		
	=100/41.1	-XF		6			=100/41.1		
	=100/41.1	-XF		7			=100/41.1		
				PE					

DATE		06.Mai.2013		KLEEMANN GMBH		 		KLEEMANN SERIES		K007		= KAB		+	
EDITED		PC1		MOBICAT MC 120 Z EU				KLEEMANN MATERIAL NO		2315434		CAE-SYSTEM: EPLAN 5.70		PG. 44	
CONTR.		D. MALLKOWSKY		ORIGIN		REP.F.		REP.T.				PG. 48			

# INTERCONNECTION DIAGRAM

CABLE NAME **-41W2**      CABLE TYPE **OELFLEX 540P**

REMARK      NO. OF CORES **5G**      CROSS SECTION **0.75**      CABLE LENGTH **-**

FUNCTION TEXT	PAGE/PATH	DESTINATION DESIGNATION FROM	CONNECTION	CORE	DESTINATION DESIGNATION TO	CONNECTION	PAGE/PATH	FUNCTION TEXT
RUN CHAIN LEFT (MANUAL)	=100/41.8	-X22	A2	1	=100+M-Y5B	A2	=100/41.7	RUN CHAIN RIGHT (REMOTE)
RUN CHAIN LEFT (MANUAL)	=100/41.8	-X22	B2	2	=100+M-Y5B	B2	=100/41.7	RUN CHAIN RIGHT (REMOTE)
RUN CHAIN LEFT (REMOTE)	=100/41.6	-XF	C2	3	=100+M-Y5B	C2	=100/41.7	RUN CHAIN RIGHT (REMOTE)
RUN CHAIN LEFT (REMOTE)	=100/41.5	-XF	D2	4	=100+M-Y5B	D2	=100/41.7	RUN CHAIN RIGHT (REMOTE)
				PE				

# INTERCONNECTION DIAGRAM

TPS\_N\_20.SKN / 2005-07-25

CABLE NAME				CABLE TYPE					
-41W3				OELFLEX 540P					
REMARK				NO. OF CORES		CROSS SECTION		CABLE LENGTH	
				5G		0.75		-	
FUNCTION TEXT	PAGE/PATH	DESTINATION DESIGNATION FROM	CONNECTION	CORE	DESTINATION DESIGNATION TO	CONNECTION	PAGE/PATH	FUNCTION TEXT	
RUN CHAIN RIGHT (MANUAL)	=100/41.7	-X22	A1	1	=100+M-Y4B	A1	=100/41.6	RUN CHAIN RIGHT (REMOTE)	
RUN CHAIN RIGHT (MANUAL)	=100/41.7	-X22	B1	2	=100+M-Y4B	B1	=100/41.6	RUN CHAIN RIGHT (REMOTE)	
RUN CHAIN RIGHT (REMOTE)	=100/41.7	-XF	D1	3	=100+M-Y4B	D1	=100/41.6	RUN CHAIN RIGHT (REMOTE)	
RUN CHAIN RIGHT (REMOTE)	=100/41.6	-XF	C1	4	=100+M-Y4B	C1	=100/41.6	RUN CHAIN RIGHT (REMOTE)	
				PE					

# INTERCONNECTION DIAGRAM

TPS\_N\_20.SKN / 2005-07-25

CABLE NAME <b>-41W4</b>					CABLE TYPE <b>OELFLEX 110</b>					
REMARK					NO. OF CORES <b>7G</b>		CROSS SECTION <b>1.5</b>		CABLE LENGTH <b>-</b>	
FUNCTION TEXT	PAGE/PATH	DESTINATION DESIGNATION FROM	CONNECTION	CORE	DESTINATION DESIGNATION TO	CONNECTION	PAGE/PATH	FUNCTION TEXT		
EINSPEISUNG 24V DC	=100/41.7	-X22	1	1	+M-XF1	1	=100/41.7	EINSPEISUNG 24V DC		
EINSPEISUNG 0V DC	=100/41.9	-X22	2	2	+M-XF1	2	=100/41.9	EINSPEISUNG 0V DC		
RUN CHAIN LEFT (MANUAL)	=100/41.8	-X22	B2	3	+M-XF1	3	=100/41.8	RUN CHAIN LEFT (MANUAL)		
RUN CHAIN LEFT (MANUAL)	=100/41.8	-X22	A2	4	+M-XF1	4	=100/41.8	RUN CHAIN LEFT (MANUAL)		
RUN CHAIN RIGHT (MANUAL)	=100/41.7	-X22	B1	5	+M-XF1	5	=100/41.7	RUN CHAIN RIGHT (MANUAL)		
RUN CHAIN RIGHT (MANUAL)	=100/41.7	-X22	A1	6	+M-XF1	6	=100/41.7	RUN CHAIN RIGHT (MANUAL)		
				PE						

DATE	06.Mai.2013	KLEEMANN GMBH			-41W4	KLEEMANN SERIES	K007	= K A B	+
EDITED	PC1	MOBICAT MC 120 Z EU				KLEEMANN MATERIAL NO	2315434	CAE-SYSTEM:	PG. 47
CONTR.	D. MALLKOWSKY						EPLAN 5.70	PG.	48
MODIFICAT.	DATE	NAME	NORM	DIN	ORIGIN	REP.F.	REP.T.		



# Part's list

TPLSTK05 12.10.2015

Component designation	Amount	DESIGNATION	Manufacturer	Article number	Page/Path	Model number
-XOUT	1	Anbauegahäuse 16-pol. mit 2 Buegeln	ILME GmbH	M10020941	=A0/19.6	CHI 16
-XOUT	1	Tuellengehäuse M25 mit Bolzen für 2 Bügel	ILME GmbH	M10011806	=A0/19.6	MHO 16.25
-XOUT	1	Buchseneinsatz 16-polig +PE 16A max, 400V	ILME GmbH	M10011811	=A0/19.6	CNF 16
-XOUT	1	Stifteinsatz 16-polig +PE 16A max, 500V	ILME GmbH	M10011812	=A0/19.6	CSEM 16
-3X2	1	Tuellengehäuse 4-pol. +PE mit Buegel und Verschraubung, Metall	ILME GmbH	M10011803	=A0/19.6	CKA 03 VGS
-3X2	1	Stifteinsatz 4-polig +PE 10A max, 250V	ILME GmbH	M10011804	=A0/19.6	CKM 04
-3X2	1	Buchseneinsatz 4-polig +PE 10A max, 250V	ILME GmbH	M10011805	=A0/19.6	CKF 04
-4X1	1	Stifteinsatz 4+2-polig +PE 80A max+16A max, 400V	ILME GmbH	M10012918	=A0/19.6	CXM 4/2
-4X1	1	Buchseneinsatz 4+2-polig +PE 80A max+16A max, 400V	ILME GmbH	M10012917	=A0/19.6	CXF 4/2
-4X1	1	Anbauegahäuse 16-pol. mit 2 Buegeln	ILME GmbH	M10020941	=A0/19.6	CHI 16
-4X1	1	Tuellengehäuse M32 mit Bolzen für 2 Bügel	ILME GmbH	MHO 16.32	=A0/19.6	MHO 16.32
-4X2	1	Stifteinsatz 4-polig +PE 10A max, 250V	ILME GmbH	M10011804	=A0/19.6	CKM 04
-4X2	1	Buchseneinsatz 4-polig +PE 10A max, 250V	ILME GmbH	M10011805	=A0/19.6	CKF 04
-4X2	1	Anbauegahäuse ohne Kabelausgang	ILME GmbH	CKAX 03 IA	=A0/19.6	2454383
-4X2	1	Tuellengehäuse mit Bolzen	ILME GmbH	MKA V20	=A0/19.6	M10011803
=100-0P1	1	Amperemeter 800/1600/5A	Langer Messtechnik GmbH	M10009940	=100/1.0	RQ 72 E 800/1600/5A
=100-0T02	1	Summenstromwandler 500mA fuer FI-Relais Typ MFR	Doepke	MFIW 105/0,5	=100/1.1	MFIW 105/0,5
=100-0Q1	1	Leistungsschalter 3p 630A BG3	Moeller	M10017488	=100/1.1	NZMN3-AE630
=100-0Q1	1	Unterspannungsauslöser mit 2 VHI	Moeller	M10017491	=100/1.1	NZM2/3-XUHV380-440AC
=100-0Q1	1	Hauptschalterbausatz f. NZM3(-4), PN3(-4), N3(-4)	Moeller	M10017494	=100/1.1	NZM3-XHBR
=100-0Q1	1	Kontaktelement 1S Front M22-CK10	Moeller	M10016214	=100/1.1	M22-CK10
=100-0T01	1	Stromwandler AC 40 800/5A	Langer Messtechnik GmbH	M00000010	=100/1.1	TAC 40 800/5A
=100-0F00	1	NEOZED Sicherungssockel, 3-polig, D01, 16A, E14, mit Isolierstoffdeckel	Lindner	2734.	=100/1.2	2734.
=100-0F00	2	NEOZED Schraubkappe Kunststoff D01, 16A, E14, mit Pruefloch	Siemens	5SH4116	=100/1.2	5SH4116
=100-0F00	2	NEOZED-Sicherungseinsatz D01, 2A 400VAC/250VDC, gL-gG	Lindner	M10006604	=100/1.2	1700.002
=100-0F00	2	NEOZED Huelseinsatz 2A Sockel D01	Lindner	M10021286	=100/1.2	1705.002
=100-PE	2	Sammelschienehalter 1polig	Rittal GmbH & Co. KG	SV 9340.030	=100/1.2	SV 9340.030
=100-0F01	1	FI-Steuerschalter 2S, 500V, 16A	Doepke	M10016345	=100/1.3	MFR
=100-0F09	1	NEOZED Schraubkappe Kunststoff D01, 16A, E14, mit Pruefloch	Siemens	5SH4116	=100/1.4	5SH4116
=100-0F09	1	NEOZED Huelseinsatz 2A Sockel D01	Lindner	M10021286	=100/1.4	1705.002
=100-0F09	1	NEOZED-Sicherungseinsatz D01, 2A 400VAC/250VDC, gL-gG	Lindner	M10006604	=100/1.4	1700.002
=100-P5	1	Betriebsstundenzaehler 230V AC	ABB AG	M10011840	=100/1.4	E233-230
=100-0F06	1	NEOZED Sicherungssockel, 1-polig, D01, 16A, E14, mit Isolierstoffdeckel	Lindner	2724.	=100/3.1	2724.
=100-0F06	1	NEOZED Schraubkappe Kunststoff D01, 16A, E14, mit Pruefloch	Siemens	5SH4116	=100/3.1	5SH4116
=100-0F06	1	NEOZED-Sicherungseinsatz D01, 6A 400VAC/250VDC, gL-gG	Lindner	M10004051	=100/3.1	1700.006
=100-0F06	1	NEOZED Huelseinsatz 6A Sockel D01	Lindner	M10021288	=100/3.1	1705.006
=100-0F07	1	NEOZED Sicherungssockel, 1-polig, D01, 16A, E14, mit Isolierstoffdeckel	Lindner	2724.	=100/3.3	2724.
=100-0F07	1	NEOZED Schraubkappe Kunststoff D01, 16A, E14, mit Pruefloch	Siemens	5SH4116	=100/3.3	5SH4116
=100-0F07	1	NEOZED-Sicherungseinsatz D01, 6A 400VAC/250VDC, gL-gG	Lindner	M10004051	=100/3.3	1700.006
=100-0F07	1	NEOZED Huelseinsatz 6A Sockel D01	Lindner	M10021288	=100/3.3	1705.006
=100-0F08	1	NEOZED Sicherungssockel, 1-polig, D01, 16A, E14, mit Isolierstoffdeckel	Lindner	2724.	=100/3.5	2724.
=100-0F08	1	NEOZED Schraubkappe Kunststoff D01, 16A, E14, mit Pruefloch	Siemens	5SH4116	=100/3.5	5SH4116
=100-0F08	1	NEOZED-Sicherungseinsatz D01, 6A 400VAC/250VDC, gL-gG	Lindner	M10004051	=100/3.5	1700.006
=100-0F08	1	NEOZED Huelseinsatz 6A Sockel D01	Lindner	M10021288	=100/3.5	1705.006
=100-SX	1	Knebel 2 Schalterstellungen, verrastend, schwarz, 1S	Siemens	M10021302	=100/3.7	3SB32 02-2KA11-0CC0
=100-SX	1	Schutzkappe für Knebel	Siemens	3SB39 21-0BA	=100/3.7	3SB39 21-0BA
=100-SX	1	Schildtraeger	Siemens	3SB39 25-0AV	=100/3.7	3SB39 25-0AV
=100-KX	1	Steckschalter mit Relais 2 Wechsler 250V AC/8A Spule 24V DC	Wago GmbH & Co. KG	M10019133 + M10019138	=100/3.7	788-312
=100-0F03	1	NEOZED Sicherungssockel, 3-polig, D02, 63A, E18, mit Isolierstoffdeckel	Lindner	2735.	=100/4.1	2735.
=100-0F03	3	NEOZED Schraubkappe Kunststoff D02, 63A, E18, mit Pruefloch	Siemens	5SH4163	=100/4.1	5SH4163

=KAB/48

2

DATE		04.Dez.2015		KLEEMANN GMBH		 	STUECKLISTE		KLEEMANN SERIES K007		= STK		+	
EDITED		JBR		MOBICAT MC 120 Z EU					KLEEMANN MATERIAL NO 2315434		CAE-SYSTEM: EPLAN 5.70		PG. 1	
MODIFICAT.	DATE	NAME	NORM	DIN	ORIGIN	REP.F.	REP.T.					PG. 13		



# Part's list

TPLSTK05 12.10.2015

Component designation	Amount	DESIGNATION	Manufacturer	Article number	Page/Path	Model number
=100-0F03	3	NEOZED Sicherungseinsatz 35A	D02, 400VAC/250VDC, gL-gG	Lindner	M10006607	=100/4.1 1701.035
=100-0F03	3	NEOZED Huelseinsatz 35A	Socket D02	Lindner	M10021297	=100/4.1 1706.035
=100-0F04	1	FI-Schutzschalter	400V 40A/30mA	Legrand	M10025396	=100/4.1 DX 40A 40/0,03
=100-0X4	1	Anbausteckdose	5-pol 32A, 400V	Hilpress GmbH	56024	=100/4.1 56024
=100-0F05	1	NEOZED Sicherungssockel, 1-polig,	D01, 16A, E14, mit Isolierstoffdeckel	Lindner	2724.	=100/4.3 2724.
=100-0F05	1	NEOZED Schraubkappe Kunststoff	D01, 16A, E14, mit Pruefloch	Siemens	5SH4116	=100/4.3 5SH4116
=100-0F05	1	NEOZED-Sicherungseinsatz D01, 16A	400VAC/250VDC, gL-gG	Lindner	M10006605	=100/4.3 1700.016
=100-0X5	1	Anbausteckdose	2-pol 16A, 250V	Hilpress GmbH	M10009114	=100/4.3 56090
=100-0F0	1	NH-Sicherungslasttrenner Gr.00	160A, 690V	Rittal GmbH & Co. KG	SV 9343.010	=100/5.1 SV 9343.010
=100-0F0	3	NH-Sicherungseinsatz Gr.000 100A	500V AC/250V DC/gL/gG	Siemens	3NA7 830	=100/5.1 3NA7 830
=100-0X1	1	Steckdose AD385X5S	5-pol 125A, 400V	ELSPRO GmbH	M10011844	=100/5.1 AD385X5S
=100-0F1	1	SV Reitersicherungselement	Typ D 02-E 18	Rittal GmbH & Co. KG	M10011818	=100/5.4 SV 3418.000
=100-0F1	1	Seitliche Abdeckung		Rittal GmbH & Co. KG	M00000008	=100/5.4 SV 3093.000
=100-0F1	2	NEOZED Huelseinsatz 10A	Socket D02	Lindner	M10021293	=100/5.4 1706.01
=100-0F1	2	NEOZED-Sicherungseinsatz D01, 10A	400VAC/250VDC, gL-gG	Lindner	M10004052	=100/5.4 1700.01
=100-0F1	2	NEOZED Schraubkappe Kunststoff	D02, 63A, E18, mit Pruefloch	Siemens	5SH4163	=100/5.4 5SH4163
=100-0F1	2	NEOZED Haltefeder 2 - 16 A	D02	Lindner	1713.	=100/5.4 1713.
=100-0T1	1	Transformator 1-phasig 500VA	prim. 400V/1,36A sek. 230V/2,2A	Block GmbH & Co.KG	M00000014	=100/5.4 ST 500/4/23
=100-0F1.3	1	Sicherungsautomat 1-polig Typ C	2A 400V AC/220V DC	Siemens	M10019972	=100/5.4 5SY6 102-7
=100-0F1.3	1	Hilfsschalter 1S 10E	fuer LS-Schalter T=70mm	Siemens	M10019130	=100/5.4 5ST3 010
=100-0F02	1	SV Reitersicherungselement	Typ D 02-E 18	Rittal GmbH & Co. KG	M10011818	=100/5.7 SV 3418.000
=100-0F02	1	Beruehrungsschutzabdeckung	Typ D 02-E 18	Rittal GmbH & Co. KG	SV 3419.000	=100/5.7 SV 3419.000
=100-0F02	1	Seitliche Abdeckung		Rittal GmbH & Co. KG	M00000008	=100/5.7 SV 3093.000
=100-0F02	2	NEOZED-Sicherungseinsatz D01, 2A	400VAC/250VDC, gL-gG	Lindner	M10006604	=100/5.7 1700.002
=100-0F02	2	NEOZED Huelseinsatz 2A	Socket D02	Lindner	M10021290	=100/5.7 1706.002
=100-0F02	2	NEOZED Schraubkappe Kunststoff	D02, 63A, E18, mit Pruefloch	Siemens	5SH4163	=100/5.7 5SH4163
=100-0F02	2	NEOZED Haltefeder 2 - 16 A	D02	Lindner	1713.	=100/5.7 1713.
=100-0P2	1	Voltmeter 500V		Langer Messtechnik GmbH	M10006617	=100/5.7 RQ 72 E 500V
=100-0S00	1	Pilzdrucktaster rot,	1S+1OE , rastend , mit Drehentriegelung	Siemens	M10015479	=100/6.6 3SB32 01-1HA20-0CC0
=100-0S00	2	Schaltelement mit 1 Schaltglied 1S		Siemens	M10017540	=100/6.6 3SB34 03-0B
=100-0S00	1	Schutzkappe	für Pilz-Drucktaster	Siemens	3SB19 02-2BH	=100/6.6 3SB19 02-2BH
=100-0S00	1	Schildtraeger	für NOT-AUS Pilz-Drucktaster	Moeller	M22-XAK1	=100/6.6 M22-XAK1
=100+S-XSBT1	1	Buchseneinsatz 10-polig +PE	16A max, 500V	ILME GmbH	2302895	=100/6.7 CSEF 10
=100+S-XSBT1	1	Anbauehaeuse	mit 2 Buegel	ILME GmbH	2332565	=100/6.7 CHI 10
=100+S-XSBT2	1	Tuellengehaeuse M20 rot		ILME GmbH	2332604	=100/6.7 MHOR 10.20
=100+S-XSBT2	1	Stifteinsatz 10-polig +PE	16A max, 500V	ILME GmbH	2302911	=100/6.7 CSEM 10
=100+S-XSBT2.	1	Tuellengehaeuse M20	mit Bolzen für 2 Bügel	ILME GmbH	2302913	=100/6.7 MHO 10.20
=100+S-XSBT2.	1	Stifteinsatz 10-polig +PE	16A max, 500V	ILME GmbH	2302911	=100/6.7 CSEM 10
=100-D1	1	Schaltgeraet, 24V	3S+1OE	Pilz GmbH & Co.	M10015065	=100/6.1.4 PNOZ X4
=100-0F2	1	NEOZED Sicherungssockel, 1-polig,	D01, 16A, E14, mit Isolierstoffdeckel	Lindner	2724.	=100/7.1 2724.
=100-0F2	1	NEOZED Schraubkappe Kunststoff	D01, 16A, E14, mit Pruefloch	Siemens	5SH4116	=100/7.1 5SH4116
=100-0F2	1	NEOZED-Sicherungseinsatz D01, 6A	400VAC/250VDC, gL-gG	Lindner	M10004051	=100/7.1 1700.006
=100-0F2	1	NEOZED Huelseinsatz 6A	Socket D01	Lindner	M10021288	=100/7.1 1705.006
=100-KN1	1	Hilfsschuetz SIRIUS	2S+2OE 24VDC, Cage Clamp	Siemens	2256202	=100/7.1 3RH2122-2BB40
=100-KN2	1	Hilfsschuetz SIRIUS	2S+2OE 24VDC, Cage Clamp	Siemens	2256202	=100/7.2 3RH2122-2BB40
=100-0F3	1	Sicherungseinsatz Gr.10 x 38	16A, 660V, gR	Woechner GmbH & Co. KG	M10019069	=100/7.3 31 211
=100-0F3	1	Hilfsschalter 1S 10E	fuer LS-Schalter T=70mm	Siemens	M10019130	=100/7.3 5ST3 010
=100-0S1	1	Schlusselschalter, O-1 Ronis	1S mit Halter	Siemens	M10021350	=100/7.3 3SB32 02-4AD11-0CC0
=100-0S1	1	Schildtraeger		Siemens	3SB39 25-0AV	=100/7.3 3SB39 25-0AV
=100-0K1	1	Schuetz, 4kW/400V	3H 1S 24V DC, Cage-Clamp	Siemens	2256186	=100/7.3 3RT2016-2BB41

DATE	04.Dez.2015	KLEEMANN GMBH	 	STUECKLISTE	KLEEMANN SERIES	K007	= STK	+
EDITED	JBR	MOBICAT MC 120 Z EU			KLEEMANN MATERIAL NO	2315434	CAE-SYSTEM: EPLAN 5.70	PG.
CONTR.	D. MALLKOWSKY						PG.	13
MODIFICAT.	DATE	NAME	NORM	DIN	ORIGIN	REP.F.	REP.T.	

# Part's list

TPLSTK05 12.10.2015

Component designation	Amount	DESIGNATION	Manufacturer	Article number	Page/Path	Model number
=100-0K1	1	Hilfsschalterblock 2S+2OE Cage-Clamp-Anschluss	Siemens	2255490	=100/7.3	3RH2911-2FA22
=100-GF2	1	NEOZED Sicherungssockel, 1-polig, D01, 16A, E14, mit Isolierstoffdeckel	Lindner	2724.	=100/7.5	2724.
=100-GF2	1	NEOZED Schraubkappe Kunststoff D01, 16A, E14, mit Pruefloch	Siemens	5SH4116	=100/7.5	5SH4116
=100-GF2	1	NEOZED-Sicherungseinsatz D01, 10A 400VAC/250VDC, gL-gG	Lindner	M10004052	=100/7.5	1700.01
=100-GF2	1	NEOZED Huelseneinsatz 10A Sockel D01	Lindner	M10021289	=100/7.5	1705.01
=100-0F4	1	NEOZED Sicherungssockel, 1-polig, D01, 16A, E14, mit Isolierstoffdeckel	Lindner	2724.	=100/7.6	2724.
=100-0F4	1	NEOZED Schraubkappe Kunststoff D01, 16A, E14, mit Pruefloch	Siemens	5SH4116	=100/7.6	5SH4116
=100-0F4	1	NEOZED-Sicherungseinsatz D01, 2A 400VAC/250VDC, gL-gG	Lindner	M10006604	=100/7.6	1700.002
=100-0F4	1	NEOZED Huelseneinsatz 2A Sockel D01	Lindner	M10021286	=100/7.6	1705.002
=100-0F4	1	NEOZED Haltefeder 2 - 16 A D02	Lindner	1713.	=100/7.6	1713.
=100+M-00H2	1	Sirene 24V DC, 0,5A	Funke+Huster GmbH	M10011815	=100/7.6	KS 24
=100+M-00H3	1	Blitzlicht AC/DC 24V	Telemecanique	M10011814	=100/7.8	XVB L6B5AB
=100-1T1	1	Stromwandler AC 32 500/5A	Langer Messtechnik GmbH	M00000009	=100/8.1	TAC 32 500/5A
=100-1T2	1	Stromwandler AC 32 500/5A	Langer Messtechnik GmbH	M00000009	=100/8.1	TAC 32 500/5A
=100-1T3	1	Stromwandler AC 32 500/5A	Langer Messtechnik GmbH	M00000009	=100/8.1	TAC 32 500/5A
=100-1P1	1	Amperemeter 500/1000/5A	Langer Messtechnik GmbH	M10011872	=100/8.2	RQ 72 E 500/1000/5A
=100-1K01	1	Ueberwachungsrelais 1 Wechsler, 24-240V AC/DC, 0,1-10A AC/DC	Siemens	M10014275	=100/8.3	3UG46 22-2AW30
=100-1F1	1	Ueberwachungsrelais 1,6-16A, 1W, 24-240V AC/DC	Siemens	2374312	=100/8.3	3RR2241-2FW30
=100-1F1	1	Traeger fuer Einzelaufstellung f. 3RU21/3RB30/3RB31 Gr. S00	Siemens	2374313	=100/8.3	3RU2916-3AC01
=100-1KC1	1	Motorschuetz, 90kW/400V 3H, 2S+2OE, 220-240V AC/DC, mit Varistor	Siemens	3RT10 56-2AP36	=100/9.1	3RT10 56-2AP36
=100-1KT1	1	Zeitrelais 24V DC/AC,200...240V AC 1S+1S verzoegert, Cage Clamp	Siemens	M10013725	=100/9.3	3RP15 76-2NP30
=100-1KC2	1	Motorschuetz, 90kW/400V 3H, 2S+2OE, 220-240V AC/DC, mit Varistor	Siemens	3RT10 56-2AP36	=100/9.4	3RT10 56-2AP36
=100-1KC3	1	Motorschuetz, 75kW/400V 3H, 2S+2OE, 220-240V AC/DC, mit Varistor	Siemens	3RT10 55-2AP36	=100/9.6	3RT10 55-2AP36
=100-2Q1	1	Leistungsschalter 4,5-6,3A mit Hilfsschalter,fuer Motorschutz	Siemens	2255703	=100/10.1	3RV2011-1GA15
=100-2Q1	1	OM Adapter 25A,690V, UL 508	Rittal GmbH & Co. KG	SV 9340.310	=100/10.1	SV 9340.310
=100-2Q1	1	Tragschiene 45mm	Rittal GmbH & Co. KG	2196728	=100/10.1	SV 9342.850
=100-2F1	1	SV Reitersicherungselement Typ D 02-E 18	Rittal GmbH & Co. KG	M10011818	=100/10.4	SV 3418.000
=100-2F1	1	Seitliche Abdeckung	Rittal GmbH & Co. KG	M00000008	=100/10.4	SV 3093.000
=100-2F1	3	NEOZED Huelseneinsatz 25A Sockel D02	Lindner	M10021296	=100/10.4	1706.025
=100-2F1	3	NEOZED Sicherungseinsatz 25A D02, 400VAC/250VDC, gL-gG	Lindner	M10006606	=100/10.4	1701.025
=100-2F1	3	NEOZED Schraubkappe Kunststoff D02, 63A, E18, mit Pruefloch	Siemens	5SH4163	=100/10.4	5SH4163
=100-2F1	3	NEOZED Haltefeder 2 - 16 A D02	Lindner	1713.	=100/10.4	1713.
=100-3Q1	1	Leistungsschalter 11-16A mit Hilfsschalter,fuer Motorschutz	Siemens	2255713	=100/10.7	3RV2011-4AA15
=100-3Q1	1	OM Adapter 25A,690V, UL 508	Rittal GmbH & Co. KG	SV 9340.310	=100/10.7	SV 9340.310
=100-3Q1	1	Tragschiene 45mm	Rittal GmbH & Co. KG	2196728	=100/10.7	SV 9342.850
=100-3X1	1	Anbausteckdose 3-pol +N+PE 16A, 415V	Hilpress GmbH	56022	=100/10.7	56022
=100-4Q1	1	Leistungsschalter 27-32A mit Hilfsschalter,fuer Motorschutz	Siemens	3RV2021-4EA15	=100/11.1	3RV2021-4EA15
=100-4Q1	1	OM Adapter 32A,690V	Rittal GmbH & Co. KG	2196715	=100/11.1	SV 9340.460
=100-4Q1	1	Tragschiene 45mm	Rittal GmbH & Co. KG	2196728	=100/11.1	SV 9342.850
=100-4F1	1	Ueberwachungsrelais 4-40A, 1W, 24-240V AC/DC	Siemens	2305008	=100/11.2	3RR2242-2FW30
=100-4F1	1	Traeger fuer Einzelaufstellung f. 3RU21/3RB30/3RB31 Gr. S0	Siemens	2305012	=100/11.2	3RU2926-3AC01
=100-5Q1	1	Leistungsschalter 7-10A mit Hilfsschalter,fuer Motorschutz	Siemens	2255708	=100/11.4	3RV2011-1JA15
=100-5Q1	1	OM Adapter 25A,690V, UL 508	Rittal GmbH & Co. KG	SV 9340.310	=100/11.4	SV 9340.310
=100-5Q1	1	Tragschiene 45mm	Rittal GmbH & Co. KG	2196728	=100/11.4	SV 9342.850
=100-5F1	1	Ueberwachungsrelais 1,6-16A, 1W, 24-240V AC/DC	Siemens	2374312	=100/11.5	3RR2241-2FW30
=100-5F1	1	Traeger fuer Einzelaufstellung f. 3RU21/3RB30/3RB31 Gr. S00	Siemens	2374313	=100/11.5	3RU2916-3AC01
=100-5Q2	1	Leistungsschalter 7-10A mit Hilfsschalter,fuer Motorschutz	Siemens	2255708	=100/11.7	3RV2011-1JA15
=100-5Q2	1	OM Adapter 25A,690V, UL 508	Rittal GmbH & Co. KG	SV 9340.310	=100/11.7	SV 9340.310
=100-5Q2	1	Tragschiene 45mm	Rittal GmbH & Co. KG	2196728	=100/11.7	SV 9342.850
=100-5F2	1	Ueberwachungsrelais 1,6-16A, 1W, 24-240V AC/DC	Siemens	2374312	=100/11.7	3RR2241-2FW30

DATE		04.Dez.2015		KLEEMANN GMBH		 		STUECKLISTE		KLEEMANN SERIES K007		= STK		+	
EDITED		JBR		MOBICAT MC 120 Z EU				KLEEMANN MATERIAL NO 2315434		CAE-SYSTEM: EPLAN 5.70		PG.		3	
MODIFICAT.	DATE	NAME	NORM	DIN	ORIGIN	REP.F.	REP.T.					PG.		13	

# Part's list

TPLSTK05 12.10.2015

Component designation	Amount	DESIGNATION	Manufacturer	Article number	Page/Path	Model number
=100-5F2	1	Traeger fuer Einzelaufstellung f. 3RU21/3RB30/3RB31 Gr. S00	Siemens	2374313	=100/11.7	3RU2916-3AC01
=100-6Q1	1	Leistungsschalter 11-16A mit Hilfsschalter,fuer Motorschutz	Siemens	2255713	=100/12.1	3RV2011-4AA15
=100-6Q1	1	OM Adapter 25A,690V, UL 508	Rittal GmbH & Co. KG	SV 9340.310	=100/12.1	SV 9340.310
=100-6Q1	1	Tragschiene 45mm	Rittal GmbH & Co. KG	2196728	=100/12.1	SV 9342.850
=100-7F1	1	SV Reitersicherungselement Typ D 02-E 18	Rittal GmbH & Co. KG	M10011818	=100/12.4	SV 3418.000
=100-7F1	1	Seitliche Abdeckung	Rittal GmbH & Co. KG	M00000008	=100/12.4	SV 3093.000
=100-7F1	3	Sicherungseinsatz 63A D02, 400VAC/250VDC, gL-gG	Lindner	M10009493	=100/12.4	1701.063
=100-7F1	3	NEOZED Schraubkappe Kunststoff D02, 63A, E18, mit Pruefloch	Siemens	5SH4163	=100/12.4	5SH4163
=100-7F1	3	NEOZED Haltefeder 2 - 16 A D02	Lindner	1713.	=100/12.4	1713.
=100-7F2	1	Ueberwachungsrelais 4-40A, 1W, 24-240V AC/DC	Siemens	2305008	=100/12.4	3RR2242-2FW30
=100-7F2	1	Traeger fuer Einzelaufstellung f. 3RU21/3RB30/3RB31 Gr. S0	Siemens	2305012	=100/12.4	3RU2926-3AC01
=100-9Q1	1	Leistungsschalter 7-10A mit Hilfsschalter,fuer Motorschutz	Siemens	2255708	=100/13.1	3RV2011-1JA15
=100-9Q1	1	OM Adapter 25A,690V, UL 508	Rittal GmbH & Co. KG	SV 9340.310	=100/13.1	SV 9340.310
=100-9Q1	1	Tragschiene 45mm	Rittal GmbH & Co. KG	2196728	=100/13.1	SV 9342.850
=100-10Q1	1	Leistungsschalter 4,5-6,3A mit Hilfsschalter,fuer Motorschutz	Siemens	2255703	=100/13.4	3RV2011-1GA15
=100-10Q1	1	OM Adapter 32A,690V, UL 508	Rittal GmbH & Co. KG	M10025431	=100/13.4	SV 9340.510
=100-10Q1	1	Tragschiene 45mm	Rittal GmbH & Co. KG	2196728	=100/13.4	SV 9342.850
=100-13Q1	1	Leistungsschalter 0,28-0,4A mit Hilfsschalter,fuer Motorschutz	Siemens	2255735	=100/13.7	3RV2011-0EA15
=100-13Q1	1	OM Adapter 25A,690V, UL 508	Rittal GmbH & Co. KG	SV 9340.310	=100/13.7	SV 9340.310
=100-8Q1	1	Steuerschalter 4-pol 12kW 400V 32A	Moeller	M10013874	=100/14.1	T3-4-8223/E
=100-8A1	1	Frequenzumrichter 380-480V, 25/29A, 50-60Hz, 11/15kW	Control Techniques	M20000268	=100/14.2	SK 2403
=100-8F1	1	SV Reitersicherungselement Typ D 02-E 18	Rittal GmbH & Co. KG	M10011818	=100/14.2	SV 3418.000
=100-8F1	1	Seitliche Abdeckung	Rittal GmbH & Co. KG	M00000008	=100/14.2	SV 3093.000
=100-8F1	3	NEOZED Huelseneinsatz 35A Sockel D02	Lindner	M10021297	=100/14.2	1706.035
=100-8F1	3	NEOZED Sicherungseinsatz 35A D02, 400VAC/250VDC, gL-gG	Lindner	M10006607	=100/14.2	1701.035
=100-8F1	3	NEOZED Schraubkappe Kunststoff D02, 63A, E18, mit Pruefloch	Siemens	5SH4163	=100/14.2	5SH4163
=100-8F1	3	NEOZED Haltefeder 2 - 16 A D02	Lindner	1713.	=100/14.2	1713.
=100-8L1	1	Netzdrossel 28,8A, max.600V 50-60Hz	Control Techniques	KDD 0,4/N/600V/28,8A/4UK	=100/14.2	KDD 0,4/N/600V/28,8A/4UK
=100-8F2	1	Ueberlastrelais 7-10A, 1S+1OE f.Einzelaufstellung	Siemens	2255404	=100/14.2	3RU2116-1JC1
=100-8F3	1	Ueberlastrelais 7-10A, 1S+1OE f.Einzelaufstellung	Siemens	2255404	=100/14.4	3RU2116-1JC1
=100-8RB	1	Bremswiderstand SP 100W 400V 37,5 Ohm	Control Techniques	M10020877	=100/14.7	SP
=100-SC	1	Knebel 2 Schalterstellungen, verrastend, schwarz, 1S	Siemens	M10021302	=100/17.1	3SB32 02-2KA11-0CC0
=100-SC	1	Schildtraeger	Siemens	3SB39 25-0AV	=100/17.1	3SB39 25-0AV
=100-SC	1	IVS-Hutschienenadapter	Klöckner Moeller	M10018771	=100/17.1	M22-IVS
=100-A0_OP	1	Operator Panel 256kB Anwenderspeicher, 24V DC	VIPA GmbH	M10019119	=100/17.2	OP 03 603-10P00
=100-A_FW	1	Fernwartungssystem	MB Connect Line	M20000333	=100/17.2	MDH 513
=100-A_FW	1	Verbindungskabel	MB Connect Line	8248	=100/17.2	8248
=100-A_FW	1	MPI Verbindungskabel 1,2m	MB Connect Line	KS 1.2/9	=100/17.2	KS 1.2/9
=100-A0_CPU	1	SPS-CPU mit MPI 256 Zaehler, 96kByte RAM	VIPA GmbH	2302910	=100/17.2	VIPA 214-1BA03
=100-A0_CPU	1	Busverbinder 4-fach	VIPA GmbH	290-0AA40	=100/17.2	290-0AA40
=100-A0_CPU	1	Busverbinder 8-fach	VIPA GmbH	290-0AA80	=100/17.2	290-0AA80
=100-A0_2	1	Ein-/ausgabebaugruppe SM 238 12DE+4DIO,3AE+1Pt100,2AA,24V DC	VIPA GmbH	M10020887	=100/17.2	SM 238-2BC00
=100-A0_3	1	Digitalausgabebaugruppe SM 222 16DO, 24V DC, 1A	VIPA GmbH	M10021058	=100/17.4	SM 222-1BH10
=100-A0_4	1	Digitaleingabebaugruppe SM 221 32DE, 24VDC	VIPA GmbH	M10021059	=100/17.4	SM 221-2BL10
=100-A0_5	1	Digitaleingabebaugruppe SM 221 32DE, 24VDC	VIPA GmbH	M10021059	=100/17.5	SM 221-2BL10
=100-A0_6	1	Digitalausgabebaugruppe SM 222 32DO, 24V DC, 1A	VIPA GmbH	M10021060	=100/17.6	SM 222-2BL10
=100-1K1	1	Stecksockel mit Relais 2 Wechsler 250V AC/8A Spule 24V DC	Wago GmbH & Co. KG	M10019133 + M10019138	=100/22.1	788-312
=100-1K08	1	Schuetz, 3kW/400V 3H 1OE 24V DC, Cage-Clamp	Siemens	2256178	=100/22.5	3RT2015-2BB42
=100-2KC1	1	Schuetz, 3kW/400V 3H 1OE 24V DC, Cage-Clamp	Siemens	2256178	=100/23.1	3RT2015-2BB42
=100-2KC2	1	Schuetz, 3kW/400V 3H 1OE 24V DC, Cage-Clamp	Siemens	2256178	=100/23.2	3RT2015-2BB42

DATE 04.Dez.2015		KLEEMANN GMBH		 	STUECKLISTE		KLEEMANN SERIES K007		= STK	+
EDITED JBR		MOBICAT MC 120 Z EU					KLEEMANN MATERIAL NO 2315434		CAE-SYSTEM: EPLAN 5.70	PG. 4
MODIFICAT.	DATE	NAME	NORM	DIN	ORIGIN	REP.F.	REP.T.			PG. 13

# Part's list

TPLSTK05 12.10.2015

Component designation	Amount	DESIGNATION	Manufacturer	Article number	Page/Path	Model number
=100-3KC1	1	Schuetz, 5,5kW/400V 3H 1S 24V DC, Cage-Clamp	Siemens	2256190	=100/23.3	3RT2017-2BB41
=100-2KC3	1	Schuetz, 11kW/400V 3H 1S+1OE 24V DC, Cage-Clamp	Siemens	2256200	=100/23.4	3RT2026-2BB40
=100-4KC1	1	Schuetz 15kW/400V 3H 1S+1OE, 24V DC, ohne Varistor,	Siemens	2268888	=100/23.5	3RT2027-2BB40
=100-5KC1	1	Schuetz, 4kW/400V 3H 1S 24V DC, Cage-Clamp	Siemens	2256186	=100/23.6	3RT2016-2BB41
=100-5KC2	1	Schuetz, 4kW/400V 3H 1S 24V DC, Cage-Clamp	Siemens	2256186	=100/23.7	3RT2016-2BB41
=100-6KC1	1	Schuetz, 5,5kW/400V 3H 1S 24V DC, Cage-Clamp	Siemens	2256190	=100/23.8	3RT2017-2BB41
=100-S0.0	1	Leuchtdrucktaster weiss, LED integriert flacher Druckknopf 1S, UC 24V	Siemens	2219470	=100/24.1	3SB32 45-0AA61-0CC0
=100-S0.0	1	Schutzkappe für Drucktaster flach	Siemens	3SB39 21-0AH	=100/24.1	3SB39 21-0AH
=100-S0.0	1	Schildtraeger 3SB39 25-0AV	Siemens	3SB39 25-0AV	=100/24.1	3SB39 25-0AV
=100-S0.1	1	Drucktaster rot flacher Druckknopf 1OE	Siemens	2219480	=100/24.2	3SB32 03-0AA21-0CC0
=100-S0.1	1	Schutzkappe für Drucktaster flach	Siemens	3SB39 21-0AH	=100/24.2	3SB39 21-0AH
=100-S0.1	1	Schildtraeger 3SB39 25-0AV	Siemens	3SB39 25-0AV	=100/24.2	3SB39 25-0AV
=100-S0.2	1	Knebel 2 Schalterstellungen, verrastend, schwarz, 1S	Siemens	M10021302	=100/24.3	3SB32 02-2KA11-0CC0
=100-S0.2	1	Schutzkappe für Knebel	Siemens	3SB39 21-0BA	=100/24.3	3SB39 21-0BA
=100-S0.2	1	Schildtraeger 3SB39 25-0AV	Siemens	3SB39 25-0AV	=100/24.3	3SB39 25-0AV
=100-S0.3	1	Drucktaster blau flacher Druckknopf, 1S	Siemens	3SB32 02-0AA51-0CC0	=100/24.4	3SB32 02-0AA51-0CC0
=100-S0.3	1	Schutzkappe für Drucktaster flach	Siemens	3SB39 21-0AH	=100/24.4	3SB39 21-0AH
=100-S0.3	1	Schildtraeger 3SB39 25-0AV	Siemens	3SB39 25-0AV	=100/24.4	3SB39 25-0AV
=100-S0.4	1	Leuchtdrucktaster rot, LED integriert flacher Druckknopf 1Ö, UC 24V	Siemens	2219472	=100/24.5	3SB32 46-0AA21-0CC0
=100-S0.4	2	Schaltelement mit 1 Schaltglied 1S	Siemens	M10017540	=100/24.5	3SB34 03-0B
=100-S0.4	1	Schutzkappe für Drucktaster flach	Siemens	3SB39 21-0AH	=100/24.5	3SB39 21-0AH
=100-S0.4	1	Schildtraeger 3SB39 25-0AV	Siemens	3SB39 25-0AV	=100/24.5	3SB39 25-0AV
=100-2S2	1	Knebel 3 Schalterstellungen, schwarz, 1S, 1S	Siemens	3SB32 10-2DA11-0CC0	=100/24.6	3SB32 10-2DA11-0CC0
=100-2S2	1	Schaltelement 1OE Einbautiefe 50mm	Siemens	M10017539	=100/24.6	3SB34 03-0C
=100-2S2	1	Schutzkappe für Knebel	Siemens	3SB39 21-0BA	=100/24.6	3SB39 21-0BA
=100-2S2	1	Schildtraeger 3SB39 25-0AV	Siemens	3SB39 25-0AV	=100/24.6	3SB39 25-0AV
=100-2S1	1	Leuchtdrucktaster gruen, LED integriert flacher Druckknopf 1S, UC 24V	Siemens	M10020706	=100/24.7	3SB32 45-0AA41-0CC0
=100-2S1	1	Schutzkappe für Drucktaster flach	Siemens	3SB39 21-0AH	=100/24.7	3SB39 21-0AH
=100-2S1	1	Schildtraeger 3SB39 25-0AV	Siemens	3SB39 25-0AV	=100/24.7	3SB39 25-0AV
=100-3S1	1	Leuchtdrucktaster gruen, LED integriert flacher Druckknopf 1S, UC 24V	Siemens	M10020706	=100/24.8	3SB32 45-0AA41-0CC0
=100-3S1	1	Schutzkappe für Drucktaster flach	Siemens	3SB39 21-0AH	=100/24.8	3SB39 21-0AH
=100-3S1	1	Schildtraeger 3SB39 25-0AV	Siemens	3SB39 25-0AV	=100/24.8	3SB39 25-0AV
=100-4S1	1	Leuchtdrucktaster gruen, LED integriert flacher Druckknopf 1S, UC 24V	Siemens	M10020706	=100/25.1	3SB32 45-0AA41-0CC0
=100-4S1	1	Schutzkappe für Drucktaster flach	Siemens	3SB39 21-0AH	=100/25.1	3SB39 21-0AH
=100-4S1	1	Schildtraeger 3SB39 25-0AV	Siemens	3SB39 25-0AV	=100/25.1	3SB39 25-0AV
=100-5S1	1	Leuchtdrucktaster gruen, LED integriert flacher Druckknopf 1S, UC 24V	Siemens	M10020706	=100/25.2	3SB32 45-0AA41-0CC0
=100-5S1	1	Schutzkappe für Drucktaster flach	Siemens	3SB39 21-0AH	=100/25.2	3SB39 21-0AH
=100-5S1	1	Schildtraeger 3SB39 25-0AV	Siemens	3SB39 25-0AV	=100/25.2	3SB39 25-0AV
=100-6S1	1	Leuchtdrucktaster gruen, LED integriert flacher Druckknopf 1S, UC 24V	Siemens	M10020706	=100/25.3	3SB32 45-0AA41-0CC0
=100-6S1	1	Schutzkappe für Drucktaster flach	Siemens	3SB39 21-0AH	=100/25.3	3SB39 21-0AH
=100-6S1	1	Schildtraeger 3SB39 25-0AV	Siemens	3SB39 25-0AV	=100/25.3	3SB39 25-0AV
=100-7S1	1	Leuchtdrucktaster gruen, LED integriert flacher Druckknopf 1S, UC 24V	Siemens	M10020706	=100/25.4	3SB32 45-0AA41-0CC0
=100-7S1	1	Schutzkappe für Drucktaster flach	Siemens	3SB39 21-0AH	=100/25.4	3SB39 21-0AH
=100-7S1	1	Schildtraeger 3SB39 25-0AV	Siemens	3SB39 25-0AV	=100/25.4	3SB39 25-0AV
=100-8S1	1	Leuchtdrucktaster gruen, LED integriert flacher Druckknopf 1S, UC 24V	Siemens	M10020706	=100/25.5	3SB32 45-0AA41-0CC0
=100-8S1	1	Schutzkappe für Drucktaster flach	Siemens	3SB39 21-0AH	=100/25.5	3SB39 21-0AH
=100-8S1	1	Schildtraeger 3SB39 25-0AV	Siemens	3SB39 25-0AV	=100/25.5	3SB39 25-0AV
=100-10S1	1	Leuchtdrucktaster gruen, LED integriert flacher Druckknopf 1S, UC 24V	Siemens	M10020706	=100/25.7	3SB32 45-0AA41-0CC0
=100-10S1	1	Schutzkappe für Drucktaster flach	Siemens	3SB39 21-0AH	=100/25.7	3SB39 21-0AH
=100-10S1	1	Schildtraeger 3SB39 25-0AV	Siemens	3SB39 25-0AV	=100/25.7	3SB39 25-0AV

DATE 04.Dez.2015		KLEEMANN GMBH		 	STUECKLISTE		KLEEMANN SERIES K007		= STK		+	
EDITED JBR		MOBICAT MC 120 Z EU					KLEEMANN MATERIAL NO 2315434		CAE-SYSTEM: EPLAN 5.70		PG. 5	
MODIFICAT.	DATE	NAME	NORM	DIN	ORIGIN	REP.F.	REP.T.			PG. 13		

# Part's list

TPLSTK05 12.10.2015

Component designation	Amount	DESIGNATION	Manufacturer	Article number	Page/Path	Model number
=100-9S1	1	Leuchtdrucktaster gruen, LED integriert	flacher Druckknopf 1S, UC 24V	Siemens	M10020706	=100/26.4 3SB32 45-0AA41-0CC0
=100-9S1	1	Schutzkappe	für Drucktaster flach	Siemens	3SB39 21-0AH	=100/26.4 3SB39 21-0AH
=100-9S1	1	Schildtraeger		Siemens	3SB39 25-0AV	=100/26.4 3SB39 25-0AV
=100-S5.2	1	Leuchtdrucktaster gelb, LED integriert	flacher Druckknopf 1S, UC 24V	Siemens	3SB32 45-0AA31-0CC0	=100/29.3 3SB32 45-0AA31-0CC0
=100-S5.2	1	Schutzkappe	für Drucktaster flach	Siemens	3SB39 21-0AH	=100/29.3 3SB39 21-0AH
=100-S5.2	1	Schildtraeger		Siemens	3SB39 25-0AV	=100/29.3 3SB39 25-0AV
=100+-8S	1	Knebel 3 Schalterstellungen,	schwarz, 1S, 1S	Siemens	M10021301	=100/29.7 3SB32 10-2EA11-0CC0
=100+-8S	1	Schutzkappe	für Knebel	Siemens	3SB39 21-0BA	=100/29.7 3SB39 21-0BA
=100+-8S	1	Schildtraeger		Siemens	3SB39 25-0AV	=100/29.7 3SB39 25-0AV
=100-7KC1	1	Schuetz 15kW/400V	3H 1S+1OE, 24V DC, ohne Varistor,	Siemens	2268888	=100/32.1 3RT2027-2BB40
=100-8KC1	1	Schuetz 15kW/400V	3H 1S+1OE, 24V DC, ohne Varistor,	Siemens	2268888	=100/32.2 3RT2027-2BB40
=100-9KC1	1	Schuetz, 5,5kW/400V	3H 1S 24V DC, Cage-Clamp	Siemens	2256190	=100/32.3 3RT2017-2BB41
=100-10KC1	1	Schuetz, 3kW/400V	3H 1S 24V DC, Cage-Clamp	Siemens	2256180	=100/32.4 3RT2015-2BB41
=100-00K2	1	Stecksocket mit Relais	2 Wechsler 250V AC/8A Spule 24V DC	Wago GmbH & Co. KG	M10019133 + M10019138	=100/32.7 788-312
=100-00K3	1	Stecksocket mit Relais	2 Wechsler 250V AC/8A Spule 24V DC	Wago GmbH & Co. KG	M10019133 + M10019138	=100/32.8 788-312
=100-8K2	1	Stecksocket mit Relais	2 Wechsler 250V AC/8A Spule 24V DC	Wago GmbH & Co. KG	M10019133 + M10019138	=100/33.2 788-312
=100-0H6	1	Leuchtmelder blau, mit glatter Linse	LED integriert, 24V	Siemens	3SB32 44-6AA50-0CC0	=100/33.8 3SB32 44-6AA50-0CC0
=100-0H6	1	Schildtraeger		Siemens	3SB39 25-0AV	=100/33.8 3SB39 25-0AV
=100-0H2	1	Leuchtmelder weiss, mit glatter Linse	LED integriert, 24V	Siemens	3SB32 44-6AA60-0CC0	=100/34.2 3SB32 44-6AA60-0CC0
=100-0H2	1	Schildtraeger		Siemens	3SB39 25-0AV	=100/34.2 3SB39 25-0AV
=100-0H2.1	1	Leuchtmelder weiss, mit glatter Linse	LED integriert, 24V	Siemens	3SB32 44-6AA60-0CC0	=100/34.3 3SB32 44-6AA60-0CC0
=100-0H2.1	1	Schildtraeger		Siemens	3SB39 25-0AV	=100/34.3 3SB39 25-0AV
=100-LS1	1	Knebel 2 Schalterstellungen,	verrastend, schwarz, 1S	Siemens	M10021302	=100/36.1 3SB32 02-2KA11-0CC0
=100-LS1	1	Schutzkappe	für Knebel	Siemens	3SB39 21-0BA	=100/36.1 3SB39 21-0BA
=100-LS1	1	Schildtraeger		Siemens	3SB39 25-0AV	=100/36.1 3SB39 25-0AV
=100-LS1	1	Socket fuer Relais LZX:MT32...		Siemens	M10010285	=100/36.2 LZX:MT78750
=100-GA1	1	Schlüsselschaltgeraet		AVS Aggregatebau	M10011598	=100/37.0 K26MUE_KSE_72
=100-GF1	1	2-Leiter-Sicherungsklemme, grau	8mm breit, Cage Clamp	Wago GmbH & Co. KG	M10015067	=100/37.0 282-696
=100-GF1	1	Abschluss- und Zwischenplatte, orange	2mm dick	Wago GmbH & Co. KG	M10015068	=100/37.0 282-333
=100-GK1	1	Stecksocket mit Relais	2 Wechsler 250V AC/8A Spule 24V DC	Wago GmbH & Co. KG	M10019133 + M10019138	=100/37.1 788-312
=100-GK61	1	Stecksocket mit Relais	2 Wechsler 250V AC/8A Spule 24V DC	Wago GmbH & Co. KG	M10019133 + M10019138	=100/37.2 788-312
=100-GK6	1	Stecksocket mit Relais	2 Wechsler 250V AC/8A Spule 24V DC	Wago GmbH & Co. KG	M10019133 + M10019138	=100/37.3 788-312
=100-GK9	1	Stecksocket mit Relais	2 Wechsler 250V AC/8A Spule 24V DC	Wago GmbH & Co. KG	M10019133 + M10019138	=100/37.6 788-312
=100-GK9.1	1	Stecksocket mit Relais	2 Wechsler 250V AC/8A Spule 24V DC	Wago GmbH & Co. KG	M10019133 + M10019138	=100/37.7 788-312
=100-GK26	1	Stecksocket mit Relais	2 Wechsler 250V AC/8A Spule 24V DC	Wago GmbH & Co. KG	M10019133 + M10019138	=100/38.2 788-312
=100-GKT1	1	Zeitrelais mit LED	1 Wechsler, Cage Clamp	Siemens	M10014285	=100/38.3 3RP15 25-2AP30
=100-GP1	1	Oeldruckmesser elektrisch, rund	0-10bar	Motometer	M10014439	=100/40.1 644 060 1026
=100-GP2	1	Temperaturanzeige elektrisch, rund	40-120°C	Motometer	M10014440	=100/40.2 641 012 1060
=100-GP3	1	Tankanzeige elektrisch, rund D=64mm		Motometer	M10019161	=100/40.4 609 060 1039
=100-GKT2	1	Zeitrelais mit LED	1 Wechsler, Cage Clamp	Siemens	M10014285	=100/40.6 3RP15 25-2AP30
=100-SN0	1	Knebel 2 Schalterstellungen,	verrastend, schwarz, 1S	Siemens	M10021302	=100/41.1 3SB32 02-2KA11-0CC0
=100-SN0	2	Schaltelement 1OE	Einbautiefe 50mm	Siemens	M10017539	=100/41.1 3SB34 03-0C
=100-SN0	1	Schutzkappe	für Knebel	Siemens	3SB39 21-0BA	=100/41.1 3SB39 21-0BA
=100-SN0	1	Schildtraeger		Siemens	3SB39 25-0AV	=100/41.1 3SB39 25-0AV
=100-KGA1	1	Hilfsschuetz SIRIUS	2S+2OE 24VDC, Cage Clamp	Siemens	2256202	=100/41.2 3RH2122-2BB40
=100-KGA2	1	Stecksocket mit Relais	2 Wechsler 250V AC/8A Spule 24V DC	Wago GmbH & Co. KG	M10019133 + M10019138	=100/41.2 788-312
=100-KGA3	1	Stecksocket mit Relais	2 Wechsler 250V AC/8A Spule 24V DC	Wago GmbH & Co. KG	M10019133 + M10019138	=100/41.3 788-312
=100-8K04	1	Stecksocket mit Relais	2 Wechsler 250V AC/8A Spule 24V DC	Wago GmbH & Co. KG	M10019133 + M10019138	=100/41.4 788-312
=100-8K03	1	Stecksocket mit Relais	2 Wechsler 250V AC/8A Spule 24V DC	Wago GmbH & Co. KG	M10019133 + M10019138	=100/41.4 788-312

DATE	04.Dez.2015	KLEEMANN GMBH	 	STUECKLISTE	KLEEMANN SERIES	K007	= STK	+
EDITED	JBR	MOBICAT MC 120 Z EU		KLEEMANN MATERIAL NO	2315434	CAE-SYSTEM: EPLAN 5.70	PG.	6
CONTR.	D. MALLKOWSKY	ORIGIN	REP.F.	REP.T.			PG.	13
MODIFICAT.	DATE	NAME	NORM	DIN				

# Part's list

TPLSTK05 12.10.2015

Component designation	Amount	DESIGNATION	Manufacturer	Article number	Page/Path	Model number
-XOUT	1	Attachment housing 16-pol. with 2 bow	ILME GmbH	M10020941	=A0/19.6	CHI 16
-XOUT	1	Plug housing M25 with Bolt for 2 Bow	ILME GmbH	M10011806	=A0/19.6	MHO 16.25
-XOUT	1	Socket insert 16-poled+pe 16A max, 400V	ILME GmbH	M10011811	=A0/19.6	CNF 16
-XOUT	1	Pin insert 16-pol+pe 16A max, 500V	ILME GmbH	M10011812	=A0/19.6	CSEM 16
-3X2	1	Plug housing 4-pol.+pe with bow and screwing, metal	ILME GmbH	M10011803	=A0/19.6	CKA 03 VGS
-3X2	1	Pin insert 4-pol+pe 10A max, 250V	ILME GmbH	M10011804	=A0/19.6	CKM 04
-3X2	1	Socket insert 4-pol+pe 10A max, 250V	ILME GmbH	M10011805	=A0/19.6	CKF 04
-4X1	1	Pin insert 4+2-pol +PE 80A max+16A max, 400V	ILME GmbH	M10012918	=A0/19.6	CXM 4/2
-4X1	1	Socket insert 4+2-pol +PE 80A max+16A max, 400V	ILME GmbH	M10012917	=A0/19.6	CXF 4/2
-4X1	1	Attachment housing 16-pol. with 2 bow	ILME GmbH	M10020941	=A0/19.6	CHI 16
-4X1	1	Plug housing M32 with Bolt for 2 Bow	ILME GmbH	MHO 16.32	=A0/19.6	MHO 16.32
-4X2	1	Pin insert 4-pol+pe 10A max, 250V	ILME GmbH	M10011804	=A0/19.6	CKM 04
-4X2	1	Socket insert 4-pol+pe 10A max, 250V	ILME GmbH	M10011805	=A0/19.6	CKF 04
-4X2	1	Add-on housing without Cable outlet	ILME GmbH	CKAX 03 IA	=A0/19.6	2454383
-4X2	1	Plug housing with Bolt	ILME GmbH	MKA V20	=A0/19.6	M10011803
=100-0P1	1	Ammeter 800/1600/5a	Langer Messtechnik GmbH	M10009940	=100/1.0	RQ 72 E 800/1600/5A
=100-0T02	1	Summation current transformer 500ma for FAULT CURRENT-Relay Type MFR	Doepke	MFIW 105/0,5	=100/1.1	MFIW 105/0,5
=100-0Q1	1	Power switch 3p 630a bg3 NZMN3-AI630	Moeller	M10017488	=100/1.1	NZMN3-AE630
=100-0Q1	1	Undervoltage circuit breaker with 2 vhi NZM2/3-XUHV380-440AC	Moeller	M10017491	=100/1.1	NZM2/3-XUHV380-440AC
=100-0Q1	1	Main switch kit f. NZM3(-4), PN3(-4), N3(-4)	Moeller	M10017494	=100/1.1	NZM3-XHBR
=100-0Q1	1	Contact element 1S Front M22-CK10	Moeller	M10016214	=100/1.1	M22-CK10
=100-0T01	1	Current transformer ac 40 800/5A	Langer Messtechnik GmbH	M00000010	=100/1.1	TAC 40 800/5A
=100-0F00	1	NEOZED FUSE BASE, 3-POL, D01, 16A, E14,W.INSULATING COVER	Lindner	2734.	=100/1.2	2734.
=100-0F00	2	NEOZED Screw cap Plastic D01,16A, E14,W.TEST HOLE	Siemens	5SH4116	=100/1.2	5SH4116
=100-0F00	2	FUSE LINK D01, 2A NEOZED 400VAC/250VDC, gL-gG	Lindner	M10006604	=100/1.2	1700.002
=100-0F00	2	SLEEVE-TYPE GAUGE RING OF THE FUSE NEOZED 2A Base d01	Lindner	M10021286	=100/1.2	1705.002
=100-PE	2	Busbar holder 1pol	Rittal GmbH & Co. KG	SV 9340.030	=100/1.2	SV 9340.030
=100-0F01	1	RESIDUAL CURRENT DEVICE 2NO, 500V, 16A	Doepke	M10016345	=100/1.3	MFR
=100-0F09	1	NEOZED Screw cap Plastic D01,16A, E14,W.TEST HOLE	Siemens	5SH4116	=100/1.4	5SH4116
=100-0F09	1	SLEEVE-TYPE GAUGE RING OF THE FUSE NEOZED 2A Base d01	Lindner	M10021286	=100/1.4	1705.002
=100-0F09	1	FUSE LINK D01, 2A NEOZED 400VAC/250VDC, gL-gG	Lindner	M10006604	=100/1.4	1700.002
=100-P5	1	Operating hour meter 230v ac	ABB AG	M10011840	=100/1.4	E233-230
=100-0F06	1	NEOZED FUSE BASE, 1-POL, D01, 16A, E14,W.INSULATING COVER	Lindner	2724.	=100/3.1	2724.
=100-0F06	1	NEOZED Screw cap Plastic D01,16A, E14,W.TEST HOLE	Siemens	5SH4116	=100/3.1	5SH4116
=100-0F06	1	FUSE LINK D01, 6A NEOZED 400VAC/250VDC, gL-gG	Lindner	M10004051	=100/3.1	1700.006
=100-0F06	1	SLEEVE-TYPE GAUGE RING OF THE FUSE NEOZED 6A Base d01	Lindner	M10021288	=100/3.1	1705.006
=100-0F07	1	NEOZED FUSE BASE, 1-POL, D01, 16A, E14,W.INSULATING COVER	Lindner	2724.	=100/3.3	2724.
=100-0F07	1	NEOZED Screw cap Plastic D01,16A, E14,W.TEST HOLE	Siemens	5SH4116	=100/3.3	5SH4116
=100-0F07	1	FUSE LINK D01, 6A NEOZED 400VAC/250VDC, gL-gG	Lindner	M10004051	=100/3.3	1700.006
=100-0F07	1	SLEEVE-TYPE GAUGE RING OF THE FUSE NEOZED 6A Base d01	Lindner	M10021288	=100/3.3	1705.006
=100-0F08	1	NEOZED FUSE BASE, 1-POL, D01, 16A, E14,W.INSULATING COVER	Lindner	2724.	=100/3.5	2724.
=100-0F08	1	NEOZED Screw cap Plastic D01,16A, E14,W.TEST HOLE	Siemens	5SH4116	=100/3.5	5SH4116
=100-0F08	1	FUSE LINK D01, 6A NEOZED 400VAC/250VDC, gL-gG	Lindner	M10004051	=100/3.5	1700.006
=100-0F08	1	SLEEVE-TYPE GAUGE RING OF THE FUSE NEOZED 6A Base d01	Lindner	M10021288	=100/3.5	1705.006
=100-SX	1	Handle 2 switch positions, locking, black, 1no	Siemens	M10021302	=100/3.7	3SB32 02-2KA11-0CC0
=100-SX	1	Protecting cap for Handle	Siemens	3SB39 21-0BA	=100/3.7	3SB39 21-0BA
=100-SX	1	Tag holder	Siemens	3SB39 25-0AV	=100/3.7	3SB39 25-0AV
=100-KX	1	Plug-in base w. relay 2 changeover contact 250V AC/8A coil 24V DC	Wago GmbH & Co. KG	M10019133 + M10019138	=100/3.7	788-312
=100-0F03	1	NEOZED FUSE BASE, 3-POL, D02, 63A, E18,W.INSULATING COVER	Lindner	2735.	=100/4.1	2735.
=100-0F03	3	NEOZED Screw cap Plastic D02, 63A, E18,W.TEST HOLE	Siemens	5SH4163	=100/4.1	5SH4163

DATE		04.Dez.2015		KLEEMANN GMBH		 		PART'S LIST		KLEEMANN SERIES K007		= STK		+	
EDITED		JBR		MOBICAT MC 120 Z EU						KLEEMANN MATERIAL NO 2315434		CAE-SYSTEM: EPLAN 5.70		PG. 7	
CONTR.		D. MALLKOWSKY												PG. 13	
MODIFICAT.	DATE	NAME	NORM	DIN	ORIGIN	REP.F.	REP.T.								



# Part's list

TPLSTK05 12.10.2015

Component designation	Amount	DESIGNATION	Manufacturer	Article number	Page/Path	Model number
=100-0F03	3	FUSE LINK 35A NEOZED	D02, 400VAC/250VDC, GL-GG	Lindner	M10006607	=100/4.1 1701.035
=100-0F03	3	SLEEVE-TYPE GAUGE RING OF THE FUSE NEOZED 35A	Base d02	Lindner	M10021297	=100/4.1 1706.035
=100-0F04	1	RESIDUAL CURRENT DEVICE	400V 40A/30ma	Legrand	M10025396	=100/4.1 DX 40A 40/0,03
=100-0X4	1	Assembly socket	5-pol 32A, 400V	Hilpress GmbH	56024	=100/4.1 56024
=100-0F05	1	NEOZED FUSE BASE, 1-POL,	D01, 16A, E14,W.INSULATING COVER	Lindner	2724.	=100/4.3 2724.
=100-0F05	1	NEOZED Screw cap Plastic	D01,16A, E14,W.TEST HOLE	Siemens	5SH4116	=100/4.3 5SH4116
=100-0F05	1	FUSE LINK D01, 16A NEOZED	400VAC/250VDC, gL-gG	Lindner	M10006605	=100/4.3 1700.016
=100-0X5	1	Assembly socket	2-pol 16A, 250V	Hilpress GmbH	M10009114	=100/4.3 56090
=100-0F0	1	NH-Fuse-switch-disconnector Gr.00	160A, 690V	Rittal GmbH & Co. KG	SV 9343.010	=100/5.1 SV 9343.010
=100-0F0	3	NH-Fuse link Gr.000 100A	500V AC/250V DC/gL/gg	Siemens	3NA7 830	=100/5.1 3NA7 830
=100-0X1	1	Socket ad385x5s	5-pol 125A, 400V	ELSPRO GmbH	M10011844	=100/5.1 AD385X5S
=100-0F1	1	FUSE ELEMENT SV	Typ d 02-e 18	Rittal GmbH & Co. KG	M10011818	=100/5.4 SV 3418.000
=100-0F1	1	Side covering		Rittal GmbH & Co. KG	M00000008	=100/5.4 SV 3093.000
=100-0F1	2	SLEEVE-TYPE GAUGE RING OF THE FUSE NEOZED 10A	Base d02	Lindner	M10021293	=100/5.4 1706.01
=100-0F1	2	FUSE LINK D01, 10A NEOZED	400VAC/250VDC, gL-gG	Lindner	M10004052	=100/5.4 1700.01
=100-0F1	2	NEOZED Screw cap Plastic	D02, 63A, E18,W.TEST HOLE	Siemens	5SH4163	=100/5.4 5SH4163
=100-0F1	2	NEOZED Locking spring 2 - 16 A	D02	Lindner	1713.	=100/5.4 1713.
=100-0T1	1	Transformer 1-phase 500va	prim. 400V/1,36A sec. 230V/2,2A	Block GmbH & Co.KG	M00000014	=100/5.4 ST 500/4/23
=100-0F1.3	1	Automatic circuit breaker one-pole type c	2A 400V AC/220V DC	Siemens	M10019972	=100/5.4 5SY6 102-7
=100-0F1.3	1	Auxiliary switch 1no 1nc	for ls-switch d=70mm	Siemens	M10019130	=100/5.4 5ST3 010
=100-0F02	1	FUSE ELEMENT SV	Typ d 02-e 18	Rittal GmbH & Co. KG	M10011818	=100/5.7 SV 3418.000
=100-0F02	1	Contact-voltage proof covering	Typ d 02-e 18	Rittal GmbH & Co. KG	SV 3419.000	=100/5.7 SV 3419.000
=100-0F02	1	Side covering		Rittal GmbH & Co. KG	M00000008	=100/5.7 SV 3093.000
=100-0F02	2	FUSE LINK D01, 2A NEOZED	400VAC/250VDC, gL-gG	Lindner	M10006604	=100/5.7 1700.002
=100-0F02	2	SLEEVE-TYPE GAUGE RING OF THE FUSE NEOZED 2A	Base d02	Lindner	M10021290	=100/5.7 1706.002
=100-0F02	2	NEOZED Screw cap Plastic	D02, 63A, E18,W.TEST HOLE	Siemens	5SH4163	=100/5.7 5SH4163
=100-0F02	2	NEOZED Locking spring 2 - 16 A	D02	Lindner	1713.	=100/5.7 1713.
=100-0P2	1	Voltmeter 500v		Langer Messtechnik GmbH	M10006617	=100/5.7 RQ 72 E 500V
=100-0S00	1	Mushroom push button red,	1NO+1NC, locking, with rotatory unlocking	Siemens	M10015479	=100/6.6 3SB32 01-1HA20-0CC0
=100-0S00	2	Switching element w.1 switch member 1no		Siemens	M10017540	=100/6.6 3SB34 03-0B
=100-0S00	1	Protecting cap	for Pilz-Push button	Siemens	3SB19 02-2BH	=100/6.6 3SB19 02-2BH
=100-0S00	1	Tag holder	for EMERGENCY-OFF Pilz-Push button	Moeller	M22-XAK1	=100/6.6 M22-XAK1
=100+S-XSBT1	1	Socket insert 10-pol +PE	16A max, 500V	ILME GmbH	2302895	=100/6.7 CSEF 10
=100+S-XSBT1	1	Add-on housing	with 2 Bow	ILME GmbH	2332565	=100/6.7 CHI 10
=100+S-XSBT2	1	Plug housing M20 red		ILME GmbH	2332604	=100/6.7 MHOR 10.20
=100+S-XSBT2	1	Pin insert 10-pol +PE	16A max, 500V	ILME GmbH	2302911	=100/6.7 CSEM 10
=100+S-XSBT2.	1	Plug housing M20	with Bolt for 2 Bow	ILME GmbH	2302913	=100/6.7 MHO 10.20
=100+S-XSBT2.	1	Pin insert 10-pol +PE	16A max, 500V	ILME GmbH	2302911	=100/6.7 CSEM 10
=100-D1	1	Switchgear 24 v	3NO+1NC	Pilz GmbH & Co.	M10015065	=100/6.1.4 PNOZ X4
=100-0F2	1	NEOZED FUSE BASE, 1-POL,	D01, 16A, E14,W.INSULATING COVER	Lindner	2724.	=100/7.1 2724.
=100-0F2	1	NEOZED Screw cap Plastic	D01,16A, E14,W.TEST HOLE	Siemens	5SH4116	=100/7.1 5SH4116
=100-0F2	1	FUSE LINK D01, 6A NEOZED	400VAC/250VDC, gL-gG	Lindner	M10004051	=100/7.1 1700.006
=100-0F2	1	SLEEVE-TYPE GAUGE RING OF THE FUSE NEOZED 6A	Base d01	Lindner	M10021288	=100/7.1 1705.006
=100-KN1	1	Auxiliary relay sirius	2NO+2NC 24VDC, Cage Clamp	Siemens	2256202	=100/7.1 3RH2122-2BB40
=100-KN2	1	Auxiliary relay sirius	2NO+2NC 24VDC, Cage Clamp	Siemens	2256202	=100/7.2 3RH2122-2BB40
=100-0F3	1	Fuse link size 10 x 38	16A, 660V, gR	Woechner GmbH & Co. KG	M10019069	=100/7.3 31 211
=100-0F3	1	Auxiliary switch 1no 1nc	for ls-switch d=70mm	Siemens	M10019130	=100/7.3 5ST3 010
=100-0S1	1	Key-operated switch, o-i ronis	1NO w.holder	Siemens	M10021350	=100/7.3 3SB32 02-4AD11-0CC0
=100-0S1	1	Tag holder		Siemens	3SB39 25-0AV	=100/7.3 3SB39 25-0AV
=100-0K1	1	Contacteur, 4kw/400V	3H 1S 24V DC, Cage-Clamp	Siemens	2256186	=100/7.3 3RT2016-2BB41

9

DATE		04.Dez.2015		KLEEMANN GMBH		PART'S LIST		KLEEMANN SERIES		K007		= STK		+	
EDITED		JBR		MOBICAT MC 120 Z EU				KLEEMANN MATERIAL NO		2315434		CAE-SYSTEM: EPLAN 5.70		PG. 8	
CONTR.		D. MALLKOWSKY		ORIGIN		REP.F.		REP.T.				PG.		13	

7

# Part's list

TPLSTK05 12.10.2015

Component designation	Amount	DESIGNATION	Manufacturer	Article number	Page/Path	Model number
=100-0K1	1	Auxiliary switch block 2NO+2NC Cage-Clamp-Connection	Siemens	2255490	=100/7.3	3RH2911-2FA22
=100-GF2	1	NEOZED FUSE BASE, 1-POL, D01, 16A, E14,W.INSULATING COVER	Lindner	2724.	=100/7.5	2724.
=100-GF2	1	NEOZED Screw cap Plastic D01,16A, E14,W.TEST HOLE	Siemens	5SH4116	=100/7.5	5SH4116
=100-GF2	1	FUSE LINK D01, 10A NEOZED 400VAC/250VDC, gL-gG	Lindner	M10004052	=100/7.5	1700.01
=100-GF2	1	SLEEVE-TYPE GAUGE RING OF THE FUSE NEOZED 10A Base d01	Lindner	M10021289	=100/7.5	1705.01
=100-0F4	1	NEOZED FUSE BASE, 1-POL, D01, 16A, E14,W.INSULATING COVER	Lindner	2724.	=100/7.6	2724.
=100-0F4	1	NEOZED Screw cap Plastic D01,16A, E14,W.TEST HOLE	Siemens	5SH4116	=100/7.6	5SH4116
=100-0F4	1	FUSE LINK D01, 2A NEOZED 400VAC/250VDC, gL-gG	Lindner	M10006604	=100/7.6	1700.002
=100-0F4	1	SLEEVE-TYPE GAUGE RING OF THE FUSE NEOZED 2A Base d01	Lindner	M10021286	=100/7.6	1705.002
=100-0F4	1	NEOZED Locking spring 2 - 16 A D02	Lindner	1713.	=100/7.6	1713.
=100+M-00H2	1	Siren 24v dc, 0,5a	Funke+Huster GmbH	M10011815	=100/7.6	KS 24
=100+M-00H3	1	Flash light AC/DC 24V	Telemecanique	M10011814	=100/7.8	XVB L6B5AB
=100-1T1	1	Current transformer ac 32 500/5A	Langer Messtechnik GmbH	M00000009	=100/8.1	TAC 32 500/5A
=100-1T2	1	Current transformer ac 32 500/5A	Langer Messtechnik GmbH	M00000009	=100/8.1	TAC 32 500/5A
=100-1T3	1	Current transformer ac 32 500/5A	Langer Messtechnik GmbH	M00000009	=100/8.1	TAC 32 500/5A
=100-1P1	1	Ammeter 500/1000/5a	Langer Messtechnik GmbH	M10011872	=100/8.2	RQ 72 E 500/1000/5A
=100-1K01	1	Monitoring relay 1 changeover cont.,24-240V AC/DC,0,1-10A AC/DC	Siemens	M10014275	=100/8.3	3UG46 22-2AW30
=100-1F1	1	Monitoring relay 1,6-16A, 1W, 24-240V AC/DC	Siemens	2374312	=100/8.3	3RR2241-2FW30
=100-1F1	1	Bearer for Stand-alone installation f. 3RU21/3RB30/3RB31 Gr. S00	Siemens	2374313	=100/8.3	3RU2916-3AC01
=100-1KC1	1	Motor contactor, 90kw/400v 3MC,2NO+2NC,220-240V AC/DC,w.Varistor	Siemens	3RT10 56-2AP36	=100/9.1	3RT10 56-2AP36
=100-1KT1	1	Time-delay relay 24v dc/ac,200...240v ac 1NO+1NO delayed, Cage Clamp	Siemens	M10013725	=100/9.3	3RP15 76-2NP30
=100-1KC2	1	Motor contactor, 90kw/400v 3MC,2NO+2NC,220-240V AC/DC,w.Varistor	Siemens	3RT10 56-2AP36	=100/9.4	3RT10 56-2AP36
=100-1KC3	1	Motor contactor, 75kw/400v 3MC,2NO+2NC,220-240V AC/DC,w.Varistor	Siemens	3RT10 55-2AP36	=100/9.6	3RT10 55-2AP36
=100-2Q1	1	Circuit breaker 4,5-6,3a with auxiliary switch,for motor protecting	Siemens	2255703	=100/10.1	3RV2011-1GA15
=100-2Q1	1	OM Adaptor 25A,690V, UL 508	Rittal GmbH & Co. KG	SV 9340.310	=100/10.1	SV 9340.310
=100-2Q1	1	Mounting rail 45mm	Rittal GmbH & Co. KG	2196728	=100/10.1	SV 9342.850
=100-2F1	1	FUSE ELEMENT SV Typ d 02-e 18	Rittal GmbH & Co. KG	M10011818	=100/10.4	SV 3418.000
=100-2F1	1	Side covering	Rittal GmbH & Co. KG	M00000008	=100/10.4	SV 3093.000
=100-2F1	3	SLEEVE-TYPE GAUGE RING OF THE FUSE NEOZED 25A Base d02	Lindner	M10021296	=100/10.4	1706.025
=100-2F1	3	FUSE LINK 25A NEOZED D02, 400VAC/250VDC, GL-GG	Lindner	M10006606	=100/10.4	1701.025
=100-2F1	3	NEOZED Screw cap Plastic D02, 63A, E18,W.TEST HOLE	Siemens	5SH4163	=100/10.4	5SH4163
=100-2F1	3	NEOZED Locking spring 2 - 16 A D02	Lindner	1713.	=100/10.4	1713.
=100-3Q1	1	Circuit breaker 11-16a with auxiliary switch,for motor protecting	Siemens	2255713	=100/10.7	3RV2011-4AA15
=100-3Q1	1	OM Adaptor 25A,690V, UL 508	Rittal GmbH & Co. KG	SV 9340.310	=100/10.7	SV 9340.310
=100-3Q1	1	Mounting rail 45mm	Rittal GmbH & Co. KG	2196728	=100/10.7	SV 9342.850
=100-3X1	1	Assembly socket 3-pol +N+PE 16A, 415V	Hilpress GmbH	56022	=100/10.7	56022
=100-4Q1	1	Power switch 27-32A with auxiliary switch,for motor protecting	Siemens	3RV2021-4EA15	=100/11.1	3RV2021-4EA15
=100-4Q1	1	OM Adaptor 32A,690V	Rittal GmbH & Co. KG	2196715	=100/11.1	SV 9340.460
=100-4Q1	1	Mounting rail 45mm	Rittal GmbH & Co. KG	2196728	=100/11.1	SV 9342.850
=100-4F1	1	Monitoring relay 4-40A, 1W, 24-240V AC/DC	Siemens	2305008	=100/11.2	3RR2242-2FW30
=100-4F1	1	Bearer for Stand-alone installation f. 3RU21/3RB30/3RB31 Gr. S0	Siemens	2305012	=100/11.2	3RU2926-3AC01
=100-5Q1	1	Circuit breaker 7-10a with auxiliary switch,for motor protecting	Siemens	2255708	=100/11.4	3RV2011-1JA15
=100-5Q1	1	OM Adaptor 25A,690V, UL 508	Rittal GmbH & Co. KG	SV 9340.310	=100/11.4	SV 9340.310
=100-5Q1	1	Mounting rail 45mm	Rittal GmbH & Co. KG	2196728	=100/11.4	SV 9342.850
=100-5F1	1	Monitoring relay 1,6-16A, 1W, 24-240V AC/DC	Siemens	2374312	=100/11.5	3RR2241-2FW30
=100-5F1	1	Bearer for Stand-alone installation f. 3RU21/3RB30/3RB31 Gr. S00	Siemens	2374313	=100/11.5	3RU2916-3AC01
=100-5Q2	1	Circuit breaker 7-10a with auxiliary switch,for motor protecting	Siemens	2255708	=100/11.7	3RV2011-1JA15
=100-5Q2	1	OM Adaptor 25A,690V, UL 508	Rittal GmbH & Co. KG	SV 9340.310	=100/11.7	SV 9340.310
=100-5Q2	1	Mounting rail 45mm	Rittal GmbH & Co. KG	2196728	=100/11.7	SV 9342.850
=100-5F2	1	Monitoring relay 1,6-16A, 1W, 24-240V AC/DC	Siemens	2374312	=100/11.7	3RR2241-2FW30

DATE		04.Dez.2015		KLEEMANN GMBH		 		PART'S LIST		KLEEMANN SERIES		K007		= STK		+	
EDITED		JBR		MOBICAT MC 120 Z EU						KLEEMANN MATERIAL NO		2315434		CAE-SYSTEM: EPLAN 5.70		PG. 9	
CONTR.		D. MALLKOWSKY														PG. 13	
MODIFICAT.	DATE	NAME	NORM	DIN	ORIGIN	REP.F.	REP.T.										



# Part's list

TPLSTK05 12.10.2015

Component designation	Amount	DESIGNATION	Manufacturer	Article number	Page/Path	Model number
=100-5F2	1	Bearer for Stand-alone installation	f. 3RU21/3RB30/3RB31 Gr. S00	Siemens	2374313	=100/11.7 3RU2916-3AC01
=100-6Q1	1	Circuit breaker 11-16a	with auxiliary switch,for motor protecting	Siemens	2255713	=100/12.1 3RV2011-4AA15
=100-6Q1	1	OM Adaptor	25A,690V, UL 508	Rittal GmbH & Co. KG	SV 9340.310	=100/12.1 SV 9340.310
=100-6Q1	1	Mounting rail 45mm		Rittal GmbH & Co. KG	2196728	=100/12.1 SV 9342.850
=100-7F1	1	FUSE ELEMENT SV	Typ d 02-e 18	Rittal GmbH & Co. KG	M10011818	=100/12.4 SV 3418.000
=100-7F1	1	Side covering		Rittal GmbH & Co. KG	M00000008	=100/12.4 SV 3093.000
=100-7F1	3	Fuse link 63a	D02, 400VAC/250VDC, GL-GG	Lindner	M10009493	=100/12.4 1701.063
=100-7F1	3	NEOZED Screw cap Plastic	D02, 63A, E18,W.TEST HOLE	Siemens	5SH4163	=100/12.4 5SH4163
=100-7F1	3	NEOZED Locking spring 2 - 16 A	D02	Lindner	1713.	=100/12.4 1713.
=100-7F2	1	Monitoring relay 4-40A,	1W, 24-240V AC/DC	Siemens	2305008	=100/12.4 3RR2242-2FW30
=100-7F2	1	Bearer for Stand-alone installation	f. 3RU21/3RB30/3RB31 Gr. S0	Siemens	2305012	=100/12.4 3RU2926-3AC01
=100-9Q1	1	Circuit breaker 7-10a	with auxiliary switch,for motor protecting	Siemens	2255708	=100/13.1 3RV2011-1JA15
=100-9Q1	1	OM Adaptor	25A,690V, UL 508	Rittal GmbH & Co. KG	SV 9340.310	=100/13.1 SV 9340.310
=100-9Q1	1	Mounting rail 45mm		Rittal GmbH & Co. KG	2196728	=100/13.1 SV 9342.850
=100-10Q1	1	Circuit breaker 4,5-6,3a	with auxiliary switch,for motor protecting	Siemens	2255703	=100/13.4 3RV2011-1GA15
=100-10Q1	1	OM Adaptor	32A,690V, UL 508	Rittal GmbH & Co. KG	M10025431	=100/13.4 SV 9340.510
=100-10Q1	1	Mounting rail 45mm		Rittal GmbH & Co. KG	2196728	=100/13.4 SV 9342.850
=100-13Q1	1	Circuit breaker 0,28-0,4a	with auxiliary switch,for motor protecting	Siemens	2255735	=100/13.7 3RV2011-0EA15
=100-13Q1	1	OM Adaptor	25A,690V, UL 508	Rittal GmbH & Co. KG	SV 9340.310	=100/13.7 SV 9340.310
=100-8Q1	1	Control switch 4-pol	12kw 400V 32A	Moeller	M10013874	=100/14.1 T3-4-8223/E
=100-8A1	1	Frequency converter	380-480V, 25/29A, 50-60Hz, 11/15kw	Control Techniques	M20000268	=100/14.2 SK 2403
=100-8F1	1	FUSE ELEMENT SV	Typ d 02-e 18	Rittal GmbH & Co. KG	M10011818	=100/14.2 SV 3418.000
=100-8F1	1	Side covering		Rittal GmbH & Co. KG	M00000008	=100/14.2 SV 3093.000
=100-8F1	3	SLEEVE-TYPE GAUGE RING OF THE FUSE NEOZED 35A	Base d02	Lindner	M10021297	=100/14.2 1706.035
=100-8F1	3	FUSE LINK 35A NEOZED	D02, 400VAC/250VDC, GL-GG	Lindner	M10006607	=100/14.2 1701.035
=100-8F1	3	NEOZED Screw cap Plastic	D02, 63A, E18,W.TEST HOLE	Siemens	5SH4163	=100/14.2 5SH4163
=100-8F1	3	NEOZED Locking spring 2 - 16 A	D02	Lindner	1713.	=100/14.2 1713.
=100-8L1	1	Line reactor	28,8A, max.600V 50-60Hz	Control Techniques	KDD 0,4/N/600V/28,8A/4UK	=100/14.2 KDD 0,4/N/600V/28,8A/4UK
=100-8F2	1	Overload relay 7-10a, 1no+1nc	f.individual assembly	Siemens	2255404	=100/14.2 3RU2116-1JC1
=100-8F3	1	Overload relay 7-10a, 1no+1nc	f.individual assembly	Siemens	2255404	=100/14.4 3RU2116-1JC1
=100-8RB	1	Frame resistance SP	100W 400V 37,5 Ohm	Control Techniques	M10020877	=100/14.7 SP
=100-SC	1	Handle 2 switch positions,	locking, black, 1no	Siemens	M10021302	=100/17.1 3SB32 02-2KA11-0CC0
=100-SC	1	Tag holder		Siemens	3SB39 25-0AV	=100/17.1 3SB39 25-0AV
=100-SC	1	IVS-TOP HAT RAIL ADAPTOR		Klöckner Moeller	M10018771	=100/17.1 M22-IVS
=100-A0_OP	1	Operator panel	256kB user memory, 24V DC	VIPA GmbH	M10019119	=100/17.2 OP 03 603-10P00
=100-A_FW	1	Remote maintenance system		MB Connect Line	M20000333	=100/17.2 MDH 513
=100-A_FW	1	Connecting cable		MB Connect Line	8248	=100/17.2 8248
=100-A_FW	1	MPI Connecting cable 1,2m		MB Connect Line	KS 1.2/9	=100/17.2 KS 1.2/9
=100-A0_CPU	1	PLC-CPU WITH MPI	256 Counter, 96kbyte RAM	VIPA GmbH	2302910	=100/17.2 VIPA 214-1BA03
=100-A0_CPU	1	Bus connector 4-fold		VIPA GmbH	290-0AA40	=100/17.2 290-0AA40
=100-A0_CPU	1	Bus connector 8-fold		VIPA GmbH	290-0AA80	=100/17.2 290-0AA80
=100-A0_2	1	In-/output module sm 238	12DI+4DIO,3AI+1Pt100,2AO,24V DC	VIPA GmbH	M10020887	=100/17.2 SM 238-2BC00
=100-A0_3	1	Digital output module sm 222	16DO, 24V DC, 1A	VIPA GmbH	M10021058	=100/17.4 SM 222-1BH10
=100-A0_4	1	Digital input module sm 221	32DI, 24VDC	VIPA GmbH	M10021059	=100/17.4 SM 221-2BL10
=100-A0_5	1	Digital input module sm 221	32DI, 24VDC	VIPA GmbH	M10021059	=100/17.5 SM 221-2BL10
=100-A0_6	1	Digital output module sm 222	32DO, 24V DC, 1A	VIPA GmbH	M10021060	=100/17.6 SM 222-2BL10
=100-1K1	1	Plug-in base w. relay	2 changeover contact 250V AC/8A coil 24V DC	Wago GmbH & Co. KG	M10019133 + M10019138	=100/22.1 788-312
=100-1K08	1	Contact, 3kw/400V	3H 1NC 24V DC, Cage-Clamp	Siemens	2256178	=100/22.5 3RT2015-2BB42
=100-2KC1	1	Contact, 3kw/400V	3H 1NC 24V DC, Cage-Clamp	Siemens	2256178	=100/23.1 3RT2015-2BB42
=100-2KC2	1	Contact, 3kw/400V	3H 1NC 24V DC, Cage-Clamp	Siemens	2256178	=100/23.2 3RT2015-2BB42

DATE		04.Dez.2015		KLEEMANN GMBH				PART'S LIST		KLEEMANN SERIES K007		= STK		+	
EDITED		JBR		MOBICAT MC 120 Z EU				KLEEMANN MATERIAL NO 2315434		CAE-SYSTEM: EPLAN 5.70		PG. 10		PG. 13	
MODIFICAT.	DATE	NAME	NORM	DIN	ORIGIN	REP.F.	REP.T.								

# Part's list

TPLSTK05 12.10.2015

Component designation	Amount	DESIGNATION	Manufacturer	Article number	Page/Path	Model number
=100-3KC1	1	Contacteur, 5,5kw/400V 3H 1S 24V DC, Cage-Clamp	Siemens	2256190	=100/23.3	3RT2017-2BB41
=100-2KC3	1	Contacteur, 11kw/400V 3H 1S+1NC 24V DC, Cage-Clamp	Siemens	2256200	=100/23.4	3RT2026-2BB40
=100-4KC1	1	Contacteur 15kw/400V 3H 1S+1NC, 24V DC, without Varistor,	Siemens	2268888	=100/23.5	3RT2027-2BB40
=100-5KC1	1	Contacteur, 4kw/400V 3H 1S 24V DC, Cage-Clamp	Siemens	2256186	=100/23.6	3RT2016-2BB41
=100-5KC2	1	Contacteur, 4kw/400V 3H 1S 24V DC, Cage-Clamp	Siemens	2256186	=100/23.7	3RT2016-2BB41
=100-6KC1	1	Contacteur, 5,5kw/400V 3H 1S 24V DC, Cage-Clamp	Siemens	2256190	=100/23.8	3RT2017-2BB41
=100-S0.0	1	Illuminated push button white, led integrated flat push button 1no, uc 24v	Siemens	2219470	=100/24.1	3SB32 45-0AA61-0CC0
=100-S0.0	1	Protecting cap for Push button flat	Siemens	3SB39 21-0AH	=100/24.1	3SB39 21-0AH
=100-S0.0	1	Tag holder	Siemens	3SB39 25-0AV	=100/24.1	3SB39 25-0AV
=100-S0.1	1	Push button red flat push button 1nc	Siemens	2219480	=100/24.2	3SB32 03-0AA21-0CC0
=100-S0.1	1	Protecting cap for Push button flat	Siemens	3SB39 21-0AH	=100/24.2	3SB39 21-0AH
=100-S0.1	1	Tag holder	Siemens	3SB39 25-0AV	=100/24.2	3SB39 25-0AV
=100-S0.2	1	Handle 2 switch positions, locking, black, 1no	Siemens	M10021302	=100/24.3	3SB32 02-2KA11-0CC0
=100-S0.2	1	Protecting cap for Handle	Siemens	3SB39 21-0BA	=100/24.3	3SB39 21-0BA
=100-S0.2	1	Tag holder	Siemens	3SB39 25-0AV	=100/24.3	3SB39 25-0AV
=100-S0.3	1	Push button blue flat push button, 1no	Siemens	3SB32 02-0AA51-0CC0	=100/24.4	3SB32 02-0AA51-0CC0
=100-S0.3	1	Protecting cap for Push button flat	Siemens	3SB39 21-0AH	=100/24.4	3SB39 21-0AH
=100-S0.3	1	Tag holder	Siemens	3SB39 25-0AV	=100/24.4	3SB39 25-0AV
=100-S0.4	1	Illuminated push button red, led integrated flat push button 1nc, uc 24v	Siemens	2219472	=100/24.5	3SB32 46-0AA21-0CC0
=100-S0.4	2	Switching element w.1 switch member 1no	Siemens	M10017540	=100/24.5	3SB34 03-0B
=100-S0.4	1	Protecting cap for Push button flat	Siemens	3SB39 21-0AH	=100/24.5	3SB39 21-0AH
=100-S0.4	1	Tag holder	Siemens	3SB39 25-0AV	=100/24.5	3SB39 25-0AV
=100-2S2	1	Handle 3 switch positions, black, 1nc, 1nc	Siemens	3SB32 10-2DA11-0CC0	=100/24.6	3SB32 10-2DA11-0CC0
=100-2S2	1	Switching element 1nc Mounting depth 50mm	Siemens	M10017539	=100/24.6	3SB34 03-0C
=100-2S2	1	Protecting cap for Handle	Siemens	3SB39 21-0BA	=100/24.6	3SB39 21-0BA
=100-2S2	1	Tag holder	Siemens	3SB39 25-0AV	=100/24.6	3SB39 25-0AV
=100-2S1	1	Illuminated push button green, led integrated flat push button 1no, uc 24v	Siemens	M10020706	=100/24.7	3SB32 45-0AA41-0CC0
=100-2S1	1	Protecting cap for Push button flat	Siemens	3SB39 21-0AH	=100/24.7	3SB39 21-0AH
=100-2S1	1	Tag holder	Siemens	3SB39 25-0AV	=100/24.7	3SB39 25-0AV
=100-3S1	1	Illuminated push button green, led integrated flat push button 1no, uc 24v	Siemens	M10020706	=100/24.8	3SB32 45-0AA41-0CC0
=100-3S1	1	Protecting cap for Push button flat	Siemens	3SB39 21-0AH	=100/24.8	3SB39 21-0AH
=100-3S1	1	Tag holder	Siemens	3SB39 25-0AV	=100/24.8	3SB39 25-0AV
=100-4S1	1	Illuminated push button green, led integrated flat push button 1no, uc 24v	Siemens	M10020706	=100/25.1	3SB32 45-0AA41-0CC0
=100-4S1	1	Protecting cap for Push button flat	Siemens	3SB39 21-0AH	=100/25.1	3SB39 21-0AH
=100-4S1	1	Tag holder	Siemens	3SB39 25-0AV	=100/25.1	3SB39 25-0AV
=100-5S1	1	Illuminated push button green, led integrated flat push button 1no, uc 24v	Siemens	M10020706	=100/25.2	3SB32 45-0AA41-0CC0
=100-5S1	1	Protecting cap for Push button flat	Siemens	3SB39 21-0AH	=100/25.2	3SB39 21-0AH
=100-5S1	1	Tag holder	Siemens	3SB39 25-0AV	=100/25.2	3SB39 25-0AV
=100-6S1	1	Illuminated push button green, led integrated flat push button 1no, uc 24v	Siemens	M10020706	=100/25.3	3SB32 45-0AA41-0CC0
=100-6S1	1	Protecting cap for Push button flat	Siemens	3SB39 21-0AH	=100/25.3	3SB39 21-0AH
=100-6S1	1	Tag holder	Siemens	3SB39 25-0AV	=100/25.3	3SB39 25-0AV
=100-7S1	1	Illuminated push button green, led integrated flat push button 1no, uc 24v	Siemens	M10020706	=100/25.4	3SB32 45-0AA41-0CC0
=100-7S1	1	Protecting cap for Push button flat	Siemens	3SB39 21-0AH	=100/25.4	3SB39 21-0AH
=100-7S1	1	Tag holder	Siemens	3SB39 25-0AV	=100/25.4	3SB39 25-0AV
=100-8S1	1	Illuminated push button green, led integrated flat push button 1no, uc 24v	Siemens	M10020706	=100/25.5	3SB32 45-0AA41-0CC0
=100-8S1	1	Protecting cap for Push button flat	Siemens	3SB39 21-0AH	=100/25.5	3SB39 21-0AH
=100-8S1	1	Tag holder	Siemens	3SB39 25-0AV	=100/25.5	3SB39 25-0AV
=100-10S1	1	Illuminated push button green, led integrated flat push button 1no, uc 24v	Siemens	M10020706	=100/25.7	3SB32 45-0AA41-0CC0
=100-10S1	1	Protecting cap for Push button flat	Siemens	3SB39 21-0AH	=100/25.7	3SB39 21-0AH
=100-10S1	1	Tag holder	Siemens	3SB39 25-0AV	=100/25.7	3SB39 25-0AV

DATE		04.Dez.2015		KLEEMANN GMBH		 		PART'S LIST		KLEEMANN SERIES		K007		= STK		+	
EDITED		JBR		MOBICAT MC 120 Z EU						KLEEMANN MATERIAL NO		2315434		CAE-SYSTEM: EPLAN 5.70		PG. 11	
CONTR.		D. MALLKOWSKY														PG. 13	
MODIFICAT.	DATE	NAME	NORM	DIN	ORIGIN	REP.F.	REP.T.										

# Part's list

TPLSTK05 12.10.2015

Component designation	Amount	DESIGNATION	Manufacturer	Article number	Page/Path	Model number
=100-9S1	1	Illuminated push button green, led integrated	Siemens	M10020706	=100/26.4	3SB32 45-0AA41-0CC0
=100-9S1	1	Protecting cap	Siemens	3SB39 21-0AH	=100/26.4	3SB39 21-0AH
=100-9S1	1	Tag holder	Siemens	3SB39 25-0AV	=100/26.4	3SB39 25-0AV
=100-S5.2	1	Illuminated push button yellow,led integrated	Siemens	3SB32 45-0AA31-0CC0	=100/29.3	3SB32 45-0AA31-0CC0
=100-S5.2	1	Protecting cap	Siemens	3SB39 21-0AH	=100/29.3	3SB39 21-0AH
=100-S5.2	1	Tag holder	Siemens	3SB39 25-0AV	=100/29.3	3SB39 25-0AV
=100+8S	1	Handle 3 switch positions,	Siemens	M10021301	=100/29.7	3SB32 10-2EA11-0CC0
=100+8S	1	Protecting cap	Siemens	3SB39 21-0BA	=100/29.7	3SB39 21-0BA
=100+8S	1	Tag holder	Siemens	3SB39 25-0AV	=100/29.7	3SB39 25-0AV
=100-7KC1	1	Contactactor 15kw/400V	Siemens	2268888	=100/32.1	3RT2027-2BB40
=100-8KC1	1	Contactactor 15kw/400V	Siemens	2268888	=100/32.2	3RT2027-2BB40
=100-9KC1	1	Contactactor, 5,5kw/400V	Siemens	2256190	=100/32.3	3RT2017-2BB41
=100-10KC1	1	Contactactor, 3kw/400V	Siemens	2256180	=100/32.4	3RT2015-2BB41
=100-00K2	1	Plug-in base w. relay	Wago GmbH & Co. KG	M10019133 + M10019138	=100/32.7	788-312
=100-00K3	1	Plug-in base w. relay	Wago GmbH & Co. KG	M10019133 + M10019138	=100/32.8	788-312
=100-8K2	1	Plug-in base w. relay	Wago GmbH & Co. KG	M10019133 + M10019138	=100/33.2	788-312
=100-0H6	1	Signal lamp blue, with smooth lens	Siemens	3SB32 44-6AA50-0CC0	=100/33.8	3SB32 44-6AA50-0CC0
=100-0H6	1	Tag holder	Siemens	3SB39 25-0AV	=100/33.8	3SB39 25-0AV
=100-0H2	1	Signal lamp white, with smooth lens	Siemens	3SB32 44-6AA60-0CC0	=100/34.2	3SB32 44-6AA60-0CC0
=100-0H2	1	Tag holder	Siemens	3SB39 25-0AV	=100/34.2	3SB39 25-0AV
=100-0H2.1	1	Signal lamp white, with smooth lens	Siemens	3SB32 44-6AA60-0CC0	=100/34.3	3SB32 44-6AA60-0CC0
=100-0H2.1	1	Tag holder	Siemens	3SB39 25-0AV	=100/34.3	3SB39 25-0AV
=100-LS1	1	Handle 2 switch positions,	Siemens	M10021302	=100/36.1	3SB32 02-2KA11-0CC0
=100-LS1	1	Protecting cap	Siemens	3SB39 21-0BA	=100/36.1	3SB39 21-0BA
=100-LS1	1	Tag holder	Siemens	3SB39 25-0AV	=100/36.1	3SB39 25-0AV
=100-LS1	1	Base for relay lzx:mt32...	Siemens	M10010285	=100/36.2	LZX:MT78750
=100-GA1	1	Key-operated device	AVS Aggregatebau	M10011598	=100/37.0	K26MUE_KSE_72
=100-GF1	1	2-lead-fuse clip, gray	Wago GmbH & Co. KG	M10015067	=100/37.0	282-696
=100-GF1	1	Cover and distance plate, orange	Wago GmbH & Co. KG	M10015068	=100/37.0	282-333
=100-GK1	1	Plug-in base w. relay	Wago GmbH & Co. KG	M10019133 + M10019138	=100/37.1	788-312
=100-GK61	1	Plug-in base w. relay	Wago GmbH & Co. KG	M10019133 + M10019138	=100/37.2	788-312
=100-GK6	1	Plug-in base w. relay	Wago GmbH & Co. KG	M10019133 + M10019138	=100/37.3	788-312
=100-GK9	1	Plug-in base w. relay	Wago GmbH & Co. KG	M10019133 + M10019138	=100/37.6	788-312
=100-GK9.1	1	Plug-in base w. relay	Wago GmbH & Co. KG	M10019133 + M10019138	=100/37.7	788-312
=100-GK26	1	Plug-in base w. relay	Wago GmbH & Co. KG	M10019133 + M10019138	=100/38.2	788-312
=100-GKT1	1	Time-delay relay with led	Siemens	M10014285	=100/38.3	3RP15 25-2AP30
=100-GP1	1	Oil-pressure indicator electrical, round	Motometer	M10014439	=100/40.1	644 060 1026
=100-GP2	1	Temperature indicator, round	Motometer	M10014440	=100/40.2	641 012 1060
=100-GP3	1	Fuel level electric, round d=64 mm	Motometer	M10019161	=100/40.4	609 060 1039
=100-GKT2	1	Time-delay relay with led	Siemens	M10014285	=100/40.6	3RP15 25-2AP30
=100-SN0	1	Handle 2 switch positions,	Siemens	M10021302	=100/41.1	3SB32 02-2KA11-0CC0
=100-SN0	2	Switching element 1nc	Siemens	M10017539	=100/41.1	3SB34 03-0C
=100-SN0	1	Protecting cap	Siemens	3SB39 21-0BA	=100/41.1	3SB39 21-0BA
=100-SN0	1	Tag holder	Siemens	3SB39 25-0AV	=100/41.1	3SB39 25-0AV
=100-KGA1	1	Auxiliary relay sirius	Siemens	2256202	=100/41.2	3RH2122-2BB40
=100-KGA2	1	Plug-in base w. relay	Wago GmbH & Co. KG	M10019133 + M10019138	=100/41.2	788-312
=100-KGA3	1	Plug-in base w. relay	Wago GmbH & Co. KG	M10019133 + M10019138	=100/41.3	788-312
=100-8K04	1	Plug-in base w. relay	Wago GmbH & Co. KG	M10019133 + M10019138	=100/41.4	788-312
=100-8K03	1	Plug-in base w. relay	Wago GmbH & Co. KG	M10019133 + M10019138	=100/41.4	788-312

DATE		04.Dez.2015		KLEEMANN GMBH		 		PART'S LIST		KLEEMANN SERIES		K007		= STK		+	
EDITED		JBR		MOBICAT MC 120 Z EU						KLEEMANN MATERIAL NO		2315434		CAE-SYSTEM: EPLAN 5.70		PG. 12	
CONTR.		D. MALLKOWSKY												PG. 13			
MODIFICAT.	DATE	NAME	NORM	DIN	ORIGIN	REP.F.	REP.T.										

# Part's list

TPLSTK05 12.10.2015

Component designation	Amount	DESIGNATION	Manufacturer	Article number	Page/Path	Model number	
=100-9S1	1	Illuminated push button green, led integrated	flat push button 1no, uc 24v	Siemens	M10020706	=100/26.4	3SB32 45-0AA41-0CC0
=100-9S1	1	Protecting cap	for Push button flat	Siemens	3SB39 21-0AH	=100/26.4	3SB39 21-0AH
=100-9S1	1	Tag holder		Siemens	3SB39 25-0AV	=100/26.4	3SB39 25-0AV
=100-S5.2	1	Illuminated push button yellow,led integrated	flat push button 1no, uc 24v	Siemens	3SB32 45-0AA31-0CC0	=100/29.3	3SB32 45-0AA31-0CC0
=100-S5.2	1	Protecting cap	for Push button flat	Siemens	3SB39 21-0AH	=100/29.3	3SB39 21-0AH
=100-S5.2	1	Tag holder		Siemens	3SB39 25-0AV	=100/29.3	3SB39 25-0AV
=100+8S	1	Handle 3 switch positions,	black, 1nc, 1nc	Siemens	M10021301	=100/29.7	3SB32 10-2EA11-0CC0
=100+8S	1	Protecting cap	for Handle	Siemens	3SB39 21-0BA	=100/29.7	3SB39 21-0BA
=100+8S	1	Tag holder		Siemens	3SB39 25-0AV	=100/29.7	3SB39 25-0AV
=100-7KC1	1	Contacto 15kw/400V	3H 1S+1NC, 24V DC, without Varistor,	Siemens	2268888	=100/32.1	3RT2027-2BB40
=100-8KC1	1	Contacto 15kw/400V	3H 1S+1NC, 24V DC, without Varistor,	Siemens	2268888	=100/32.2	3RT2027-2BB40
=100-9KC1	1	Contacto, 5,5kw/400V	3H 1S 24V DC, Cage-Clamp	Siemens	2256190	=100/32.3	3RT2017-2BB41
=100-10KC1	1	Contacto, 3kw/400V	3H 1S 24V DC, Cage-Clamp	Siemens	2256180	=100/32.4	3RT2015-2BB41
=100-00K2	1	Plug-in base w. relay	2 changeover contact 250V AC/8A coil 24V DC	Wago GmbH & Co. KG	M10019133 + M10019138	=100/32.7	788-312
=100-00K3	1	Plug-in base w. relay	2 changeover contact 250V AC/8A coil 24V DC	Wago GmbH & Co. KG	M10019133 + M10019138	=100/32.8	788-312
=100-8K2	1	Plug-in base w. relay	2 changeover contact 250V AC/8A coil 24V DC	Wago GmbH & Co. KG	M10019133 + M10019138	=100/33.2	788-312
=100-0H6	1	Signal lamp blue, with smooth lens	LED INTEGRATED, 24V	Siemens	3SB32 44-6AA50-0CC0	=100/33.8	3SB32 44-6AA50-0CC0
=100-0H6	1	Tag holder		Siemens	3SB39 25-0AV	=100/33.8	3SB39 25-0AV
=100-0H2	1	Signal lamp white, with smooth lens	LED INTEGRATED, 24V	Siemens	3SB32 44-6AA60-0CC0	=100/34.2	3SB32 44-6AA60-0CC0
=100-0H2	1	Tag holder		Siemens	3SB39 25-0AV	=100/34.2	3SB39 25-0AV
=100-0H2.1	1	Signal lamp white, with smooth lens	LED INTEGRATED, 24V	Siemens	3SB32 44-6AA60-0CC0	=100/34.3	3SB32 44-6AA60-0CC0
=100-0H2.1	1	Tag holder		Siemens	3SB39 25-0AV	=100/34.3	3SB39 25-0AV
=100-LS1	1	Handle 2 switch positions,	locking, black, 1no	Siemens	M10021302	=100/36.1	3SB32 02-2KA11-0CC0
=100-LS1	1	Protecting cap	for Handle	Siemens	3SB39 21-0BA	=100/36.1	3SB39 21-0BA
=100-LS1	1	Tag holder		Siemens	3SB39 25-0AV	=100/36.1	3SB39 25-0AV
=100-LS1	1	Base for relay lzx:mt32...		Siemens	M10010285	=100/36.2	LZX:MT78750
=100-GA1	1	Key-operated device		AVS Aggregatebau	M10011598	=100/37.0	K26MUE_KSE_72
=100-GF1	1	2-lead-fuse clip, gray	8mm wide, Cage Clamp	Wago GmbH & Co. KG	M10015067	=100/37.0	282-696
=100-GF1	1	Cover and distance plate, orange	2mm thick	Wago GmbH & Co. KG	M10015068	=100/37.0	282-333
=100-GK1	1	Plug-in base w. relay	2 changeover contact 250V AC/8A coil 24V DC	Wago GmbH & Co. KG	M10019133 + M10019138	=100/37.1	788-312
=100-GK61	1	Plug-in base w. relay	2 changeover contact 250V AC/8A coil 24V DC	Wago GmbH & Co. KG	M10019133 + M10019138	=100/37.2	788-312
=100-GK6	1	Plug-in base w. relay	2 changeover contact 250V AC/8A coil 24V DC	Wago GmbH & Co. KG	M10019133 + M10019138	=100/37.3	788-312
=100-GK9	1	Plug-in base w. relay	2 changeover contact 250V AC/8A coil 24V DC	Wago GmbH & Co. KG	M10019133 + M10019138	=100/37.6	788-312
=100-GK9.1	1	Plug-in base w. relay	2 changeover contact 250V AC/8A coil 24V DC	Wago GmbH & Co. KG	M10019133 + M10019138	=100/37.7	788-312
=100-GK26	1	Plug-in base w. relay	2 changeover contact 250V AC/8A coil 24V DC	Wago GmbH & Co. KG	M10019133 + M10019138	=100/38.2	788-312
=100-GKT1	1	Time-delay relay with led	1 changeover contact, Cage Clamp	Siemens	M10014285	=100/38.3	3RP15 25-2AP30
=100-GP1	1	Oil-pressure indicator electrical, round	0-10bar	Motometer	M10014439	=100/40.1	644 060 1026
=100-GP2	1	Temperature indicator, round	40-120°C	Motometer	M10014440	=100/40.2	641 012 1060
=100-GP3	1	Fuel level electric, round d=64 mm		Motometer	M10019161	=100/40.4	609 060 1039
=100-GKT2	1	Time-delay relay with led	1 changeover contact, Cage Clamp	Siemens	M10014285	=100/40.6	3RP15 25-2AP30
=100-SN0	1	Handle 2 switch positions,	locking, black, 1no	Siemens	M10021302	=100/41.1	3SB32 02-2KA11-0CC0
=100-SN0	2	Switching element 1nc	Mounting depth 50mm	Siemens	M10017539	=100/41.1	3SB34 03-0C
=100-SN0	1	Protecting cap	for Handle	Siemens	3SB39 21-0BA	=100/41.1	3SB39 21-0BA
=100-SN0	1	Tag holder		Siemens	3SB39 25-0AV	=100/41.1	3SB39 25-0AV
=100-KGA1	1	Auxiliary relay sirius	2NO+2NC 24VDC, Cage Clamp	Siemens	2256202	=100/41.2	3RH2122-2BB40
=100-KGA2	1	Plug-in base w. relay	2 changeover contact 250V AC/8A coil 24V DC	Wago GmbH & Co. KG	M10019133 + M10019138	=100/41.2	788-312
=100-KGA3	1	Plug-in base w. relay	2 changeover contact 250V AC/8A coil 24V DC	Wago GmbH & Co. KG	M10019133 + M10019138	=100/41.3	788-312
=100-8K04	1	Plug-in base w. relay	2 changeover contact 250V AC/8A coil 24V DC	Wago GmbH & Co. KG	M10019133 + M10019138	=100/41.4	788-312
=100-8K03	1	Plug-in base w. relay	2 changeover contact 250V AC/8A coil 24V DC	Wago GmbH & Co. KG	M10019133 + M10019138	=100/41.4	788-312

DATE		04.Dez.2015		KLEEMANN GMBH		 		PART'S LIST		KLEEMANN SERIES		K007		= STK		+	
EDITED		JBR		MOBICAT MC 120 Z EU						KLEEMANN MATERIAL NO		2315434		CAE-SYSTEM: EPLAN 5.70		PG. 13	
CONTR.		D. MALLKOWSKY														PG. 13	
MODIFICAT.	DATE	NAME	NORM	DIN	ORIGIN	REP.F.	REP.T.										