

Axial piston variable pump A4VG Series 32

Asia Pacific

RE-P 92003

Edition: 06.2018

Replaces: 04.2016

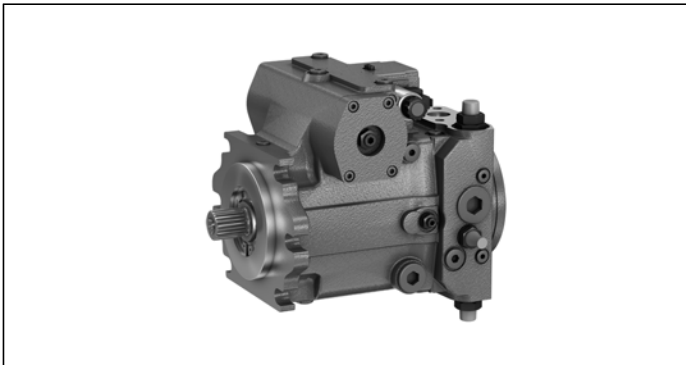

- ▶ High-pressure pump for applications in a closed circuit
- ▶ Size 28 to 180
- ▶ Nominal pressure 400 bar
- ▶ Maximum pressure 450 bar
- ▶ Closed circuit

Features

- ▶ Integrated auxiliary pump for boost and pilot oil supply
- ▶ Flow direction changes smoothly when the swashplate is moved through the neutral position
- ▶ High-pressure relief valves with integrated boost function
- ▶ With adjustable pressure cut-off as standard
- ▶ Boost-pressure relief valve
- ▶ Through drive for mounting of further pumps up to same nominal size
- ▶ Large variety of controls
- ▶ Swashplate design

Contents

Type code	2
Hydraulic fluids	5
Shaft seal	6
Working pressure range	7
Technical data	8
NV – Version without control module	11
DG – Hydraulic control, direct operated	11
HD – Proportional control, hydr., pilot-pressure related	12
HW – Proportional control, hydr., mechanical servo	14
EP – Proportional control, electric	16
EZ – Two-point control, electric	18
DA – Automatic control, speed related	19
ET – Electric control, direct operated	22
Dimensions, size 28 to 180	50
Dimensions, through drive	54
Overview of mounting options	57
Combination pumps A4VG + A4VG	58
High-pressure relief valves	59
Pressure cut-off	60
Mechanical stroke limiter	61
Stroking chamber pressure port X ₃ and X ₄	62
Filtration in the boost pump suction line	63
Filtration in the boost pump pressure line	63
External boost pressure supply	65
Dimensions with filter fitted	66
Swivel angle sensor	67
Connector for solenoids	68
Rotary inch valve	69
Installation dimensions for coupling assembly	70
Installation instructions	71
Project planning notes	74
Safety instructions	75

Type code

01	02	03	04	05	06	07	08	09	10	11	12	13	14	15	16	17	18	19	20	21	22	
A4V	G			D					/	32		-	N									

Axial piston unit

01	Swashplate design, variable, nominal pressure 400 bar, maximum pressure 450 bar	A4V
----	---	-----

Operating mode

02	Pump, closed circuit	G
----	----------------------	---

Size (NG)

03	Geometric displacement, see "Technical data" on page 8	28	40	56	71	90	125	180
----	--	----	----	----	----	----	-----	-----

Control device

		28	40	56	71	90	125	180		
04	Without control module	●	●	●	●	●	●	●	NV	
	Proportional control, hydraulic	Pilot-pressure related $p = 6$ to 18 bar	●	●	●	●	●	●	●	HD3
		Mechanical servo	●	●	●	●	●	●	●	HW
	Proportional control, electric	$U = 12$ V	●	●	●	●	●	●	●	EP3
		$U = 24$ V	●	●	●	●	●	●	●	EP4
	Two-point control, electric	$U = 12$ V	●	●	●	●	●	●	●	EZ1
		$U = 24$ V	●	●	●	●	●	●	●	EZ2
	Automatic control, speed related	$U = 12$ V	●	●	●	●	●	●	●	DA1
		$U = 24$ V	●	●	●	●	●	●	●	DA2
	Hydraulic control, direct operated		●	●	●	●	●	●	●	DG
Electric control, direct operated, two pressure reducing valves	$U = 12$ V	●	●	●	●	-	-	-	ET5	
	$U = 24$ V	●	●	●	●	-	-	-	ET6	

Pressure cut-off

05	Pressure cut-off (standard)	D
----	-----------------------------	---

Neutral position switch

06	Without neutral position switch (without code)	●	
	Neutral position switch (for HW control only)	●	L

Mechanical stroke limiter

07	Without mechanical stroke limiter (without code)	●	
	Mechanical stroke limiter, externally adjustable	●	M

Stroking chamber pressure port

08	Without stroking chamber pressure port X_3, X_4 (without code)	●	
	Stroking chamber pressure port X_3, X_4	●	T

DA control valve

		NV	HD	HW	DG	DA	EP	EZ		
09	Without DA control valve	●	●	●	●	-	●	●	1	
	DA control valve, fixed setting	-	●	●	●	●	●	-	2	
	DA control valve, mechanically adjustable with position lever	direction of actuation, clockwise	-	●	●	●	●	●	-	3R
		direction of actuation, counter-clockwise	-	●	●	●	●	●	-	3L
	DA control valve, fixed setting, ports for pilot control device	-	●	●	-	●	●	-	7	
	DA control valve, fixed setting and brake inch valve mounted, control with brake fluid	-	-	-	-	●	-	-	8	

● = Available ○ = On request - = Not available = Preferred program

01	02	03	04	05	06	07	08	09	10	11	12	13	14	15	16	17	18	19	20	21	22	
A4V	G			D					/	32		-	N									

Series

10	Series 3, index 2	32
----	-------------------	-----------

Direction of rotation

11	Viewed on drive shaft	clockwise	R
		counter-clockwise	L

Sealing material

12	NBR (nitrile rubber), shaft seal in FKM (fluoroelastomer)	N
----	---	----------

Drive shaft

			28	40	56	71	90	125	180	
13	Splined shaft DIN 5480	for single pump	●	●	●	●	●	●	●	Z
		for combination pump – 1st pump	- ¹⁾	●	●	●	●	●	- ²⁾	A
	Splined shaft ANSI B92.1a	for single pump	●	●	●	●	●	●	●	S
		for combination pump – 1st pump	- ²⁾	- ²⁾	●	●	- ²⁾	●	●	T
		only for combination pump – 2nd pump	-	●	-	-	●	-	-	U

Mounting flange

			28	40	56	71	90	125	180	
14	SAE J744	2-hole	●	●	●	-	-	-	-	C
		4-hole	-	-	-	-	-	-	●	D
		2+4-hole	-	-	-	●	●	●	-	F

Working port

			28	40	56	71	90	125	180		
15	SAE working port A and B , top and bottom	Suction port S bottom	-	●	●	●	●	●	●	02	
		Suction port S top	-	●	●	○	○	○	○	03	
	SAE working port A and B , same side right ³⁾	Suction port S bottom	●	-	-	-	-	-	-	-	10
		Suction port S top	-	-	-	●	○	●	-	-	
	SAE working port A and B , same side left ³⁾	Suction port S bottom	-	-	-	○	○	○	-	-	13
		Suction port S top	●	-	●	-	-	-	-	-	

Boost pump

16	Without integrated boost pump	without through drive	N
		with through drive	K
	Integrated boost pump	with and without through drive	F

Through drive

			28	40	56	71	90	125	180	
17	Without through drive, versions N and F (no. 16) only		●	●	●	●	●	●	●	00
	Flange SAE J744 ⁴⁾	Hub for splined shaft	●	●	●	●	●	●	●	01
		82-2 (A)	5/8 in 9T 16/32DP ⁵⁾	●	●	●	●	●	●	02
	101-2 (B)	7/8 in 13T 16/32DP ⁵⁾	●	●	●	●	●	●	●	04
		1 in 15T 16/32DP ⁵⁾	-	●	-	-	-	-	-	09
	127-2 (C) ⁶⁾	1 in 15T 16/32DP ⁵⁾	-	-	●	●	●	●	●	07
		1 1/4 in 14T 12/24DP ⁵⁾	-	-	-	-	●	-	-	73
	152-2/4 (D)	W35 2×16×9 g ⁷⁾	-	-	-	-	-	●	-	69
		1 3/4 in 13T 8/16DP ⁵⁾	-	-	-	-	-	-	●	72
	165-4 (E)	1 3/4 in 13T 8/16DP ⁵⁾	-	-	-	-	-	-	-	72

● = Available ○ = On request - = Not available

= Preferred program

1) Standard for combination pump – 1st pump: Shaft Z
 2) Standard for combination pump – 1st pump: Shaft S
 3) Only possible without attachment filter
 4) 2 = 2-hole; 4 = 4-hole

5) Hub for splined shaft to ANSI B92.1a
 6) NG90 to 180 with additional 4-hole-flange (127-4)
 7) Hub for splined shaft according to DIN 5480.

4 **A4VG Series 32** | Axial piston variable pump
Type code

01	02	03	04	05	06	07	08	09	10	11	12	13	14	15	16	17	18	19	20	21	22	
A4V	G			D					/	32		-	N									
High-pressure relief valve										Setting range Δp		28	40	56	71	90	125	180				
18	High pressure relief valve, pilot operated		100 to 420 bar		with bypass		-	-	-	●	●	●	●	●	●	●	●	●	●	●	1	
	High-pressure relief valve, direct operated, fixed setting		250 to 420 bar		without bypass		●	●	●	-	-	-	-	-	-	-	-	-	-	-	3	
					with bypass		●	●	●	-	-	-	-	-	-	-	-	-	-	-	-	5
			100 to 250 bar		without bypass		●	●	●	-	-	-	-	-	-	-	-	-	-	-	-	4
					with bypass		●	●	●	-	-	-	-	-	-	-	-	-	-	-	-	-
Filtration boost circuit/external boost pressure supply										28	40	56	71	90	125	180						
19	Filtration in the boost pump suction line						●	●	●	●	●	●	●	●	●	●	●	●	●	●	S	
	Filtration in the boost pump pressure line						●	●	●	●	●	●	●	●	●	●	●	●	●	●	D	
	Ports for external boost circuit filtration (F_e and F_a)						●	●	●	●	●	●	●	●	●	●	●	●	●	●	D	
	Attachment filter with cold start valve						-	●	●	●	●	●	●	●	●	●	●	●	●	●	●	F
	Attachment filter with cold start valve and visual contamination indicator						-	●	●	●	●	●	●	●	●	●	●	●	●	●	●	P
	Attachment filter with cold start valve and electric contamination indicator						-	●	●	●	●	●	●	●	●	●	●	●	●	●	●	B
	External boost pressure supply (version without integrated boost pump - N00, K...)						●	●	●	●	●	●	●	●	●	●	●	●	●	●	●	E
Swivel angle sensor										28 to 180												
20	Without swivel angle sensor (without code)																					
	Electric swivel angle sensor ⁸⁾																					R
Connector for solenoids⁹⁾										28 to 180												
21	Without connector (without code), only for purely hydraulic control																					
	DEUTSCH molded connector, 2-pin		without suppressor diode																			P
					with suppressor diode (only for EZ and DA)																	
Standard / special version																						
22	Standard version		without code																			
			combined with attachment part or attachment pump																			-K
	Special version																					-S
			combined with attachment part or attachment pump																			

● = Available ○ = On request - = Not available

 = Preferred program

Notice

- ▶ Note the project planning notes on page 74.
- ▶ In addition to the type code, please specify the relevant technical data when placing your order.

- 8) Please contact us if the swivel angle sensor is used for control
9) Connectors for other electric components may deviate

Hydraulic fluids

The A4VG variable pump is designed for operation with HLP mineral oil according to DIN 51524.

Application instructions and requirements for hydraulic fluids should be taken from the following data sheets before the start of project planning:

- ▶ 90220: Hydraulic fluids based on mineral oils and related hydrocarbons
- ▶ 90221: Environmentally acceptable hydraulic fluids
- ▶ 90222: Fire-resistant, water-free hydraulic fluids (HFDR/HFDU)
- ▶ 90225: Axial piston units for operation with water-free and water-containing fire-resistant hydraulic fluids (HFDR, HFDU, HFAE, HFAS, HFB, HFC).

Notes on selection of hydraulic fluid

The hydraulic fluid should be selected such that the operating viscosity in the operating temperature range is within the optimum range (v_{opt} see selection diagram).

Notice

At no point of the component may the temperature be higher than 115 °C. The temperature difference specified in the table is to be taken into account when determining the viscosity in the bearing.

Please contact us if the above conditions cannot be met due to extreme operating parameters.

Viscosity and temperature of hydraulic fluids

	Viscosity	Temperature	Comment
Cold start	$v_{max} \leq 1600 \text{ mm}^2/\text{s}$	$\theta_{st} \geq -40 \text{ }^\circ\text{C}$	$t \leq 3 \text{ min}$, $n \leq 1000 \text{ min}^{-1}$, without load $p \leq 50 \text{ bar}$
	Permissible temperature difference	$\Delta T \leq 25 \text{ K}$	between axial piston unit and hydraulic fluid in the system
Warm-up phase	$v = 1600 \text{ to } 400 \text{ mm}^2/\text{s}$	$\theta = -40 \text{ }^\circ\text{C to } -25 \text{ }^\circ\text{C}$	at $p \leq 0.7 \times p_{nom}$, $n \leq 0.5 \times n_{nom}$ and $t \leq 15 \text{ min}$
Continuous operation	$v = 400 \text{ to } 10 \text{ mm}^2/\text{s}$	$\theta = -25 \text{ }^\circ\text{C to } +110 \text{ }^\circ\text{C}$	this corresponds, for VG 46 for example, to a temperature range of +5 °C to +85 °C (see selection diagram below)
	$v_{opt} = 36 \text{ to } 16 \text{ mm}^2/\text{s}$		measured at port T Observe the permissible temperature range of the shaft seal ($\Delta T = \text{approx. } 5 \text{ K}$ between bearing/shaft seal and port T)
Short-term operation	$v_{min} \geq 7 \text{ mm}^2/\text{s}$		$t < 3 \text{ min}$, $p < 0.3 \times p_{nom}$

▼ Selection diagram

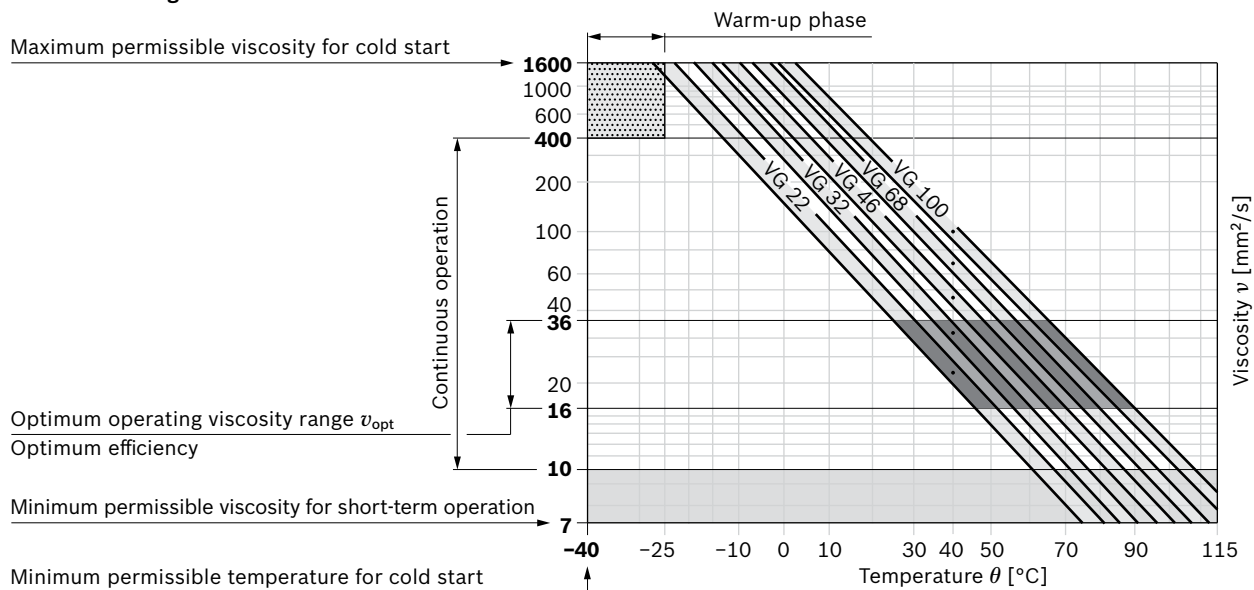

Filtration of the hydraulic fluid

Finer filtration improves the cleanliness level of the hydraulic fluid, which increases the service life of the axial piston unit. A cleanliness level of at least 20/18/15 is to be maintained according to ISO 4406.

Depending on the system and the application, for the A4VG we recommend: Filter elements $\beta_{20} \geq 100$.

At very high hydraulic fluid temperatures (90 °C to maximum 110 °C, measured at port T), a cleanliness level of at least 19/17/14 according to ISO 4406 is necessary.

Shaft seal

Permissible pressure loading

The service life of the shaft seal is influenced by the speed of the axial piston unit and the leakage pressure in the housing (case pressure). Momentary ($t < 0.1$ s) pressure peaks of up to 10 bar are allowed. The service life of the shaft seal decreases with increasing frequency of pressure peaks and increasing mean differential pressure.

The case pressure must be higher than the ambient pressure.

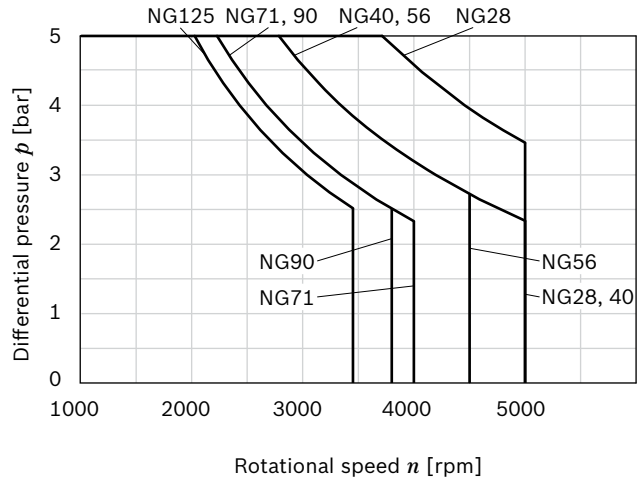

The FKM shaft seal ring may be used for leakage temperatures from -25 °C to +115 °C. For application cases below -25 °C, an NBR shaft seal is required (permissible temperature range: -40 °C to +90 °C).

Working pressure range

Pressure at working port A or B		Definition
Nominal pressure p_{nom}	400 bar	The nominal pressure corresponds to the maximum design pressure.
Maximum pressure p_{max}	450 bar	The maximum pressure corresponds to the maximum working pressure within the single operating period. The sum of the single operating periods must not exceed the total operating period.
Single operating period	10 s	
Total operating period	300 h	
Minimum pressure (high-pressure side)	25 bar	Minimum pressure at the high-pressure side (A or B) which is required to prevent damage to the axial piston unit.
Minimum pressure (low-pressure side)	10 bar above case pressure	Minimum pressure at the low-pressure side (A or B) which is required to prevent damage to the axial piston unit.
Rate of pressure change $R_{A\ max}$	9000 bar/s	Maximum permissible rate of pressure build-up and reduction during a pressure change across the entire pressure range.
Boost pump		
Nominal pressure $p_{Sp\ nom}$	25 bar	
Maximum pressure $p_{Sp\ max}$	40 bar	
Pressure at suction port S (inlet)		
Continuous $p_{S\ min}$ ($v \leq 30\ mm^2/s$)	≥ 0.8 bar absolute	
Momentary, during cold start ($t < 3\ min$)	≥ 0.5 bar absolute	
Maximum pressure $p_{S\ max}$	≤ 5 bar absolute	
Control pressure		
Minimum control pressure $p_{St\ min}$		To ensure the function of the control, a minimum control pressure $p_{St\ min}$ at $n = 2000\ rpm$ is necessary depending on the rotational speed and working pressure
Controls EP, HD, HW	20 bar above case pressure	
Controls DA, DG, EZ, ET	25 bar above case pressure	

▼ Rate of pressure change $R_{A\ max}$

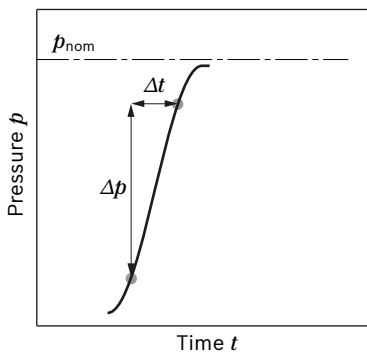

▼ Pressure definition

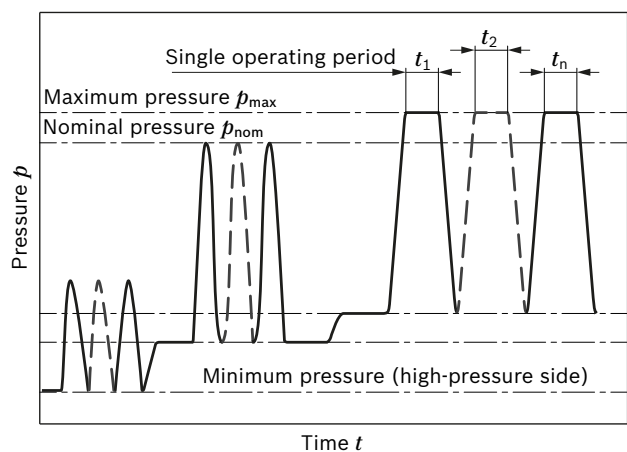

Total operating period = $t_1 + t_2 + \dots + t_n$

Notice

Working pressure range valid when using hydraulic fluids based on mineral oils. Please contact us for values for other hydraulic fluids.

Technical data

Size		NG	28	40	56	71	90	125	180		
Displacement, geometric, per revolution	variable pump	$V_{g \max}$	cm ³	28	40	56	71	90	125	180	
	boost pump (at $p = 20$ bar)	$V_{g Sp}$	cm ³	6.1	8.6	11.6	19.6	19.6	28.3	39.8	
Rotational speed ¹⁾	maximum at $V_{g \max}$	n_{nom}	rpm	4250	4000	3600	3300	3050	2850	2500	
	limited, maximum ²⁾	n_{max1}	rpm	4500	4200	3900	3600	3300	3250	2900	
	intermittent, maximum ³⁾	n_{max2}	rpm	5000	5000	4500	4100	3800	3450	3000	
	minimum	n_{min}	rpm	500	500	500	500	500	500	500	
Flow	at n_{nom} and $V_{g \max}$	q_v	l/min	119	160	202	234	275	356	450	
Power ⁴⁾	at n_{nom} , $V_{g \max}$ and $\Delta p = 400$ bar	P	kW	79	107	134	156	183	238	300	
Torque ⁴⁾	at $V_{g \max}$ and	$\Delta p = 400$ bar	T	Nm	178	255	357	452	573	796	1146
		$\Delta p = 100$ bar	T	Nm	45	64	89	113	143	199	286
Rotary stiffness of drive shaft	S	c	kNm/rad	31.4	69	80.8	98.8	158.1	218.3	244.5	
	T	c	kNm/rad	–	–	95	120.9	–	252.1	318.4	
	A	c	kNm/rad	–	79.6	95.8	142.4	176.8	256.5	–	
	Z	c	kNm/rad	32.8	67.5	78.8	122.8	137	223.7	319.6	
	U	c	kNm/rad	–	50.8	–	–	107.6	–	–	
Moment of inertia for rotary group		J_{TW}	kgm ²	0.0022	0.0038	0.0066	0.0097	0.0149	0.0232	0.0444	
Maximum angular acceleration ⁵⁾		α	rad/s ²	38000	30000	24000	21000	18000	14000	11000	
Case volume		V	l	0.9	1.1	1.5	1.3	1.5	2.1	3.1	
Weight (without through drive) approx.		m	kg	29	31	38	50	60	80	101	

Notice

- ▶ Theoretical values, without efficiency and tolerances; values rounded
- ▶ Operation above the maximum values or below the minimum values may result in a loss of function, a reduced service life or in the destruction of the axial piston unit. Bosch Rexroth recommend testing the loads by means of experiment or calculation / simulation and comparison with the permissible values.

Determining the operating characteristics

Flow	$q_v = \frac{V_g \times n \times \eta_v}{1000}$	[l/min]
Torque	$T = \frac{V_g \times \Delta p}{20 \times \pi \times \eta_{hm}}$	[Nm]
Power	$P = \frac{2 \pi \times T \times n}{60000} = \frac{q_v \times \Delta p}{600 \times \eta_t}$	[kW]

Key

- V_g Displacement per revolution [cm³]
- Δp Differential pressure [bar]
- n Rotational speed [rpm]
- η_v Volumetric efficiency
- η_{hm} Hydraulic-mechanical efficiency
- η_t Total efficiency ($\eta_t = \eta_v \times \eta_{hm}$)

- 1) The values are applicable:
 - for the optimum viscosity range from $n_{opt} = 36$ to $16 \text{ mm}^2/\text{s}$
 - for hydraulic fluid based on mineral oils (for HF hydraulic fluids, observe the technical data in 90225)
- 2) Valid at half corner power (e.g. at $V_{g \max}$ and $p_N/2$)
- 3) Valid at $\Delta p = 70$ to 150 bar or $\Delta p < 300$ bar and $t < 0.1$ s
- 4) Without boost pump

- 5) The data are valid for values between the minimum required and maximum permissible rotational speed.
Valid for external excitation (e.g. diesel engine 2 to 8 times rotary frequency, cardan shaft twice the rotary frequency).
The limit value is only valid for a single pump.
The load capacity of the connecting parts must be considered.

Permissible radial and axial forces on the drive shaft
▼ Splined shaft DIN 5480

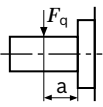
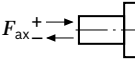
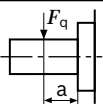
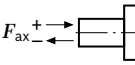
Size	NG		28	40	40	56	56	71	71	
Drive shaft			W25	W30	W35	W30	W35	W35	W40	
Maximum radial force at distance a (from shaft collar)		$F_{q \max}$	N	3030	3608	3092	5051	4329	5489	4803
		a	mm	17.5	17.5	20	17.5	20	20	22.5
Maximum axial force		$+ F_{ax \max}$	N	1557	2120	2120	2910	2910	4242	4242
		$- F_{ax \max}$	N	417	880	880	1490	1490	2758	2758
Size	NG		90	90	125	125	180			
Drive shaft			W35	W45	W40	W45	W50			
Maximum radial force at distance a (from shaft collar)		$F_{q \max}$	N	6957	5411	8455	7516	9740		
		a	mm	20	25	22.5	25	27.5		
Maximum axial force		$+ F_{ax \max}$	N	4330	4330	6053	6053	7500		
		$- F_{ax \max}$	N	2670	2670	3547	3547	4500		

▼ Splined shaft ANSI B92.1a

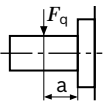
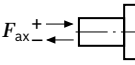
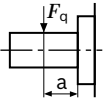
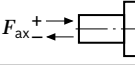
Size	NG		28	40	40	56	56	71	71	
Drive shaft		in	1	1	1 1/4	1 1/4	1 3/8	1 1/4	1 3/8	
Maximum radial force at distance a (from shaft collar)		$F_{q \max}$	N	2983	4261	3409	4772	4338	6050	5500
		a	mm	19	19	24	24	24	24	24
Maximum axial force		$+ F_{ax \max}$	N	1557	2120	2120	2910	2910	4242	4242
		$- F_{ax \max}$	N	417	880	880	1490	1490	2758	2758
Size	NG		90	90	125	125	180	180		
Drive shaft		in	1 1/4	1 3/4	1 3/4	2	1 3/4	2 1/4		
Maximum radial force at distance a (from shaft collar)		$F_{q \max}$	N	7670	5478	7609	6658	10956	8522	
		a	mm	24	33.5	33.5	40	33.5	40	
Maximum axial force		$+ F_{ax \max}$	N	4330	4330	6053	6053	7500	7500	
		$- F_{ax \max}$	N	2670	2670	3547	3547	4500	4500	

Notice

- ▶ The axial and radial forces generally influence the service life of the bearings.
- ▶ Special requirements apply in the case of belt drive and cardan shaft. Please contact us.

Permissible input and through-drive torques

Size	NG		28	40	56	71	90	125	180	
Torque at $V_{g \max}$ and $\Delta p = 400 \text{ bar}^{1)}$	T	Nm	178	255	357	452	573	796	1146	
Maximum input torque at drive shaft ²⁾										
DIN 5480	Z	$T_{E \max}$	Nm	352	522	522	912	912	1460	3140
				W25	W30	W30	W35	W35	W40	W50
	A	$T_{E \max}$	Nm	–	912	912	1460	2190	2190	–
					W35	W35	W40	W45	W45	
ANSI B92.1a (SAE J744)	S	$T_{E \max}$	Nm	314	602	602	602	1640	1640	1640
			in	1	1 1/4	1 1/4	1 1/4	1 3/4	1 3/4	1 3/4
	T	$T_{E \max}$	Nm	–	–	970	970	–	2670	4070
			in	–	–	1 3/8	1 3/8	–	2	2 1/4
U ³⁾	$T_{E \max}$	Nm	–	314	–	–	602	–	–	
		in	–	1	–	–	1 1/4	–	–	
Maximum through-drive torque ⁴⁾	$T_{D \max}$	Nm	231	314	521	660	822	1110	1760	

▼ **Distribution of torques**

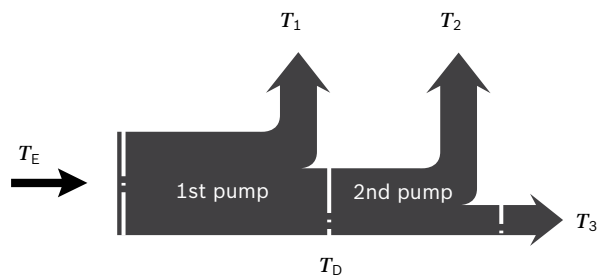

Torque at 1st pump	T_1
Torque at 2nd pump	T_2
Torque at 3rd pump	T_3
Input torque	$T_E = T_1 + T_2 + T_3$
	$T_E < T_{E \max}$
Through-drive torque	$T_D = T_2 + T_3$
	$T_D < T_{D \max}$

- 1) Efficiency not considered
- 2) For drive shafts free of radial force
- 3) Shaft "U" is only permitted as drive shaft on the 2nd pump on a combination pump of the same size.
- 4) Note maximum input torque for shaft S!

NV – Version without control module

The mounting surface for the control module is machined and sealed with the standard seal for control modules and a cover plate. This version is ready for retrofitting to control modules (HD, HW, EP, EZ). When used directly for “DA” control and in combinations with “DA” control, the appropriate adjustments must be made to the spring assembly of the adjustment cylinder and control plate.

▼ Standard version¹⁾

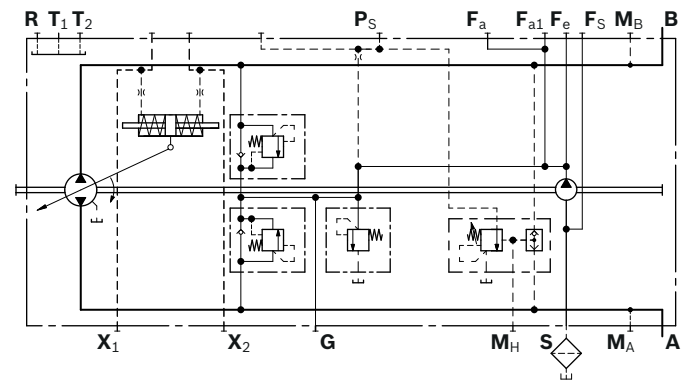

DG – Hydraulic control, direct operated

With the direct operated hydraulic control (DG), the output flow of the pump is controlled by a hydraulic control pressure, applied directly to the stroking piston through either port **X₁** or **X₂**.

Flow direction is determined by which control pressure port is pressurized (refer to table below).

Pump displacement is infinitely variable and proportional to the applied control pressure, but is also influenced by system pressure and pump drive speed.

In order to use the optional built-in pressure cut-off, port **P_s** must be used as the control pressure source for the selected control module.

See page 60 for a functional description of the pressure cut-off.

Maximum permissible control pressure: 40 bar

Use of the DG control requires a review of the engine and vehicle parameters to ensure that the pump is set up correctly. We recommend that all DG applications be reviewed by a Bosch Rexroth application engineer.

If the pump is also equipped with a DA control valve (see page 19), automotive operation is possible for travel drives.

▼ Standard version¹⁾

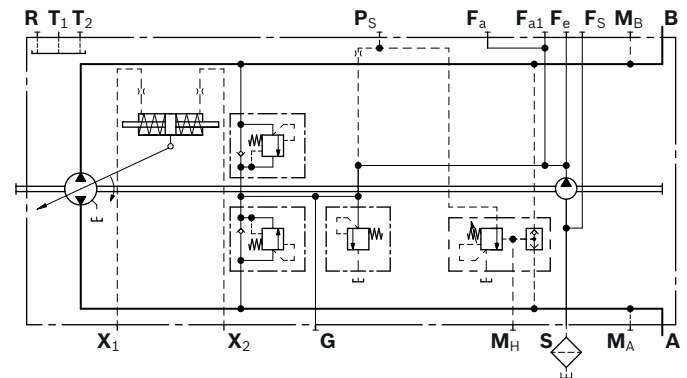

▼ Version with DA control valve¹⁾

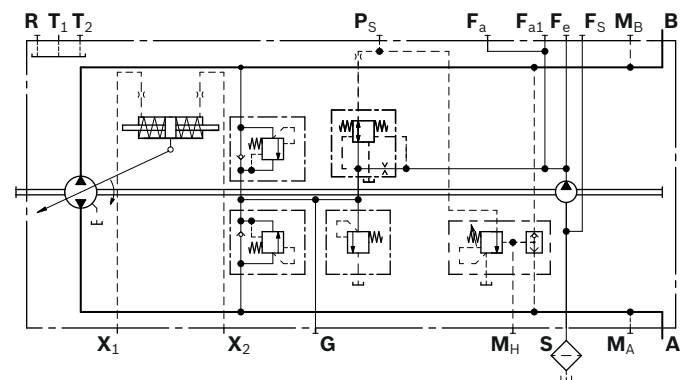

Correlation of direction of rotation, control and flow direction

Direction of rotation	clockwise				counter-clockwise			
Size	28 to 56		71 to 180		28 to 56		71 to 180	
Control pressure	X₁	X₂	X₁	X₂	X₁	X₂	X₁	X₂
Flow direction	A to B	B to A	B to A	A to B	B to A	A to B	A to B	B to A
Working pressure	M_B	M_A	M_A	M_B	M_A	M_B	M_B	M_A

¹⁾ Size 28 without port **F_{a1}** and **F_s**

HD – Proportional control, hydraulic, pilot-pressure related

The output flow of the pump is infinitely variable between 0 and 100%, proportional to the difference in pilot pressure applied to the two pilot pressure ports (Y_1 and Y_2).

The pilot signal, coming from an external source, is a pressure signal. Flow is negligible, as the pilot signal acts only on the control spool of the control valve.

This control spool then directs control oil into and out of the stroking cylinder to adjust pump displacement as required.

A feedback lever connected to the stroking piston maintains the pump flow for any given pilot signal within the control range.

If the pump is also equipped with a DA control valve (see page 19), automotive operation is possible for travel drives.

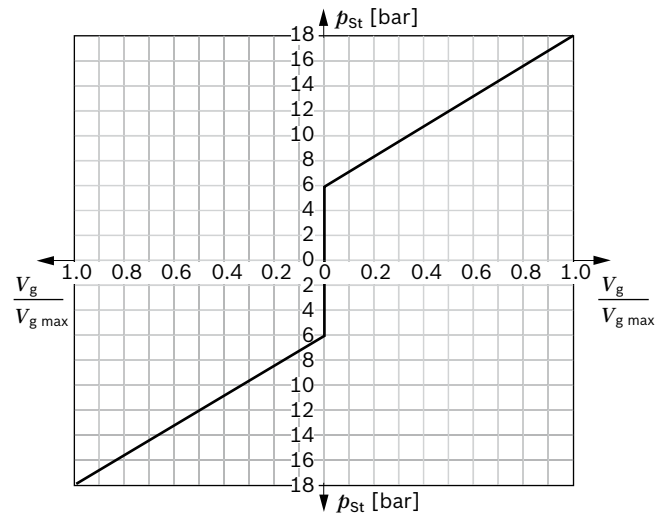

- ▶ V_g = Displacement at p_{St}
 $V_{g\ max}$ = Displacement at $p_{St} = 18$ bar
- ▶ Pilot signal $p_{St} = 6$ to 18 bar (at port Y_1, Y_2)
- ▶ Start of control at 6 bar
- ▶ End of control at 18 bar (maximum displacement $V_{g\ max}$)

Notice

In the neutral position, the HD control module must be vented to reservoir via the external pilot control device.

▼ Standard version¹⁾

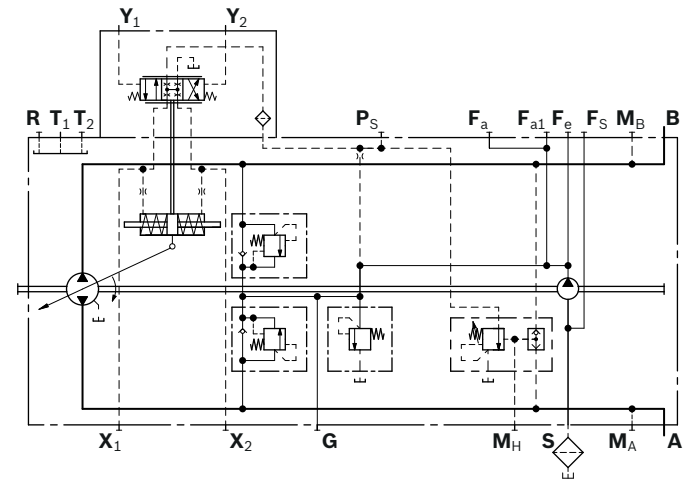

▼ Version with DA control valve¹⁾

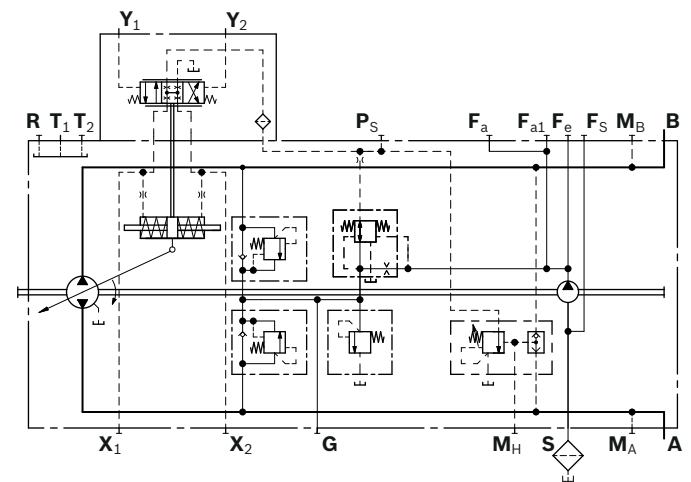

1) Size 28 without port F_{a1} and F_s

Correlation of direction of rotation, control and flow direction									
Direction of rotation	clockwise				counter-clockwise				
Size	28 to 56		71 to 180		28 to 56		71 to 180		
Pilot signal	Y₁	Y₂	Y₁	Y₂	Y₁	Y₂	Y₁	Y₂	
Control pressure	X₁	X₂	X₁	X₂	X₁	X₂	X₁	X₂	
Flow direction	A to B	B to A	B to A	A to B	B to A	A to B	A to B	B to A	
Working pressure	M_B	M_A	M_A	M_B	M_A	M_B	M_B	M_A	

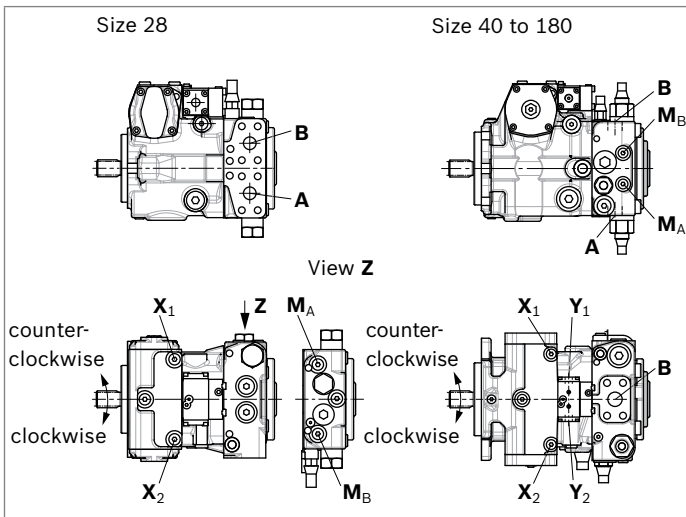

HW – Proportional control, hydraulic, mechanical servo

The output flow of the pump is infinitely variable between 0 and 100%, proportional to the swivel angle of the control lever.

A feedback lever connected to the stroking piston maintains the pump flow for any given position of the control lever. If the pump is also equipped with a DA control valve (see page 19), automotive operation is possible for travel drives.

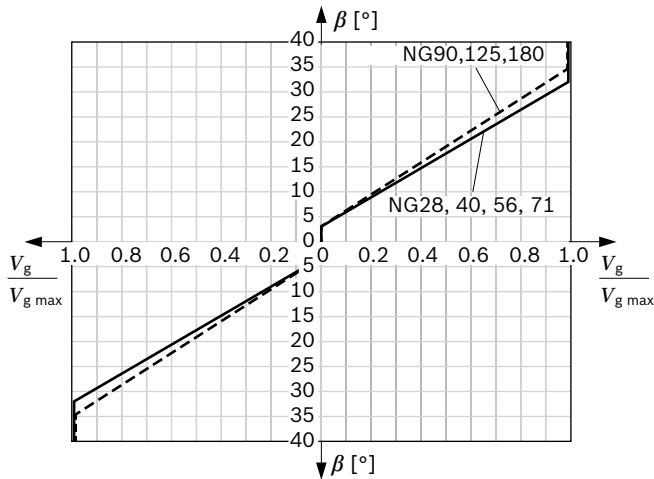

Swivel angle β at the control lever for pump displacement change:

- ▶ Start of control at $\beta = \pm 3^\circ$
- ▶ End of control at β (max. displacement $V_{g \max}$)
 - Size 28 to 71 at $\pm 32^\circ$
 - Size 90 to 180 at $\pm 34.5^\circ$
- ▶ Rotational limit β of the control lever (internal) $\pm 38^\circ$

The maximum required torque at the lever is 170 Ncm. To prevent damage to the HW control module, a positive mechanical stop of $36.5^\circ \pm 1$ must be provided for the HW control lever on the customer side.

Notices

- ▶ Spring centering enables the pump, depending on pressure and speed, to move automatically to the neutral position ($V_g = 0$) as soon as there is no longer any torque on the control lever of the HW control module.
- ▶ If necessary, the position of the lever can be changed. The procedure is defined in the instruction manual.
- ▶ On delivery, the position of the lever may differ from that shown in the drawing.

Option: Neutral position switch

The switch contact in the neutral position switch is closed when the control lever on the HW control module is in its neutral position. The switch opens when the control lever is moved out of the central position in either direction. Thus, the neutral position switch provides a monitoring function for drive units that require the pump to be in the neutral position during certain operating conditions (e.g. starting diesel engines).

Technical Data

Load capacity	20 A (continuous), without switching operations
Switching capacity	15 A / 32 V (resistive load) 4 A / 32 V (inductive load)
Connector version	DEUTSCH DT04-2P-EP04 (mating connector, see page 68)

▼ Standard version¹⁾

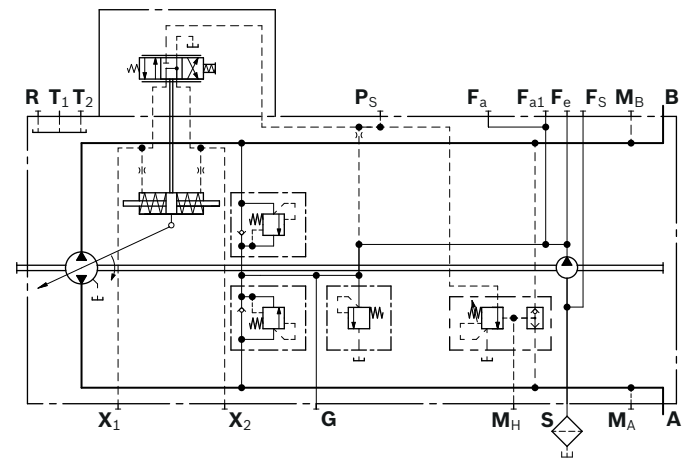

▼ Version with DA control valve and neutral position switch¹⁾

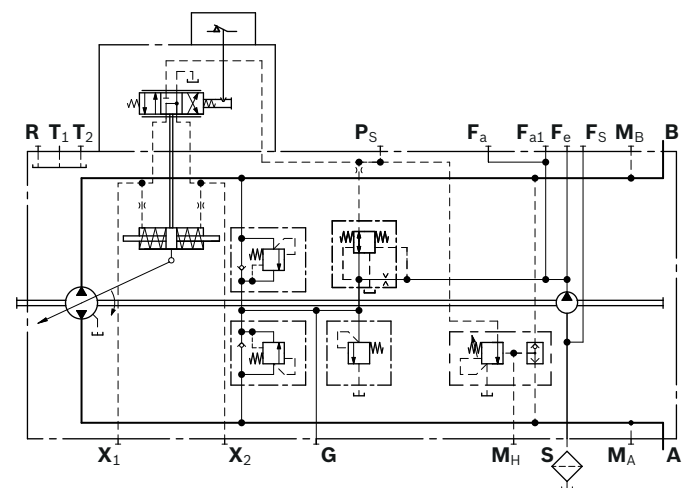

1) Size 28 without port F_{a1} and F_s

Correlation of direction of rotation, control and flow direction								
Direction of rotation	clockwise				counter-clockwise			
Size	28 to 56		71 to 180		28 to 56		71 to 180	
Lever direction	a	b	a	b	a	b	a	b
Control pressure	X₂	X₁	X₂	X₁	X₂	X₁	X₂	X₁
Flow direction	B to A	A to B	A to B	B to A	A to B	B to A	B to A	A to B
Working pressure	M_A	M_B	M_B	M_A	M_B	M_A	M_A	M_B

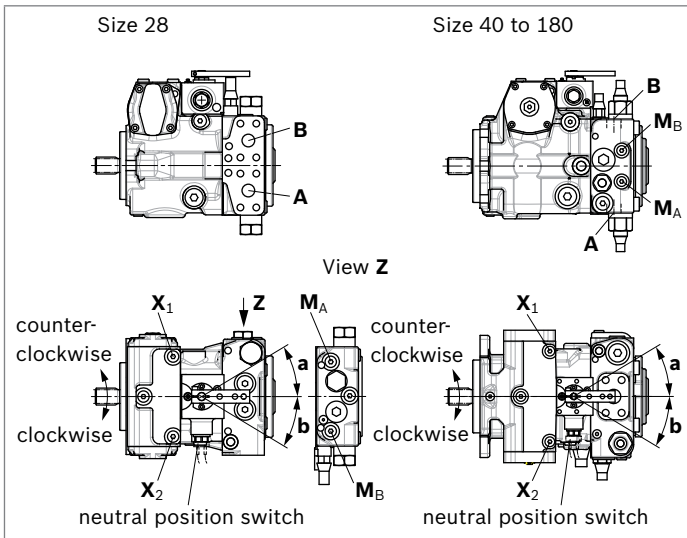

EP – Proportional control, electric

The output flow of the pump is infinitely variable between 0 and 100%, proportional to the electrical current supplied to solenoid **a** or **b**.

The electrical energy is converted into a force acting on the control spool.

This control spool then directs control oil into and out of the stroking cylinder to adjust pump displacement as required.

A feedback lever connected to the stroking piston maintains the pump flow for any given current within the control range.

If the pump is also equipped with a DA control valve (see page 19), automotive operation is possible for travel drives.

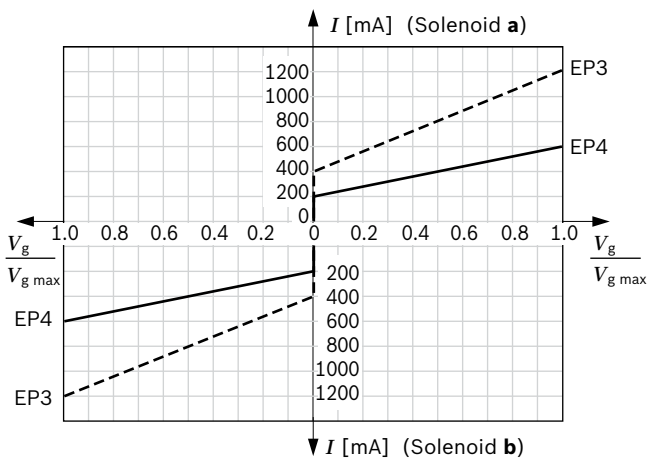

Notice

The proportional solenoids do not have manual override. Proportional solenoids with manual override and spring return are available on request.

Technical data, solenoid	EP3	EP4
Voltage	12 V ($\pm 20\%$)	24 V ($\pm 20\%$)
Control current		
Start of control at $V_g = 0$	400 mA	200 mA
End of control at $V_g \max$	1200 mA	600 mA
Current limit	1.54 A	0.77 A
Nominal resistance (at 20 °C)	5.5 Ω	22.7 Ω
Dither		
Frequency	100 Hz	100 Hz
Minimum oscillation range ¹⁾	240 mA	120 mA
Duty cycle	100%	100%
Type of protection: see connector version page 68		

Various BODAS controllers with application software and amplifiers are available for controlling the proportional solenoids.

Further information can also be found on the Internet at www.boschrexroth.com/mobile-electronics

▼ Standard version²⁾

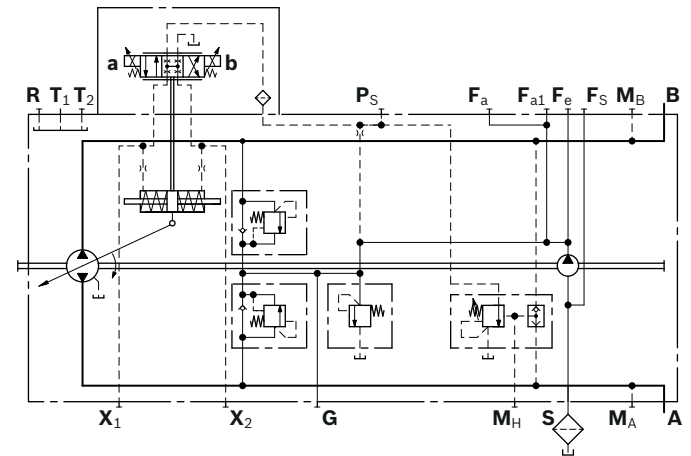

▼ Version with DA control valve²⁾

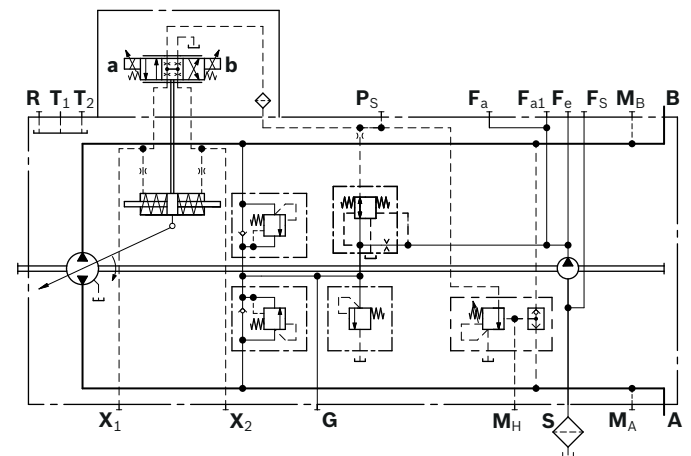

1) Minimum required oscillation range of the control current ΔI_{p-p} (peak to peak) within the respective control range (start of control to end of control)

2) Size 28 without port **F_{a1}** and **F_s**

Correlation of direction of rotation, control and flow direction								
Direction of rotation	clockwise				counter-clockwise			
Size	28 to 56		71 to 180		28 to 56		71 to 180	
Actuation of solenoid	a	b	a	b	a	b	a	b
Control pressure	X₁	X₂	X₁	X₂	X₁	X₂	X₁	X₂
Flow direction	A to B	B to A	B to A	A to B	B to A	A to B	A to B	B to A
Working pressure	M_B	M_A	M_A	M_B	M_A	M_B	M_B	M_A

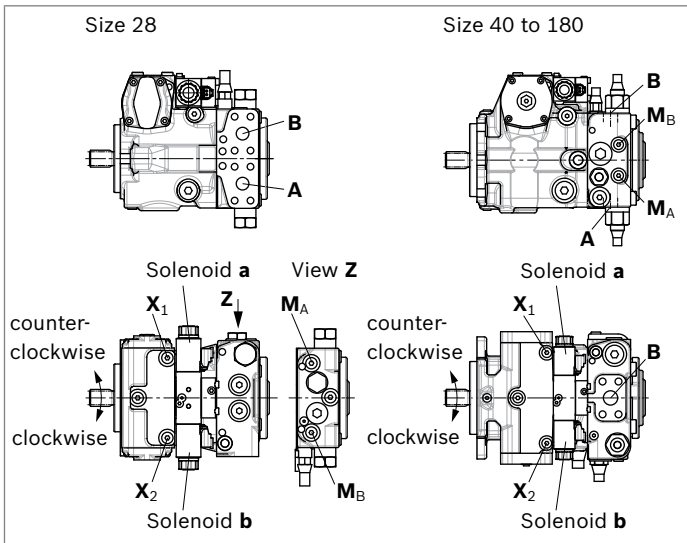

EZ – Two-point control, electric

By actuating either switching solenoid **a** or **b**, internal control pressure is applied directly to the stroking piston and the pump swivels to maximum displacement. The EZ control enables pump flow to be switched between $V_g = 0$ and $V_{g \max}$.

Flow direction is determined by which solenoid is energized.

Technical data, solenoid	EZ1	EZ2
Voltage	12 V ($\pm 20\%$)	24 V ($\pm 20\%$)
Neutral position $V_g = 0$	de-energized	de-energized
Position $V_g \max$	energized	energized
Nominal resistance (at 20 °C)	5.5 Ω	21.7 Ω
Nominal power	26.2 W	26.5 W
Minimum active current required	1.32 A	0.67 A
Duty cycle	100%	100%
Type of protection: see connector version page 68		

▼ Standard version¹⁾

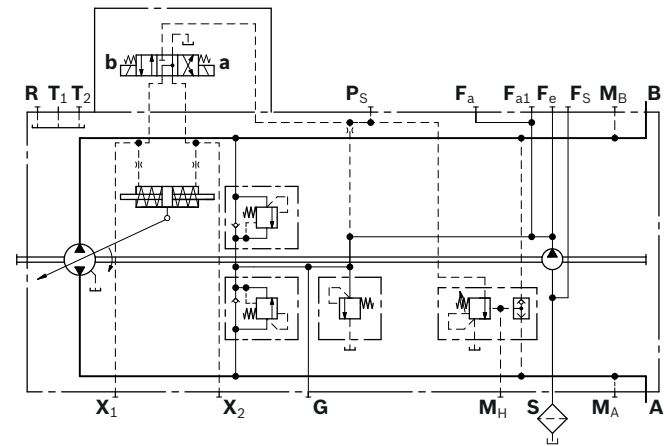

Correlation of direction of rotation, control and flow direction								
Direction of rotation	clockwise				counter-clockwise			
	Size 28 to 56		Size 71 to 180		Size 28 to 56		Size 71 to 180	
Actuation of solenoid	a	b	a	b	a	b	a	b
Control pressure	X₂	X₁	X₂	X₁	X₂	X₁	X₂	X₁
Flow direction	B to A	A to B	A to B	B to A	A to B	B to A	B to A	A to B
Working pressure	M_A	M_B	M_B	M_A	M_B	M_A	M_A	M_B

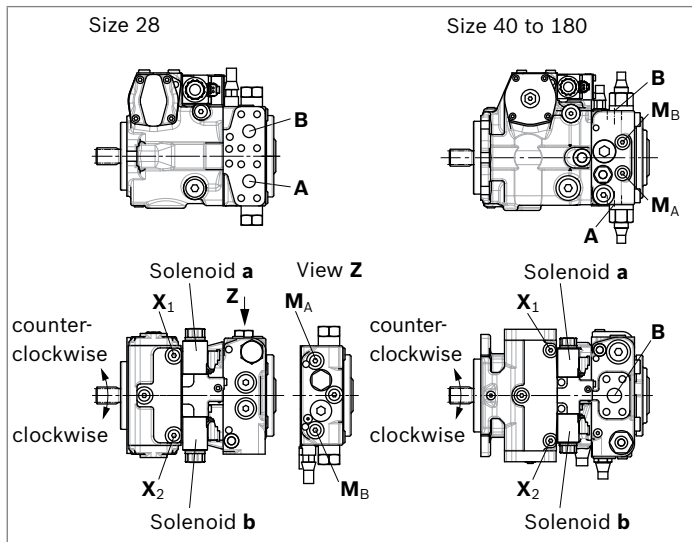

1) Size 28 without port **F_{a1}** and **F_s**

DA – Automatic control, speed related

The DA closed loop control is an engine speed-dependent system for travel drives. The built-in DA control valve generates a pilot pressure that is proportional to pump (engine) drive speed. This pilot pressure is directed to the stroking cylinder of the pump by an electromagnetically actuated 4/3-way directional valve. The pump displacement is infinitely variable in each flow direction and is influenced by both pump drive speed and system pressure. The flow direction (e.g. machine moving forward or backward) is determined by either solenoid **a** or **b** being activated. Increasing the pump drive speed generates a higher pilot pressure from the DA control valve, with a subsequent increase in pump flow.

Depending on the selected pump operating characteristics, increasing system pressure (e.g. machine load) causes the pump to swivel back towards a smaller displacement. An overload protection for the engine (against stalling) is achieved by combining this pressure-dependent reduction in pump stroke with a reduction in pilot pressure as the engine speed drops.

Any additional power requirement, e.g. for hydraulic functions from attachments, could cause the engine speed to drop further. This will cause a further reduction in pilot pressure and thus of the pump displacement. Automatic power distribution and full exploitation of the available power are achieved in this way, both for the travel drive and for the implement hydraulics, with priority given to the implement hydraulics.

Various override options are available for DA control function to allow controlled operation of the implement hydraulics with high rpm at reduced vehicle speed.

The DA control valve can also be used in pumps with EP, DG, HW and HD control modules to protect the combustion engine against overload.

Notices

DA closed loop control is only suitable for certain types of travel drive systems and requires review of the engine and vehicle parameters to ensure that the pump is used correctly and that machine operation is safe and efficient. We recommend that all DA applications be reviewed by a Bosch Rexroth application engineer.

Technical data, solenoid	DA1	DA2
Voltage	12 V ($\pm 20\%$)	24 V ($\pm 20\%$)
Neutral position $V_g = 0$	de-energized	de-energized
Position $V_g \text{ max}$	energized	energized
Nominal resistance (at 20 °C)	5.5 Ω	21.7 Ω
Nominal power	26.2 W	26.5 W
Minimum required active current	1.32 A	0.67 A
Duty cycle	100%	100%
Type of protection: see connector version page 68		

DA..2 – DA control valve, fixed setting

Pilot pressure is generated in relation to drive speed.

▼ DA control valve, fixed setting, DA1D2/DA2D2¹⁾

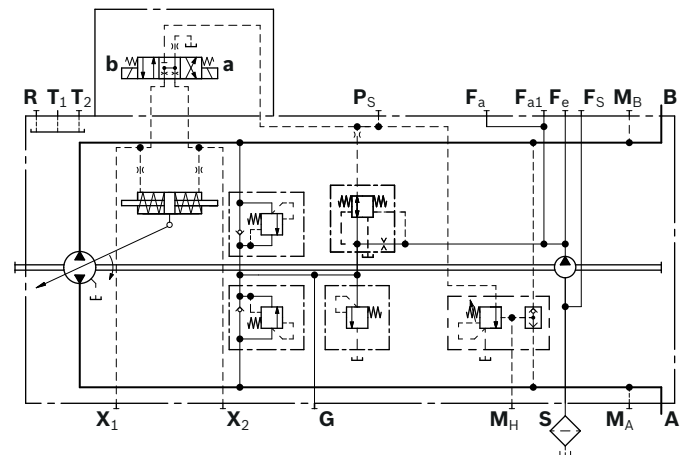

1) Size 28 without port F_{a1} and F_s

DA..3 – DA control valve, mechanically adjustable with position lever

Pilot pressure is generated in relation to drive speed.

Any reduction of pilot pressure possible, independently of drive speed, through mechanical actuation of the position lever (inch function).

The maximum permissible actuation torque at the position lever is $T_{max} = 4 \text{ Nm}$.

Maximum angle of rotation 70° , lever position: any.

DA..3R

Direction of actuation of the position lever: clockwise

DA..3L

Direction of actuation of the position lever: counter-clockwise

▼ **Circuit diagram DA1D3/DA2D3¹⁾**

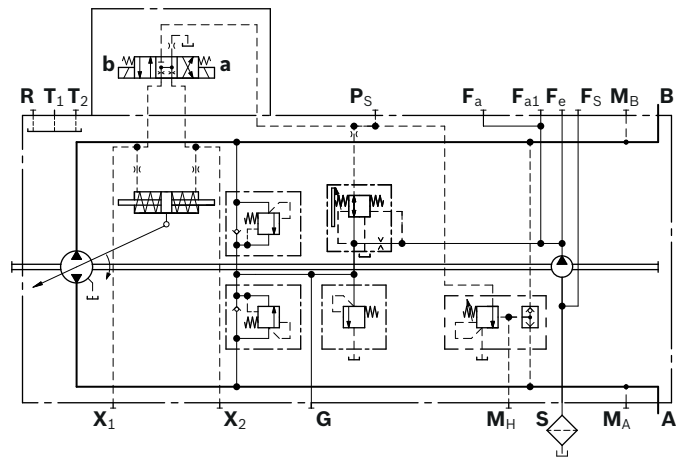

DA..7 – DA control valve, fixed setting, ports for pilot control device as inch valve

Any reduction of the pilot pressure possible, independent of the drive speed is achieved by the mechanical actuation of the pilot control device.

The pilot control device is installed separately from the pump (for example in the driver's cabin) and connected to the pump by two hydraulic control lines via ports **P_S** and **Y**. A suitable pilot control device must be ordered separately and is not included in the scope of delivery.

Note: Rotary inch valves, see page 69.

▼ **Circuit diagram DA1D7/DA2D7¹⁾**

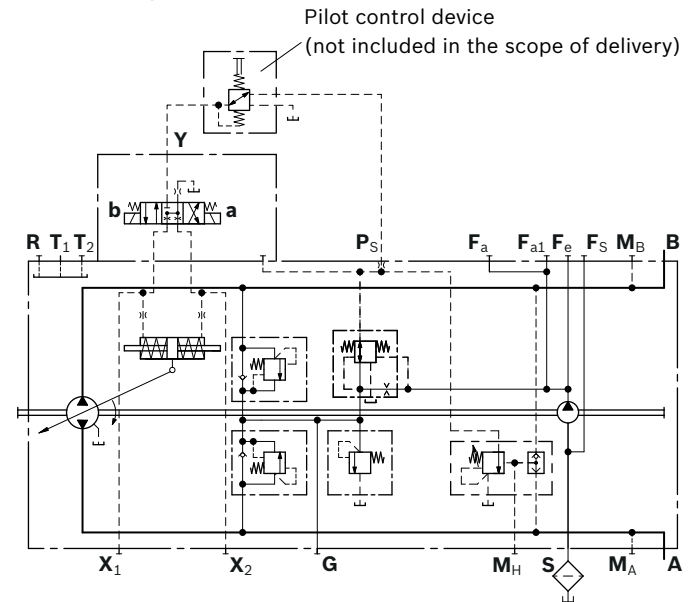

1) Size 28 without port **F_{a1}** and **F_s**

DA..8 – DA control valve, fixed setting and brake inch valve mounted

Only for pumps with DA control module

- ▶ Version with throttle valve size 28, 40, 56, 71
 - ▶ Version with pressure reducing valve size 90, 125, 180
- Permits reduction of the pilot pressure, independently of the drive speed via hydraulic control (port **Z**).

Control at port **Z** by means of brake fluid based on mineral oil.

▼ **Circuit diagram DA1D8/DA2D8 with throttle valve¹⁾**

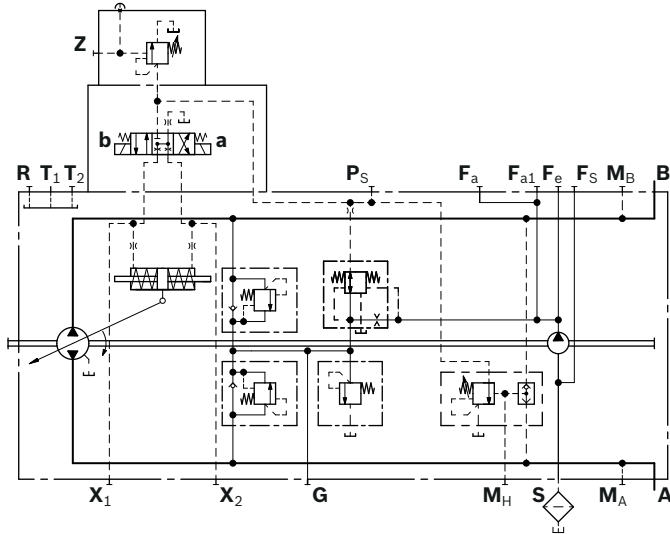

▼ **Circuit diagram DA1D8/DA2D8 with pressure reducing valve¹⁾**

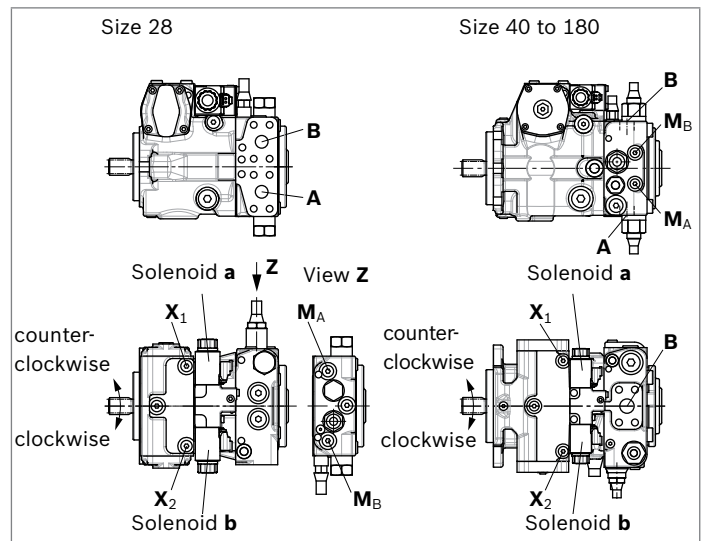
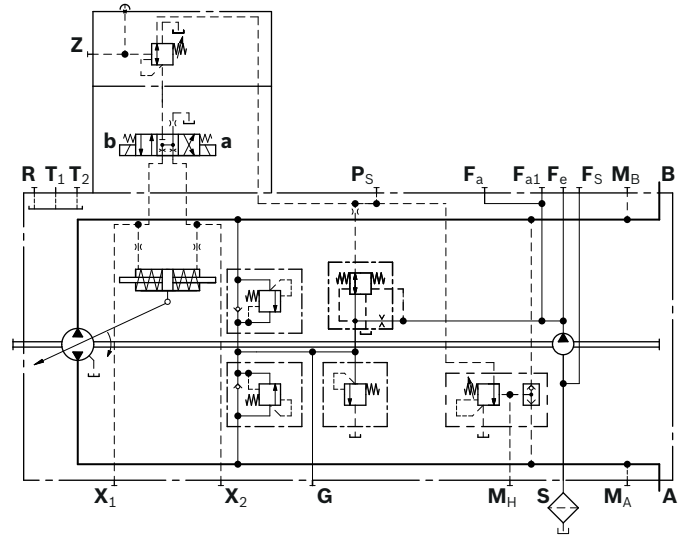

Correlation of direction of rotation, control and flow direction									
Direction of rotation	clockwise				counter-clockwise				
Size	28 to 56		71 to 180		28 to 56		71 to 180		
Actuation of solenoid	a	b	a	b	a	b	a	b	
Control pressure	X₂	X₁	X₂	X₁	X₂	X₁	X₂	X₁	
Flow direction	B to A	A to B	A to B	B to A	A to B	B to A	B to A	A to B	
Working pressure	M_A	M_B	M_B	M_A	M_B	M_A	M_A	M_B	

¹⁾ Size 28 without port **F_{a1}** and **F_S**

ET – Electric control, direct operated

The output flow of the pump is infinitely variable between 0 to 100%. Depending on the preselected current I at solenoids **a** and **b** of the pressure reducing valves, the stroking cylinder of the pump is proportionally supplied with control pressure. The two control pressures X_1 and X_2 can be controlled independently. The pump displacement that arises at a certain control current is dependent on the speed and working pressure of the pump. A different flow direction is associated with each pressure reducing valve. Maximum permissible control pressure P_S : 40 bar.

Technical data, solenoid	ET5	ET6
Voltage	12 V ($\pm 20\%$)	24 V ($\pm 20\%$)
Current limit	1.54 A	0.77 A
Nominal resistance (at 20 °C)	5.5 Ω	22.7 Ω
Dither		
Frequency	100 Hz	100 Hz
Minimum oscillation range ¹⁾	240 mA	120 mA
Duty cycle	100%	100%
Type of protection: see connector version page 68		

▼ Standard version¹⁾

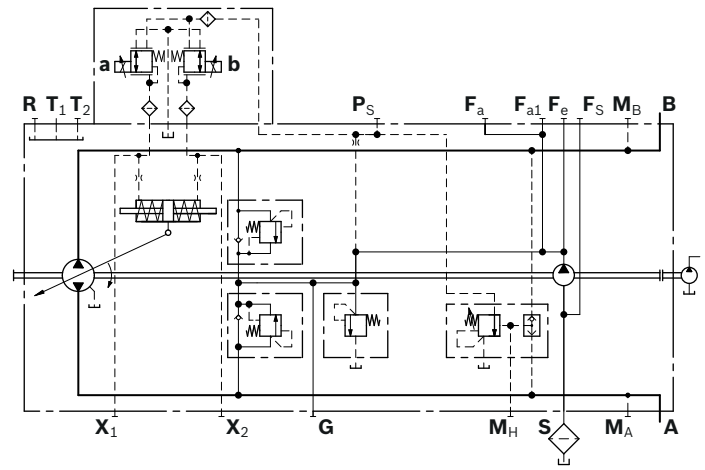

Correlation of direction of rotation, control and flow direction									
Direction of rotation	clockwise				counter-clockwise				
Size	28 to 56		71		28 to 56		71		
Actuation of solenoid	a	b	a	b	a	b	a	b	b
Control pressure	X_1	X_2	X_1	X_2	X_1	X_2	X_1	X_2	X_2
Flow direction	A to B	B to A	B to A	A to B	B to A	A to B	A to B	A to B	B to A
Working pressure	M_B	M_A	M_A	M_B	M_A	M_B	M_B	M_B	M_A

1) Size 28 without port F_{a1} and F_s

Dimensions, size 28

NV – Version without control module

Standard: SAE working port **A** and **B**, same side right, suction port **S** bottom (10)

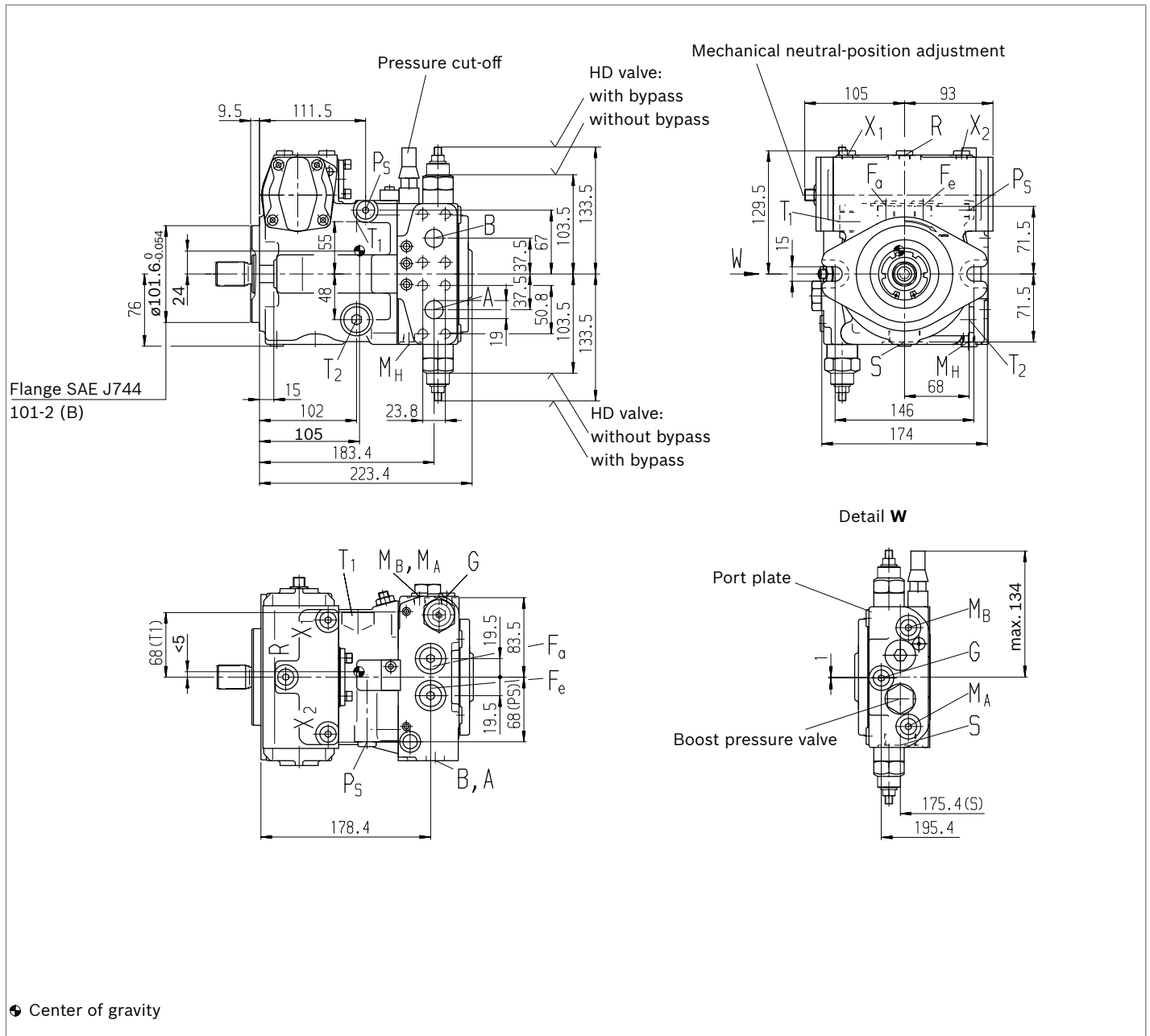

Notice

Option: SAE working port **A** and **B**, same side left, suction port **S** top (13): Port plate 10 rotated through 180°, installation drawing on request

▼ **Splined shaft DIN 5480**

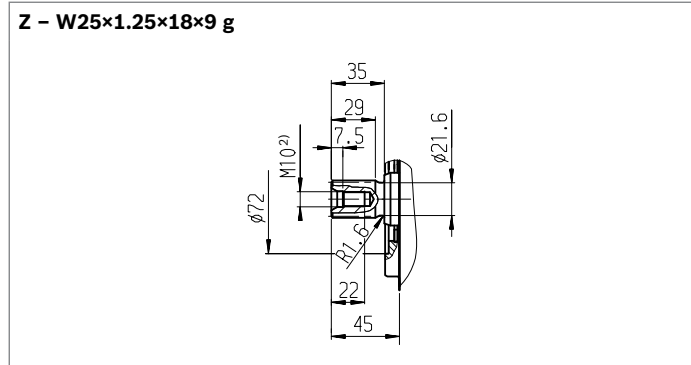

▼ **Splined shaft ANSI B92.1a**

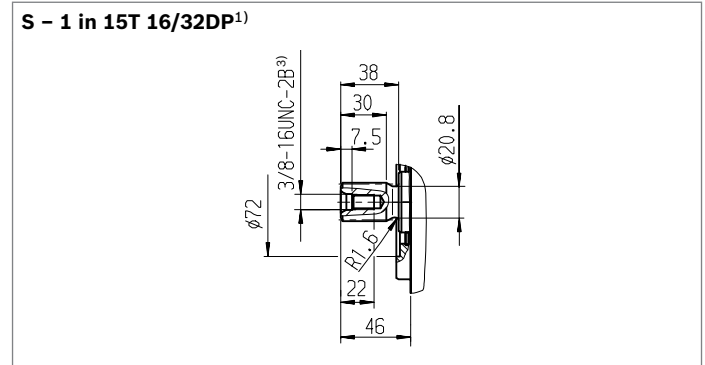

Ports	Standard	Size	p_{max} [bar] ⁴⁾	State ¹⁰⁾
A, B	Working port Fastening thread	SAEJ518 ⁵⁾ DIN 13	3/4 in M10 × 1.5; 17 deep	450 O
S	Suction port	DIN 3852 ⁸⁾	M33 × 2; 18 deep	5 O ⁶⁾
T₁	Drain port	DIN 3852 ⁸⁾	M22 × 1.5; 14 deep	3 O ⁷⁾
T₂	Drain port	DIN 3852 ⁸⁾	M22 × 1.5; 14 deep	3 X ⁷⁾
R	Air bleed port	DIN 3852 ⁸⁾	M12 × 1.5; 12 deep	3 X
X₁, X₂	Control pressure port (upstream of orifice)	DIN 3852 ⁸⁾	M12 × 1.5; 12 deep	40 X
X₁, X₂	Control pressure port (upstream of orifice, DG only)	DIN 3852 ⁸⁾	M12 × 1.5; 12 deep	40 O
X₃, X₄⁹⁾	Stroking chamber pressure port	DIN 3852 ⁸⁾	M12 × 1.5; 12 deep	40 X
G	Boost pressure port inlet	DIN 3852 ⁸⁾	M12 × 1.5; 12 deep	40 X
P_s	Pilot pressure port	DIN 3852 ⁸⁾	M14 × 1.5; 12 deep	40 X
P_s	Pilot pressure port (DA..7 only)	DIN 3852 ⁸⁾	M14 × 1.5; 12 deep	40 O
Y	Pilot pressure port outlet (DA..7 only)	DIN 3852 ⁸⁾	M14 × 1.5; 12 deep	40 O
M_A, M_B	Measuring port pressure A, B	DIN 3852 ⁸⁾	M12 × 1.5; 12 deep	450 X
M_H	Measuring port, high pressure	DIN 3852 ⁸⁾	M12 × 1.5; 12 deep	450 X
F_a	Boost pressure port inlet	DIN 3852 ⁸⁾	M18 × 1.5; 12 deep	40 X
F_e	Boost pressure port outlet	DIN 3852 ⁸⁾	M18 × 1.5; 12 deep	40 X
Y₁, Y₂	Pilot pressure port (pilot signal HD only)	DIN 3852 ⁸⁾	M14 × 1.5; 12 deep	40 O
Z	Pilot pressure port (inch signal DA..8 only)	DIN 3852 ⁸⁾	M10 × 1; 8 deep	40 X

- 1) Involute spline according to ANSI B92.1a, 30° pressure angle, flat root, side fit, tolerance class 5
- 2) Center bore according to DIN 332 (thread according to DIN 13)
- 3) Thread according to ASME B1.1
- 4) Depending on the application, momentary pressure peaks can occur. Keep this in mind when selecting measuring devices and fittings.
- 5) Only dimensions according to SAE J518, metric fastening thread is a deviation from the standard.

- 6) Plugged at external boost pressure supply.
- 7) Depending on installation position, **T₁** or **T₂** must be connected (see also installation instructions on page 71).
- 8) The countersink can be deeper than as specified in the standard.
- 9) Optional, see page 62
- 10) O = Must be connected (plugged when delivered)
X = Plugged (observe installation instructions)

▼ **HD** – Proportional control, hydraulic, pilot-pressure related

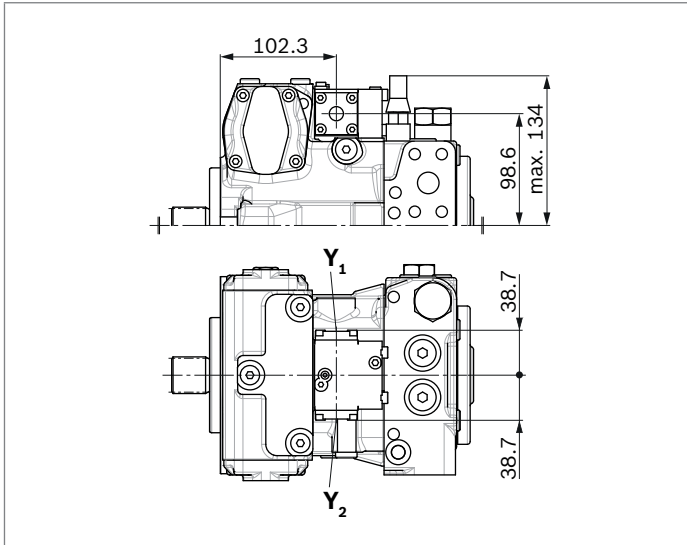

▼ **HW** – Proportional control, hydraulic, mechanical servo

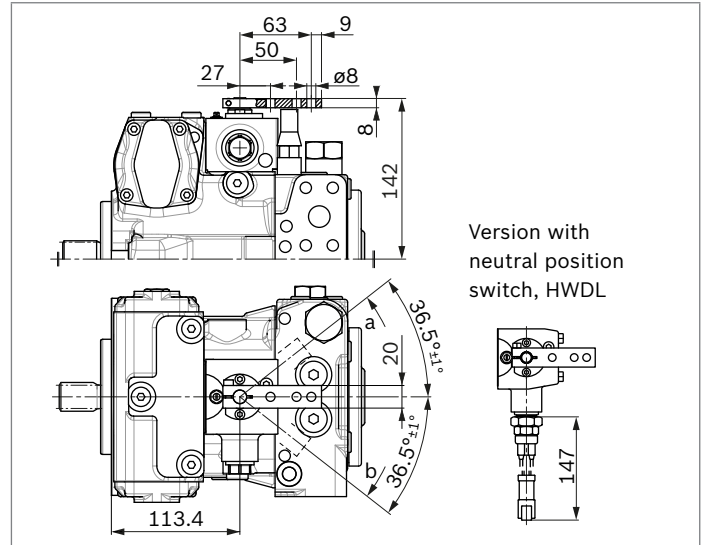

▼ **EP** – Proportional control, electric

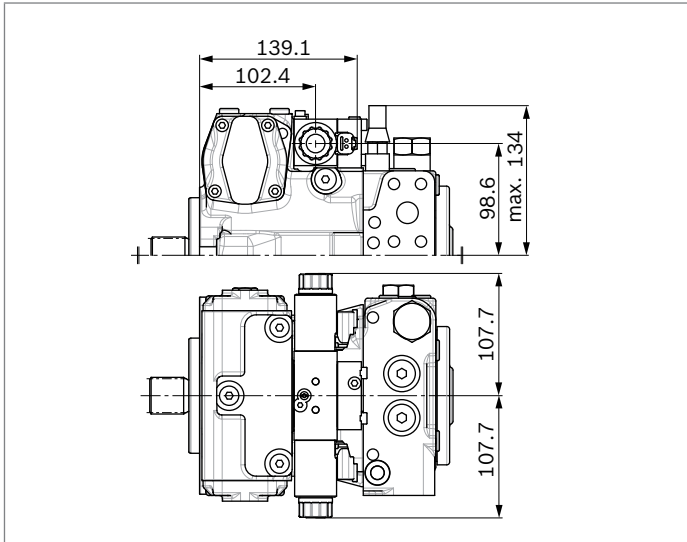

▼ **EZ** – Two-point control, electric

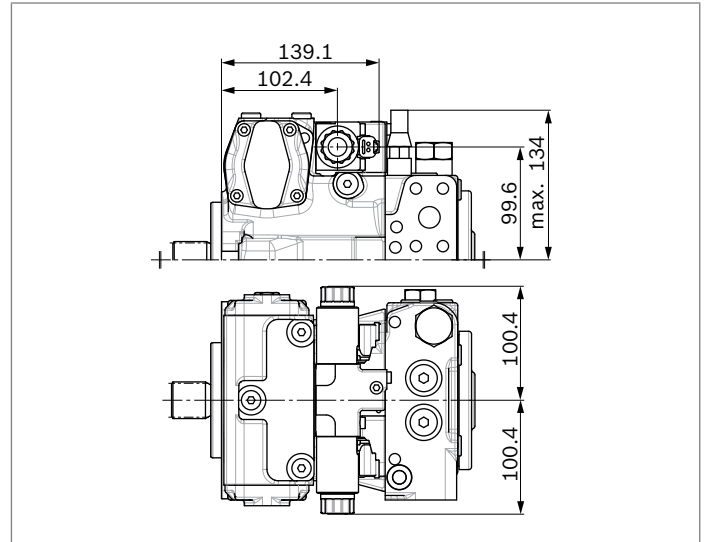

▼ **DG** – Hydraulic control, direct operated

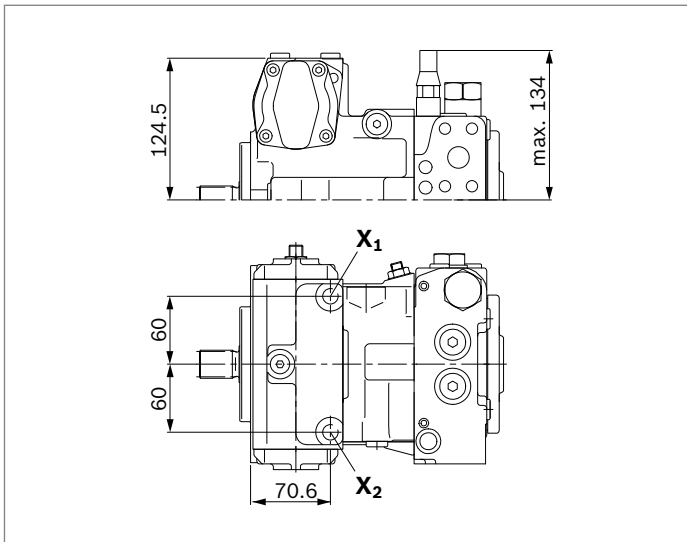

DA control valve

▼ **DA..2** – fixed setting

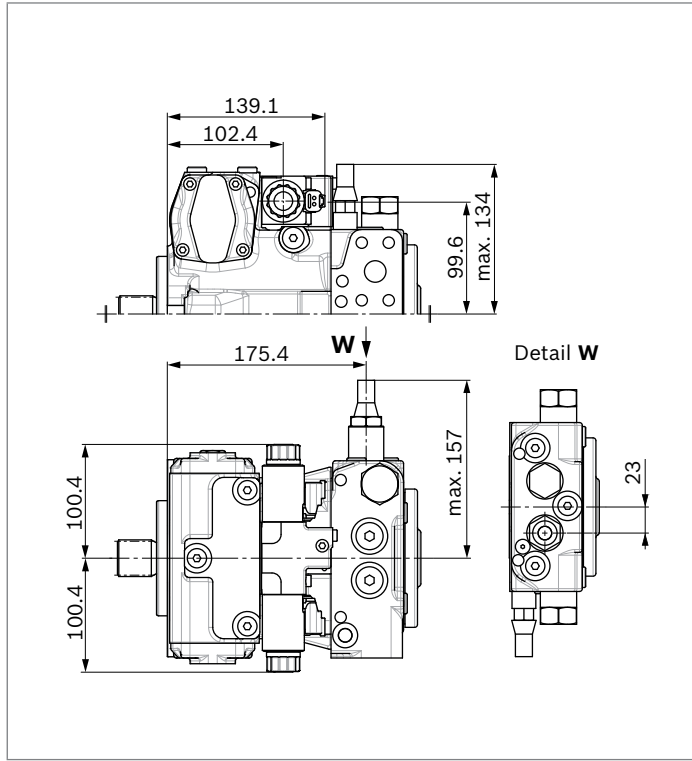

▼ **DA..3** – Mechanically adjustable with position lever

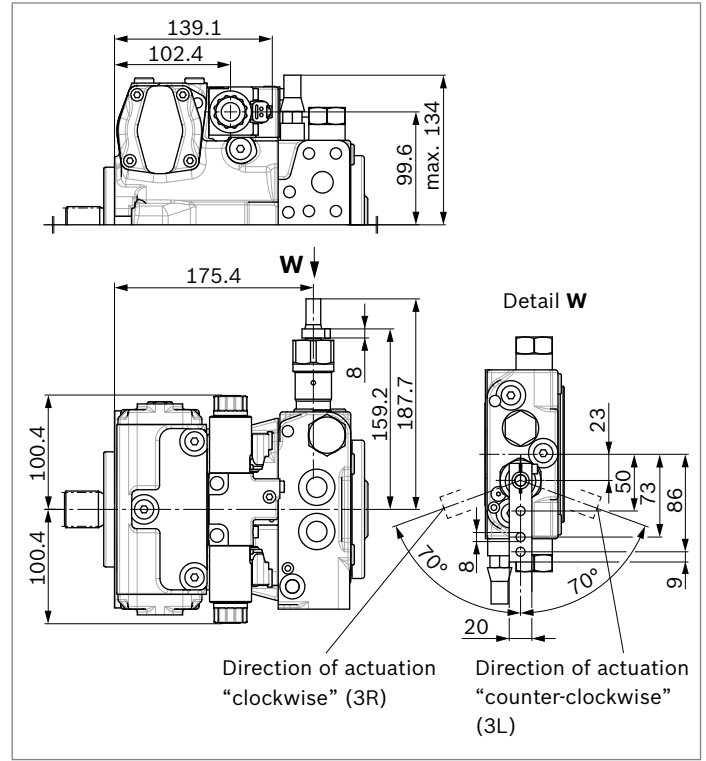

▼ **DA..7** – Fixed setting and ports for pilot control device

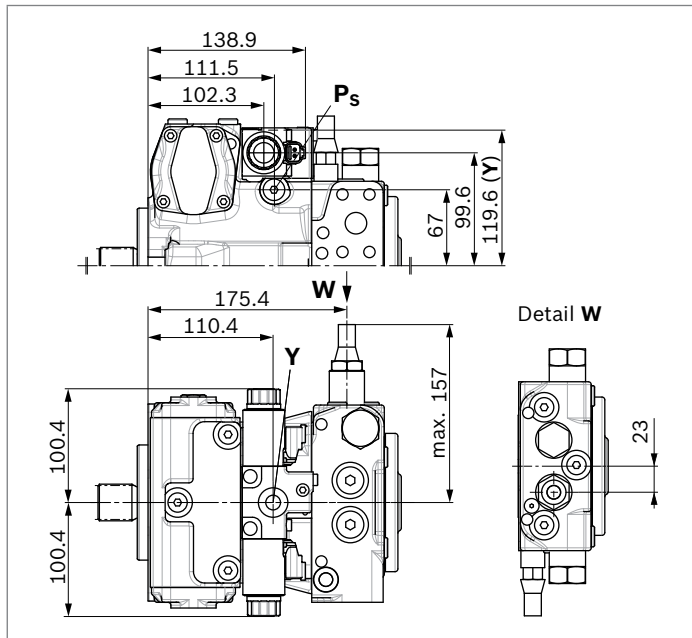

▼ **DA..8** – Fixed setting and inch valve mounted

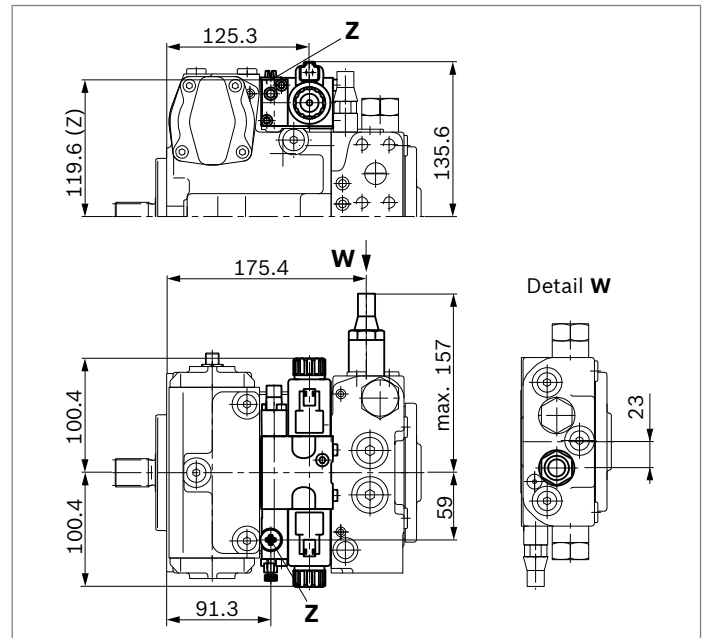

Dimensions, size 40

NV – Version without control module

Standard: SAE working port **A** and **B** top and bottom, suction port **S** bottom (02)

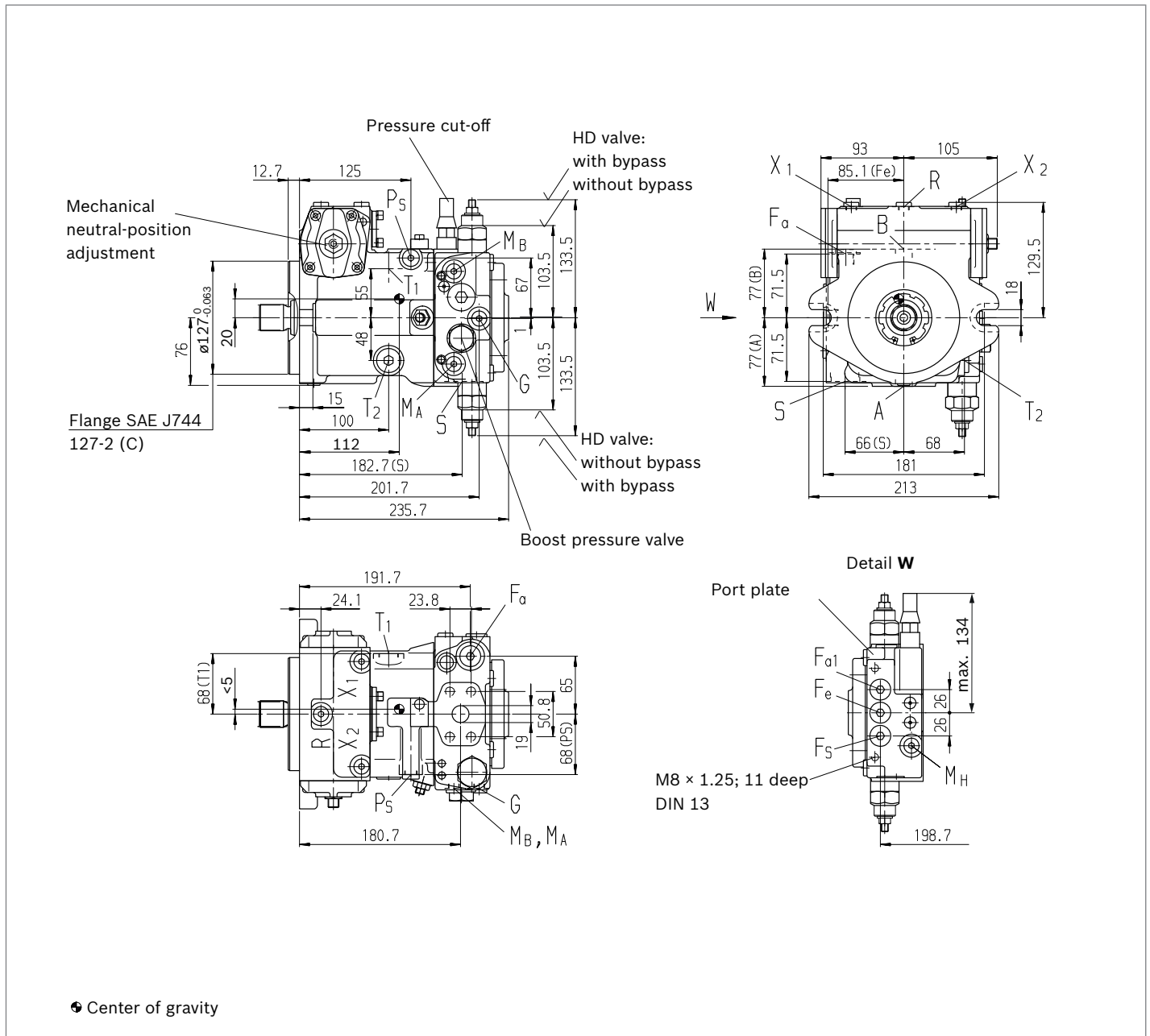

Notice

Option: SAE working port **A** and **B** top and bottom, suction port **S** top (03), port plate (02) rotated through 180°, installation drawing on request

▼ Splined shaft DIN 5480

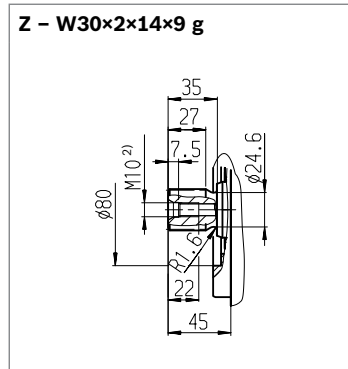

▼ Splined shaft DIN 5480

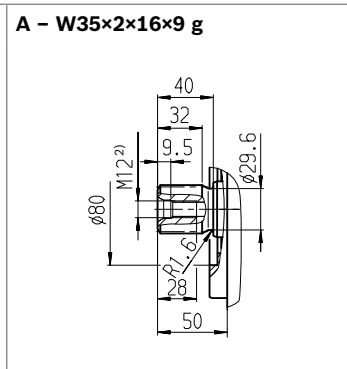

▼ Splined shaft ANSI B92.1a

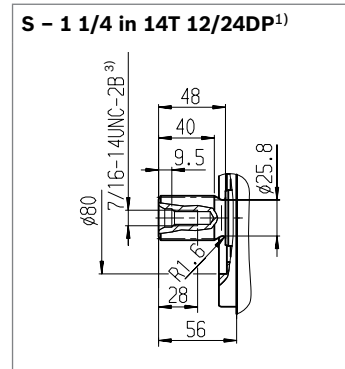

▼ Splined shaft ANSI B92.1a

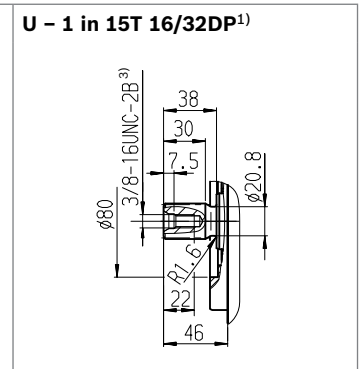

Ports	Standard	Size	p_{max} [bar] ⁴⁾	State ¹⁰⁾
A, B Working port Fastening thread	SAEJ518 ⁵⁾ DIN 13	3/4 in M10 × 1.5; 17 deep	450	O
S Suction port	DIN 3852 ⁸⁾	M33 × 2; 18 deep	5	O ⁶⁾
T₁ Drain port	DIN 3852 ⁸⁾	M22 × 1.5; 14 deep	3	O ⁷⁾
T₂ Drain port	DIN 3852 ⁸⁾	M22 × 1.5; 14 deep	3	X ⁷⁾
R Air bleed port	DIN 3852 ⁸⁾	M12 × 1.5; 12 deep	3	X
X₁, X₂ Control pressure port (upstream of orifice)	DIN 3852 ⁸⁾	M12 × 1.5; 12 deep	40	X
X₁, X₂ Control pressure port (upstream of orifice, DG only)	DIN 3852 ⁸⁾	M12 × 1.5; 12 deep	40	O
X₃, X₄ ⁹⁾ Stroking chamber pressure port	DIN 3852 ⁸⁾	M12 × 1.5; 12 deep	40	X
G Boost pressure port inlet	DIN 3852 ⁸⁾	M12 × 1.5; 12 deep	40	X
P_s Pilot pressure port	DIN 3852 ⁸⁾	M14 × 1.5; 12 deep	40	X
P_s Pilot pressure port (DA..7 only)	DIN 3852 ⁸⁾	M14 × 1.5; 12 deep	40	O
Y Pilot pressure port outlet (DA..7 only)	DIN 3852 ⁸⁾	M14 × 1.5; 12 deep	40	O
M_A, M_B Measuring port pressure A, B	DIN 3852 ⁸⁾	M12 × 1.5; 12 deep	450	X
M_H Measuring port, high pressure	DIN 3852 ⁸⁾	M12 × 1.5; 12 deep	450	X
F_a Boost pressure port inlet	DIN 3852 ⁸⁾	M18 × 1.5; 12 deep	40	X
F_{a1} Boost pressure port inlet (attachment filter)	DIN 3852 ⁸⁾	M18 × 1.5; 12 deep	40	X
F_e Boost pressure port outlet	DIN 3852 ⁸⁾	M18 × 1.5; 12 deep	40	X
F_s Line from filter to suction port (cold start)	DIN 3852 ⁸⁾	M18 × 1.5; 12 deep	40	X
Y₁, Y₂ Pilot pressure port (pilot signal HD only)	DIN 3852 ⁸⁾	M14 × 1.5; 12 deep	40	O
Z Pilot pressure port (inch signal DA..8 only)	DIN 3852 ⁸⁾	M10 × 1; 8 deep	40	X

1) Involute spline according to ANSI B92.1a, 30° pressure angle, flat root, side fit, tolerance class 5
 2) Center bore according to DIN 332 (thread according to DIN 13)
 3) Thread according to ASME B1.1
 4) Depending on the application, momentary pressure peaks can occur. Keep this in mind when selecting measuring devices and fittings.
 5) Only dimensions according to SAE J518, metric fastening thread is a deviation from the standard.

6) Plugged at external boost pressure supply.
 7) Depending on installation position, **T₁** or **T₂** must be connected (see also installation instructions on page 71).
 8) The countersink can be deeper than as specified in the standard.
 9) Optional, see page 62
 10) O = Must be connected (plugged when delivered)
 X = Plugged (in normal operation)

▼ **HD** – Proportional control, hydraulic, pilot-pressure related

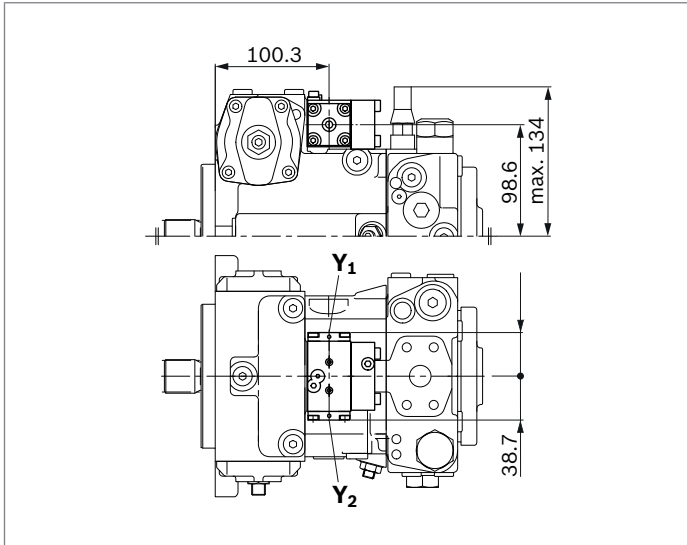

▼ **HW** – Proportional control, hydraulic, mechanical servo

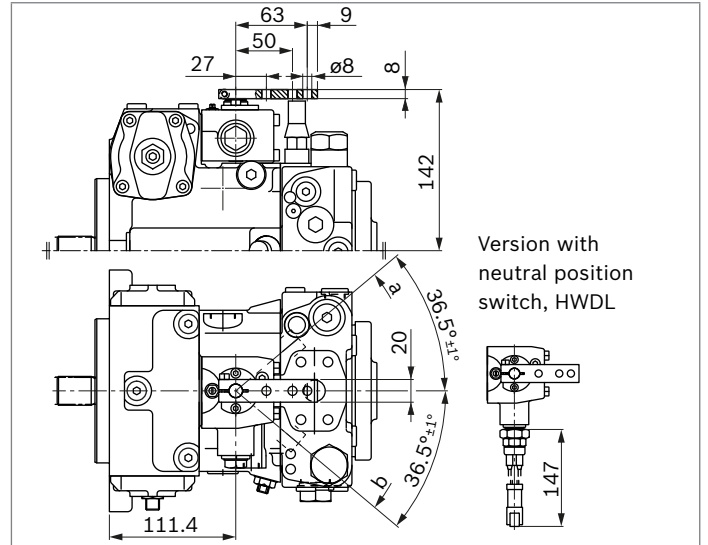

▼ **EP** – Proportional control, electric

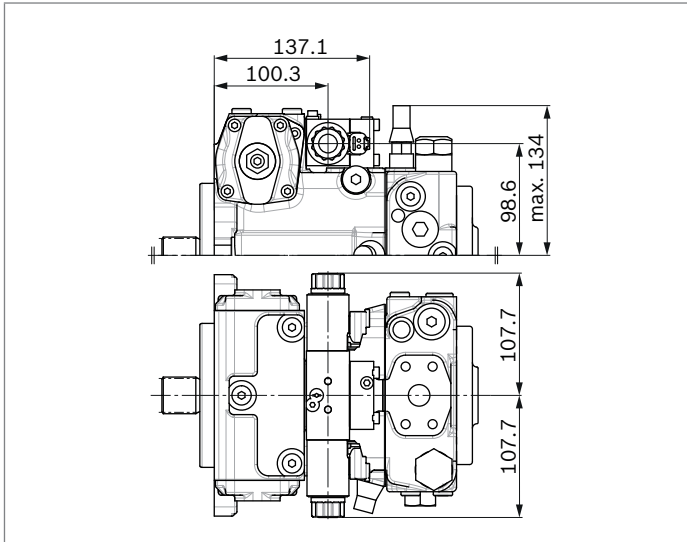

▼ **EZ** – Two-point control, electric

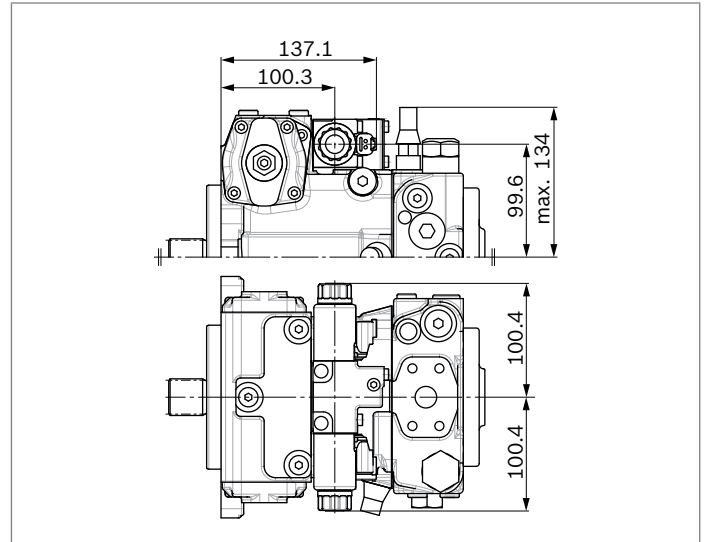

▼ **DG** – Hydraulic control, direct operated

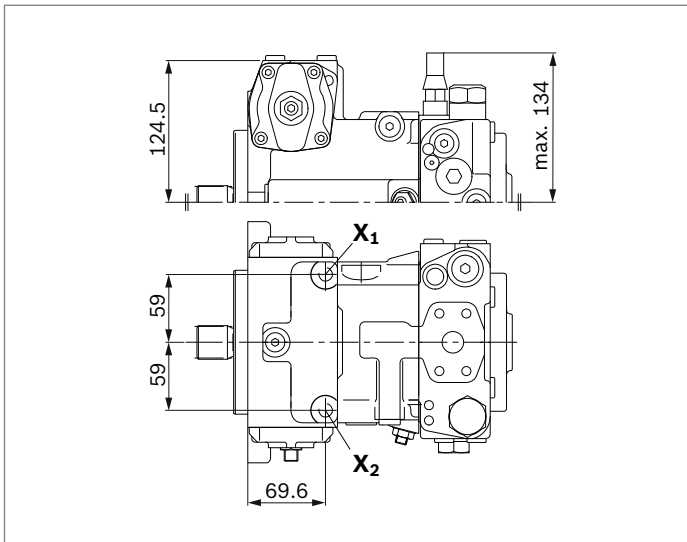

DA control valve

▼ **DA..2** – Fixed setting

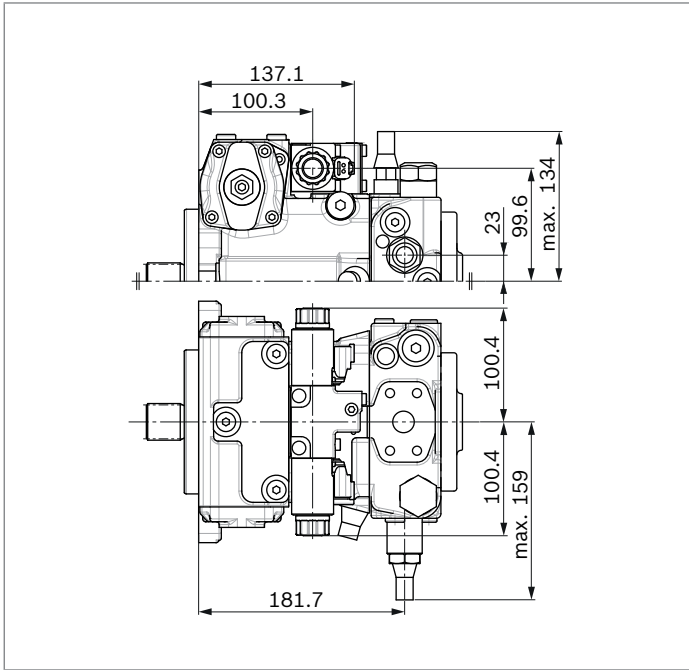

▼ **DA..3** – Mechanically adjustable with position lever

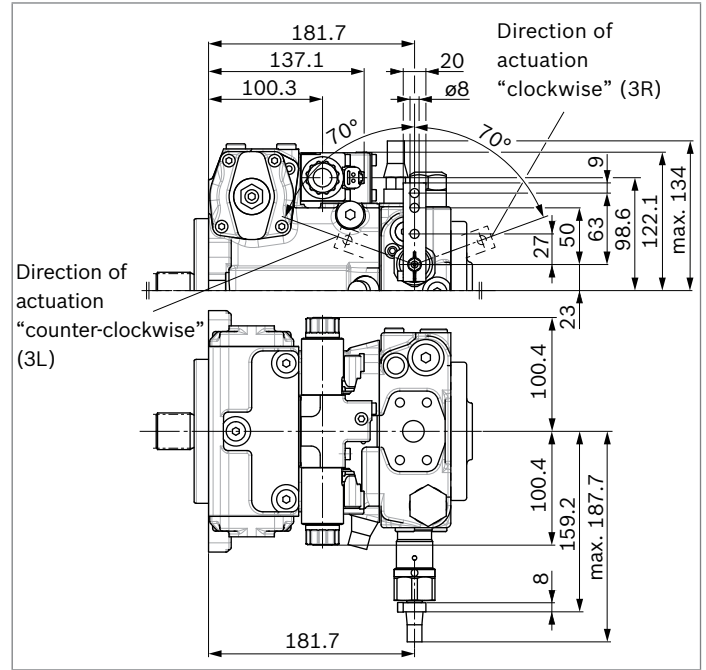

▼ **DA..7** – Fixed setting and ports for pilot control device

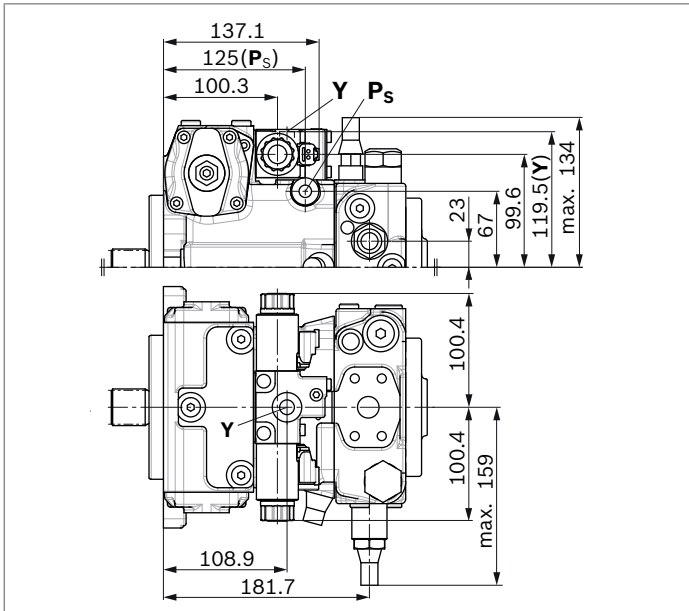

▼ **DA..8** – Fixed setting and inch valve mounted

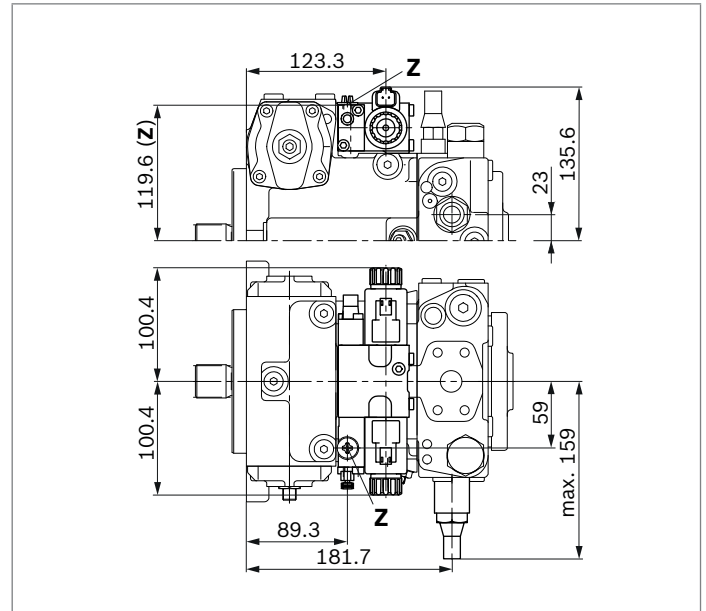

Dimensions, size 56

NV – Version without control module

Standard: SAE working port **A** and **B** top and bottom, suction port **S** bottom (02)

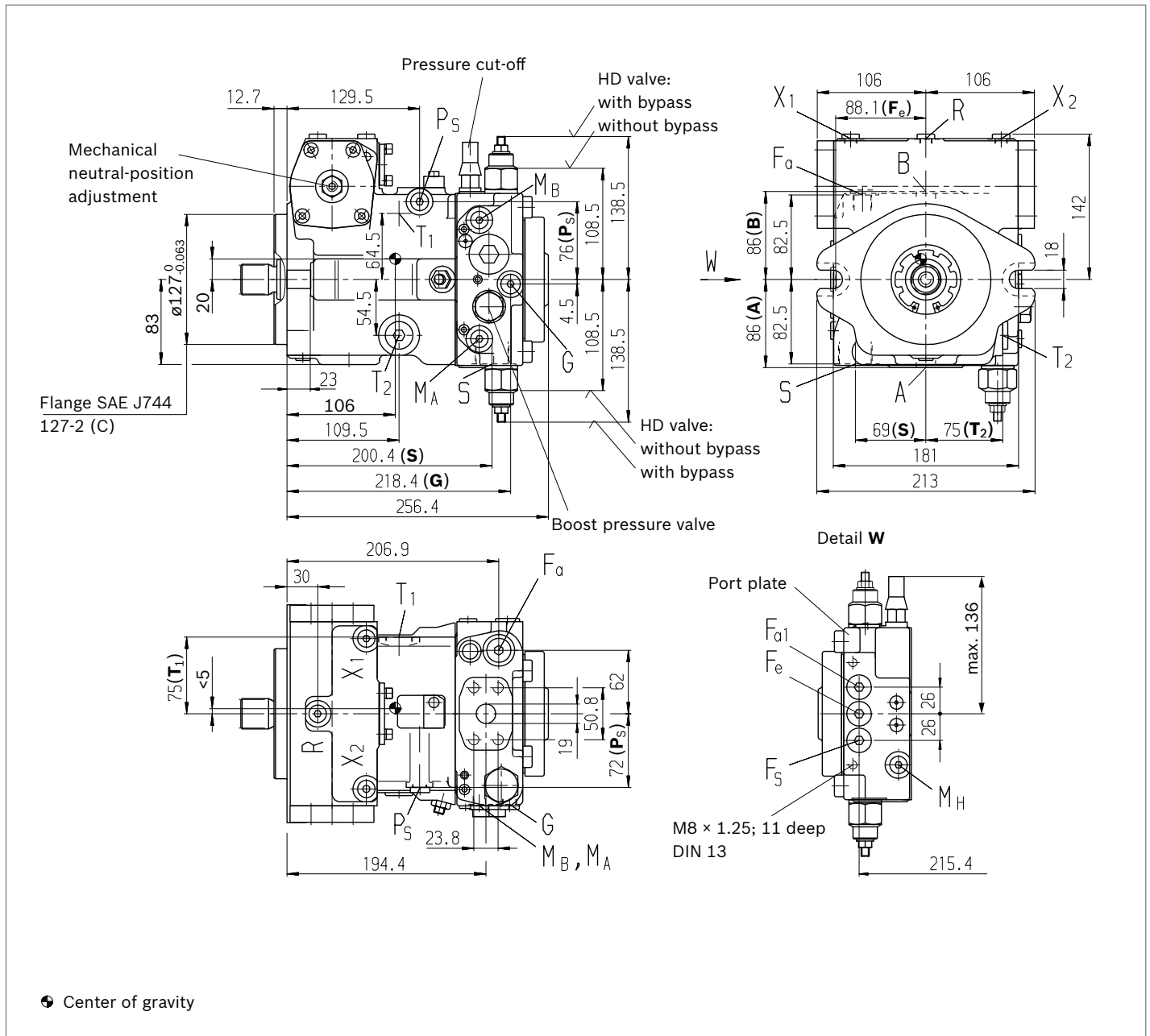

Notice
 Option: SAE working port **A** and **B** top and bottom, suction port **S** top (03), port plate (02) rotated through 180°, installation drawing on request

NV – Version without control module

Option: SAE working port **A** and **B**, same side left, suction port **S** top (13)

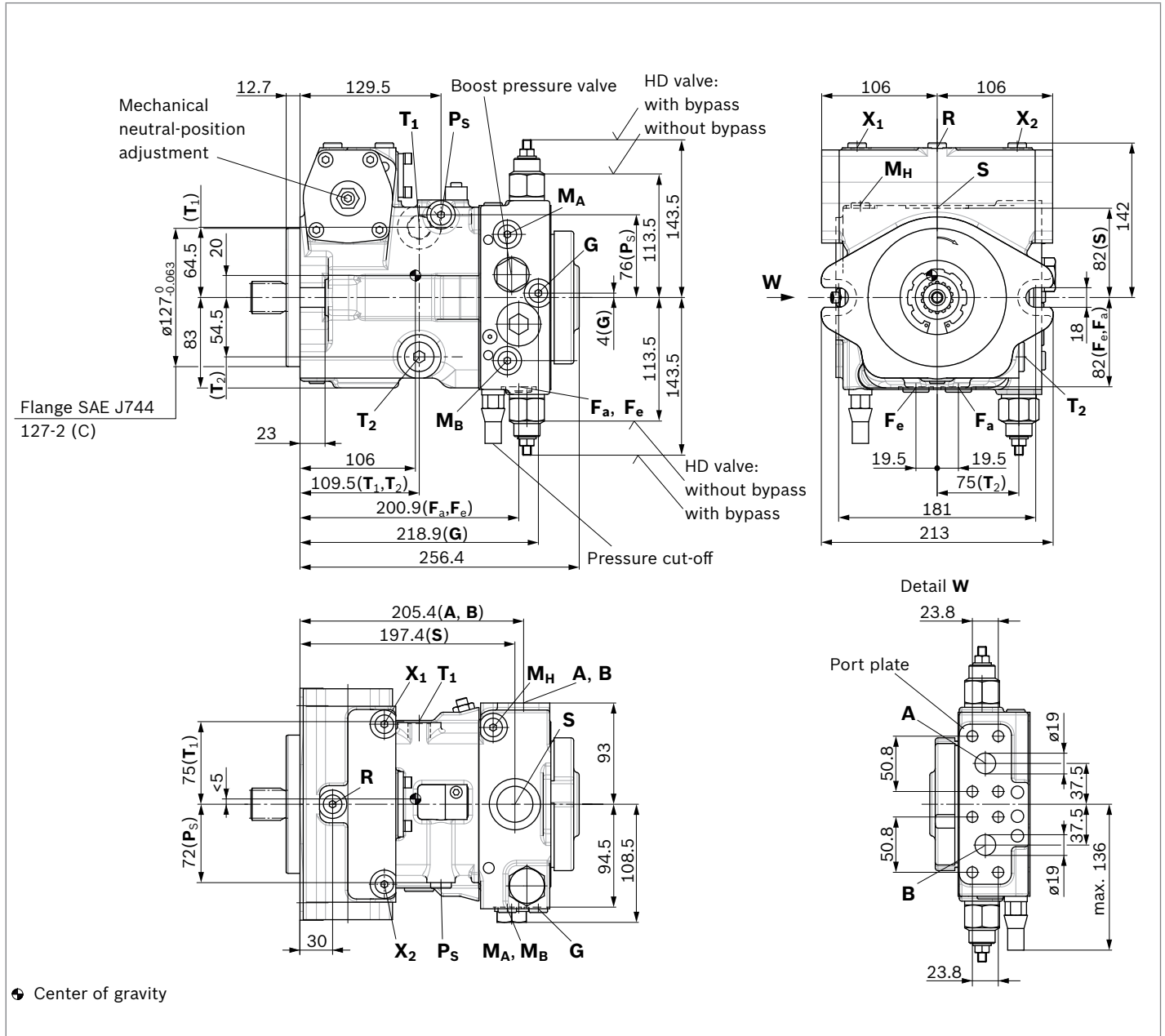

▼ Splined shaft DIN 5480

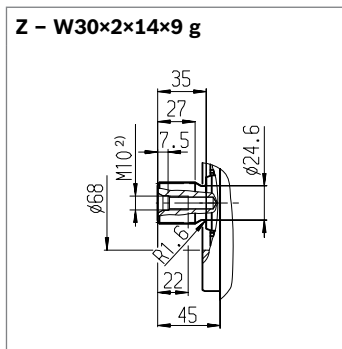

▼ Splined shaft DIN 5480

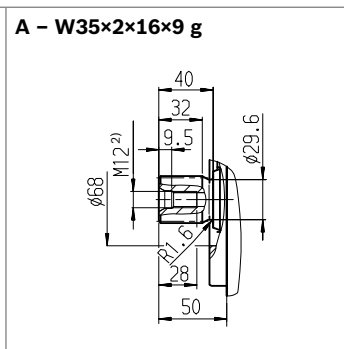

▼ Splined shaft ANSI B92.1a

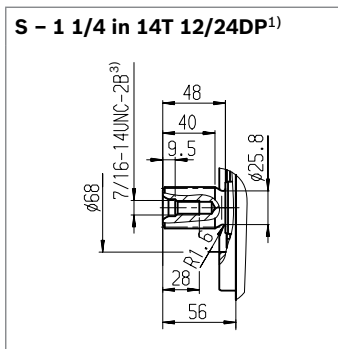

▼ Splined shaft ANSI B92.1a

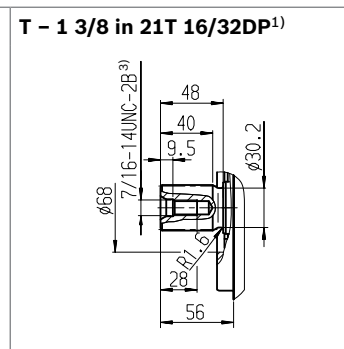

Ports	Standard	Size	p_{\max} [bar] ⁴⁾	State ¹⁰⁾
A, B	SAEJ518 ⁵⁾	3/4 in	450	O
	DIN 13	M10 × 1.5; 17 deep		
S	DIN 3852 ⁸⁾	M33 × 2; 18 deep	5	O ⁶⁾
T₁	DIN 3852 ⁸⁾	M22 × 1.5; 14 deep	3	O ⁷⁾
T₂	DIN 3852 ⁸⁾	M22 × 1.5; 14 deep	3	X ⁷⁾
R	DIN 3852 ⁸⁾	M12 × 1.5; 12 deep	3	X
X₁, X₂	DIN 3852 ⁸⁾	M12 × 1.5; 12 deep	40	X
X₁, X₂	DIN 3852 ⁸⁾	M12 × 1.5; 12 deep	40	O
X₃, X₄ ⁹⁾	DIN 3852 ⁸⁾	M12 × 1.5; 12 deep	40	X
G	DIN 3852 ⁸⁾	M14 × 1.5; 12 deep	40	X
P_S	DIN 3852 ⁸⁾	M14 × 1.5; 12 deep	40	X
P_S	DIN 3852 ⁸⁾	M14 × 1.5; 12 deep	40	O
Y	DIN 3852 ⁸⁾	M14 × 1.5; 12 deep	40	O
M_A, M_B	DIN 3852 ⁸⁾	M12 × 1.5; 12 deep	450	X
M_H	DIN 3852 ⁸⁾	M12 × 1.5; 12 deep	450	X
F_a	DIN 3852 ⁸⁾	M18 × 1.5; 12 deep	40	X
F_{a1}	DIN 3852 ⁸⁾	M18 × 1.5; 12 deep	40	X
F_e	DIN 3852 ⁸⁾	M18 × 1.5; 12 deep	40	X
F_S	DIN 3852 ⁸⁾	M18 × 1.5; 12 deep	40	X
Y₁, Y₂	DIN 3852 ⁸⁾	M14 × 1.5; 12 deep	40	O
Z	DIN 3852 ⁸⁾	M10 × 1; 8 deep	40	X

- 1) Involute spline according to ANSI B92.1a, 30° pressure angle, flat root, side fit, tolerance class 5
- 2) Center bore according to DIN 332 (thread according to DIN 13)
- 3) Thread according to ASME B1.1
- 4) Depending on the application, momentary pressure peaks can occur. Keep this in mind when selecting measuring devices and fittings.
- 5) Only dimensions according to SAE J518, metric fastening thread is a deviation from the standard.

- 6) Plugged at external boost pressure supply.
- 7) Depending on installation position, **T₁** or **T₂** must be connected (see also installation instructions on page 71).
- 8) The countersink can be deeper than as specified in the standard.
- 9) Optional, see page 62
- 10) O = Must be connected (plugged when delivered)
X = Plugged (in normal operation)

▼ **HD** – Proportional control, hydraulic, pilot-pressure related

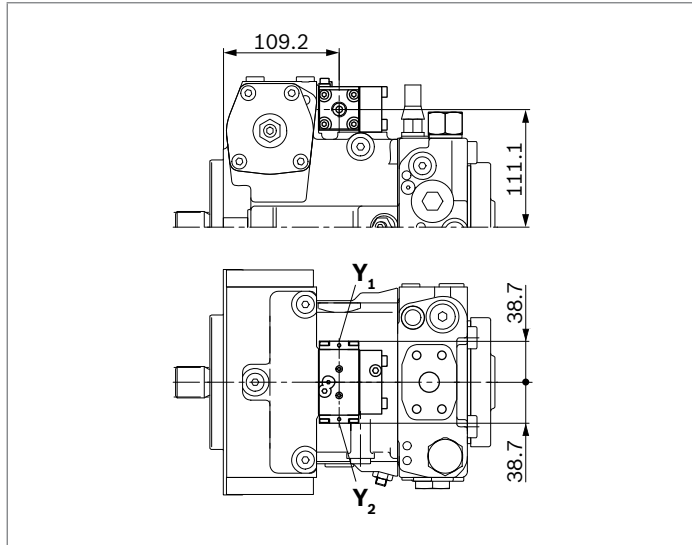

▼ **HW** – Proportional control, hydraulic, mechanical servo

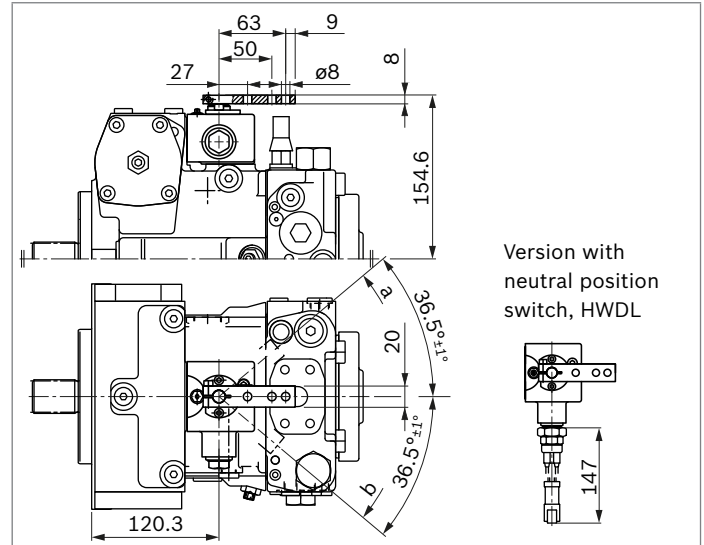

▼ **EP** – Proportional control, electric

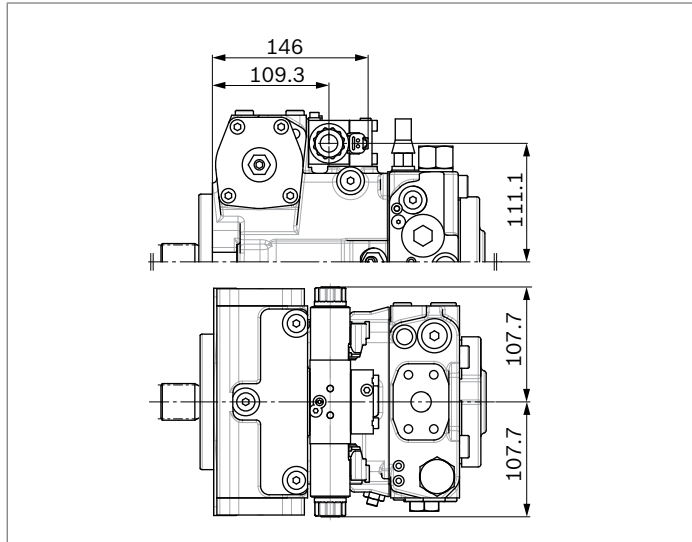

▼ **EZ** – Two-point control, electric

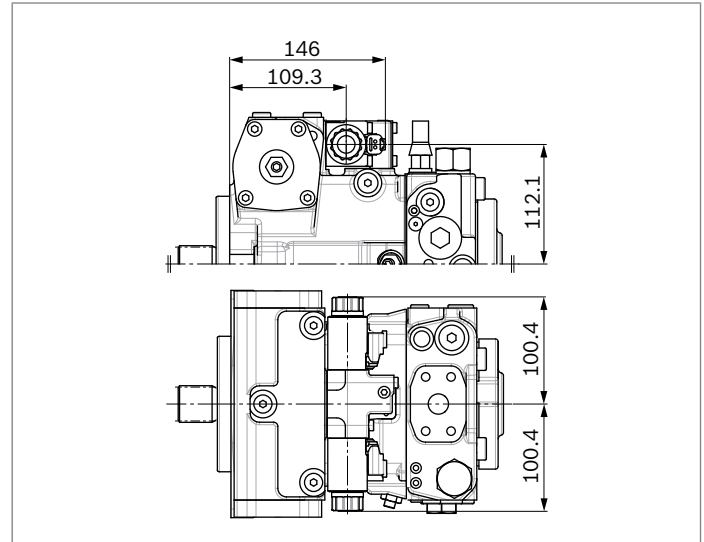

▼ **DG** – Hydraulic control, direct operated

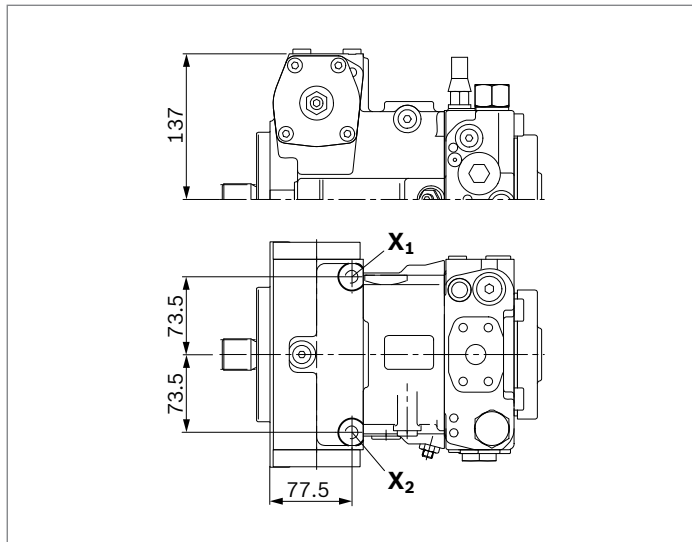

DA control valve

▼ **DA..2** – Fixed setting

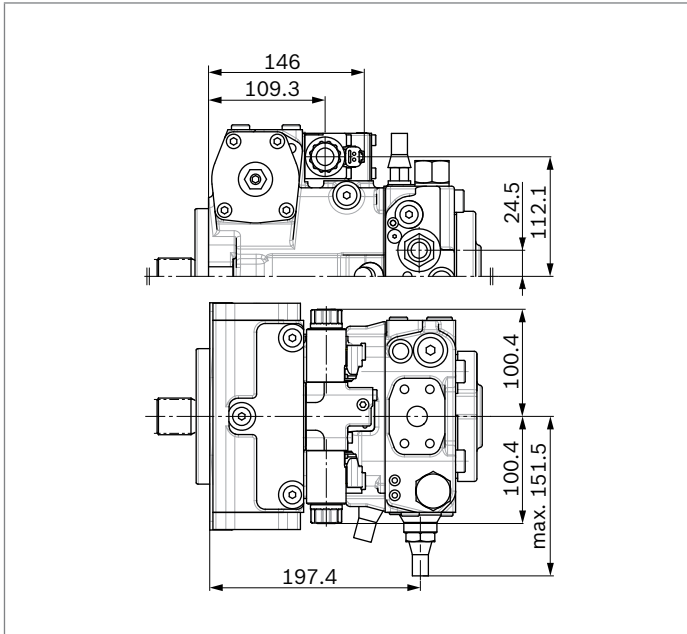

▼ **DA..3** – Mechanically adjustable with position lever

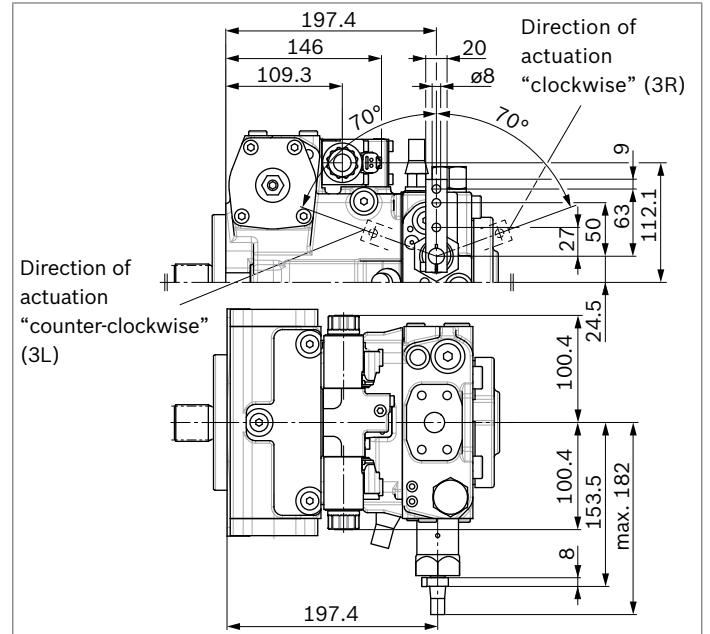

▼ **DA..7** – Fixed setting and ports for pilot control device

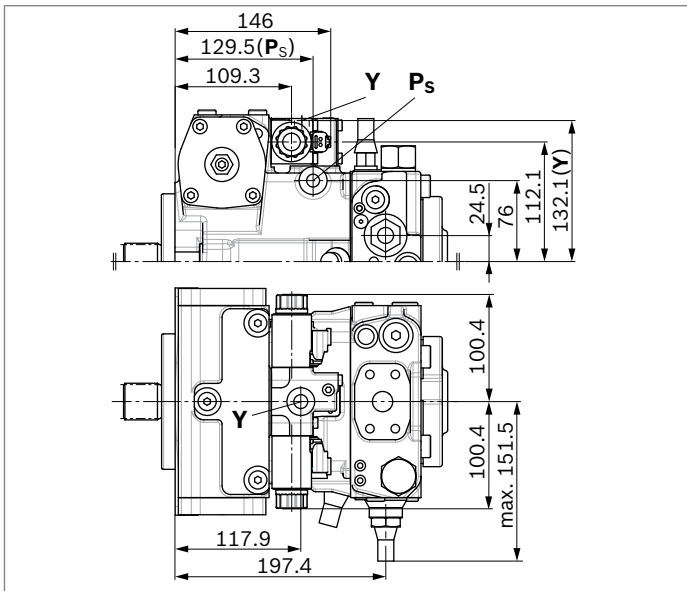

▼ **DA..8** – Fixed setting and inch valve mounted

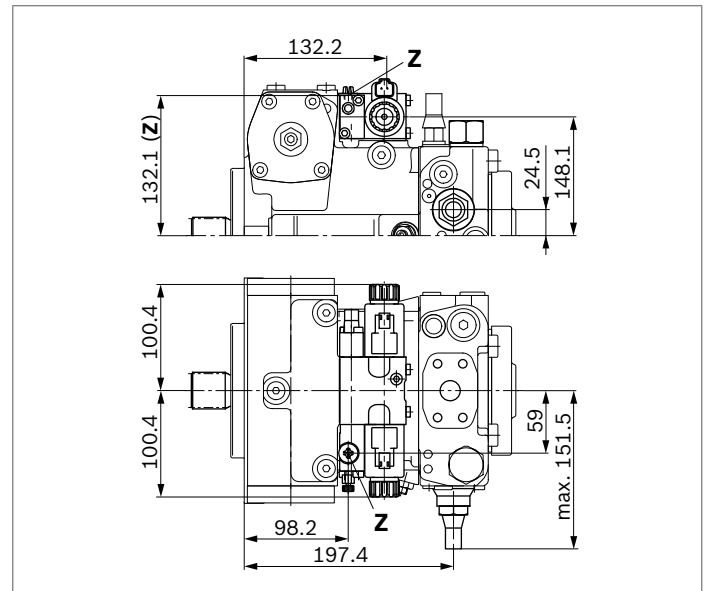

Dimensions, size 71

NV – Version without control module

Standard: SAE working port **A** and **B** top and bottom, suction port **S** bottom (02)

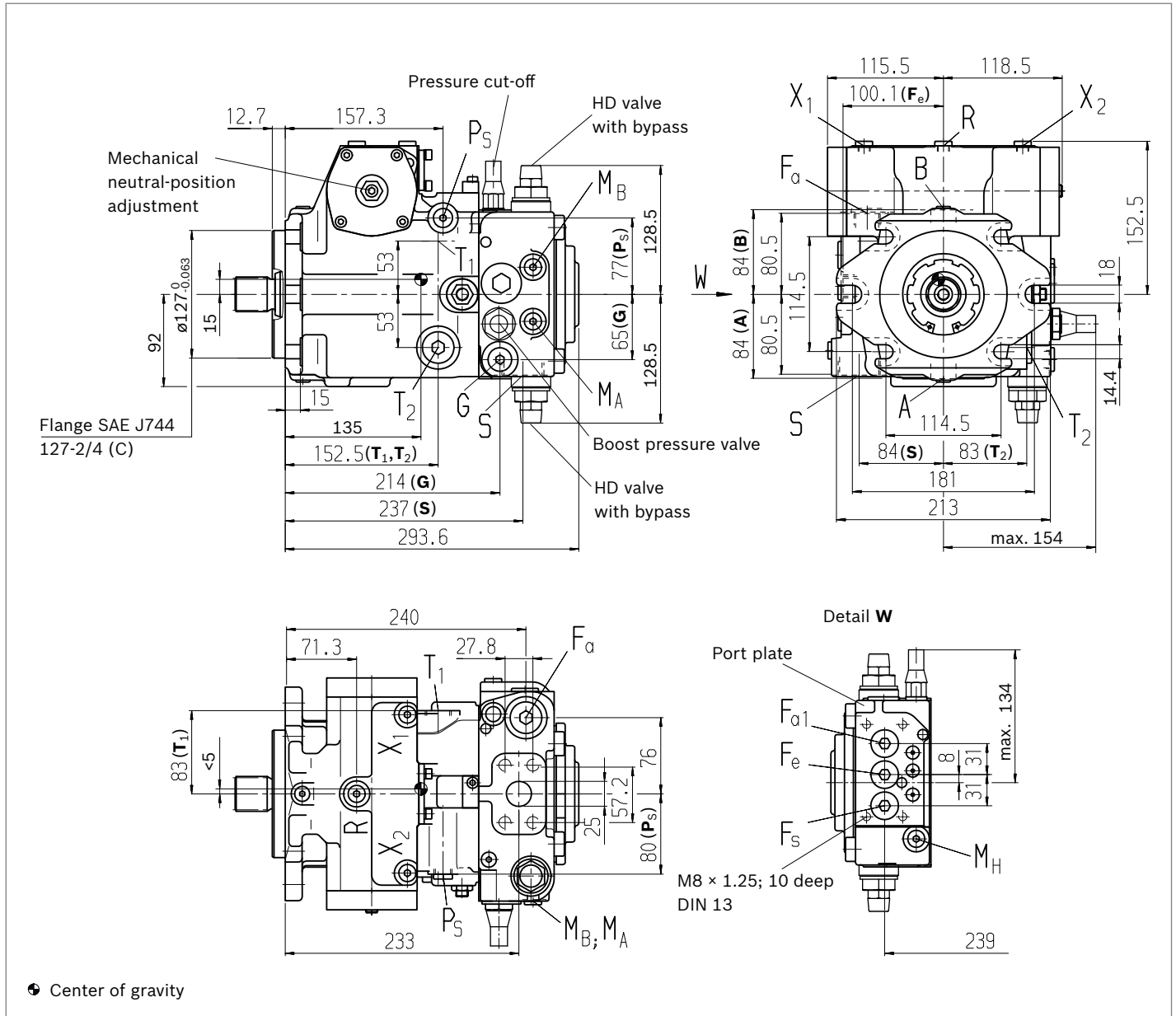

Notice

Option: SAE working port **A** and **B** top and bottom, suction port **S** top (03). Port plate (02) rotated through 180°, installation drawing on request

NV – Version without control module

Standard: SAE working port **A** and **B**, same side left, suction port **S** bottom (10)

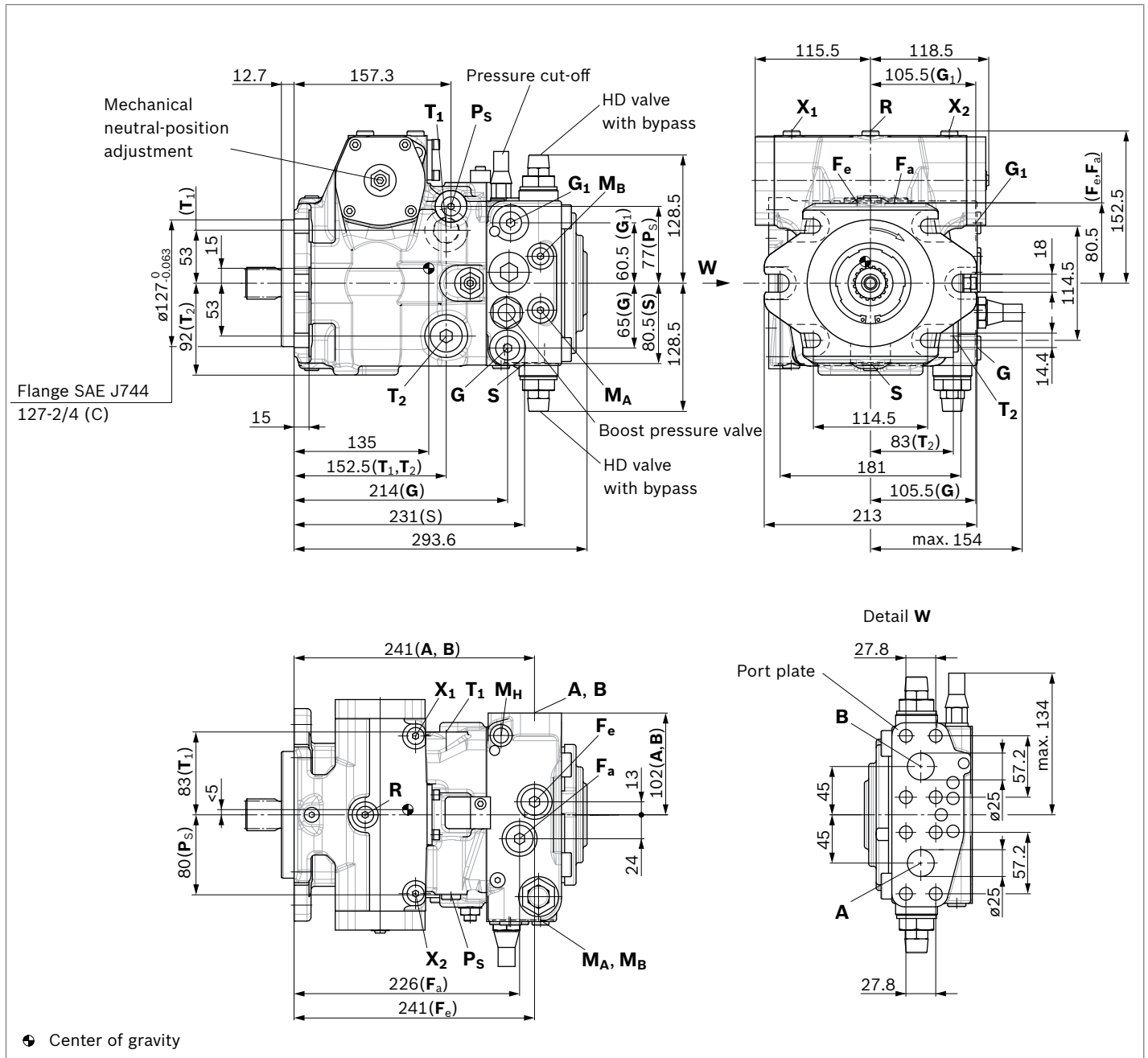

Notice

Option: SAE working port **A** and **B**, same side right, suction port **S** top (13), installation drawing on request

▼ Splined shaft DIN 5480

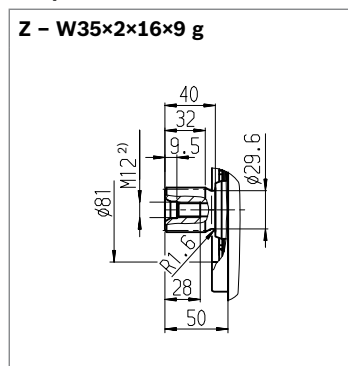

▼ Splined shaft DIN 5480

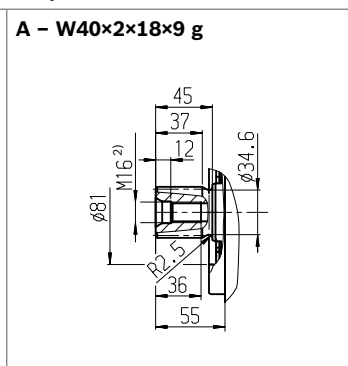

▼ Splined shaft ANSI B92.1a

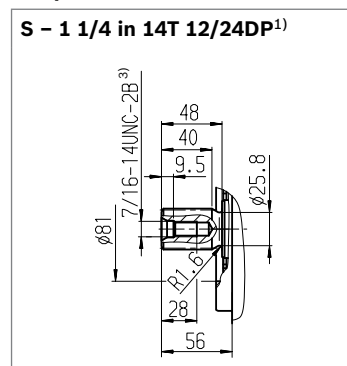

▼ Splined shaft ANSI B92.1a

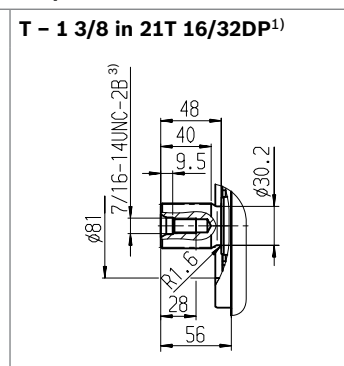

Ports		Standard	Size	p_{max} [bar] ⁽⁴⁾	State ⁽¹⁰⁾
A, B	Working port Fastening thread	SAEJ518 ⁽⁵⁾ DIN 13	1 in M12 × 1.75; 17 deep	450	O
S	Suction port	DIN 3852 ⁽⁸⁾	M42 × 2; 20 deep	5	O ⁽⁶⁾
T₁	Drain port	DIN 3852 ⁽⁸⁾	M26 × 1.5; 16 deep	3	O ⁽⁷⁾
T₂	Drain port	DIN 3852 ⁽⁸⁾	M26 × 1.5; 16 deep	3	X ⁽⁷⁾
R	Air bleed port	DIN 3852 ⁽⁸⁾	M12 × 1.5; 12 deep	3	X
X₁, X₂	Control pressure port (upstream of orifice)	DIN 3852 ⁽⁸⁾	M12 × 1.5; 12 deep	40	X
X₁, X₂	Control pressure port (upstream of orifice, DG only)	DIN 3852 ⁽⁸⁾	M12 × 1.5; 12 deep	40	O
X₃, X₄⁽⁹⁾	Stroking chamber pressure port	DIN 3852 ⁽⁸⁾	M12 × 1.5; 12 deep	40	X
G	Boost pressure port inlet	DIN 3852 ⁽⁸⁾	M18 × 1.5; 12 deep	40	X
P_S	Pilot pressure port	DIN 3852 ⁽⁸⁾	M14 × 1.5; 12 deep	40	X
P_S	Pilot pressure port (DA..7 only)	DIN 3852 ⁽⁸⁾	M14 × 1.5; 12 deep	40	O
Y	Pilot pressure port outlet (DA..7 only)	DIN 3852 ⁽⁸⁾	M14 × 1.5; 12 deep	40	O
M_A, M_B	Measuring port pressure A, B	DIN 3852 ⁽⁸⁾	M12 × 1.5; 12 deep	450	X
M_H	Measuring port, high pressure	DIN 3852 ⁽⁸⁾	M12 × 1.5; 12 deep	450	X
F_a	Boost pressure port inlet	DIN 3852 ⁽⁸⁾	M26 × 1.5; 16 deep	40	X
F_{a1}	Boost pressure port inlet (attachment filter)	DIN 3852 ⁽⁸⁾	M22 × 1.5; 14 deep	40	X
F_e	Boost pressure port outlet	DIN 3852 ⁽⁸⁾	M22 × 1.5; 14 deep	40	X
F_S	Line from filter to suction port (cold start)	DIN 3852 ⁽⁸⁾	M22 × 1.5; 14 deep	40	X
Y₁, Y₂	Pilot pressure port (pilot signal HD only)	DIN 3852 ⁽⁸⁾	M14 × 1.5; 8 deep	40	O
Z	Pilot pressure port (inch signal DA..8 only)	DIN 3852 ⁽⁸⁾	M10 × 1; 12 deep	40	X

- 1) Involute spline according to ANSI B92.1a, 30° pressure angle, flat root, side fit, tolerance class 5
- 2) Center bore according to DIN 332 (thread according to DIN 13)
- 3) Thread according to ASME B1.1
- 4) Depending on the application, momentary pressure peaks can occur. Keep this in mind when selecting measuring devices and fittings.
- 5) Only dimensions according to SAE J518, metric fastening thread is a deviation from the standard.

- 6) Plugged at external boost pressure supply.
- 7) Depending on installation position, **T₁** or **T₂** must be connected (see also installation instructions on page 71).
- 8) The countersink can be deeper than as specified in the standard.
- 9) Optional, see page 62
- 10) O = Must be connected (plugged when delivered)
X = Plugged (in normal operation)

▼ **HD** – Proportional control, hydraulic, pilot-pressure related

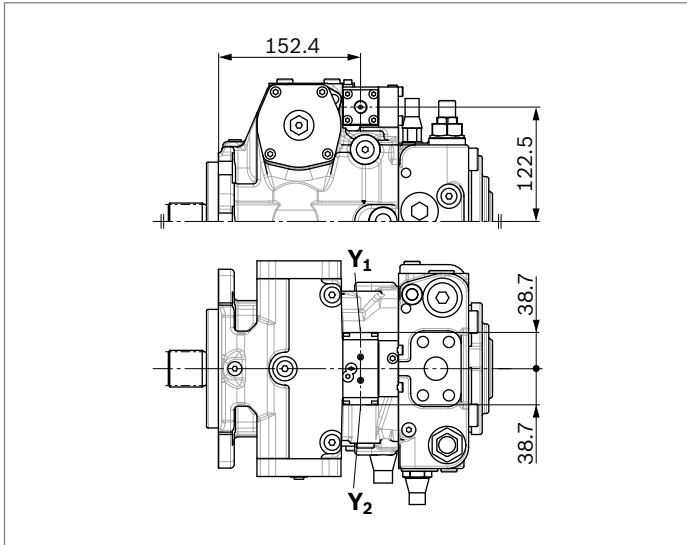

▼ **HW** – Proportional control, hydraulic, mechanical servo

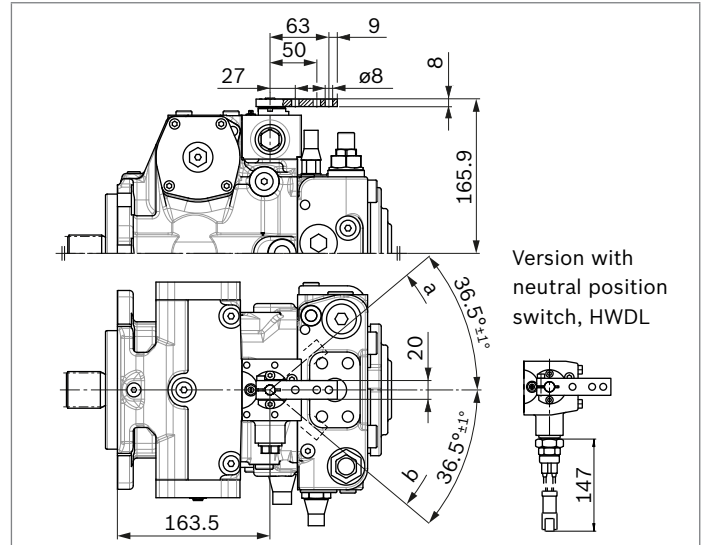

▼ **EP** – Proportional control, electric

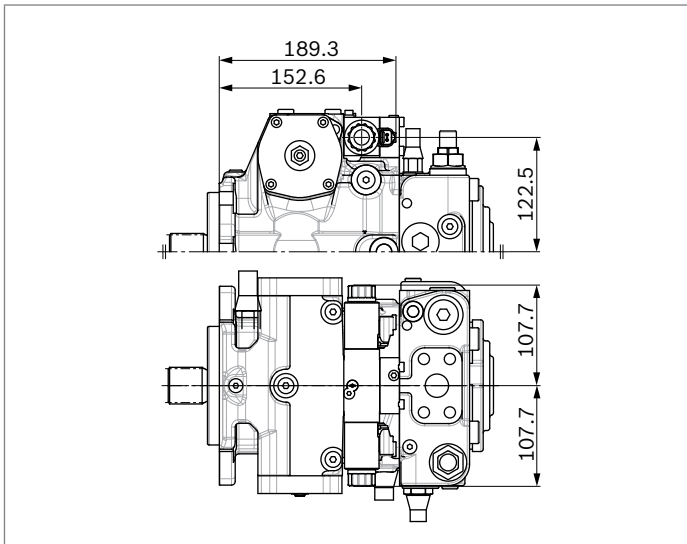

▼ **EZ** – Two-point control, electric

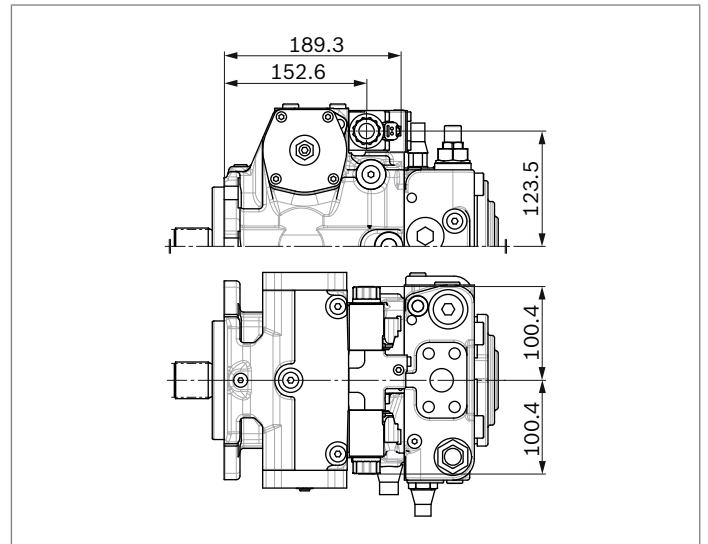

▼ **DG** – Hydraulic control, direct operated

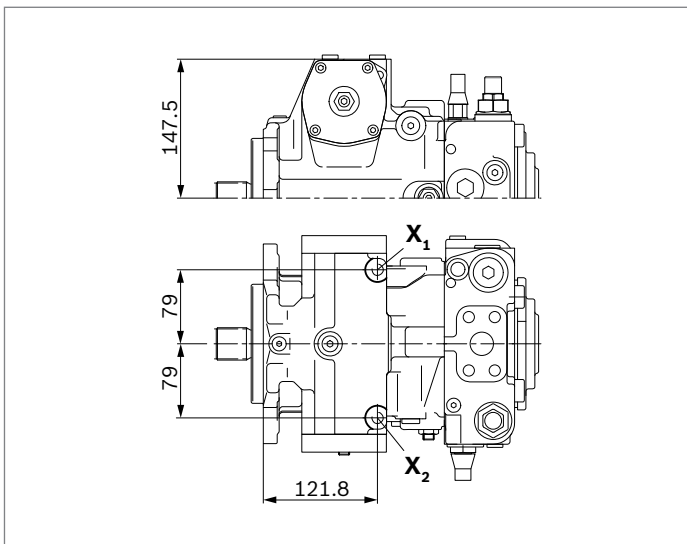

DA control valve

▼ **DA..2** – Fixed setting

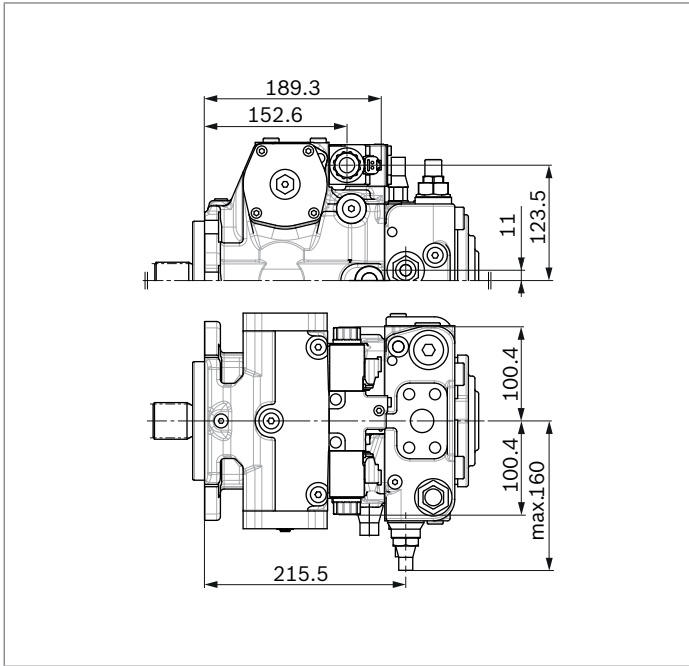

▼ **DA..3** – Mechanically adjustable with position lever

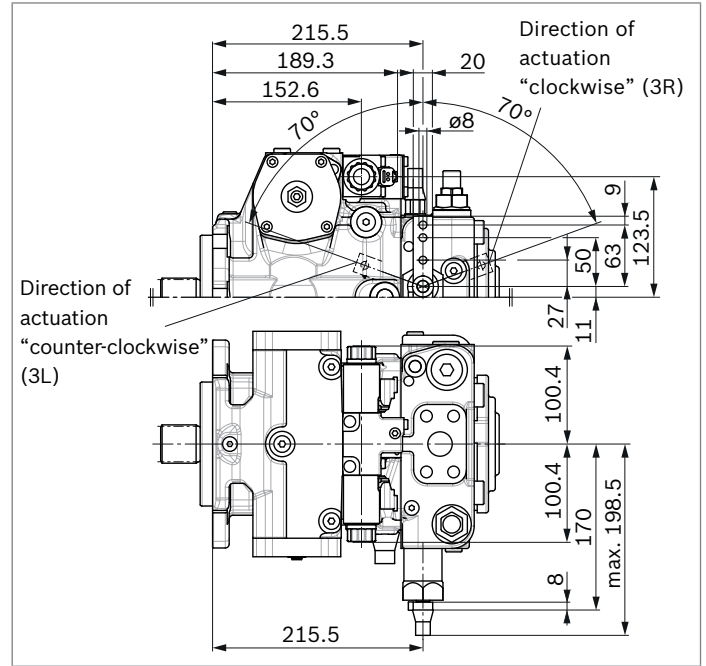

▼ **DA..7** – Fixed setting and ports for pilot control device

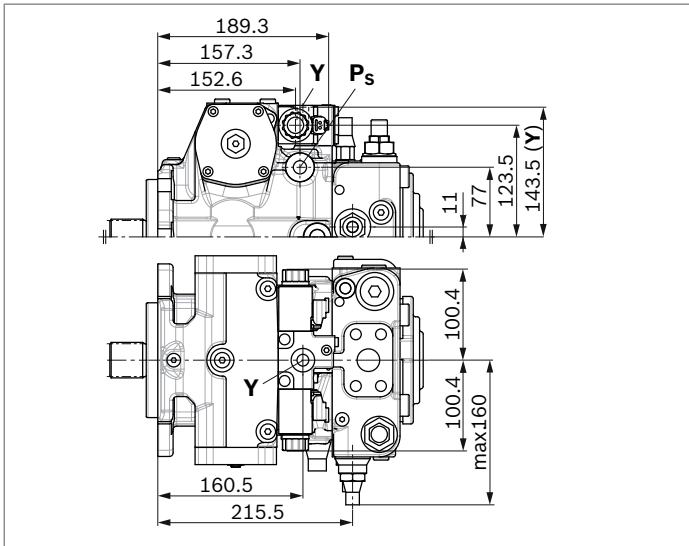

▼ **DA..8** – Fixed setting and inch valve mounted

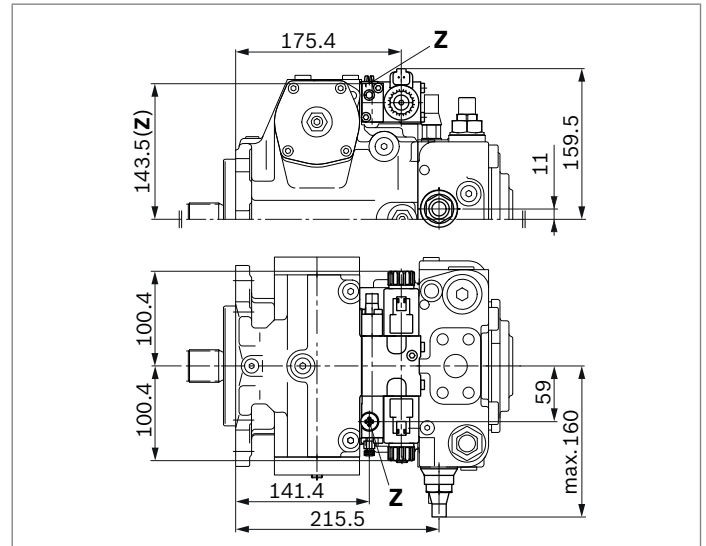

Dimensions, size 90

NV – Version without control module

Standard: SAE working port **A** and **B** top and bottom, suction port **S** bottom (02)

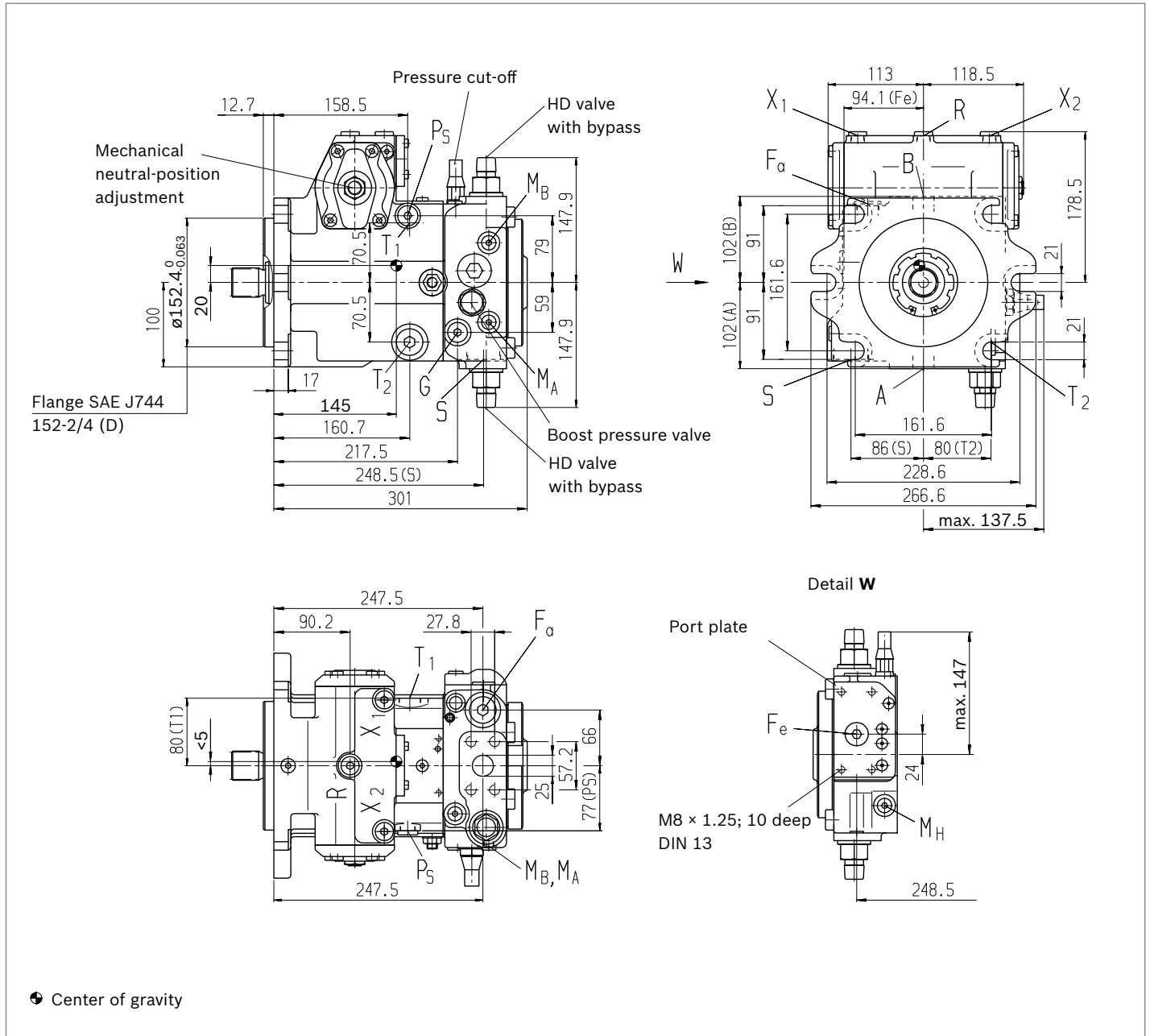

Notice
 Option: SAE working port **A** and **B** top and bottom, suction port **S** top (03). Port plate (02) rotated through 180°, installation drawing on request

▼ Splined shaft DIN 5480

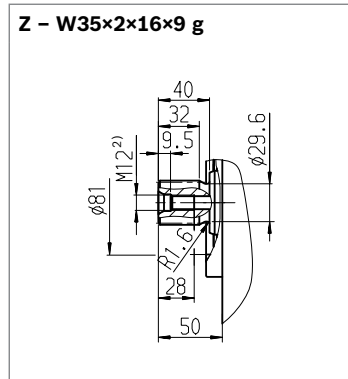

▼ Splined shaft DIN 5480

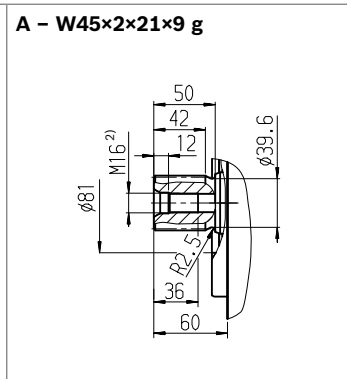

▼ Splined shaft ANSI B92.1a

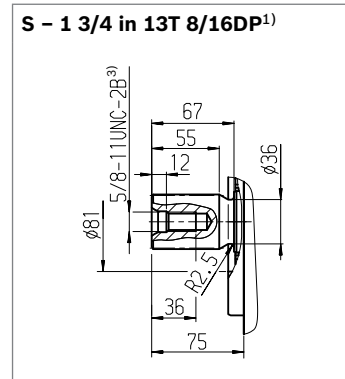

▼ Splined shaft ANSI B92.1a

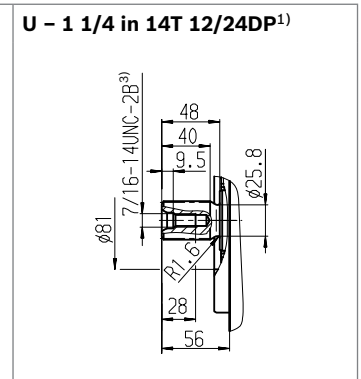

Ports	Standard	Size	p_{max} [bar] ⁴⁾	State ¹⁰⁾	
A, B	Working port	SAEJ518 ⁵⁾	1 in	450	O
	Fastening thread	DIN 13	M12 × 1.75; 17 deep		
S	Suction port	DIN 3852 ⁸⁾	M42 × 2; 20 deep	5	O ⁶⁾
T₁	Drain port	DIN 3852 ⁸⁾	M26 × 1.5; 16 deep	3	O ⁷⁾
T₂	Drain port	DIN 3852 ⁸⁾	M26 × 1.5; 16 deep	3	X ⁷⁾
R	Air bleed port	DIN 3852 ⁸⁾	M16 × 1.5; 12 deep	3	X
X₁, X₂	Control pressure port (upstream of orifice)	DIN 3852 ⁸⁾	M16 × 1.5; 12 deep	40	X
X₁, X₂	Control pressure port (upstream of orifice, DG only)	DIN 3852 ⁸⁾	M16 × 1.5; 12 deep	40	O
X₃, X₄ ⁹⁾	Stroking chamber pressure port	DIN 3852 ⁸⁾	M12 × 1.5; 12 deep	40	X
G	Boost pressure port inlet	DIN 3852 ⁸⁾	M18 × 1.5; 12 deep	40	X
P_s	Pilot pressure port	DIN 3852 ⁸⁾	M18 × 1.5; 12 deep	40	X
P_s	Pilot pressure port (DA..7 only)	DIN 3852 ⁸⁾	M18 × 1.5; 12 deep	40	O
Y	Pilot pressure port outlet (DA..7 only)	DIN 3852 ⁸⁾	M18 × 1.5; 12 deep	40	O
M_A, M_B	Measuring port pressure A, B	DIN 3852 ⁸⁾	M12 × 1.5; 12 deep	450	X
M_H	Measuring port, high pressure	DIN 3852 ⁸⁾	M12 × 1.5; 12 deep	450	X
F_a	Boost pressure port inlet	DIN 3852 ⁸⁾	M26 × 1.5; 16 deep	40	X
F_{a1}	Boost pressure port inlet (attachment filter)	DIN 3852 ⁸⁾	M22 × 1.5; 14 deep	40	X
F_e	Boost pressure port outlet	DIN 3852 ⁸⁾	M22 × 1.5; 14 deep	40	X
F_s	Line from filter to suction port (cold start)	DIN 3852 ⁸⁾	M22 × 1.5; 14 deep	40	X
Y₁, Y₂	Pilot pressure port (pilot signal HD only)	DIN 3852 ⁸⁾	M14 × 1.5; 12 deep	40	O
Z	Pilot pressure port (inch signal DA..8 only)	DIN 3852 ⁸⁾	M10 × 1; 8 deep	40	X

- 1) Involute spline according to ANSI B92.1a, 30° pressure angle, flat root, side fit, tolerance class 5
- 2) Center bore according to DIN 332 (thread according to DIN 13)
- 3) Thread according to ASME B1.1
- 4) Depending on the application, momentary pressure peaks can occur. Keep this in mind when selecting measuring devices and fittings.
- 5) Only dimensions according to SAE J518, metric fastening thread is a deviation from the standard.

- 6) Plugged at external boost pressure supply.
- 7) Depending on installation position, **T₁** or **T₂** must be connected (see also installation instructions on page 71).
- 8) The countersink can be deeper than as specified in the standard.
- 9) Optional, see page 62
- 10) O = Must be connected (plugged when delivered)
X = Plugged (in normal operation)

▼ **HD** – Proportional control, hydraulic, pilot-pressure related

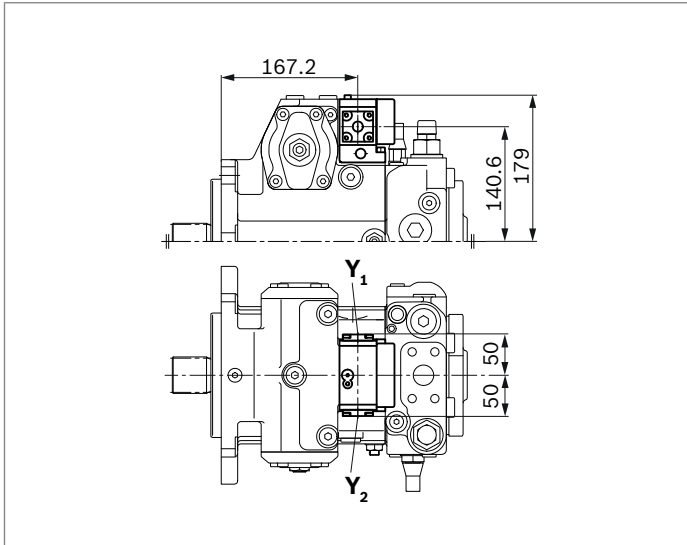

▼ **HW** – Proportional control, hydraulic, mechanical servo

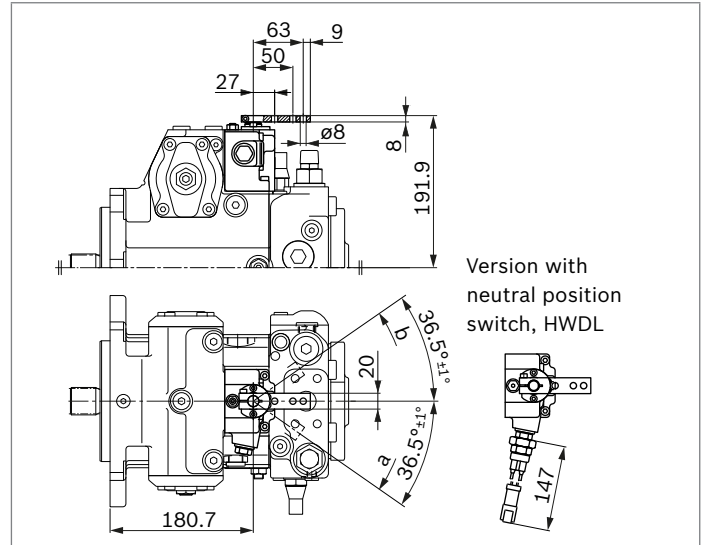

▼ **EP** – Proportional control, electric

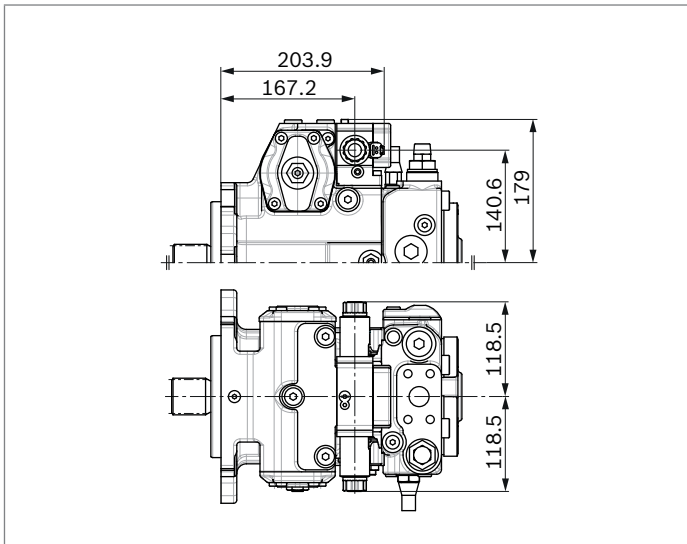

▼ **EZ** – Two-point control, electric

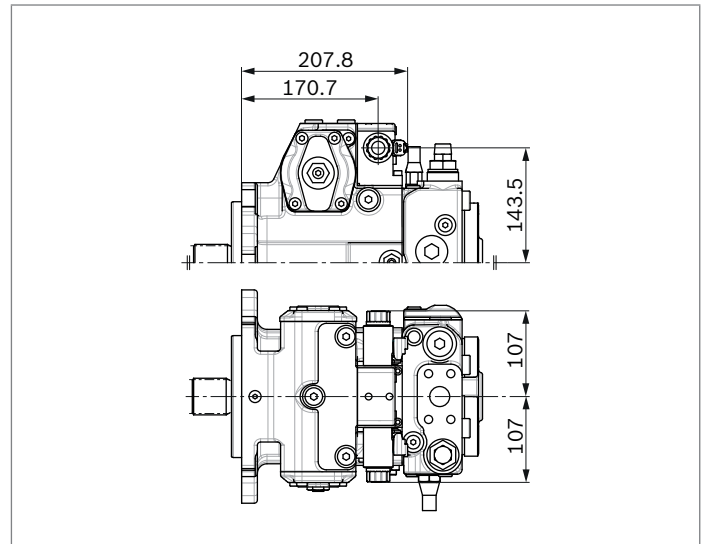

▼ **DG** – Hydraulic control, direct operated

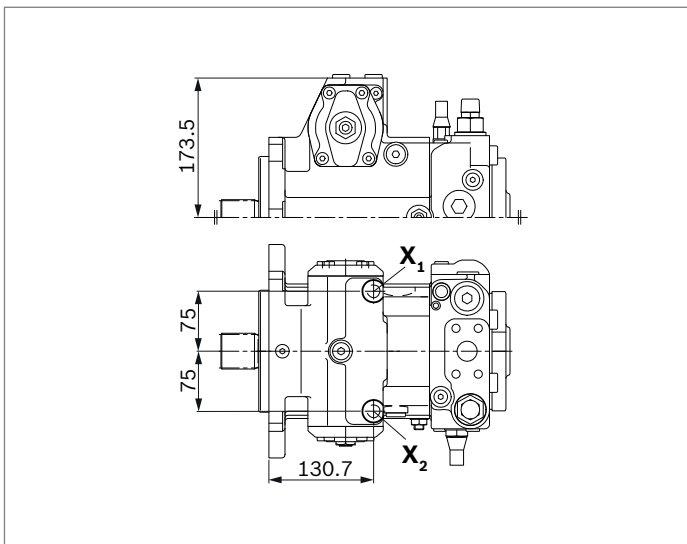

DA control valve

▼ **DA..2** – Fixed setting

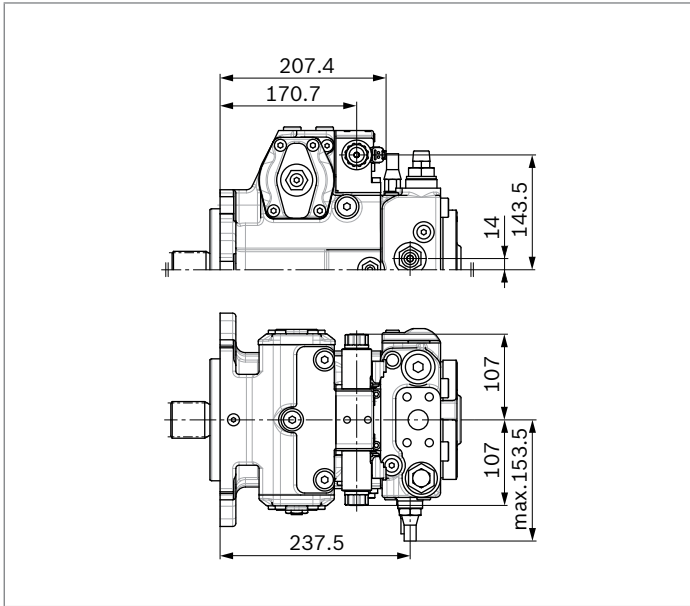

▼ **DA..3** – Mechanically adjustable with position lever

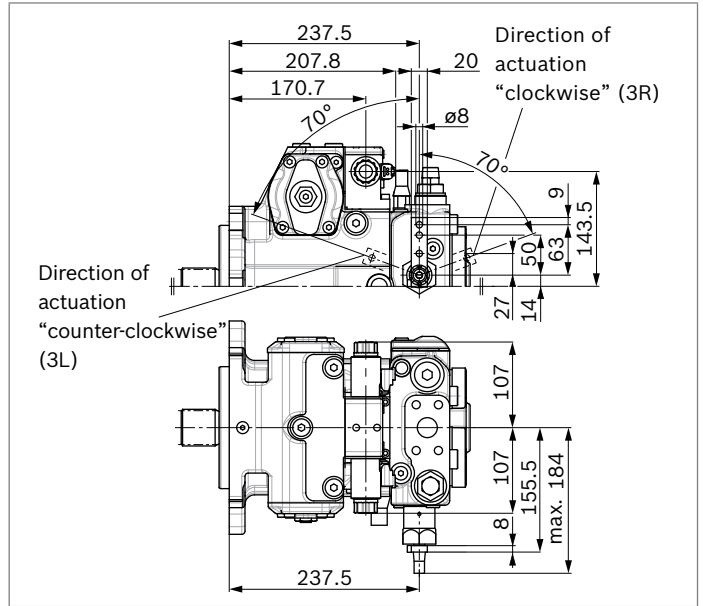

▼ **DA..7** – Fixed setting and ports for pilot control device

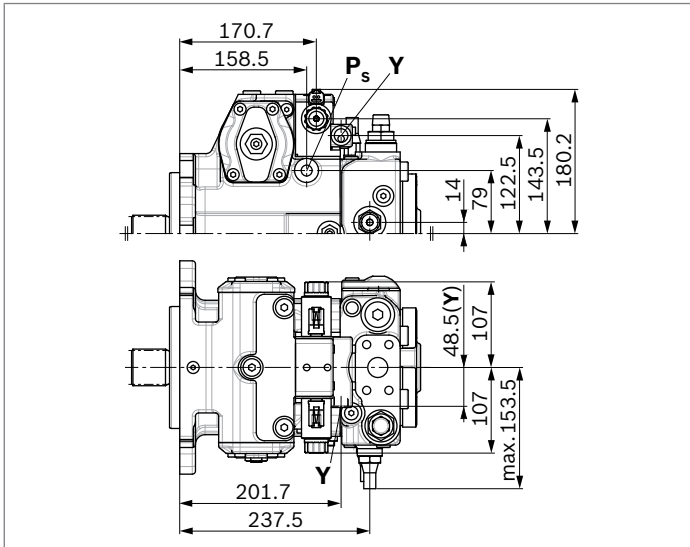

▼ **DA..8** – Fixed setting and inch valve mounted

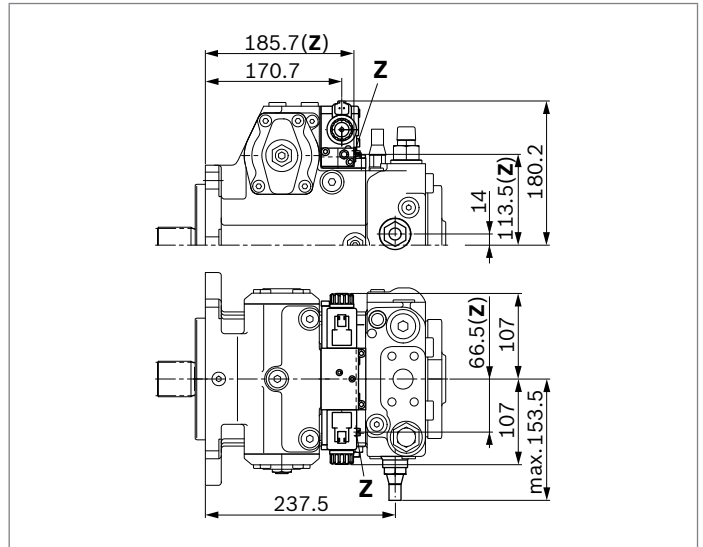

Dimensions, size 125

NV – Version without control module

Standard: SAE working port **A** and **B** top and bottom, suction port **S** bottom (02)

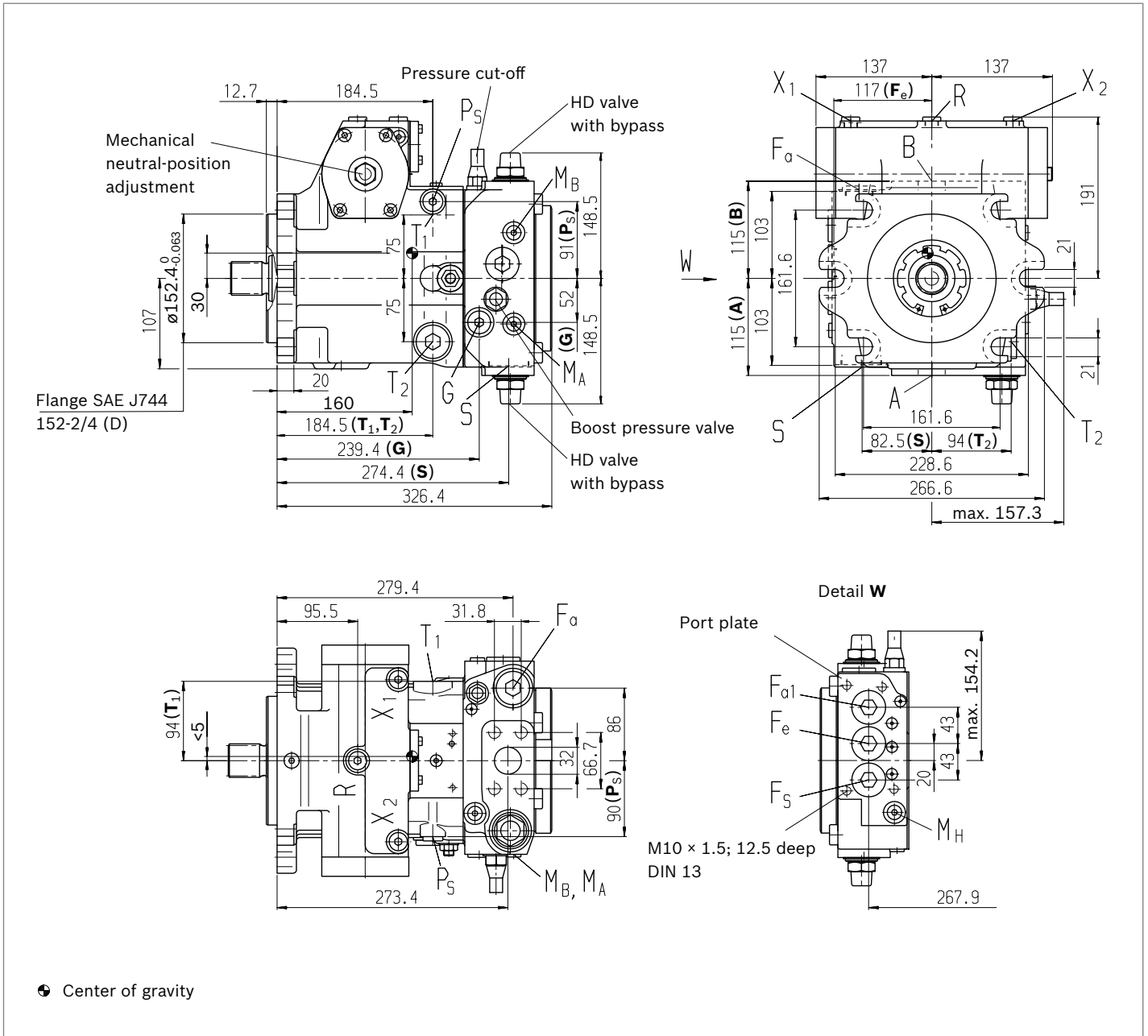

Notice

Option: SAE working port **A** and **B** top and bottom, suction port **S** top (03). Port plate (02) rotated through 180°, installation drawing on request

NV – Version without control module

Standard: SAE working port **A** and **B**, same side left, suction port **S** bottom (10)

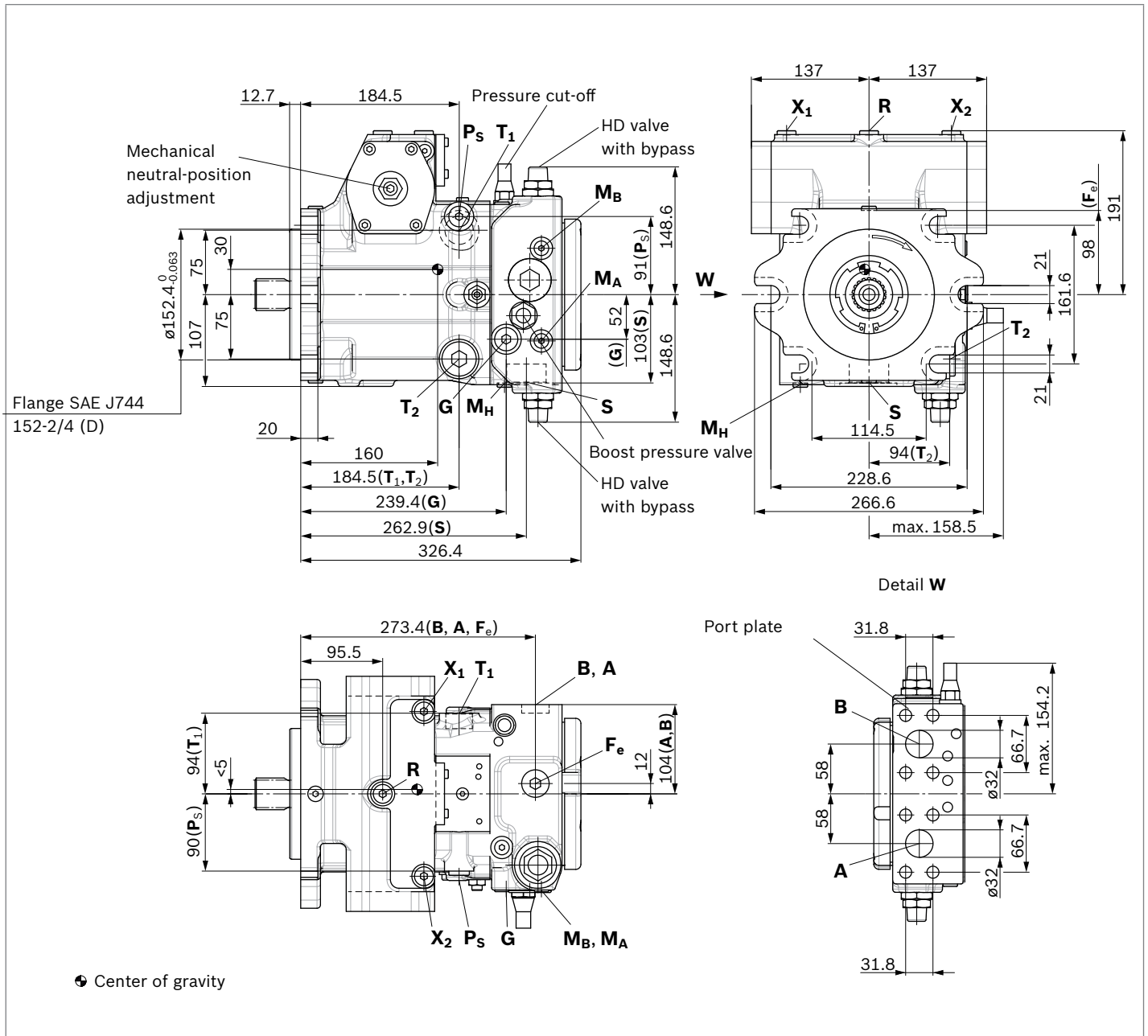

Notice
Option: SAE working port **A** and **B**, same side right, suction port **S** top (13), installation drawing on request

▼ Splined shaft DIN 5480

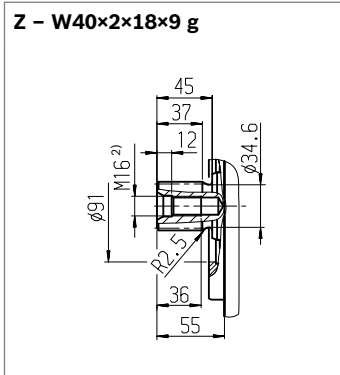

▼ Splined shaft DIN 5480

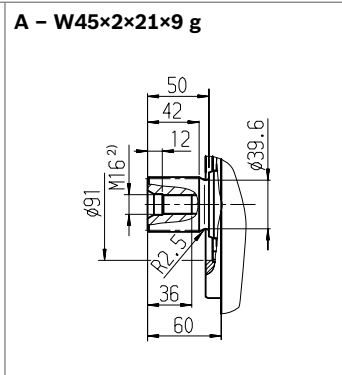

▼ Splined shaft ANSI B92.1a

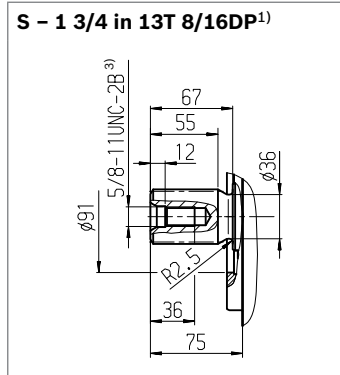

▼ Splined shaft ANSI B92.1a

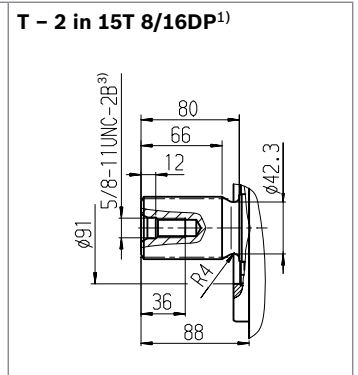

Ports	Standard	Size	p_{max} [bar] ⁴⁾	State ¹⁰⁾
A, B	Working port Fastening thread	SAEJ518 ⁵⁾ DIN 13	1 1/4 in M14 × 2; 19 deep	450 O
S	Suction port	DIN 3852 ⁸⁾	M48 × 2; 22 deep	5 O ⁶⁾
T₁	Drain port	DIN 3852 ⁸⁾	M33 × 2; 18 deep	3 O ⁷⁾
T₂	Drain port	DIN 3852 ⁸⁾	M33 × 2; 18 deep	3 X ⁷⁾
R	Air bleed port	DIN 3852 ⁸⁾	M16 × 1.5; 12 deep	3 X
X₁, X₂	Control pressure port (upstream of orifice)	DIN 3852 ⁸⁾	M16 × 1.5; 12 deep	40 X
X₁, X₂	Control pressure port (upstream of orifice, DG only)	DIN 3852 ⁸⁾	M16 × 1.5; 12 deep	40 O
X₃, X₄⁹⁾	Stroking chamber pressure port	DIN 3852 ⁸⁾	M12 × 1.5; 12 deep	40 X
G	Boost pressure port inlet	DIN 3852 ⁸⁾	M22 × 1.5; 12 deep	40 X
P_S	Pilot pressure port	DIN 3852 ⁸⁾	M18 × 1.5; 12 deep	40 X
P_S	Pilot pressure port (DA..7 only)	DIN 3852 ⁸⁾	M18 × 1.5; 12 deep	40 O
Y	Pilot pressure port outlet (DA..7 only)	DIN 3852 ⁸⁾	M18 × 1.5; 12 deep	40 O
M_A, M_B	Measuring port pressure A, B	DIN 3852 ⁸⁾	M12 × 1.5; 12 deep	450 X
M_H	Measuring port, high pressure	DIN 3852 ⁸⁾	M12 × 1.5; 12 deep	450 X
F_a	Boost pressure port inlet	DIN 3852 ⁸⁾	M33 × 2; 18 deep	40 X
F_{a1}	Boost pressure port inlet (attachment filter)	DIN 3852 ⁸⁾	M33 × 2; 18 deep	40 X
F_e	Boost pressure port outlet	DIN 3852 ⁸⁾	M33 × 2; 18 deep	40 X
F_S	Line from filter to suction port (cold start)	DIN 3852 ⁸⁾	M33 × 2; 18 deep	40 X
Y₁, Y₂	Pilot pressure port (pilot signal HD only)	DIN 3852 ⁸⁾	M14 × 1.5; 12 deep	40 O
Z	Pilot pressure port (inch signal DA..8 only)	DIN 3852 ⁸⁾	M10 × 1; 8 deep	40 X

1) Involute spline according to ANSI B92.1a, 30° pressure angle, flat root, side fit, tolerance class 5
 2) Center bore according to DIN 332 (thread according to DIN 13)
 3) Thread according to ASME B1.1
 4) Depending on the application, momentary pressure peaks can occur. Keep this in mind when selecting measuring devices and fittings.
 5) Only dimensions according to SAE J518, metric fastening thread is a deviation from the standard.

6) Plugged at external boost pressure supply.
 7) Depending on installation position, **T₁** or **T₂** must be connected (see also installation instructions on page 71).
 8) The countersink can be deeper than as specified in the standard.
 9) Optional, see page 62
 10) O = Must be connected (plugged when delivered)
 X = Plugged (in normal operation)

▼ **HD** – Proportional control, hydraulic, pilot-pressure related

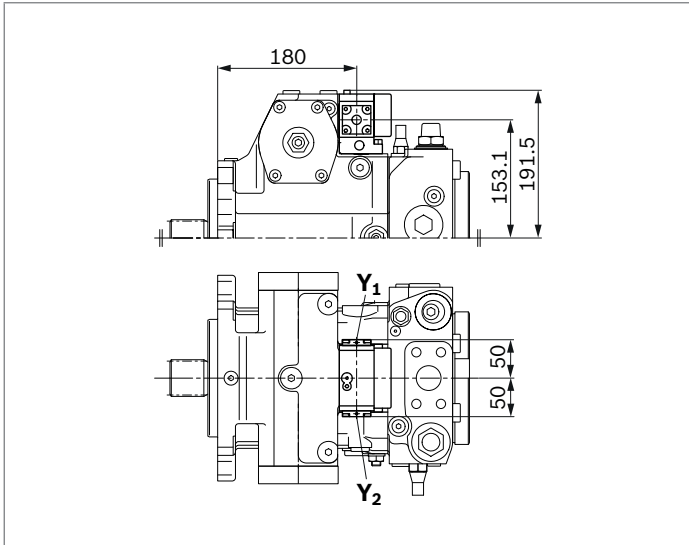

▼ **HW** – Proportional control, hydraulic, mechanical servo

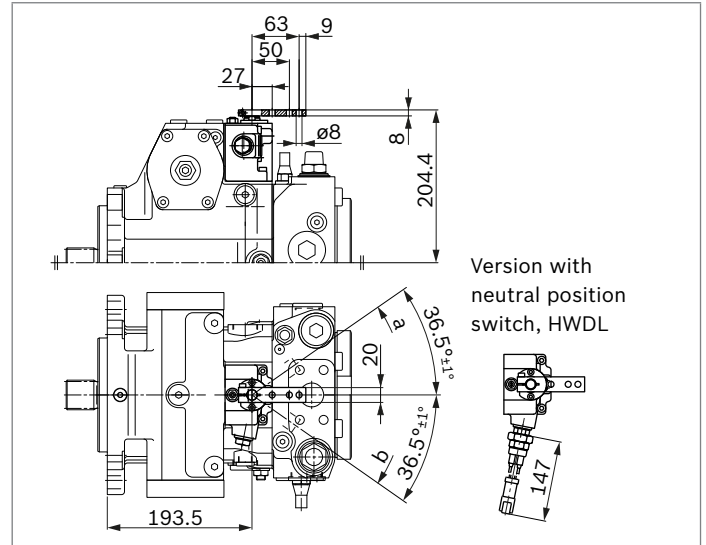

▼ **EP** – Proportional control, electric

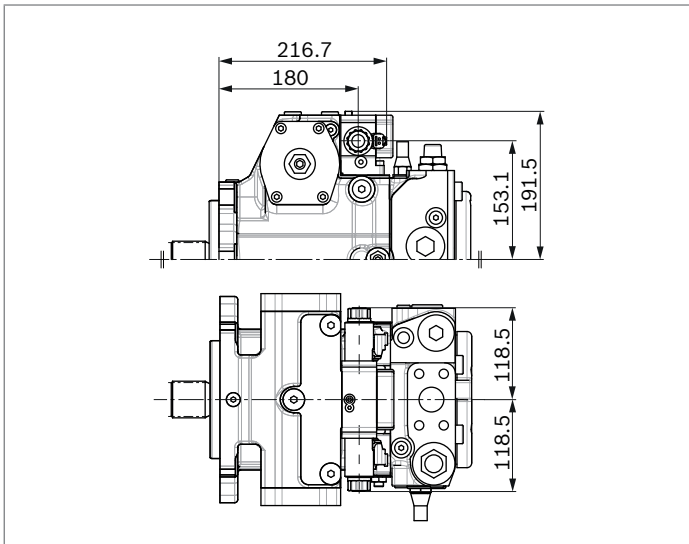

▼ **EZ** – Two-point control, electric

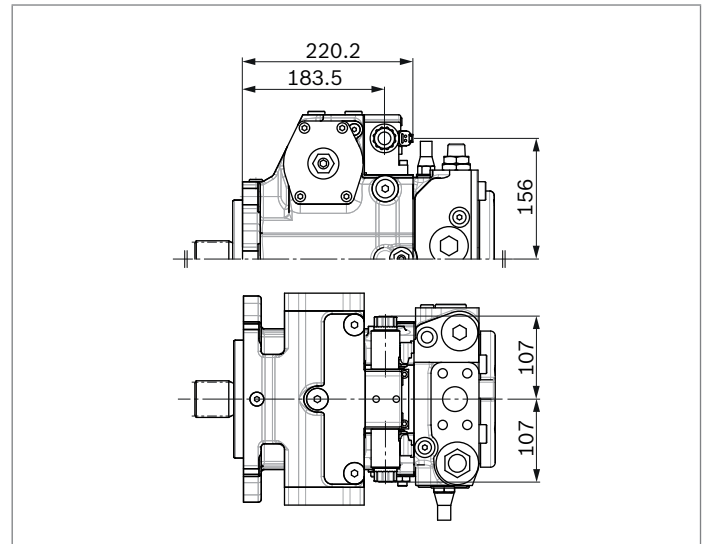

▼ **DG** – Hydraulic control, direct operated

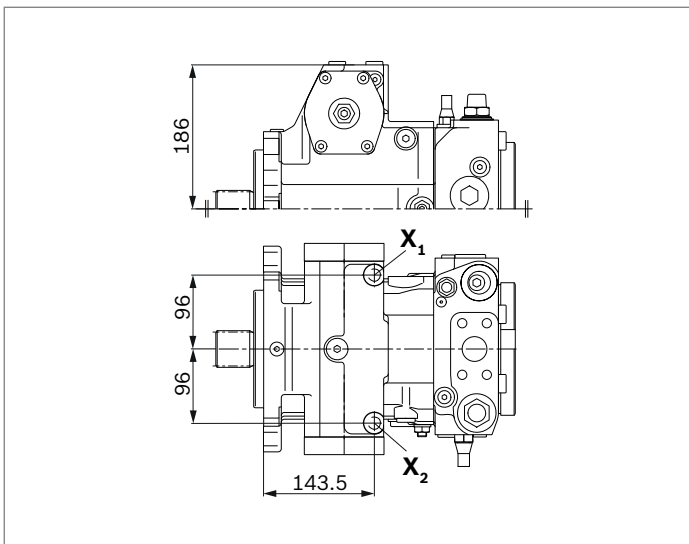

DA control valve

▼ **DA..2** – Fixed setting

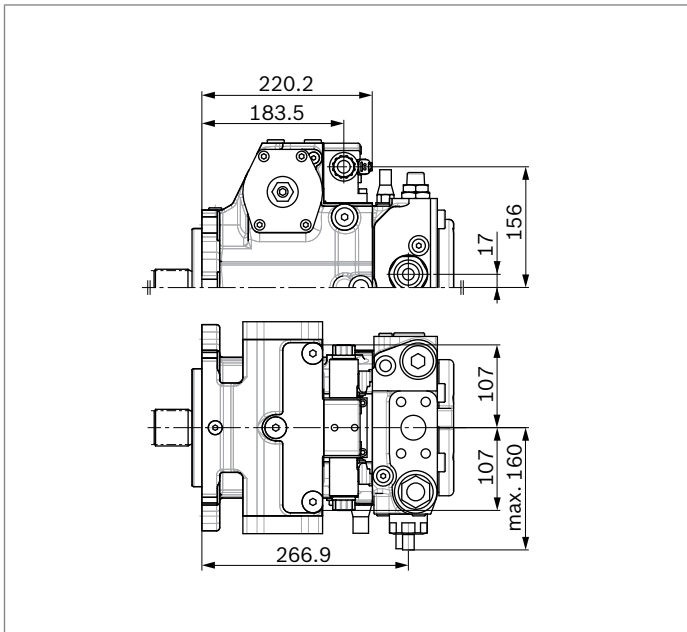

▼ **DA..3** – Mechanically adjustable with position lever

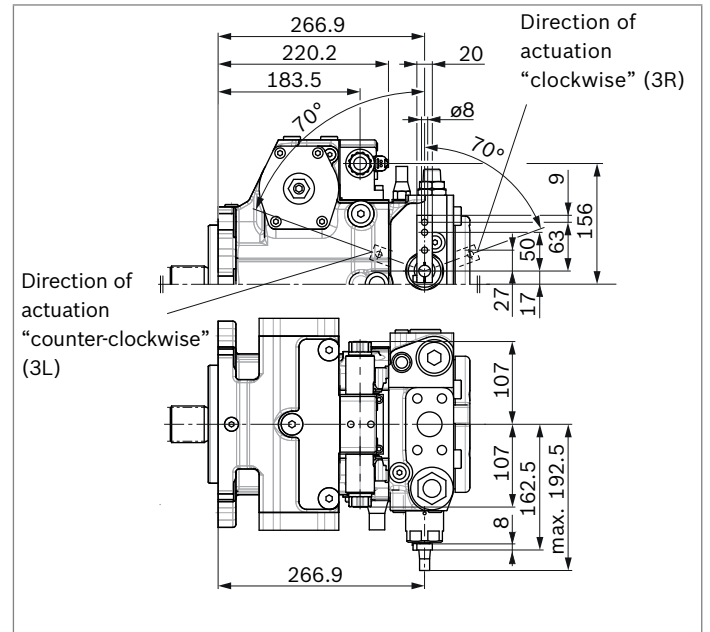

▼ **DA..7** – Fixed setting and ports for pilot control device

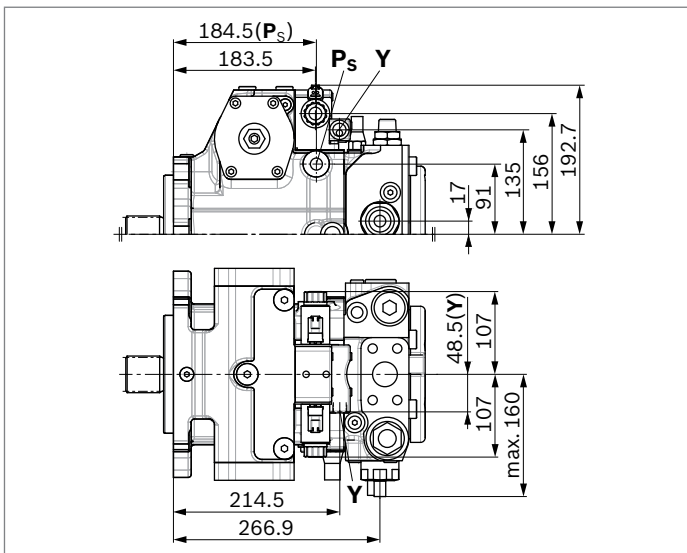

▼ **DA..8** – Fixed setting and inch valve mounted

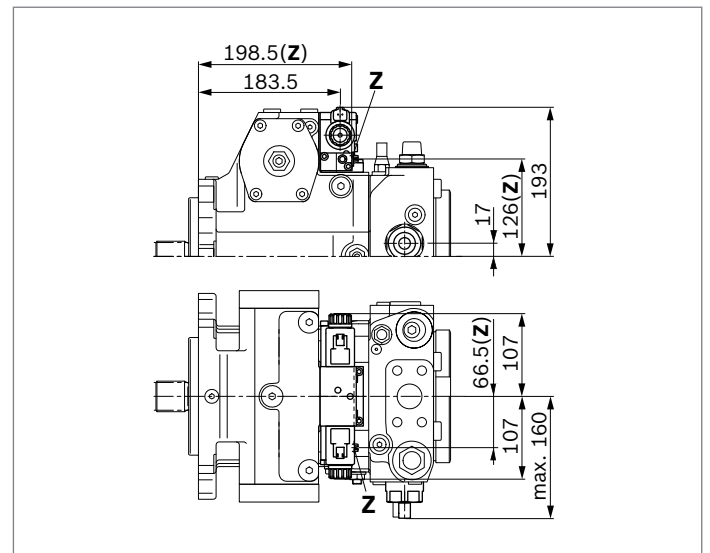

Dimensions, size 180

NV – Version without control module

Standard: SAE working port **A** and **B** top and bottom, suction port **S** bottom (02)

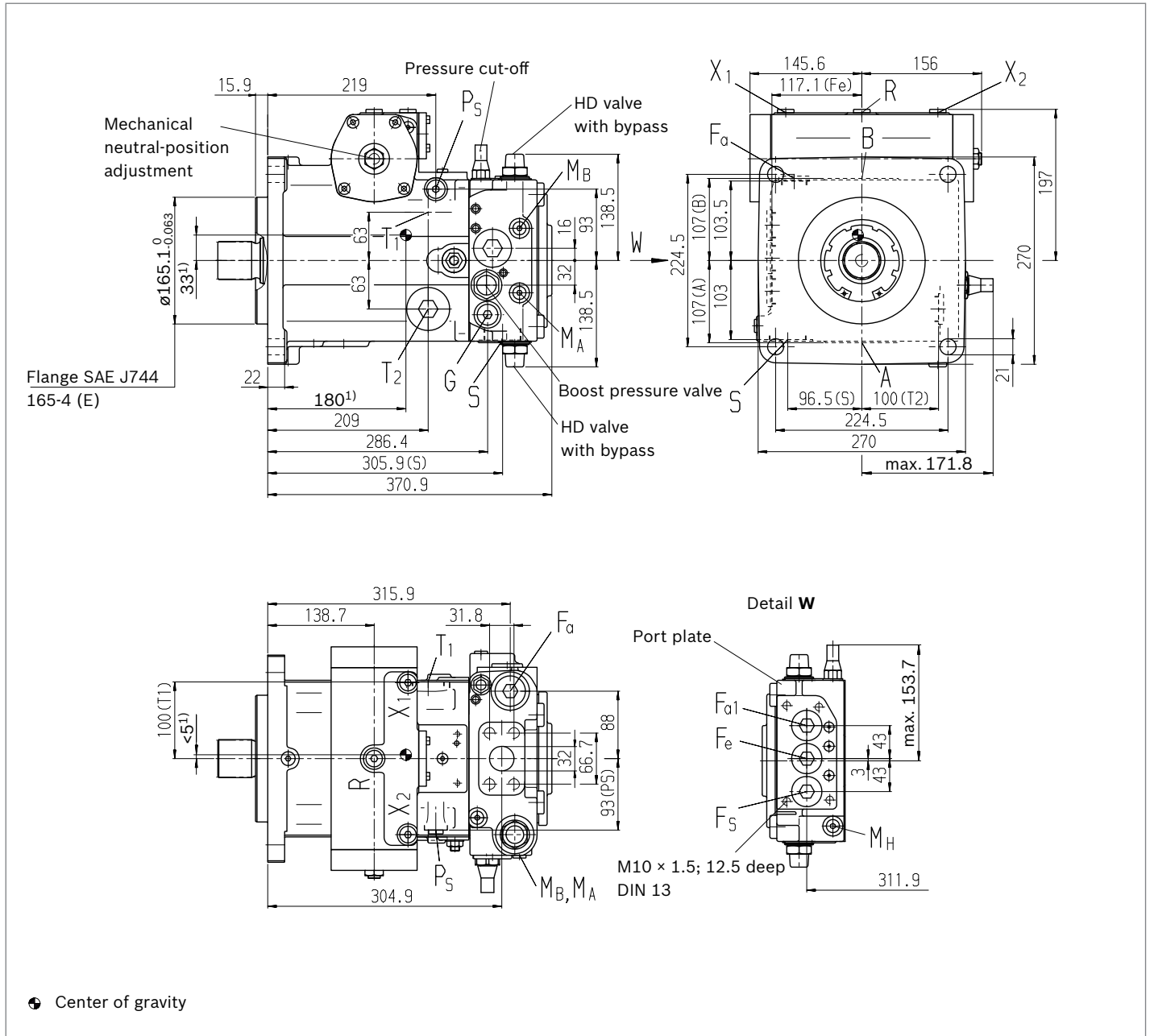

Notice

Option: SAE working port **A** and **B** top and bottom, suction port **S** top (03). Port plate (02) rotated through 180°, installation drawing on request

1) Center of gravity

▼ Splined shaft DIN 5480

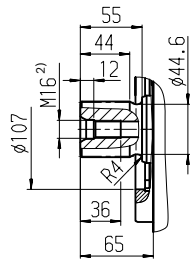
Z – W50×2×24×9 g

▼ Splined shaft ANSI B92.1a

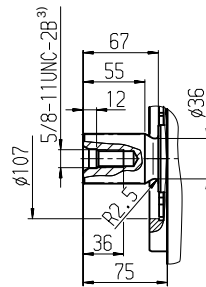
S – 1 3/4 in 13T 8/16DP¹⁾

▼ Splined shaft ANSI B92.1a

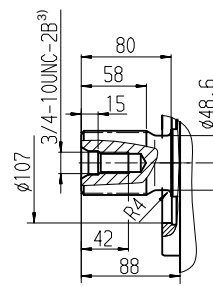
T – 2 1/4 in 17T 8/16DP¹⁾

Ports		Standard	Size	p_{max} [bar] ⁴⁾	State ¹⁰⁾
A, B	Working port	SAEJ518 ⁵⁾	1 1/4 in	450	O
	Fastening thread	DIN 13	M14 × 2; 19 deep		
S	Suction port	DIN 3852 ⁸⁾	M48 × 2; 22 deep	5	O ⁶⁾
T₁	Drain port	DIN 3852 ⁸⁾	M42 × 2; 20 deep	3	O ⁷⁾
T₂	Drain port	DIN 3852 ⁸⁾	M42 × 2; 20 deep	3	X ⁷⁾
R	Air bleed port	DIN 3852 ⁸⁾	M16 × 1.5; 12 deep	3	X
X₁, X₂	Control pressure port (upstream of orifice)	DIN 3852 ⁸⁾	M16 × 1.5; 12 deep	40	X
X₁, X₂	Control pressure port (upstream of orifice, DG only)	DIN 3852 ⁸⁾	M16 × 1.5; 12 deep	40	O
X₃, X₄⁹⁾	Stroking chamber pressure port	DIN 3852 ⁸⁾	M12 × 1.5; 12 deep	40	X
G	Boost pressure port inlet	DIN 3852 ⁸⁾	M22 × 1.5; 14 deep	40	X
P_S	Pilot pressure port	DIN 3852 ⁸⁾	M18 × 1.5; 12 deep	40	X
P_S	Pilot pressure port (DA..7 only)	DIN 3852 ⁸⁾	M18 × 1.5; 12 deep	40	O
Y	Pilot pressure port outlet (DA..7 only)	DIN 3852 ⁸⁾	M18 × 1.5; 12 deep	40	O
M_A, M_B	Measuring port pressure A, B	DIN 3852 ⁸⁾	M12 × 1.5; 12 deep	450	X
M_H	Measuring port, high pressure	DIN 3852 ⁸⁾	M12 × 1.5; 12 deep	450	X
F_a	Boost pressure port inlet	DIN 3852 ⁸⁾	M33 × 2; 18 deep	40	X
F_{a1}	Boost pressure port inlet (attachment filter)	DIN 3852 ⁸⁾	M33 × 2; 18 deep	40	X
F_e	Boost pressure port outlet	DIN 3852 ⁸⁾	M33 × 2; 18 deep	40	X
F_S	Line from filter to suction port (cold start)	DIN 3852 ⁸⁾	M33 × 2; 18 deep	40	X
Y₁, Y₂	Pilot pressure port (pilot signal HD only)	DIN 3852 ⁸⁾	M14 × 1.5; 12 deep	40	O
Z	Pilot pressure port (inch signal DA..8 only)	DIN 3852 ⁸⁾	M10 × 1; 8 deep	40	X

- 1) Involute spline according to ANSI B92.1a, 30° pressure angle, flat root, side fit, tolerance class 5
- 2) Center bore according to DIN 332 (thread according to DIN 13)
- 3) Thread according to ASME B1.1
- 4) Depending on the application, momentary pressure peaks can occur. Keep this in mind when selecting measuring devices and fittings.
- 5) Only dimensions according to SAE J518, metric fastening thread is a deviation from the standard.

- 6) Plugged at external boost pressure supply.
- 7) Depending on installation position, **T₁** or **T₂** must be connected (see also installation instructions on page 71).
- 8) The countersink can be deeper than as specified in the standard.
- 9) Optional, see page 62
- 10) O = Must be connected (plugged when delivered)
X = Plugged (in normal operation)

▼ **HD** – Proportional control, hydraulic, pilot-pressure related

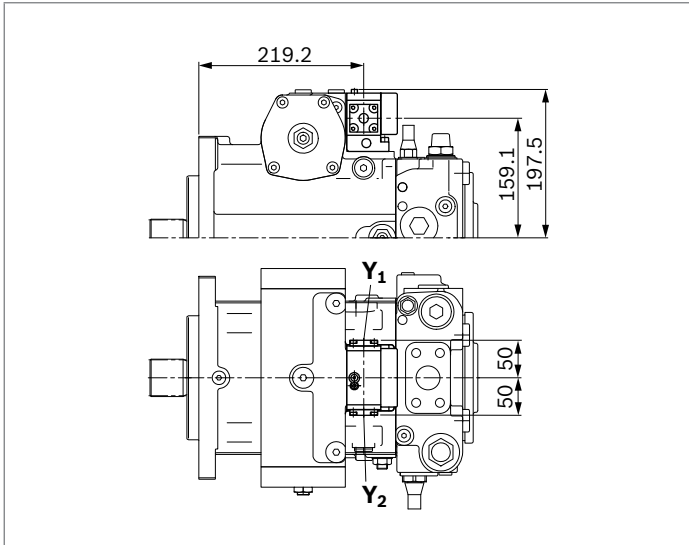

▼ **HW** – Proportional control, hydraulic, mechanical servo

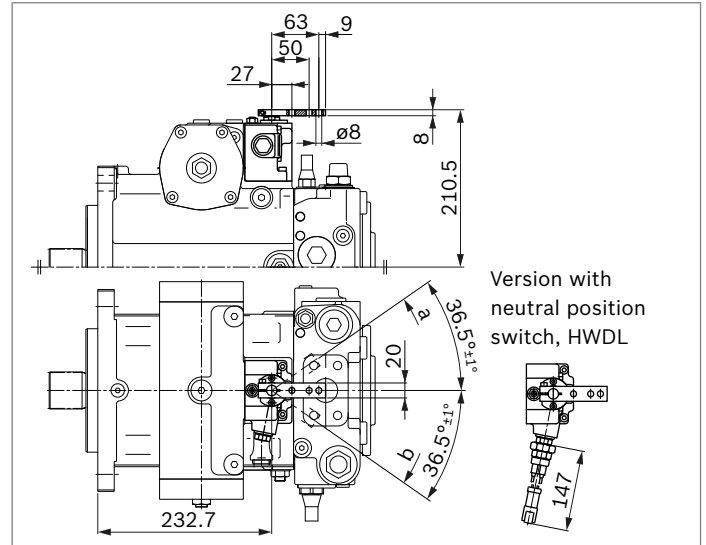

▼ **EP** – Proportional control, electric

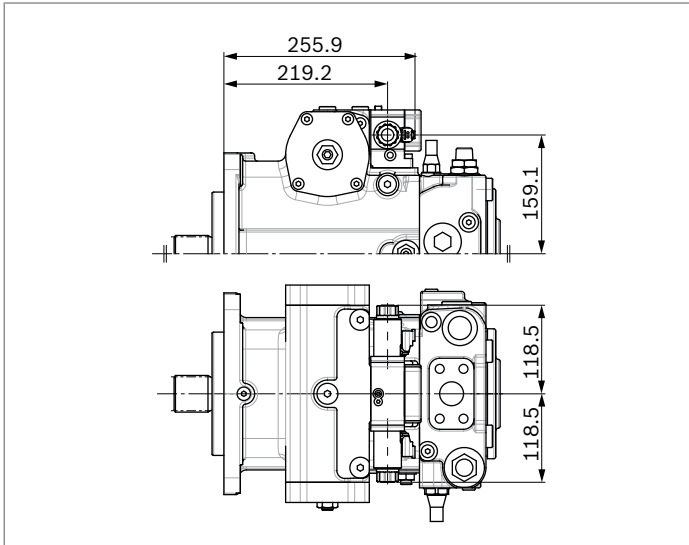

▼ **EZ** – Two-point control, electric

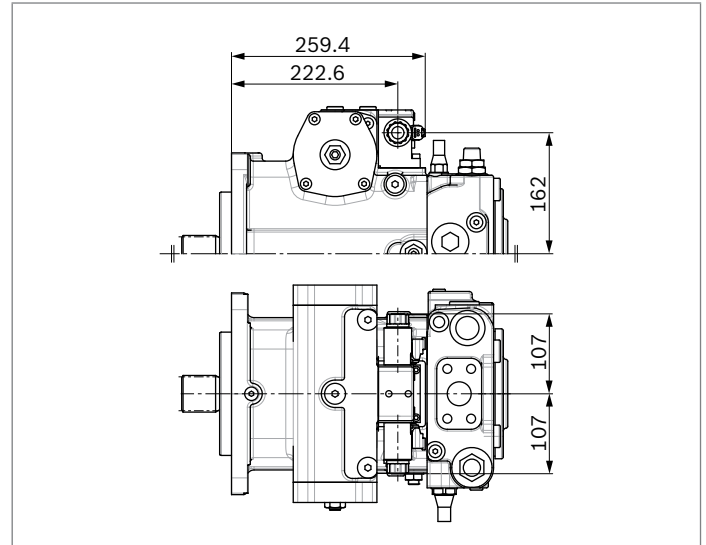

▼ **DG** – Hydraulic control, direct operated

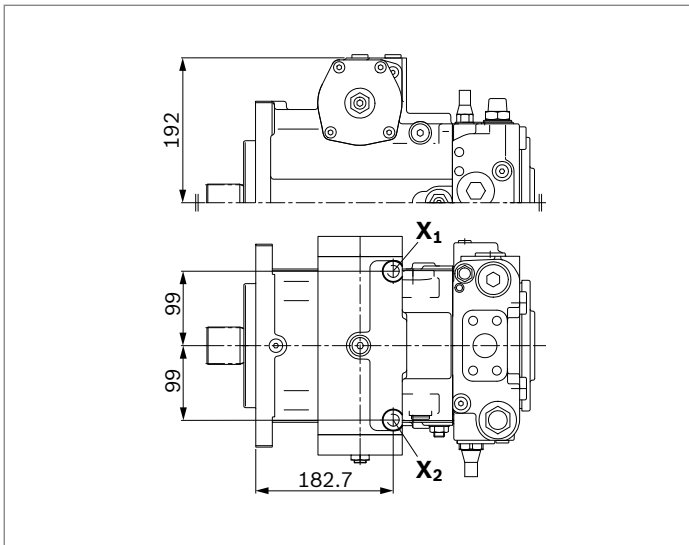

DA control valve

▼ **DA..2** – Fixed setting

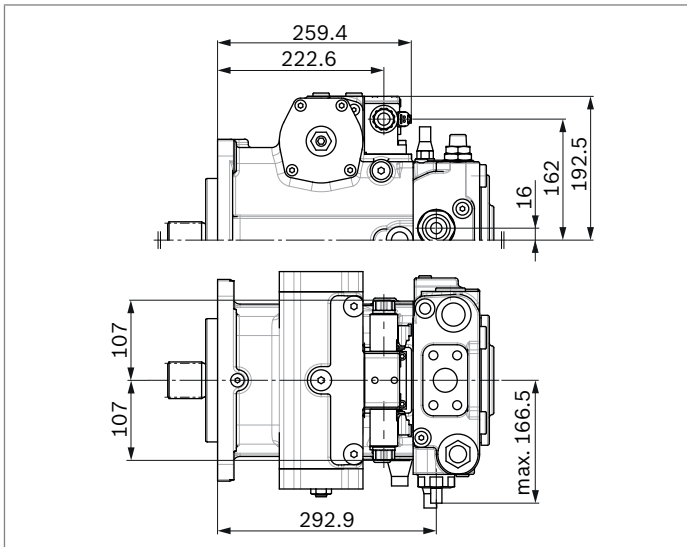

▼ **DA..7** – Fixed setting and ports for pilot control device

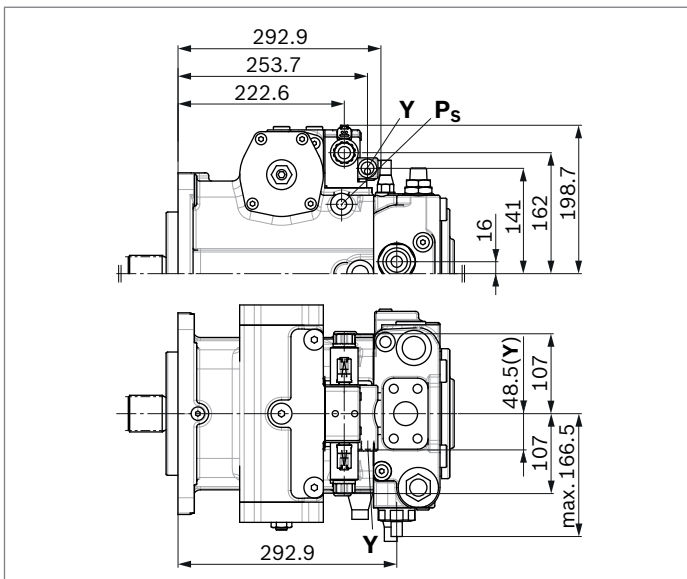

▼ **DA..8** – Fixed setting and inch valve mounted

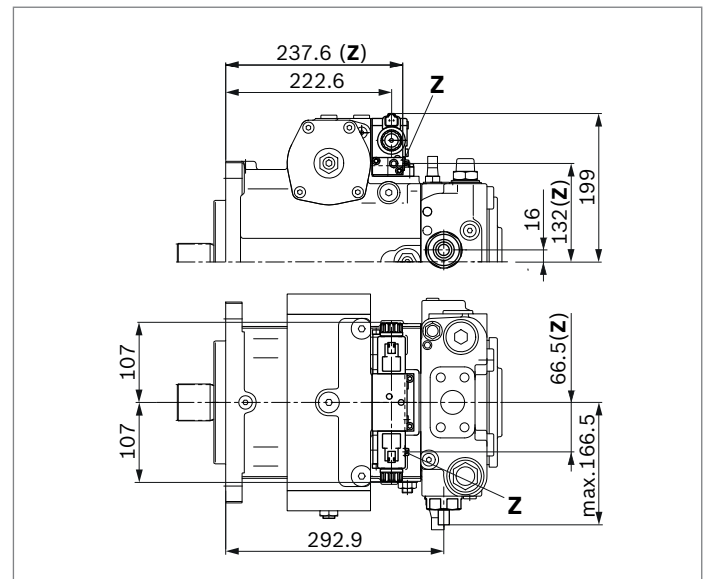

Dimensions, through drive

Flange SAE J744	Hub for splined shaft ¹⁾	28	40	56	71	90	125	180	Code
Without through drive		•	•	•	•	•	•	•	00
82-2 (A)	5/8 in 9T 16/32DP	•	•	•	•	•	•	•	01

▼ **N00** – without boost pump, without through drive / **F00** – with boost pump, without through drive

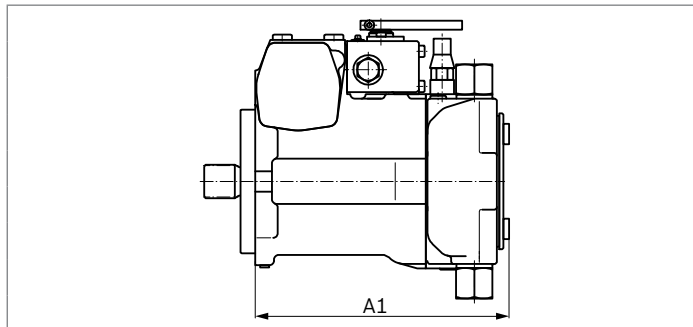

NG	A1 (N00)	A1 (F00)
28	213.9	223.4
40	220.2	235.7
56	239.4	256.4
71	279.1	293.6
90	287	301
125	320.9	326.4
180	370.9	370.9

▼ **F01/K01**⁴⁾

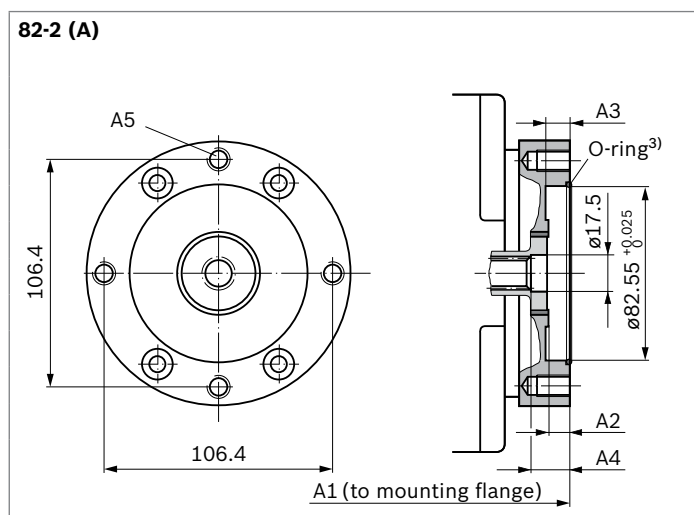

NG	A1 (F01)	A1 (K01)	A2	A3	A4
28	227.9	227.9	7.5	7.5	14.5
40	239.7	234.2	9	9	18
56	261.4	254.9	10	10	18
71	297.6	297.6	9	10	17
90	304	304	9	8	-
125	330.9	330.9	10.5	9	-
180	378.4	378.4	7.5	7.5	15.5
NG	A5 ²⁾				
28 to 125	M10 × 1.5; 15 deep				
180	M10 × 1.5; 16.5 deep				

1) Involute spline according to ANSI B92.1a, 30° pressure angle, flat root, side fit, tolerance class 5

2) Thread according to DIN 13

3) O-ring included in the scope of delivery

4) The illustration shows the 2-hole version. Please state in plain text whether the 2-hole horizontal or the 2-hole vertical version is used.

Flange SAE J744	Hub for splined shaft ¹⁾	28	40	56	71	90	125	180	Code
101-2 (B)	7/8 in 13T 16/32DP	●	●	●	●	●	●	●	02
	1 in 15T 16/32DP	●	●	●	●	●	●	●	04
127-2 (C)	1 in 15T 16/32DP	-	●	-	-	-	-	-	09

▼ **F02/K02; F04/K04⁴⁾**

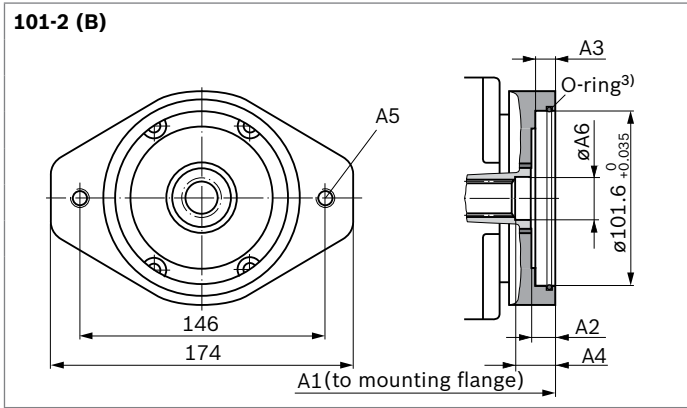

NG	A1	A2	A3	A4 (02)	A4 (04)	A5 ²⁾
28	230.4	9.7	9.7	16.2	13.7	M12 × 1.75; 19 deep
40	240.7	11	11 ⁵⁾	17	16	M12 × 1.75; 19 deep
56	262.4	12	11	19.5	18.5	M12 × 1.75; 19 deep
øA6						
F02 / K02	24					
F04 / K04	27					

▼ **F02/K02; F04/K04⁴⁾**

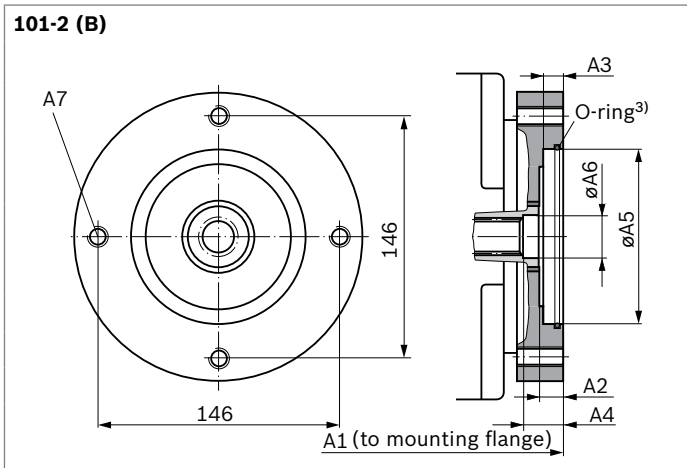

NG	A1	A2	A3	A4 (02)	A4 (04)	øA5	(K)	(F)
71	300.6	13	9.8	17	15.5	101.6 ^{+0.035} ₀	^{+0.035} ₀	
90	305	9	11	17	15	101.6 ^{+0.035} ₀	^{+0.022} ₀	
125	330.9	10	11	17	16.5	101.6 ^{+0.025} ₀	^{+0.025} ₀	
180	381.4	11	11	19	18	101.6 ^{+0.035} ₀	^{+0.035} ₀	
NG	A7²⁾							
71, 90, 180	M12 × 1.75; 21 deep							
125	M12 × 1.75; 18 deep							
øA6								
F02 / K02	24							
F04 / K04	27							

▼ **F09/K09**

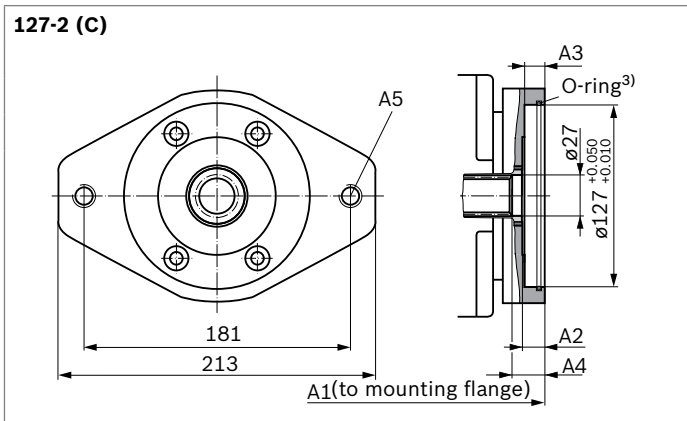

NG	A1	A2	A3	A4
40	244.7	14	14	19.5
NG	A5²⁾			
40	M16 × 2; 20 deep			

- 1) Involute spline according to ANSI B92.1a, 30° pressure angle, flat root, side fit, tolerance class 5
- 2) Thread according to DIN 13
- 3) O-ring included in the scope of delivery

- 4) The illustration shows the 2-hole version. Please state in plain text whether the 2-hole horizontal or the 2-hole vertical version is used.
- 5) For F04/K04 9.7 mm

Flange SAE J744	Hub for splined shaft	28	40	56	71	90	125	180	Code
127-2 (C)	1 1/4 in 14T 12/24DP ¹⁾	-	-	●	●	●	●	●	07
152-2/4 (D)	W35 2×16×9 g (according to DIN 5480)	-	-	-	-	●	-	-	73
	1 3/4 in 13T 8/16DP ¹⁾	-	-	-	-	-	●	●	69

▼ **F07/K07⁴⁾**

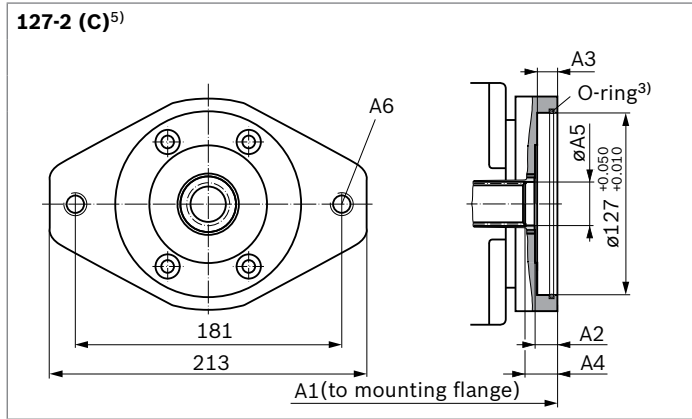

NG	A1	A2	A3	A4	øA5	A6 ²⁾
56	266.4	15	14	17.5	32.7	M16 × 2; 20 deep
71	303.6	15	13.5	20	33.5	M16 × 2; 24 deep

▼ **F07/K07⁴⁾**

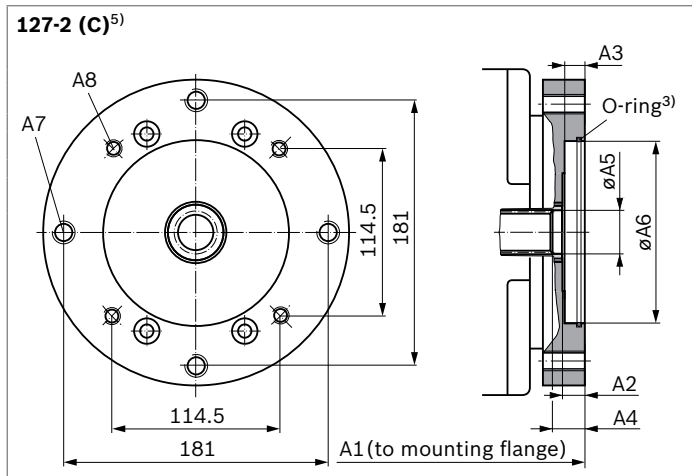

NG	A1	A2	A3	A4	øA5	øA6
90	309	13	14	20.5	33.5	127 ^{+0.025} / ₀
125	335.9	15	15.5	22.5	33.5	127 ^{+0.025} / ₀
180⁷⁾	384.4	14	19	17	33.5	127 ^{+0.050} / _{+0.010}
NG	A7 ²⁾		A8 ²⁾			
90, 125, 180⁷⁾	M16 × 2; 23 deep		M12 × 1.75; 18 deep			

▼ **F73/K73; F69/K69⁶⁾**

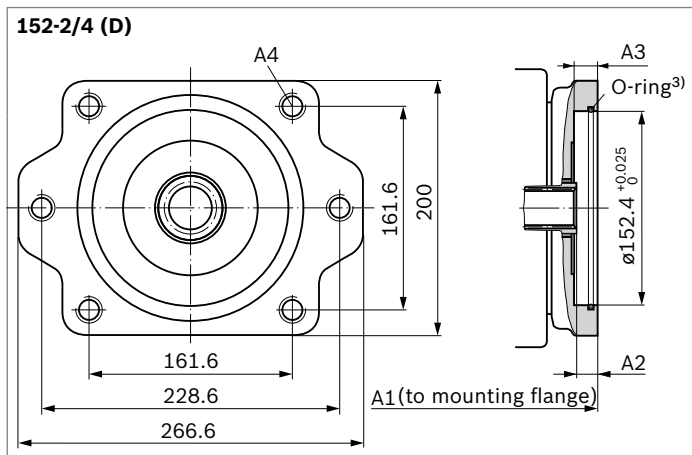

NG	A1	A2	A3	A4 ²⁾
90	309	12	14	M20 × 2.5; 20 deep
125	343.9	18	14	M20 × 2.5; 20 deep
180	391.9	20.9	18	M20 × 2.5; 20 deep

- 1) Involute spline according to ANSI B92.1a, 30° pressure angle, flat root, side fit, tolerance class 5
- 2) Thread according to DIN 13
- 3) O-ring included in the scope of delivery
- 4) The illustration shows the 4- and the 2-hole version. Please state in plain text whether the 4-hole, the 2-hole horizontal or the 2-hole vertical version is used.
- 5) NG90 to 180 with additional 4-hole-flange (127-4)
- 6) The illustration shows the 4+2-hole version. Please state in plain text whether the 2-hole, the 4-hole or the 4+2-hole vertical version is used.
- 7) Size 180 only with SAE 2-hole flange

Flange SAE J744	Hub for splined shaft ¹⁾	28	40	56	71	90	125	180	Code
165-4 (E)	1 3/4 in 13T 8/26DP	-	-	-	-	-	-	●	72

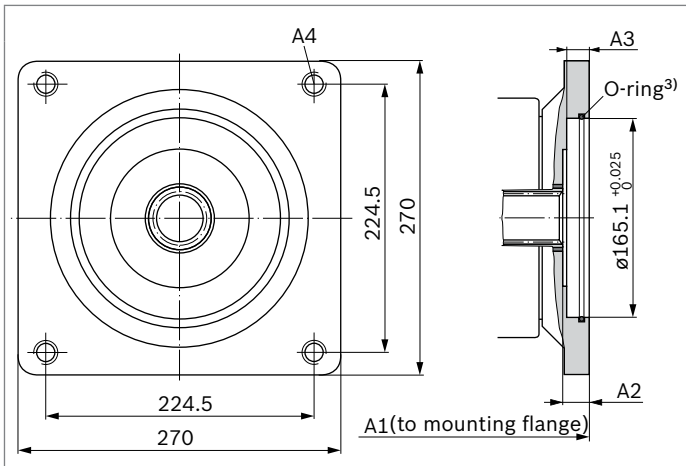
▼ **F72/K72**

NG	A1	A2	A3	A4 ²⁾
180	391.4	20.9	18	M20 × 2.5; 20 deep

- 1) Involute spline according to ANSI B92.1a, 30° pressure angle, flat root, side fit, tolerance class 5
- 2) Thread according to DIN 13
- 3) O-ring included in the scope of delivery

Overview of mounting options

Through drive ¹⁾			Mounting option – 2. pump					
Flange	Hub for splined shaft	Code	A4VG/32 NG (shaft)	A10V(S)O/3X NG (shaft)	A10V(S)O/5X NG (shaft)	A11VO/1 NG (shaft)	A10VG NG (shaft)	External gear pump ²⁾
82-2 (A)	5/8 in	F/K01	-	18 (U)	10, 18 (U)	-	-	AZPF NG4 to 22
101-2 (B)	7/8 in	F/K02	-	28 (S) 45 (U)	28 (S) 45 (U)	-	18 (S)	AZPN NG20 to 36 AZPG NG32 to 50
	1 in	F/K04	28 (S)	45 (S)	45 (S) 60, 63, 72 (U)	40 (S)	28 (S) 45 (S)	-
127-2 (C) ³⁾	1 in	F/K09	40 (U)	71 (U)	60, 63, 71 (U)	-	-	-
	1 1/4 in	F/K07	40, 56, 71 (S)	71 (S) 100 (U)	60, 63, 71 (S) 85, 100 (U)	60 (S)	63 (S)	-
152-2/4 (D)	W35	F/K73	90 (Z)	-	-	-	-	-
	1 3/4 in	F/K69	90, 125 (S)	140 (S)	-	95, 130, 145 (S)	-	-
165-4 (E)	1 3/4 in	F/K72	180 (S)	-	-	190 (S)	-	-

- 1) Availability of the individual sizes, see type code on page 3.
- 2) Bosch Rexroth recommends special versions of the gear pumps. Please contact us.

- 3) A10VO/5X with 4-hole flange attachable only to A4VG NG90 to 180

Combination pumps A4VG + A4VG

Total length A

A4VG 1st pump	A4VG 2. Pump ¹⁾						
	NG28	NG40	NG56	NG71	NG90	NG125	NG180
NG28	453.8	–	–	–	–	–	–
NG40	464.1	480.4	–	–	–	–	–
NG56	485.8	502.1	522.8	–	–	–	–
NG71	524.0	539.3	560.0	597.2	–	–	–
NG90	528.4	544.7	565.4	602.6	610.0	–	–
NG125	554.3	571.6	592.3	629.5	644.9	670.3	–
NG180	604.8	620.1	640.8	678.0	692.9	718.3	762.8

By using combination pumps, it is possible to have independent circuits without the need for splitter gearboxes. When ordering combination pumps, the type designations of the 1st and 2nd pumps must be linked by a “+”.

Order example:

A4VG56EP3D1/32R-NAC02F073SP + A4VG56EP3D1/32R-NSC02F003SP

A tandem pump, with two pumps of equal size, is permissible without additional supports, assuming that the dynamic acceleration does not exceed maximum 10 g (= 98.1 m/s²).

From size 71 upward, we recommend using the 4-hole mounting flange.

For combination pumps consisting of more than two pumps, the mounting flange must be rated for the permissible moment of inertia, please contact us.

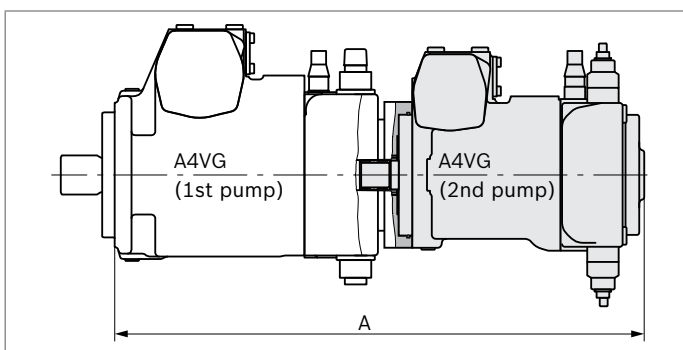

1) 2nd pump without through drive and with boost pump, F00

High-pressure relief valves

The two high-pressure relief valves protect the hydrostatic transmission (pump and motor) from overloading. They limit the maximum pressure in the respective high-pressure line and serve simultaneously as boost valves.

High-pressure relief valves are not working valves and are only suitable for pressure peaks or high rates of pressure change.

Setting ranges

High-pressure relief valve, direct operated (NG28 to 56)	Differential pressure setting Δp_{HD}
Valve setting range 3, 5 Δp 250 to 420 bar (see type code)	420 bar
	400 bar
	360 bar
	340 bar
	320 bar
	300 bar
	270 bar
	250 bar
Valve setting range 4, 6 Δp 100 to 250 bar (see type code)	250 bar
	230 bar
	200 bar
	150 bar
	100 bar

High-pressure relief valve, pilot operated (NG71 to 180)	Differential pressure setting Δp_{HD}
Valve setting range 1 Δp 100 to 420 bar (see type code)	420 bar
	400 bar
	360 bar
	340 bar
	320 bar
	300 bar
	270 bar
	250 bar
	230 bar
	200 bar
	150 bar
	100 bar

Settings on high-pressure relief valve A and B	
Differential pressure setting	$\Delta p_{HD} = \dots$ bar
Cracking pressure of the HD valve (at q_{v1}) ($p_{max} = \Delta p_{HD} + p_{Sp}$)	$p_{max} = \dots$ bar

- ▶ The valve settings are made at $n = 1000$ rpm and at $V_{g\ max}$ (q_{v1}). There may be deviations in the cracking pressures with other operating parameters.
- ▶ When ordering, state differential pressure setting in plain text.

▼ Example

Working pressure	Boost pressure	Safety	Differential pressure
$p_{A,B}$ 400 bar	- 30 bar	+ 30 bar	= Δp_{HD} 400 bar

▼ Setting diagram

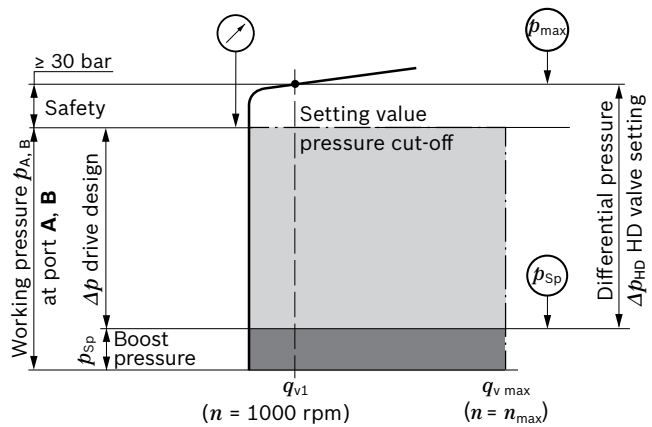

Bypass function

A connection between the two high-pressure channels **A** and **B** can be established using the bypass valve (e.g. for machine towing).

▶ Towing speed

The maximum towing speed is dependent on the gear ratio in the vehicle and must be calculated by the vehicle manufacturer. The corresponding flow of $q_v = 30$ l/min may not be exceeded.

▶ Towing distance

The vehicle may only be towed out of the immediate danger zone.

For further information on the bypass function, see the instruction manual.

Notice

The bypass function and the pilot-operated high pressure relief valves (size 71 to 180) are not illustrated in the circuit diagrams.

Pressure cut-off

The pressure cut-off is a pressure control which, after reaching the set pressure, adjusts the displacement of the pump back to $V_{g \text{ min}}$.

This valve prevents the operation of the high-pressure relief valves when accelerating or decelerating.

The high-pressure relief valves protect against the pressure peaks which occur during fast swiveling of the swashplate and limit the maximum pressure in the system.

The setting range of the pressure cut-off may be anywhere within the entire working pressure range. However, it must be set 30 bar lower than the setting value of the high-pressure relief valves (see setting diagram, page 59).

Please state the setting value of the pressure cut-off in plain text when ordering.

▼ Circuit diagram with pressure cut-off

Example: Two-point electric control, E21D/E22D

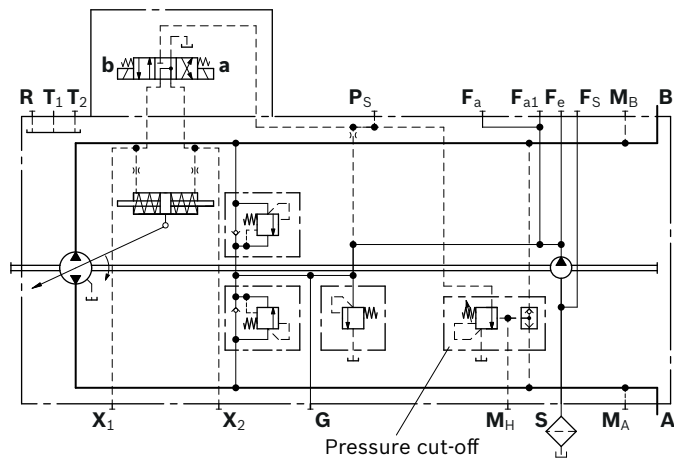

Mechanical stroke limiter

The mechanical stroke limiter is an auxiliary function allowing the maximum displacement of the pump to be steplessly reduced, regardless of the control module used.

By means of two threaded pins, the stroke of the stroking piston and thus the maximum swivel angle of the pump can be limited.

Dimensions

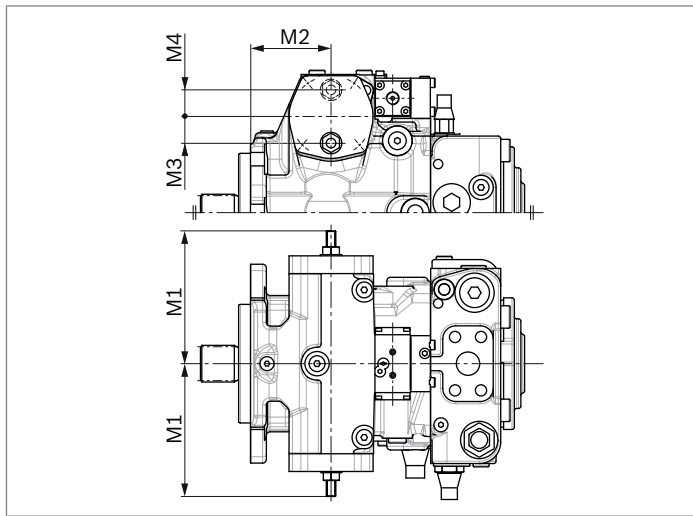

NG	M1 max	M2	M3	M4
28	110.6	40.1	24	-
40	110.6	38.1	24	-
56	130.5	44	25.5	-
71	135.4	86.3	-	28.5
90	147	95.7	31.5	-
125	173.7	104.5	-	35.5
180	182.3	138.7	38	-

▼ Circuit diagram¹⁾

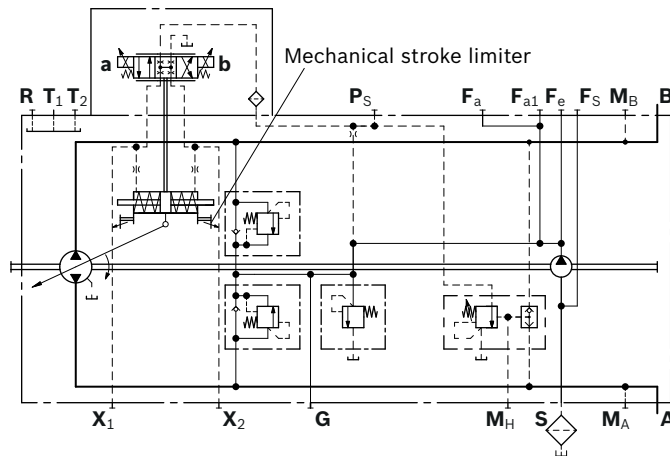

1) Size 28 without port F_{a1} and F_s

Stroking chamber pressure port X₃ and X₄

Dimensions

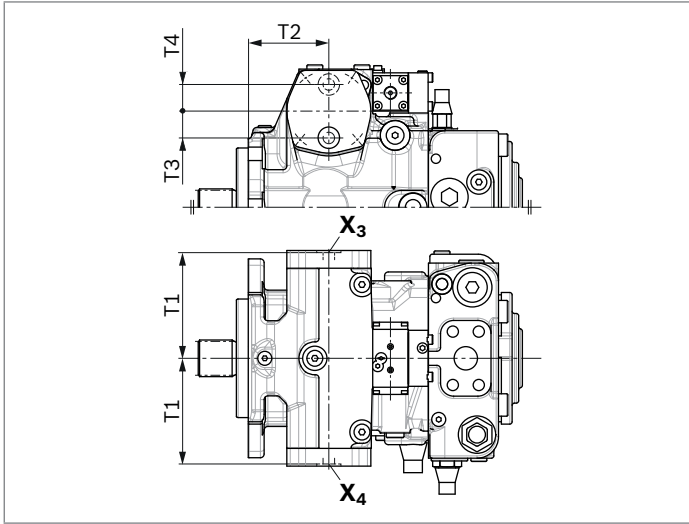

NG	T1	T2	T3	T4
28	92	40.1	-	24
40	92	38.1	-	24
56	104.5	44	-	25
71	113.5	86.3	28	-
90	111.5	95.7	-	30
125	136	104.5	34	-
180	146.5	138.7	-	35

▼ Circuit diagram¹⁾

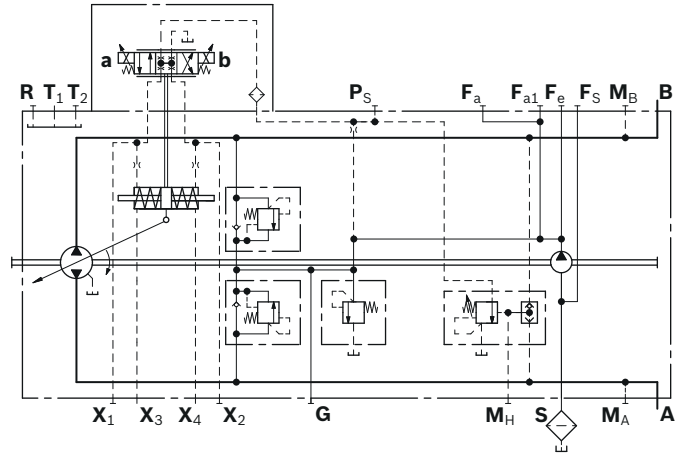

Ports	Standard ²⁾	Size	p_{max} [bar] ³⁾	State ⁴⁾
X ₃ , X ₄ Stroking chamber pressure port	DIN 3852	M12 × 1.5; 12 deep	40	X

1) Size 28 without port F_{a1} and F_s

2) The countersink can be deeper than as specified in the standard.

3) Depending on the application, momentary pressure peaks can occur. Keep this in mind when selecting measuring devices and fittings.

4) X = Plugged (in normal operation)

Filtration in the boost pump suction line

Version S

Filter version	Suction filter without bypass
Recommendation	With contamination indicator
Recommended flow resistance at filter element	
At $v = 30 \text{ mm}^2/\text{s}$, $n = n_{\text{max}}$	$\Delta p \leq 0.1 \text{ bar}$
At $v = 1000 \text{ mm}^2/\text{s}$, $n = n_{\text{max}}$	$\Delta p \leq 0.3 \text{ bar}$
Pressure at suction port S	
Continuous $p_{S \text{ min}}$ ($v \leq 30 \text{ mm}^2/\text{s}$)	$\geq 0.8 \text{ bar absolute}$
Short-term, at a cold start ($t < 3 \text{ min}$)	$\geq 0.5 \text{ bar absolute}$
Maximum pressure $p_{S \text{ max}}$	$\leq 5 \text{ bar absolute}$

Use of version S is preferred.

The suction filter is not included in the scope of delivery.

▼ Circuit diagram

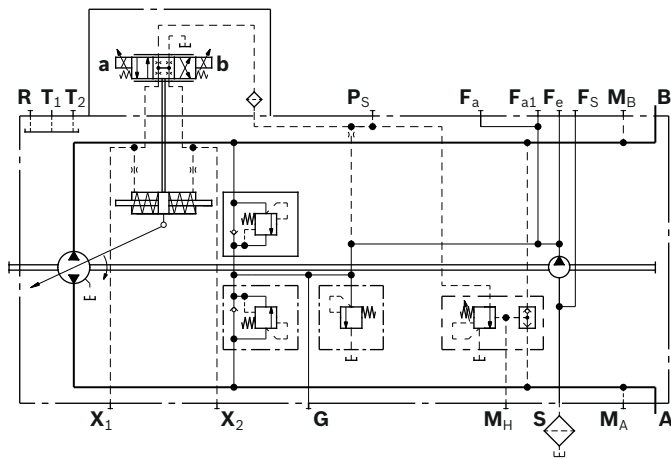

Filtration in the boost pump pressure line

Version D

Ports for external boost circuit filtration

Ports	
Boost pressure inlet	Port F_a
Boost pressure outlet	Port F_e
Filter version	Boost pressure filter without bypass
Recommendation	With contamination indicator
Filter arrangement	Separate in the pressure line (inline filter)
Permissible flow resistance at filter element ¹⁾	
At $v = 30 \text{ mm}^2/\text{s}$	$\Delta p \leq 1 \text{ bar}$
For cold start	$\Delta p \leq 3 \text{ bar}$

Notice

- Filters with a bypass **not recommended**, (exception DG, see below). Please contact us for applications with a bypass.
- On versions with DG control (with pilot pressure not from a boost circuit), a filter **with** a bypass and **with** a contamination indicator must be used.

The boost pressure filter is not included in the scope of delivery.

▼ Circuit diagram

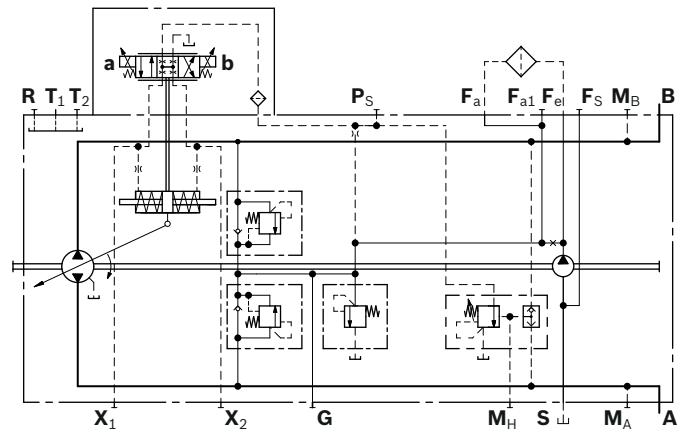

1) Valid for entire speed range n_{min} to n_{max}

Version F³⁾

Attachment filter with cold start valve

Filter version	Attachment filter without bypass
Recommendation	Version with contamination indicator, see P, B (differential pressure $\Delta p = 5$ bar)
Filter grade (absolute)	20 μm
Filter material	Glass fiber
Pressure rating	100 bar
Filter arrangement	Mounted on pump

The attachment filter is equipped with a cold start valve and thereby protects the pump from damage. The valve opens at flow resistance of $\Delta p \geq 6$ bar.

▼ Filter characteristics

Differential pressure/flow characteristics to ISO 3968 (valid for clean filter element).

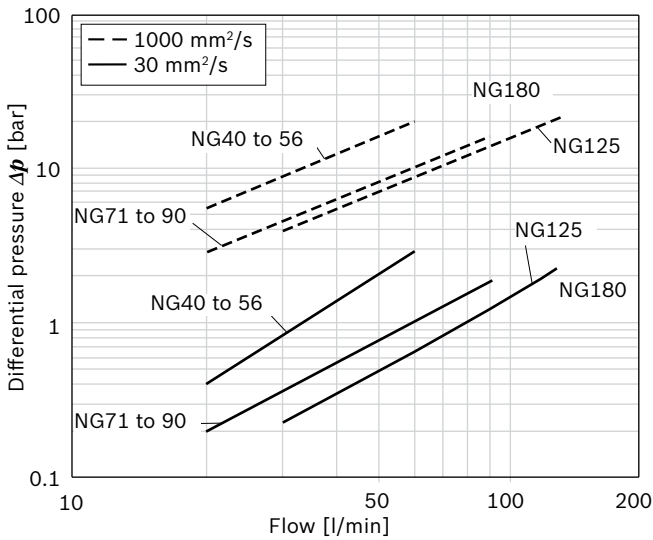

▼ Circuit diagram

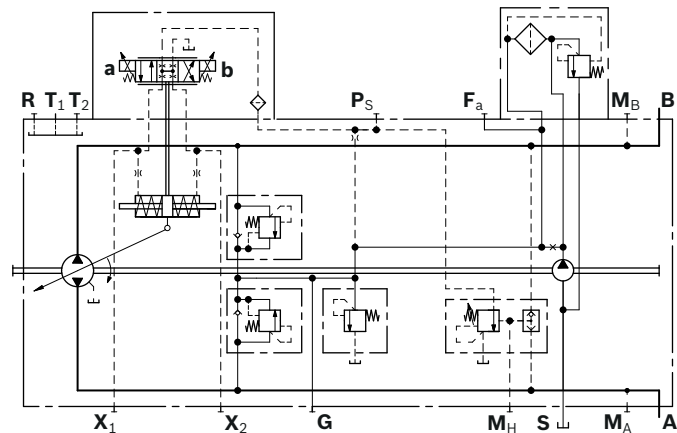

Version P¹⁾

Attachment filter with cold start valve and visual contamination indicator

Filtration similar to version F, however with additional visual contamination indicator.

Technical data	
Display type	Green/red window
Differential pressure (switching pressure)	$\Delta p = 5$ bar

▼ Circuit diagram

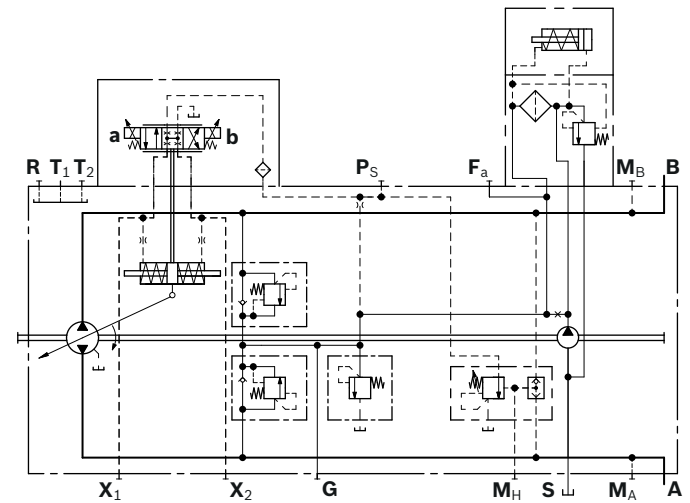

1) Valid for entire speed range $n_{\min} - n_{\max}$

2) Thread according to DIN 3852;

The countersink may be deeper than specified in the standard.

3) To protect the filter element against electrostatic charge, the hydraulic fluid must have a minimum conductivity of 300 pS/m on versions with attachment filter F, P and B. Please contact us if this value cannot be observed.

Version B¹⁾

Attachment filter with cold start valve and electric contamination indicator

Filtration similar to version F, however with additional electric contamination indicator.

Technical data

Display type	Electrical	
Connector version (mating connector, see page 68)	DEUTSCH DT04-2P-EP04	
Differential pressure (switching pressure)	$\Delta p = 5 \text{ bar}$	
Maximum switching capacity	12 V DC	24 W
	24 V DC	48 W
Type of protection IP67	DIN EN 60529	

▼ **Circuit diagram**

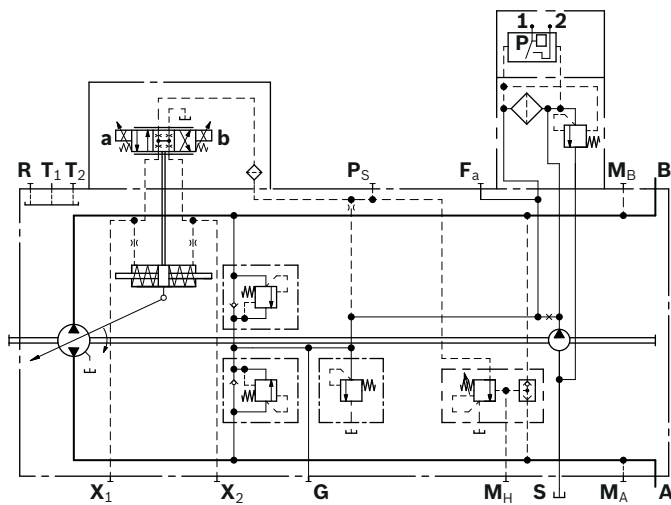

External boost pressure supply

Version E

This variation should be used in versions without integrated boost pump (**N** and **K**).

Port **S** is plugged.

The boost pressure supply comes from port **F_a**.

The filter should be installed separately on port **F_a** before the boost pressure supply.

To ensure the functional reliability, maintain the required cleanliness level for the boost fluid fed in at port **F_a** (see page 6).

▼ **Circuit diagram**

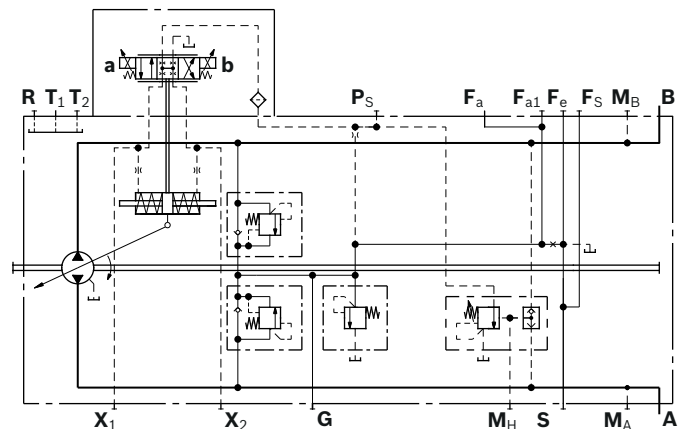

1) To protect the filter element against electrostatic charge buildup, the hydraulic fluid must have a minimum conductivity of 300 pS/m on versions with attachment filter F, P and B. Please contact us if this value cannot be observed.

Dimensions with filter fitted

▼ **Version F**

Attachment filter with cold start valve

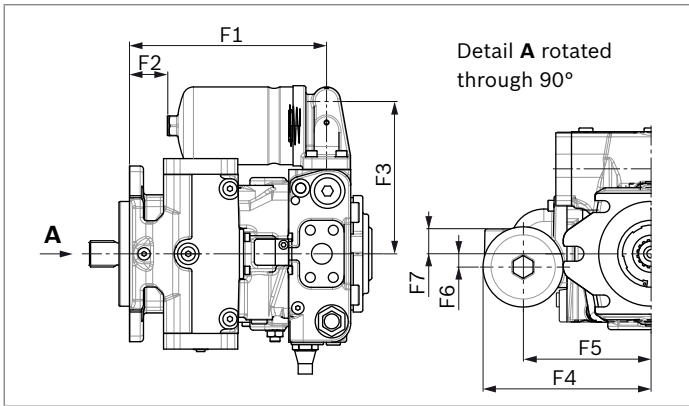

NG	F1	F2	F3	F4	F5	F6	F7	F8
40	201.7	47.7	160	175	135	0	42	78.5
56	218.4	64.4	163	178	138	0	42	78.5
71	239	46.5	185	203.5	155	16	29	65.5
90	248.5	56	179	197.5	149	0	45	81.5
125	235.9	59.4	201	219.5	171	0	53	89.5
180	279.9	40.3	202	220.4	171.9	17	36	72.5

▼ **Version P**

Attachment filter with cold start valve and visual contamination indicator

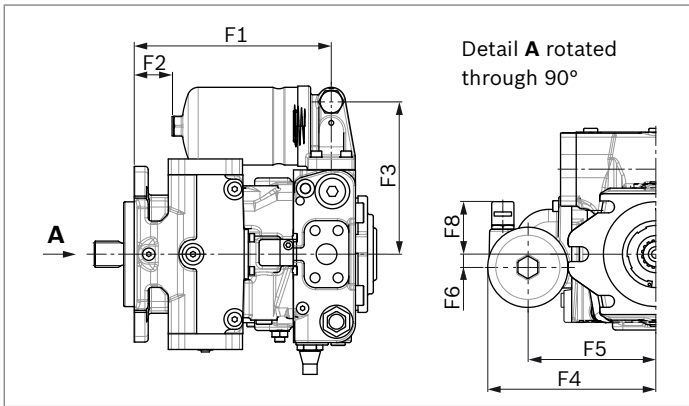

▼ **Version B**

Attachment filter with cold start valve and electric contamination indicator

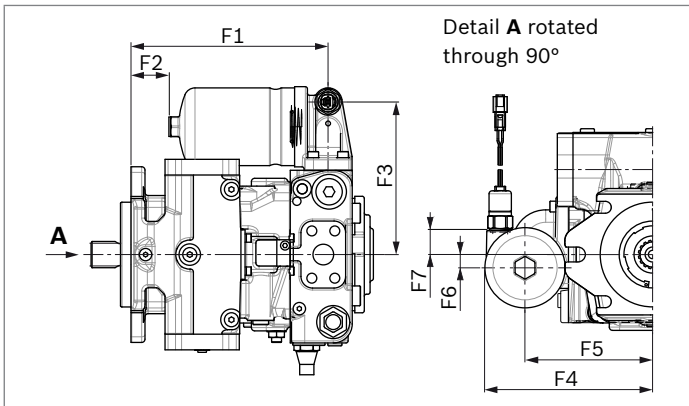

Swivel angle sensor

The swivel angle sensor is used to detect the swivel angle of axial piston units and thus the displacement using a Hall-effect based sensor IC. The determined measurement value is converted into an analog signal.

Please contact us if the swivel angle sensor is used for control.

Characteristics	
Supply voltage U_b	10 to 30 V DC
Output voltage U_a	0.5 V $(V_{g \max})$ 2.5 V $(V_{g 0})$ 4.5 V $(V_{g \max})$
Reverse polarity protection	Short-circuit resistant
EMC resistance	Details on request
Operating temperature range	-40 °C to +115 °C
Vibration resistance, sinusoidal vibration EN 60068-2-6	10 g / 5 to 2000 Hz
Shock resistance: continuous shock IEC 68-2-29	25 g
Salt spray resistance (DIN 50 021-SS)	96 h
Type of protection with installed mating connector	IP67 – DIN/EN 60529 IP69K – DIN 40050-9
Housing material	Plastic
Connector version	AMP Super Seal 1.5

Output voltage

Direction of rotation	Flow direction	Working pressure	Output voltage	
			at $V_{g 0}$	at $V_{g \max}$
clockwise	A to B	M_B	2.5 V	4.5 V
	B to A	M_A	2.5 V	0.5 V
counter-clockwise	B to A	M_A	2.5 V	4.5 V
	A to B	M_B	2.5 V	0.5 V

▼ Circuit diagram

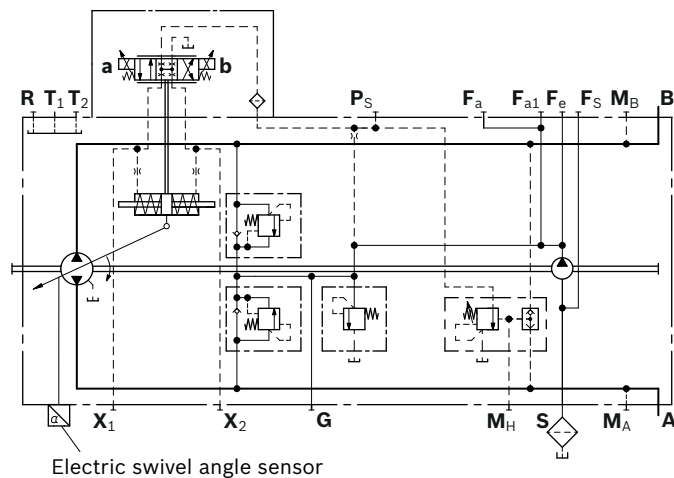

Dimensions

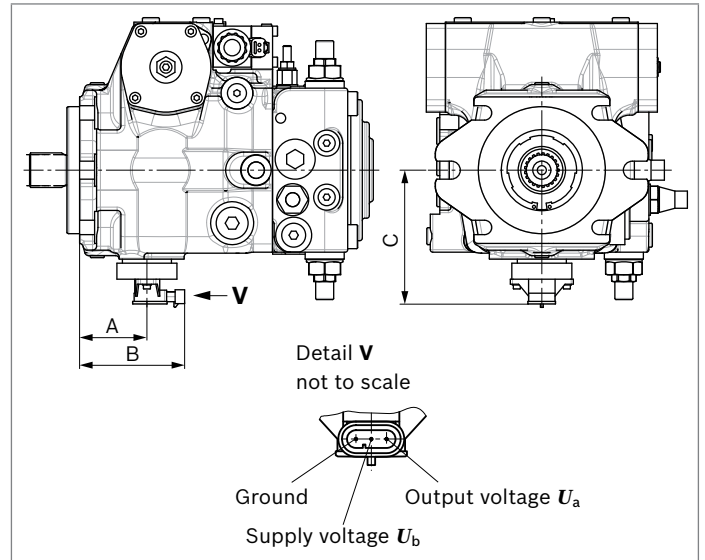

NG	A	B	C
28	56.6	94	119
40	58.6	96	119
56	60.5	97.5	128.5
71	71.6	108.6	137.5
90	70.7	107.7	145.5
125	78	115	152.5
180	100.7	137.7	153.5

Mating connector AMP Superseal 1.5; 3-pin

Consisting of	AMP No.
1 socket housing, 3-pin	282087-1
3 single-wire seals, yellow	281934-2
3 socket contacts 1.8 - 3.3 mm	183025-1

The mating connector is not included in the scope of delivery. This can be supplied by Bosch Rexroth on request (material number R902602132).

Notice

It is not possible to retrofit existing units with a swivel angle sensor.

Connector for solenoids

DEUTSCH DT04-2P-EP04

- ▶ **P:** Molded, 2-pin, without bidirectional suppressor diode (standard).
- ▶ **Q:** Molded, 2-pin, with bidirectional suppressor diode (only for switching solenoids on control module EZ and DA)

The following type of protection ensues with the installed mating connector:

- ▶ IP67 (DIN/EN 60529) and
- ▶ IP69K (DIN 40050-9)

The protection circuit with bidirectional suppressor diode is needed to limit overvoltages. Overvoltages are caused by switching off the current with switches, relay contacts or by disconnecting the mating connector while voltage is applied.

▼ Switching symbol

Without bidirectional suppressor diode

With bidirectional suppressor diode



▼ Mating connector DEUTSCH DT06-2S-EP04

Consisting of	DT designation
1 housing	DT06-2S-EP04
1 wedge	W2S
2 sockets	0462-201-16141

The mating connector is not included in the scope of delivery. This can be supplied by Bosch Rexroth on request (material number R902601804).

Notice

- ▶ If necessary, you can change the position of the connector by turning the solenoid.
- ▶ The procedure is defined in the instruction manual.

Rotary inch valve

Any reduction of the pilot pressure possible, independently of the drive speed, through mechanical actuation of the position lever. Maximum angle of rotation 90°, lever position: any. The valve is arranged separately from the pump and is connected to the pump by a hydraulic control line via port **P_S** (maximum line length: approx. 2 m). The rotary inch valve must be ordered separately.

NG	Material number	Direction of actuation of the position lever	Throttle cross-section \varnothing
28, 40,	R902048734	Clockwise	4.6
56, 71,	R902048735	Counter-clockwise	4.6
90	R902070172	Clockwise	2.7
	R902066994	Counter-clockwise	2.7
125	R902048740	Clockwise	4.7
	R902048741	Counter-clockwise	4.7

Notice

The rotary inch valve can be used regardless of the control module.

▼ **Circuit diagram:**

**Hydraulic control, speed-related,
DA with separately attached rotary inch valve**

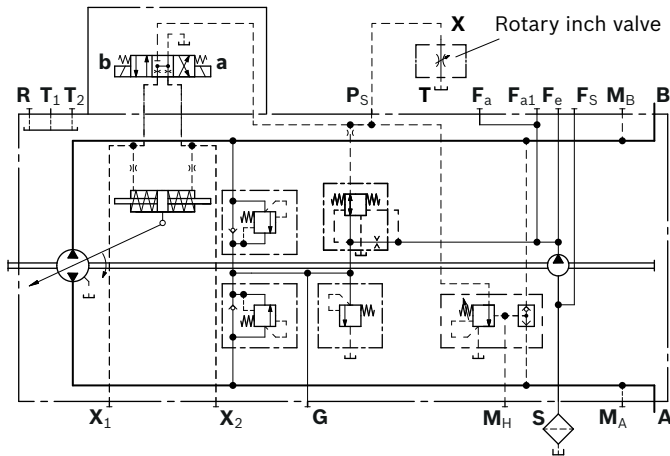

Dimensions

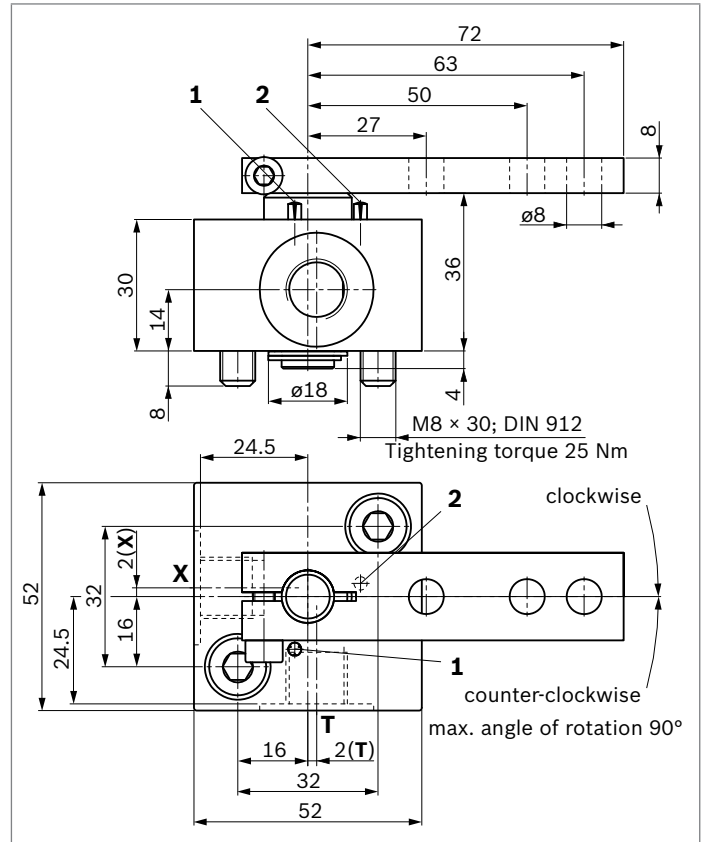

Notice

Limitation 1 and 2 are function stops for inching. They are not to be used as a mechanical limitation within the system. We recommend limiting the angle of rotation to 85° within the system.

Ports		Standard ¹⁾	Size	p_{max} [bar] ²⁾	State ³⁾
X	Pilot pressure port	DIN 3852	M14 x 1.5; 12 deep	40	O
T	Drain port	DIN 3852	M14 x 1.5; 12 deep	3	O

1) The countersink can be deeper than as specified in the standard.
2) Depending on the application, momentary pressure peaks can occur. Keep this in mind when selecting measuring devices and fittings.

3) O = Must be connected (plugged on delivery)

Installation dimensions for coupling assembly

To ensure that rotating components (coupling hub on drive shaft) and fixed components (housing, snap ring) do not come into contact with each other, the installation conditions described here must be observed. This depends on the pump size and the splined shaft.

SAE splined shaft (spline according to ANSI B92.1a)

Splined shaft **S** or **T**

The outer diameter of the coupling hub must be smaller than the inner diameter of the snap ring (dimension d_2) in the area near the drive shaft collar (dimension $x_2 - x_3$).

Observe diameter of relief on sizes 28 and 40.

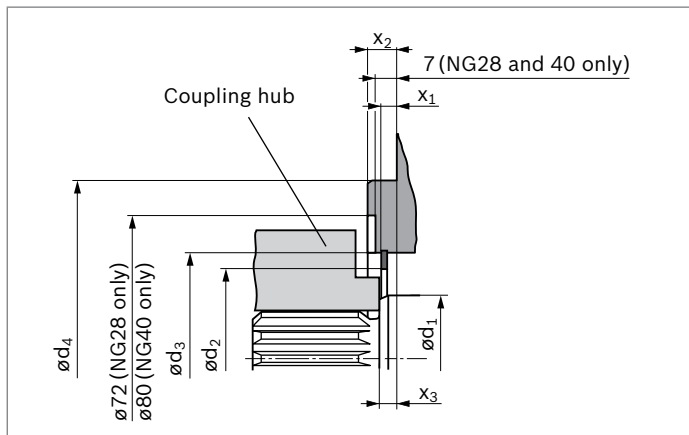

DIN splined shaft (spline according to DIN 5480)

Splined shaft **Z** or **A**

The outer diameter of the coupling hub must be smaller than the case diameter d_3 in the area near the drive shaft collar (dimension $x_2 - x_4$).

Observe diameter of relief on sizes 28 and 40.

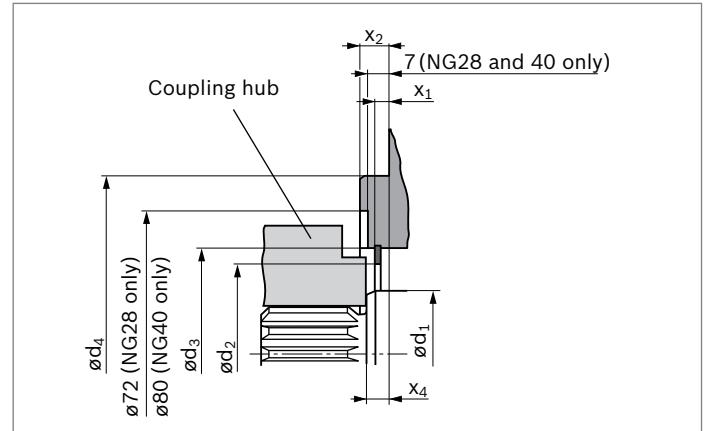

NG	$\text{ø}d_1$	$\text{ø}d_{2 \text{ min}}$	$\text{ø}d_3$	$\text{ø}d_4$	x_1	x_2	x_3	x_4
28	35	43.4	55±0.1	101.6	3.3 ^{+0.2}	9.5 _{-0.5}	8 ^{+0.9} _{-0.6}	10 ^{+0.9} _{-0.6}
40	40	51.4	63±0.1	127	4.3 ^{+0.2}	12.7 _{-0.5}	8 ^{+0.9} _{-0.6}	10 ^{+0.9} _{-0.6}
56	40	54.4	68±0.1	127	7.0 ^{+0.2}	12.7 _{-0.5}	8 ^{+0.9} _{-0.6}	10 ^{+0.9} _{-0.6}
71	45	66.5	81±0.1	127	7.0 ^{+0.2}	12.7 _{-0.5}	8 ^{+0.9} _{-0.6}	10 ^{+0.9} _{-0.6}
90	50	66.5	81±0.1	152.4	6.8 ^{+0.2}	12.7 _{-0.5}	8 ^{+0.9} _{-0.6}	10 ^{+0.9} _{-0.6}
125	55	76.3	91±0.1	152.4	7.0 ^{+0.2}	12.7 _{-0.5}	8 ^{+0.9} _{-0.6}	10 ^{+0.9} _{-0.6}
180	60	88	107±0.1	165.1	7.4 ^{+0.2}	15.9 _{-0.5}	8 ^{+0.9} _{-0.6}	10 ^{+0.9} _{-0.6}

Installation instructions

General

The axial piston unit must be filled with hydraulic fluid and air bled during commissioning and operation. This must also be observed following a longer standstill as the axial piston unit may empty via the hydraulic lines.

Particularly in the installation position “drive shaft upwards”, filling and air bleeding must be carried out completely as there is, for example, a danger of dry running. The leakage in the housing area must be directed to the reservoir via the highest drain port (**T₁**, **T₂**). For combination pumps, the leakage must be drained off at each pump. If a shared drain line is used for several units, make sure that the respective case pressure is not exceeded. The shared drain line must be dimensioned to ensure that the maximum permissible case pressure of all connected units is not exceeded in any operating conditions, specifically on cold start. If this is not possible, separate drain lines must be laid if necessary.

To achieve favorable noise values, decouple all connecting lines using elastic elements and avoid above-reservoir installation.

Under all operating conditions, the suction line and drain line must flow into the reservoir below the minimum fluid level. The permissible suction height h_s results from the overall loss of pressure. However, it must not be higher than $h_{s \max} = 800 \text{ mm}$.

The suction pressure at port **S** must also not fall below the minimum value of 0.8 bar absolute during operation (cold start 0.5 bar absolute).

Installation position

See the following examples 1 to 12.

Further installation positions are available upon request.

Recommended installation position: 1 and 2.

Notice

- ▶ Size 71 to 180
For installation position “drive shaft upward”, an **R₁** port is needed (special version).
- ▶ If filling the stroking chambers via **X₁** to **X₄** is not possible in the final installation position, then this must take place before installation, e. g. in installation position 2.
- ▶ To prevent unexpected actuation and damage, the stroking chambers must be air bled via the ports **X₁**, **X₂**, or **X₃**, **X₄** depending on the installation position.
- ▶ In certain installation positions, an influence on the control characteristic can be expected. Gravity, dead weight and case pressure can cause minor shifts in control characteristic curves and changes in response time.

Below-reservoir installation (standard)

Below-reservoir installation means that the axial piston unit is installed outside of the reservoir and below the minimum fluid level of the reservoir.

Installation position	Air bleeding the housing	Air bleeding the stroking chamber	Filling
1	R	X ₁ , X ₂	S + T ₁ + X ₁ + X ₂

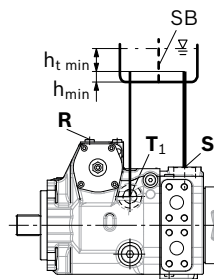

2	-	-	S + T ₂
---	---	---	--------------------

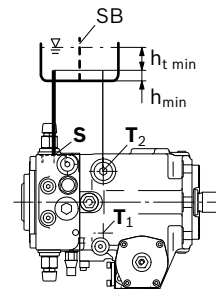

Installation position	Air bleeding the housing	Air bleeding the stroking chamber	Filling
3	-	X_1, X_2	$S + T_2 + X_1 + X_2$

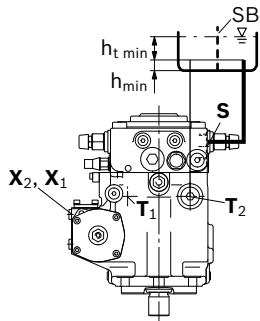

4	R_1	X_3, X_4	$S + T_2 + X_3 + X_4$
---	-------	------------	-----------------------

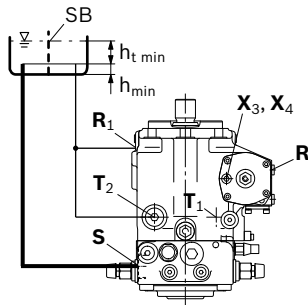

5	-	X_3	$S + T_1 + X_3$
---	---	-------	-----------------

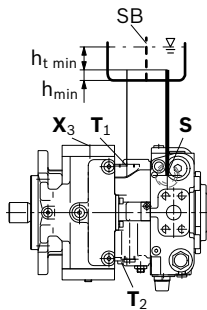

6	-	X_4	$S + T_2 + X_4$
---	---	-------	-----------------

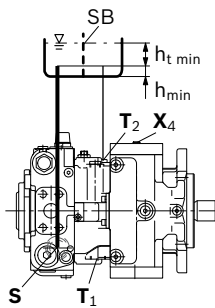

Above-reservoir installation

Above-reservoir installation means that the axial piston unit is installed above the minimum fluid level of the reservoir.

Observe the maximum permissible suction height $h_{S \max} = 800 \text{ mm}$.

Recommendation for installation position 10 (drive shaft upward): A check valve in the drain line (cracking pressure 0.5 bar) can prevent the housing area from draining.

Installation position	Air bleeding the housing	Air bleeding the stroking chamber	Filling
7	$F_2 + R$	X_1, X_2	$F_1 + F_2 + X_1 + X_2$

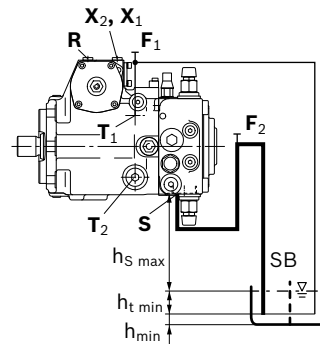

8	$F_2 (S) + F_1 (T_2)$	-	$F_2 (S) + F_1 (T_2)$
---	-----------------------	---	-----------------------

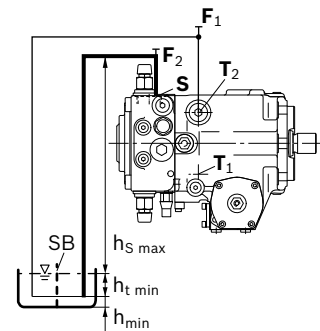

9	$F_2 (S) + F_1 (T_2)$	X_1, X_2	$F_2 (S) + F_1 (T_2) + X_1 + X_2$
---	-----------------------	------------	-----------------------------------

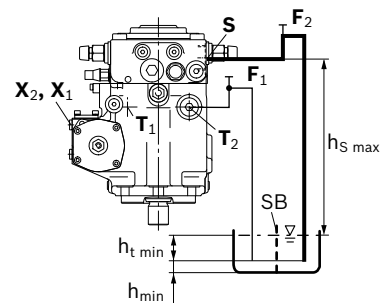

Installation position	Air bleeding the housing	Air bleeding the stroking chamber	Filling
10	$F_2 + R_1$	X_3, X_4	$F_1 + F_2 + X_3 + X_4$

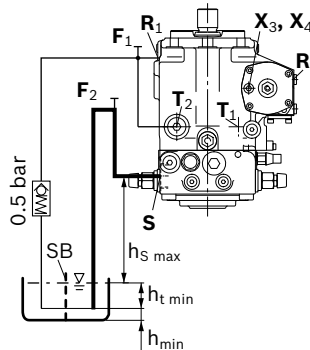

11	$F_2 (S) + F_1 (T_1)$	X_3	$F_2 (S) + F_1 (T_1) + X_3$
-----------	-----------------------	-------	-----------------------------

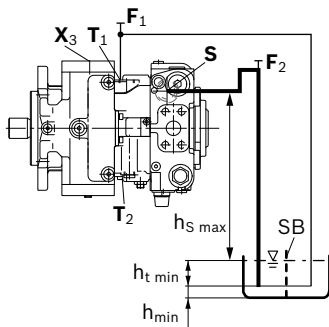

12	$F_2 (S) + F_1 (T_2)$	X_4	$F_2 (S) + F_1 (T_2) + X_4$
-----------	-----------------------	-------	-----------------------------

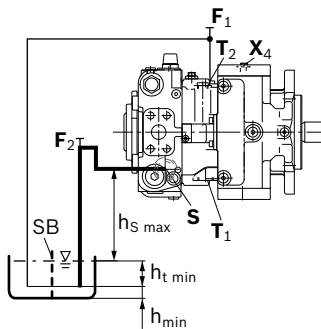

Key	
F_1, F_2	Filling / air bleeding
R	Air bleed port
R_1	Air bleed port (special version)
S	Suction port
T_1, T_2	Drain port
X_1, X_2	Control pressure port
X_3, X_4	Stroking chamber pressure port
SB	Baffle (baffle plate)
$h_{t \min}$	Minimum required immersion depth (200 mm)
h_{\min}	Minimum required distance to reservoir bottom (100 mm)
$h_{s \max}$	Maximum permissible suction height (800 mm)

Notice

Ports F_1 and F_2 are part of the external piping and must be provided on the customer side to make filling and air bleeding easier.

Project planning notes

- ▶ The pump A4VG is designed to be used in closed circuit.
- ▶ The project planning, installation and commissioning of the axial piston unit requires the involvement of qualified skilled personnel.
- ▶ Before using the axial piston unit, please read the corresponding instruction manual completely and thoroughly. If necessary, these can be requested from Bosch Rexroth.
- ▶ Before finalizing your design, please request a binding installation drawing.
- ▶ The specified data and notes contained herein must be observed.
- ▶ Depending on the operating conditions of the axial piston unit (working pressure, fluid temperature), the characteristic curve may shift.
- ▶ Preservation: Our axial piston units are supplied as standard with preservative protection for a maximum of 12 months. If longer preservative protection is required (maximum 24 months), please specify this in plain text when placing your order. The preservation periods apply under optimal storage conditions, details of which can be found in the data sheet 90312 or the instruction manual.
- ▶ Not all versions of the product are approved for use in a safety function according to ISO 13849. Please consult the responsible contact person at Bosch Rexroth if you require reliability parameters (e.g. $MTTF_d$) for functional safety.
- ▶ Depending on the type of control used, electromagnetic effects can be produced when using solenoids. When a direct current is applied, solenoids do not cause electromagnetic interference nor is their operation impaired by electromagnetic interference.
Other behavior can result when a modulated direct current (e.g. PWM signal) is applied. Potential electromagnetic interference for persons (e.g. persons with a pacemaker) and other components must be tested by the machine manufacturer.
- ▶ The pressure cut-off is not a safeguard against pressure overload. Be sure to add a pressure relief valve to the hydraulic system.
- ▶ Please note the details regarding the tightening torques of port threads and other threaded joints in the instruction manual.
- ▶ Working ports:
 - The ports and fastening threads are designed for the specified maximum pressure. The machine or system manufacturer must ensure that the connecting elements and lines correspond to the specified application conditions (pressure, flow, hydraulic fluid, temperature) with the necessary safety factors.
 - The working ports and function ports are only intended to accommodate hydraulic lines.

Safety instructions

- ▶ During and shortly after operation, there is a risk of getting burnt on the axial piston unit and especially on the solenoids. Take appropriate safety measures (e.g. by wearing protective clothing).
- ▶ Moving parts in control equipment (e.g. valve spools) can, under certain circumstances get blocked in position as a result of contamination (e.g. impure hydraulic fluid, abrasion, or residual dirt from components). As a result, the hydraulic fluid flow and the build-up of torque in the axial piston unit can no longer respond correctly to the operator's specifications. Even the use of various filter elements (external or internal flow filter) will not rule out a fault but merely reduce the risk.
The machine/system manufacturer must test whether remedial measures are needed on the machine for the application concerned in order to set the consumer being driven to a safe position (e.g. safe stop) and if necessary to ensure it is properly implemented.
- ▶ Moving parts in high-pressure relief valves may in certain circumstances become stuck in an undefined position due to contamination (e.g. impure hydraulic fluid). This can result in restriction or loss of the load holding function in lifting winches.
The machine/system manufacturer must check whether additional measures are required on the machine for the relevant application in order to keep the load in a safe position and ensure they are properly implemented.

Bosch Rexroth AG
Mobile Applications
Glockeraustraße 4
89275 Elchingen, Germany
Tel. +49 7308 82-0
info.ma@boschrexroth.de
www.boschrexroth.com

© Bosch Rexroth AG 2016. All rights reserved, also regarding any disposal, exploitation, reproduction, editing, distribution, as well as in the event of applications for industrial property rights. The data specified within only serves to describe the product. No statements concerning a certain condition or suitability for a certain application can be derived from our information. The information given does not release the user from the obligation of own judgment and verification. It must be remembered that our products are subject to a natural process of wear and aging.