

Operator's Manual

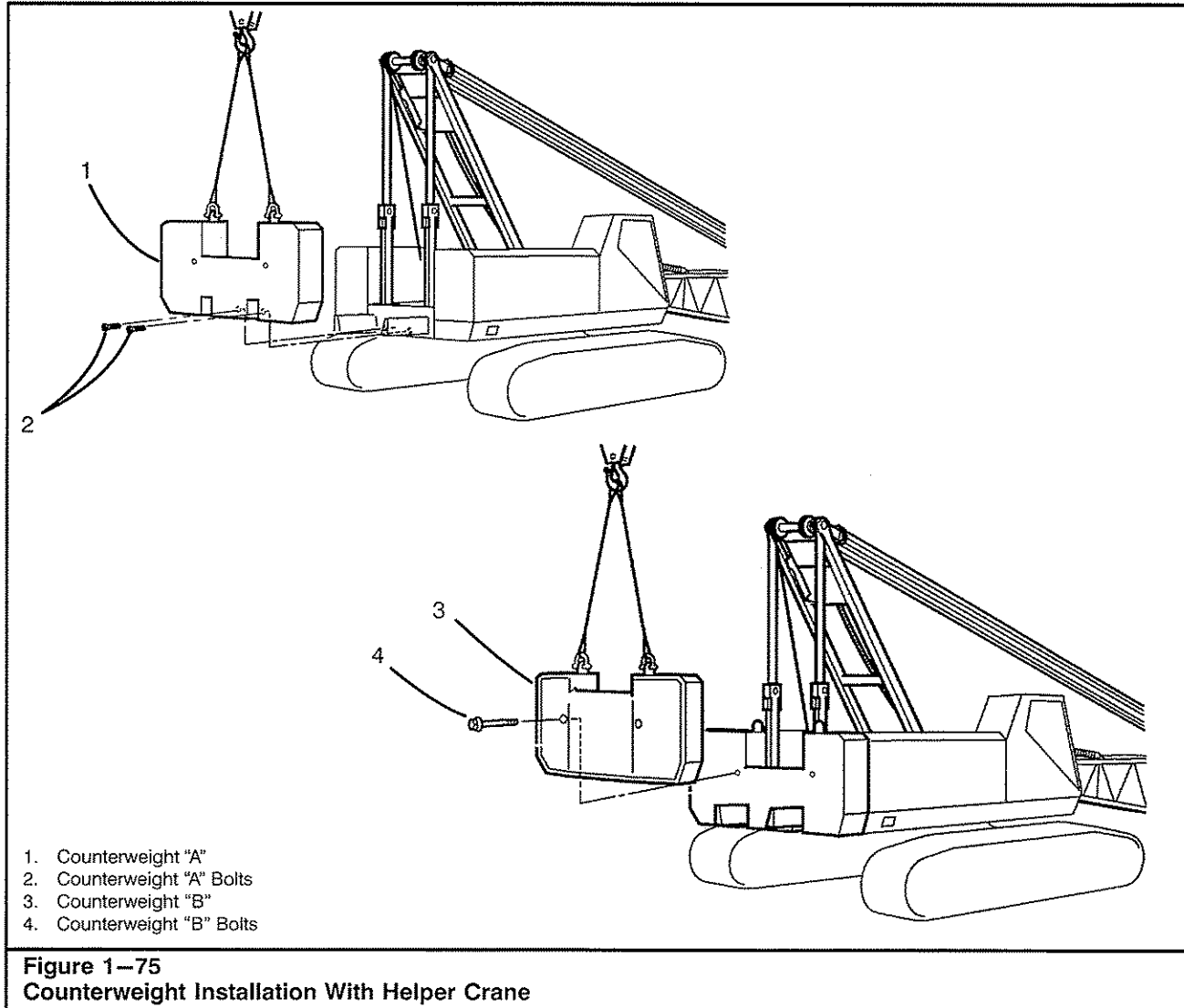

Counterweight Installation And Removal

The counterweights can be removed and installed separately by using a helper crane or by using the gantry.

Counterweight Installation With Helper Crane

Observe the following working conditions for installing and removing counterweights using a helper crane:

1. Park the crane on firm, level ground and position the upper parallel to the side frames. Engage the travel swing lock.

2. Lock the side frames in the fully extended position. Refer to "Extending And Retracting The Side Frames" in this Section of this Operator's Manual.
3. Raise the gantry to the high position. Refer to "Raising And Lowering The Gantry" in this Section of this Operator's Manual.
4. Lower boom onto secure blocking.

Note: Counterweight "A" weighs approximately 14,000 lb (6 350kg). Counterweight "B" weighs approximately 10,000 lb (4 540kg). Upper "XL" counterweight weighs approximately 4,630 lb (2 100kg). Lower "XL" counterweights weigh approximately 4,300 lb (1 950kg) each.

Operator's Manual

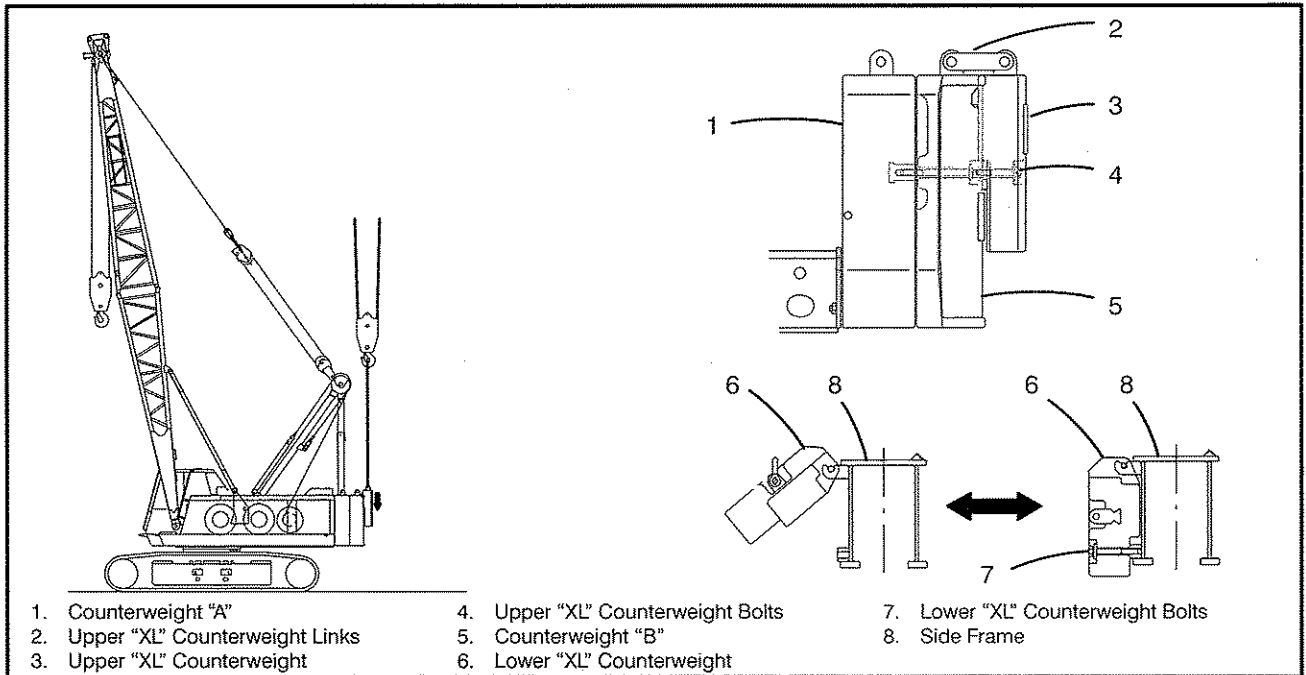

- | | | |
|-----------------------------------|-----------------------------------|-----------------------------------|
| 1. Counterweight "A" | 4. Upper "XL" Counterweight Bolts | 7. Lower "XL" Counterweight Bolts |
| 2. Upper "XL" Counterweight Links | 5. Counterweight "B" | 8. Side Frame |
| 3. Upper "XL" Counterweight | 6. Lower "XL" Counterweight | |

Figure 1-76
Upper And Lower "XL" Counterweight Installation And Removal (If Equipped)

- Use a helper crane and slings which have a sufficient capacity to lift the counterweights.

! DANGER

All personnel must stand clear while lifting the counterweight(s) into position. Serious personal injury may result.

! WARNING

Do not swing the crane, with the counterweight(s) installed, with the side frames retracted. The crane may tip over resulting in serious personal injury and/or major crane damage.

- Connect slings to counterweight "A". Refer to Figure 1-75.
- Position counterweight "A" onto the upper frame.

CAUTION

Do not bump the hook block/hook ball or slings on the helper crane against the end of the gantry. Major damage may occur.

! WARNING

Hold the counterweight with the helper crane until it is completely mounted on the crane. The counterweight could fall resulting in serious personal injury and/or major crane damage.

- Install the two counterweight "A" bolts through the counterweight "A" and into the upper frame. Properly torque the bolts.
- Remove the slings from counterweight "A".
- If counterweight "B" is to be installed, attach slings to counterweight "B".
- Lift counterweight "B" and position it with counterweight "A".
- Secure counterweight "B" to counterweight "A" by installing two counterweight "B" bolts through counterweight "B" and into counterweight "A". Properly torque the bolts.

Note: If installing the upper "XL" counterweight, use the connecting bolts supplied with the upper "XL" counterweight to secure the counterweight "B" to the counterweight "A". This allows the upper "XL" counterweight bolts to be installed through the upper "XL" counterweight and into the counterweight "B".

- Remove the slings from counterweight "B".

Operator's Manual

14. If upper "XL" counterweight is to be installed, attach slings to the upper "XL" counterweight. Refer to Figure 1-76.
15. Lift upper "XL" counterweight and position it with counterweight "B".
16. Install the two upper "XL" counterweight bolts through the upper "XL" counterweight and into the counterweight "B". Properly torque the bolts.
17. Install the upper "XL" counterweight links to connect upper "XL" counterweight to counterweight "B".
18. Remove the slings from upper "XL" counterweight.
19. If required, install the lower "XL" counterweights. Refer to Figure 1-76. Attach slings to a lower "XL" counterweight. Lift and position it on the hooks on the side frame. Lower it into position and install two lower "XL" counterweight bolts through the lower "XL" counterweight and into the side frame. Properly torque the bolts.
20. Repeat Step 19 for the lower "XL" counterweight on the other side.

Counterweight Removal With Helper Crane

1. Park the crane on firm, level ground and position the upper parallel to the side frames. Engage the travel swing lock.
2. Lock the side frames in the fully extended position. Refer to "Extending And Retracting The Side Frames" in this Section of this Operator's Manual.

Note: Counterweight "A" weighs approximately 14,000 lb (6 350kg). Counterweight "B" weighs approximately 10,000 lb (4 540kg). Upper "XL" counterweight weighs approximately 4,630 lb (2 100kg). Lower "XL" counterweights weigh approximately 4,300 lb (1 950kg) each.

3. Use a helper crane and slings which have a sufficient capacity to lift the counterweights.
4. If required, remove the lower "XL" counterweights. Refer to Figure 1-76. Attach slings to a lower "XL" counterweight. Lift until slings are tight. Remove the two lower "XL" counterweight bolts. Lift the lower "XL" counterweight up and off the hooks on the side frame. Set the lower "XL" counterweight down on a firm, level surface. Remove the slings from the lower "XL" counterweight.
5. Repeat Step 4 for the lower "XL" counterweight on the other side.
6. Raise the gantry to the high position. Refer to "Raising And Lowering The Gantry" in this Section of this Operator's Manual.
7. Lower boom onto secure blocking.



DANGER

All personnel must stand clear while lifting the counterweight(s) into position. Serious personal injury may result.



WARNING

Do not swing the crane, with the counterweight(s) installed, with the side frames retracted. The crane may tip over resulting in serious personal injury and/or major crane damage.

CAUTION

Do not bump the hook block/hook ball or slings on the helper crane against the end of the gantry. Major damage may occur.

8. If removing the upper "XL" counterweight, connect slings to the upper "XL" counterweight. Lift until slings are tight.
9. Remove the upper "XL" counterweight links that connect the upper "XL" counterweight to the counterweight "B". Properly store the links.
10. Remove the upper "XL" counterweight bolts from the upper "XL" counterweight. Properly store the bolts.
11. Lift the upper "XL" counterweight away from the counterweight "B" and set it down on a firm, level surface. Remove the slings from the upper "XL" counterweight.
12. If removing counterweight "B", connect slings to counterweight "B". Lift until slings are tight.
13. Remove the two counterweight "B" bolts that attach counterweight "B" to counterweight "A". Properly store the bolts.
14. Lift counterweight "B" away from counterweight "A" and set it down on a firm, level surface.
15. Remove the slings from counterweight "B".
16. If removing counterweight "A" connect slings to counterweight "A". Lift until slings are tight.
17. Remove the two counterweight "A" bolts that attach counterweight "A" to the upper frame. Properly store the bolts.
18. Lift counterweight "A" off the upper frame and set it down on a firm, level surface.
19. Remove the slings from counterweight "A".

Operator's Manual

Counterweight Installation Without Helper Crane

1. Park the crane on firm, level ground and position the upper parallel to the side frames. Engage the travel swing lock.
2. Install the basic boom or the base section with 20 or 30 ft (6.1 or 9.1m) of extensions.
3. Raise the gantry to the high position. Refer to "Raising And Lowering The Gantry" in this Section of this Operator's Manual.

CAUTION

The boom base section with 20 or 30 ft (6.1 or 9.1m) of extensions or the basic boom must be installed on the crane to install/remove counterweight(s). If using extensions without the top section, the bridle must be connected to the handling links on the base section, otherwise boom damage may occur.

4. If using extensions without the top section, connect the bridle to the handling links on the base section. Refer to Figure 1-77.

Note: Counterweight "A" weighs approximately 14,000 lb (6 350kg). Counterweight "B" weighs approximately 10,000 lb (4 540kg). Upper "XL" counterweight weighs approximately 4,630 lb (2 100kg). Lower "XL" counterweights weigh approximately 4,300 lb (1 950kg) each.



DANGER

All personnel must stand clear while lifting the counterweight(s) into position. Serious personal injury may result.



WARNING

Do not swing the crane, with the counterweight(s) installed and the side frames retracted. The crane may tip over resulting in serious personal injury and/or major crane damage.

Refer to Figure 1-78 for Steps 5 through 21.

5. Position the crane and/or counterweight so counterweight "A" is approximately 5.3 ft (1.62m) from the rear of the track shoes so it can be lifted straight up with the wire rope slings on the counterweight installation/removal cylinders.

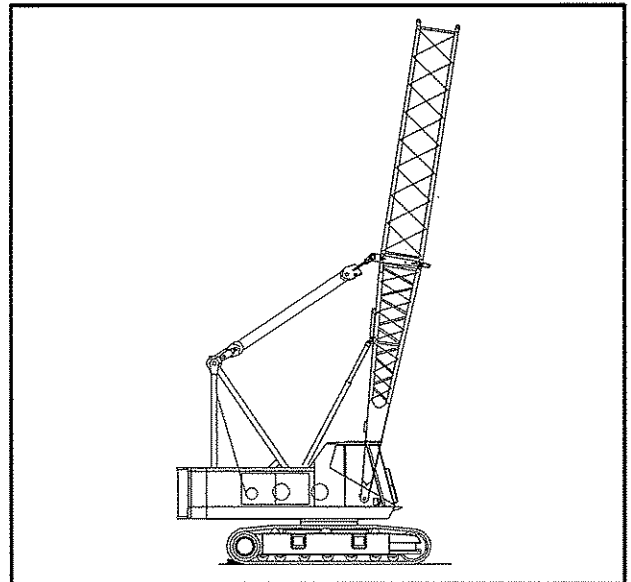

Figure 1-77
Bridle/Spreader Connection

6. Block under the idler sprockets or drive sprockets (whichever end is under the rear of the upper) to prevent the crane from rocking backwards when booming up to 81 degrees. Use the wedged blocking supplied with the crane for this purpose. Refer to "Wedged Blocking (For Over End Blocked Lifting)" in this Section of this Operator's Manual and follow the procedure except, place the wedged blocking under the rear vs. the front of the upper.
7. Boom up to 81 degree boom angle. Remove the backstop pins from the storage lugs and install them in the backstops. Secure with the lock pins.

CAUTION

Do not boom up with the gantry pinned in the raised position and the boom hoist wire ropes tight while the backstops are pinned in place. The boom backstops will be bent.

8. Remove the wire rope slings from the storage lugs on the gantry.
9. Remove the backstay pins from the gantry.
10. Move the counterweight installation/removal cylinder control lever to the "DOWN" position and extend the cylinders to their stroke end.
11. Move the boom hoist control lever to the lowering position to lower the gantry.
12. Connect the wire rope slings on the counterweight installation/removal cylinders to counterweight "A".
13. Move the counterweight installation/removal cylinder control lever to the "UP" position to fully retract the cylinders and lift counterweight "A".

Operator's Manual

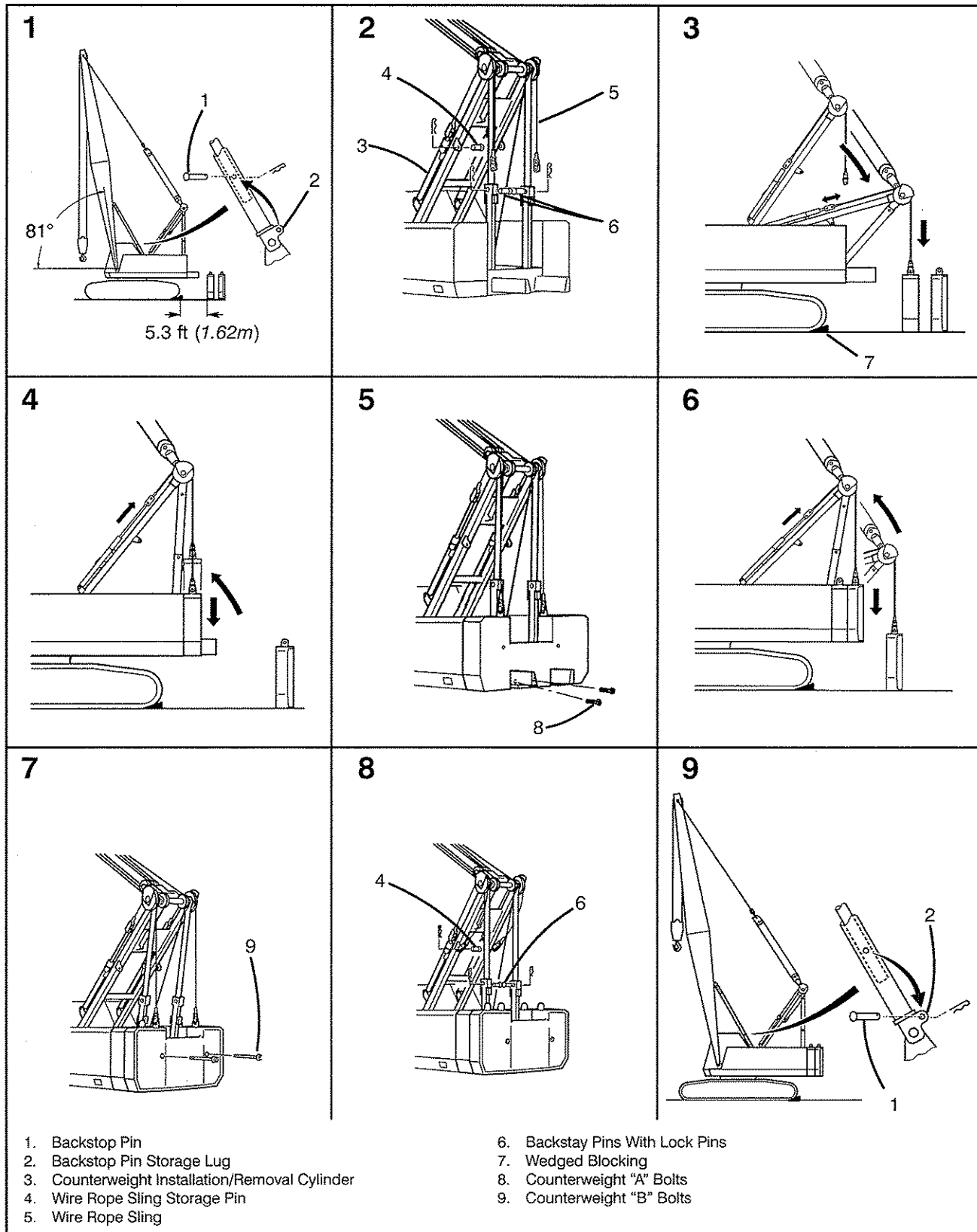

- 1. Backstop Pin
- 2. Backstop Pin Storage Lug
- 3. Counterweight Installation/Removal Cylinder
- 4. Wire Rope Sling Storage Pin
- 5. Wire Rope Sling

- 6. Backstay Pins With Lock Pins
- 7. Wedged Blocking
- 8. Counterweight "A" Bolts
- 9. Counterweight "B" Bolts

Figure 1-78
Counterweight Installation Without Helper Crane

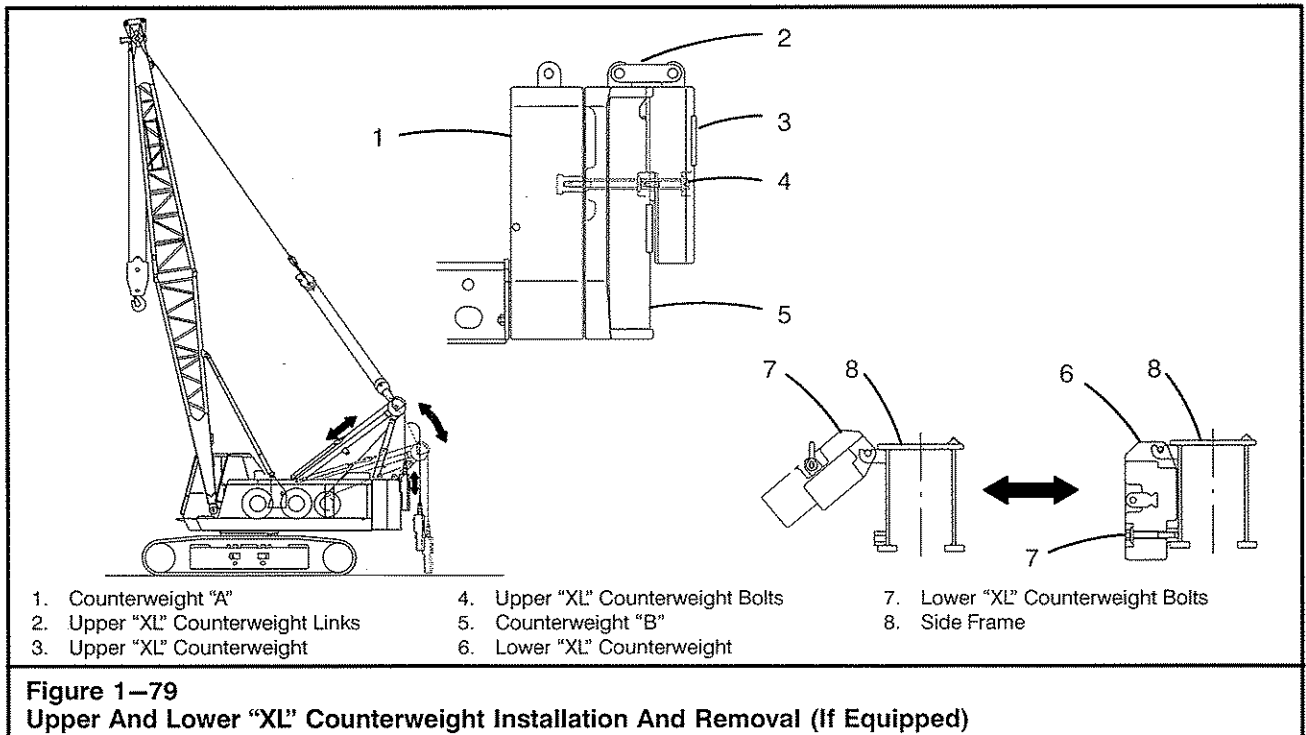

14. Move the boom hoist control lever to the hoist position to lift counterweight "A" into position. Move the counterweight installation/removal cylinder control lever to the "DOWN" position to extend the cylinders and position counterweight "A" on the upper frame.
 15. Install the two counterweight "A" bolts through the counterweight "A" and into the upper frame. Properly torque the bolts.
 16. Remove the wire rope slings from counterweight "A". If not installing counterweight "B" go to Step 28.
 17. If installing counterweight "B", remove wedged blocking and travel the crane so the distance from counterweight "B" and the rear of the track shoes is approximately 5.3 ft (1.62m) and it can be lifted straight up with the wire rope slings on the counterweight installation/removal cylinders.
 18. Repeat Step 6 and install wedged blocking.
 19. Repeat Steps 10-14 for installing counterweight "B". (Replace the references to counterweight "A" with counterweight "B" as applicable.)
- Note: If installing the upper "XL" counterweight, use the connecting bolts supplied with the upper "XL" counterweight to secure the counterweight "B" to the counterweight "A". This allows the upper "XL" counterweight bolts to be installed through the upper "XL" counterweight and into the counterweight "B".**
20. Secure counterweight "B" to counterweight "A" with the counterweight "B" bolts through counterweight "B" and into counterweight "A". Properly torque the bolts.
 21. Remove the wire rope slings from counterweight "B". If not installing upper "XL" counterweight, go to Step 28.
 22. If installing upper "XL" counterweight, remove wedged blocking and travel the crane so the distance from the upper "XL" counterweight and the rear of the track shoes is approximately 5.3 ft (1.62m) and it can be lifted straight up with the wire rope slings on the counterweight installation/removal cylinders.
 23. Repeat Step 6 and install wedged blocking.
 24. Repeat Steps 10-14 for installing upper "XL" counterweight. Refer to Figure 1-79. (Replace the references to counterweight "A" with upper "XL" counterweight as applicable.)
 25. Install the two upper "XL" counterweight bolts through the upper "XL" counterweight and into the counterweight "B". Properly torque the bolts.
 26. Install the upper "XL" counterweight links to connect the top of upper "XL" counterweight to the top of counterweight "B".
 27. Remove the wire rope slings from the upper "XL" counterweight.

Operator's Manual

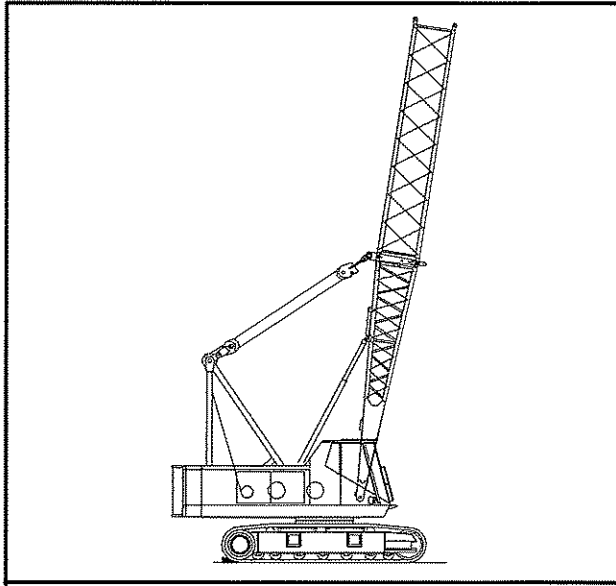

Figure 1–80
Bridle/Spreader Connection

28. Raise/lower the gantry as required and pin it in the high position with the backstay pins. Secure with lock pins. Refer to Figure 1–78.

CAUTION

Do not boom up with the gantry pinned in the raised position and the boom hoist wire ropes tight while the backstops are pinned in place. The boom backstops will be bent.

CAUTION

Backstay pins must be installed to hold gantry in position for all load lifting operations.

29. Store the wire rope slings on the gantry lugs.

Note: If the crane/boom has rocked backwards, the boom may be resting on the backstop pins making them difficult to remove. Do not boom up to attempt to remove the pins. Travel the crane forward to a position of slightly downward slope to allow the boom to rock forward or pull the boom forward to free and remove the pins.

30. Remove the backstop pins from the backstops and store in the backstop pin storage lugs on the backstops.

31. If required, install the lower “XL” counterweights. Refer to Figure 1–79. Attach slings to a lower “XL” counterweight. Lift with an auxiliary lifting device and position it on the hooks on the side frame. Lower it into position and install two lower “XL” counterweight bolts through the lower “XL” counterweight and into the side frame. Properly torque the bolts. Remove the slings from the lower “XL” counterweight.
32. Repeat Step 31 for the lower “XL” counterweight on the other side.

Counterweight Removal Without Helper Crane

1. Park the crane on firm, level ground and position the upper parallel to the side frames. Engage the travel swing lock.
2. Install the basic boom or the base section with 20 or 30 ft (6.1 or 9.1m) of extensions.
3. Raise the gantry to the high position. Refer to “Raising And Lowering The Gantry” in this Section of this Operator’s Manual.

CAUTION

The boom base section with 20 or 30 ft (6.1 or 9.1m) of extensions or the basic boom must be installed on the crane to install/remove counterweight(s). If using extensions without the top section, the bridle must be connected to the handling links on the base section, otherwise boom damage may occur.

4. If using extensions without the top section, connect the bridle to the handling links on the base section. Refer to Figure 1–80.

Note: Counterweight “A” weighs approximately 14,000 lb (6 350kg). “Counterweight B” weighs approximately 10,000 lb (4 540kg). Upper “XL” counterweight weighs approximately 4,630 lb (2 100kg). Lower “XL” counterweights weigh approximately 4,300 lb (1 950kg) each.



DANGER

All personnel must stand clear while lifting the counterweight(s) into position. Serious personal injury may result.

Operator's Manual



WARNING

Do not swing the crane, with the counterweight(s) installed and the side frames retracted. The crane may tip over resulting in serious personal injury and/or major crane damage.

5. Block under the idler sprockets or drive sprockets (whichever end is under the rear of the upper) to prevent the crane from rocking backwards when booming up to 81 degrees. Use the wedged blocking supplied with the crane for this purpose. Refer to "Wedged Blocking (For Over End Blocked Lifting)" in this Section of this Operator's Manual and follow the procedure except, place the wedged blocking under the rear vs. the front of the upper.
6. Boom up to 81 degree boom angle. Remove the backstop pins from the backstop pin storage lugs and install them in the backstops. Secure with the lock pins. Refer to Figure 1-81.

CAUTION

Do not boom up with the gantry pinned in the raised position and the boom hoist wire ropes tight while the backstops are pinned in place. The boom backstops will be bent.

7. Remove the wire rope slings from the storage lugs on the gantry.
8. Move the counterweight installation/removal cylinder control lever to the "DOWN" position and extend the cylinders to their stroke end.
9. Remove the backstay pins from the gantry.
10. If the upper "XL" counterweight is not installed, go to Step 20.
11. If the upper "XL" counterweight is to be removed, move the boom hoist control lever to the lowering position to lower the gantry. Lower the gantry until the wire rope slings are centered over the upper "XL" counterweight. Refer to Figure 1-79.
12. Connect the wire rope slings on the counterweight installation/removal cylinders to the upper "XL" counterweight.
13. Move the counterweight installation/removal cylinder control lever to the "UP" position to retract the cylinders and take up the slack in the wire rope slings to support the upper "XL" counterweight.
14. Remove the upper "XL" counterweight links that connect upper "XL" counterweight to counterweight "B". Properly store the links.
15. Remove the two upper "XL" counterweight bolts. Properly store the bolts.

16. Move the counterweight installation/removal cylinder control lever to the "UP" position to retract the cylinders and lift the upper "XL" counterweight from the counterweight "B".
17. Move the boom hoist control lever to the lowering position to lower the gantry and upper "XL" counterweight.
18. Move the counterweight installation/removal cylinder control lever to the "DOWN" position to extend the cylinders and lower the upper "XL" counterweight to a firm level surface.
19. Remove the wire rope slings from the upper "XL" counterweight.
20. If the counterweight "B" is not to be removed, go to Step 31.
21. If counterweight "B" is to be removed, remove wedged blocking and travel the crane forward to provide clearance between counterweight "B" and upper "XL" counterweight when the counterweight "B" is removed.
22. Repeat Step 5 and install wedged blocking.
23. Move the boom hoist control lever to the hoist position to raise the gantry.

CAUTION

Do not boom up with the gantry pinned in the raised position and the boom hoist wire ropes tight while the backstops are pinned in place. The boom backstops will be bent.

24. Connect the wire rope slings on the counterweight installation/removal cylinders to counterweight "B". Refer to Figure 1-81.
25. Move the counterweight installation/removal cylinder control lever to the "UP" position to retract the cylinders and take up the slack in the wire rope slings to support the upper "B" counterweight.
26. Remove the two counterweight "B" bolts. Properly store the bolts.
27. Move the counterweight installation/removal cylinder control lever to the "UP" position to retract the cylinders and lift the counterweight "B" from counterweight "A".
28. Move the boom hoist control lever to the lowering position to lower the gantry and counterweight "B".
29. Move the counterweight installation/removal cylinder control lever to the "DOWN" position to extend the cylinders and lower counterweight "B" to a firm level surface.
30. Remove wire rope slings from counterweight "B".
31. If counterweight "A" is not to be removed, go to Step 42.

Operator's Manual

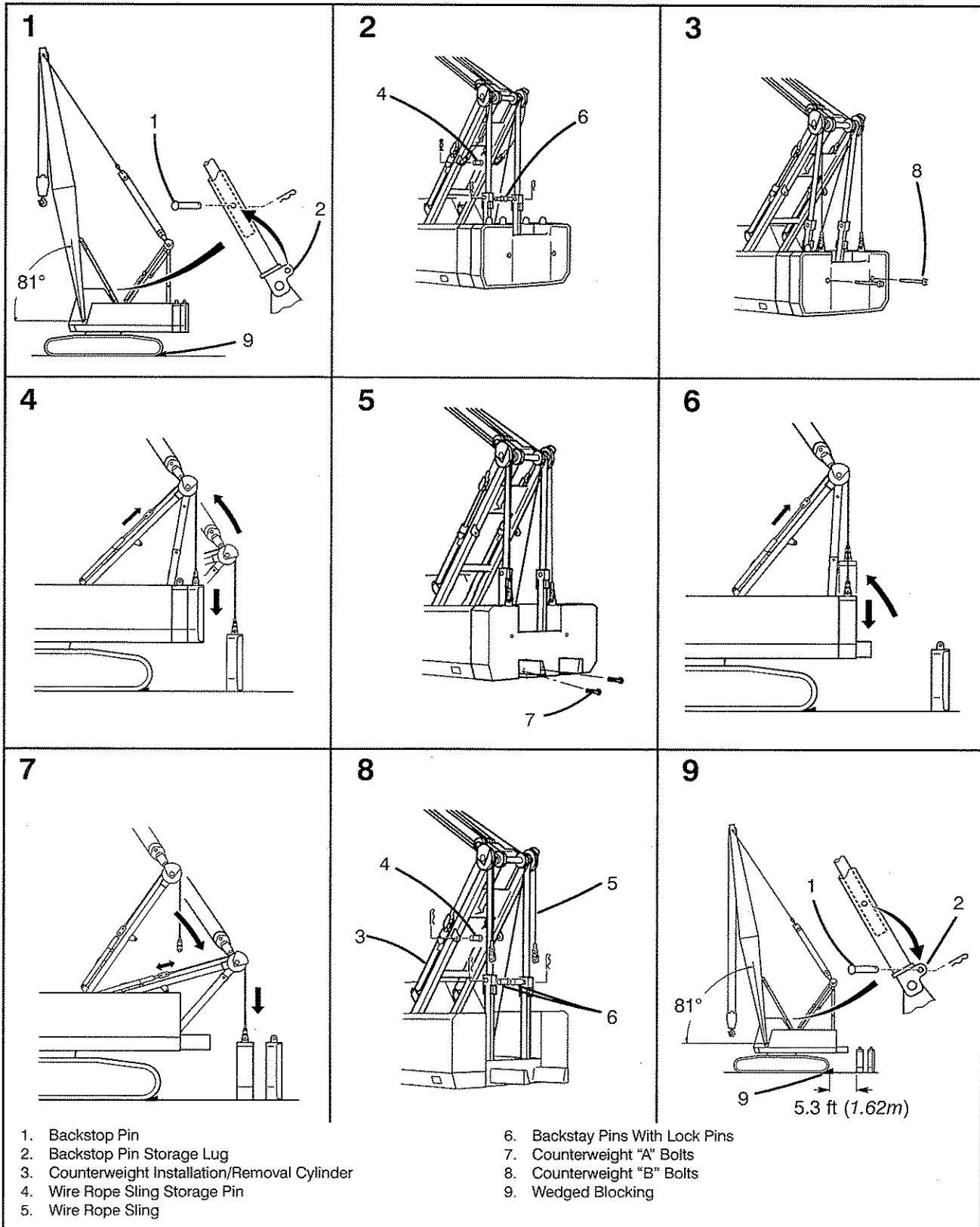

Figure 1-81
Counterweight Removal Without Helper Crane

Operator's Manual

32. If counterweight "A" is to be removed, remove wedged blocking and travel the crane forward to provide clearance between counterweight "A" and counterweight "B" when the counterweight "A" is removed.
33. Repeat Step 5 and install wedged blocking.
34. Move the boom hoist control lever to the hoist position to raise the gantry.

CAUTION

Do not boom up with the gantry pinned in the raised position and the boom hoist wire ropes tight while the backstops are pinned in place. The boom backstops will be bent.

35. Connect the wire rope slings on the counterweight installation/removal cylinders to counterweight "A". Refer to Figure 1-81.
36. Move the counterweight installation/removal cylinder control lever to the "UP" position to retract the cylinders and take up the slack in the wire rope slings to support the counterweight "A".
37. Remove the two counterweight "A" bolts. Properly store the bolts.
38. Move the counterweight installation/removal cylinder control lever to the "UP" position to retract the cylinders and lift the counterweight "A" from the upper frame.
39. Move the boom hoist control lever to the lowering position to lower the gantry and counterweight "A".
40. Move the counterweight installation/removal cylinder control lever to the "DOWN" position to extend the cylinders and lower counterweight "A" to a firm level surface.
41. Remove wire rope slings from counterweight "A".
42. Raise/lower the gantry as required and pin it in the high position with the backstay pins. Secure with lock pins. Refer to Figure 1-81.

CAUTION

Backstay pins must be installed to hold gantry in position for all load lifting operations.

43. Store the wire rope slings on the gantry lugs.

Note: If the crane has rocked backwards, the boom may be resting on the backstop pins making them difficult to remove. Do not boom up to attempt to remove the pins. Travel the crane to a position of slightly forward slope to allow the boom to rock forward or pull the boom forward before removing the pins.

44. Remove the pins from the backstops and store in the backstop pin storage lugs on the backstops.
45. If required, remove the lower "XL" counterweights. Refer to Figure 1-79. Using an auxiliary lifting device, attach slings to a lower "XL" counterweight. Lift until slings are tight. Remove the two lower "XL" counterweight bolts. Lift the lower "XL" counterweight up and off the hooks on the side frame. Set the lower "XL" counterweight down on a firm, level surface. Remove the slings from the lower "XL" counterweight.
46. Repeat Step 45 for the lower "XL" counterweight on the other side.

Operator's Manual

Extending And Retracting The Side Frames	1-94
Extending The Side Frames	1-94
Retracting The Side Frames	1-94
Raising And Lowering The Gantry	1-96
Raising The Gantry With Helper Crane	1-96
Lowering The Gantry With Helper Crane	1-97
Raising The Gantry Without Helper Crane	1-98
Lowering The Gantry Without Helper Crane	1-99
Counterweight Installation And Removal	1-100
Counterweight Installation With Helper Crane	1-100
Counterweight Removal With Helper Crane	1-102
Counterweight Installation Without Helper Crane	1-103
Counterweight Removal Without Helper Crane	1-106
Front Mounted Third Drum Winch	1-110
Wedged Blocking (For "Over End Blocked" Lifting)	1-111
Placing The Wedged Blocking	1-111
Hand Signals	1-112
Traveling The Crane	1-113
Traveling Without A Load	1-113
Traveling With A Load (Pick & Carry)	1-113
Traveling On A Slope (Without A Load Only)	1-114
Transporting The Crane	1-115
Transporting The Crane With The Base Section	1-115
Transporting The Crane With The Boom Folding System	1-115
Transporting The Boom	1-118
Crane Storage	1-120
Short Term Storage	1-120
Long Term Storage	1-120

Operator's Manual

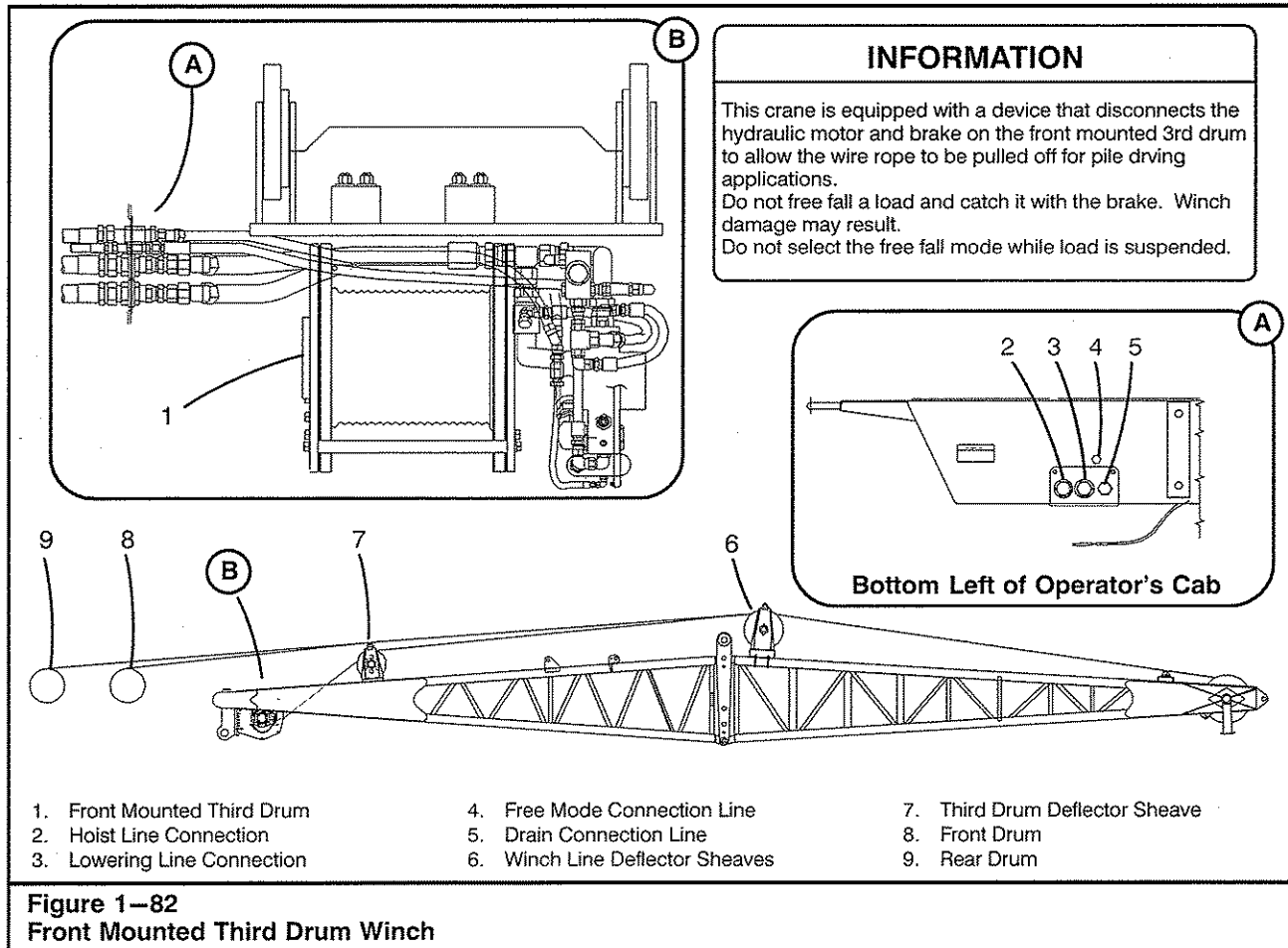

Front Mounted Third Drum Winch

A third drum may be mounted on the front of the upper frame between the boom foot pins. Refer to Figure 1-82. Although there are other applications, the front mounted third drum was added to optimize the operation of pile driving. It is used where the third drum line is reeved over the boom point and left attached to the piling as it is being driven by the hammer.

The front mounted third drum is controlled by the third drum control lever. It has two modes of operation, Automatic Brake Mode and Free Mode.



WARNING

The front mounted third drum is not equipped with a foot pedal and true free-fall as are the main winches. It cannot be used to free-fall loads. It cannot be used to lift a load unless it is in the Automatic Brake Mode.

The Automatic Brake Mode allows normal operation of the winch, which matches the front and rear winch. It is power in/power out with an automatic brake which applies when the third drum control lever is in neutral.

The Free Mode allows the automatic brake to release. In Free Mode the wire rope can be pulled off the drum with a force of approximately 500 lb (227kg).

To operate the third drum for pile driving applications:

1. With third drum in Automatic Brake Mode, attach the wire rope to the pile.
2. Using the third drum, hoist the pile into position under the hammer.
3. Move the mode switch to the Free Mode position.
4. The pile will pull wire rope off the drum as it is driven into the ground. This is advantageous to the operator because the drag on the wire rope is provided by the winch and the operator does not have to constantly watch the third drum wire rope.

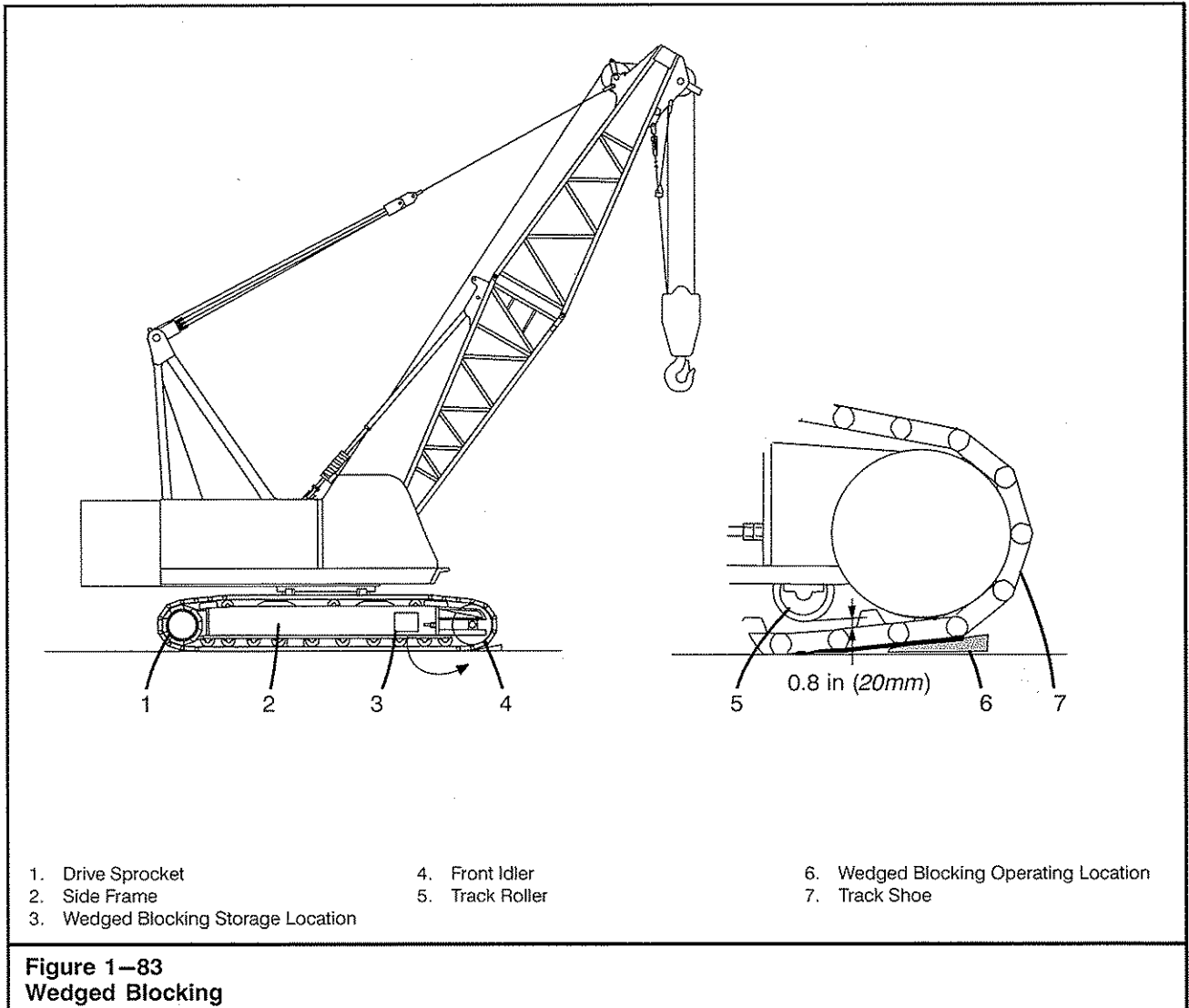

Wedged Blocking (For “Over End Blocked” Lifting)

The crane has “Over End Blocked” lifting capacities when wedged blocking is placed under the side frame sprockets or idlers to prevent rocking.

Placing The Wedged Blocking

1. Remove the wedged blocking from storage on the side frame.
2. Place the wedged blocking under the end of the tracks that the load is being lifted, as shown in Figure 1-83.

3. Drive the crane up onto the wedged blocking. Confirm that blocking is evenly positioned under the end of each side frame.

Note: The clearance between the foremost track roller and track shoe should be approximately 0.8” (20mm).



WARNING

Confirm that the faces of the wedged blocking and the track shoes contact evenly. If surfaces do not contact evenly, wedged blocking will be damaged.

Operator's Manual

Standard Hand Signals For Controlling Crane Operations

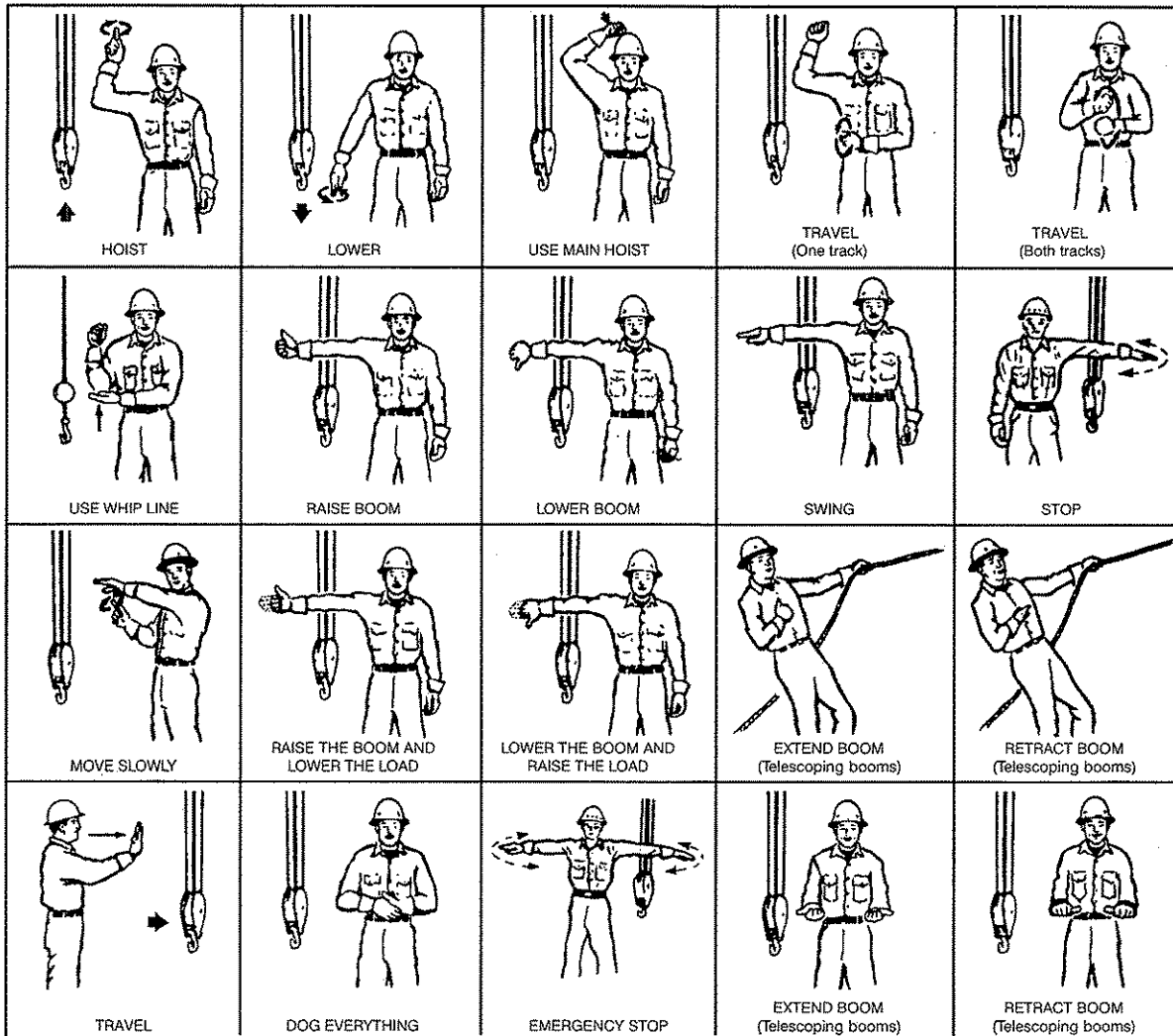

Extracted from the American National Standard, Crawler, Locomotive and Truck Cranes, ANSI B30.5b-1985, with the permission of the Publisher the American Society of Mechanical Engineers, 345 E. 47th Street, New York, New York 10017.

Figure 1-84
Hand Signals

Hand Signals

Hand signals are important for communications between the designated signal person and the operator. A Hand Signals Chart, Figure 1-84, is included in this Section of this Operator's Manual. A copy is also on the exterior of the crane.

These signals should be used at all times unless voice instructions with a radio or telephone are being used. One person should be designated as a signal person and their signals obeyed by the operator. Obey a "stop" signal from anyone.

Operator's Manual

Traveling The Crane

Certain conditions must be met for safe travel when traveling with or without a load, or when traveling on a slope. Use the following procedures when traveling the crane.

Traveling Without A Load

The crane can be traveled with all boom lengths and all boom plus jib combinations as listed in the Crane Rating Manual. Refer to the Crane Rating Manual for liftoff capability and instructions. When moving the crane around the job site with the attachment in the air, observe the following precautions for safe job site travel.

1. Terrain must be smooth and solid. If not, grade the area before moving the crane.
2. Tie down the hook block and/or hook ball to prevent it/them from swinging.
3. Position a signal person to guide you.
4. The boom must be positioned at a boom angle for which a capacity is given in the Crane Rating Manual. All other boom angles are considered out of the allowable working range of the crane and no travel is allowed.
5. The boom should be positioned over the end of the lower. Certain job site conditions will make this impossible. Travel with the boom pointed over the side will be allowed only when conditions prevent traveling with the boom straight over the end.
6. Engage the travel swing lock (upper positioned over the end) and the swing (park) brake.
7. Travel slowly and cautiously in order to avoid any shock loading on the boom, jib, or crane. Use either the high speed travel switch or pump control switch to reduce travel speed if necessary.

Traveling With A Load (Pick & Carry)

All 360 degree capacities listed in the Crane Rating Manual are pick and carry capacities. The following precautions must be followed while traveling with a load.

1. Travel with the boom pointing straight over one end of the lower. If the load was lifted over the side, swing the load over the end before starting travel.
2. Engage the travel swing lock and swing (park) brake.
3. Travel only on a smooth, level surface. If a smooth, level route is not available, don't travel with a suspended load. Grade the route to provide a smooth, level path. If it is not possible to grade the route, move the load by stepping. Park the crane on a level area, lift the load, swing around, and set it down ahead of the crane. Travel the unloaded crane beyond the load, level the crane, lift the load, swing, and set it down farther along the route. Continue this procedure until the load is at its destination.
4. Use a hand line to control the load and reduce load swing.
5. Carry loads as close to the ground as possible.
6. Do not allow side swing of load.
7. Don't attempt to carry loads which exceed the crane's rating.
8. Use a signal person to warn of any danger or obstruction along the route being traveled.
9. Don't travel with a load on soft ground. If the crane sinks into the ground, stability can be affected to the point of tipping the crane.
10. Keep all personnel clear of the crane and load. Be prepared to set the load down quickly at anytime.
11. Position the boom at a boom angle that will give the greatest margin of safety. If the load was lifted at a long radius and the load is at or near capacity for that radius, boom up to obtain a greater lifting capacity (and thus a greater margin of safety) before starting travel.
12. Travel slowly and cautiously in order to avoid shock loading on the boom, jib, or crane. Use either the high speed travel switch or pump control switch to reduce the travel speed if necessary. Do not let the load swing out or to the side. The load must be kept directly under the boom point at all times.

Operator's Manual

Traveling On A Slope (Without A Load Only)

Travel on a slope is allowed up to a grade of 30%. The following precautions must be followed.

1. When traveling on a slope, always face the upper straight over one end of the lower.
2. Engage the travel swing lock and swing (park) brake.
3. Travel straight up or down the slope with the "heavy" end of the crane facing uphill. The heavy end of the crane will normally be the counterweight end of the crane. With some long boom combinations, the boom end of the crane will be the "heavy" end. If possible, position the boom at a high enough boom angle so that the counterweight end of the crane is the "heavy" end of the crane and travel with the boom facing downhill.
4. Always travel in a slow, cautious manner when traveling on a slope. Use either the high speed travel switch or pump control switch to reduce travel speed if necessary.
5. Do not travel with a load on a slope. Major boom off lead and/or side load will result, which will greatly increase the loading into the boom structure.
6. Watch the engine service monitor. Be alert to the engine service monitor while traveling on a slope. All lamps should be off under normal operation. If an engine service monitor lamp comes on while traveling on a slope, the slope is too great for the crane to traverse. Limited travel will be allowed only to travel the crane off the slope. Continued operation with an engine service monitor light on will result in engine damage.
7. Avoid steering on a slope. Steering on a slope is not recommended. Always travel straight up or down the slope. Avoid traveling with a side to side slope. Grade the path to eliminate any side to side slope.
8. Maintain gradual approach and departure angles. Grade the top and bottom ends of a slope to form a gentle break-over angle. This will prevent the crane from lunging when the center of gravity crosses over the top of the slope.

Transporting The Crane

Transporting The Crane With The Base Section

When job site conditions or highway load limitations permit, the base section lifting link can be used to support the boom base section while traveling or transporting the crane. Refer to Figure 1–85. Use of the boom lifting link while transporting eliminates the need to remove the base section. Check local road restrictions before transporting the crane in this configuration to ensure compliance.

Transporting The Crane With The Boom Folding System

When job site conditions or highway load limitations permit, the 50 ft (15.2) or 70 ft (21.3m) boom can remain installed on the crane in a folded position and transported. Refer to Figure 1–86. Use of the boom folding system eliminates the need to disassemble the boom. Before loading the crane for transport in this configuration, refer to “Boom Folding/Unfolding System” in Section 4 of this Operator's Manual.

When transporting the crane, precautions should be taken in securing the crane to the trailer, barge, or other means of conveyance. The lower cross axles are the recommended tie down points.

CAUTION

If chains are wrapped around the cross axles, be certain the chains will not damage any lines or components.

Always exercise safety and follow all local codes when loading, unloading, or transporting the crane.

Prepare crane as follows before transporting it:

1. Properly disassemble the attachment and secure the backstops as required. Refer to Section 4 of this Operator's Manual for the correct procedures.
2. Remove the counterweights as required and retract the side frames. Refer to “Counterweight Removal And Installation” and “Extending And Retracting The Side Frames” in this Section of this Operator's Manual.
3. Place the gantry to the low position. Refer to “Raising And Lowering The Gantry” in this Section of this Operator's Manual.
4. The upper must be positioned directly over the end of the lower with the travel swing lock engaged.

Note: The base section, folded 50 ft (15.2m), or 70 ft (21.3m) boom may be left on the crane during transport, only if load limitations permit.

5. All control levers in operator's cab must be in neutral and the gate lock lever in the “Stop” position.
6. Remove the keys from the crane and lock all windows and doors.
7. Depending on the specific situations, further preparations may be needed to protect the crane from the environment or vandalism. See “Crane Storage” for further suggestions.

Operator's Manual

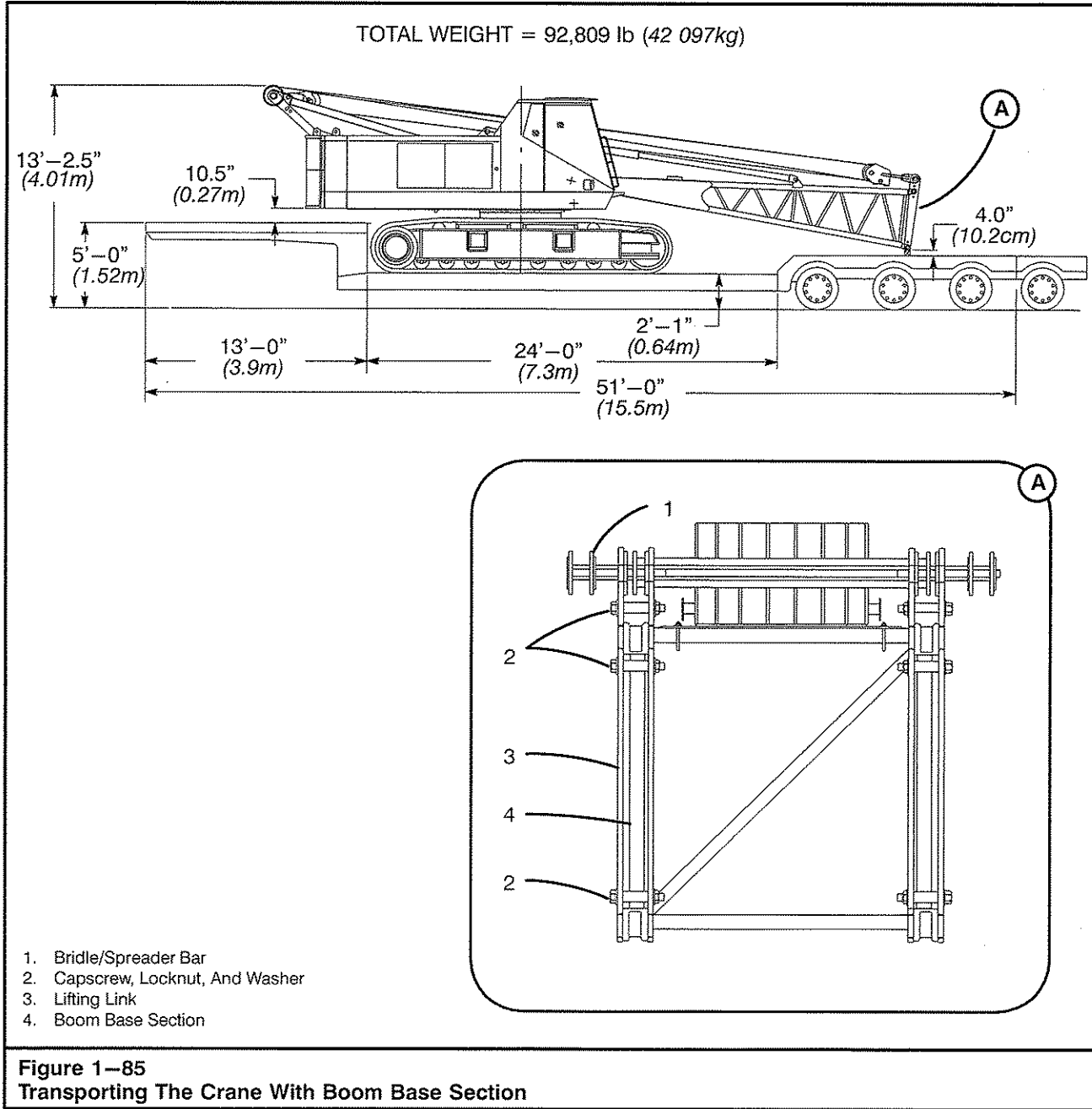

Operator's Manual

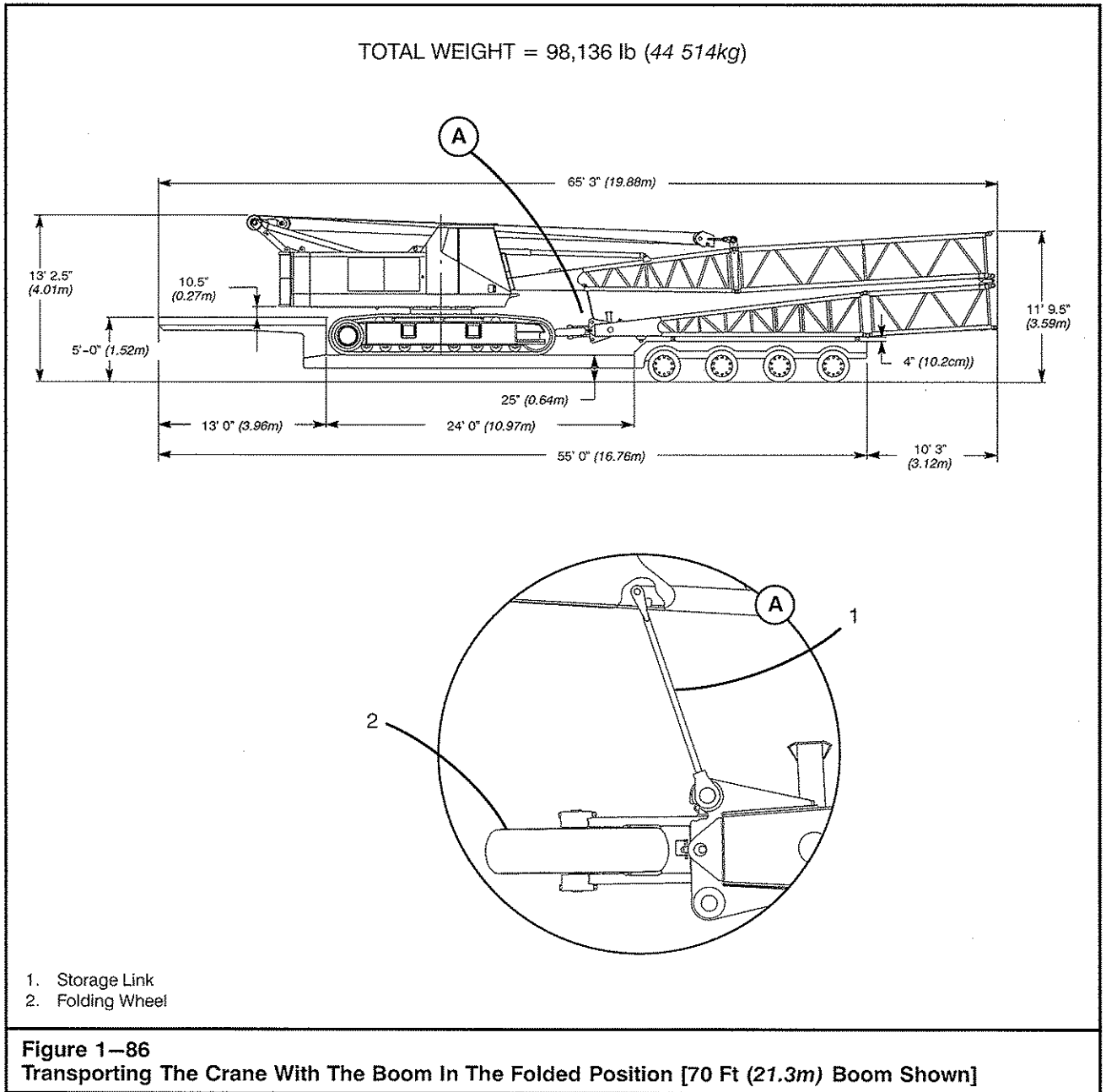

Operator's Manual

Transporting The Boom

When transporting the boom sections, precautions should be taken in securing the sections to the trailer. The following is the suggested method of boom tie-down for transport. When transporting tubular boom sections, the following conditions must be met:

CAUTION

If boom sections are improperly secured to the trailer, damage could occur which may weaken the structural integrity of the boom.

1. Do not tie down in mid span.
2. Do not strap over top of boom.
3. Secure boom to the trailer with a. or b. below:
 - a. Two 4" (10cm) nylon straps over boom chords 12–18 in (30–46cm) from both ends only.
 - b. Two chains over boom chords at both ends only. Boom chords must be protected with 1/2 in (1.3cm) (minimum) thick hard rubber strips.
4. Wood blocking should be positioned directly under the nylon straps (or chains).
5. Careful consideration should be given to the dimensions in order to prevent an initial bending condition in lattice members and chords.
6. Nylon straps must be kept very tight. Check often to confirm that straps are tight. Straps must be twisted to prevent vibration.

Attachment Weights

Component	Weight (each)		Quantity	Total	
	lb	kg		lb	kg
10 ft (3.05m) Jib Extension	190	86	3	570	259
Basic 20 ft (6.1m) Jib	1,177	534	1	1,177	534
10 ft (3.05m) Boom Extension	781	354	2	1,562	708
20 ft (6.1m) Boom Extension	1,335	605	1	1,335	606
30 ft (9.1m) Boom Extension	1,832	831	2	3,664	1 662
20 ft (6.1m) Boom Top Section	2,711	1 229	1	2,711	1 229
60T (54.4mt) 4 Sheave Hook Block	1,088	493	1	1,088	494
8.5T (7.7mt) Hook Ball	360	163	1	360	163
Basic Pendants	126	57.1	1	126	57
Total				12,593	5 712

Operator's Manual

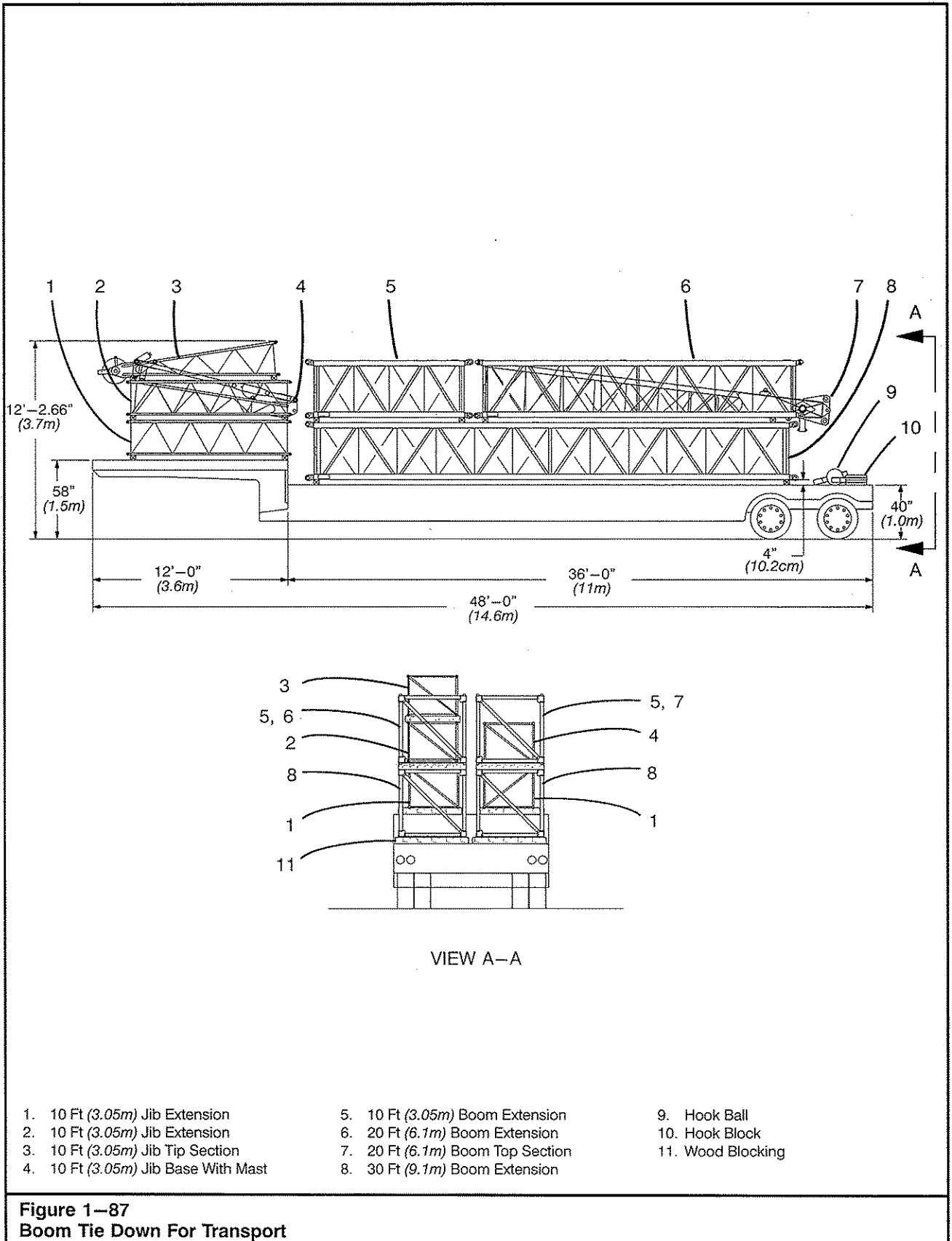

Operator's Manual

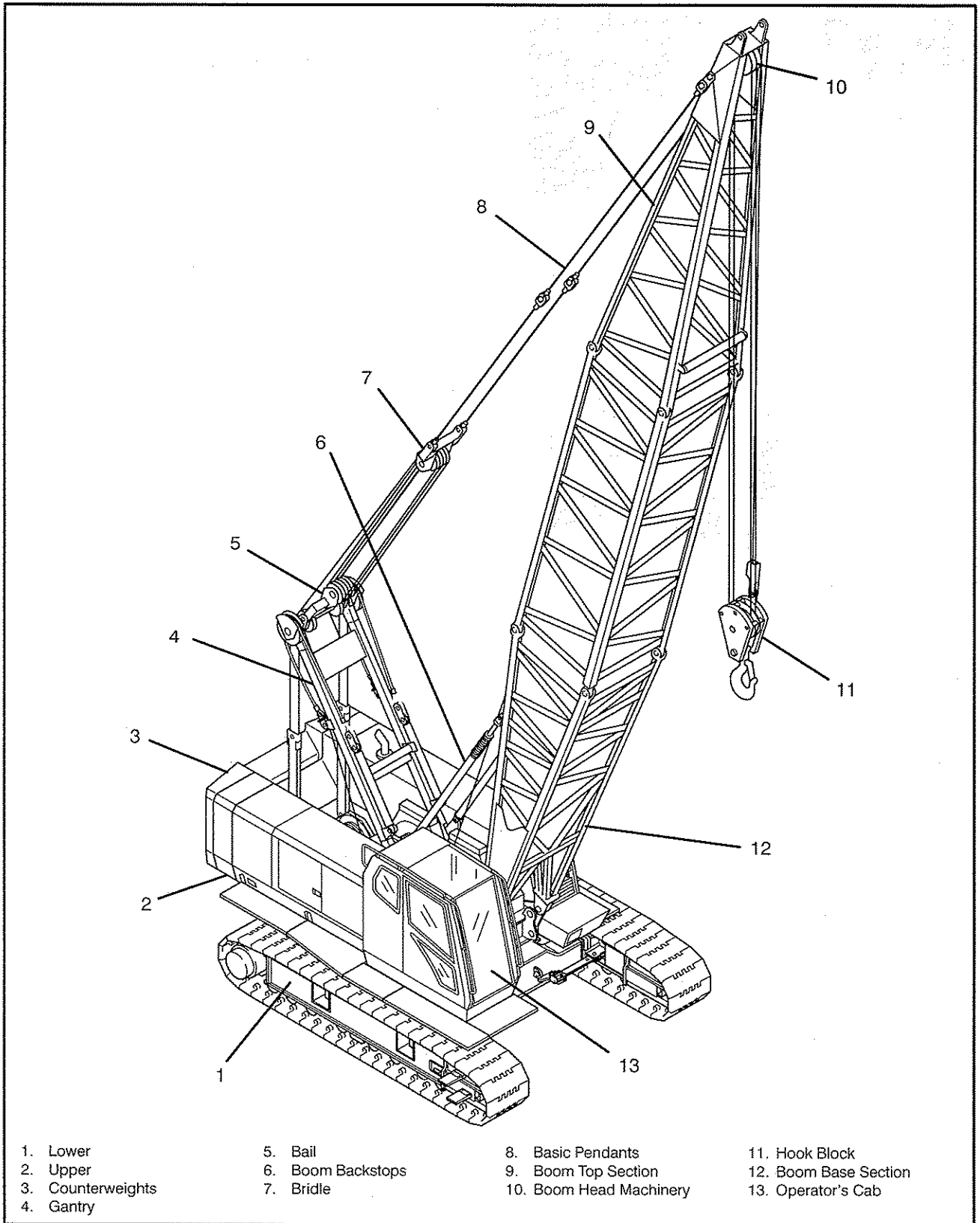

- | | | | |
|-------------------|-------------------|-------------------------|-----------------------|
| 1. Lower | 5. Bail | 8. Basic Pendants | 11. Hook Block |
| 2. Upper | 6. Boom Backstops | 9. Boom Top Section | 12. Boom Base Section |
| 3. Counterweights | 7. Bridle | 10. Boom Head Machinery | 13. Operator's Cab |
| 4. Gantry | | | |

Figure 1-1
Crane Nomenclature

Operator's Manual

Crane Storage

Any time the crane is going to be left unattended, it should be prepared so that it will not be damaged by the elements, be an attraction to vandals, or a plaything for children.

Short Term Storage

1. Do not leave crane where it will be a traffic hazard.
2. Lower all loads to the ground.
3. Position the boom at a high angle for maximum stability. The jib may be erected.
4. Confirm that both drum brake pedals are latched in the fully applied position and the boom hoist drum pawl is engaged.
5. The travel swing lock must be engaged.
6. All control levers must be in the neutral position.
7. Block the track to prevent the crane from rolling.
8. In cold weather, position the crane where it will not freeze to the ground.
9. Remove the keys from the crane and lock all windows and doors.

Long Term Storage

1. Store the crane inside a building if possible.
2. Thoroughly clean the crane.
3. Touch up any spots where paint has chipped. This will prevent rusting.
4. Lubricate the entire crane as per the Lubrication Chart. Ensure all gear cases are filled to their proper oil level.

5. If possible, block the crane up so the tracks clear the ground. Ensure the blocking is placed so the crane cannot fall off it. If this is not possible, set the crane on planks so the track will not sink in the ground. Block the track to prevent the crane from rolling.
6. Fully retract all hydraulic cylinders. Cover all cylinder rods and machined and unpainted surfaces with a coat of grease.
7. All control levers must be in the neutral position with the gate lock lever in the "Stop" position.
8. Cover all open areas around the engine, operator's cab, etc. to prevent entry of water. Cover the entire engine area with a tarp if possible.
9. Prepare the engine as per the engine manufacturer's manual. Confirm that antifreeze protection is sufficient to prevent the engine from freezing. If antifreeze protection is not adequate, completely drain the engine block.
10. If in a location where vandalism may occur, remove the keys and lock the operator's cab windows and doors. Cover all operator's cab glass with plywood or boards to prevent glass breakage. Provide a means of locking the engine access doors, fuel tank, and hydraulic reservoir.
11. Store the crane so it does not provide a plaything for children. Such a unit can be an "attractive nuisance" for children to play on. If they fall off it or get entangled, serious injury may result.
12. While in storage, the crane should be "exercised" every 60 days to ensure the working condition of the crane. Start the engine and operate all switches, control cables, and hydraulic functions several times to circulate lubricants and to keep all mechanisms and linkages operative.

Operator's Manual

Table Of Contents

General Lubrication Information	2-1
Upper Lubrication	2-2
Lower Lubrication	2-4
Attachment Lubrication	2-5
Lubricant Specifications	2-6
Hi Performance Hydraulic Oil Chart	2-7
Travel Unit Lubrication	2-8
Travel Unit Oil Level Check	2-8
Travel Unit Oil Change	2-8
Engine Air System Inspection	2-8
Engine Air Cleaner	2-9
Changing The Engine Air Cleaner Element	2-9
Cleaning The Air Cleaner Element	2-10
Washing	2-10
Compressed Air	2-10
Inspecting The Air Cleaner Element	2-10
Boom Hoist Lubrication	2-11
Boom Hoist Planetary Oil Level Check	2-11
Boom Hoist Planetary Oil Change	2-11
Front And Rear Winch Drum Lubrication	2-12
Winch Drum Gear Case Oil Level Check	2-12
Winch Drum Gear Case Oil Change	2-13
Winch Drum Planetary Oil Level Check	2-13
Winch Drum Planetary Oil Change	2-13
Front Mounted Third Drum Winch Lubrication	2-14
Third Drum Oil Level Check	2-14
Third Drum Oil Change	2-14
Fourth Drum Winch Lubrication (Braden)	2-15
Fourth Drum Oil Level Check	2-15
Fourth Drum Oil Change	2-15

Operator's Manual

Fourth Drum Winch Lubrication (HSC)	2-17
Fourth Drum Gear Case Oil Level Check	2-17
Fourth Drum Gear Case Oil Change	2-17
Fourth Drum Reduction Unit Oil Level Check	2-17
Fourth Drum Reduction Unit Oil Change	2-17
Swing Speed Reducer Lubrication	2-18
Swing Speed Reducer Oil Level Check	2-18
Swing Speed Reducer Oil Change	2-18
Hydraulic Reservoir	2-19
Water Drain	2-19
Hydraulic Reservoir Oil Level Check	2-19
Adding Oil To The Hydraulic Reservoir	2-20
Hydraulic Reservoir Oil Change	2-20
Hydraulic System Filters	2-21
Hydraulic System Pressure Filter Change	2-21
Hydraulic System Return Filter Change	2-22
Boom And Jib Inspection And Lubrication	2-23
Wire Rope Lubrication	2-23
Crane Monitoring System	2-24
Hydraulic Hose Assembly Inspection	2-24
Hook Block, Hook Ball, And Swivel Inspection And Maintenance	2-25
Lubrication Frequency	2-25
Inspection Frequency	2-25
Air Conditioning Inspection And Maintenance	2-26
Air Conditioning Filter	2-27
Compressed Air	2-27
Washing	2-27
Turntable Bearing Capscrew Torque	2-28
Paint Maintenance	2-28
Regular Preventative Maintenance	2-28
Polishing And Waxing Procedure	2-28
Operator's Cab Console Cleaning	2-28

Operator's Manual

General Lubrication Information

The crane should be regularly and systematically lubricated in accordance with the Lubrication Charts shown on the following pages. Refer to Figure 2-1, Figure 2-2, and Figure 2-3. A copy of this chart is also behind an upper, right access door. The time intervals shown on the Lubrication Charts are intended as a guide only. Under unusual working conditions, such as working in dry, dusty conditions, in water, mud, or around a corrosive atmosphere, more frequent lubrication could be necessary. In these cases, the oiler must use his best judgment and work out his own lubrication schedule.

In addition to the points on the Lubrication Chart, all movable linkages and control cables should be periodically lubricated to resist wear.

There are some very practical reasons for lubricating and lubricant changes. Lubricants serve more than one purpose. They not only lubricate, but they transport chemically reactive additives, wash away minute wear particles, serve as a corrosion inhibitor, and act as a heat transfer medium. Draining and refilling any gear unit with a fresh supply of oil also assists in eliminating wear particles not trapped by filters or magnetic plugs.



WARNING

Shutdown engine before fueling or lubricating crane. To avoid a fire hazard, do not smoke or handle fuel around an open flame. To avoid major crane damage and to prevent serious injury, do not lubricate gears or any assemblies while they are in motion.



WARNING

Lubricating oils may be hot. Use care when handling oils during checking and draining procedures.

The following procedures are important for proper lubrication of the crane:

1. Wipe the grease gun nozzle before lubricating. This will help keep dirt and grit from entering the bushing or bearing.
2. Keep all grease and oil cans and containers clean. Always replace the lid on containers when finished to prevent entry of foreign materials. Wipe off oil can covers before using.
3. Drain oil cases when hot to drain off accumulated sludge.
4. Watch for signs of incorrect lubrication such as failure of clean grease to purge the old grease.
5. Bleed off hydraulic pressure before opening or removing a line or fitting.
6. Replace all guards before starting crane.
7. Use a clean funnel equipped with a strainer for pouring lubricants.
8. Clean the area around check and fill plugs before removing them to prevent entry of foreign particles.

Note: See specific instructions in this Section of this Operator's Manual for lubrication check and change procedures on all gear compartments.

Keep grease, oil, containers, and guns clean. Wipe all fittings before lubrication. Block the tracks and shutdown the engine before working on the crane. Replace all guards or panels before operating the crane.

Operator's Manual

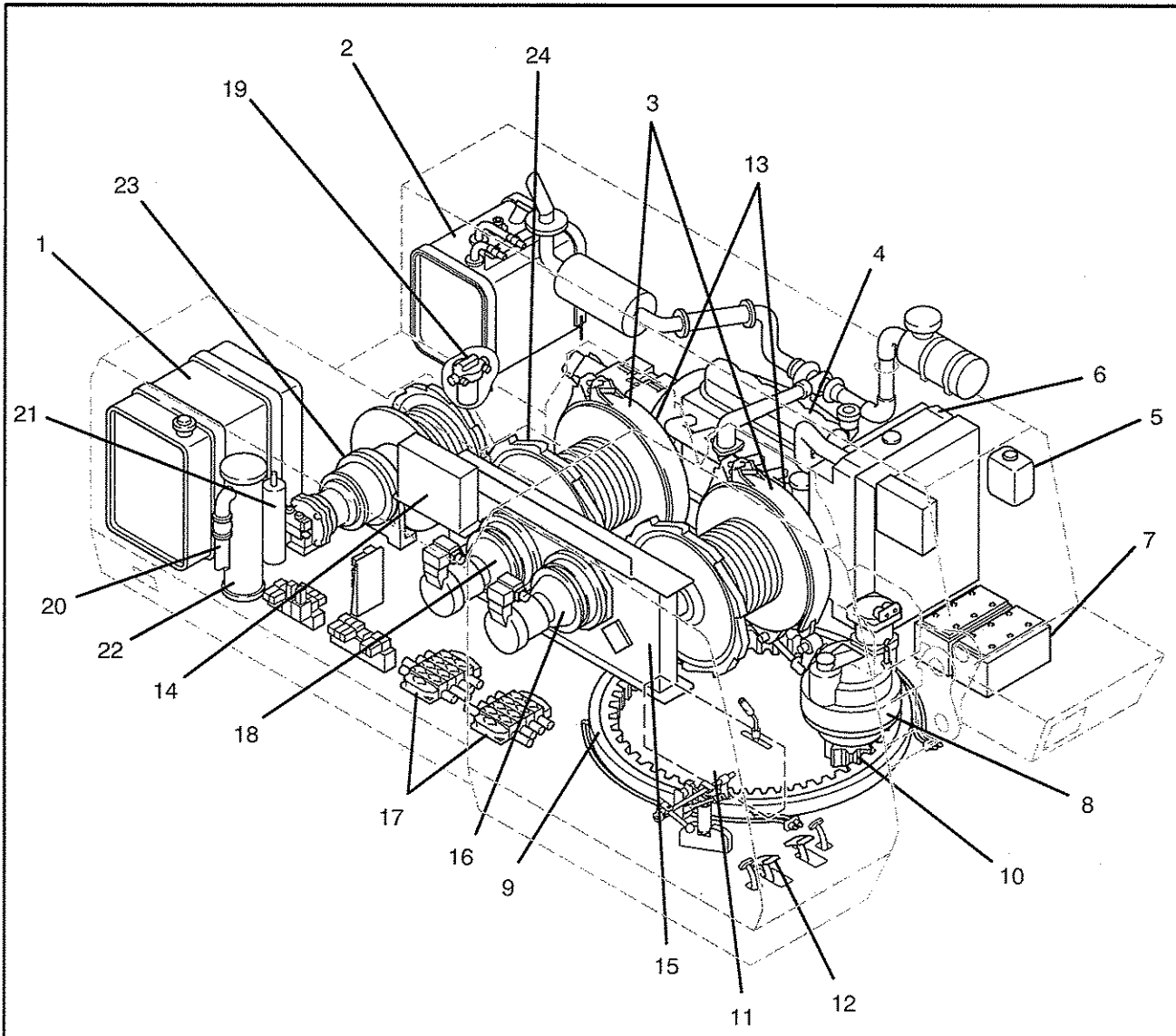

Figure 2-1
Upper Lubrication And Maintenance

Upper Lubrication

No.	Point	Capacity gal (L)	Spec.	No. of Points	Intervals (hrs)				
					10	50	250	500	1000
1	Fuel tank	77 (290)	Diesel fuel **	1	When required. Drain water as required.				
	Fuel filters **	—	—	2	Drain water			●	
2	Hydraulic reservoir	42 (160)	Hydraulic oil ***	1	⊙				Change oil every 1500 hours
3	Front and Rear hoist drum brakes	—	—	2		Check and adjust			
4	Engine oil	**	Engine oil **	1	⊙	△	●		

Operator's Manual

No.	Point	Capacity gal (L)	Spec.	No. of Points	Intervals (hrs)				
					10	50	250	500	1000
5	Radiator reservoir tank	H=0.4 (1.5) L=.11 (0.43)	Soft water with long life coolant **	1	○				●
6	Radiator	6.2 (23.5)	Soft water with long life coolant **	1	○				
7	Battery	As required	Distilled water	2		○			
8	Swing reduction unit	2.4 (9)	Gear oil ***	1			○		●
9	Turntable bearing	*	E.P. grease ***	4		○	Check bolt torque		
10	Swing/Turntable gear teeth	Grease	E.P. grease	All points			○		●
11	Control valve rods	—	—	All points	Check for bends, loose nuts				
12	Drum brake pedals (Front and Rear)	—	—	2		Check pedal stroke			
13	Clutch and related parts	—	—	All points		Check and adjust			
14	Fuse	—	—	All points			Check for deterioration		
15	Front/Rear hoist gear case	3.1 (11.7)	Gear oil ***	2			○		●
16	Main hoist hydraulic motor reduction gear	1.8 (6.8)	Gear oil ***	1			○		●
17	Control valves	—	—	All points		Check for oil leakage			
18	Main hoist hydraulic motor reduction gear	1.8 (6.8)	Gear oil ***	1			○		●
19	Line filter	—	—	1		△		●	
20	Couplings and lines	—	—	All points	Visually check				
21	Accumulator	—	Nitrogen gas	1			Check gas pressure		
22	Return filter	3.7 (14)	—	1		△		●	
23	Boom hoist hydraulic motor reduction gear	0.6 (2.3)	Gear oil ***	2			○		●
24	Drum lock (front, rear, boom hoist)	—	—	4	Visually check				
Not Shown	Front mounted third drum (Braden), if equipped	0.88 (3.3)	Gear oil ***	1			○		●
Not Shown	Fourth drum (Braden), if equipped	0.88 (3.3)	Gear oil ***	1			○		●
Not Shown	Fourth drum gear case (HSC), if equipped	6.7 (25.4)	Gear oil ***	1			○		●
Not Shown	Fourth drum hydraulic motor reduction gear (HSC), if equipped	1.3 (4.9)	Gear oil ***	1			○		●

○: Check and add as required.
 ○: Lubricate with grease.

△: Change initially.
 ●: Change oil, grease, or coolant or replace element.

Notes:

Grease capacity is for one unit.

* Apply grease in the amount to cause old grease to be expelled. Do not apply too much grease.

** Refer to the engine manufacturer's manual for specifications.

*** Refer to the Operator's Manual for specifications.

Operator's Manual

Lower Lubrication

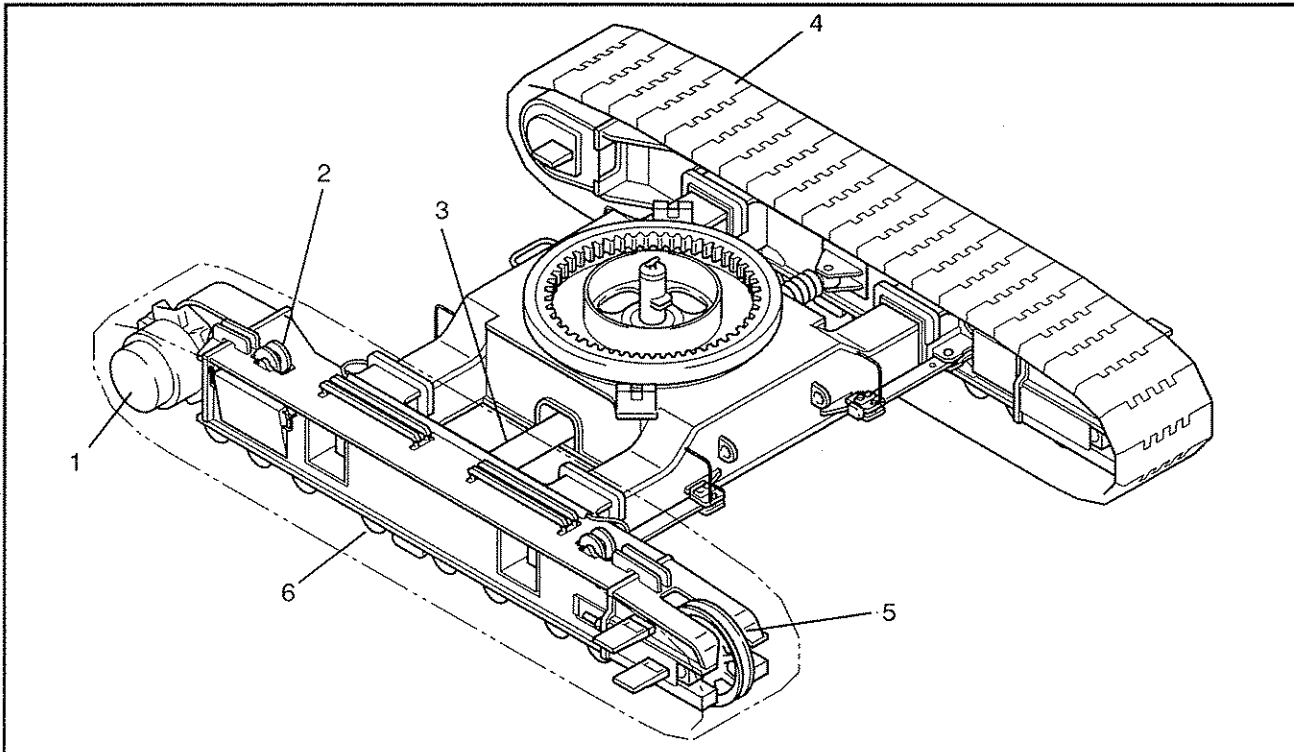

Figure 2-2
Lower Lubrication And Maintenance

No.	Point	Capacity gal (L)	Spec.	No. of Points	Intervals (hrs)				
					10	50	250	500	1000
1	Travel reduction gear	1.8 (6.8)	Gear oil *	2			⊙		●
2	Upper roller	0.1 (0.2)	Engine oil *	4	Check for oil leakage		⊙		●
3	Side frame extend/retract cylinder	—	—	2			○		
4	Track shoe	—	—	All points		Check tension		Check every 500 hours.	
5	Front idler	0.2 (0.6)	Engine oil *	2	Check for oil leakage		⊙		●
6	Lower roller	0.8 (3.2)	Engine oil *	16	Check for oil leakage		⊙		●

⊙: Check and add as required.

○: Lubricate with grease.

△: Change initially.

●: Change oil, grease, or coolant or replace element.

Notes:

Grease capacity is for one unit.

* Refer to the Operator's Manual for specifications.

Attachment Lubrication

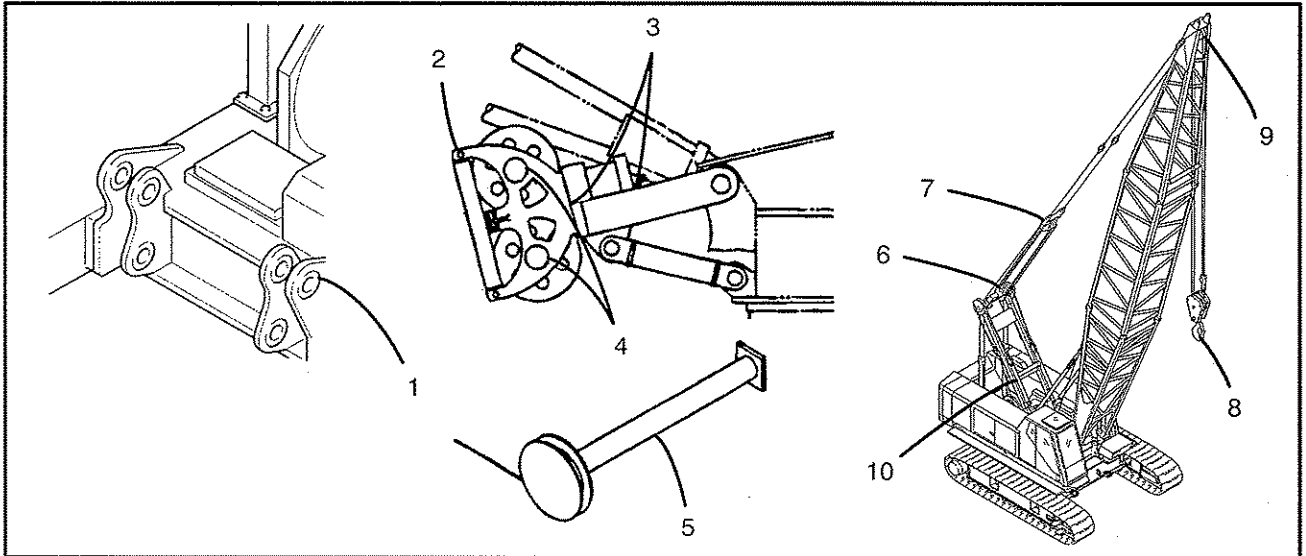

Figure 2-3
Attachment Lubrication And Maintenance

No.	Point	Capacity gal (L)	Spec.	No. of Points	Intervals (hrs)				
					10	50	250	500	1000
1	Boom foot pin	*	E.P. grease **	2	○				
2	Fairleader roller	*	E.P. grease **	4		○			
3	Fairleader base	*	E.P. grease **	2		○			
4	Fairleader sheave	*	E.P. grease **	2		○	Check wear of groove		
5	Tagline	3.4 (13)	Gear oil **	1	Check oil leakage		⊙		
6	Bail Sheave	*	E.P. grease **	All points		○			
7	Bridle Sheave	*	E.P. grease **	All points		○			
8	Hook block/Hook ball	*	E.P. grease **	All points		○			
9	Boom Head Sheave	*	E.P. grease **	All points		○			
10	Counterweight Cylinder	*	E.P. grease **	2			○		

⊙: Check and add as required.

○: Lubricate with grease.

△: Change initially.

●: Change oil, grease, or coolant or replace element.

Notes:

Grease capacity is for one unit.

* Apply grease in the amount to cause old grease to be expelled. Do not apply too much grease.

** Some cranes are equipped with sealed bearings. Grease only if sheaves are equipped with grease fittings.

Operator's Manual

Lubricant Specifications						
Supply point	Oil type	Use according to ambient temperature				
		-10 14	0 32	10 50	20 68	30°C 86°F
Engine oil pan	Engine oil API-CD class	SAE 30				
		SAE 10W 30				
Swing reduction gear Travel reduction gear Tagline	Gear oil API-GL-4 class	SAE 90				
Hydraulic oil tank	Hydraulic oil **	ISO-VG 22				
		ISO-VG 46				
Fuel tank	Diesel Fuel*	No. 2D				
		No. 1D				
Cooling system	Water with long life coolant*	Add antifreeze solution				
Turntable bearing	E.P. Grease Extreme pressure type	EP 1				
		EP 2				

Notes:

When operating in an ambient temperature above or below those shown here contact your Link-Belt Distributor.

* Refer to the engine manufacturer's manual for specifications.

** Refer to the Operator's Manual for specifications.

1 Diesel Fuel

Use per the chart, according to the ambient temperature.

2 Antifreeze

Below temperature of 32°F (0°C), add antifreeze.

Operator's Manual

Hi Performance Hydraulic Oil Chart

Important

Use only pre-filtered hydraulic oil. Warranty is void if incorrect oil is used. Incorrect oil may result in damage to hydraulic components. Hi Performance Hydraulic Oil is available through your Link-Belt Distributor in the following viscosities and quantities.

Oil Viscosity	Temperature Range		Container Capacity		Link-Belt Part Number
	Ambient Temperature Use	Maximum Hydraulic System Temperature	Gallons	Liters	
Grade 22	-45°F to 80°F	150°F	5	18.9	830666001 830666002
	-43°C to 27°C	65°C	55	208.0	
Grade 46	10°F to 90°F	195°F	5	18.9	830663001 830663002
	-12°C to 32°C	91°C	55	208.0	

Please Don't Do It !

Properly dispose of used lubricants and filters. Every drop of misplaced oil damages the environment. Each year literally thousands of gallons of used oil is dumped into our fields and streams or buried in community landfills. These methods of disposal permanently damage the world around us. You can see that the oil you use is properly disposed of by sending it to a recycling center. Most local automobile service stations are happy to receive used oil and will see to it that the oil is recycled.



A1259A

Operator's Manual

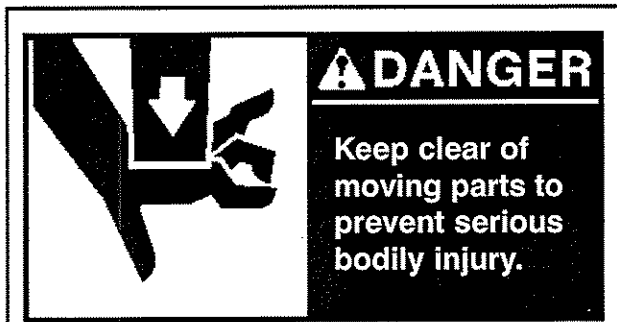

Figure 1-2
Keep hands and tools clear of moving parts.

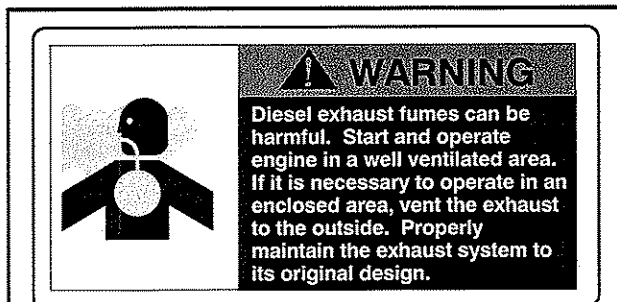

Figure 1-3
Diesel exhaust fumes can be harmful.

Operating Safety

Remember SAFETY every day. Someone's LIFE may depend on it, MAYBE YOUR OWN.

Safe operations of a crane requires a well trained, qualified operator. Crane operation is more involved than it may appear, and operation by a careless or unqualified person can result in a serious accident.

When a crane is maintained and used properly it can be a safe, highly productive piece of equipment, but if not used properly, it can be dangerous.

Think Safety – You, the operator, are in charge of an important piece of equipment. It is very important that you know what it can do. It is also important that you know what it should not do. No set of instructions can anticipate all of the situations you will encounter. The rules given here cover the general usage, and some of the more common specific cases. If conditions arise not covered by these rules, contact your Link-Belt Distributor. A phone call could save someone's life.



Figure 1-4
Do not smoke when fueling, or fuel up near an open flame.

General Safety Rules

The following is a list of safety rules which should be followed during all crane operations.

Operator Awareness

1. Read, understand, and follow all instructions given in this Operator's Manual. This Operator's Manual contains critical information for operation and maintenance of this crane.
2. An operator must not eat, read, or otherwise divert his attention while operating a crane. Remember—operating is a full-time job.
3. Don't smoke when fueling, or fuel up near an open flame. Keep the nozzle in contact with the filler neck to prevent static electric sparks. Shutdown the engine when fueling.
4. Start and operate the engine in a well ventilated area. Diesel exhaust fumes can be harmful. If it is necessary to operate in an enclosed area, vent the exhaust to the outside. Properly maintain the exhaust system to its original design.
5. Keep your shoes clean. Before entering the operator's cab, wipe clean any mud, gravel, snow, ice, moisture, or grease from your shoes. Slippery shoes could cause momentary loss of control of crucial foot operated controls.
6. Keep all walking surfaces (steps, ladders, platforms, etc.) on the crane clean. They are on the crane to assist operators and service personnel with safe access/egress to/from the crane and to/from adjustment and inspection areas.
7. Keep fingers, feet, and clothing away from sheaves, drums, and wire ropes unless the crane is shutdown and everyone knows what you are doing. Do not place a hand on wire ropes when climbing on the crane. A sudden movement could pull them into the drums or sheaves. Do not wear loose clothing which may be caught in machinery.

Operator's Manual

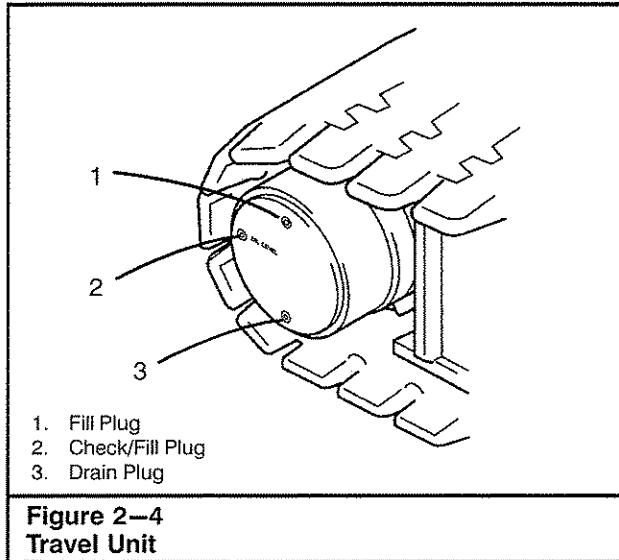

Travel Unit Lubrication

Check oil level in travel unit after every 250 hours of operation. Thereafter, change the oil with each 1,000 hours of operation or seasonally, whichever occurs first.

Travel Unit Oil Level Check

1. Travel the crane until the drain plug is positioned on the bottom vertical center line of the travel gear. Crane must be on a firm level surface. Refer to Figure 2-4.
2. Position upper directly over the rear of the lower, engage the travel swing lock and shutdown the engine.
3. Thoroughly clean the exterior surface of the gear case around the check and fill plugs to prevent contamination from entering the unit.
4. Remove the check plug. Oil should be level with the bottom of hole. Refer to Figure 2-5.
5. If necessary, add oil until it begins to flow from the fill plug hole. Refer to the Lubrication Chart for the correct grade of oil.
6. Clean and install the check/fill plug.

Travel Unit Oil Change

1. Travel the crane for several minutes, without a load, to agitate and warm the oil within the gear case. Travel the crane until the drain plug is positioned on the bottom vertical center line of the travel gear. Crane must be on a firm level surface. Refer to Figure 2-4.
2. Park the crane on a firm level surface. Position the upper directly over the rear of the lower, engage the travel swing lock, and shutdown the engine.

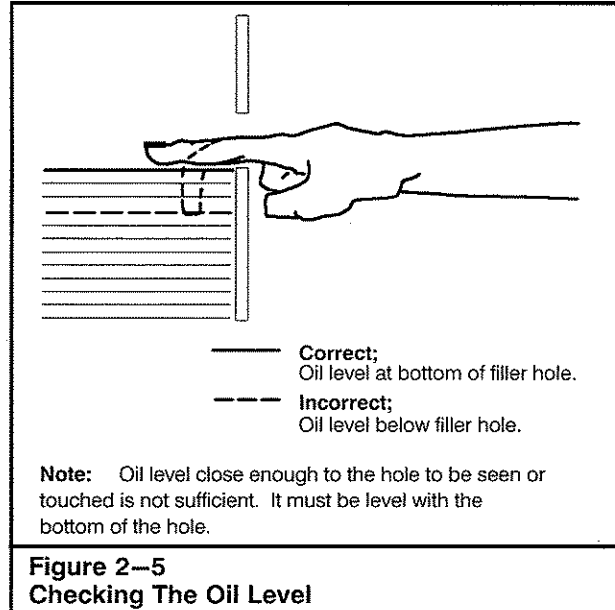

3. Thoroughly clean the exterior surface of the gear case around the check, fill, and drain plugs to prevent contamination from entering the unit. Refer to Figure 2-4.
4. Remove the check, fill, and drain plugs and allow the oil to drain into a suitable container.
5. After the oil has thoroughly drained, clean and install the drain plug.
6. Fill the unit with oil until it begins to flow from the check hole. Refer to Figure 2-5. Refer to the Lubrication Chart for the correct grade and quantity of oil.
7. Clean and install the check and fill plugs. Properly dispose of the used oil.

Engine Air System Inspection

In addition to servicing the air cleaner, it is also recommended that the engine air system be inspected every 250 hours or 6 months. Inspect the air system pipes, hoses, and turbocharger systems, as equipped. (Always inspect all the pipes and hoses associated with the turbocharger, air cleaner, and air intake.) Check for any cracks, corrosion, loose clamps, wear points, leaks, or punctures which can allow contaminants to enter the system and damage air system components and/or the engine. All hoses should be kept free of oil contaminants, both internally and externally. Disassemble and clean as required. Tighten or replace parts as necessary to ensure that the air system does not leak.

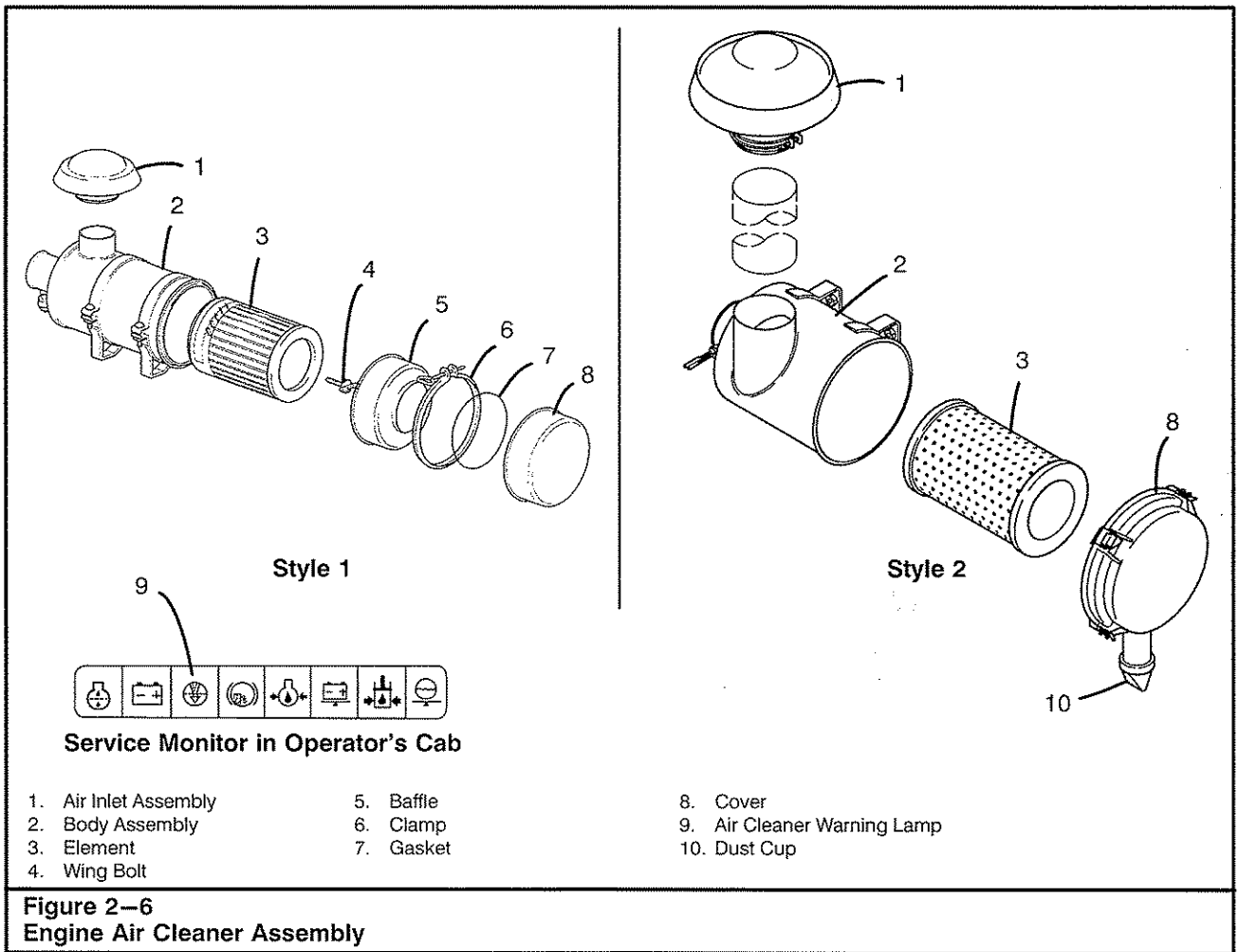

Engine Air Cleaner

Variations in job site conditions prevent establishing a set interval for air cleaner servicing. For this reason a warning lamp on the service monitor is used to assist in determining the condition of the air cleaner elements. Refer to Figure 2-6. Anytime the filter lamp illuminates, service the air cleaner immediately. Clean or replace an air cleaner element as often as required. Replace an air cleaner element after six cleanings or annually, whichever occurs first. Service the engine air cleaner as follows:

Changing The Engine Air Cleaner Element

1. Properly park the crane on a firm level surface. Position the upper directly over the end of the lower, engage the travel swing lock, and shutdown the engine.

2. Remove the cover from the end of the body assembly. Refer to Figure 2-6. Remove the dust cup, if equipped, and clean with a damp cloth. Install dust cup back onto cover.
3. Remove the element within the body.
4. Wipe the inside of the filter body clean, using a damp cloth.
5. Clean or replace the element, as required. Refer to "Cleaning The Air Cleaner Element" in this Section of this Operator's Manual.
6. Slide the element inside the filter body and install the gasket if required.
7. If required, remove the baffle assembly from the cover and wipe both clean with a damp cloth.
8. If required, install the baffle assembly in the cover and install the cover on the body.
9. Position the cover to body and secure with the clamp(s).

Operator's Manual

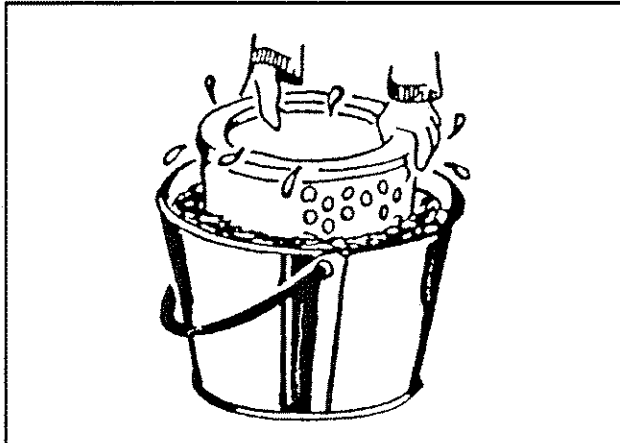

Figure 2-7
Cleaning the air cleaner element by soaking.



Figure 2-9
Inspecting the air cleaner element.

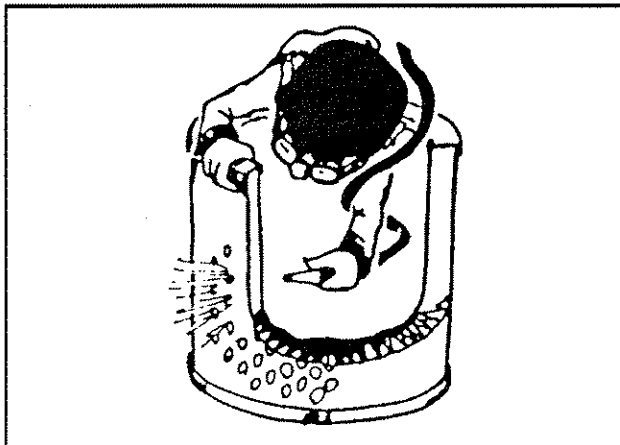

Figure 2-8
Cleaning the air cleaner element with compressed air.

Cleaning The Air Cleaner Element

Air cleaner elements can be cleaned by washing or using compressed air. Compressed air is recommended when the element is to be reused immediately. A washed element must dry before reuse, however the washing method does a better job and must be used when exhaust soot has lodged in the fine pores of the filter media. Use one of the following procedures to clean the air cleaner element:

Washing

Soak the air cleaner element for 15 minutes or more, in a solution of water and Donaldson D-1400 detergent, or equivalent. Refer to Figure 2-7. Thoroughly rinse the element by spraying it with a hose in the direction opposite the air flow. Use water pressure of less than 40 psi (19.4kgf/cm^2) to prevent damage to the filter paper within the element. Rinse until the water is clear; air dry. Do not attempt to dry the element using compressed air or light bulbs. This may ruin the element. Thoroughly inspect the element after cleaning.

Compressed Air

Hold an air hose nozzle at least 1 in (25mm) away from the air cleaner element. Spray air through the element in the direction opposite to normal air flow. Move the nozzle up and down while rotating the element. Use air pressure of less than 100 psi (7kgf/cm^2) to prevent damage to the filter paper within the element. Thoroughly inspect the element after cleaning. Refer to Figure 2-8.

Inspecting The Air Cleaner Element

Place a bright light inside the air cleaner element and rotate the element. Inspect the element from the outside looking for ruptures, tears, and holes. If any damage is discovered, replace the element. Refer to Figure 2-9.

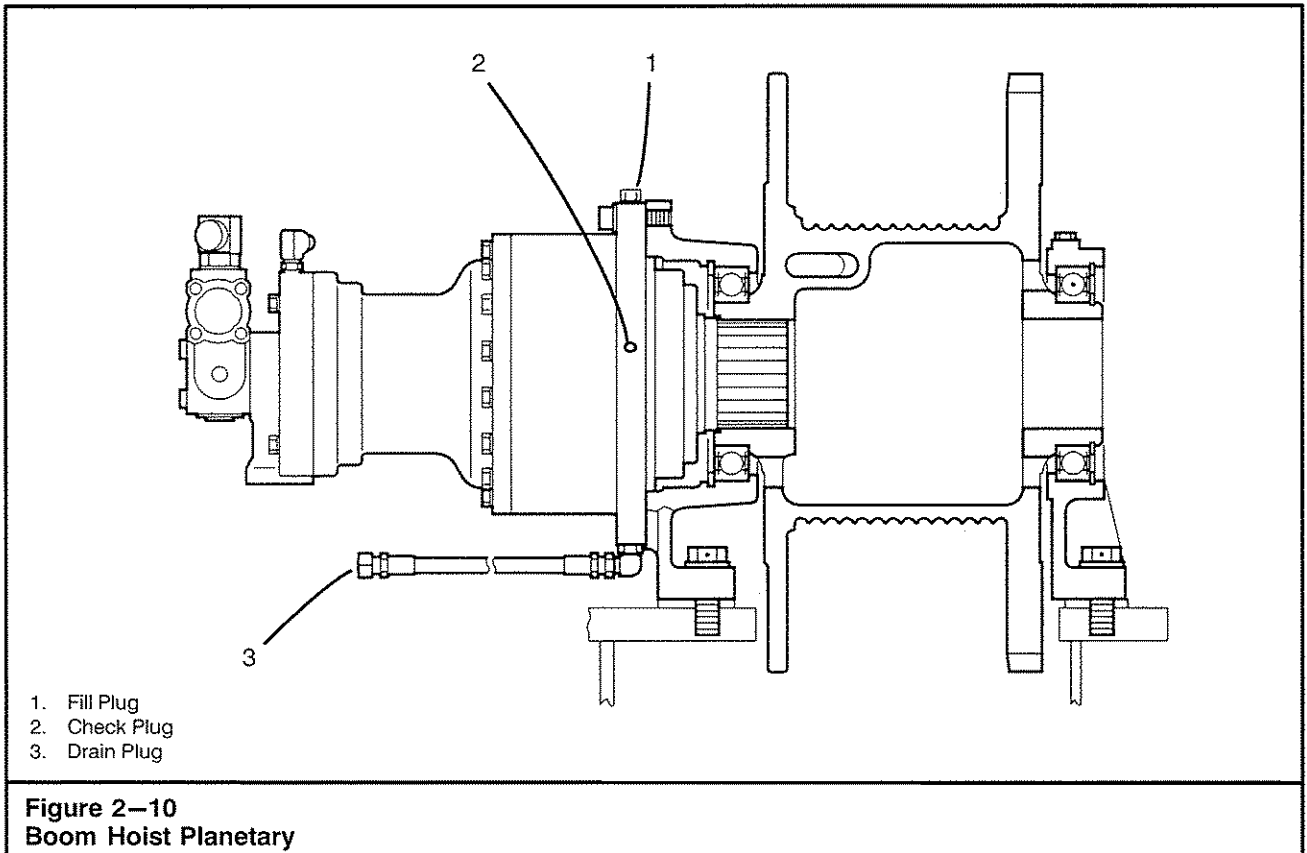

Boom Hoist Lubrication

Check the oil level in the gear case and planetary after every 250 hours of operation. Thereafter, change the oil with each 1,000 hours of operation or seasonally, whichever occurs first.

Boom Hoist Planetary Oil Level Check

1. Park the crane on a firm level surface.
2. Position the upper directly over the front or rear of the lower, engage the travel swing lock, and shut-down the engine.
3. Thoroughly clean the exterior surface of the planetary around the check and fill plugs to prevent contamination from entering the unit. Refer to Figure 2-10.
4. Remove the check plug. Oil should be level with the bottom of the hole. Refer to Figure 2-12.
5. If necessary, remove the fill plug and add oil until it begins to flow from the check plug hole. Refer to Figure 2-12. Refer to the Lubrication Chart for the correct grade of oil.
6. Clean and install the check and fill plugs.

Boom Hoist Planetary Oil Change

1. Park the crane on a firm level surface.
2. Cycle the boom hoist winch for several minutes, without a load, to agitate and warm the oil within the planetary.
3. Position the upper directly over the front or rear of the lower, engage the travel swing lock, and shut-down the engine.
4. Thoroughly clean the exterior surface of the planetary around the check, fill, and drain plugs to prevent contamination from entering the unit. Refer to Figure 2-10.
5. Remove the check, fill, and drain plugs and allow the oil to drain into a suitable container.
6. After the oil has thoroughly drained, clean and install the drain plug.
7. Fill the unit with oil through the fill plug hole, until oil is level with the bottom of the check plug hole. Refer to Figure 2-12. Refer to the Lubrication Chart for the correct grade and quantity of oil.
8. Clean and install the check and fill plugs. Properly dispose of the used oil.

Operator's Manual

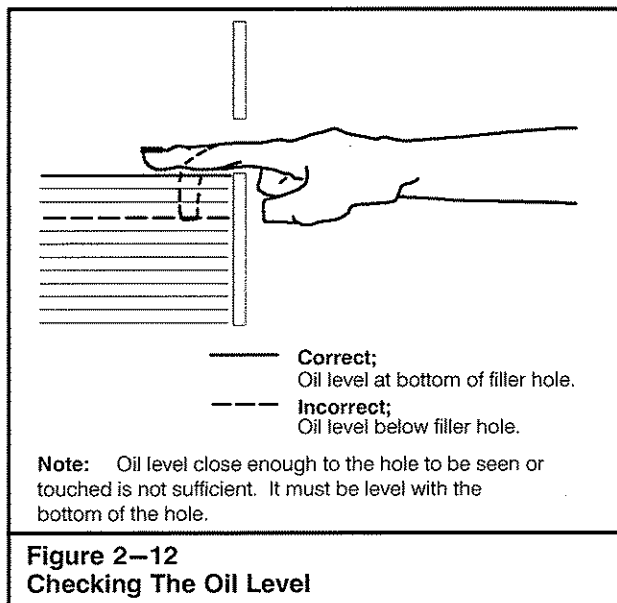
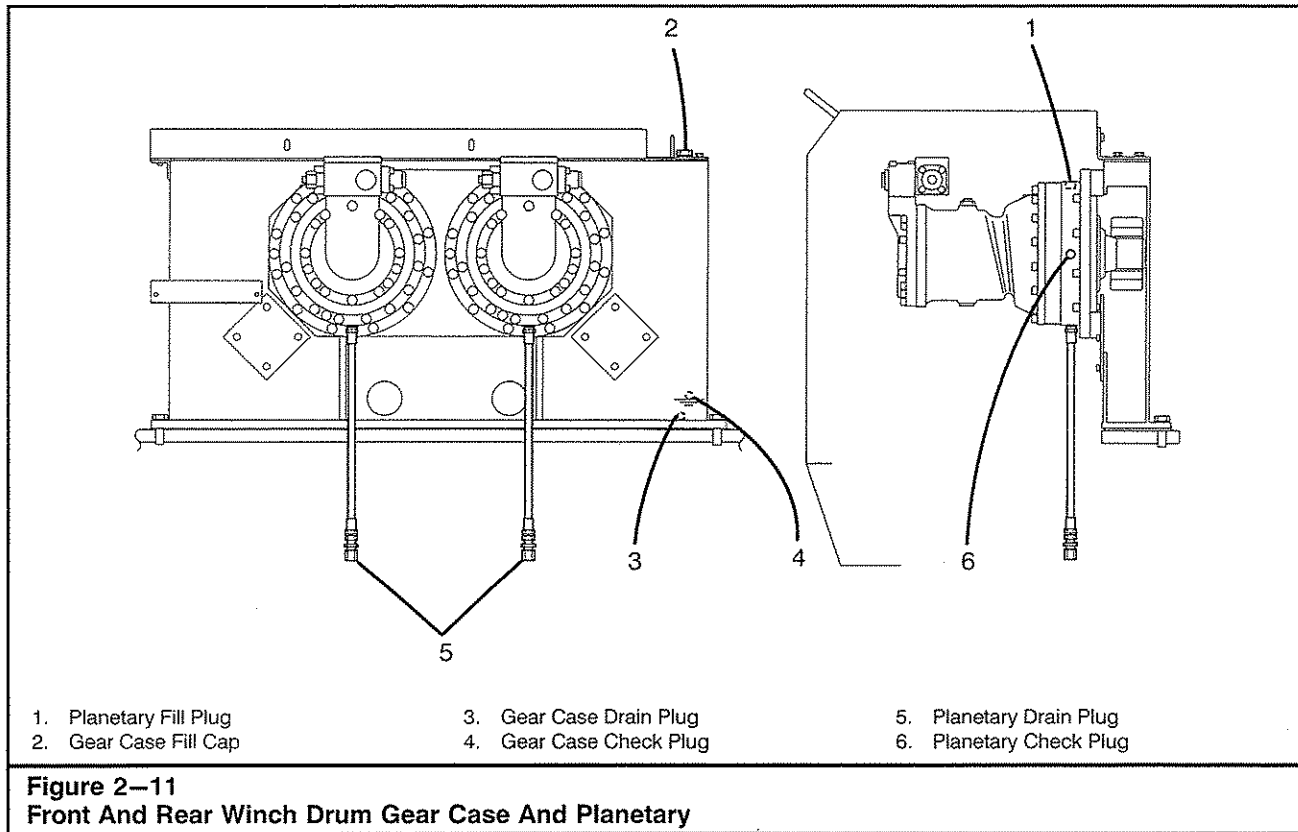

Front And Rear Winch Drum Lubrication

Check the oil level in the gear case and planetary after every 250 hours of operation. Thereafter, change the oil with each 1,000 hours of operation or seasonally, whichever occurs first.

Winch Drum Gear Case Oil Level Check

1. Park the crane on a firm level surface.
2. Position the upper directly over the front or rear of the lower, engage the travel swing lock, and shut-down the engine.
3. Thoroughly clean the exterior surface of the gear case and around the check plug and fill cap to prevent contamination from entering the unit. Refer to Figure 2-11.

Operator's Manual

4. Remove the check plug. Oil should be level with the bottom of hole. Refer to Figure 2–12.
5. If necessary, remove the fill cap and add oil until it begins to flow from the check plug hole. Refer to the Lubrication Chart for the correct grade of oil.
6. Clean and install the check plug and fill cap.

Winch Drum Gear Case Oil Change

1. Park the crane on a firm level surface.
2. Cycle the winch for several minutes, without a load, to agitate and warm the oil within the gear case.
3. Position the upper directly over the front or rear of the lower, engage the travel swing lock, and shut-down the engine.
4. Thoroughly clean the exterior surface of the gear case around the check and drain plugs, and the fill cap to prevent contamination from entering the unit. Refer to Figure 2–11.
5. Remove the check and drain plugs and the fill cap. Allow the oil to drain into a suitable container.
6. After the oil has thoroughly drained, clean and install the drain plug.
7. Fill the unit with oil, through the fill hole, until it begins to flow from the check hole. Refer to Figure 2–12. Refer to the Lubrication Chart for the correct grade and quantity of oil.
8. Clean and install the check and fill plugs. Properly dispose of the used oil.

Winch Drum Planetary Oil Level Check

1. Park the crane on a firm level surface.
2. Position the upper directly over the front or rear of the lower, engage the travel swing lock, and shut-down the engine.

3. Thoroughly clean the exterior surface of the planetary around the check and fill plugs to prevent contamination from entering the unit. Refer to Figure 2–11.
4. Remove the check plug. Oil should be level with the bottom of hole. Refer to Figure 2–12.
5. If necessary, remove the fill cap and add oil until it begins to flow from the check plug hole. Refer to the Lubrication Chart for the correct grade of oil.
6. Clean and install the check and fill plugs.

Winch Drum Planetary Oil Change

1. Park the crane on a firm level surface.
2. Cycle the winch for several minutes, without a load to agitate and warm the oil within the planetary.
3. Position the upper directly over the front or rear of the lower, engage the travel swing lock and shut-down the engine.
4. Thoroughly clean the exterior surface of the planetary around the check, fill, and drain plugs to prevent contamination from entering the unit. Refer to Figure 2–11.
5. Remove the check, fill, and drain plugs and allow the oil to drain into a suitable container.
6. After the oil has thoroughly drained, clean and install the drain plug.
7. Fill the unit with oil through the fill hole, until it begins to flow from the check plug hole. Refer to the Lubrication Chart for the correct grade and quantity of oil.
8. Clean and install the check and fill plugs. Properly dispose of the used oil.

Operator's Manual

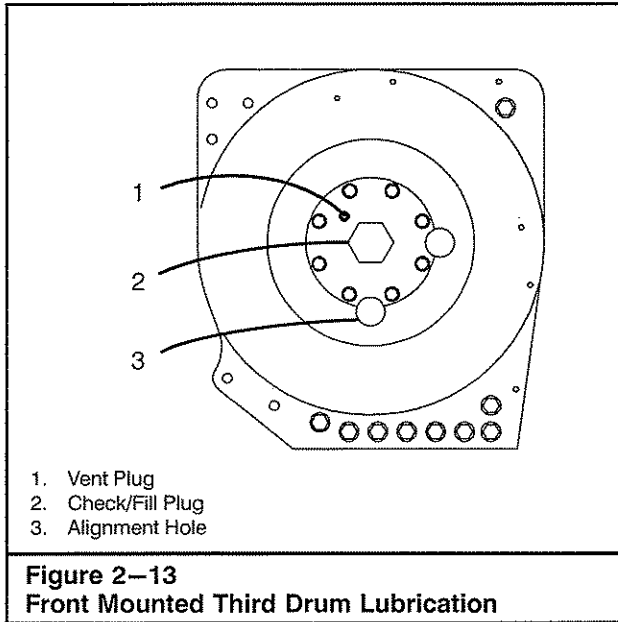

Front Mounted Third Drum Winch Lubrication

Check the oil level in the gear case after every 250 hours of operation. The oil, in a new or rebuilt gear case should be changed after the initial 250 hours of operation. Thereafter, change the oil with each 1,000 hours of operation or seasonally, whichever occurs first.

Third Drum Oil Level Check

1. Park the crane on a firm level surface.
2. Position the upper directly over the rear of the lower and engage the travel swing lock.
3. Remove the check/fill plug. Oil should be level with the bottom of hole. Refer to Figure 2-12.
4. If necessary, add oil until it is level with the bottom of the check/fill plug hole. Refer to the Lubrication Chart for the correct grade of oil.
5. Clean and install the check/fill plug.

Third Drum Oil Change

1. Park the crane on a firm level surface.
2. Cycle the third drum winch for several minutes, without a load, to agitate and warm the oil within the gear case.
3. Position the upper directly over the rear of the lower and engage the travel swing lock.
4. Thoroughly clean the exterior surface of the planetary around the check/fill and drain plugs to prevent contamination from entering the unit. Refer to Figure 2-13.
5. Remove the check/fill plug.
6. Install a short piece of pipe, one inch (25.4mm) in diameter, in the alignment hole.
7. Remove the drain plug through the pipe and allow the oil to drain into a suitable container.
8. After the oil has thoroughly drained, remove the vent plug.
9. Clean and install the drain and vent plugs.
10. Fill the unit with oil through the check/fill hole, until oil is level with the bottom of the hole. Refer to Figure 2-12. Refer to the Lubrication Chart for the correct grade and quantity of oil.
11. Clean and install the check/fill plug. Properly dispose of the used oil.

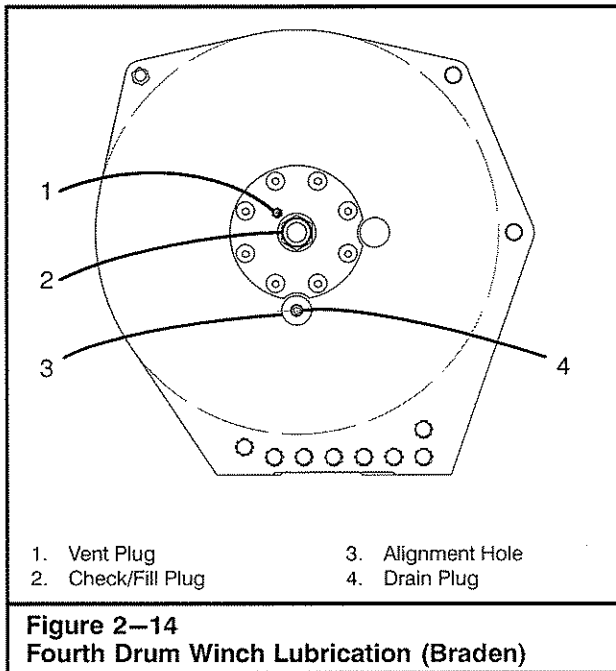

Fourth Drum Winch Lubrication (Braden)

Check the oil level in the gear case after every 150 hours of operation. The oil, in a new or rebuilt gear case should be changed after the initial 250 hours of operation. Thereafter, change the oil with each 1,000 hours of operation or 6 months, whichever occurs first.

Fourth Drum Oil Level Check

1. Park the crane on a firm level surface.
2. Position the upper directly over the rear of the lower and engage the travel swing lock.
3. Remove the check/fill plug. Oil should be level with the bottom of hole.
4. If necessary, add oil until it is level with the bottom of the check/fill plug hole. Refer to the Lubrication Chart for the correct grade of oil.
5. Clean and install the check/fill plug.

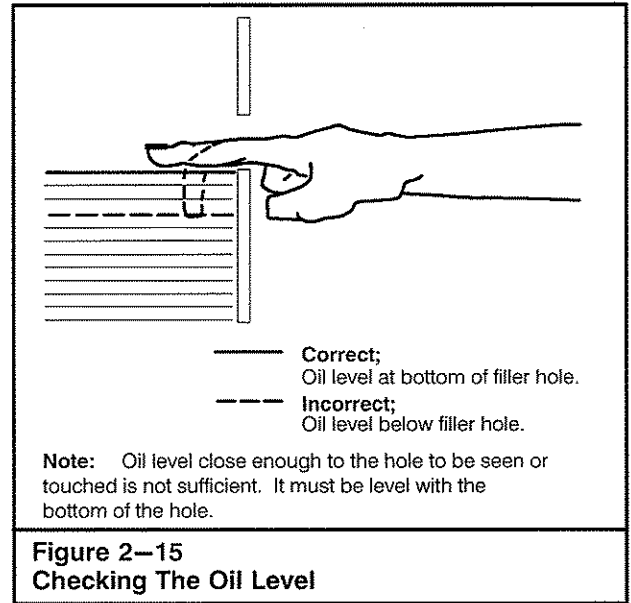

Fourth Drum Oil Change

1. Park the crane on a firm level surface.
2. Cycle the third drum winch for several minutes, without a load, to agitate and warm the oil within the gear case.
3. Position the upper directly over the rear of the lower and engage the travel swing lock.
4. Thoroughly clean the exterior surface of the planetary around the check/fill and drain plugs to prevent contamination from entering the unit. Refer to Figure 2-13.
5. Remove the check/fill and vent plugs.
6. Install a short piece of pipe, one inch (25.4mm) in diameter, in the alignment hole.
7. Remove the drain plug through the pipe and allow the oil to drain into a suitable container.
8. After the oil has thoroughly drained, clean and install the drain and vent plugs.
9. Fill the unit with oil through the check/fill hole, until oil is level with the bottom of the hole. Refer to the Lubrication Chart for the correct grade and quantity of oil.
10. Clean and install the check/fill plug. Properly dispose of the used oil.

Operator's Manual

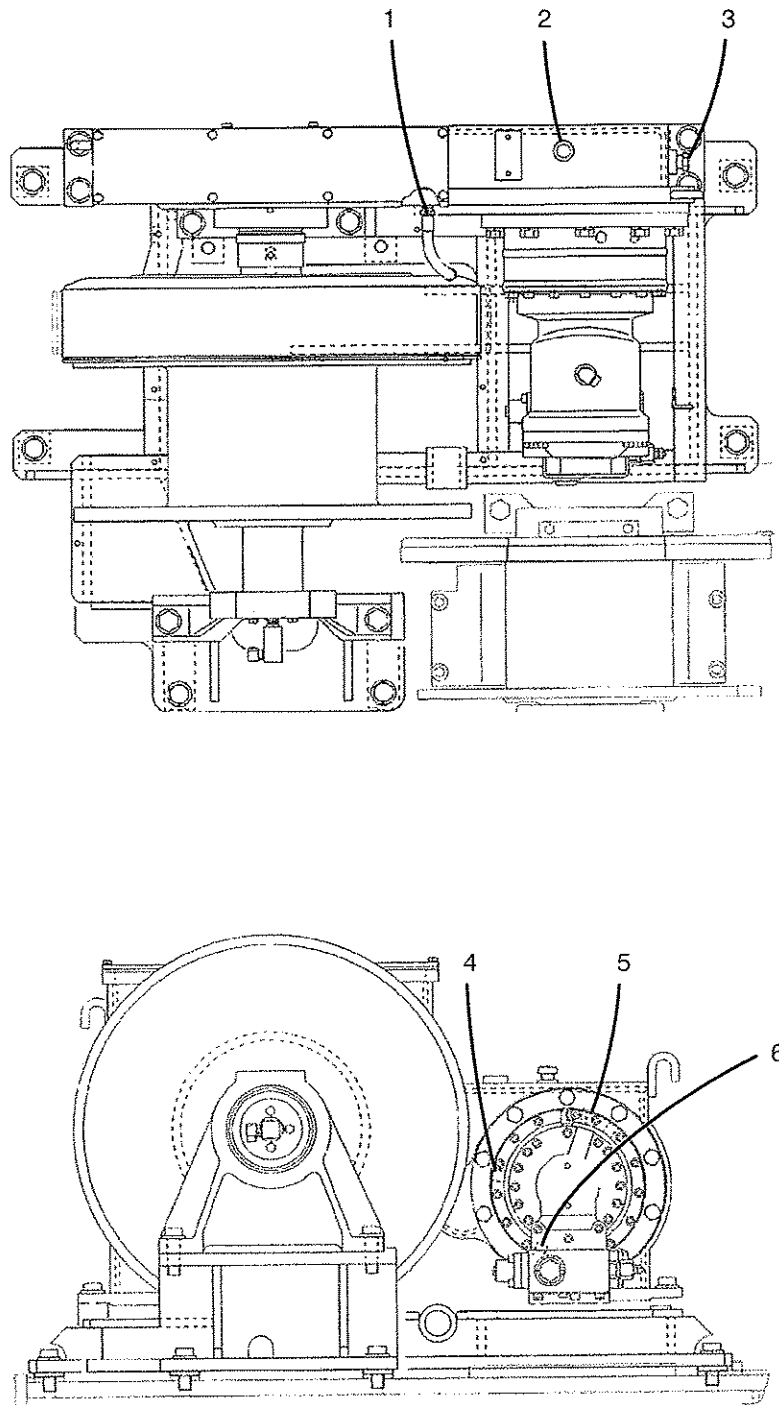

- 1. Gear Case Drain Hose (Plug)
- 2. Gear Case Fill Plug

- 3. Gear Case Check Plug
- 4. Reduction Unit Check Plug

- 5. Reduction Unit Fill Plug
- 6. Reduction Unit Drain Plug

Figure 2-16
Fourth Drum Gear Case And Reduction Unit (HSC)

Fourth Drum Winch Lubrication (HSC)

Check the oil level in the gear case and reduction unit after every 250 hours of operation. Thereafter, change the oil with each 1,000 hours of operation or seasonally, whichever occurs first.

Fourth Drum Gear Case Oil Level Check

1. Park the crane on a firm level surface.
2. Position the upper directly over the front or rear of the lower, engage the travel swing lock, and shut-down the engine.
3. Thoroughly clean the exterior surface of the gear case and around the check and fill plugs to prevent contamination from entering the unit. Refer to Figure 2-16.
4. Remove the check plug. Oil should be level with the bottom of hole. Refer to Figure 2-17.
5. If necessary, remove the fill plug and add oil until it begins to flow from the check plug hole. Refer to the Lubrication Chart for the correct grade of oil.
6. Clean and install the check and fill plugs.

Fourth Drum Gear Case Oil Change

1. Park the crane on a firm level surface.
2. Cycle the winch for several minutes, without a load, to agitate and warm the oil within the gear case.
3. Position the upper directly over the front or rear of the lower, engage the travel swing lock, and shut-down the engine.
4. Thoroughly clean the exterior surface of the gear case around the check, drain, and the fill plugs to prevent contamination from entering the unit. Refer to Figure 2-16.
5. Remove the check, drain, and fill plugs. Allow the oil to drain into a suitable container.
6. After the oil has thoroughly drained, clean and install the drain plug.
7. Fill the unit with oil, through the fill hole, until it begins to flow from the check hole. Refer to Figure 2-17. Refer to the Lubrication Chart for the correct grade and quantity of oil.
8. Clean and install the check and fill plugs. Properly dispose of the used oil.

Fourth Drum Reduction Unit Oil Level Check

1. Park the crane on a firm level surface.
2. Position the upper directly over the front or rear of the lower, engage the travel swing lock, and shut-down the engine.

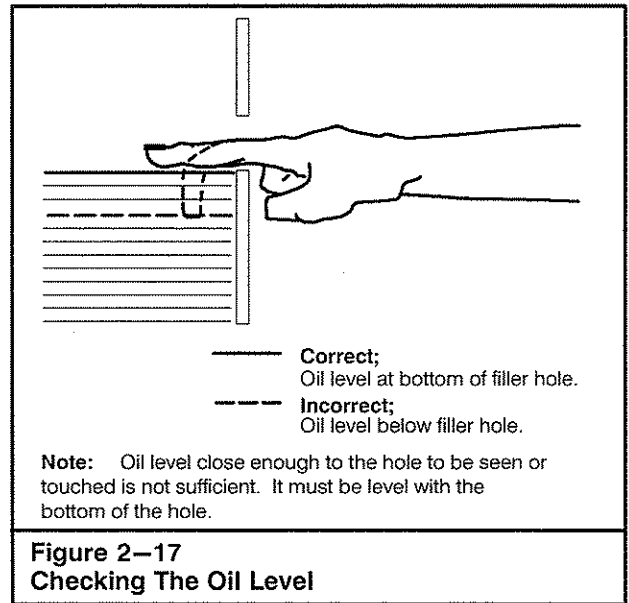

3. Thoroughly clean the exterior surface of the reduction unit around the check and fill plugs to prevent contamination from entering the unit. Refer to Figure 2-16.
4. Remove the check plug. Oil should be level with the bottom of hole. Refer to Figure 2-17.
5. If necessary, remove the fill cap and add oil until it begins to flow from the check plug hole. Refer to the Lubrication Chart for the correct grade of oil.
6. Clean and install the check and fill plugs.

Fourth Drum Reduction Unit Oil Change

1. Park the crane on a firm level surface.
2. Cycle the winch for several minutes, without a load to agitate and warm the oil within the planetary.
3. Position the upper directly over the front or rear of the lower, engage the travel swing lock and shut-down the engine.
4. Thoroughly clean the exterior surface of the reduction unit around the check, fill, and drain plugs to prevent contamination from entering the unit. Refer to Figure 2-16.
5. Remove the check, fill, and drain plugs and allow the oil to drain into a suitable container.
6. After the oil has thoroughly drained, clean and install the drain plug.
7. Fill the unit with oil through the fill hole, until it begins to flow from the check plug hole. Refer to the Lubrication Chart for the correct grade and quantity of oil.
8. Clean and install the check and fill plugs. Properly dispose of the used oil.

Operator's Manual

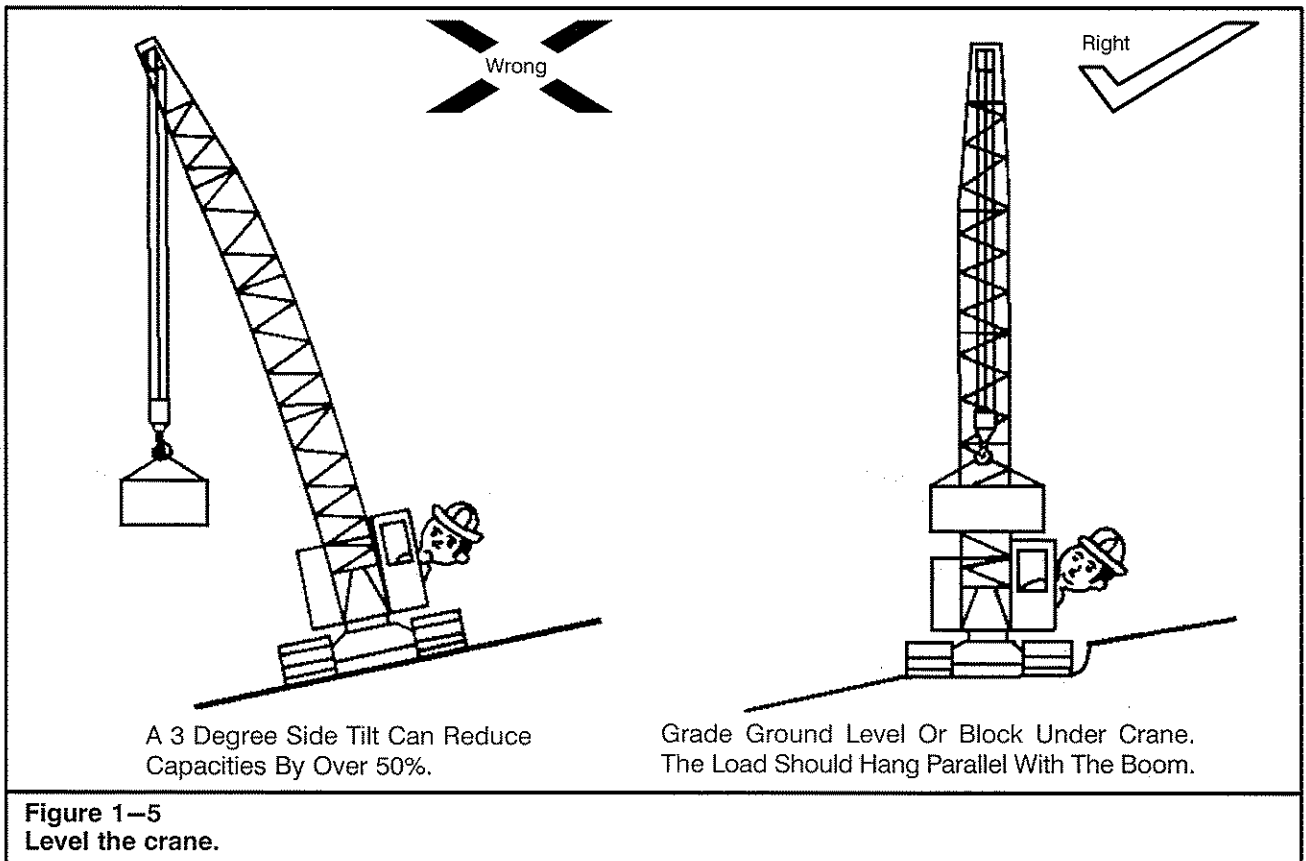

8. The operator, supervisor, or person in charge of the load must observe the following rules:
- Loads must be well secured before lifting. Ensure that the rigging cannot slip off or pull away from the load, or get out of position on the load. Ensure the load is rigged so it will not turn over.
 - Chains and slings must be of adequate size, in good condition, and not twisted around each other.
 - The crane must be on a firm level surface before making a lift. Use the bubble level to help to determine when the crane is level. Check its accuracy frequently with a carpenter's level. Remember, a three degree side tilt can reduce capacities by 50% or more.

The hook block or hook ball and hoist wire rope can be used as a "plumb bob" to level a crane. Pick up a compact load 2,000–3,000 lb (907–1 360kg) a few inches (cm) above the ground. If crane is level, hoist wire rope will hang directly between the boom foot. Now swing over the side. The lines should still hang directly between the boom foot. Be extra careful when using this method on a windy day.

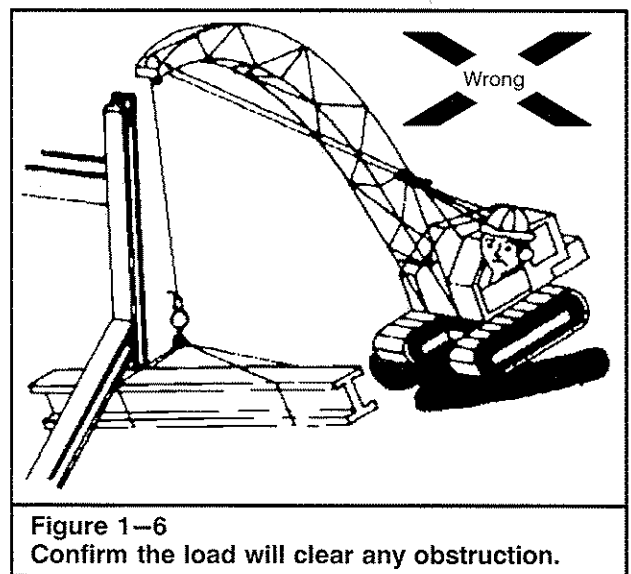

- The load must not catch on an obstruction when lifting or swinging. Ensure the load, hoist wire rope, or any other parts of the crane do not snag or strike any obstruction.

Operator's Manual

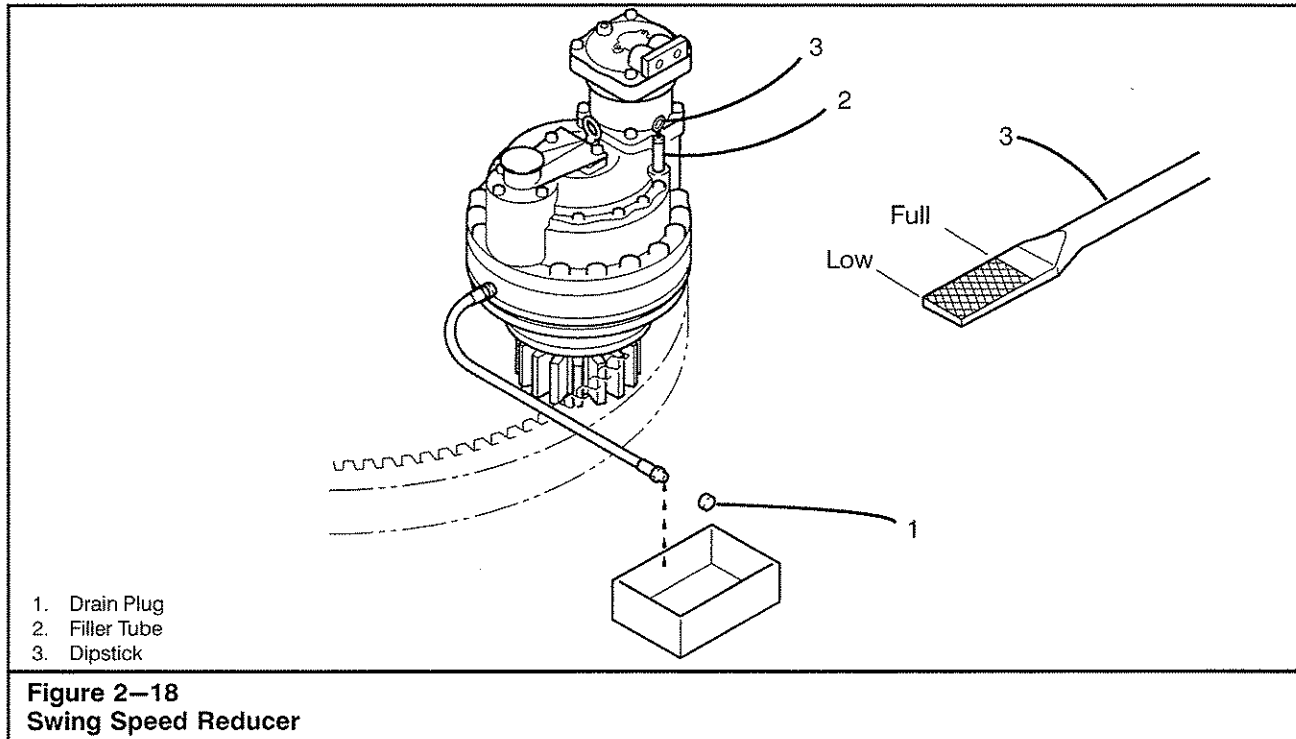

Swing Speed Reducer Lubrication

Check the oil level in the swing speed reducer after every 250 hours of operation. Thereafter, change the oil with each 1000 hours of operation or seasonally, whichever occurs first.

Swing Speed Reducer Oil Level Check

1. Park the crane on a firm level surface.
2. Position the upper directly over the front or rear of the lower, engage the travel swing lock, and shutdown the engine. Refer to Figure 2-18.
3. Wipe the dipstick handle area clean and remove the dipstick from the filler tube.
4. Wipe all the oil from the dipstick and place it back into the filler tube.
5. Remove again and read the oil level on the dipstick. The oil level should be to the "FULL" mark on the dipstick. Refer to Figure 2-18.
6. Add oil as required through the filler tube. Use only the oil type specified on the Lubrication Chart. Do not overfill.
7. Once the proper oil level is obtained, install the dipstick in the filler tube.

Swing Speed Reducer Oil Change

1. Park the crane on a firm level surface.
2. Swing the upper for several minutes, to agitate and warm the oil within the swing speed reducer.
3. Position the upper over the front or rear of the lower, engage the travel swing lock, and shutdown the engine.
4. Thoroughly clean the exterior surface of the swing speed reducer around the dipstick handle area to prevent contamination from entering the unit. Refer to Figure 2-18.
5. Remove the dipstick and drain plug and allow the oil to drain into a suitable container. Inspect the oil for large quantities of metal particles. After the initial oil change, this is a sign of damage or major wear within the unit, and a complete internal inspection may be necessary.
6. After the oil has thoroughly drained, clean and install the drain plug.
7. Fill the unit with oil through the filler tube to bring the oil level to the "FULL" mark on the dipstick. For the correct grade and quantity of oil, refer to the Lubrication Chart.
8. Properly dispose of the used oil.

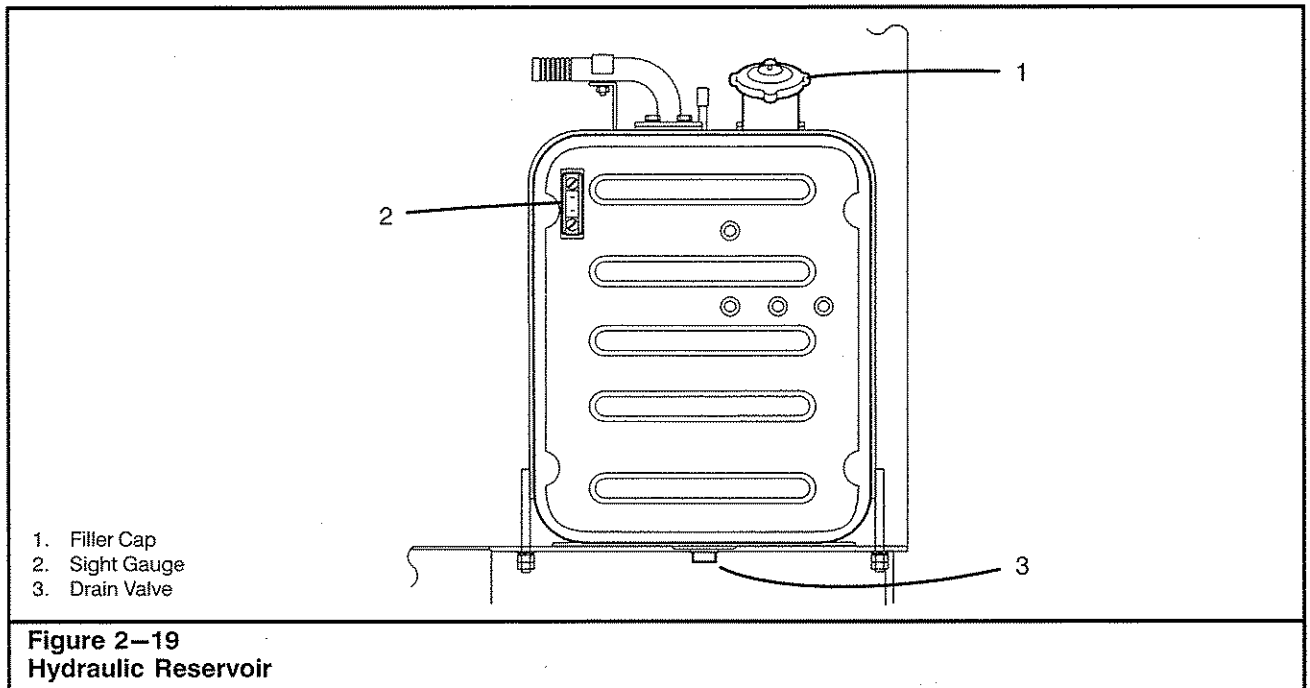

Hydraulic Reservoir

The hydraulic reservoir is used to supply and store hydraulic oil needed to operate all hydraulic functions of the crane. The hydraulic reservoir, as shown in Figure 2–19, is equipped with a sight gauge for checking the oil level.

Drain any water from the hydraulic reservoir and check the oil level daily. Operating the crane with the oil level below the full mark or with water in the system can lead to hydraulic component failure. The system's pressure and return filters should be changed initially after 50 hours of operation. Thereafter, change the filters with each 500 hours of operation. The hydraulic reservoir oil should be checked every 10 hours of operation and changed after every 1,500 hours of operation or seasonally, whichever occurs first. Refer to the following procedures when servicing the hydraulic reservoir.

Water Drain

Drain the water from the hydraulic reservoir daily before start up. Contaminated oil will damage the hydraulic system components.

1. Properly park the crane on a firm level surface.
2. Position the upper over the front or rear of the lower, apply the travel swing lock, and shutdown the engine. Allow the hydraulic oil to cool.
3. Relieve any trapped hydraulic pressure from the system by working the crane controls back and forth several times until the hydraulic pressure gauge in the operator's cab reads zero.

WARNING

All trapped hydraulic pressure must be exhausted from the system before removing any plug or cover. A sudden release of hot oil could cause serious burns or other serious injury. Allow the oil within the reservoir to cool before opening drain valve.

4. Remove the house access panel, mounted directly below the hydraulic reservoir, to gain access to the reservoir drain valve. Refer to Figure 2–19.
5. Place a suitable container under the drain valve. Open the valve and allow the water to drain into a suitable container.
6. When a clean flow of hydraulic oil begins to drain from the drain valve, close the valve.
7. Check the oil level in the hydraulic reservoir before beginning operation of the crane. Add oil if necessary. Properly dispose of the contaminated water.

Hydraulic Reservoir Oil Level Check

1. Properly park the crane on a firm level surface.
2. With all hydraulic cylinders fully retracted, position the upper over the front or rear of the lower, apply the travel swing lock, and shutdown the engine.
3. Check the level through the sight gauge on the front of the hydraulic reservoir. Refer to Figure 2–19.

Operator's Manual

4. Add hydraulic oil to bring the oil level slightly above the midpoint between the "H" and "L" marks on the sight gauge. Refer to "Adding Oil To The Hydraulic Reservoir" following this procedure for the correct instructions.

Adding Oil To The Hydraulic Reservoir

1. Properly park the crane on a firm level surface.
2. With all upper hydraulic cylinders fully retracted, position the upper over the front or rear of the lower, apply the travel swing lock, and shutdown the engine.
3. Relieve any trapped hydraulic pressure from the system by working the crane controls back and forth several times until the hydraulic pressure gauge in the operator's cab reads zero.



WARNING

All trapped hydraulic pressure must be exhausted from the system before removing any plug or cover. A sudden release of hot oil could cause serious burns or other serious injury.

4. Clean the top of the hydraulic reservoir and filler cap to prevent foreign material from entering the hydraulic system.
5. Remove the filler cap.
6. Add hydraulic oil to bring the oil level slightly above the midpoint between the "H" and "L" marks on the sight gauge.
7. Install filler cap.

Hydraulic Reservoir Oil Change

Change the hydraulic reservoir oil at the end of a working day when any foreign particles will be suspended in the warm oil. If this is not possible, cycle the crane until the oil is warm and proceed as follows:

1. Properly park the crane on a firm level surface.
2. With all upper hydraulic cylinders fully retracted, position the upper over the front or rear of the lower, apply the travel swing lock, and shutdown the engine.
3. Relieve any trapped hydraulic pressure from the system by working the crane controls back and forth several times until the hydraulic pressure gauge in the operator's cab reads zero.



WARNING

All trapped hydraulic pressure must be exhausted from the system before removing any plug or cover. A sudden release of hot oil could cause serious burns or other serious injury.

4. Remove the house access panel, mounted directly below the hydraulic reservoir, to gain access to the system drain valve. Refer to Figure 2-19.
5. Thoroughly clean the exterior surface of the hydraulic reservoir, around the filler cap, and drain valve to prevent foreign materials from entering the system.
6. Remove the filler cap and pump the hydraulic oil into suitable containers. Refer to the Lubrication Chart to determine the volume of oil to be removed.

Note: If a pump is not available to remove the oil from the reservoir, place a suitable container under the drain valve. Open the valve and drain one container full at a time, until the oil has thoroughly drained from the reservoir.

7. Open the drain valve and allow any remaining oil in the reservoir to drain into a suitable container.
8. Inspect the oil for large quantities of metal particles. After the initial oil change, this is a sign of excessive hydraulic component wear or damage.
9. Close the drain valve.
10. Replace the hydraulic system pressure and return filters. Refer to the appropriate procedures given in this Section of this Operator's Manual.
11. Add hydraulic oil to bring the oil level slightly above the "H" and "L" marks on the sight gauge. Refer to "Adding Oil To The Hydraulic Reservoir" in this Section of this Operator's Manual for the correct instructions.
12. Start the engine and move the gate lock lever to the "Close" position. Allow the engine to idle several minutes to ensure oil is being cycled properly. Check for any leaks.
13. Recheck the oil level in the hydraulic reservoir for proper level. Add oil if necessary. Properly dispose of the used oil.

Note: In case of hydraulic system component failure, a more thorough oil change procedure is required. Contact your Link-Belt Distributor for this procedure.

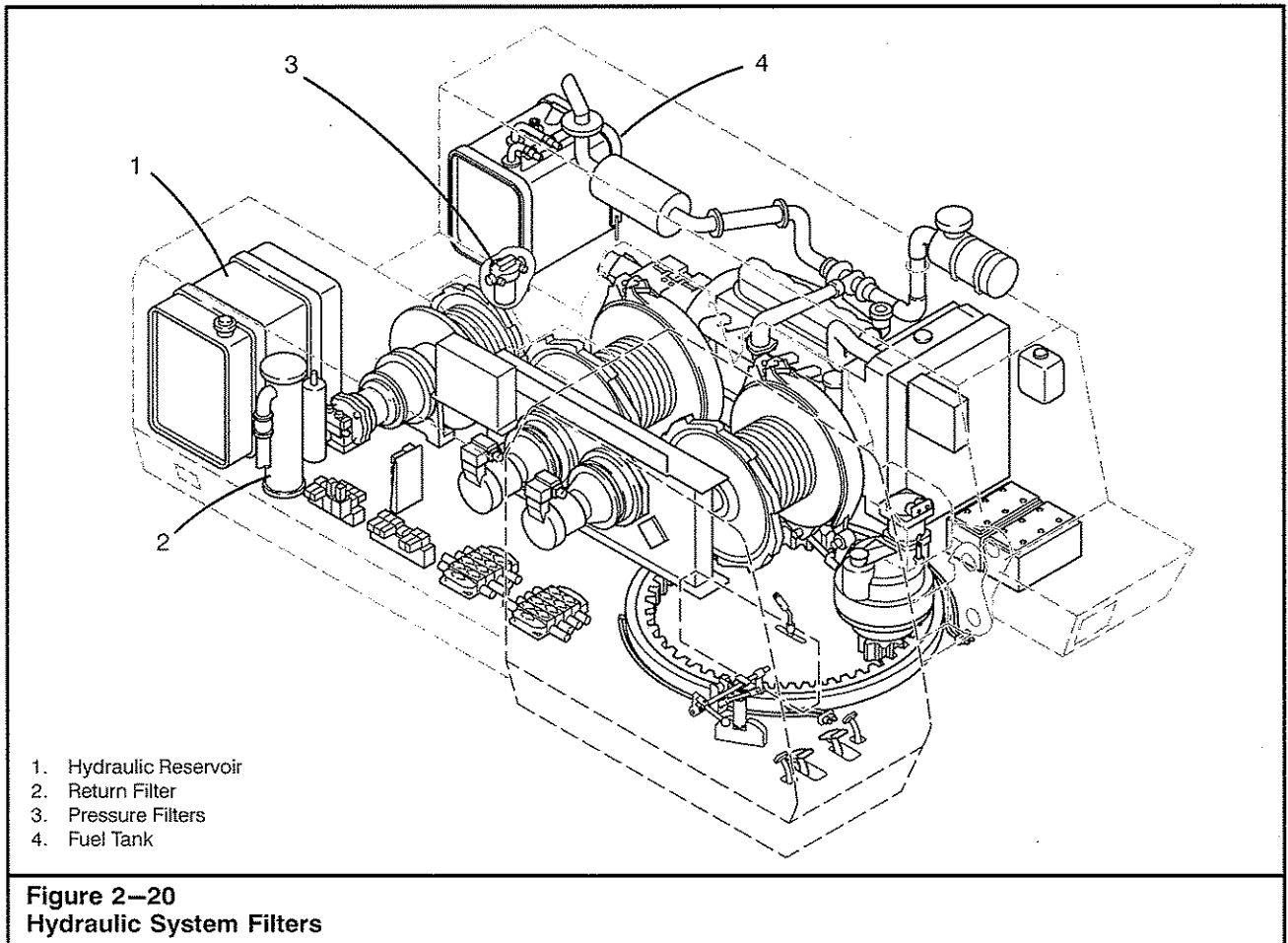

Hydraulic System Filters

The upper hydraulic system utilizes two pressure filters and one return line filter to continuously clean the oil during operation. These filters are shown in Figure 2-20. Change all the hydraulic system filter elements after the initial 50 hours of operation and every 500 hours of operation thereafter. Refer to the following procedures when changing the hydraulic system filter elements.

Hydraulic System Pressure Filter Change

1. Properly park the crane on a firm level surface.
2. Position the upper over the front or rear of the lower, apply the travel swing lock, and shutdown the engine.



WARNING

All trapped hydraulic pressure must be exhausted from the system before removing any plug or cover. A sudden release of hot oil could cause serious burns or other serious injury.

3. Relieve any trapped hydraulic pressure from the system by working the crane controls back and forth several times until the hydraulic pressure gauge in the operator's cab reads zero.
4. Position an appropriate container under the filter assembly. Clean the filter housing and head assembly to prevent contamination from entering the system. (Refer to Figure 2-20 for location of the pressure filters.)
5. Loosen the filter housing from the head assembly and allow any oil in the filter assembly to drain into the container. Refer to Figure 2-21.
6. Remove the filter housing and element.
7. Remove the bypass valve, o-ring, and back up ring from the head assembly. Check that the bypass valve has an opening pressure of 15 psi ($1.05\text{kg}/\text{cm}^2$). Clean or replace as required.
8. Properly discard the filter element, o-ring, and back up ring. Clean the filter housing and head assembly with an approved solvent.
9. Install new back up ring, o-ring, and bypass valve in the head assembly.

Operator's Manual

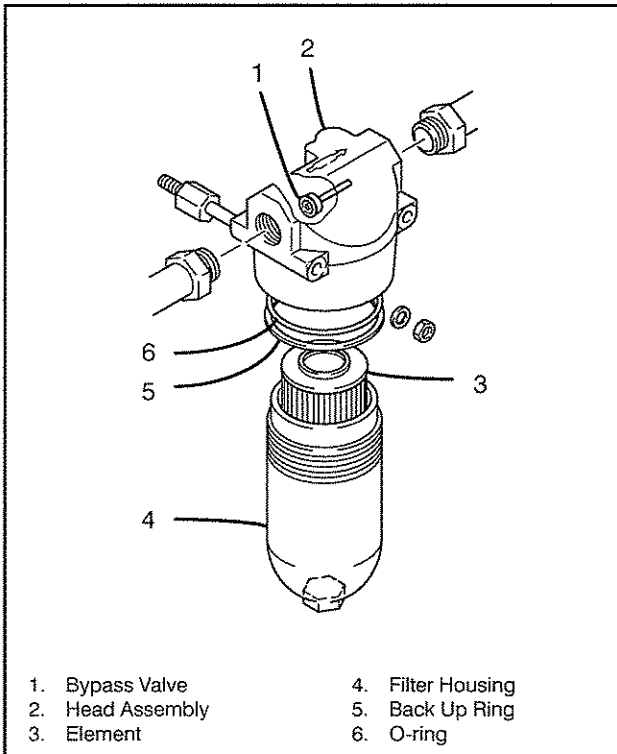

- | | |
|------------------|-------------------|
| 1. Bypass Valve | 4. Filter Housing |
| 2. Head Assembly | 5. Back Up Ring |
| 3. Element | 6. O-ring |

Figure 2-21
Hydraulic System Pressure Filters

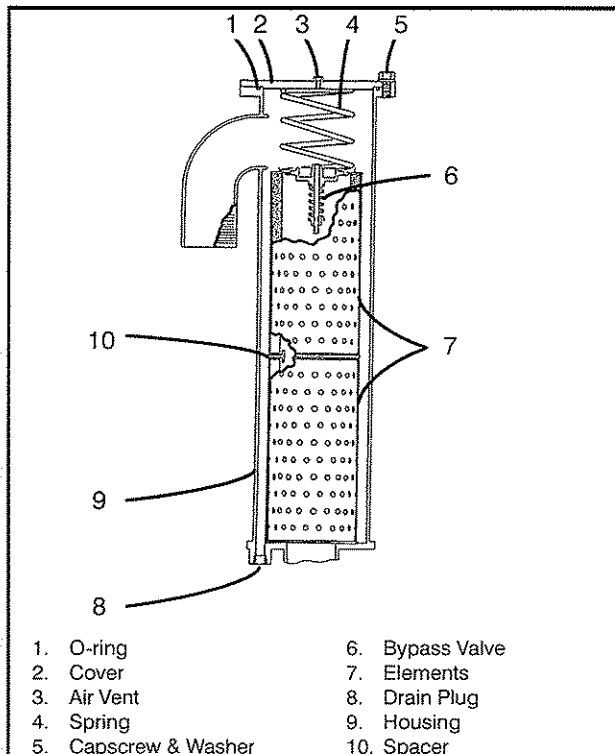

- | | |
|----------------------|-----------------|
| 1. O-ring | 6. Bypass Valve |
| 2. Cover | 7. Elements |
| 3. Air Vent | 8. Drain Plug |
| 4. Spring | 9. Housing |
| 5. Capscrew & Washer | 10. Spacer |

Figure 2-22
Hydraulic System Return Filter

10. Insert the new filter element into filter housing. Install the filter housing to the head assembly.
11. Start the engine and inspect the system for leaks.
12. Shutdown the engine and check the oil level in the hydraulic reservoir. Refer to "Hydraulic Reservoir Oil Level Check" in this Section of this Operator's Manual for specific instructions.
13. Properly dispose of the used oil and element.

Hydraulic System Return Filter Change

1. Properly park the crane on a firm level surface.
2. Position the upper over the front or rear of the lower, apply the travel swing lock, and shutdown the engine.
3. Relieve any trapped hydraulic pressure from the system by working the crane controls back and forth several times until the hydraulic pressure gauge in the operator's cab reads zero.



WARNING

All trapped hydraulic pressure must be exhausted from the system before removing any plug or cover. A sudden release of hot oil could cause serious burns or other serious injury.

4. Position an appropriate container under the filter assembly. Clean the filter housing air vent and drain plug to prevent contamination from entering the system. (Refer to Figure 2-20 for location of the return filter.)
5. Slowly open the air vent. Refer to Figure 2-22.
6. Remove the filter housing drain plug and allow the oil to drain into the container.
7. Evenly loosen the capscrews and washers which secure the filter housing cover. Carefully remove the cover and o-ring.



WARNING

The filter housing cover is used to retain a spring under tension. Evenly remove the capscrews and washers which secure the cover to relieve tension on the spring.

8. Remove the spring and bypass valve from the top of the filter element within the housing.
9. Remove the filter elements from the housing. Separate the two elements and save the spacer.
10. Clean the inside of the filter housing.
11. Install a new filter element in the housing, position the spacer and install the second filter element.

Operator's Manual

12. Clean and install the drain plug. Fill the filter housing with hydraulic oil.
13. Inspect the bypass valve and o-ring for damage or wear. Clean or replace as required.
14. Install the bypass valve, spring, and o-ring in the filter housing.
15. Install the housing cover using the capscrews and washers. Close the air vent.
16. Start the engine and inspect the system for leaks.
17. Shutdown the engine and check the oil level in the hydraulic reservoir. Refer to "Hydraulic Reservoir Oil Level Check" in this Section of this Operator's Manual for specific instructions.
18. Properly dispose of the used oil and elements.

Boom And Jib Inspection And Lubrication

Inspect all parts of each boom and jib section daily. Pay particular attention to the chords and lattice. Refer to Figure 2-23. If any dents, bends, cracked welds, etc. are found, do not use the damaged section. Contact your Link-Belt Distributor for repair procedures.



WARNING

Do not use a boom or jib section which has been damaged. The structural integrity of the section is lost and the attachment could collapse with or without a load. Use the damaged section only after it has been properly repaired and passed a thorough inspection.

Lubricate the deflector rollers and other parts of the boom, jib, and live mast as specified on the Lubrication Chart.



WARNING

To avoid personal injury, do not climb, stand, or walk on the boom or jib. Use a ladder or similar device to reach necessary areas.

Wire Rope Lubrication

Wire rope is like a machine. Each time a wire rope bends over a sheave or straightens from a slack position many wires move against each other. Lubrication is necessary to help prevent wear caused by this movement. Lubrication also helps prevent deterioration of wire rope due to rust and corrosion.

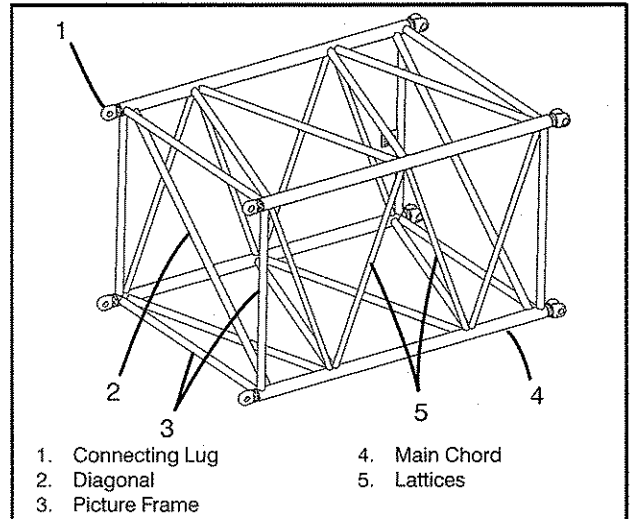

Figure 2-23
Boom Section Nomenclature



WARNING

Keep all wire rope well lubricated to minimize wear and prevent corrosion. Rusty wire rope is dangerous since there is no way to determine its remaining strength and reliability.

Most wire ropes are lubricated during manufacture, but the lubricant does not last the life of the wire rope.

The lubricant is squeezed out of the wire rope as it runs over sheaves under tension, or washed off by rain.

For the above reasons, wire rope must be periodically lubricated. Crude or used oils and grease should not be used as lubricants because they may be grit or acid laden. Either of these conditions can cause damage to the wire rope.

No set rule can be given for lubrication frequency. This will depend on the type of conditions under which the wire rope is used.

A wire rope used in wet conditions will need to be lubricated more often to prevent rust and corrosion than one used in dry conditions.

Lubricants used for wire rope lubrication should have the following properties:

1. They must not contain acids or alkalis.
2. They must have enough adhesive strength to stay on the wire rope.
3. They must be able to penetrate between the wires and strands.
4. They must have high film strength.
5. They must resist oxidation.
6. They must remain soft and pliable.

Operator's Manual

Application Of Wire Rope Lubricant

Wire ropes that have been in service should be cleaned before relubricating them. Use a wire brush and compressed air to clean the wire rope. All possible foreign material and old lubricant should be removed from the wire rope before relubricating it. Use one of the following methods to apply the lubricant.

1. Continuous Bath

Run the wire rope through a container filled with lubricant. A sheave mounted in the center of the container will hold the wire rope submerged as it passes through the container. Use swabbing to remove excess lubricant as the wire rope leaves the container.

2. Dripping

Place a container above a sheave so a spigot can be opened to drip oil on the wire rope as it passes through the sheave groove.

3. Swabbing And Painting

Two fast methods are swabbing the lubricant on with rags or painting it on with a brush.

4. Spraying

Light lubricants may be applied with a spray gun. Aerosol cans of lubricant are also available.

Crane Monitoring System

Maintenance of the Crane Monitoring System consists of the following daily inspection prior to the first operation:

1. Check that the system is operating normally as described in the manufacturer's operator's manual.
2. Check the electrical cables connecting the various parts of the system.
3. Check insulation on the boom reeling drum cable.
4. Check boom reeling drum cable for proper tension.
5. Check the anti-two block boom switches for freedom of movement.
6. Check that the anti-two block weights are installed and working properly with the anti-two block switches.
7. Test that the function limiters activate properly by two blocking the crane. (Do this by manually lifting the ATB weight.)
8. On cranes equipped with a tensiometer in the system, lubricate the sheaves on the tensiometer every 10 hours of operation.

Check the following every 30 days.

1. Check that the displayed boom angle, boom length, and the operating radius displays agree with the measured readings.

2. If a known test weight is available, check that the displayed weight agrees with the test load. The displayed load includes the hook block/hook ball and any lifting attachments such as slings, pins, and shackles.
3. If the capacity chart in the Crane Rating Manual is rated for specific areas e.g. side, front, or rear, the system should be checked by swinging the boom into the permitted areas and checking that the rated capacity reading agrees with the capacity chart in the Crane Rating Manual.



WARNING

Any unusual or erratic system operation must be investigated and corrected immediately. If any problem is found with any of the above inspection steps, the problem must be corrected/repared before continuing operation.

Hydraulic Hose Assembly Inspection

The frequency of inspection and replacement of hose assemblies should be determined by the operating environment, the potential risk from a hose failure, and past experience of hose failures in the application and environment.



WARNING

Always wear safety glasses when working with or inspecting pressurized hose assemblies. Do not search for leaks by running your hand or finger along a hydraulic hose. Hot hydraulic oil, under high pressure leaking through a small pin size hole in a hose, can puncture gloves, your skin, and penetrate several inches (centimeters) into soft body tissue causing serious personal injury.

A daily visual inspection is recommended for all hose assemblies in service.

1. Check all hose end fittings for cracks, crushing, corrosion, slippage on the hose, leakage, or any other damage.
2. Check all hoses for cracks, exposed reinforcement, chafing, bulging, loose covers, or any other damage.
3. Check the installation of all hose assemblies for any kinked, crushed, flattened, or twisted hoses.

Replace any damaged hose assemblies, hose end mating fittings, and seals as required.

Operator's Manual

Hook Block, Hook Ball, And Swivel Inspection And Maintenance

1. All nuts, setscrews, pins, bolts, and retainers should be checked for tightness every 14 to 30 days, depending on the operating conditions and the product involved.
2. Inspect the components carefully at least once a month.

Swivels: Check for excessive gap distance between the rotating parts. Check threaded parts that are installed together to see that they are secure and tight. Check all setscrews to see that they are tight and staked.

Hook Blocks: Check all pins and bolts for tightness, spreading of side plates, weld cracks, sheave wear, bearing wear, spreading of hook, setscrews that are tight and staked. Check that hook latch is operative.

Hook Balls: Check pin, nut, and washer to ensure ball halves are held securely together. Check locating pin for excessive wear. Inspect swivel parts as specified previously. Check that hook latch is operative.

3. If a swivel is constantly overloaded, it will cause damage to the unit. The first sign of damage is often bearing brinelling (dimpling of the bearing races). This condition is determined by spinning the swivel by hand. If the motion is rough, or has a ratchet-like effect, the bearing has been damaged and should be replaced.
4. The distance between the swivel barrel and shank or rotating members are preset with a factory clearance of .020—.050 in (.05—.13cm). If this distance increases more than .060 in (.15cm) over the above distance, it is a good indication of bearing fatigue and the unit should be removed from service.

Lubrication Frequency		
Item	Under Intermittent Operating Conditions	Under Continuous Operating Conditions
Swivels, Swivel Overhaul Balls, Swivel Hook Balls	14 days	24 hours
Hook Blocks with Bronze Bushed Sheaves	14 days	8 hours
Hook Blocks with Roller Bearing Sheaves	14 days	24 hours

Inspection Frequency			
Item	Frequency	What to Check For	Appropriate Action
Swivels	14 days under continuous operation	End play or gap of more than .06 in (.15cm) along the axis.	Remove from service immediately.
	30 days under intermittent operation	Rough turning.	Defective bearing. Remove from service immediately.
		Elongated eye holes, bent clevis pins.	Indicates overload. Remove for repairs.
Sheaves	14 days under continuous operation	Misalignment, as evidenced by wobble or uneven groove flange wear.	Indicates major bearing wear. Remove from service.
	30 days under intermittent operation	Striations or corrugations in sheave groove.	Check for wear in bronze spacers where used. Result of wire rope wear. If major, replace.
Hook Latch	When Used	Missing, off center, bent, broken spring, or defective.	Replace immediately
Hooks	Daily or When Used	Permanent deformation or stretching.	An indication of overload. Replace. Any suspicion of fractures calls for an immediate investigation and, if necessary, replacement of part.
		Crack or other defects.	Hooks should be tested at least once a year by magnafluxing, x-ray, or other qualified method. Intermittent tests can be conducted by a less accurate oil stain method.

Operator's Manual

Air Conditioning Inspection And Maintenance





	Sight Glass	Coolant Level	 <p>1. Receiver Tank 2. Condensor 3. Sight Glass</p>
Sufficient		The are scarcely any bubbles in the fluid.	
Insufficient		Bubbles are found in the fluid. (Bubbles pass the window continually.)	
Overfilled Or Void		No bubbles are seen through the sight glass.	

Figure 2–24
Coolant (Gas) Volume Inspection

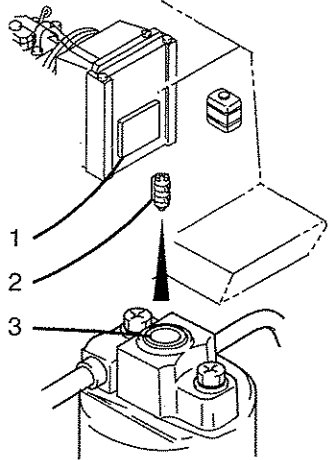

1. Inspect and clean condenser fin. Remove any foreign particles from the condenser. A clogged condenser may decrease the cooling capacity.

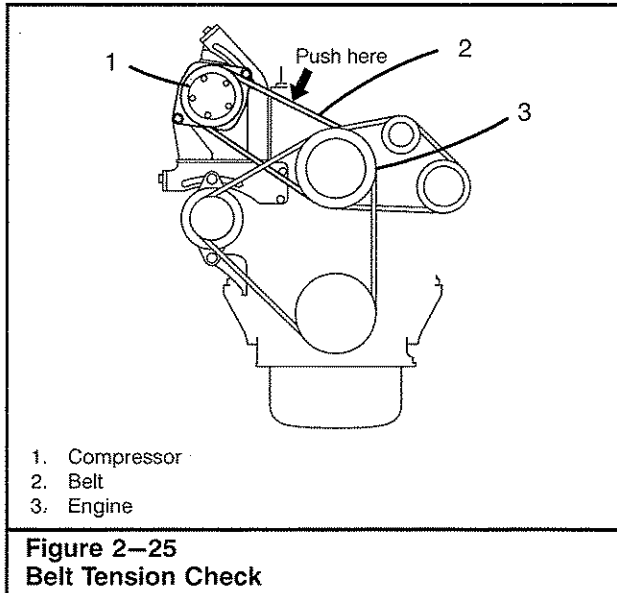

WARNING

Use only R134a refrigerant in air conditioning system. Use of any other refrigerant will damage the system.

2. Check the coolant volume through the sight glass. Use the information in Figure 2–24 to visually check sight gauge and make necessary adjustments to the cooling system.
3. Inspect belt tension. Adjust belt tension so the belt deflects approximately 0.2 in (5mm) when 8 lb (3.6kg) of pressure is applied in the area shown.

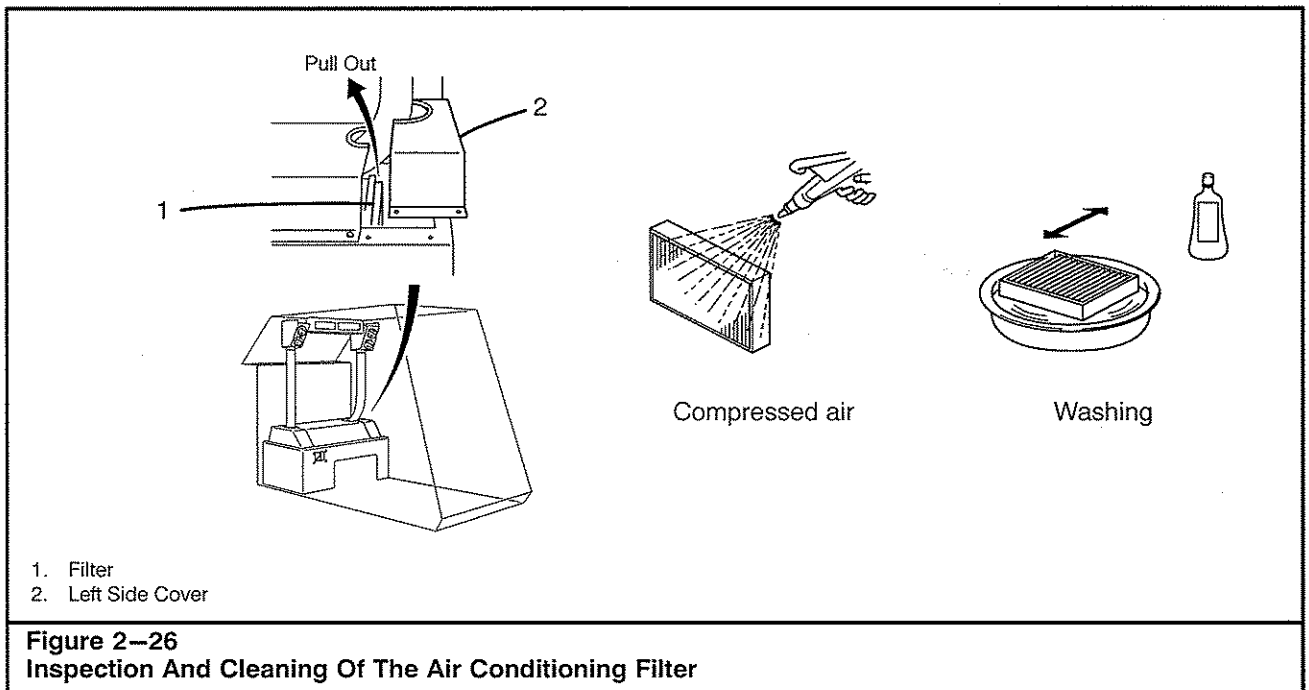

Air Conditioning Filter

The filter should be inspected on a monthly basis. A restricted filter may result in decreased air volume and deterioration of air conditioning capacity. Remove the left side cover (rear of the Operator's seat) and remove the filter. Lightly soiled filters may be cleaned with compressed air. Highly soiled filters should be cleaned using a neutral detergent and allowed to thoroughly air dry.

Compressed Air

Hold an air hose nozzle at least 1 in (25mm) away from the filter element. Spray air through the element in the direction opposite to normal air flow. Move the nozzle

up and down. Use air pressure of less than 100 psi (7kgf/cm²) to prevent damage to the filter paper. Thoroughly inspect the element after cleaning.

Washing

Soak the air cleaner element for 15 minutes or more, in a neutral detergent. Thoroughly rinse the element by spraying it with a hose in the direction opposite the air flow. Use water pressure of less than 40 psi (19.4kgf/cm²) to prevent damage to the filter paper within the element. Rinse until the water is clear; air dry. Do not attempt to dry the element using compressed air or light bulbs. This may ruin the element. Thoroughly inspect the element after cleaning.

Operator's Manual

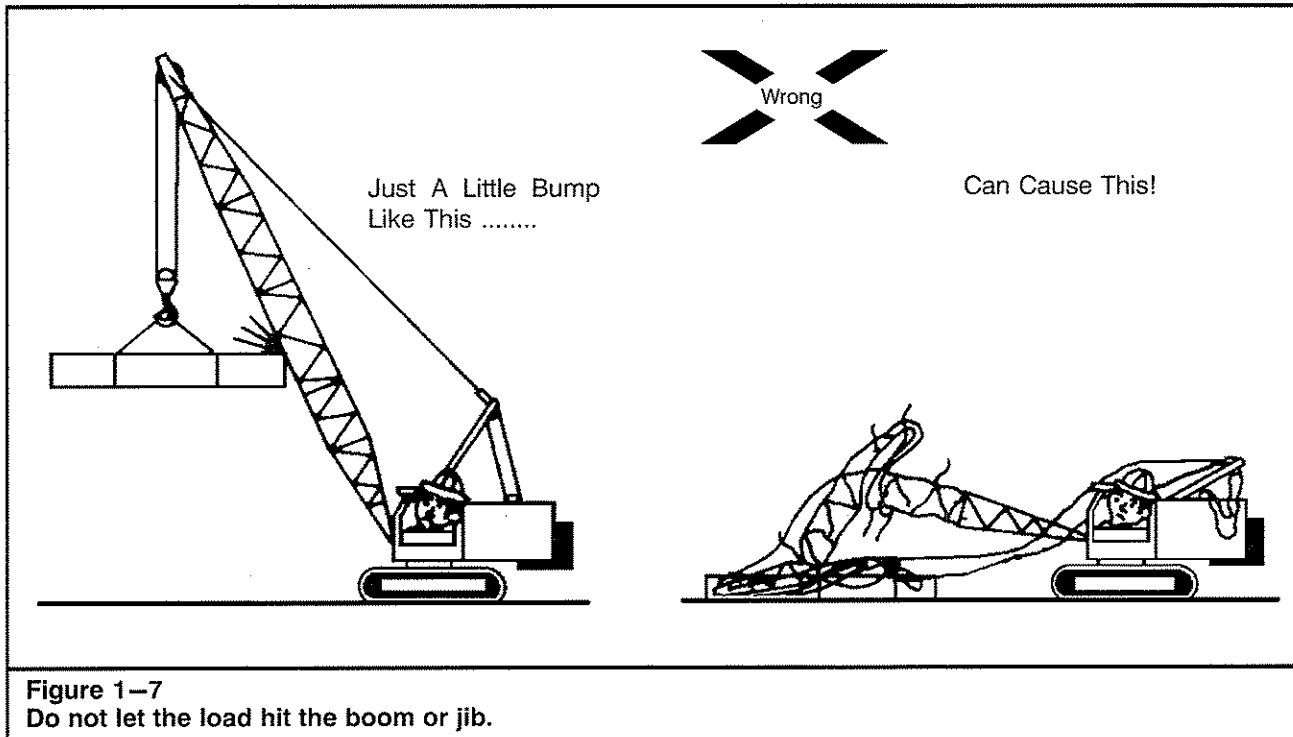

- e. Do not allow the load to rotate out of control. Personal injury to ground personnel, load damage, crane damage, or damage to anti-two block system may occur.
 - f. When hoisting with single part line, especially in long falls applications, the design of wire rope and hook ball is crucial to minimize the potential for uncontrolled wire rope and/or load rotation. Rotation resistant wire rope is recommended for single part of line applications. See the Wire Rope Capacity Chart in the Crane Rating Manual for the specific types of rotation resistant wire rope recommended for the crane.
 - g. Avoid sudden starts and stops. Lift carefully, swing gently, brake smoothly, lower and set loads carefully. Jerking the load, swinging and engaging swing brake roughly, and lowering the load rapidly and slamming on brakes, will put shock loadings and possible side loadings on the boom. Unnecessary abuse labels the operator as a beginner. Be a professional.
 - h. Do not wrap the winch wire rope around the load. Do not use discarded, worn, or damaged wire ropes for slings. They may break and drop the load.
9. Don't let the load or bucket hit the boom or attachment. Don't let the boom or attachment rest on, or hit, a building or any other object. A dent or other damage could result, which will weaken the boom or attachment. If the damage is major, the attachment could collapse. If a lattice or diagonal bracing member on the boom or jib is broken, cracked, or bent, contact your Link-Belt Distributor for repair procedures. If the boom or attachment is struck or damaged by anything, STOP. The loading on a boom or attachment increases as they are lowered, therefore their suspension systems could collapse during lowering. Use another crane to lower a damaged boom or attachment.

Operator's Manual

Turntable Bearing Capscrew Torque

Proper tightening of turntable bearing capscrews is very important. If the bearing has been replaced or the crane undocked for any reason, capscrews should be replaced. Reuse of capscrews is not recommended.

CAUTION

Loctite pipe sealant is used on the turntable bearing capscrews. The Loctite pipe sealant seals the threads to prevent rust and corrosion.

Capscrews should be inspected and/or torqued after the first 250 hours of operation. Inspect and/or torque capscrews every 500 hours of operation thereafter. Torque capscrews to 352–381 ft lb (477–517Nm).

Paint Maintenance

Knowledgeable equipment owners realize the value of periodic preventative maintenance and responsible care. A regular surface care program should be followed to protect the equipment's paint finish and maintain a like-new appearance. There is no one correct/ultimate procedure since the uniqueness of every crane's operating environment and owner/operator maintenance habits differ. However, it is important to remove surface contaminants before they have time to bond or etch into the paint finish.

Regular Preventative Maintenance

1. Regular washing is the best way to remove surface contaminants.
2. Always use mild cleaners and soaps, and rinse thoroughly after washing. Do not use harsh detergents, such as household laundry detergents, or cleaners that contain phosphates, as they will "burn" the paint, strip off protective coating, diminish the gloss, and accelerate the contamination process.
3. Periodic waxing will enhance the luster and protect the paint surface.

If environmental damage to the paint finish is detected (loss of some of its luster due to lack of or inability to maintain as recommended) the paint finish can be restored to near-new appearance by following a simple polishing and waxing procedure.

Polishing And Waxing Procedure

1. Clean surface thoroughly by hand washing or power washing with a mild detergent. Rinse thoroughly with water before buffing.
2. Apply a polishing compound, such as Meguiar's M8432, or equivalent, to a surface area approximately two feet by two feet (.6m by .6m) at a time. Ensure the cleaner is applied liberally to entire area and work on only that area with the buffing wheel.
3. Buff surface with an electric or air buffer at 1000 rpm using a 3M Superbuff polishing pad, or equivalent, with light to medium pressure until a uniform high gloss is obtained. Hand wipe with a clean cloth.
4. After surface has been buffed, apply a quality automotive wax such as Meguiar's M-26 Hi-Tech Yellow Wax, or equivalent, and hand buff until the cloth moves freely. The original luster of coating should be restored.

Operator's Cab Console Cleaning

Care should be taken when cleaning the operator's cab console, especially the new polycarbonate consoles. If the incorrect cleaning agent is used, the finish of the material could be destroyed. It is recommended that only the following materials be used for cleaning:

1. Soap and water
2. Denatured alcohol
3. Joy and Palmolive dishwashing liquids
4. Windex with Ammonia D
5. Formula 409, Fantastik, Mr. Clean

Operator's Manual

Table Of Contents

Track Tension Adjustment	3-1
To Increase Track Tension	3-1
To Decrease Track Tension	3-1
Front, Rear, And Fourth Drum Brakes	3-2
Automatic Brake Adjustment	3-2
Band Brake Adjustment	3-3
Brake Band Inspection	3-3
50 Hour Inspection	3-4
250 Hour Inspection	3-4
500 Hour Inspection	3-4
Brake Pedal Free-Fall Switch Adjustment	3-5
Winch Drum Clutches	3-6
Drum Clutch Inspection	3-7
Bubble Level	3-8
Bubble Level Adjustment	3-8
Crane Monitoring System	3-9
Hydraulic System Relief Valve Adjustment	3-9
Preparing the Crane For Checking Relief Pressures	3-9
Relief Valve Pressure Checking Instructions	3-9
Travel Circuit Adjusting Procedure	3-11
Boom Hoist Circuit Adjusting Procedure	3-11
Front, Rear, Third, And Fourth Drum Circuit Adjusting Procedure	3-13
Swing/Side Frame Extend/Retract Circuit Adjusting Procedure	3-14
Counterweight Circuit Adjusting Procedure	3-15
Pilot Control Adjusting Procedure	3-16

Operator's Manual

Notes:

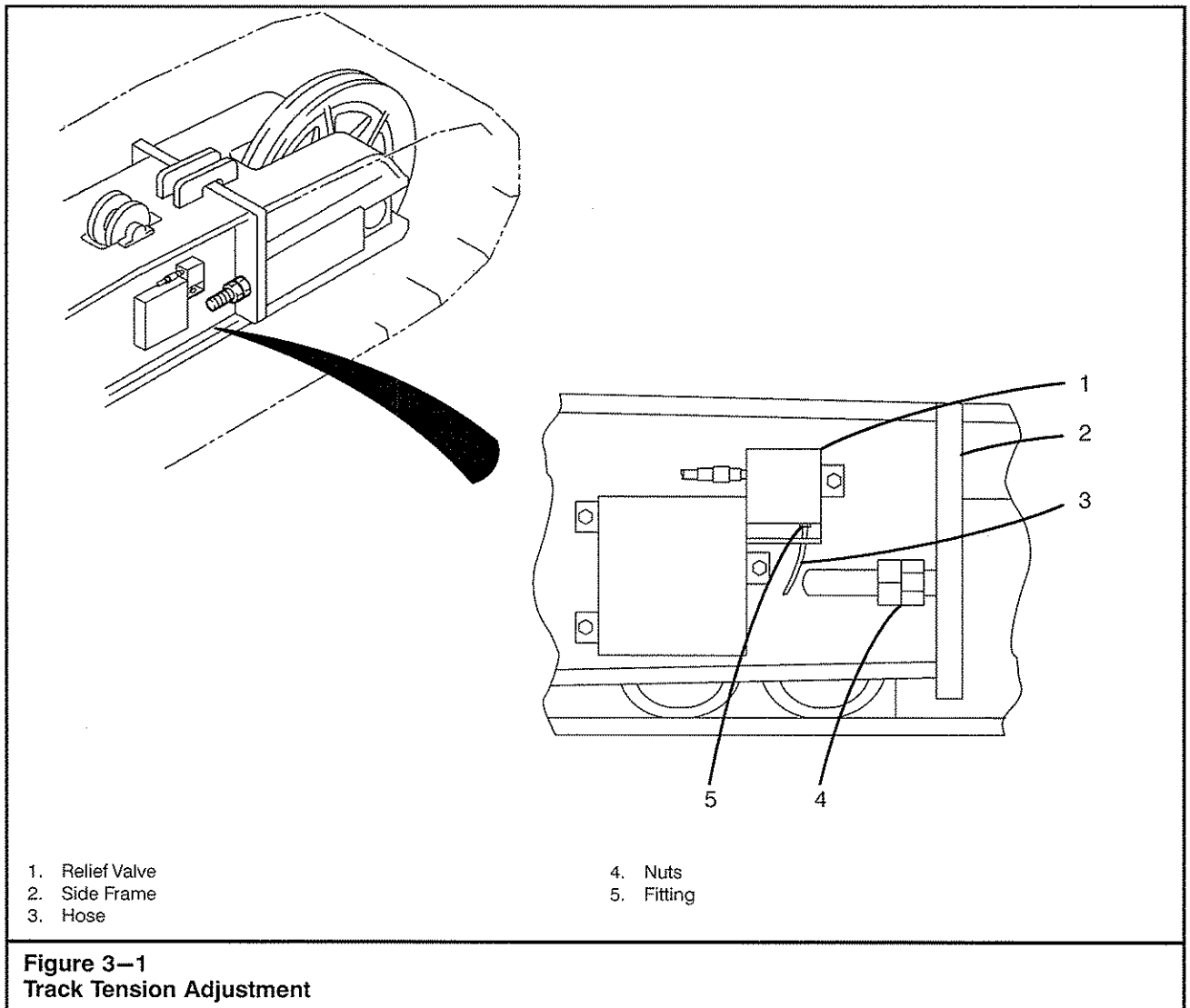

Track Tension Adjustment

Excessively loose track shoes can cause the drive sprockets to climb on the shoe lugs or the track shoes to come off the track rollers during steering. Adjust the track tension whenever necessary.

To Increase Track Tension

1. Park the crane on a firm level surface.
2. Position the upper directly over the front or rear of the lower and engage the travel swing lock.
3. Fully loosen the nuts. Refer to Figure 3-1.
4. Move the travel lever forward and backward to supply oil to the cylinder. This will tighten the track tension.
5. Tighten the nuts until they come in contact with the side frame.

6. Shutdown the engine.
7. Tighten the nut one more turn. Tighten the second nut against the first to lock it.
8. The adjustment nuts are located on the right and left on the inner and outer side of the shoe. Adjust both nuts evenly for right and left sides.

To Decrease Track Tension

1. Shutdown the engine.
2. Remove the cap from fitting. Install tubing on fitting.
3. Place a suitable container under the tubing.
4. Oil in relief valve may be under high pressure. Use caution and carefully loosen the fitting on the lower side of the check valve. Drain oil as required to loosen the tension on the shoe.

Operator's Manual

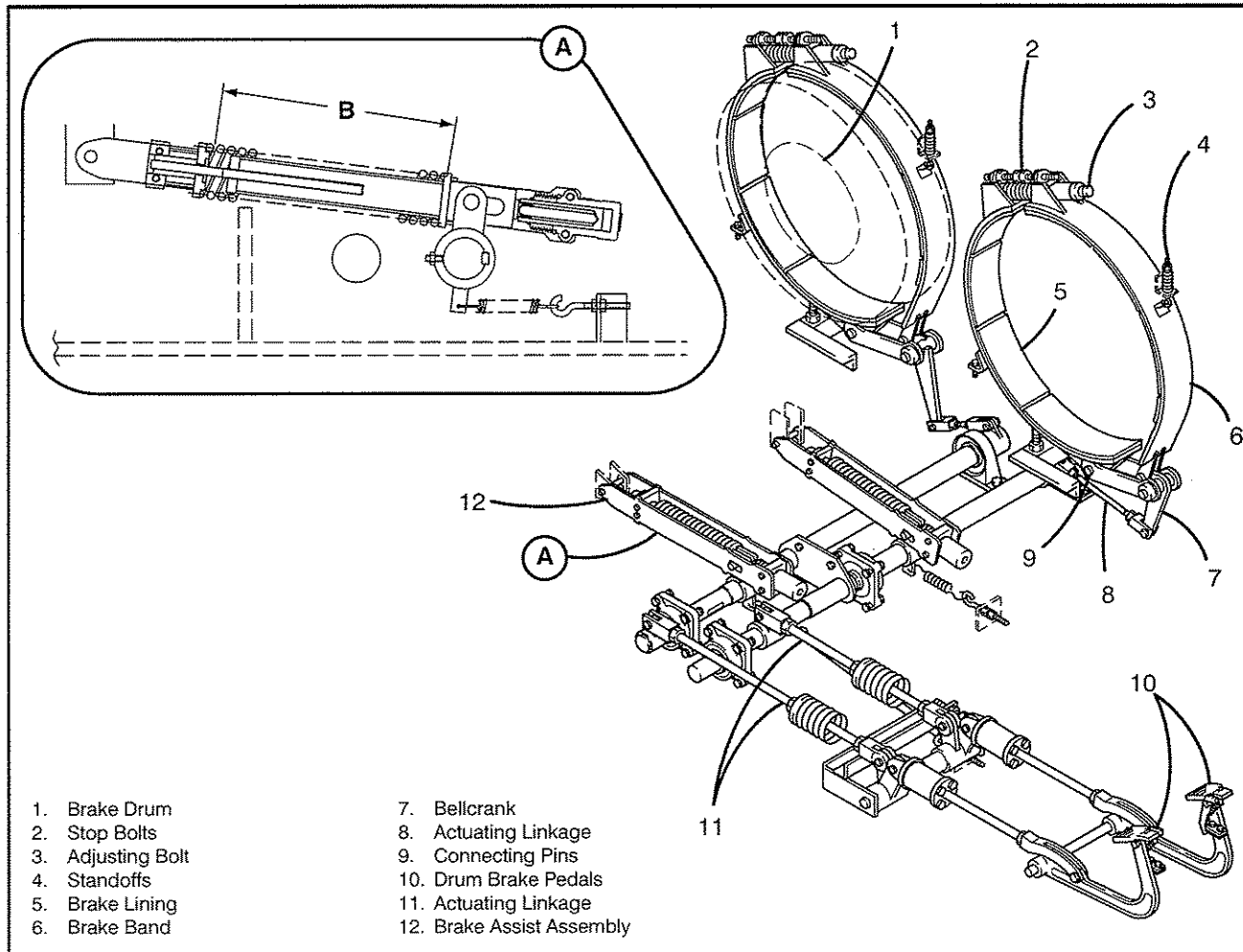

Figure 3-2
Front And Rear Drum Brakes

Front, Rear, And Fourth Drum Brakes

The winch band brake applies directly on the winch drum to control free-fall speed. It also applies automatically if hydraulic pressure is lost to stop rotation of the drum. To compensate for lining wear, linkage expansion, etc., the brake may require periodic adjustment. Check the band brake adjustment when a new crane is delivered and every 50 Hours of operation thereafter.

Brake lining wear is taken up by means of an adjusting bolt located at the split in the band. Tightening this bolt will reduce clearance between the brake band and drum, while loosening it will increase the clearance. The adjustment procedure for the front drum and the rear drum is identical.

The band should be adjusted tight enough to hold the load when the pedal is operated in the lower half of its travel. By adjusting the band in this manner, the maximum available leverage is being used. Over tightening the band will result in a much harder working brake, improper brake release, abnormal lining wear, and will make it difficult, if not impossible, to latch the pedal in the fully applied position.

This information is for preliminary adjustment only. Final criteria for correct adjustment is safe load handling.

Automatic Brake Adjustment

1. Park the crane on a firm level surface. Position the upper directly over the front or rear of the lower and engage the travel swing lock.

Operator's Manual



WARNING

Lower the hook block and/or hook ball on the ground. Hook block and/or hook ball must remain on the ground during adjustment procedure to avoid inadvertent loss of control of the rigging.

2. Lower the hook block and hook ball to the ground to prevent them from falling during the brake adjustment. Shutdown the engine.
3. Remove the winch drum covers and operator's cab floor enclosure, as required, to expose the band brake, bellcranks, and linkage.
4. Start the engine and move the drum brake mode/lever lock switches to the "FREE" mode position. Free mode indicator lights should illuminate.
5. Beginning at the winch drum brake pedal in the operator's cab, check all the brake linkage up to the band brake bellcrank for proper lubrication of pin connections, smoothness of operation, and tightness of linkage. Lubricate, tighten, or replace as required. Refer to Figure 3-2.
6. Move the brake mode/lever lock switches to the "AUTO" brake mode position. Free mode indicator lights should go off. Shutdown the engine.
7. Locate brake assist assembly on the upper frame and check dimension "B". This dimension should be between 15.75 in (400mm) and 16.14 in (410mm).

Band Brake Adjustment

8. If dimension "B" is within the range mentioned above, proceed to Step 9.

If dimension "B" is 16.14 in (410mm) or greater:

- a. Note the exact measurement taken.
- b. Start engine, latch the winch brake pedals in the fully applied position, move the drum brake mode/lever lock switches to the "FREE" mode position. Carefully release brake pedals.
- c. Loosen the stop bolts on the brake bands, and turn the adjusting bolts. Note the number of turns made.
- d. Shutdown the engine to allow the automatic brake to apply.
- e. Measure dimension "B" again.
- f. Calculate the difference between the first and second measurements at "B". Repeat steps a through e, as required, to obtain the correct dimension at "B". Tighten the stop bolts.

9. After obtaining the correct dimension at "B", start the engine and move the drum brake mode/lever lock switches to the "FREE" mode position. Free mode indicator lights should illuminate.
10. Release the drum brake pedal and adjust the standoffs around the circumference of the brake band. Uniform clearance of 0.02–0.03 inch (0.5–0.75mm) should be maintained between the brake band and brake drum.
11. Check the operation of the drum brake pedal. The band should be adjusted tight enough to hold the load when the pedal is operated in the lower half of its travel. Pedals must also hold the load in the latched position. Further adjust the band brake, as required.
12. Test the adjustment by making sure the brake will hold maximum line pull in both the "AUTO" brake mode and "FREE" mode.
13. Install the winch drum covers and operator's cab floor enclosure.
14. Repeat this procedure for the second band brake, as required and the fourth band brake if equipped.

Brake Band Inspection

To ensure safe, troublefree operation of the band brakes, periodic inspections must be made. A general visual inspection should be done each 50 hours of operation, a more thorough inspection after each 250 hours of operation, and a complete disassembly after each 500 hours of operation. Use the following instructions for inspecting the brake bands. All procedures must be carried out by a qualified technician and detailed records of the work performed must comply with OSHA record keeping practices.



WARNING

Brake Lining Fiber Warning

Older brake linings may contain asbestos fibers, a cancer and lung disease hazard. Brake linings manufactured today contain non-asbestos fibers, whose long-term effects to health are unknown. Use caution when handling either asbestos or non-asbestos materials used in brake linings. Refer to OSHA regulations for proper handling of these materials. Material Safety Data Sheets (MSDS) regarding brake lining materials can be obtained from your Link-Belt Distributor.

Operator's Manual

50 Hour Inspection

1. Park the crane on a firm level surface.
2. Lower hook block and/or hook ball to the ground. Engage the travel swing lock and shutdown the engine.
3. Remove the winch drum cover to gain access to the brake bands.
4. Inspect all actuating linkage and related pins for excessive wear and proper lubrication. Refer to Figure 3-2.
5. Inspect for any oil, grease, or abrasive particles on the friction surface of the brake linings.
6. Visually check the brake bands for indications of any bending, cracking, interference, or unusual wear of the brake linings.
7. Replace any defective parts as required for any of the above reasons.
8. Properly adjust the brake bands per "Band Brake Adjustment" in this Section of this Operators Manual.
9. Install the drum covers and/or guards.
10. Repeat this procedure for the other band brake.

250 Hour Inspection

For inspection at this interval, a qualified technician must use the proper equipment and tools to perform a more thorough inspection. The tools recommended are a good light source, solvent or degreaser, wiping cloths, bristle and wire brushes, magnifying glass, mechanic's mirror, measuring tools, etc.

1. Park the crane on a firm level surface.
2. Engage the travel swing lock.
3. Lower the hook block and hook ball to the ground to prevent them from falling during the brake inspection. Move the drum brake mode switches to the "FREE MODE" position. Shutdown the engine.
4. Remove the winch drum covers, as required, from the end of the winch drum to expose the band brake and clutch.
5. Perform all 50 hour inspections.
6. Disconnect the brake bands from the standoffs and loosen the stop bolts and adjusting bolt. Refer to Figure 3-2.
7. Disconnect the brake bands from the bellcrank and slide the brake bands off the drum.
8. Replace any defective parts as required for any of the above reasons.

9. Install the brake bands back on the brake drum and connect the bellcrank and standoffs.
10. Install the drum covers and/or guards.
11. Properly adjust the band brakes. Refer to "Band Brake Adjustment" in this Section of this Operator's Manual.

500 Hour Inspection

1. Perform all 250 hour inspections.
2. The entire braking system must be removed from the crane and completely disassembled.
3. Each component must be thoroughly cleaned of all foreign material to ensure an accurate inspection.
4. Each component must be inspected by a qualified technician with the proper equipment and tools as outlined in the 250 hour inspection in addition to training and experience with nondestructive test (NDT) methods; e.g. dye penetrant and magnetic particle inspection.
5. Visually check each brake band for any bending, indentions, or cracking. Pay particular attention to the welded area which joins the lug to the bellcrank end of the band. It is not permissible for any grind or indentation marks to run across the band in the welded area. Any grind or indentation marks must run lengthwise on the band. The edges of the band must also be smooth and free of defects. Check for elongated holes in the lugs. If any problem is found, the brake band must be replaced.
6. Check the brake linings for excessive or uneven wear and loose or missing rivets. Tighten any loose rivets. If any rivet is missing, check the rivet hole in the brake band for wear. If the rivet hole is oversized, the brake band must be replaced. If the rivet hole is not oversized, replace missing rivet.
7. Inspect all pins and bolts for excessive wear and rust, especially the thread roots and under bolt heads. If any problem is found, the hardware must be replaced.
8. Properly Install all brake parts back on the brake drum.
9. Properly adjust the band brakes. Refer to "Band Brake Adjustment" in this Section of this Operator's Manual.
10. Install the drum guards and/or covers.

Brake Pedal Free-Fall Switch Adjustment

The brake pedal free-fall switch should be adjusted anytime the free-fall function is not operating properly. If the switch is not properly adjusted, the free-fall function could activate as soon as the brake pedal is even slightly depressed.

1. Lower any load to the ground.
2. Swing the upper over the side of the lower to allow access to the bottom of the operator's cab.
3. Apply the swing (park) brake and shutdown the engine.
4. Remove the front bottom panel under the operator's cab.
5. Position the brake pedals in the fully released position.
6. Locate the free-fall switches for each drum brake pedal and disconnect them from the wire harness. Refer to Figure 3-3.
7. Set a volt OHM meter to read OHM's and attach the leads to the pins in the electrical connector of the free-fall switch to be checked.
8. Start to apply the brake pedal. The switch should be activated (continually on the volt meter) just before the pedal latches. If this does not happen adjust the switch actuating arm until the switch activates.
9. Remove the volt OHM meter and reconnect the switch to the wire harness.

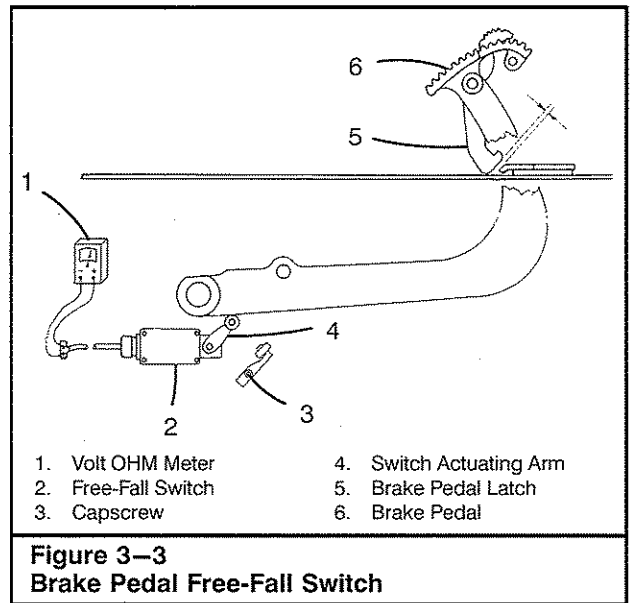

10. Repeat the above procedure for all of the winches on the crane.
11. Verify the correct operation of the free system.
 - a. Properly start the engine.
 - b. With the switch in the "AUTO" brake mode, fully release the brake pedal.
 - c. With the brake pedal fully released, move the switch to the "FREE" mode.
 - d. Slowly apply the pedal and note when the free-fall system is activated. This should happen just before the pedal latches. There will be a noticeable difference in the feel of the brake pedal and the sound of the auto brake actuator will be heard.

Operator's Manual

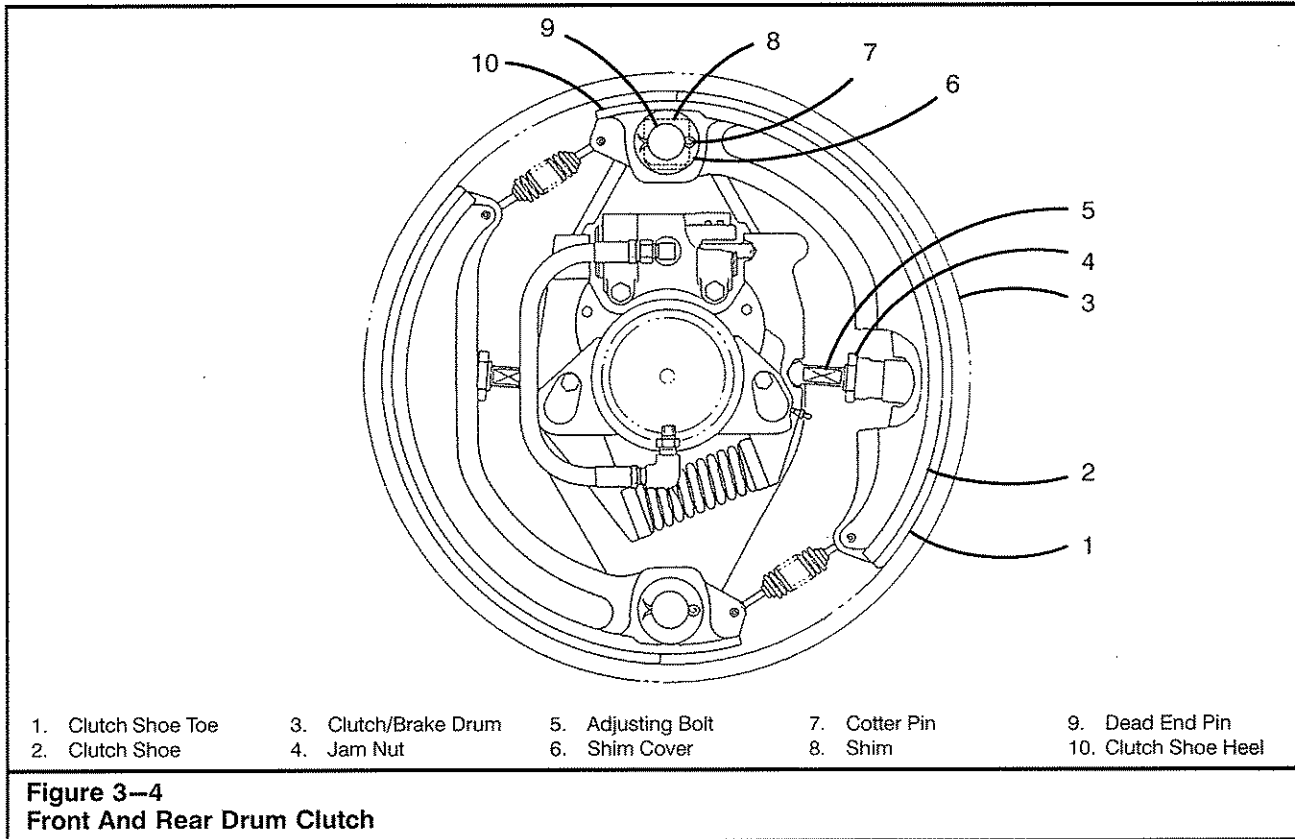

Winch Drum Clutches

The front and rear winch systems use clutches to transfer torque from the drum shafts to the winch drum. These clutches are hydraulically applied and spring released. To compensate for lining wear, the clutches will require periodic adjustment. The clutches should have .014 – .026 in (.35 – .65mm) clearance from the heel to the toe of each clutch shoe, with the clutches released. Inspect the clutch linings for wear damage or oil contamination and check the adjustment when a new crane is delivered and every 50 hours of operation thereafter.



WARNING

Clutch Lining Fiber Warning

Older clutch linings may contain asbestos fibers, a cancer and lung disease hazard. Clutch linings manufactured today contain non-asbestos fibers, whose long-term effects to health are unknown. Use caution when handling either asbestos or non-asbestos materials used in clutch linings. Refer to OSHA regulations for proper handling of these materials. Material Safety Data Sheets (MSDS) regarding clutch lining materials can be obtained from your Link-Belt Distributor.

Operator's Manual

Drum Clutch Adjustment



WARNING

Extreme care should be exercised to ensure proper adjustment of the clutch. An improperly adjusted clutch can cause hoisting power to be reduced and a load lowered by lowering clutch to fall.

1. Park the crane on a firm, level surface. Position the upper directly over the front or rear of the lower and engage the travel swing lock.
2. Lower the hook block and hook ball to the ground to prevent them from falling during the brake adjustment. Shutdown the engine.
3. Remove the winch drum cover from the left end of the winch drum to expose the brake and clutch.
4. Loosen the adjusting bolt jam nut and turn the adjusting bolt until the toe of the clutch shoe just contacts the clutch/brake drum. Refer to Figure 3-4.
5. Remove the cotter pin and shim cover from the dead end pin.
6. Add shims, as required, between the dead end pin and clutch shoe until the heel of the clutch shoe is within 0.014–0.026 in (0.35–0.65mm) of the clutch/brake drum.

Note: The 0.014–.026 in (0.35–0.65mm) clearance must be achieved along the entire length of the clutch shoe. Add or remove shims, as required, while turning the adjusting bolt to obtain the proper clearance.

7. Turn the adjusting bolt until the 0.014–0.026 in (0.35–0.65mm) clearance is obtained between the toe of the clutch shoe and the clutch/brake drum.
8. Lightly oil the dead end pin and inspect the clutch linings for major wear or oil contamination. Use extreme care to avoid getting oil on the clutch shoe or clutch/brake drum.



WARNING

Use extreme care to avoid getting oil on the clutch shoe or clutch/brake drum. Oil could cause erratic clutch operation and result in an accident.

9. Replace the shim cover and cotter pin.
10. Torque jam nut to 145 ft lb (196Nm).

11. Check the adjustment by making sure the winch will lift at maximum line pull without slipping.
12. Repeat this procedure for each clutch shoe on each winch drum as equipped.
13. Install the winch drum cover.

Drum Clutch Inspection



WARNING

Clutch Lining Fiber Warning

Older clutch linings may contain asbestos fibers, a cancer and lung disease hazard. Clutch linings manufactured today contain non-asbestos fibers, whose long-term effects to health are unknown. Use caution when handling either asbestos or non-asbestos materials used in clutch linings. Refer to OSHA regulations for proper handling of these materials. Material Safety Data Sheets (MSDS) regarding clutch lining materials can be obtained from your Link-Belt Distributor.

To ensure safe, troublefree operation of the drum clutches, periodic inspections must be made. An inspection should be done each 50 hours of operation or monthly whichever occurs first. Use the following instructions for inspecting the drum clutches. All procedures must be carried out by a qualified technician and detailed records of the work performed must comply with OSHA record keeping practices.

1. Park crane on a firm, level surface.
2. Apply all brakes and/or drum pawls to secure movement of drums or lower hook block, hook ball, or bucket to the ground. Engage the travel swing lock and shutdown the engine.
3. Remove the drum covers and/or guards to gain access to all drum clutches.
4. Inspect for any oil, grease, abrasive particles, or rust on the friction surface of the clutch drum or on the clutch linings.
5. Inspect all actuating linkage, related pins, and bolts for excessive wear and proper lubrication.
6. Inspect the drum clutches for indications of any bending, cracking, interference, or unusual wear of the clutch linings.
7. Replace any defective parts, as required, for any of the above reasons.
8. Properly adjust the clutches as outlined in this Section of this Operator's Manual.
9. Install the drum covers and/or guards.

Operator's Manual

10. Don't pull sideways on the boom or jib. Lift straight up on every load. Moving trucks, rail cars, barges, or anything else pulling sideways on the winch wire rope could buckle the boom or jib. It could also damage the swing mechanism. Pulling sideways on a boom or jib can overturn the crane.
11. Do not "two block" (pulling the hook block, hook ball, or load into the head machinery) as this can cause winch wire rope breakage, sheave damage, or could pull the boom backwards over the crane resulting in an accident.
12. Ensure the boom hoist pawl is engaged except when lowering the boom. Don't rely on the boom hoist brake alone to hold the boom. Wear, improper adjustment, water or oil on linings, and many other factors may affect the ability of the brake to hold the boom.
13. Watch the load or a signal person at all times. A suspended load must have your undivided attention.
14. Operate the crane from the operator's seat only. Operating the crane from any other position, such as reaching in a window, constitutes a safety hazard.
15. After slack winch wire rope operation, ensure the winch wire rope is properly seated in sheaves and on drums before continuing to operate. Use a stick or mallet to set the winch wire rope, not your hands.
16. Do not lower the load beyond the point where less than three full wraps of winch wire rope are left on the drum. This condition could occur when lowering a load beyond ground level. If all the winch wire rope runs off the drum, the load will jerk which could break the winch wire rope.

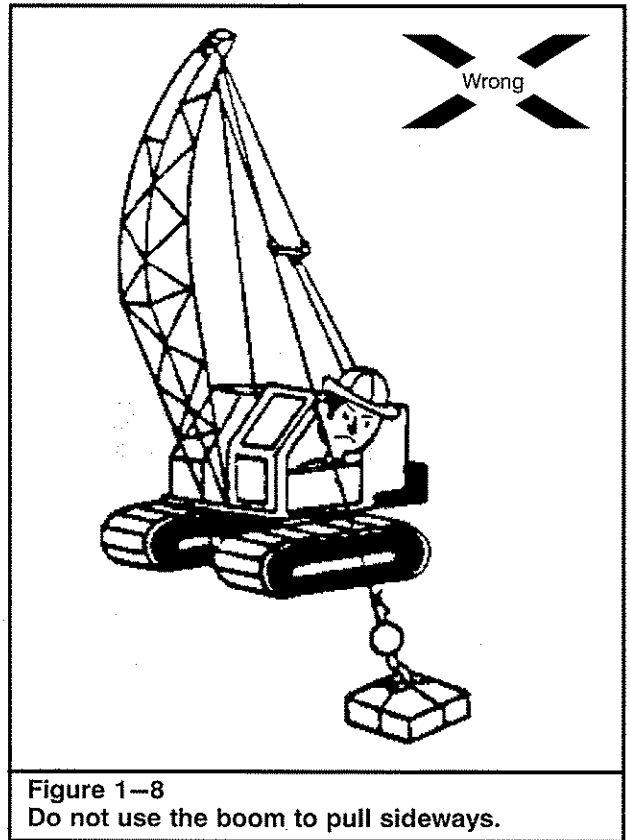
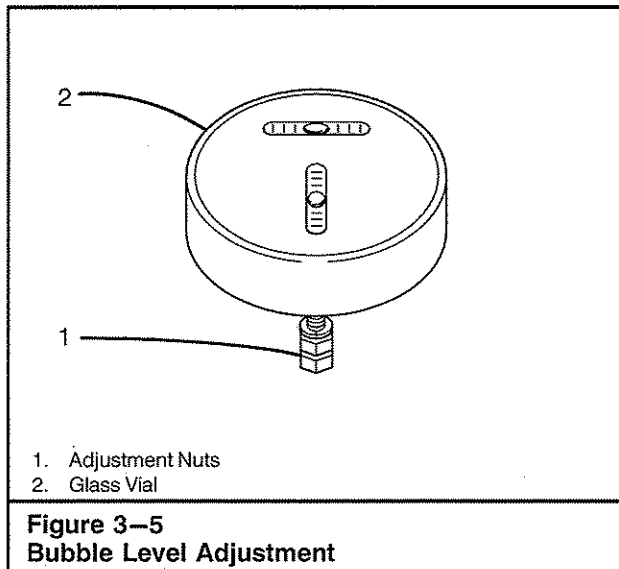

Figure 1--8
Do not use the boom to pull sideways.

17. Confirm that there is a safety latch on the hook, and that it works properly. Without a latch, it is possible for slings or chains to come off the hook, allowing the load to fall.

Operator's Manual



Bubble Level

A bubble level is mounted in the operator's cab to ensure that the crane is level before operating. It should be checked periodically to ensure proper adjustment.

Bubble Level Adjustment

1. Park the crane on a firm, level surface. Position the upper directly over the front or rear of the lower, engage the travel swing lock, and shutdown the engine.
2. Verify the crane is level by placing a carpenter's level on the lower frame. Check levelness front to back and side to side.
3. Rotate the adjustment nuts, as required, until the bubble inside each of the glass vials is centered within the vial. Both bubbles must be centered simultaneously. Refer to Figure 3-5.

Note: Do not flatten out the springs under the bubble level. Loosen, rather than overtighten, the adjustment nuts to gain the necessary adjustment.

Crane Monitoring System

The Load Moment Indicator (LMI) System must be inspected as outlined in Section 2 of this Operator's Manual or at anytime there is an indication of inaccuracy. The LMI System is calibrated and configured by the operator. Refer to Section 1 of this Operator's Manual for LMI System operation.

Hydraulic System Relief Valve Adjustment

The following instructions pertain to checking and adjusting relief valve pressures in the hydraulic system.

CAUTION

Relief valves are provided to protect the hydraulic system. Do not increase relief valve pressures above specifications or hydraulic system damage may occur.

Preparing the Crane For Checking Relief Pressures

1. Park the crane on a firm level surface. Position the upper directly over the front or rear of the lower, engage the travel swing lock, and shutdown the engine.

Note: Checking relief valve pressures is simplified by using two persons, one to operate the controls and one to check and adjust the relief valves.

Relief Valve Pressure Checking Instructions

Refer To Chart "A" and Figure 3-6 thru Figure 3-10 for relief valve and quick disconnect fitting locations.

1. Use a gauge of known accuracy. Have the gauge calibrated if necessary.

2. Work the control for the circuit being checked back and forth to relieve any trapped hydraulic pressure.

Note: For functions which are operated by a toggle switch, the ignition switch must be in the "ON" position but do not start the engine.



WARNING

All trapped hydraulic pressure must be exhausted from the system before installing a gauge in any quick disconnect. A sudden release of hot oil could cause serious burns or other serious injury.

3. Install the pressure gauge in the specified hydraulic line.
4. Refer to the "Hydraulic Pressure Settings" Charts to determine the correct pressure setting for the circuit being checked. Also, review the procedure for checking that particular circuit.
5. Start the engine.
6. If applicable, fully engage the control for the circuit being checked and hold it in that position.
7. With the engine running at the speed specified in the procedure, check the gauge for the correct reading and adjust as required.

Note: If adjustment of the relief valve is required, start the adjustment with the gauge reading below the prescribed value. Make the final adjustment by bringing the pressure setting up to the final value.

8. Allow the engine to return to idle before shutting it down.
9. Work the control back and forth to relieve any hydraulic pressure before removing pressure gauge from hydraulic line.

Operator's Manual

Hydraulic Pressure Settings Chart

Relief Valve	Hydraulic Circuit	Adjustment Location	Relief Setting
1	Travel	Refer to Figure 3-6	4,270 psi (300kgf/cm ²)
2	Boom Hoist	Refer to Figure 3-6	3,410 psi (240kgf/cm ²)
3	Front, Rear, & Third Drum	Refer to Figure 3-7	3,980 psi (280kgf/cm ²)
4	Swing Side Frame Extend/Retract	Refer to Figure 3-8	2,990 psi (210kgf/cm ²)
5	Counterweight Removal	Refer to Figure 3-9	2,990 psi (210kgf/cm ²)
6	Pilot Control	Refer to Figure 3-10	1,140 psi (80kgf/cm ²)

Chart A
Relief Valve Pressures And Adjustment Locations

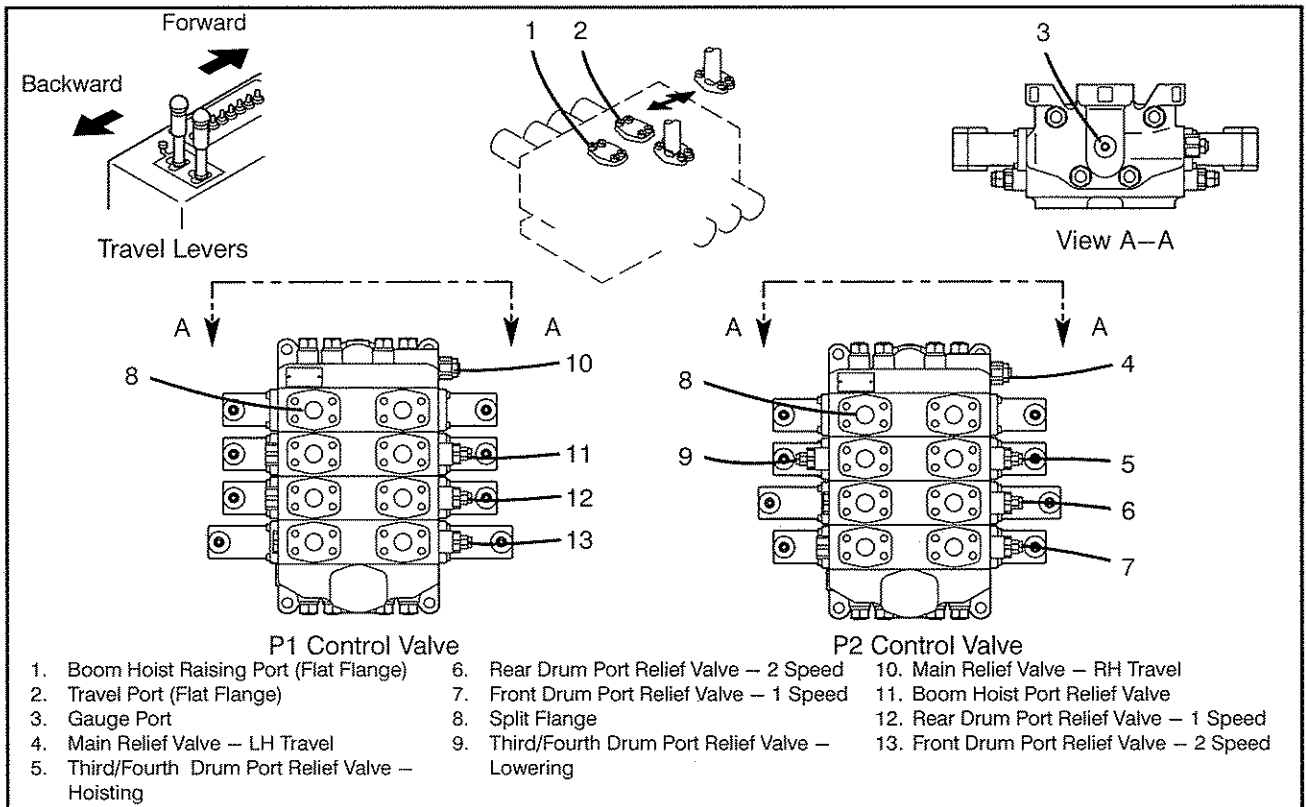

Figure 3-6
Travel And Boom Hoist Hydraulic Pressure Setting

Travel Circuit Adjusting Procedure

1. Review all the general instructions given in this Section of this Operator's Manual per "Relief Valve Pressure Checking Instructions".
2. Shutdown the engine.
3. Move the travel control levers back and forth several times to release any residual pressure from the hydraulic lines.
4. Install a pressure gauge in the gauge port on the P1 control valve. Refer to Figure 3-6.
5. Remove the right travel split flange from the control valve. Install a flat flange over right travel port. Cap hydraulic hose to prevent contaminants from entering system.
6. Start the engine and engage the right travel control lever.
7. Gradually increase the engine speed to 2,200 rpm.
8. Adjust the main relief valve pressure to 4,270 psi (300kgf/cm²).
9. Shutdown the engine.
10. Move the travel control levers back and forth several times to release any residual pressure from the hydraulic lines.
11. Remove the pressure gauge from the gauge port.
12. Repeat procedure for the P2 control valve.

Boom Hoist Circuit Adjusting Procedure

1. Review all the general instructions given in this Section of this Operator's manual per "Relief Valve Pressure Checking Instructions".
2. Shutdown the engine.
3. Move the boom hoist control lever back and forth several times to release any residual pressure from the hydraulic lines.
4. Install a pressure gauge in the gauge port on the P1 control valve. Refer to Figure 3-6.
5. Remove the boom hoist hoisting split flange from the control valve. Install a flat flange over boom hoist hoisting port. Cap hydraulic hose to prevent contaminants from entering system.
6. Start the engine and engage the boom hoist control lever in the hoist position.
7. Gradually increase the engine speed to 2,200 rpm.
8. Adjust the port relief valve pressure to 3,410 psi (240kgf/cm²).
9. Shutdown the engine.
10. Move the boom hoist lever back and forth several times to release any residual pressure from the hydraulic lines.
11. Remove the pressure gauge from the gauge port.

Operator's Manual

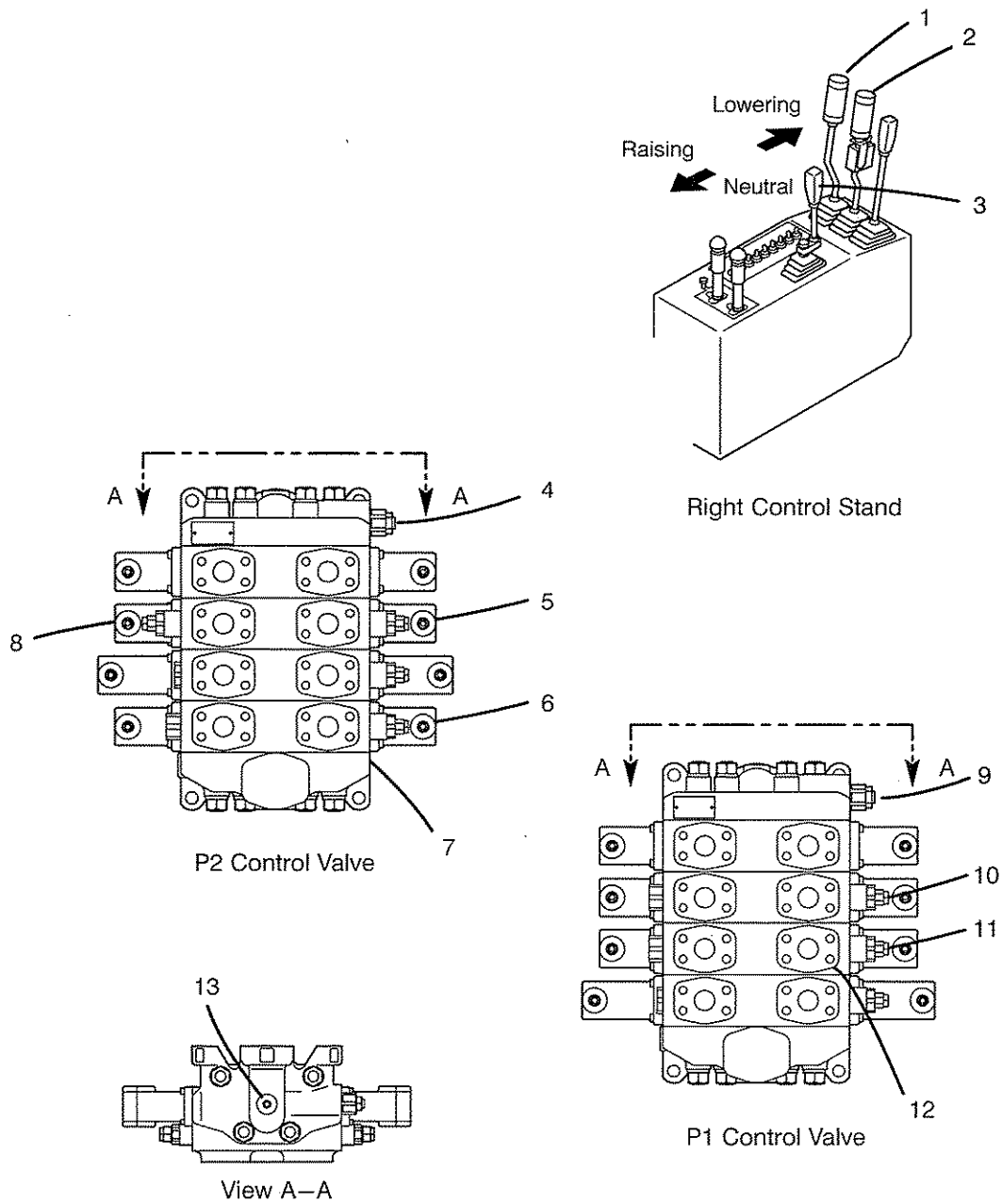

- | | | |
|---|---|----------------------------------|
| 1. Front Drum Control Lever | 6. Front Drum Port Relief Valve | 10. Boom Hoist Port Relief Valve |
| 2. Left Drum Control Lever | 7. Front Drum Hoist Split Flange | 11. Rear Drum Port Relief Valve |
| 3. Third/Fourth Drum Control Lever | 8. Third/Fourth Drum Port Relief Valve – Lowering | 12. Rear Drum Hoist Split Flange |
| 4. Main Relief Valve – LH Travel | 9. Main Relief Valve – RH Travel | 13. Gauge Port |
| 5. Third/Fourth Drum Port Relief Valve – Hoisting | | |

Figure 3–7
Winch Drum Hydraulic Pressure Setting

Front, Rear, Third, And Fourth Drum Circuit Adjusting Procedure

Front Drum

1. Review all the general instructions given in this Section of this Operator's Manual per "Relief Valve Pressure Checking Instructions".
2. Shutdown the engine.
3. Move the front drum control lever back and forth several times to release any residual pressure from the hydraulic lines.
4. Install a pressure gauge in the gauge port on the P2 control valve. Refer to Figure 3-7.
5. Remove the front drum hoisting split flange (7) from the P2 control valve. Install a flat flange over front drum hoisting port. Cap hydraulic hose to prevent contaminates from entering system.
6. Start the engine and engage the front drum lock switch.
7. Move the front drum control lever to the hoist position.
8. Gradually increase the engine speed to 2,000 rpm.
9. Adjust front drum port relief valve (6) hoisting pressure to 3,980 psi (280kgf/cm^2).
10. Shutdown the engine.
11. Move the front drum control lever back and forth several times to release any residual pressure from the hydraulic lines.
12. Remove the pressure gauge from the gauge port.

Rear Drum

1. Review all the general instructions given in this Section of this Operator's Manual per "Relief Valve Pressure Checking Instructions".
2. Shutdown the engine.
3. Move the rear drum control lever back and forth several times to release any residual pressure from the hydraulic lines.
4. Install a pressure gauge in the gauge port on the P1 control valve. Refer to Figure 3-7.
5. Remove the rear drum hoisting split flange (12) from the P1 control valve. Install a flat flange over

- rear drum hoisting port. Cap hydraulic hose to prevent contaminates from entering system.
6. Start the engine and engage the rear drum lock switch.
7. Move the rear drum control lever to the hoist position.
8. Gradually increase the engine speed to 2,000 rpm.
9. Adjust rear drum port relief valve (11) hoisting pressure to 3,980 psi (280kgf/cm^2).
10. Shutdown the engine.
11. Move the rear drum control lever back and forth several times to release any residual pressure from the hydraulic lines.
12. Remove the pressure gauge from the gauge port.

Third/Fourth Drum

1. Review all the general instructions given in this Section of this Operator's Manual per "Relief Valve Pressure Checking Instructions".
2. Shutdown the engine.
3. Move the third/fourth control lever back and forth several times to release any residual pressure from the hydraulic lines.
4. Install a pressure gauge in the gauge port on the P2 control valve. Refer to Figure 3-7.
5. Remove the third/fourth drum hoisting split flange from the control valve. Install a flat flange over third/fourth drum hoisting port. Cap hydraulic hose to prevent contaminates from entering system.
6. Start the engine and engage the third/fourth control lever in the hoist position.
7. Gradually increase the engine speed to 2,200 rpm.
8. Adjust the port relief valve pressure to 3,980 psi (280kgf/cm^2).
9. Shutdown the engine.
10. Move the boom hoist lever back and forth several times to release any residual pressure from the hydraulic lines.
11. Remove the pressure gauge from the gauge port.
12. Repeat procedure for the third/fourth drum lowering side.

Operator's Manual

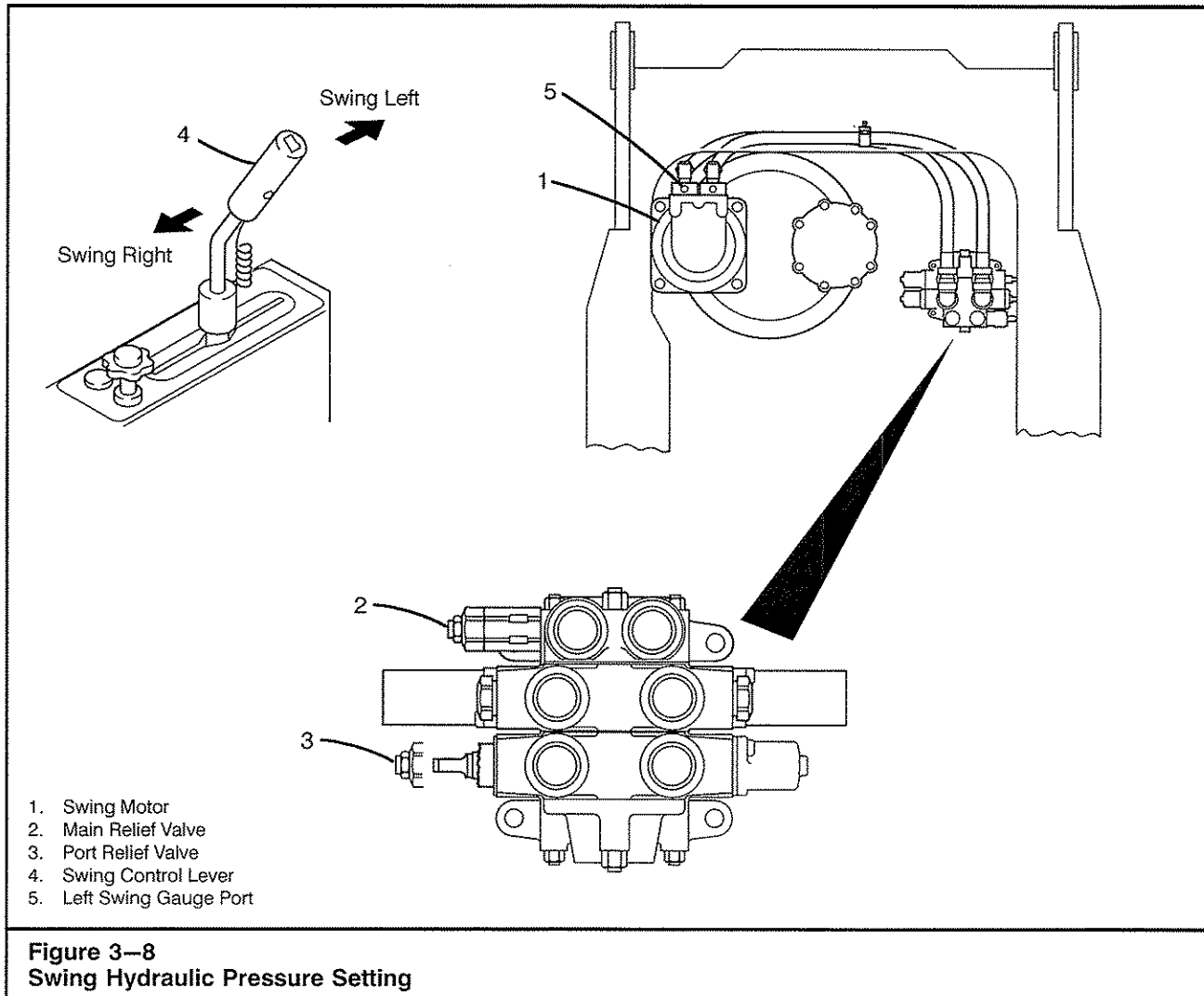

Swing/Side Frame Extend/Retract Circuit Adjusting Procedure

1. Review all the general instructions given in this Section of this Operator's Manual per "Relief Valve Pressure Checking Instructions".
2. Shutdown the engine.
3. Move the swing control lever back and forth several times to release any residual pressure from the hydraulic lines.
4. Install a pressure gauge in the left swing gauge port.
5. Start the engine and engage the swing (park) brake switch (swing brake indicator light will illuminate) and travel swing lock.
6. Move the swing control lever into the swing left position.
7. Gradually increase the engine speed to 2,200 rpm.
8. Adjust main relief to 2,990 psi (210kgf/cm²).
9. Fully retract side frames
10. Shutdown the engine and engage all drum locks.
11. Move the swing control lever back and forth several times to release any residual pressure from the hydraulic lines.
12. Remove pressure gauge from the left swing gauge port.
13. Disconnect hydraulic line for side frame extend/retract cylinder. Install a pressure gauge in the hydraulic line.
14. Start the engine and gradually increase the engine speed to 2,200 rpm.
15. Adjust port relief to 2,990 psi (210kgf/cm²).
16. Shutdown the engine.
17. Move the side frame extend/retract control lever back and forth several times to release any residual pressure from the hydraulic lines.
18. Remove the pressure gauge from the hydraulic line and connect the line to its original location.

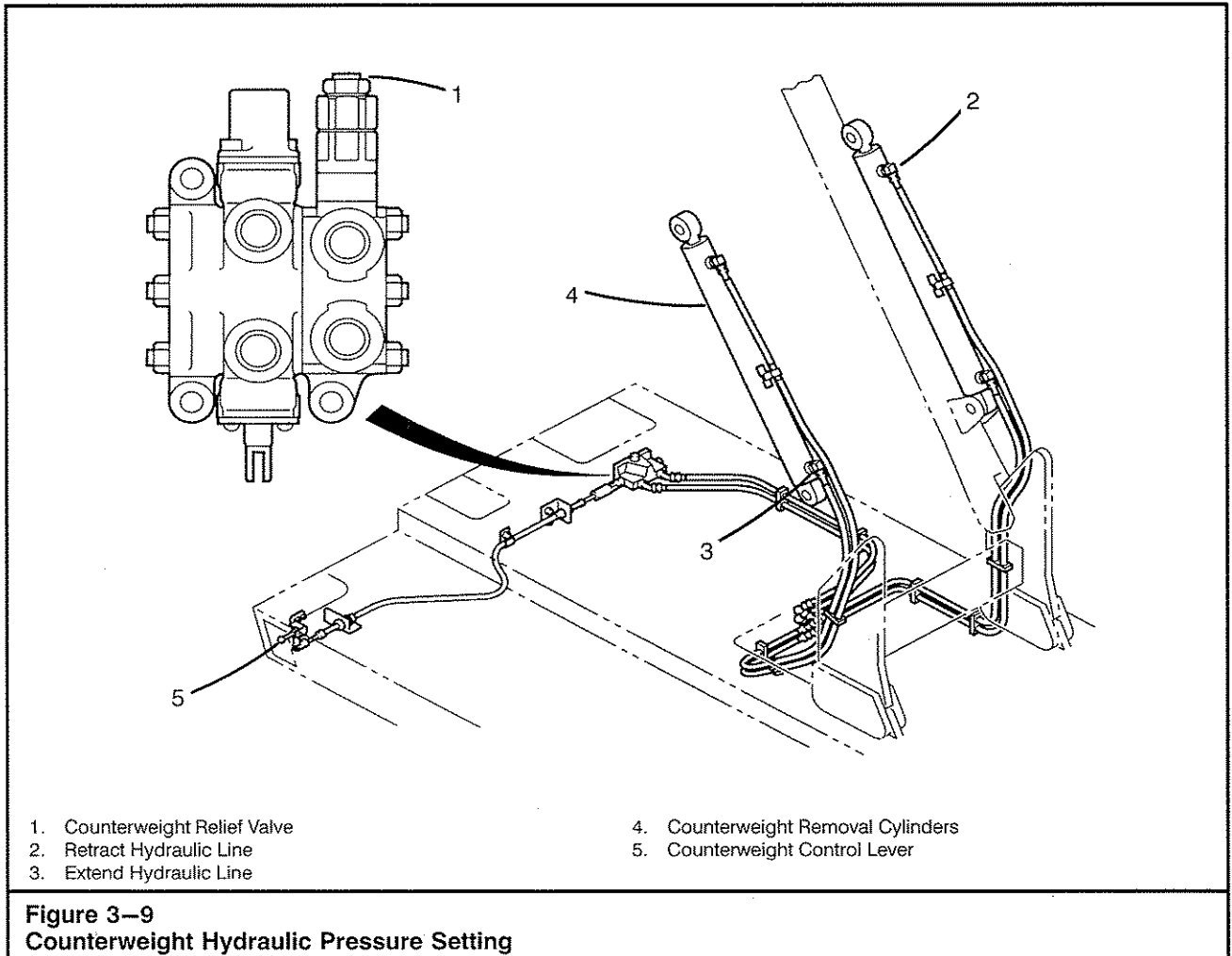

Counterweight Circuit Adjusting Procedure

1. Review all the general instructions given in this Section of this Operator's Manual per "Relief Valve Pressure Checking Instructions".
2. Shutdown the engine.
3. Engage all drum locks.
4. Move the counterweight removal control lever back and forth several times to release any residual pressure from the hydraulic lines.
5. Install a pressure gauge in one of the counterweight cylinder retract hydraulic lines.
6. Start the engine.
7. Gradually increase the engine speed to 2,200 rpm.
8. Move the counterweight control lever to the "RETRACT" position.
9. Adjust the relief pressure to 2,990 psi (210kg/cm²).
10. Shutdown the engine.
11. Move the counterweight removal control lever back and forth several times to release any residual pressure from the hydraulic lines.
12. Remove the pressure gauge from the hydraulic line and connect the line to its original location.

Operator's Manual

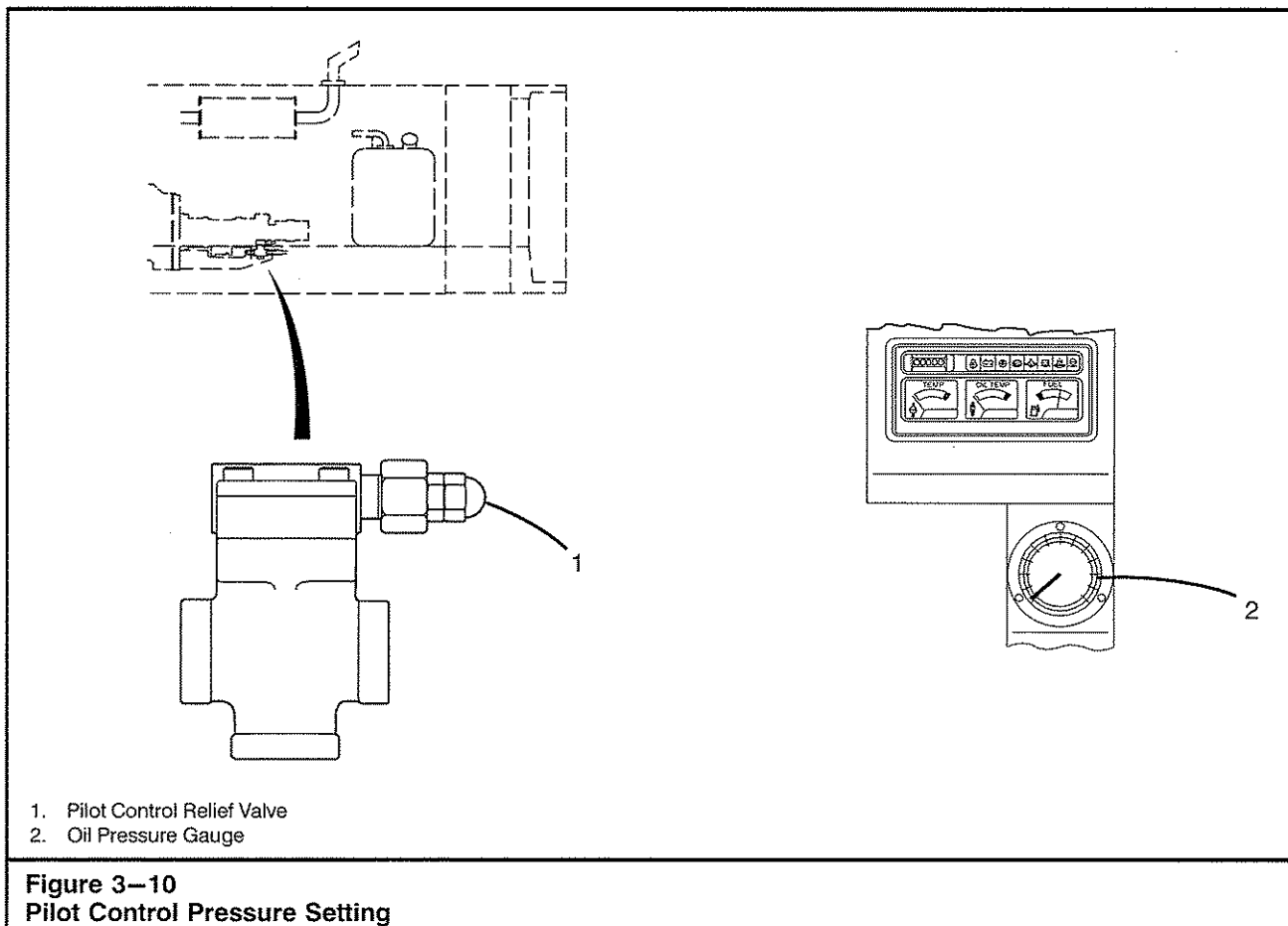

Pilot Control Adjusting Procedure

1. Review all the general instructions given in this Section of this Operator's Manual per "Relief Valve Pressure Checking Instructions".

Note: Idle speed must be maintained in order to obtain an accurate reading.

2. Start the engine and maintain idle speed.

Note: Ensure that the counterweight removal control lever is in the neutral position. If the lever is in the extend or retract position, the pressurized oil will not flow to the relief valve.

3. While reading the pressure on the oil pressure gauge, adjust the relief pressure to 1,140 psi (80kgf/cm²).

Operator's Manual

Table Of Contents

Boom Backstops	4-1
Base Section Lifting Device	4-2
Open Throat Angle Boom Assembly And Disassembly	4-3
Lifting Capacity	4-4
Maximum Rated Capacity	4-4
Main Pendants And Links	4-4
Basic Pendants	4-4
Pendants (General)	4-4
Recommended Boom Make-Up Chart	4-5
Pendant Length Requirements	4-5
Deflector Rollers	4-6
Boom Inspection	4-6
Boom Label Inspection	4-6
Double Tapered Pin Installation	4-7
Double Tapered Pin Removal	4-7
Safety Instructions	4-8
Boom Base Section Installation	4-11
Boom Base Section Removal	4-12
Boom Assembly	4-14
Boom Hoist Limit Switch Adjustment	4-16
Boom Disassembly	4-17
Boom Folding/Unfolding System	4-18
Boom Folding System	4-18
Boom Unfolding System	4-18
Auxiliary Tip Extension	4-21
Tubular Jib Assembly And Disassembly	4-22
Safety Instructions	4-23
Jib Capacity	4-23
Jib Frontstay Pendants	4-23
Jib Strut	4-23
Jib Backstay Pendant	4-23
Changing Jib Angle	4-23
Tubular Jib Assembly And Installation	4-23
Changing Jib Length	4-24
Tubular Jib Disassembly	4-24

Operator's Manual

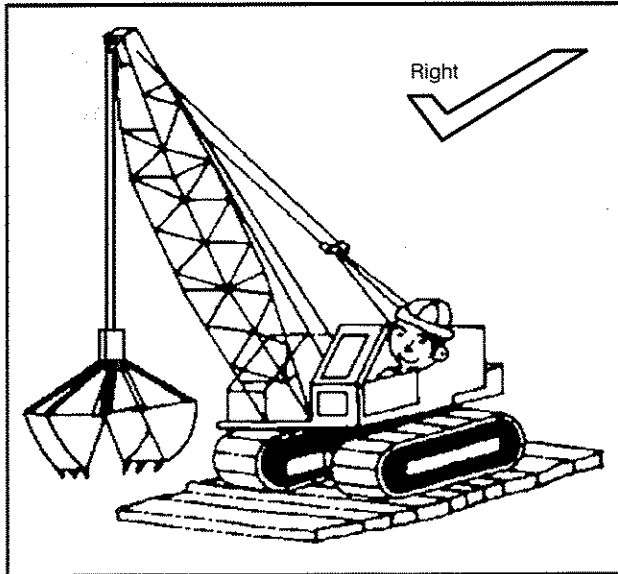
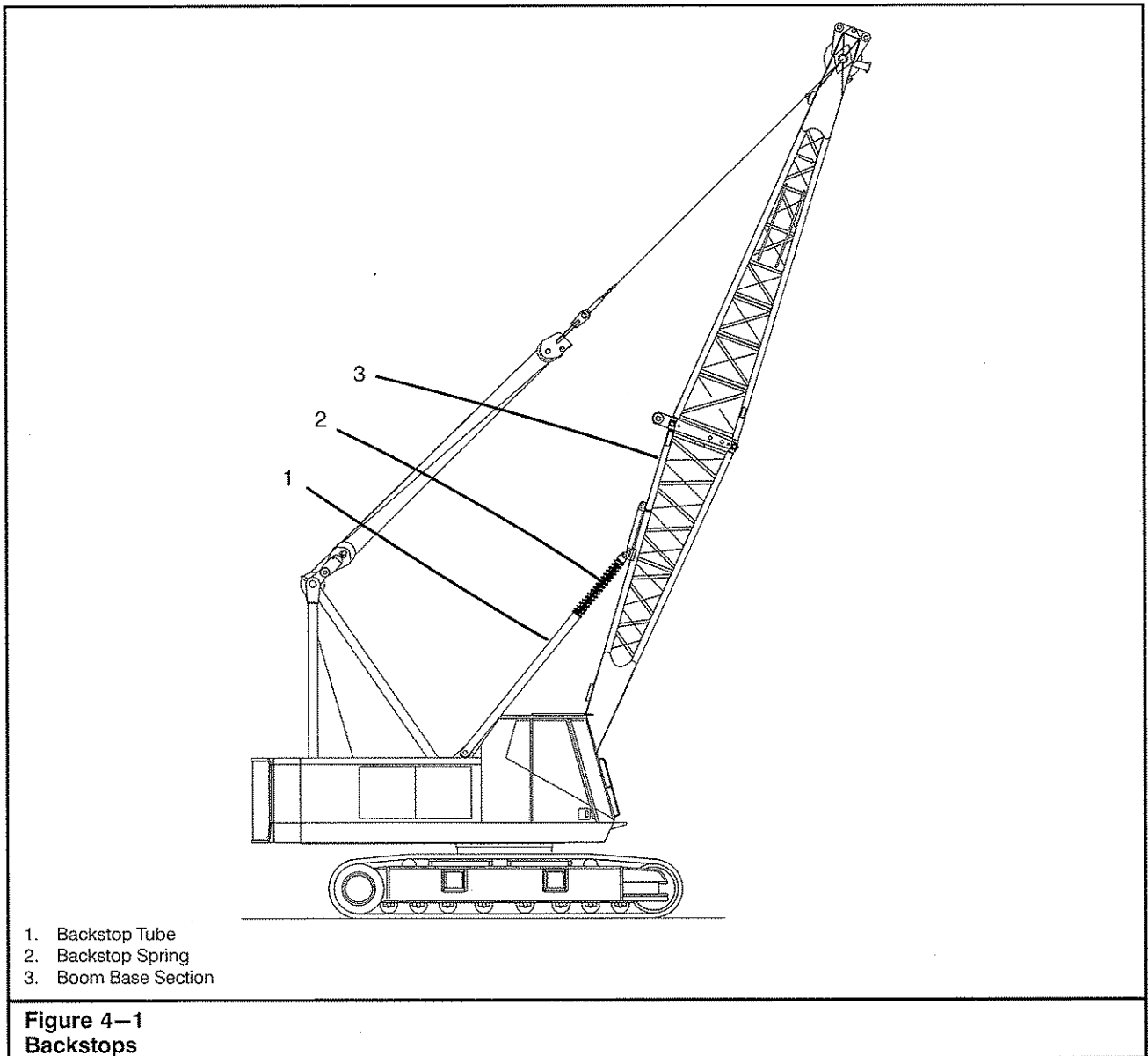

Figure 1-9
Use matting on soft ground.

18. Don't alter any part of the crane. Additions to, or changes in, any part of the equipment can create loadings for which the crane was not designed. Such changes may have a major affect on the usable capacities and make the entire Crane Rating Manual invalid. Such changes can cause major overload or weaken critical parts and may cause major failure.
19. Do not exceed the rated capacities of the crane under any circumstances. While a crane has more stability when lifting over a corner (as compared to straight over the side) the crane capacity is not increased. Any time the load exceeds the rated capacities listed in the Crane Rating Manual, the crane is overloaded. Overloads can damage the crane and such damage could cause failure and accidents.
20. Lifts where two or more cranes work together can be hazardous and should be avoided. Such lifts should be made only under the direction of a qualified engineer. If a multiple crane lift is unavoidable, observe the following rules:
 - a. The cranes must be level and setting on firm surfaces.
 - b. The cranes should be the same size and capacity, use the same boom length, and be reeved similarly.
 - c. Cranes must be positioned so that each boom point is directly over its load attaching point. The winch wire ropes must be vertical during all phases of the lift.
 - d. The rigging must be placed so each crane lifts a share of the load well within the crane's capacity.
 - e. Ensure that during handling more load is not transferred to any crane than it can handle.
 - f. Don't attempt to travel when making multiple crane lifts.
 - g. Coordinate plans with the other operator before beginning to lift.
 - h. Use only one signal person.
 - i. Use of an operable load and angle indicating system is desirable.
21. When operating the crane where the tracks sink into the soil any noticeable amount, use matting. Timbers used for matting should be at least as long as the total width of the lower and should be heavy enough to withstand loadings without damage. Timbers should be close enough to form a solid platform when lifting over lower ends (or raising and lowering attachment). Block under track ends so full support is provided where tracks leave the ground. This helps keep the tracks from digging in and cuts down on crane rocking.



Boom Backstops

This crane is equipped with mechanical type boom backstops. Refer to Figure 4-1. The backstops are connected to the upper frame and the boom. The backstops are used to limit the movement of the boom at minimum radius.

The backstops have telescoping ends that extend and retract to allow for adequate movement of the boom. When the boom approaches minimum radius, the spring loaded backstops provide a cushioning effect. When the boom begins to compress the spring, the boom hoist limit switch is activated and the boom hoist function is disabled. Refer to "Boom Hoist Limit System" in Section 1 of this Operator's Manual.

Operator's Manual

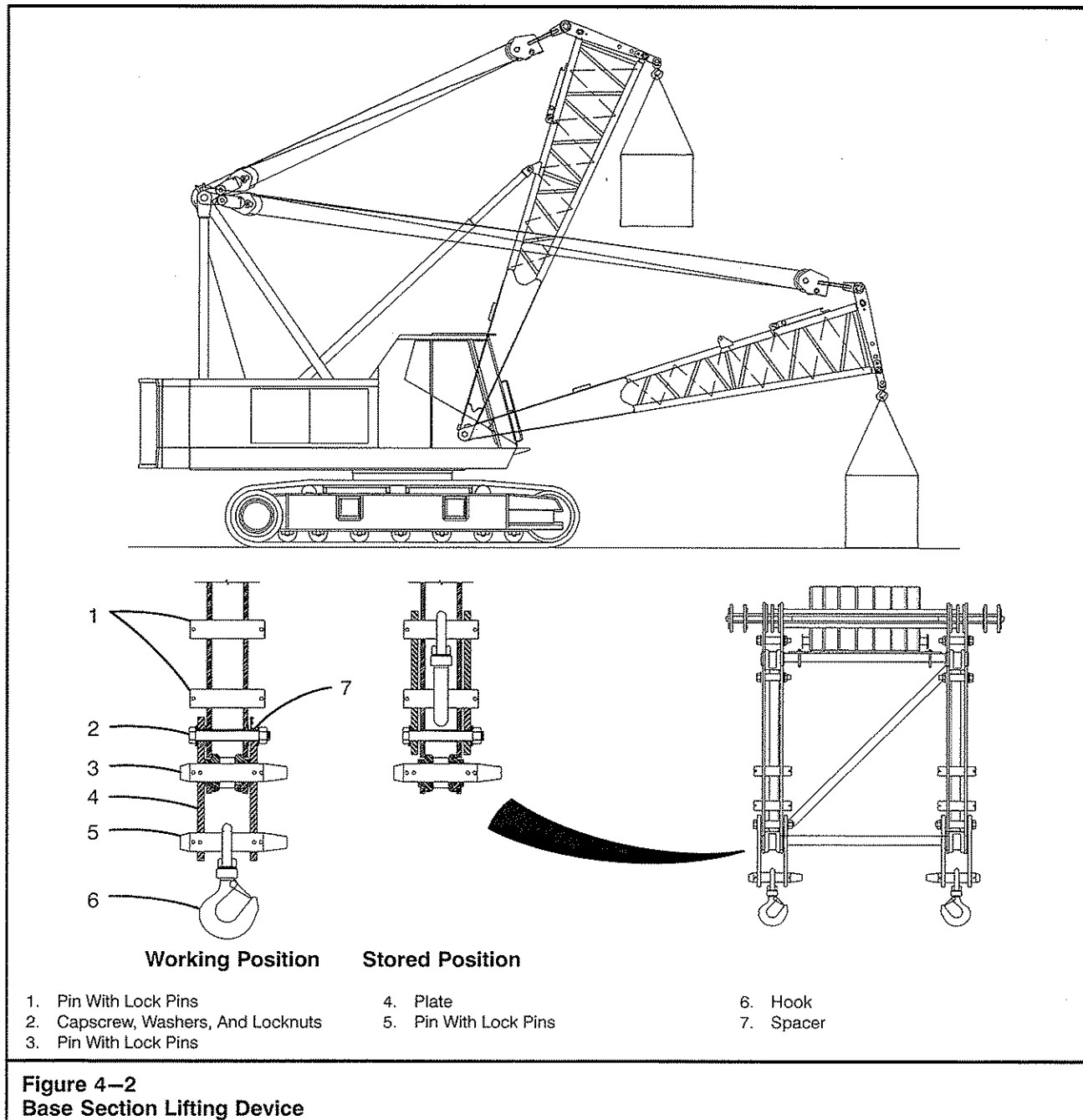

Base Section Lifting Device

The crane can be equipped with a hook installed to the handling links to assist with crane assembly. Refer to Figure 4-2. Follow all recommendations for use in the Crane Rating Manual. Use the capacities listed on the "Base Section Lifting Capacities" in the Crane Rating Manual. The lifting device must only be used for lifting boom sections, counterweights, etc. for self assembly of the crane.



WARNING

The base section lifting device is to be used to self-assemble the crane only. Lift counterweights, boom sections, etc. only. Do not use as an auxiliary lifting device for making other lifts.

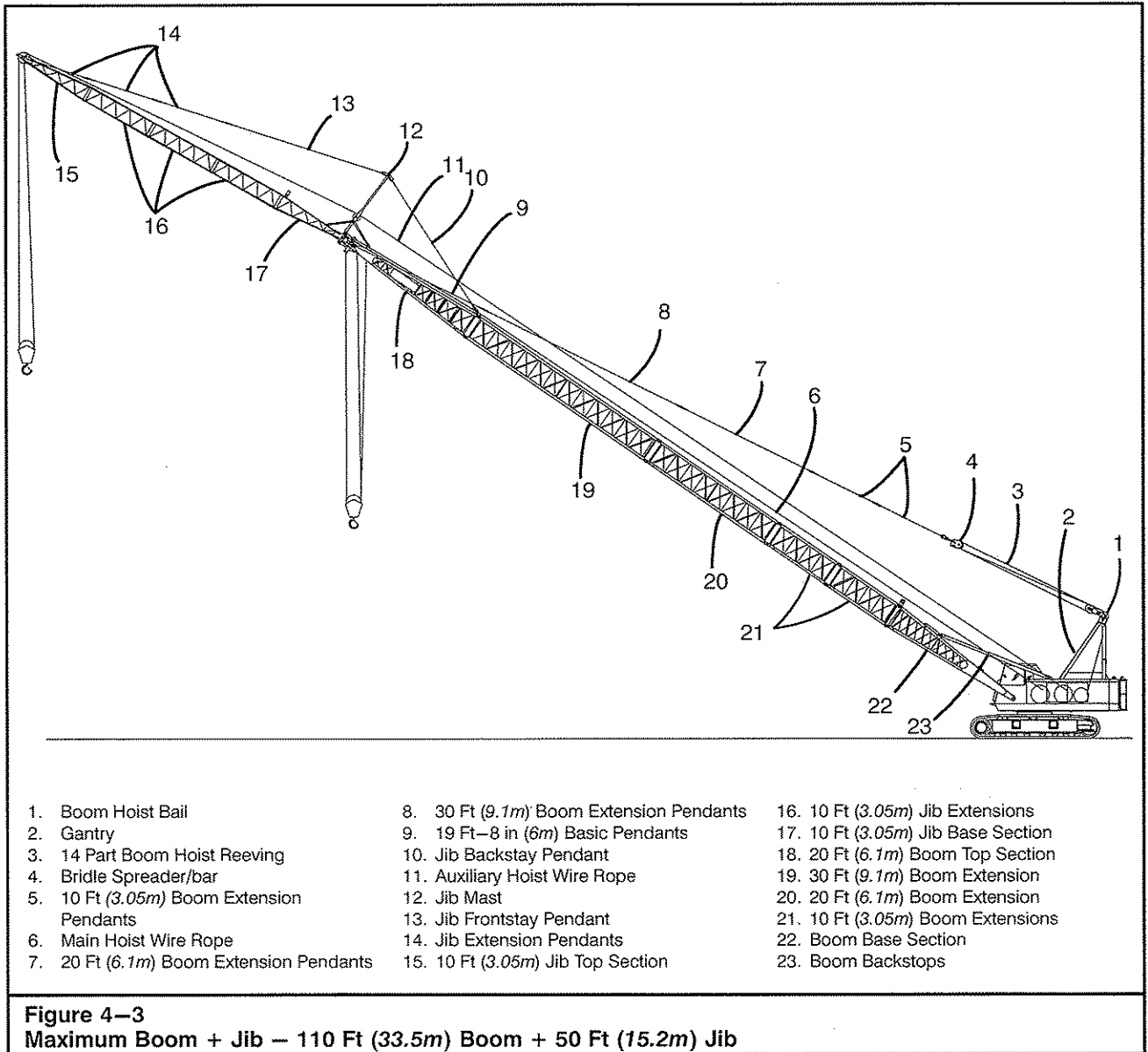

Open Throat Angle Boom Assembly And Disassembly

The following procedures outline the recommended steps necessary for safe boom base section installation and complete assembly or disassembly of the boom. Depending upon job site conditions and the availability of auxiliary equipment, these procedures can be modified using only known, proven, safe procedures to increase the efficiency of boom assembly.

Regardless of the specific method used to assemble or disassemble the boom, certain procedures must be followed to prevent reckless or inadvertent dropping of the boom. Improper assembly or disassembly of the boom can lead to serious personal injury or death. Boom section(s) could also be damaged beyond repair.

Any questions regarding safe boom assembly or disassembly procedures should be directed to your Link-Belt Distributor.

Operator's Manual

The boom can be assembled/disassembled using base section lifting device to handle all the lifting required.



DANGER

To avoid serious injury, carefully read and fully understand all boom assembly, disassembly, and safety instructions outlined in this Operator's Manual. Failure to follow these instructions could result in serious personal injury or death.

The basic boom for this crane is 40' (12.2m) in length, and consists of a 20' (6.1m) boom base section and 20' (6.1m) boom top section. The two sections are connected by four pins, in line with the boom chords. Additional boom extensions are available in 10, 20, and 30' (3.05, 6.1, and 9.1m) lengths and may be combined to form a maximum boom length of 140' (42.7m).

Lifting Capacity

The lifting capacity of a crane is based upon several factors:

- Load Radius
- Number of parts of line used to lift load
- Position of upper machinery
- Strength of materials
- Crane weight and center of gravity

Maximum Rated Capacity

Maximum rated capacity is based upon:

- Basic boom
- Minimum radius
- Eight parts of specified size and type of wire rope (front or rear drum)
- "AB" counterweight

Note: Before making any lifts, always refer to the Crane Rating Manual and stay within the rated lifting capacities.

Confirm that the load being lifted is within the rated capacity of the crane under the existing conditions. (Boom length, load radius, wire rope requirements, levelness, firmness of ground, etc.)

Main Pendants And Links

Basic Pendants

A pair of 19' 8" (6m) basic pendants are used with all boom lengths. The pair of basic pendants connect to the boom head machinery.

Pendants (General)

Additional pendants are available in 10, 20, and 30' (3.05, 6.1, and 9.1m) lengths, to match the available boom extensions.

Operator's Manual

Main Boom Length ft (m)	Boom Section Length ft (m)						
40 (12.2)	20 (6.1)	20 (6.1)					
50 (15.2)	20 (6.1)	10 (3.05)	20 (6.1)				
60 (18.3)	20 (6.1)	20 (6.1)	20 (6.1)				
70 (21.3)	20 (6.1)	30 (9.1)	20 (6.1)				
80 (24.4)	20 (6.1)	10 (3.05)	30 (9.1)	20 (6.1)			
90 (27.4)	20 (6.1)	20 (6.1)	30 (9.1)	20 (6.1)			
100 (30.5)	20 (6.1)	30 (9.1)	30 (9.1)	20 (6.1)			
110 (33.5)	20 (6.1)	10 (3.05)	30 (9.1)	30 (9.1)	20 (6.1)		
120 (36.6)	20 (6.1)	20 (6.1)	30 (9.1)	30 (9.1)	20 (6.1)		
130 (39.6)	20 (6.1)	10 (3.05)	20 (6.1)	30 (9.1)	30 (9.1)	20 (6.1)	
140 (42.7)	20 (6.1)	10 (3.05)	10 (3.05)	20 (6.1)	30 (9.1)	30 (9.1)	20 (6.1)

20 = Base And Top Section

Figure 4-4
Recommended Boom Make-Up Chart

Boom Length		Pendant Length Required	
ft	m	ft	m
40	12.2	19' 8" Basic	6 Basic
50	15.2	19' 8" + 10	6 + 3.1
60	18.3	19' 8" + 20	6 + 6.1
70	21.3	19' 8" + 30	6 + 9.1
80	24.4	19' 8" + 40	6 + 12.2
90	27.4	19' 8" + 50	6 + 15.2
100	30.5	19' 8" + 60	6 + 18.3
110	33.5	19' 8" + 70	6 + 21.3
120	36.6	19' 8" + 80	6 + 24.4
130	39.6	19' 8" + 90	6 + 27.4
140	42.7	19' 8" + 100	6 + 30.5

Figure 4-5
Pendant Length Requirements

Operator's Manual

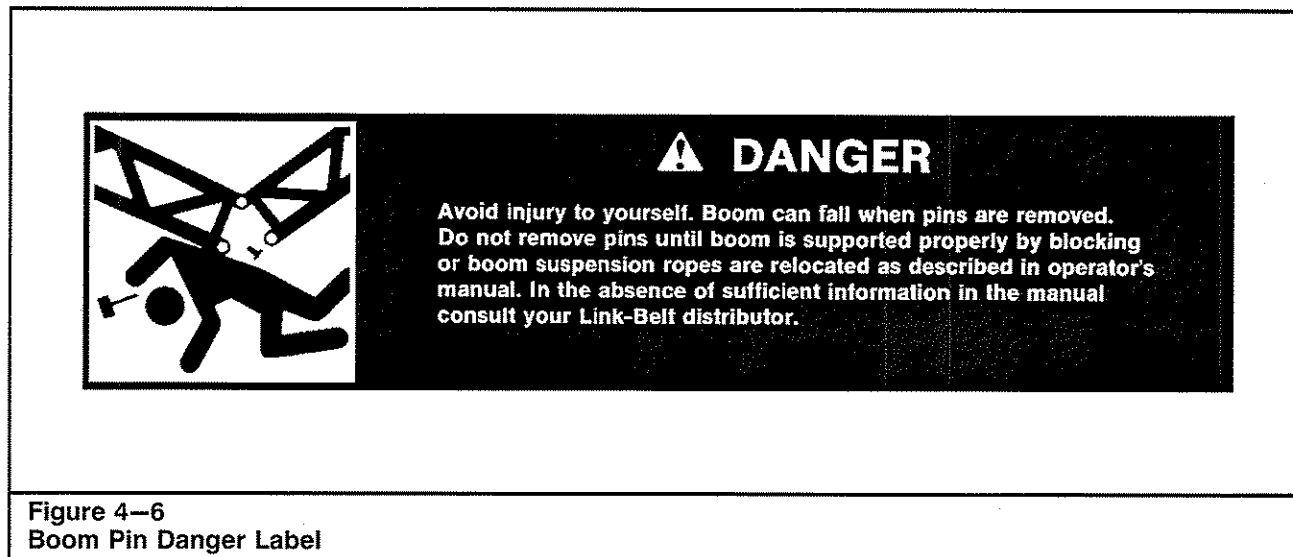

Figure 4-6
Boom Pin Danger Label

Deflector Rollers

Deflector rollers are mounted in pillow block bearings bolted to the top of the boom. They are used to guide the hoist wire rope over the top of the boom. One deflector roller must be mounted to the base end of the top section and each boom extension.

Boom Inspection

Inspect the boom periodically to ensure it has not been damaged. If a boom section has been damaged, it must be repaired or replaced before the boom is used. Damaged lattice can be replaced. Contact your Link-Belt Distributor for information on lattice replacement.

Note: If a main chord is bent or damaged, the boom section must be replaced before making any lifts.

Boom Label Inspection

Boom extensions, boom top section, and the boom base section must be equipped with boom pin removal danger labels. Refer to Figure 4-6. These danger labels are placed on all pin connected boom sections, at the factory, as a reminder of the importance of using correct procedures to remove pins from these booms.

Before starting boom assembly or after disassembly, check each boom section for warning labels. Any labels that are scratched, painted over, worn, or unreadable must be replaced. Contact your Link-Belt Distributor for replacement boom pin removal danger labels.

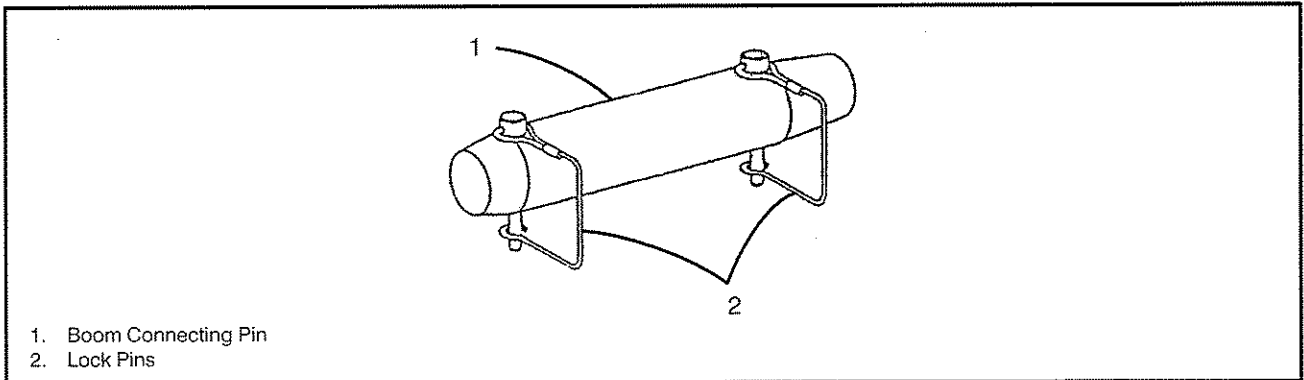

Figure 4-7
Double Tapered Boom Connecting Pins



WARNING

To avoid serious injury, carefully read and fully understand the boom assembly and disassembly instructions in this Operator's Manual. Read and fully understand these instructions before beginning boom assembly or disassembly.

Double Tapered Pin Installation

1. First read and completely understand the boom assembly instructions in this Operator's Manual.
2. Stand outside the boom connection pin lug. Do not stand inside or under the boom at anytime. See Figure 4-8.



DANGER

Do not stand or work inside or under the boom at anytime. If the boom falls, serious injury may result.

3. Drive connecting pin through the boom connection from outside to the inside of the boom. Install lock pins in both ends of boom connecting pins. See Figure 4-7.
4. Use this procedure to install all boom connecting pins required for boom assembly.

Double Tapered Pin Removal

1. First read and carefully understand the boom disassembly instructions in this Operator's Manual.
2. Stand outside the boom connecting pin lug. Do not stand inside the boom at anytime. See Figure 4-8.



DANGER

Do not stand or work inside or under the boom at anytime. If the boom falls, serious injury may result.

3. Remove both lock pins from boom connecting pin. Drive connecting pin from the outside to the inside of the boom. Remove connecting pin.
4. Use this procedure to remove all boom connecting pins specified in the boom disassembly procedure in this Operator's Manual.

Operator's Manual

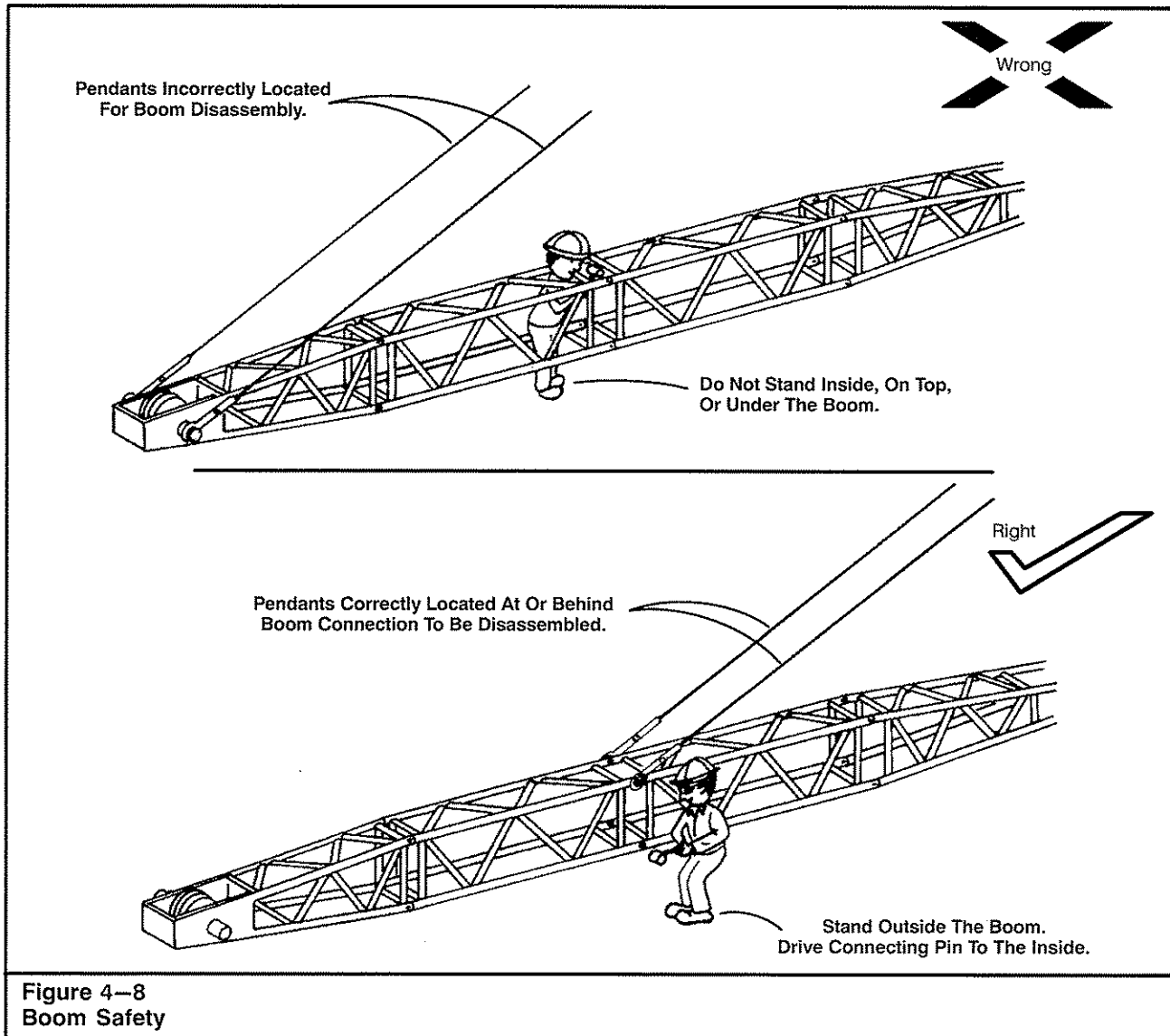

Safety Instructions

The following points must be observed while performing any boom assembly or disassembly:

1. Read and understand the instructions outlined in this Operator's Manual before attempting to assemble or disassemble the boom.
2. Do not stand inside, on top, or under the boom at anytime while assembling or disassembling the boom. Refer to Figure 4-8.
3. Do not climb, stand, or walk on the boom. Use a ladder or similar device to reach necessary areas.
4. When removing or installing the boom section connecting pins, drive the pins from the outside of the boom toward the inside.
5. Always wear proper eye protection when driving connecting pins.
6. Do not remove any connecting pins which are installed behind the boom supporting pendants. Refer to Figure 4-9.
7. Stay clear of pinch points when aligning boom section connecting lugs. Never place your fingers in connecting pin holes.
8. Use caution when disconnecting the dead end of wire ropes. Reeved wire rope can become twisted on the sheaves. When the dead end pin or socket is removed, the wire rope may spin.

Operator's Manual

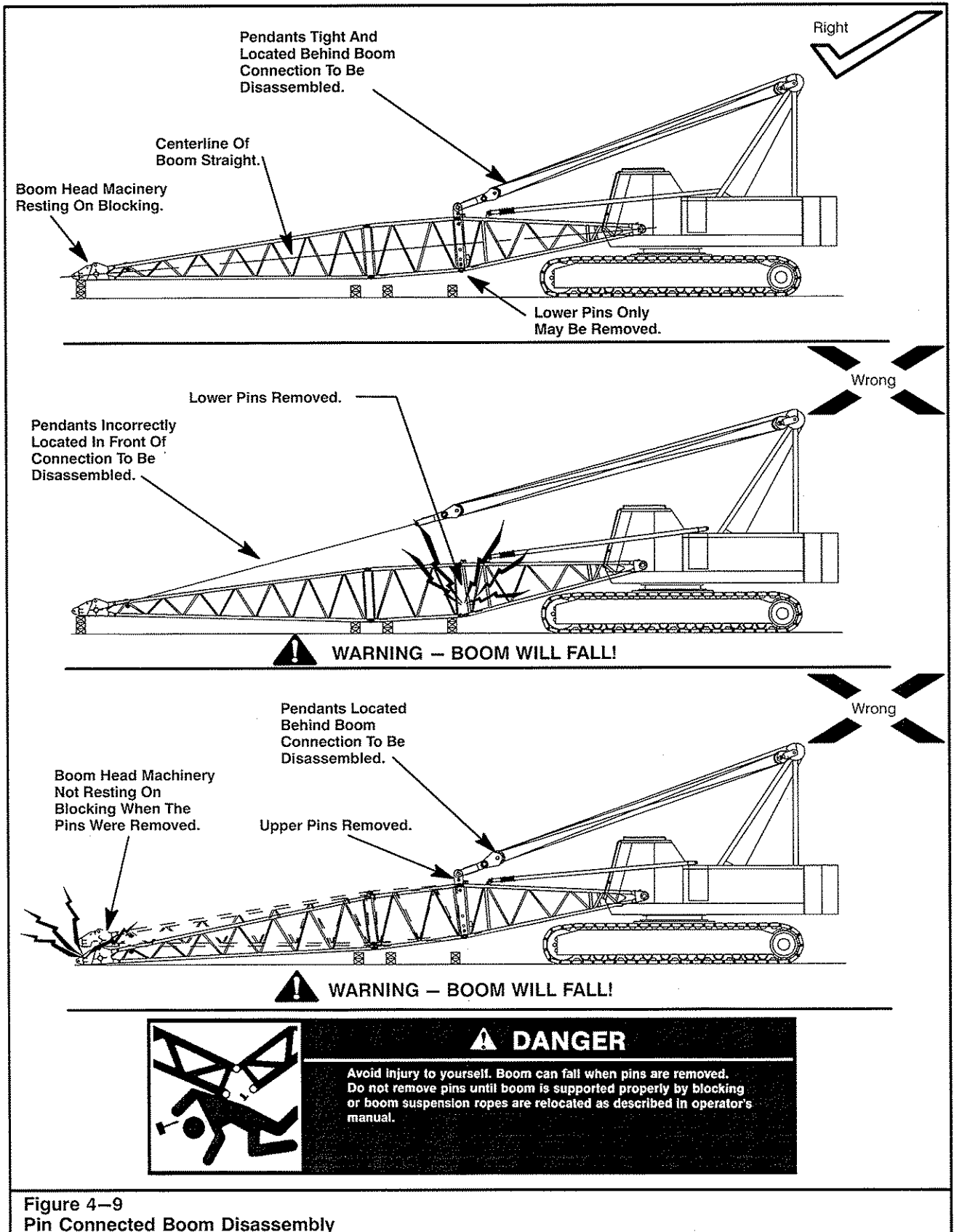

Operator's Manual

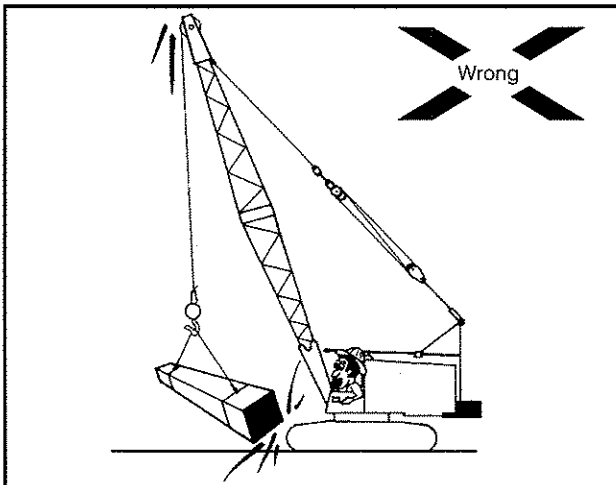

Figure 1-10
Watch that lower!

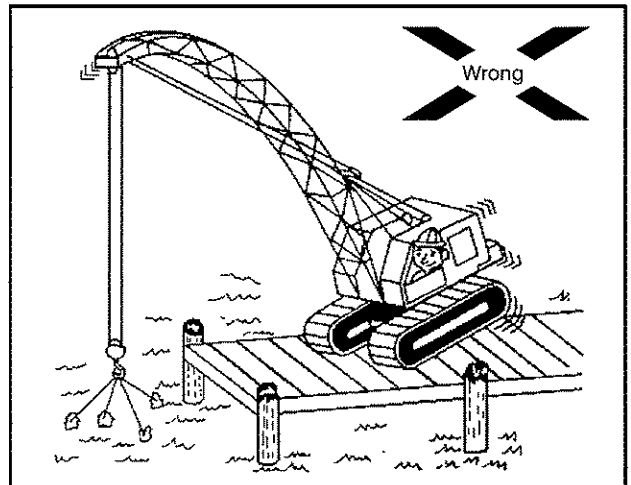

Figure 1-11
Submerged Loads

22. When operating over the front or rear, use care not to hit the lower with the load or boom.
23. When lifting submerged loads, the suction caused by the load resting on the bottom acts to increase the weight of the load; in some cases the actual load weight. This same effect can occur on land, when a load is embedded in mud. To break a load loose from suction, don't pull sideways or a boom may collapse. If possible, rig the load so it is lifted from one end. Don't jerk on the load. A steady pull, maintained for several minutes, will often free the load without over loading the equipment.

When a submerged load reaches the surface, don't attempt to lift it out of the water all at once. It may be saturated with water and will weigh many times what you expect. Allow it to drain as you raise the load slowly. Be patient, as draining may take a long time. A load when removed from the water, will have a greater effective weight than it will when submerged because of buoyancy.

24. Don't extract piling, casings, or other such loads by jerking on them. The practice of pulling on the load until the crane has tipped, then releasing the hoist line, allowing the crane to drop back and catching the hoist line on a clutch or brake may break the boom. If the piling or casing won't pull out with a smooth, steady pull, use an extractor, pulling frame, or similar rigging intended for this purpose. Pulling on a load that is not free to be lifted can develop loadings on the crane far in excess of the normal weight of the load. Imposing such loads on a crane can damage the crane and may cause disastrous failure. When using a pile extractor, use a shock or vibration insulator unit.
25. Operating with auxiliary equipment such as pile driver leads, pile hammers, or caisson boring attachments imposes additional loading in the crane. This causes a major reduction in lifting capacities of the crane. Changes in auger and Kelly bar lengths with drilling attachments and in pile hammer attachments further complicate the manner in which lifting capacities are reduced. The weight of each piece of auxiliary equipment is to be considered a part of the live load acting at the radius of the center of gravity of the piece.
26. Demolition work can be particularly hazardous. Shock loadings and side loadings from demolition ball and clamshell bucket work can be major. The repetitive nature of such work imposes heavy demands on all parts of the crane. Restrict demolition ball weights to 50% of crane capacity, with the boom length you are using, at maximum load radius. In no case however, should the ball weight exceed 50% of the available line pull.
27. When using demolition ball, avoid sudden clutch and brake applications. Work steadily and smoothly. Don't try to knock the whole structure down with one blow. Use good aim. If the ball misses its target, out swing could cause crane tipping or overload. When swinging back, ball may hit the boom and damage it.

Operator's Manual

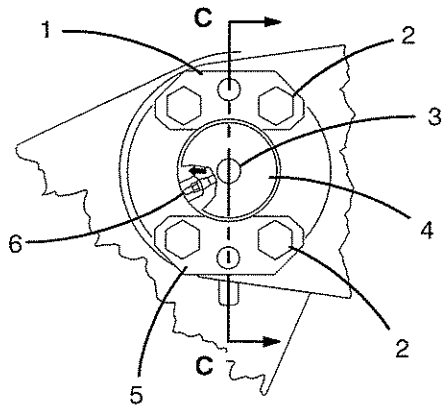

VIEW B-B
Left Side Pin

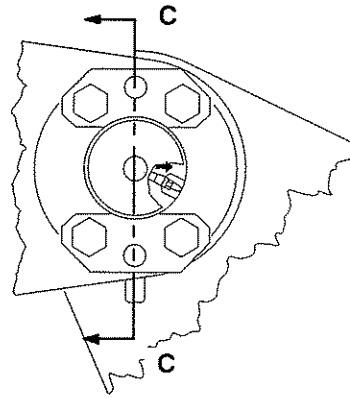

VIEW A-A
Right Side Pin

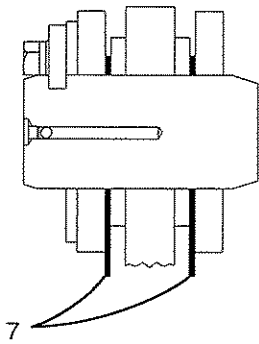

SECTION C-C

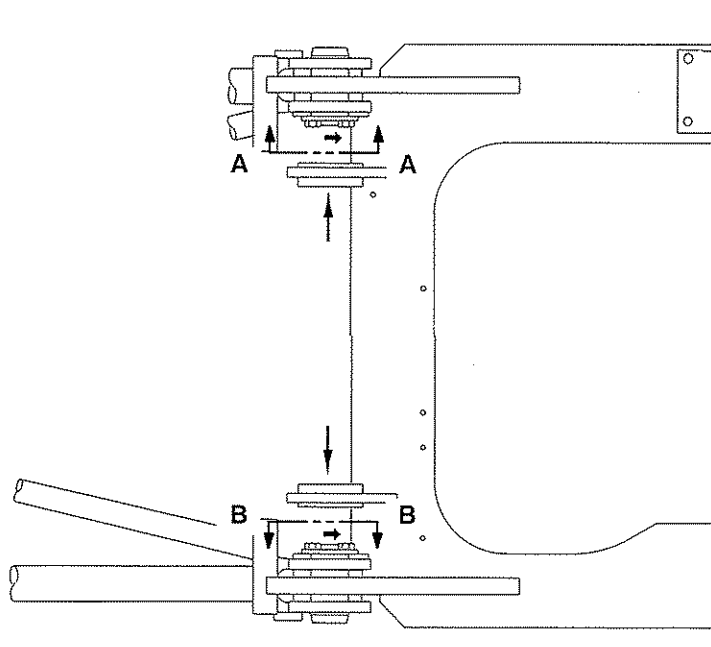

- 1. Top Keeper Plate
- 2. Capscrew
- 3. Plug
- 4. Boom Foot Pin

- 5. Bottom Keeper Plate
- 6. Grease Fitting
- 7. Shims

Figure 4-10
Boom Foot Pin

Operator's Manual

Boom Base Section Installation

The boom involves frequent reconfiguration, and thus, higher possibility of serious personal injury exists.

The following steps contain only the basic procedures and therefore all possible measures must be taken to prevent hazards.



WARNING

Prior to basic boom assembly, ensure that the side frames are in the correct position, the necessary counterweight(s) is (are) installed, and the gantry is in the high position.

1. Park the crane on a firm, level surface. Ensure that the side frames are installed and in the correct position.

Note: If crane is equipped with front mounted third drum, it must be removed to allow access to boom foot pins.

2. Use an auxiliary lifting device of suitable size or helper crane to lift and align the boom base section. Position boom base section so that both left and right lugs are brought into alignment.

CAUTION

Insert the boom foot pins from the inside of the boom. Ensure that the grease hole in the pin faces the bottom end of the boom.

3. Insert the boom foot pins from the inside of the boom. (Ensure that the arrow on the pins point to the rear of the crane and the grease hole in the pins face the bottom end of the boom base section.) Refer to Figure 4-10.

Note: The boom foot pins are not interchangeable. If they are not installed in the correct boom foot, the keeper plates cannot be installed and lubrication will be difficult.

Use shims [3/32" (2.4mm) and 1/64" (.4mm)] to adjust clearance in boom foot within 1/8" (3mm). The thicker shim must be placed next to the boom lug.

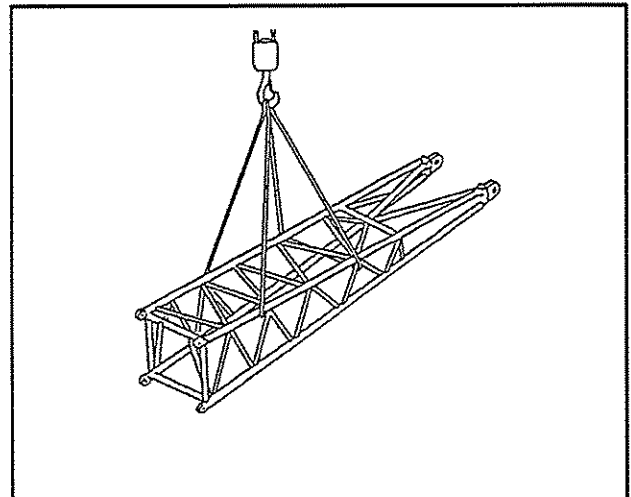

Figure 4-11
Boom Base Section Installation

4. Install keeper plates with capscrews to secure the boom foot pins. Refer to Figure 4-10.

Note: If the boom foot pin is installed in the correct lug, the top keeper plate will engage in the deeper slot in the pin.

5. Lower boom base section onto blocking. Refer to Figure 4-12.
6. Connect the backstops to the boom base section.
7. Connect the bridle/spreader bar to the handling links on the boom base section if required. Refer to Figure 4-13.
8. Reeve the boom hoist wire rope. Refer to "Boom Hoist Reeving Diagram" in Section 5 of this Operator's Manual.
9. Raise the boom base section and as the bridle/spread bar raises off the base section, flip the guide frame to the stored position and secure in place with pins and keeper pins. Refer to Figure 4-13.

Operator's Manual

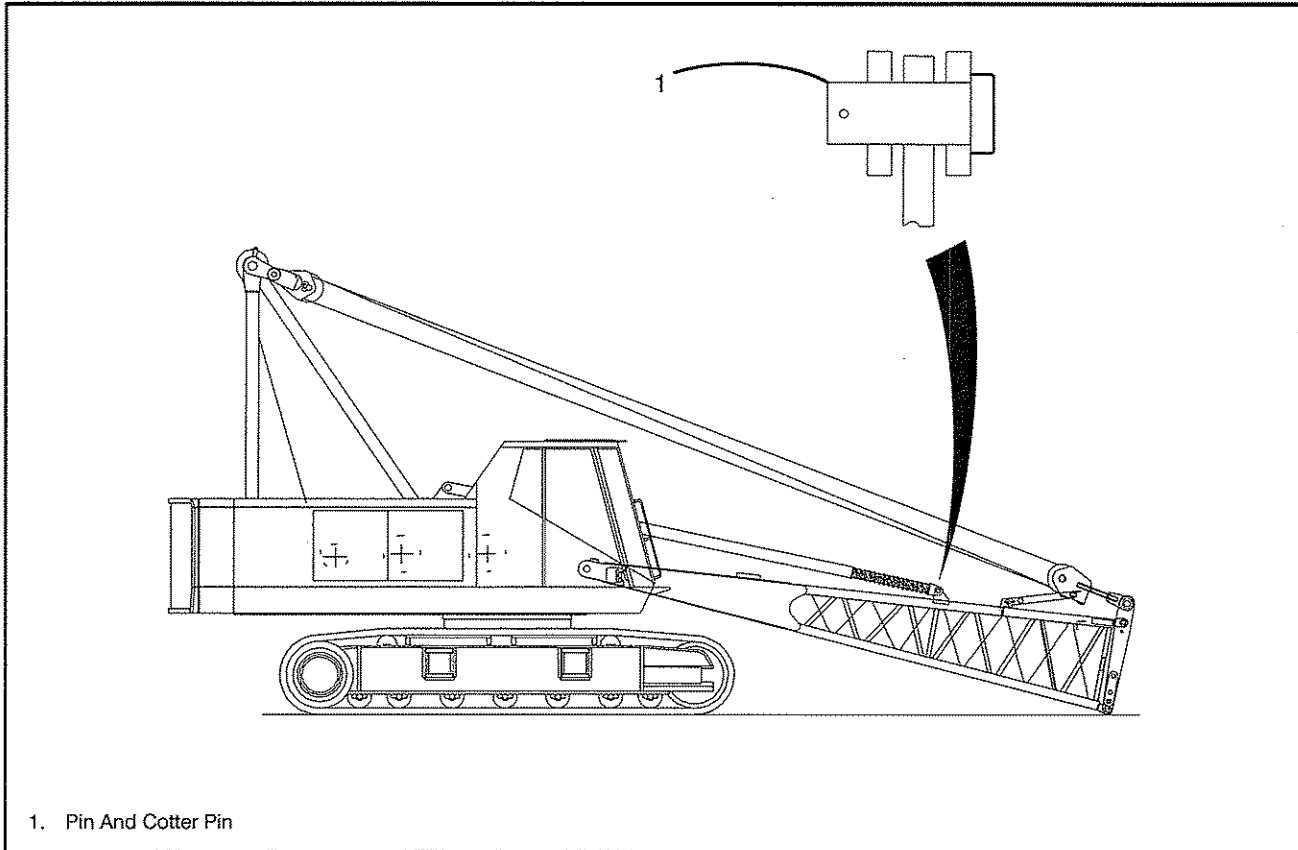

1. Pin And Cotter Pin

Figure 4-12
Lower The Boom Base Section Onto Blocking

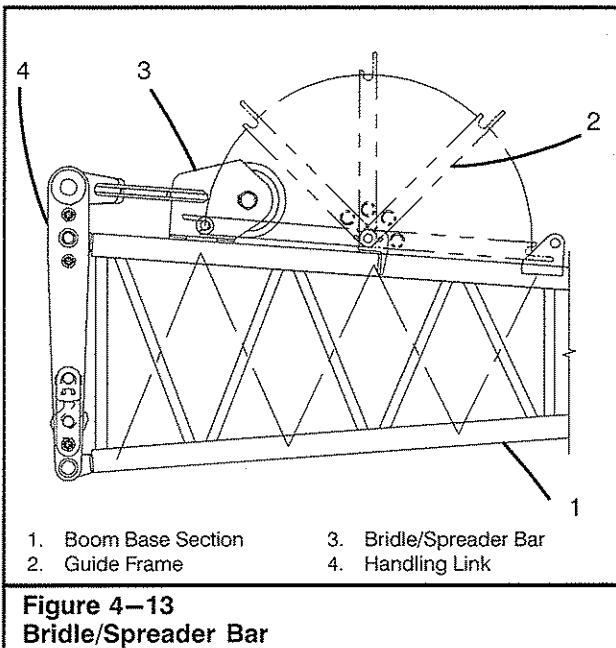

1. Boom Base Section 3. Bridle/Spreader Bar
2. Guide Frame 4. Handling Link

Figure 4-13
Bridle/Spreader Bar

Boom Base Section Removal

DANGER

To avoid serious injury, carefully read and fully understand the boom assembly and disassembly instructions in this Operator's Manual. Read and fully understand these instructions before beginning boom assembly or disassembly.

1. Read and fully understand all the safety instructions in this Operator's Manual.
2. Park the crane on a firm, level surface.

Note: If crane is equipped with front mounted third drum, it must be removed to allow access to boom foot pins.

3. Lower the boom base section and as the bridle/spreader bar approaches the base section, flip the guide frame to make contact with the pegs on the bridle/spreader bar.

Operator's Manual

4. Secure rear portion of the bridle/spreader bar to the base section.

Note: The bridle/spreader bar can be stored on the base section for transport or can be removed and transported separately.

5. Lower boom base section to the ground and allow the boom hoist wire ropes to go slack.
6. Remove boom hoist wire rope and properly store.
7. Disconnect the backstops from the boom base section. Refer to Figure 4–12.
8. Using a auxiliary lifting device of suitable size or helper crane, rig the boom base section for removal and lift to relieve the pressure on the boom foot pins. Refer to Figure 4–11.
9. Remove the capscrews and keeper plates which secure the boom foot pins. Refer to Figure 4–10.



DANGER

Do not stand or work inside or under the boom at anytime. If the boom falls, serious injury may result.

10. Remove the boom foot pins and shims. Refer to Figure 4–10.

Note: If crane is equipped with front mounted third drum, it must be removed to allow access to boom foot pins.

11. Using the auxiliary lifting device of suitable size or helper crane, lower the boom base section onto blocking.

Operator's Manual

Boom Assembly

Before beginning the boom assembly procedure, refer to the "Liftoff Capabilities" chart in the Crane Rating Manual. The base section lifting device can be used to perform all the lifting procedures required to assemble the boom.

1. Read and fully understand all the safety instructions in this Operator's Manual.

DANGER

To avoid serious injury, carefully read and fully understand the boom safety instructions outlined in this Operator's Manual. Failure to follow these instructions could result in serious personal injury or death.

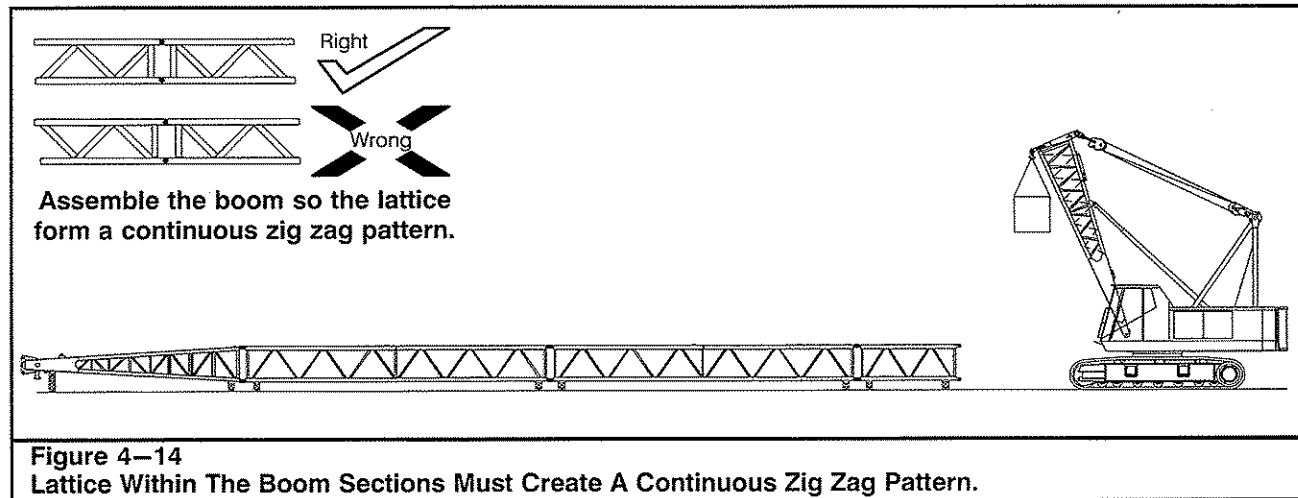

2. Park the crane on a firm, level surface.
3. Fully extend the side frames. Refer to "Extending The Side Frames" in Section 1 of this Operator's Manual for correct procedure.
4. Raise the gantry to the high position. Refer to "Raising The Gantry" in Section 1 of this Operator's Manual for correct procedure.
5. Install the counterweights. Refer to "Counterweight Installation And Removal" in Section 1 of this Operator's Manual for the correct procedure.
6. Install the boom base section if required. Refer to "Boom Base Section Installation" in this Section of this Operator's Manual.
7. Connect bridle/spreader bar to handling links on the boom base section, if required. Refer to Figure 4-15.
8. Using the base section lifting device, layout the top section and boom extensions. (If assembling basic boom, layout the top section only.) Pin sections together on blocking as shown in Figure 4-14. Position the boom sections as shown in the "Boom Make-Up-Chart" in this Section of this Operator's Manual. Ensure that the lattice form a continuous zig zag pattern from one section to another. Improper assembly will cause unequal loads to be carried through the boom, weakening the structure.
9. Connect boom sections to boom assemblies on the crane by installing top boom connecting pins.
10. Boom up until connecting pin holes line up and install bottom boom connecting pins. Do not lift head machinery off the ground during the assembly process. Refer to Figure 4-15.

CAUTION

Do not cantilever more than 70' (21.3m) of boom including the boom top section or 100 ft (30.5m) of boom extensions beyond the boom assembly pendant connection point.

Operator's Manual

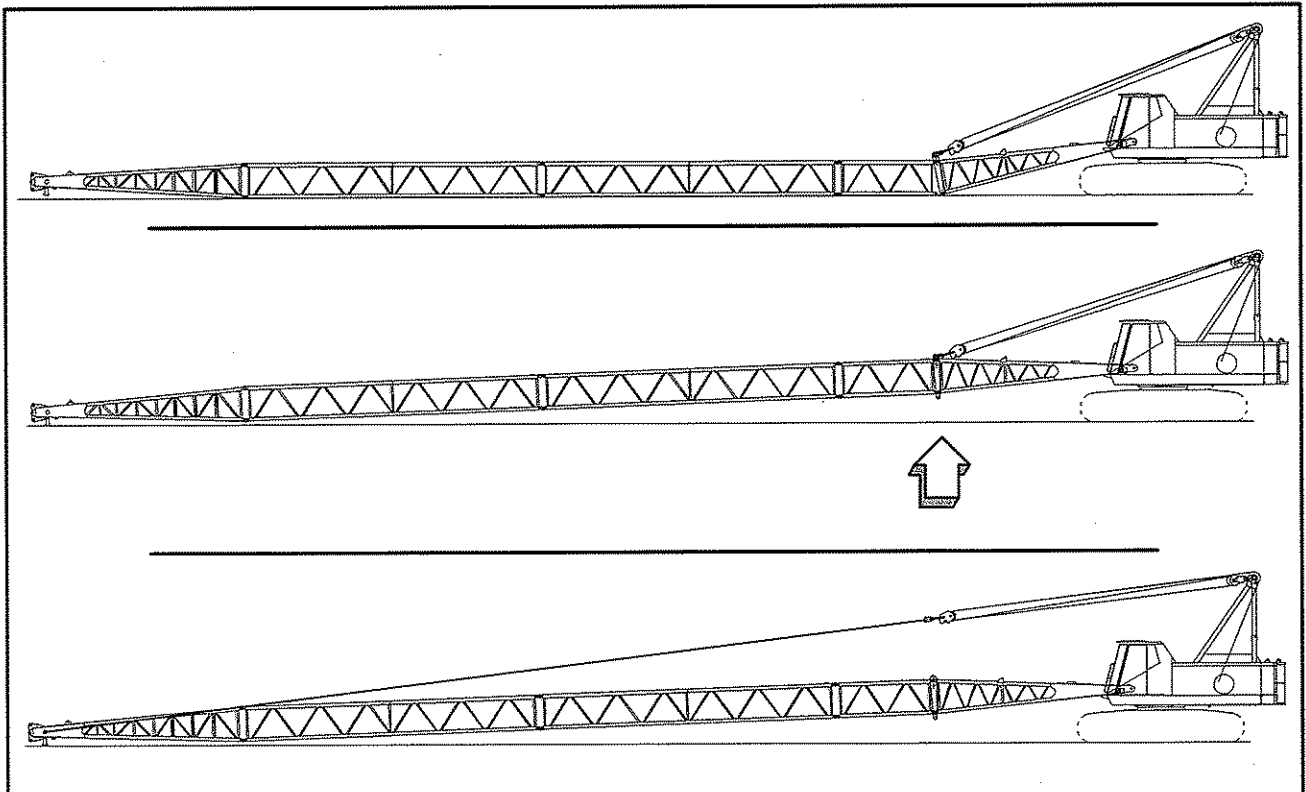

Figure 4–15
Pin connected angle boom assembly.

11. With boom head on ground, boom down until the boom hoist wire rope become slack. Disconnect the bridle spreader/bar from the connection point and add necessary pendants to install pendants up to the head machinery cross shaft. Refer to "Pendant Length Requirements" in this Section of this Operator's Manual.
12. Reeve wire rope on boom head machinery and hook block/hook ball as required. Refer to "Wire Rope Reeving Diagram" in Section 5 of this Operator's Manual.
13. Remove the bypass connector at the front of the upper and make the cable connections for the SML-10 System. Refer to "Rigging Mode" in Section 1 of this Operator's Manual.
14. Move the Rigging Mode switch to the OFF position and properly configure the SML-10 System. Refer to Section 1 of this Operator's Manual.
15. Carefully raise the boom to a working radius (where a capacity is listed in the Crane Rating Manual). Refer to "Lift-off Capabilities" in the Crane Rating Manual to determine proper crane setup during boom erection.

CAUTION

The main pendants must be properly connected to the headshaft links and the crane must have proper counterweight before lifting off complete attachment or damage may result.

16. Perform the angle/radius adjustment routine in the SML-10 System. Refer to "Boom Angle/Radius Adjustment" in Section 1 of this Operator's Manual.
17. Perform the self-weight adjustment routine in the SML-10 System. Refer to "Self-weight Adjustment" in Section 1 of this Operator's Manual.

Note: The self-weight adjustment needs to be done only once for each boom length.

18. Check the boom hoist limit switch operation. Refer to "Boom Hoist Limit Switch Adjustment" in this Section of this Operator's Manual.

Operator's Manual

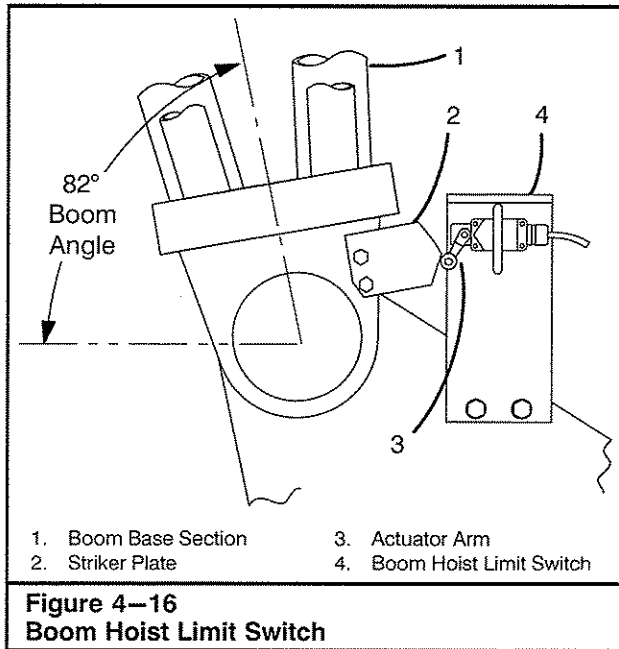

Boom Hoist Limit Switch Adjustment

The boom hoist limit switch is designed to prevent the boom from being raised beyond the maximum boom angle. In order to do this it must be properly adjusted. The boom hoist limit switch must be checked every time the boom is installed on the crane. Use the follow-

ing procedure to adjust the boom hoist limit switch. Refer to Figure 4-16.

1. Park the crane on a firm, level surface and set the boom onto secure blocking.
2. Manually operate the limit switch by pushing the actuator arm. Pull the boom hoist lever. Boom should not raise. Allow switch to return to original position and pull boom hoist lever again. Boom should raise indicating limit switch is functioning properly.
3. Slowly and carefully boom up until the boom reaches 82°. If limit switch does not actuate or actuates before boom reaches the 82° boom angle, limit switch must be adjusted.
4. Lower boom to a position which allows room to adjust the switch. Loosen setscrew in actuator arm. Slowly raise the boom to 82° angle. Tighten the setscrew.
5. Repeat Steps 3 and 4 until the boom hoist limit switch activates at 82°.

CAUTION

Do not raise the boom too tightly against the backstops. When setting down a heavy load at maximum boom angle, the recoil action of the boom could damage the boom or the backstops.



⚠ DANGER

Avoid injury to yourself. Boom can fall when pins are removed. Do not remove pins until boom is supported properly by blocking or boom suspension ropes are relocated as described in operator's manual. In the absence of sufficient information in the manual consult your Link-Belt distributor.

Figure 4-17
Boom Pin Danger Label

Boom Disassembly

1. Read and fully understand all the safety instructions in this Operator's Manual.

⚠ DANGER

To avoid serious injury, carefully read and fully understand the boom safety instructions outlined in this Operator's Manual. Failure to follow these instructions could result in serious personal injury or death.

2. Park the crane on a firm, level surface. Position the upper directly over the front or rear of the lower and engage the travel swing lock.
3. Lower the boom top section onto secure blocking and as the bridle/spreader bar approaches the base section, flip the guide frame to make contact with the pegs on the bridle/spreader bar.
4. Continue to boom down until bridle/spreader bar pin holes align with handling links.. Disconnect main pendants from bridle spreader/bar. Pin the bridle spreader/bar to the handling links and secure with keeper pins. Refer to Figure 4-15.
5. With boom top section resting on secure blocking, boom up enough to take the load off the bottom boom connecting pins at connecting point, or any point outward from connecting joint without lifting boom top section off the blocking.

CAUTION

Do not cantilever more than 70' (21.3m) of boom including the boom top section or 100 ft (30.0m) of boom extensions beyond the boom assembly pendant connection point.

6. Remove bottom connecting pins at joint to be disassembled. Boom may be disassembled from connecting joint or any joint outward from the connecting joint.
7. Lower boom to secure blocking and remove top boom connecting pins.
8. Carefully raise the boom and pull away from the boom.

Note: Handling links may be left installed on the boom to facilitate future boom assembly and disassembly.

9. If required, remove the boom base section. Refer to "Boom Base Section Removal" in this Section of this Operator's Manual.

Operator's Manual

Boom Folding/Unfolding System

The 50 ft (15.2) or 70 ft (21.3m) boom can remain installed on the crane in a folded position while traveling of transporting. Use of the boom folding system eliminates the need to disassemble all of the boom. Use the following procedure to fold or unfold the boom.

Boom Folding System

1. Park the crane on a firm, level surface. Position the upper directly over the front or rear of the lower.
2. Raise the gantry to the high position. Refer to "Raising And Lowering The Gantry" in Section 1 of this Operator's Manual.
3. Remove any optional attachments from the boom (jib, tip extension, etc.).
4. Install the folding wheel in line with the boom and will roll on the ground as shown in the top illustration in Figure 4-18. Secure with lock pin.
5. Remove the main boom pendants and pin the bridle/spreader bar to the handling links at the end of the base section.
6. If required, install the folding links to the bottom connecting lugs as shown in detail "B" Figure 4-18. Ensure the folding link pin holes are directly in-line with the boom connecting pins.

Note: Once installed, the folding links do not have to be removed from the boom extensions.

7. Remove all four connecting pins at the folding link connection.
8. Slowly boom up until the boom top section is vertical. Raise the boom just enough to rotate the folding wheel. Remove the hitch pin, rotate wheel 180 degrees and install hitch pin.
9. Lower boom until folding wheel contacts the ground. Travel forward and slowly lower boom allowing the folded position of the boom to move in toward base of the boom with folding wheel on the ground.
10. Continue to lower boom until the storage links can be installed between the base section and top section. Install storage links. Refer to detail "A" Figure 4-18.

11. Raise boom until folding wheel clears the ground. Remove the hitch pin and rotate the folding wheel 90 degrees and pin.
12. Load the crane onto a transport vehicle. Refer to Figure 1-86 and "Transporting The Crane" in Section 1 of this Operator's Manual.
13. After crane has been loaded for transport, lower the gantry to the lower position. Refer to "Raising And Lowering The Gantry" in Section 1 of this Operator's Manual.

Boom Unfolding System

1. Raise the gantry to the high position. Refer to "Raising And Lowering The Gantry" in Section 1 of this Operator's Manual. Raise boom and unload crane from the transport vehicle.
2. Park the crane on a firm, level surface. Position the upper directly over the front or rear of the lower.
3. Raise boom until folding wheel clears the ground. Remove the hitch pin and rotate the folding wheel 90 degrees and pin. Refer to Figure 4-19.
4. Lower boom until the folding wheel contacts the ground and storage link can be removed between the base section and top section.
5. Slowly raise boom so that the folded position of the boom will move out away from the base of the boom with folding wheel on the ground.
6. Continue to boom up until the boom top section is vertical. Raise the boom just enough to rotate the folding wheel. Remove the hitch pin, rotate wheel 180 degrees and install hitch pin. Place blocking behind the folding wheel.
7. Travel rearward and slowly boom down until the folded position of the boom starts to move out from the base of the boom with folding wheel on the ground. Once the boom starts moving outward, discontinue travel.
8. Slowly lower the boom until all four boom connection pins can be installed at the folding link connection. Install all four boom connecting pins.
9. If required, remove the lock pin and remove the folding wheel.
10. Install the main boom pendants.
11. Install any optional attachments if required (jib, tip extension, etc.).

Operator's Manual

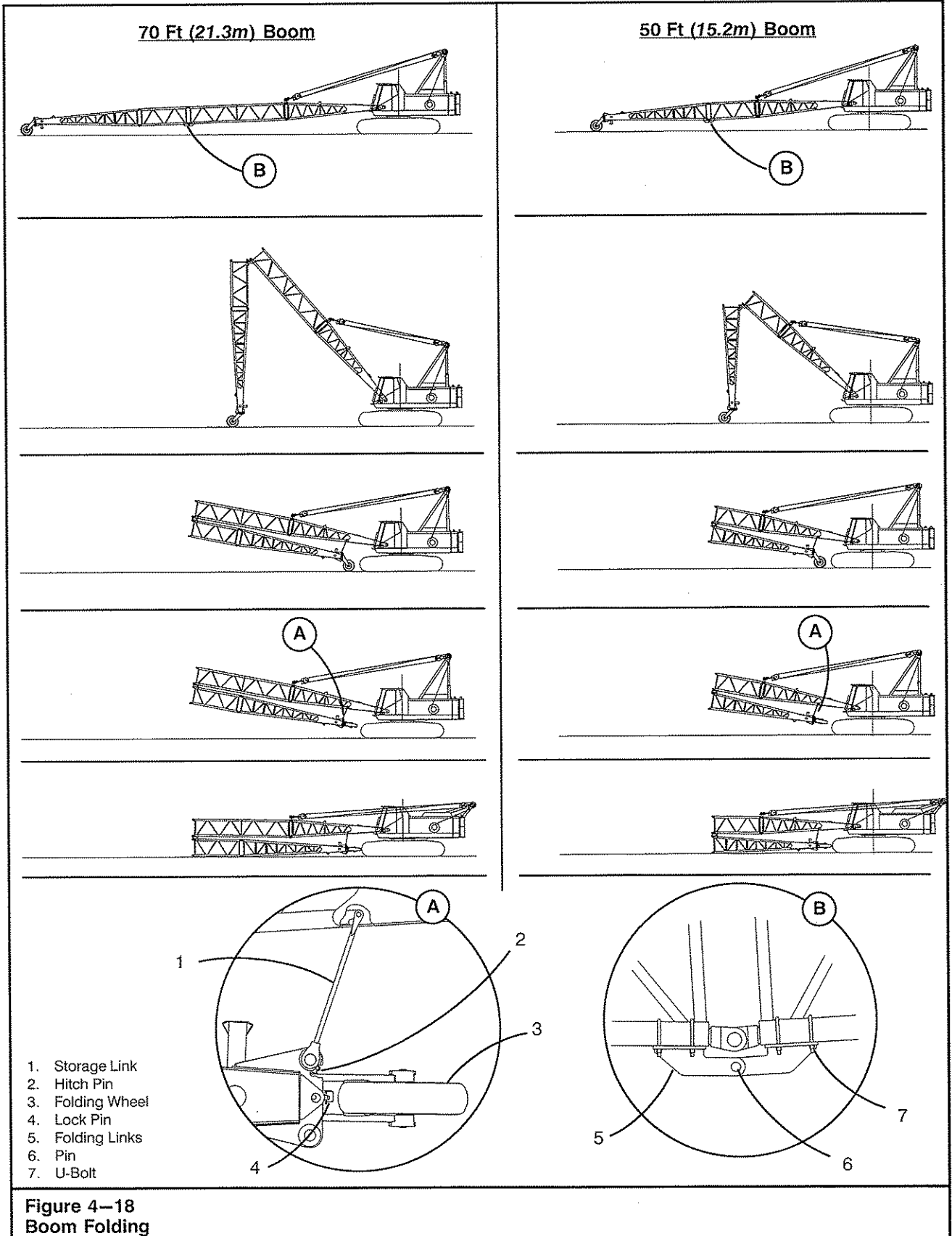

1. Storage Link
2. Hitch Pin
3. Folding Wheel
4. Lock Pin
5. Folding Links
6. Pin
7. U-Bolt

Operator's Manual

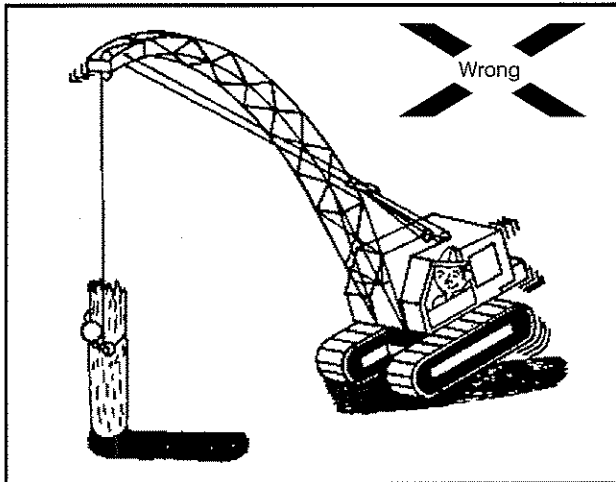

Figure 1-12
Extracting Pilings

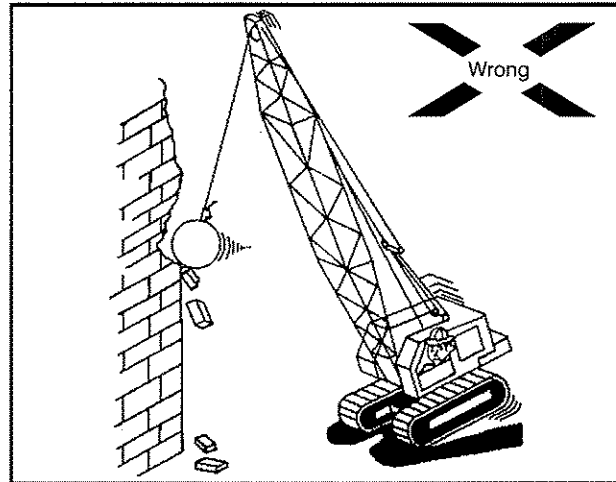

Figure 1-13
Demolition Work

28. When using a clamshell bucket on demolition work and taking a bite on a piece of unknown weight, be ready to release the closing line as more weight than can be lifted may break loose. Be prepared to drop the load. Always stay within the boom length and load limitations shown in the Crane Rating Manual. Failure to do so may create fatigue which can lead to eventual failure.
29. When dismantling a structure where a portion is being cut loose while suspended by a crane, ensure the weight of the portion being cut loose is known, and the crane pull on the load is equal to the weight. The point of attachment must be directly above the center of gravity of the load. The hoist wire rope must be vertical. This is an extremely hazardous operation. The services of a professional engineer should be used to plan and supervise such lifts.
30. Cold weather operation requires some special attention by the operator to allow for changes in everyday routines:
 - a. Clean the crane, especially the boom, of accumulated amounts of ice or snow. Operating the crane with an ice covered boom is dangerous. The added weight of the ice or snow can drastically reduce the capacity of the crane. Also, falling ice may pose danger for ground personnel.
 - b. Clean all snow and ice from steps, ladders, platforms, etc. to eliminate slippery walking surfaces.
 - c. If cold weather starting aids are provided on the crane, use them. The use of aerosol starting sprays can be dangerous if the manufacturer's directions are not closely followed.
 - d. Pay close attention to the gauges in the operator's cab when starting the engine. Normal "warm up" times will be longer. Confirm that pressures and temperatures are within normal ranges before beginning operations.
 - e. Always handle flammable materials according to the supplier's instructions. Propane, diesel, or other fuel, for auxiliary heaters, can be dangerous if not properly handled. Do not store such fuels on the crane.
 - f. Use caution when lifting any load during freezing weather, as it may be frozen to the ground or the supporting surface. The added tension, to break the load free, could cause an unexpected overload situation. Also, when the load does finally break loose it could create an erratic motion causing damage or injury.
 - g. At the end of the work shift, park the crane where it will not freeze to the ground. Major damage to the drive train could occur while trying to free the crane from a frozen surface.

Operator's Manual

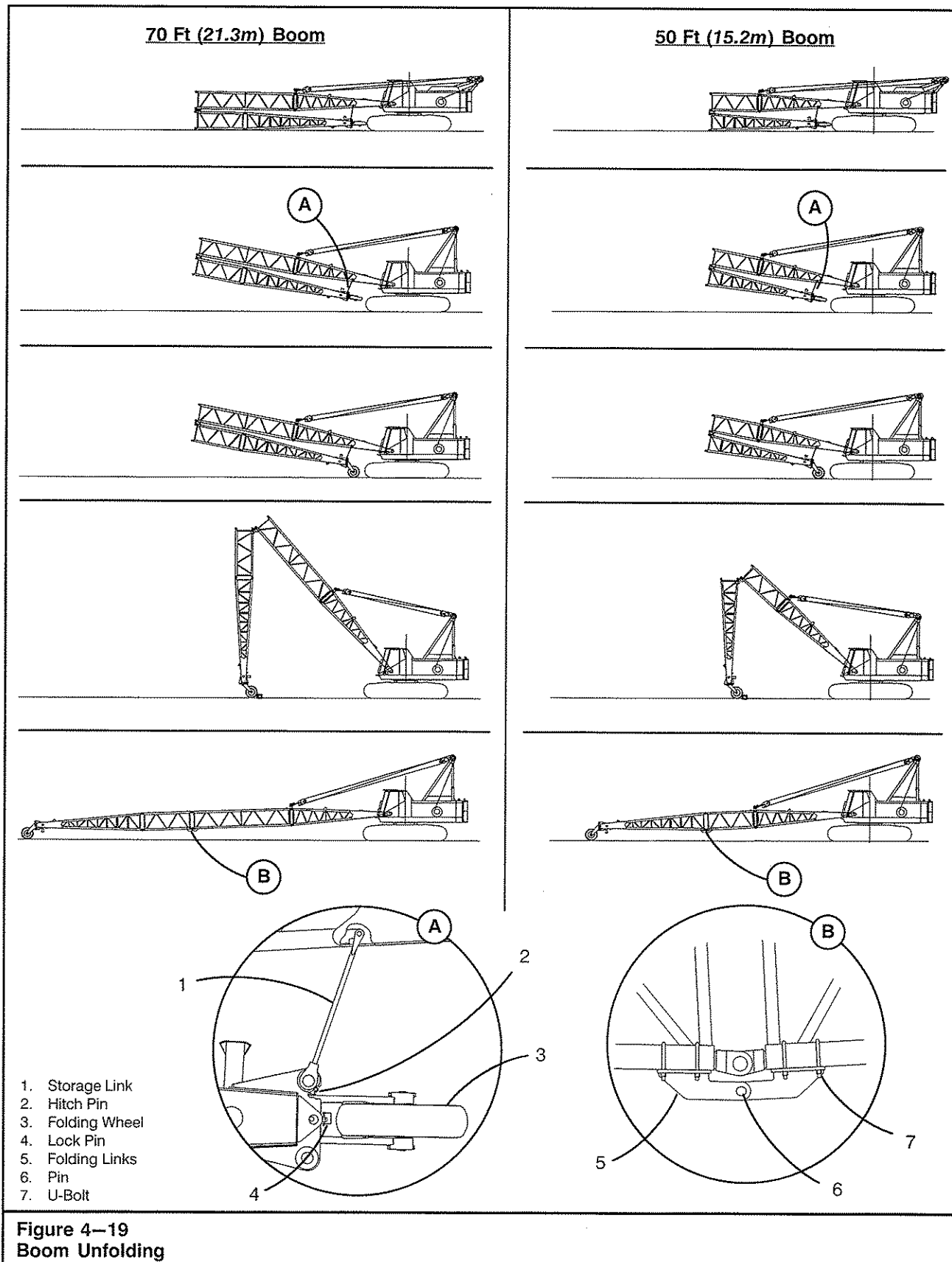
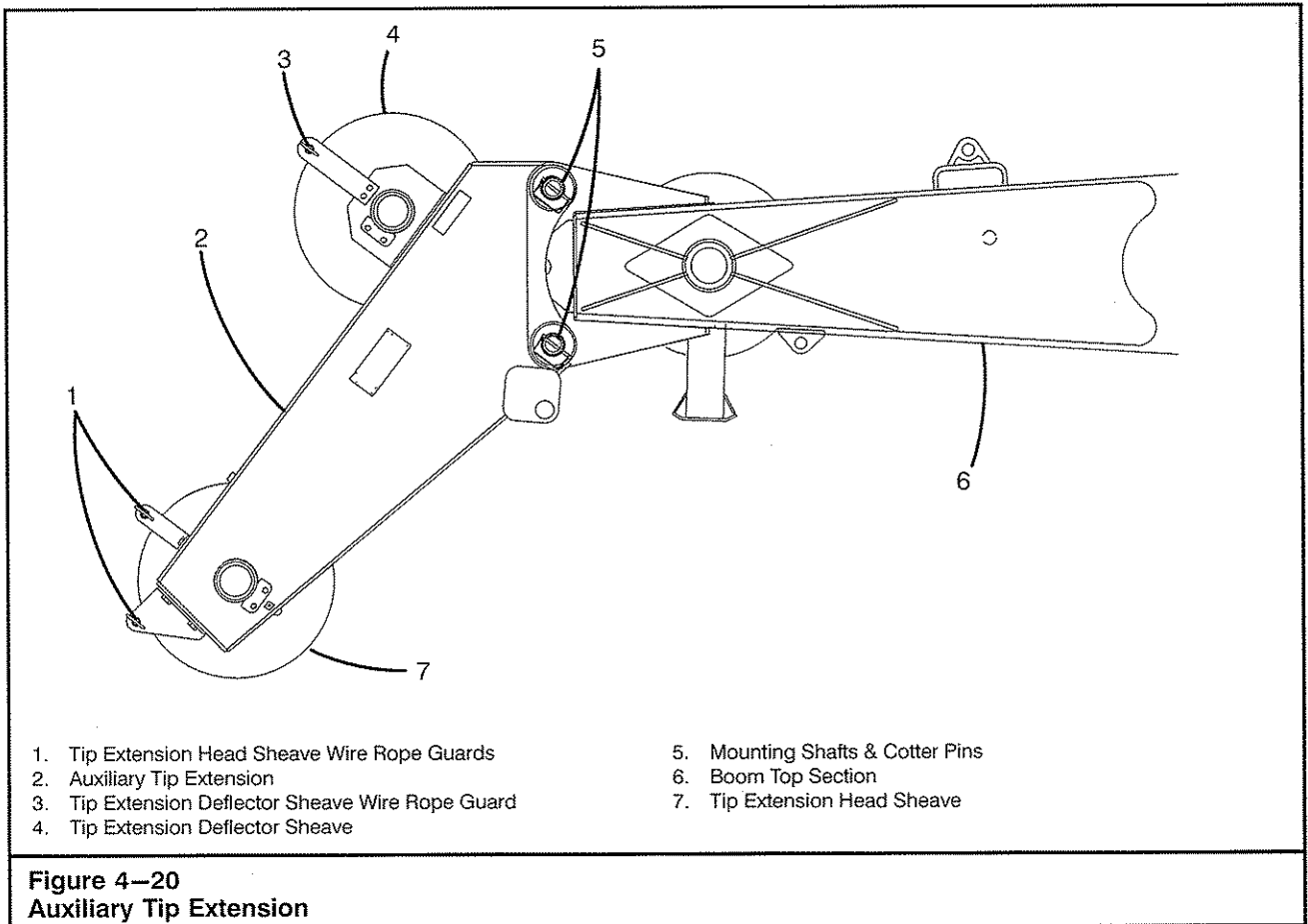

Figure 4-19
Boom Unfolding



Auxiliary Tip Extension

An auxiliary tip extension (offset at 45°) can be added to the boom top section for 1 or 2 part auxiliary hoist line use. The tip extension is secured to a bracket on the boom top section with shafts and cotter pins. Reeve the hoist line over the deflector sheave and head sheave. All wire rope guards must be installed.

The crane monitoring system used today does not include capacities for the auxiliary tip extension. Before making any lifts with the auxiliary tip extension, refer to "Maximum Allowable Capacities for Auxiliary Tip Extension" in the Crane Rating Manual to ensure load is within the rated capacity of the auxiliary tip extension.

The auxiliary tip extension adds weight to the boom which must be considered in the lifting capacities. When making lifts from the main boom with the tip extension installed, refer to "Capacity Deductions For Lifting Off Main Boom Hook With Auxiliary Tip Extension Installed" in the Crane Rating Manual for the appropriate deductions from lifting capacities.



WARNING

Do not lift a load with the auxiliary tip extension and the main boom at the same time. Lifting two loads at the same time may cause boom failure.

Operator's Manual

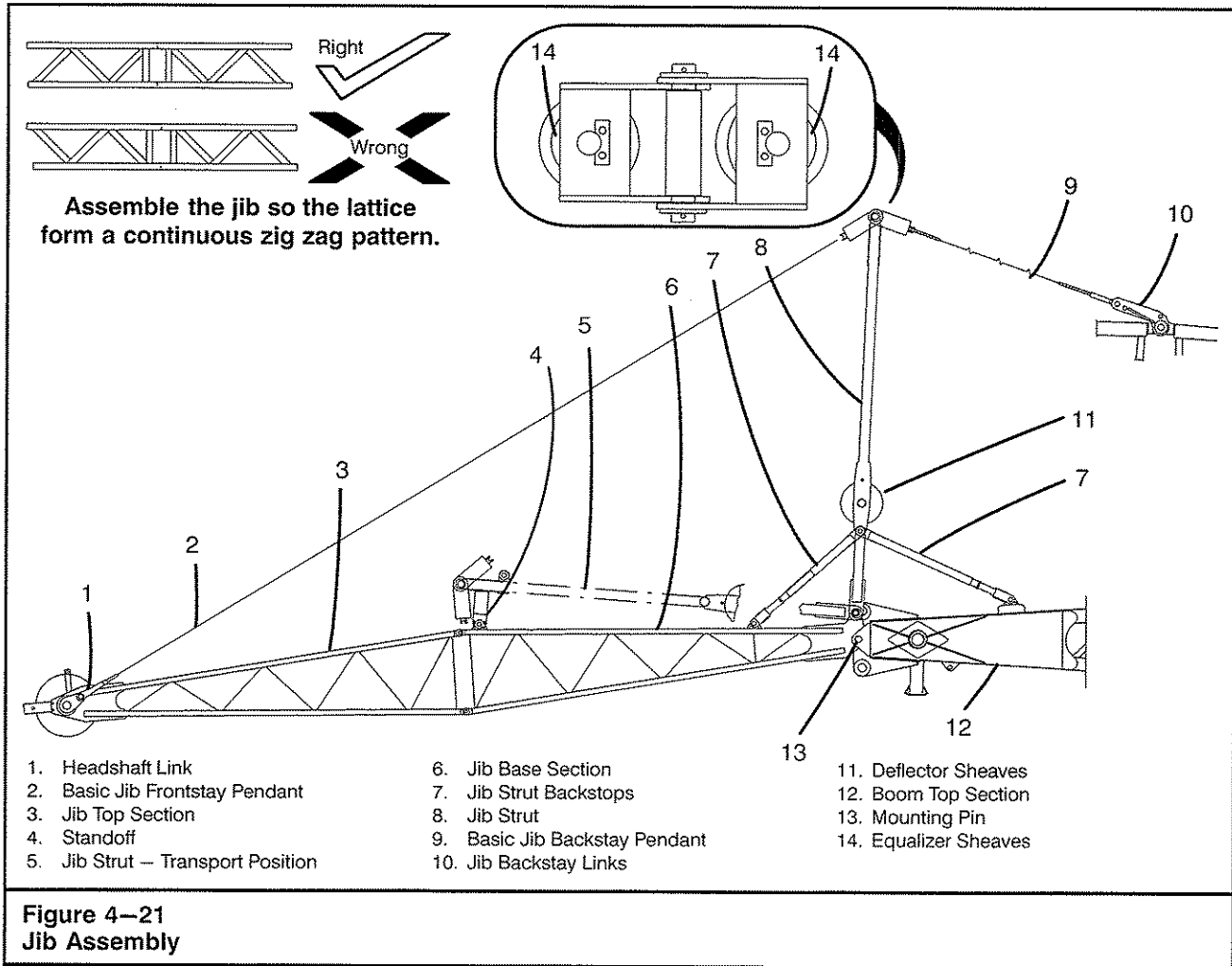

Tubular Jib Assembly And Disassembly

The following procedures outline the recommended steps necessary for safe jib assembly, disassembly, and installation on the boom. Depending upon job site conditions and the availability of auxiliary equipment, these procedures can be modified using only known, proven, safe procedures to increase the efficiency of the jib installation.

Regardless of the specific method used for the installation of the jib, certain procedures must be followed to prevent reckless or inadvertent dropping of the jib or jib mast. Improper assembly or disassembly of the jib also can lead to serious personal injury or death. The jib could be damaged beyond repair also. Any questions regarding safe jib assembly or disassembly procedures should be directed to the Link-Belt Distributor.



DANGER

To avoid serious injury, carefully read and fully understand all jib assembly, disassembly, and safety instructions outlined in this Operator's Manual. Failure to follow these instructions could result in serious personal injury or death.

The basic jib is 20' (6.0m) long and consists of a 10' (3.0m) top and a 10' (3.0m) base section held together by four pins. Additional extensions are available in 10' (3.0m) lengths to assemble a maximum 50' (15.2m) of jib. The jib mounts to lugs on the boom top section.

There are limitations as to the amount of boom a jib can be mounted. See the Crane Rating Manual for allowable boom and jib lengths.

Operator's Manual

Safety Instructions

The following points must be observed while performing any jib assembly or disassembly:

1. Read and fully understand the instructions outlined in this Operator's Manual before attempting to assemble or disassemble the jib.
2. Do not stand inside, on top, or under the jib at any time while assembling or disassembling the jib.
3. To avoid personal injury, do not climb, stand, or walk on the jib. Use a ladder or similar device to reach necessary areas.
4. Each individual jib section must be adequately supported before attempting to disassemble the jib. Removing the connecting pins from the jib before it is supported, may allow the jib to fall.
5. Stay clear of pinch points when aligning jib section connecting points. Never place your fingers in connecting pin holes.
6. Use caution when disconnecting the dead end of wire ropes. Reeved wire rope can become twisted on the sheaves. When the dead end pin or socket is removed, the wire rope may spin.
7. Refer to the Crane Rating Manual for the maximum boom plus jib lengths allowed.

Jib Capacity

The jib capacity is limited by the strength of jib components and stability of the crane for any combination of the following variables:

Boom length

Jib length

Angle of jib with respect to ground

Load radius

Jib Frontstay Pendants

The basic jib frontstay pendant, which runs from the headshaft link, around the equalizer sheave on the jib strut, and back to the other headshaft link, is 41' 5" (12.6m) long. For addition of a jib extension, one pair 9' 4" (2.8m) pendants must be added to the basic jib frontstay pendant for each 10' (3.0m) extension.

Before making any lifts with the jib, always refer to the jib capacities in the Crane Rating Manual. Confirm that the load being lifted is within the rated capacity of the jib under the existing conditions.

Jib Strut

The jib strut pins to a set of lugs on the jib base section. Two pairs of jib strut backstops are used.

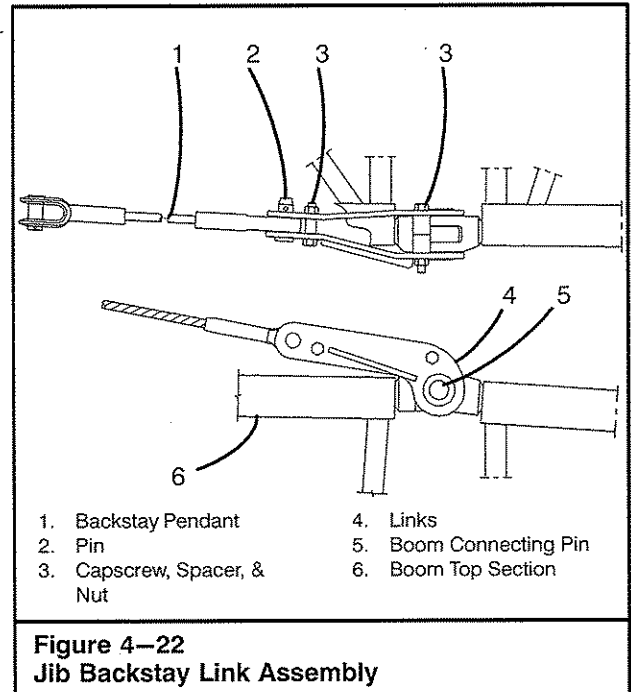

Figure 4-22
Jib Backstay Link Assembly

Jib Backstay Pendant

The basic jib backstay pendant is 43' 1" (13.1m) long. It runs from a set of links at the base of the boom top section, around the equalizer sheave on the jib strut and hooks to another set of links at the other side of the base of the boom top section. Refer to Figure 4-22.

Changing Jib Angle

To change the jib angle with respect to the boom, proceed as follows:

1. The basic jib backstay pendant positions the jib at a 5° offset to the boom.
2. To position the jib at a 17.5° angle, one 4' 0" (1.2m) pendant is required to be combined with the basic jib backstay pendant.
3. To position the jib at a 30° angle, two 4' 0" (1.2m) pendants are required to be combined with the basic jib backstay pendant.

Tubular Jib Assembly And Installation

1. Layout the jib on blocking and assemble the desired length. Refer to Figure 4-21.
2. Pin the jib strut to the jib base section.
3. Maneuver the crane to align the connecting lug on the boom top section with the jib foot mounting holes or use an auxiliary lifting device to lift the jib into place.

Operator's Manual

4. With the jib strut resting on the top of the jib, reeve the basic jib frontstay pendant (plus two additional pendants for each additional jib extension) from the jib headshaft link, around the equalizer sheave on the jib strut, and back to the other jib headshaft link.
5. Reeve the basic jib backstay pendant (plus additional sets of pendant(s) if the jib is other than a 5 degree angle) around the rear equalizer sheave on the jib strut.



WARNING

Do not stand or work below the jib strut at anytime. If the jib strut falls you may be injured or killed.

6. With a helper crane, raise the jib strut and connect the front jib strut backstops.
7. Disconnect the helper crane from the jib strut. If necessary, use the helper crane to raise the jib top section to allow connection of the jib backstay pendants to the links on the boom upper section.

Note: Two sets of backstay links are required. The links fit over the lifting lug at the pin connection and each are held together by two capscrews with a spacer between the links.

8. Assemble the rear jib strut backstops between the jib strut and the boom top section. If necessary, raise the main boom up to get sufficient distance between jib strut and boom top section to install jib strut backstops.

9. Properly reeve the jib winch wire rope. Refer to "Wire Rope Reeving Diagram" in Section 5 or this Operator's Manual.
10. Refer to "Liftoff Capabilities" in the Crane Rating Manual before operating the crane. Refer to the Crane Rating Manual for all lifting capacities.

Changing Jib Length

1. If it is necessary to change the length of the jib (adding or removing jib sections), the jib must be lowered onto blocking to make the change. Follow the "Tubular Jib Disassembly" procedures to lower the jib and disassemble it as required. If removing jib sections to shorten the jib, remove them at this point. If adding jib sections, follow the procedures in "Tubular Jib Assembly" to assemble the desired jib length.

Tubular Jib Disassembly

1. Lower the jib onto secure blocking.
2. Remove the winch wire rope and secure it at the winch.
3. Using a helper crane, attach a sling to the jib strut to control it.
4. Remove the frontstay and backstay pendants and store properly.
5. Remove the jib strut backstops and store properly.
6. Lower the jib strut down on the standoff on the jib base section using the helper crane.
7. Remove the mounting pin to disconnect the jib base section from the boom top section.

Operator's Manual

Table Of Contents

Crane Rating Manual And Serial Number	5-1
Wire Rope Capacity Chart	5-1
Wire Rope Specifications	5-1
Wire Rope Diameter	5-1
Wire Rope Inspection And Replacement Recommendations	5-3
Wire Rope Inspection	5-4
Wire Rope Replacement	5-4
Wire Rope Installation	5-5
Uncoiling/Unreeling Wire Rope	5-5
Anchoring Wire Rope To Drum	5-5
Winding Wire Rope On Drum	5-6
Causes Of Irregularly Wound Wire Rope	5-6
Wire Rope Reeving	5-6
Sockets And Wedges	5-7
Socket & Wedge Assembly — Without Extended Wedge	5-8
Socket & Wedge Assembly — With Extended Wedge	5-10
Wire Rope Sockets With Clips	5-12
Wire Rope Clip Installation	5-12
Wire Rope Break-In	5-13
Cutting Wire Rope	5-14
Rotation Resistant Wire Rope	5-14
Hook Ball Usage With Rotation Resistant Wire Rope	5-14
Non-Swivel Usage	5-14
Swivel Usage	5-14
Wire Rope Inspection	5-14
Wire Rope Reeving Diagrams	5-15
Boom Hoist Reeving Diagram	5-16
Crane Specifications	5-17
Dimensions	5-17
Upper Structure	5-19
Frame	5-19
Engine	5-19

Operator's Manual

Hydraulic System	5-19
Load Hoist Drums	5-19
Optional Third Hoist Drum	5-19
Optional Fourth Hoist Drum	5-20
Boom Hoist Drum	5-20
Boom Hoist System	5-20
Swing System	5-20
Counterweight	5-20
Operator's Cab	5-20
Rated Capacity Limiter System	5-20
Machinery House	5-20
Catwalks	5-20
Lower Structure	5-21
Carbody	5-21
Side Frames	5-21
Travel and Steering	5-21
Attachment and Options	5-21
Conventional Angle Boom	5-21
Tubular Jib	5-21
Auxiliary Tip Extension	5-22
Pile Driver Lead Adaptor	5-22
Boom Folding Equipment	5-22
Transport Weights	5-22
Working Weights	5-23
Transport Drawings	5-23
Load Hoist Performance	5-24
Attachments	5-26
Main Boom Make-up	5-27
Duty Cycle Working Range Diagrams	5-28
Main Boom Working Range Diagram	5-30
Jib Attachment Make-up	5-31
Jib Attachment Working Range Diagram	5-32

Operator's Manual

Crane Rating Manual And Serial Number

A Crane Rating Manual is in the operator's cab. This Crane Rating Manual has the crane serial number on it. The serial number must be used with any correspondence with the Link-Belt Distributor or factory concerning parts or warranty. The Crane Rating Manual also lists the maximum allowable lifting capacities for the crane. The Crane Rating Manual should be checked for the proper lifting capacities before making any lifts.

If the Crane Rating Manual becomes lost, damaged, or unreadable, it must be replaced before operating the crane. Information contained in the Crane Rating Manual is important and failure to follow the information could result in an accident. A replacement Crane Rating manual can be ordered through your Link-Belt Distributor.



WARNING

The Crane Rating Manual supplied with the crane is the only authorized listing of lifting capacities for the crane. It supercedes any other printed literature which lists lifting capacities. It alone is to be used for determining crane capacities.

Wire Rope Capacity Chart

The Wire Rope Capacity Chart gives the maximum lifting capacities based on wire rope strength. A typical example is shown Figure 5-1. It is in the Crane Rating Manual. It lists the maximum load that should be lifted with different sizes and types of wire rope using one to eight parts of line. The weights shown are based on wire rope strength alone. Exceeding these load weights may result in wire rope breakage.

Before making a lift, compare the weight being lifted with the chart (remember to add the weight of the hook block, hook ball, slings, and riggings to the actual load weight). Check the chart for the number of parts of line required to make the lift. Use at least that number of parts of line to make the lift. When making a lift with

more parts of line than is needed to make the lift, refer to the Crane Rating Manual for the deduct required for the weight of the extra wire rope required to reeve the extra parts of line. The extra parts of line act as additional load weight.



WARNING

Do not exceed the capacities on the Wire Rope Capacity Chart or crane capacity in the Crane Rating Manual, whichever is less, when making a lift. Serious personal injury or major crane damage may result.

Wire Rope Specifications

The specifications for the wire rope used on this crane are on the Wire Rope Capacity Chart in the Crane Rating Manual. Refer to Figure 5-1. Always refer to the Wire Rope Capacity Chart in the Crane Rating Manual, and the Parts Manual, when ordering replacement wire rope.

Wire Rope Diameter

In standard practice, the nominal diameter of wire rope is the minimum acceptable diameter. It is always made larger, not smaller, than the nominal diameter according to the allowable tolerances shown in the following chart:

Nominal Wire Rope Diameter	Allowable Limits	
Thru 1/8" (3.2mm)	-0	+8%
Over 1/8" (3.2mm) thru 3/16" (4.8mm)	-0	+7%
Over 3/16" (4.8mm) thru 5/16" (8.0mm)	-0	+6%
Over 5/16" (8.0mm) and larger	-0	+5%

Wear and stress tend to reduce the diameter. It should be measured periodically and replaced if the size reduction from the nominal diameter is more than the reductions listed in the chart on page 5-4. It should always be measured across the largest diameter that will fit inside a true circle. Refer to Figure 5-2.

Operator's Manual

Wire Rope Capacity – Load Hoist Wire Ropes					
Parts of Line	3/4"		5/8"		Notes
	Type "DB"	Type "RB"	Type "ZB"	Type "WB"	
1	16,800	12,900 *	11,000 **	13,600 *	Capacities shown are in pounds and working loads must not exceed the ratings on the capacity charts in this Crane Rating Manual. Study Operator's Manual for wire rope inspection procedures.
2	33,600	25,800	22,000	27,200	
3	50,400	38,700	33,000	40,800	
4	67,200	51,600	44,000	54,400	
5	84,100	64,500	55,000	68,000	
6	100,800	77,400	66,000	81,600	
7	117,600	90,300	77,000	95,200	
8	134,400	103,200	88,000	108,800	
LBCE Type	Description				
DB	6 x 26 (6 x 19 Class) – Warrington Seale – Extra Improved Plow Steel – Preformed – Right Lay – Regular Lay – I.W.R.C.				
RB*	19 x 19 Rotation Resistant– Extra Extra Improved Plow Steel – Preformed – Right Lay – Regular Lay – Swaged.				
ZB**	34 x 19 Class – Non-Rotating – Extra Improved Plow Steel – Right Regular or Right Lang Lay				
WB*	8 Strand – Regular Lay				
M	6 X 19 Class – Extra Improved Plow Steel – Lang Lay.				
* Use of swivel end with 1 part of line is not recommended.					
** Swivel end is recommended for operation with 1 part of line.					
Note: The official Wire Rope Capacity Chart is in the Crane Rating Manual. Use it to determine the correct parts of line required for the given wire rope type and diameter.					
Figure 5–1 Typical Wire Rope Capacity Chart					

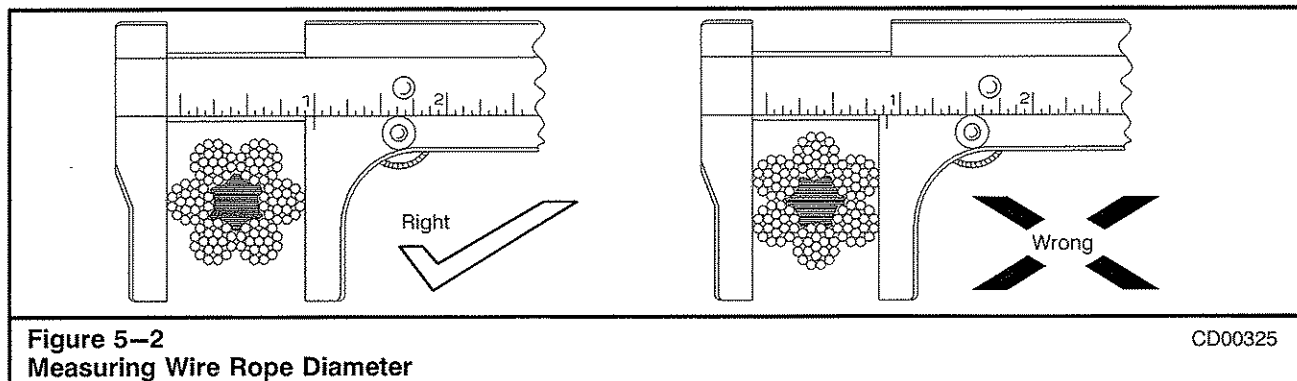

**Figure 5–2
Measuring Wire Rope Diameter**

CD00325

Operator's Manual

WIRE ROPE INSPECTION REPORT											
Machine _____			Owned By _____			Machine Location _____					
Date of Inspection _____			Wire Rope Application _____			Wire Rope Description _____					
Manufacturer's Identification. No. _____						Applicable Standards _____					
Criteria for Removal			1/3 of outside wire diameter	1							
Location on Wire Rope	Measured Diameter	Broken Wires		Excessive Wear	End Attachments			Rope Damage	Sheave Condition	Drum Condition	Wire Rope Lay Measurement
		In 1 Wire Rope Lay	In 1 Strand of 1 Lay		Broken Wires	Corrosion of Wire Rope	Fitting Condition				
Signature: _____											
Figure 5-3 Typical Wire Rope Inspection Report											

Wire Rope Inspection And Replacement Recommendations

There are many reasons for wire rope deterioration, such as abrasion, corrosion, fatigue, crushing, kinking, and forces causing damage or abuse to the wire rope during normal usage.

When wire rope is replaced, use the type specified on the Wire Rope Capacity Chart in the Crane Rating Manual. Cranes are designed to use a specific type and size of wire rope. Using wire ropes other than

those recommended, may result in short life or even breakage of the wire rope.

According to ASME standards, all wire ropes in active service **MUST BE** visually inspected daily. A qualified, trained person should be appointed to conduct the inspection. Also on a monthly basis, that person is required to inspect all wire ropes and keep a dated, written record noting any damage and recording when wire ropes are replaced.

These inspections should be done to determine the degree of deterioration of the wire rope at any given section (refer to Wire Rope Replacement). This will determine the suitability of the wire rope for continued service. A sample inspection report is shown in Figure 5-3. (It can be reproduced and used if desired.)

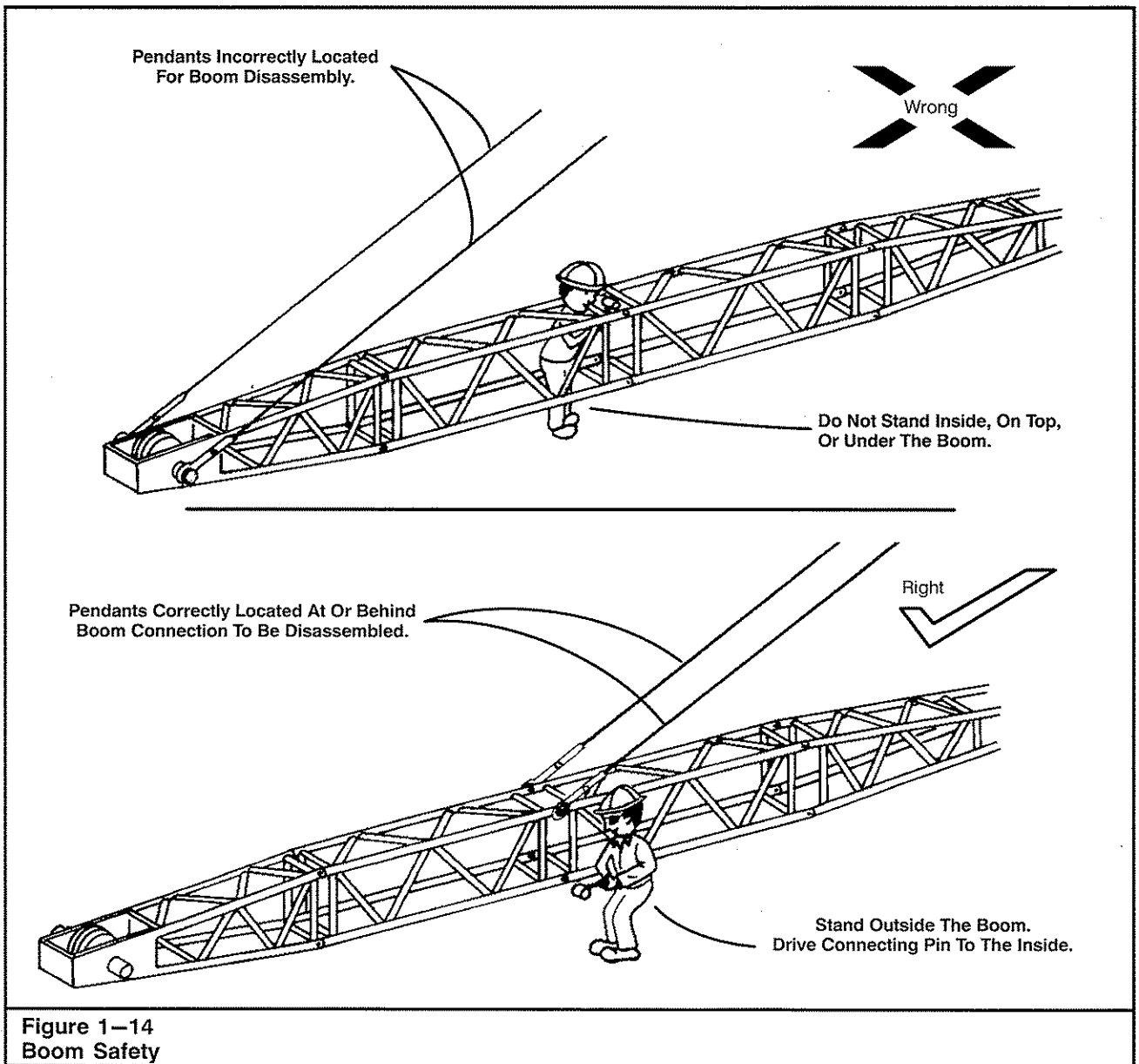

Boom Safety Instructions

Disassembly of any pin connected boom can be hazardous. Removing the wrong connecting pins or removing the connecting pins without first properly positioning pendants will cause the boom to fall. If you are under the boom when it falls, you may be killed. If there is any doubt in your mind about the boom disassembly procedure, block tightly under both ends of each boom section before removing any of the connecting pins.

The following points must be observed while performing any boom assembly or disassembly:

1. Read and understand the step by step instructions outlined in this Operator's Manual before attempting to assemble or disassemble the boom.
2. Do not stand inside, on top, or under the boom at any time while assembling or disassembling the boom.
3. Do not climb, stand, or walk on the boom. Use a ladder or similar device to reach necessary areas.
4. When removing or installing the boom section connecting pins, drive the pins from the outside of the boom toward the inside.

MODEL 108 HYLAB 5

BOOK No. 1028

LBCE SERIAL No. N8K2-2596

SCM SERIAL No. LS108-5117

CALIFORNIA

Proposition 65 Warning

Diesel engine exhaust and some of its constituents, and certain vehicle components contain or emit chemical known to the State of California to cause cancer, birth defects, and other reproductive harm.

CRANE SERIAL NUMBER

The crane serial number is on the Crane Rating Manual inside the operator's cab. The serial number should always be furnished when ordering parts for the crane or when corresponding with the Link-Belt Distributor or factory concerning the crane. Providing the serial number is the only way of ensuring the correct parts and/or information can be furnished.

In the event the serial number is not readable, a number is stamped on the upper revolving frame which can be used to help to identify the crane. This number is on the front face of the upper frame, between the boom foot mounting lugs.

Operator's Manual

Wire Rope Inspection

Any of the following are reasons to question wire rope safety:

1. More than one broken wire in any one strand should be cause for caution. Breaks that occur on the worn crowns of the outside wires usually indicate normal deterioration. Breaks that occur in the valleys between strands can indicate an abnormal condition, possibly fatigue and breakage of other wires that are not readily visible. One or more valley breaks should be cause for replacement.
2. Wire breaks generally occur in those portions of wire rope which pass over sheaves, wind onto drums, or receive mechanical abuse. Breaks that occur near end attachments are apt to result from fatiguing stresses concentrated in these localized sections. Breaks of the latter type should be cause for replacement of the wire rope or renewal of the attachment to eliminate the locally fatigued area. When running wire ropes over nylon sheaves, inspect the wire rope where it travels over the point sheaves. Inspect for a loss of diameter and then bend the wire rope to inspect the internal wires for breaks and wear.
3. Heavy wear or broken wires may occur in sections under equalizer sheaves or other sheaves where wire rope travel is limited or in contact with saddles. Particular care should be taken to inspect wire rope at these points. If wire rope wear is detected at these locations, the wear points can be shifted by removing a 20 ft (6.1m) section off the drum end. This may assist in extending the wire rope life.
4. Wire rope stretch is generally greatest during initial stages of operation when the strands are becoming adjusted and seated. This is accompanied by some reduction in wire rope diameter.
5. Time for wire rope replacement is indicated by the extent of abrasion, scrubbing, and peening on the outside wires, broken wires, evidence of pitting, or major corrosion, kink damage, or other mechanical abuse resulting in distortion of the wire rope structure.
6. Sheaves, guards, guides, drums, flanges, and other surfaces contacted by wire rope during operation should be examined at the time of inspections. Any condition harmful to the wire rope in use at the time should be corrected. This will assist in extending wire rope life. The same equipment, particularly sheave and drum grooves, should be inspected and placed in proper condition before a wire rope is installed.

Wire Rope Replacement

Any of the following are reasons for wire rope replacement:

1. In running wire ropes, six randomly distributed broken wires in one wire rope lay, or three broken wires in one strand in one wire rope lay.
For rotation resistant wire ropes, two randomly distributed broken wires in six wire rope diameters, or four randomly distributed broken wires in thirty wire rope diameters.
2. In pendants or standing wire ropes, evidence of more than two broken wires in one lay in sections beyond end connections or more than one broken wire in one wire rope lay at end connection.
3. One outer wire broken at the contact point with the core of the wire rope which has worked its way out of the wire rope structure and protrudes or loops out from the wire rope structure.
4. Abrasion, scrubbing, or peening causing loss of more than 1/3 the original diameter of individual wires.
5. Evidence of wire rope deterioration from corrosion.
6. Kinking, crushing, "bird caging", or other damage resulting in distortion of the wire rope structure.
7. Evidence of any heat damage.
8. Marked reduction in diameter indicates deterioration of the core resulting in lack of proper support for the load carrying strands. Major wire rope stretch or elongation may also be an indication of internal deterioration. Reduction from nominal diameter of more than:

Reduction of	Nominal Wire Rope Diameters
1/64" (.4mm)	up to and including 5/16" (8mm)
1/32" (.8mm)	over 5/16" (8mm) to 1/2" (13mm)
3/64" (1.2mm)	over 1/2" (13mm) to 3/4" (19mm)
1/16" (1.6mm)	over 3/4" (19mm) to 1-1/8" (29mm)
3/32" (2.4mm)	over 1-1/8" (29mm)

9. Noticeable rusting or development of broken wires in the area of connections.

Note: When replacing wire rope, the sheaves and grooves in drums should be checked for wear or damage and replaced if necessary. Damaged, worn, or undersized sheaves will damage the wire rope. On older equipment, remember that new wire rope is usually bigger in diameter than the worn wire rope it replaces. The sheave grooves may be worn to the smaller diameter of the old wire rope.

A new wire rope should be broken in by running it slowly through its working cycle for a short period under a light load. Refer to "Wire Rope Break-In" in this Section of this Operator's Manual.

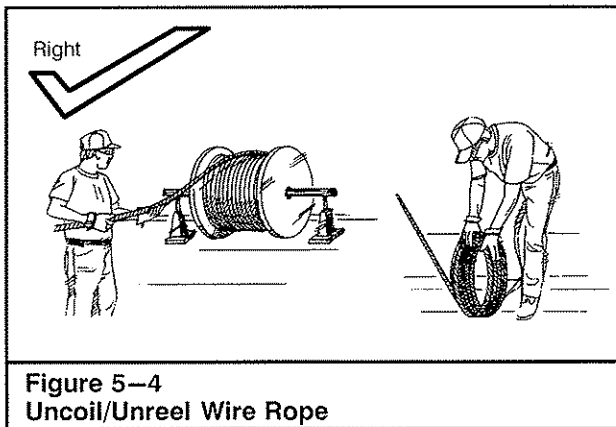

Wire Rope Installation

When installing wire rope, the primary concern is getting the wire rope onto the drum without trapping any twist that may have been induced during handling. Use the following procedure to install the wire rope on the crane.

Uncoiling/Unreeling Wire Rope

1. To avoid twists, unreel the entire wire rope on the ground in line with the boom head sheave and drum. Set the reel up horizontally so it can rotate as the wire rope is reeled off. Refer to Figure 5-4. Reel the wire rope off slowly, so the reel won't tend to "throw" the wire rope off. If the new wire rope cannot be laid out on the ground, further steps are necessary:
 - a. Mount the reel on a shaft through flange holes and on jack stands, making sure the reel is set to be unreeled over the top. Do not allow the reel to "free-wheel". Brake the reel by applying pressure to a flange. Do not apply braking pressure to the wire rope on the reel or pass wire rope between blocks of wood or other material.
2. Reeve the wire rope over the boom head sheave and anchor it to the drum.

Note: When replacing wire rope, the sheaves and grooves in drums should be checked for wear or damage and replaced if necessary. Damaged, worn, or undersized sheaves will damage the wire rope. Remember that new wire rope is usually larger in diameter than the worn wire rope it replaces. The sheave grooves may be worn to the smaller diameter of the old wire rope.

A new wire rope should be broken in by running it slowly through its working cycle for a short period under a light load. Refer to "Wire Rope Break-In" in this Section of this Operator's Manual.

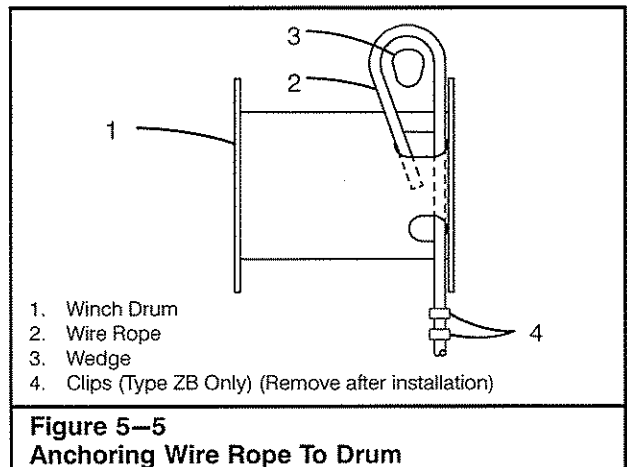

Anchoring Wire Rope To Drum

WARNING

Use the proper size wedge with a wire rope socket or drum. The use of an incorrect size wedge in a drum is dangerous as it may not hold. The size on the drum and wedge must correspond with the size of wire rope being used.

CAUTION

The ends of type ZB wire rope must be fuse welded. Failure to do so may cause the core to slip and/or the strands to loosen causing major wire rope damage.

If crane is equipped with type ZB wire rope, attach two clips (hose clamps are an effective and efficient alternative if traditional clips are not available) about 24 inches (609.6mm) from the end with a 3 inch (76.2mm) space between them. Refer to Figure 5-5. The seizings will prevent any looseness of the outer strands from traveling up the wire rope during installation. Insert the free end of the wire rope into the small opening of the anchor pocket. Loop the wire rope and push the free end about 3/4 of the way back through the pocket. Install the wedge, then pull the slack out of the wire rope. If using type ZB wire rope, remove the seizings after the wire rope is secured in the drum. Keep tension on the wire rope to prevent the wire rope from becoming slack and forming loops or kinks and also to allow uniform winding on the drum. It is important that original wire rope lay is maintained at all times.

Use the correct size wedge for the drum and wire rope being used. Refer to Figure 5-11 for correct identification.

Operator's Manual

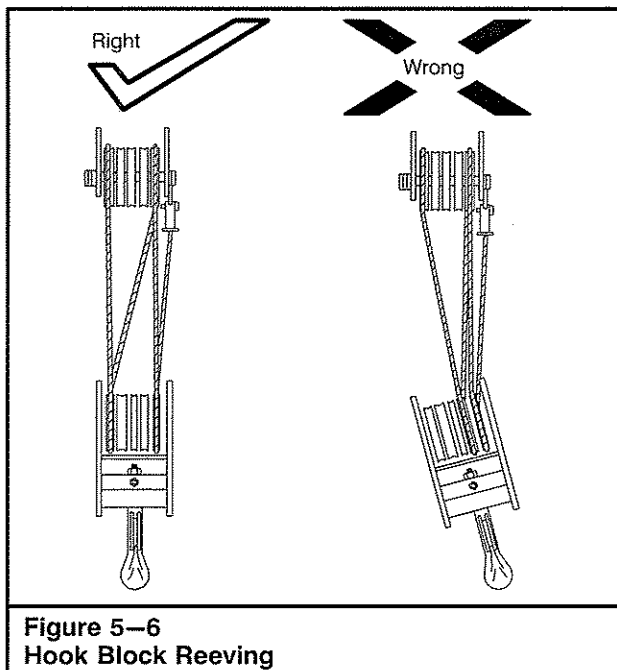

Winding Wire Rope On Drum

Proper winding of the first layer of wire rope on a multiple wrap drum is important. If the first layer is properly wound, succeeding layers will be easier to control. This is especially important on ungrooved drums. When starting new wire rope on such drums, drive each wrap of the first layer lightly with a wooden mallet so each wrap barely contacts the preceding one. Keep tension on the wire rope to prevent the wire rope from becoming slack and forming loops or kinks and also to allow uniform winding on the drum. It is important that original wire rope lay is maintained at all times.

It's important to apply a tensioning load while spooling the wire rope on the drum. (If not, the lower layers may be loose enough that the upper layers become wedged into the lower layers under load, which can cause major damage to the wire rope.) The tensioning load should range from 1 to 2% of the wire rope's nominal strength.

Causes Of Irregularly Wound Wire Rope

1. Irregular winding of the first layer of wire rope on the drum. Never leave any gap between the wire ropes.
2. Incorrect approach. A transition from one layer to the next must be made after the layer comes into contact with the drum flange.

3. Wire rope should be wound on a drum with sufficient tension. Lifting a heavy load with a loosely wound wire rope will cause irregular winding of the wire rope on the drum or breaking of wire rope wires.
4. If the crane is provided with a guide sheave on the front of a drum, smooth movement of the guide sheave is essential to prevent irregular winding of the wire rope. Check the guide sheave for smooth rotation and lubrication.

Wire Rope Reeving



WARNING

To avoid personal injury, do not climb, stand, or walk on the boom or jib. Use a ladder or similar device to reach necessary areas when reeving the crane.

Only if certain criteria are met may a swivel hook ball be used with rotation resistant wire rope. Refer to "Hook Ball Usage With Rotation Resistant Wire Rope" in this Section of this Operator's Manual.

The crane can use from one to eight parts of line when reeving the main winch, depending on the lift being made. When reeving the main winch, odd parts of line dead end at the hook block and even parts dead end at the boom peak. Even parts of line will resist block rotation better than odd parts of line. It may be advantageous to use even parts of line. The jib may be reeved with two parts of line for better line control, but can lift no more than with a single part of line due to structural capacities of the jib. Figure 5-18 illustrates the proper reeving for various parts of line. The reeving patterns shown must be used at all times. To determine how many parts of line to use for a particular lift, check the Wire Rope Capacity Chart in the Crane Rating Manual. Figure 5-19 gives the proper reeving for the boom hoist wire rope.

Note: Wire rope guards must always be used during operations. They must be pinned in place to prevent wire rope from jumping off the sheaves. Deflector rollers must also be used to prevent frictional damage to boom sections.

Hook blocks should be reeved correctly so they hang straight and do not cause unnecessary wear on the wire rope and sheaves. Refer to Figure 5-6.

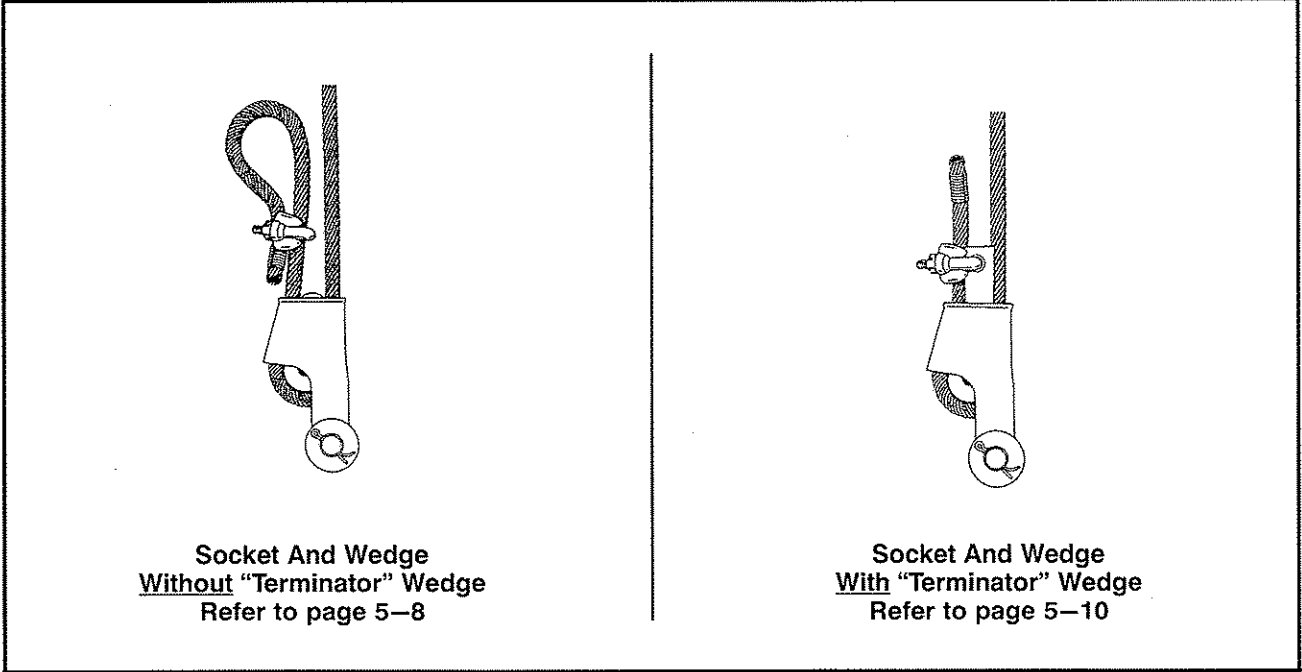

Figure 5-7
Sockets And Wedges

Sockets And Wedges

This crane may be equipped with two styles of sockets and wedges. One style socket uses a "terminator" wedge and the other does not. The wedges for each style are installed differently. Refer to Figure 5-7 to determine which style your crane has and where to find the appropriate information for use and installation.

 **WARNING**

Do not interchange sockets and wedges. Loads may slip or fall if socket and wedge are not properly matched. Use a "terminator" wedge with a utility socket for a "terminator" wedge and a non-"terminator" wedge with a non-"terminator" ready socket.

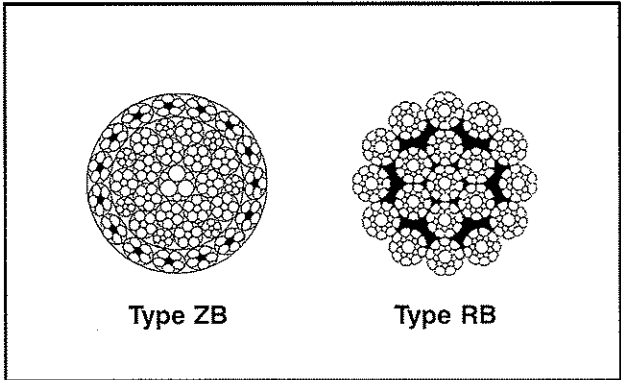

Figure 5-8
Wire Rope Identification

Operator's Manual

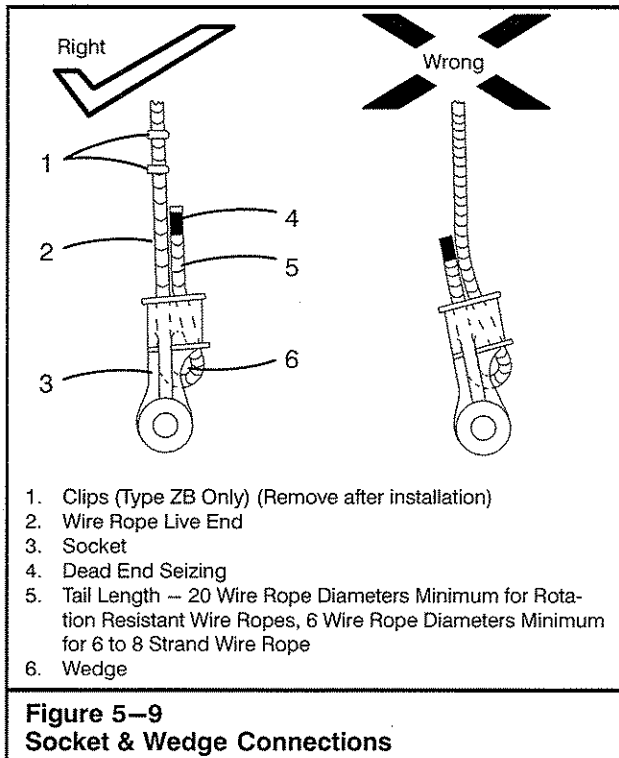

Figure 5-9
Socket & Wedge Connections

Socket & Wedge Assembly – Without Extended Wedge



WARNING

Use the proper size wedge with a wire rope socket or drum. The use of an incorrect size, type, or brand of wedge in a socket or drum is dangerous as it may not hold. Wedges and sockets shipped from the factory are stamped with size and type identification. A drum or socket may be stamped for two or more sizes of wire rope and a wedge for one or two. The size on the drum, socket, and wedge must correspond with the size of wire rope being used.



WARNING

Do not interchange sockets and wedges. Loads may slip or fall if socket and wedge are not properly matched. Use a “terminator” wedge with a utility socket for a “terminator” wedge and a non-“terminator” wedge with a non-“terminator” ready socket.

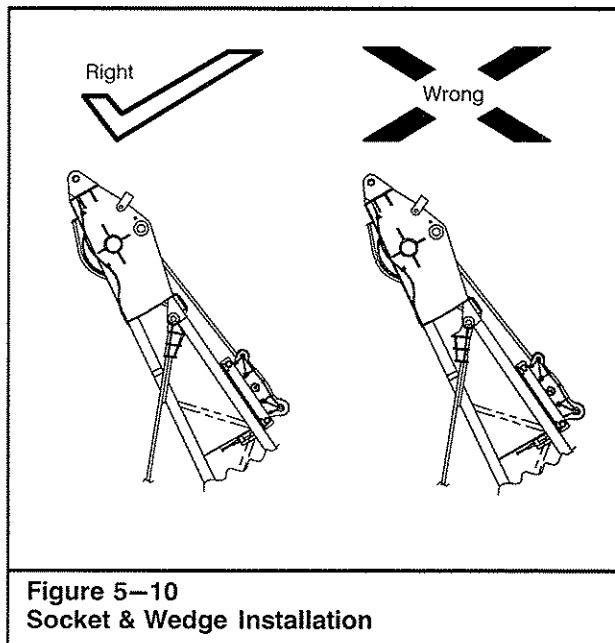

Figure 5-10
Socket & Wedge Installation

The correct and incorrect methods of attaching a wedge and socket to wire rope are shown in Figure 5-9. The dead end of the wire rope must always be on the sloped portion of the socket. The load line must be in a straight line pull with the eye of the socket. If the wire rope is installed wrong as shown in Figure 5-9, a permanent set will develop at the point where the wire rope enters the socket. This permanent set will weaken the wire rope and accelerate wear at this point.

Wedges and sockets shipped from the factory are stamped with size and type or pair identification. Refer to Figure 5-11. A drum, socket, or wedge may be stamped for two or more sizes of wire rope. The size on the drum, socket, and wedge must correspond with the size of wire rope being used. The part number may also be stamped on the socket and wedge. Refer to the Parts Manual for confirmation. If there is any doubt as to the mating of the socket and wedge, contact your Link-Belt Distributor.

Note: The sockets and wedges in the boom hoist system are metric sizes. Ensure that English and metric sizes are not mixed.

Before installing type ZB wire rope into a socket or wedge, attach two clips (hose clamps are an effective and efficient alternative if traditional clips are not available) approximately 3-4 feet (0.9-1.2m) from the end with a 3 inch (76.2mm) space between them. Refer to Figure 5-9. The dead end must also be seized and a minimum tail length of 20 wire rope diameters [15” (38cm) for 3/4” (19mm) wire rope] is required. The clips will help prevent core slippage and any looseness

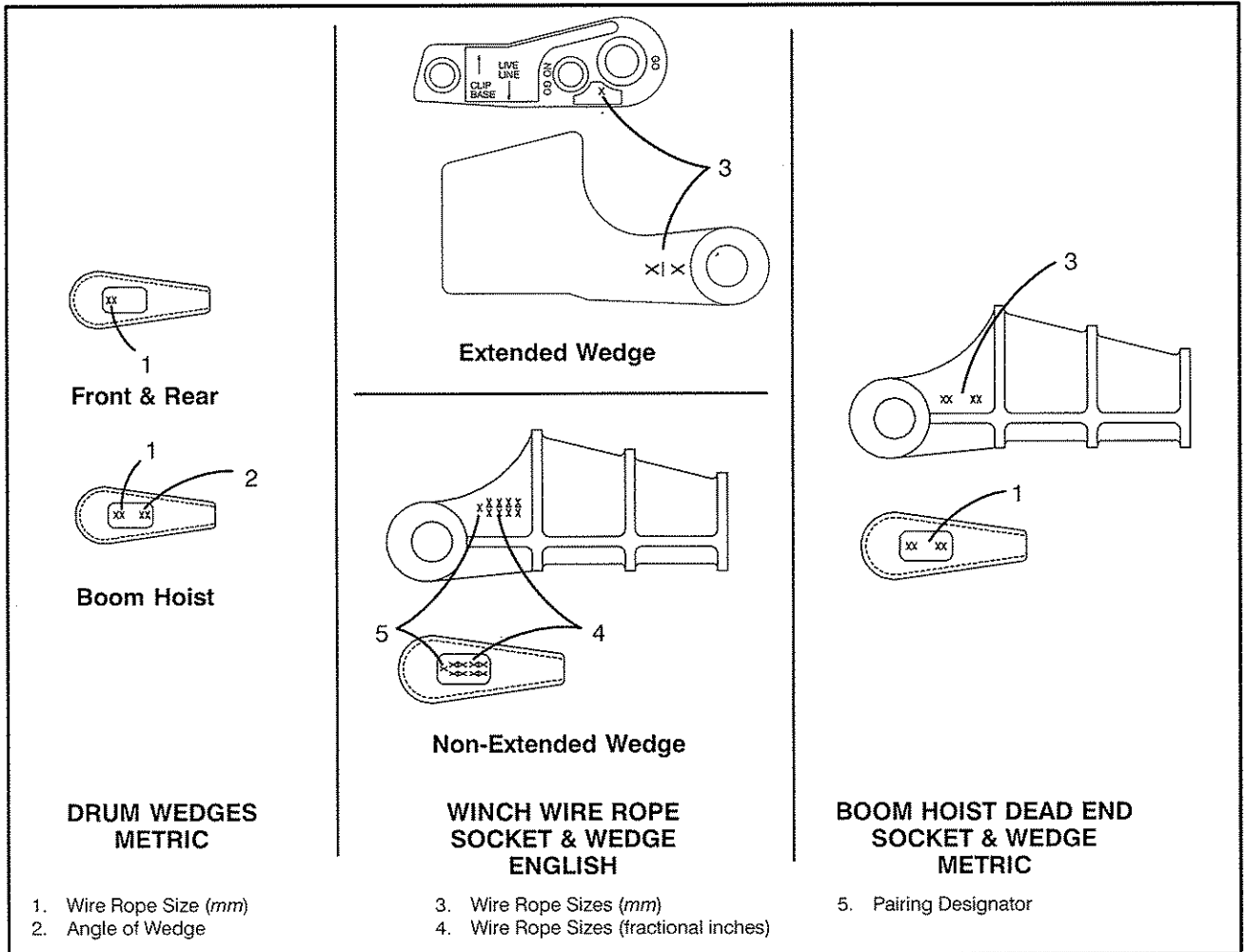

Figure 5-11
Examples Of Typical Socket & Wedge Identifiers

of the outer strands from traveling up the wire rope during installation while still allowing the wire rope strands to be free to adjust. If using type ZB wire rope, remove clips from the live end after wire rope is securely installed into the socket.

Note: Refer to Figure 5-8 to identify which type of wire rope is installed on the crane.

When anchoring the socket to the boom head, ensure that the flat face is facing out as shown in Figure 5-10. If socket is not installed correctly, structural damage to the boom head may occur.

It is recommended that annually, the socket and wedge connection be removed, that portion of wire rope be removed, and a new connection be installed.

CAUTION

The ends of type ZB wire rope must be fuse welded and the tail length of the dead end must be a minimum of 20 wire rope diameters [15" (38cm) for 3/4" (19mm) wire rope]. Failure to do the above may cause the core to slip and/or the strands to loosen causing major wire rope damage.



WARNING

Wire rope can spin uncontrollably when removing wire rope dead end pins. Serious personal injury can result if wire rope spin is not properly controlled. Take the appropriate safety precautions to control the wire rope and wear the appropriate safety equipment before removing wire rope dead end pins.

Operator's Manual

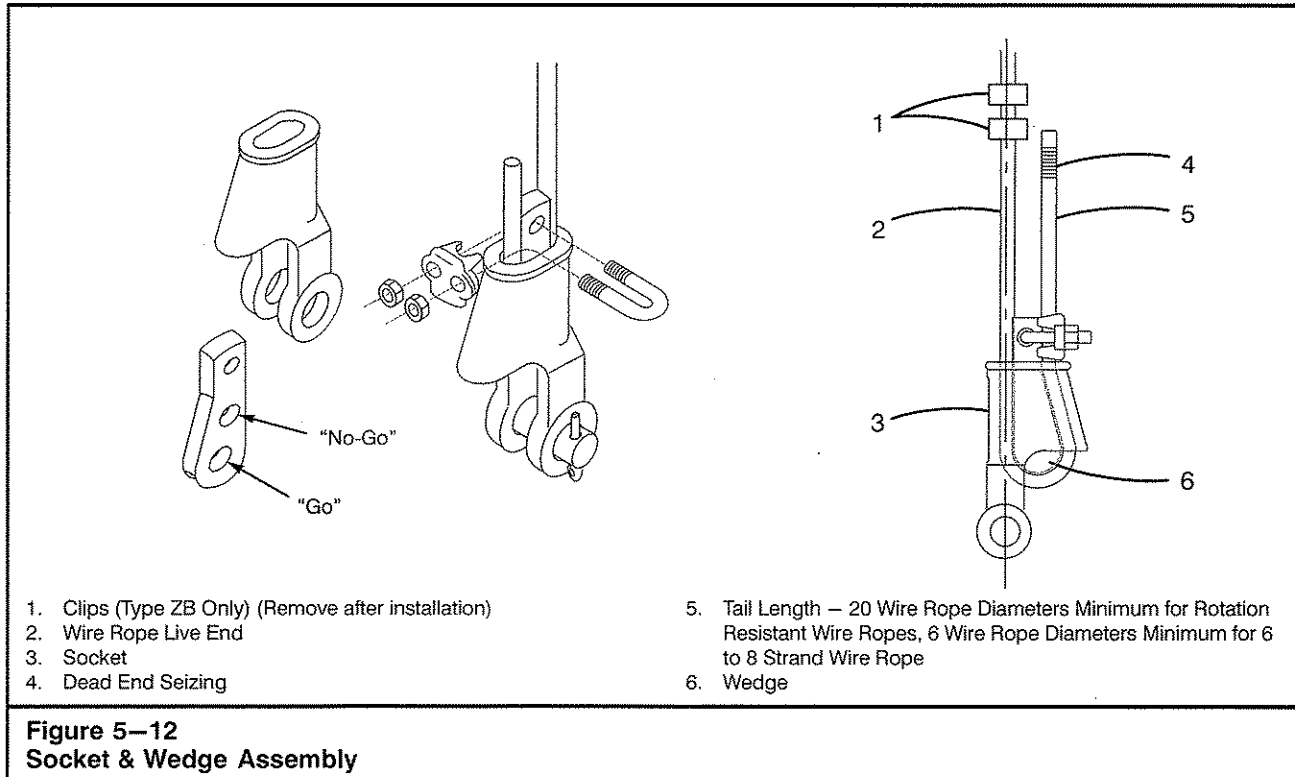

Socket & Wedge Assembly – With Extended Wedge



WARNING

Use the proper size wedge with a wire rope socket or drum. The use of an incorrect size, type, or brand of wedge in a socket or drum is dangerous as it may not hold. Wedges and sockets shipped from the factory are stamped with size and type identification. A drum or socket may be stamped for two or more sizes of wire rope and a wedge for one or two. The size on the drum, socket, and wedge must correspond with the size of wire rope being used.



WARNING

Do not interchange sockets and wedges. Loads may slip or fall if socket and wedge are not properly matched. Use a "terminator" wedge with a utility socket for a "terminator" wedge and a non-"terminator" wedge with a non-"terminator" ready socket.

The correct and incorrect methods of attaching a wedge and socket to wire rope are shown in Figure 5-13 and Figure 5-12. The dead end of the wire rope must always be on the sloped portion of the socket. The load line must be in a straight line pull with the eye of the socket. If the wire rope is installed wrong as shown in Figure 5-13, a permanent set will develop at the point where the wire rope enters the socket. This permanent set will weaken the wire rope and accelerate wear at this point.

Wedges and sockets shipped from the factory are stamped with size and type or pair identification. Refer to Figure 5-11. A drum, socket, or wedge may be stamped for two or more sizes of wire rope. The size on the drum, socket, and wedge must correspond with the size of wire rope being used. The wedge also has a "go"/"no-go" feature cast into the wedge to assist in determining the proper size wire rope that can be used with that particular socket and wedge. Refer to Figure 5-12. The proper size wire rope is determined when: 1) the wire rope shall pass through the "go" hole in the wedge, and 2) the wire rope shall not pass through the "no-go" hole in the wedge. The part number may also be stamped on the socket and wedge. Refer to the Parts Manual for confirmation. If there is any doubt as to the mating of the socket and wedge, contact your Link-Belt Distributor.

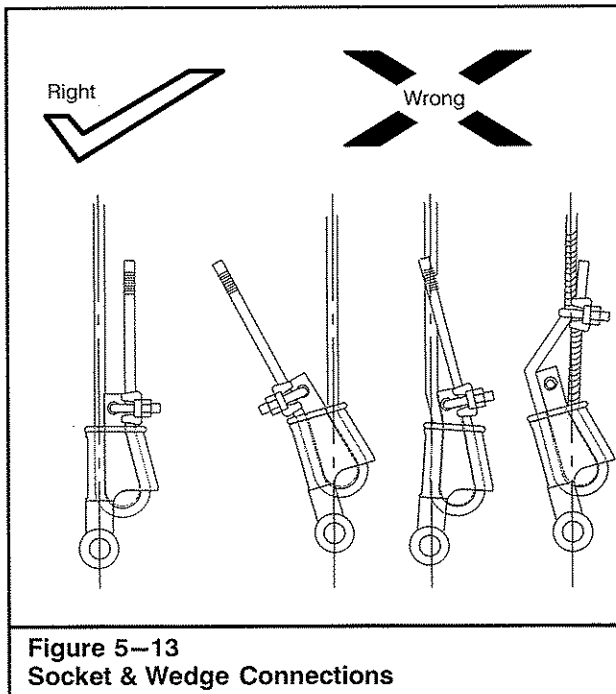

Figure 5-13
Socket & Wedge Connections

Before installing type ZB wire rope into a socket or wedge, attach two clips (hose clamps are an effective and efficient alternative if traditional clips are not available) approximately 3-4 feet (0.9-1.2m) from the end with a 3 inch (76.2mm) space between them. Refer to Figure 5-12. The dead end must also be seized and a minimum tail length of 20 wire rope diameters [15" (38cm) for 3/4" (19mm) wire rope] is required. The clips will help prevent core slippage and any looseness of the outer strands from traveling up the wire rope during installation while still allowing the wire rope strands to be free to adjust. If using type ZB wire rope, remove clips from the live end after wire rope is securely installed into the socket.

Note: Refer to Figure 5-8 to identify which type of wire rope is installed on the crane.

CAUTION

The ends of type ZB wire rope must be fuse welded and the tail length of the dead end must be a minimum of 20 wire rope diameters [15" (38cm) for 3/4" (19mm) wire rope]. Failure to do the above may cause the core to slip and/or the strands to loosen causing major wire rope damage.

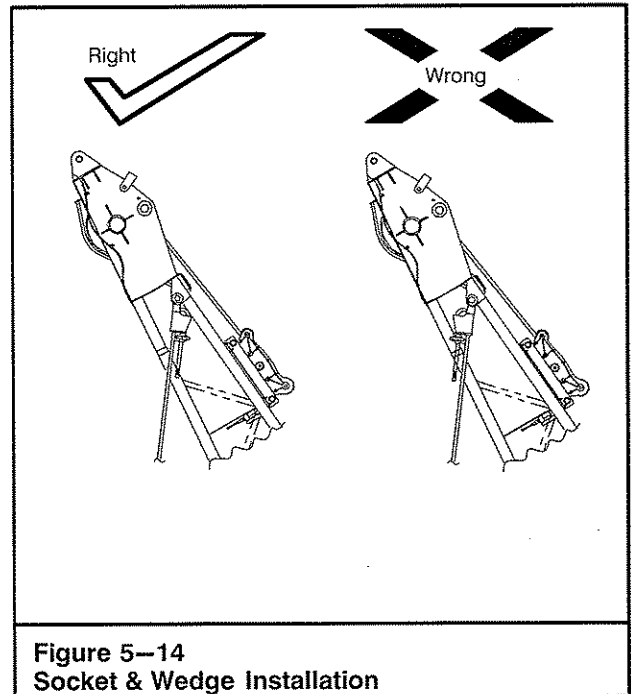

Figure 5-14
Socket & Wedge Installation

Use a hammer to seat the wedge and wire rope as deep into the socket as possible before applying first load. Lift the first load a few inches (cm) from the ground to fully seat the wedge and wire rope in the socket. This load should be of equal or greater weight than loads expected in use.

Secure the dead end section of the wire rope by installing the clip through the wedge as shown in Figure 5-12. Tighten the nuts on the clip to the recommended torque as shown on the table in Figure 5-17.

When anchoring the socket to the boom head, ensure that the flat face is facing out as shown in Figure 5-14. If socket is not installed correctly, structural damage to the boom head may occur.

It is recommended that annually, the socket and wedge connection be removed, that portion of wire rope be removed, and a new connection be installed.



WARNING

Wire rope can spin uncontrollably when removing wire rope dead end pins. Serious personal injury can result if wire rope spin is not properly controlled. Take the appropriate safety precautions to control the wire rope and wear the appropriate safety equipment before removing wire rope dead end pins.

Operator's Manual

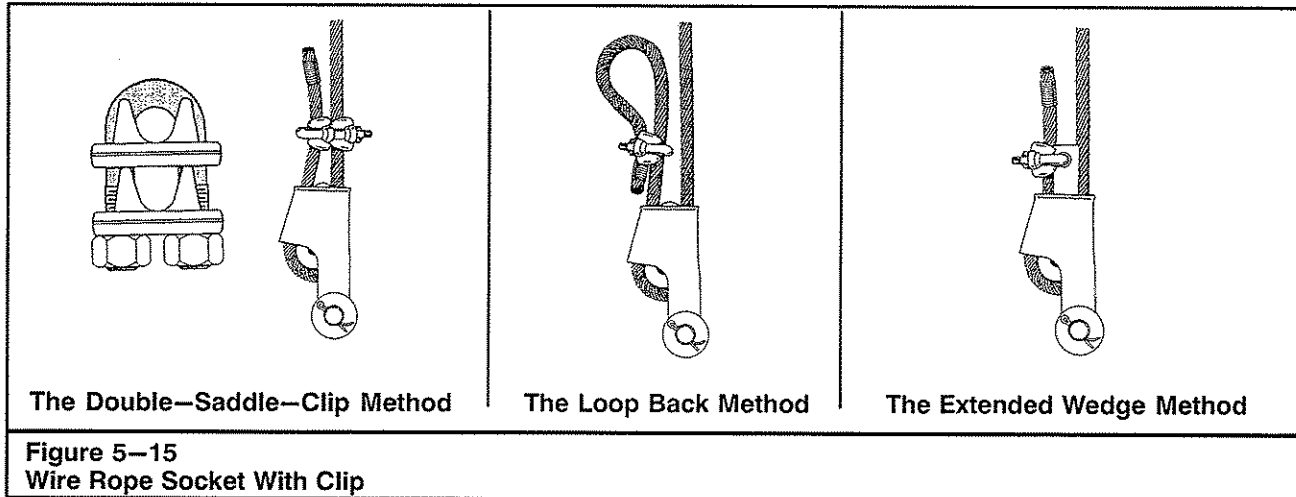

Wire Rope Sockets With Clips

Some codes require the use of a wire rope clip in conjunction with a socket and wedge connection. Figure 5-15 illustrates some typical methods of clip installation with sockets. In some cases, particularly in wrecking ball work, there is a chance that the wedge can loosen, releasing the socket from the wire rope. This could be caused by the banging action and alternate loading and unloading of the wire rope that occurs during this type work.

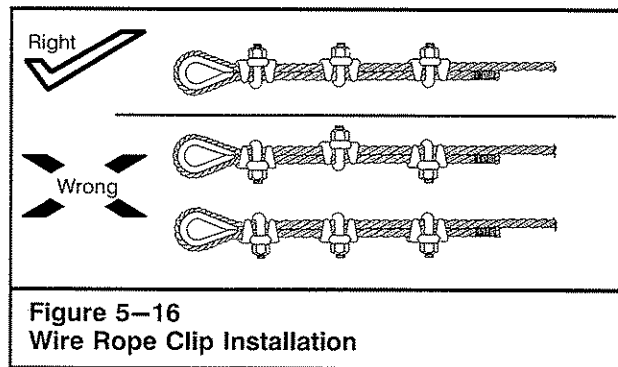

WARNING

The point at which a wire rope enters an end attachment (clips, wedge, or socket) must be thoroughly examined during regular inspections. This is a location where fatigue of wires occurs due to the restriction of the wire rope in the end attachment. Any broken wires at this point is reason for cutting off the affected area and making a new end attachment, or for replacing the entire wire rope.

The use of wire rope clips with a socket and wedge connection can weaken the connection if done improperly. Do not attach the dead end of the wire rope to the live side with the clip as this will weaken the connection. The clip may ultimately take the load and may deform or break the wire rope.

If using the loop back method, the loop formed must not be allowed to enter the wedge, or the connection will be weakened. The tail length of the dead end must be a minimum of 20 wire rope diameters.

Wire Rope Clip Installation

The correct method of installing u-bolt wire rope clips is shown in Figure 5-16. The u-bolt must always be over the short end of the wire rope and the base must always contact the long end.

Clips should NOT be staggered, that is u-bolt of one clip over short end and u-bolt of next clip over long end. This practice will not only distort the wire rope excessively, but will prevent maximum strength of this type fastening. Placing all clips with the u-bolt over the long end of the wire rope will damage strands and result in an unsafe condition.

The distance between clips should be not less than six times the wire rope diameter. In relation to size of wire rope, the minimum number of clips recommended for safe connections is given in Figure 5-17.

CAUTION

Apply the initial load and retighten nuts to the recommended torque. Wire rope can stretch and shrink in diameter when loads are applied. Inspect periodically and retighten as required.

Operator's Manual

Recommended Wire Rope Clips						
Clip Size		Minimum No. of Clips	Amount of Wire Rope To Turn Back*		Torque	
Inches	mm		Inches	mm	Ft Lb	Nm
1/8	3.2	2	3 1/4	82.5	—	—
3/16	4.7	2	3 3/4	95.2	—	—
1/4	6.3	2	4 3/4	120.6	15	20.0
5/16	7.9	2	5 1/4	133.3	30	40.7
3/8	9.5	2	6 1/2	165.1	45	60.1
7/16	11.1	2	7	177.8	65	86.8
1/2	12.7	3	11 1/2	292.1	65	86.8
9/16	14.3	3	12	304.8	95	126.9
5/8	15.9	3	12	304.8	95	126.9
3/4	19.0	4	18	457.2	130	173.6
7/8	22.2	4	19	482.6	225	300.6
1	25.4	5	26	660.4	225	300.6
1-1/8	28.6	6	34	863.6	225	300.6
1-1/4	31.7	6	37	939.8	360	480.9
1-3/8	34.9	7	44	1117.6	360	480.9
1-1/2	39.1	7	48	1219.2	360	480.9
1-5/8	41.3	7	51	1295.4	430	574.4
1-3/4	44.5	7	53	1346.2	590	788.1
2	50.8	8	71	1803.4	750	1001.9
2-1/4	57.2	8	73	1854.2	750	1001.9
2-1/2	63.5	9	84	2133.6	750	1001.9
2-3/4	69.9	10	100	2540.0	750	1001.9
3	76.2	10	106	2692.4	1200	1603.0

*If a greater number of clips are used than shown in this table, the amount of wire rope turn back should be increased proportionally.

Figure 5-17
Recommended Wire Rope Clips

Wire Rope Break-In

After the wire rope has been installed and the ends secured in the correct manner, the new wire rope must be run through a break-in period. This allows the component parts of the new wire rope to gradually adjust itself to actual operating conditions.

1. Properly park the crane on a firm, level surface. Fully extend the side frames. Swing the upper over the end of the carrier and engage the swing lock.
2. Fully raise the boom. Attach a light load at the hook and raise it a few inches (*cm*) off the ground. Allow to stand for several minutes.

3. Run the wire rope through a cycle of operation at very slow speeds. During this trial operation, a very close watch should be kept on all working parts—sheaves, drums, rollers, etc. to make certain that the wire rope runs freely, and without any possible obstructions as it makes its way through the system.

Note: Run these loads with reeving that places the loads on the block with all wire rope off the drum except the last three wraps. If this is not possible, alternate methods must be used to assure proper tensioning of the wire rope on the drum.

4. If no problems appear in running the wire rope, repeat procedure with an increased load.

Operator's Manual

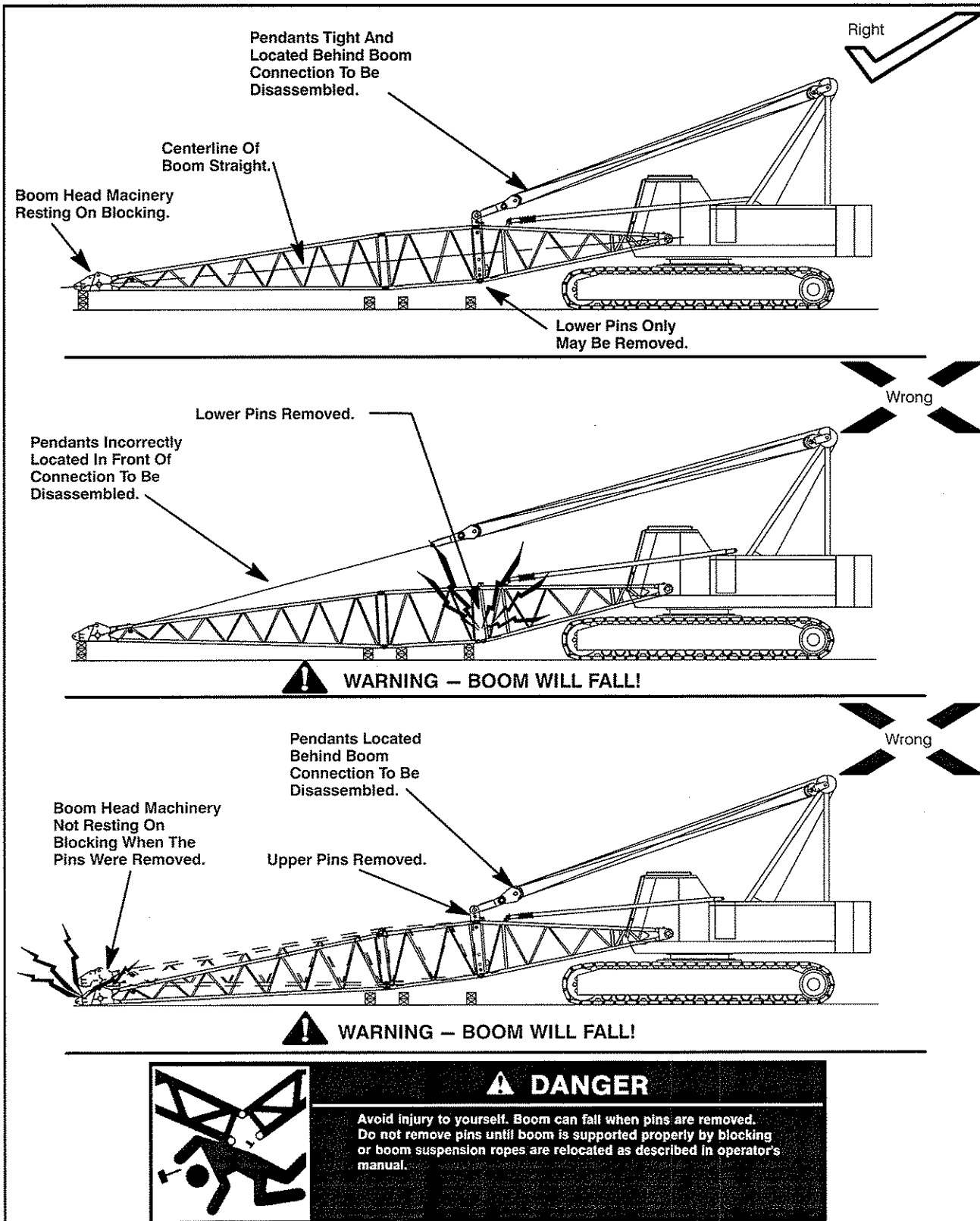

Figure 1-15
Pin Connected Boom Disassembly

Operator's Manual

Cutting Wire Rope

CAUTION

The ends of type ZB wire rope must be fuse welded. Failure to do so may cause the core to slip and/or the strands to loosen causing major wire rope damage.

When wire rope is to be cut, seizing should be placed on each side of the point where the wire rope is to be cut, to keep the strands in place. On preformed wire rope, one seizing on each side of the cut is enough. On non-preformed wire rope less than 7/8 in (23mm) diameter, two seizings are recommended. On non-preformed wire rope over 7/8 in (23mm) diameter, three seizings are recommended. Wire or strand must be used to seize non-preformed wire rope. Wire, strand, or heavy tape may be used to seize preformed wire rope.

Three Basic methods of cutting wire rope are recommended:

1. Abrasive cutting tools.
2. Shearing tools. (Wire cutters on small wire rope, a wire rope cutter, and hammer for larger wire ropes.)
3. Oxy/Acetylene fuel torch. A torch can be used to cut type ZB wire rope only. The heat will fuse weld the end, which is OK for type ZB, but not for other types which are not to be fuse welded.

Rotation Resistant Wire Rope

The rotation resistant characteristic is achieved by laying the outer strands around an independent wire rope that is wound in the opposite direction. When the wire rope has tension on it, opposing rotational forces are created between the core and outer strands. If a swivel hook ball is utilized with rotation resistant wire rope, the wire rope is allowed to twist. The outer strands unwind and get longer while the inner core is forced to rotate in the same direction and shortens in length. As a result of this treatment, the inner core sees a disproportionately greater load, and core damage may occur due to shock loading

or overloading. A rotating load on an unrestrained, non-swivel hook ball without a tagline, also affects the internal loading of the wire rope in this manner. This practice, or any other which allows the wire rope to rotate while in service, leads to unbalanced loading between the inner and outer layer of strands, which may result in core failure. Wire rope manufacturer's testing has shown that rotation resistant wire rope utilized with a swivel hook ball has reduced the breaking strength by as much as 50% if excessive rotation occurs.

Hook Ball Usage With Rotation Resistant Wire Rope

Non-Swivel Usage

A non-swivel hook ball in conjunction with a tagline or other device to control load spin should be used when the crane is equipped with rotation resistant wire rope. This is to avoid unrestrained rotation of the wire rope.

Swivel Usage

A swivel hook ball can be used with rotation resistant wire rope if:

1. The wire rope is not shock loaded or overloaded.
2. Wire rope working strength is reduced to maintain original design safety factors.
3. The wire rope is inspected frequently as outlined in this Section of this Operator's Manual.

Wire Rope Inspection

Marked reduction in diameter indicates deterioration of the core resulting in lack of proper support for the load carrying strands. Major wire rope stretch or elongation may also be an indication of internal deterioration. Major concerns and replacement recommendations include:

1. Loss of wire rope diameter (in excess of those listed in the table in the "Wire Rope Replacement" in this Section of this Operator's Manual), abnormal lengthening of wire rope lay, or protrusion of wires between the outer strands.
2. Two randomly distributed broken wires in 6 wire rope diameters, or 4 randomly distributed broken wires in 30 wire rope diameters.

Operator's Manual

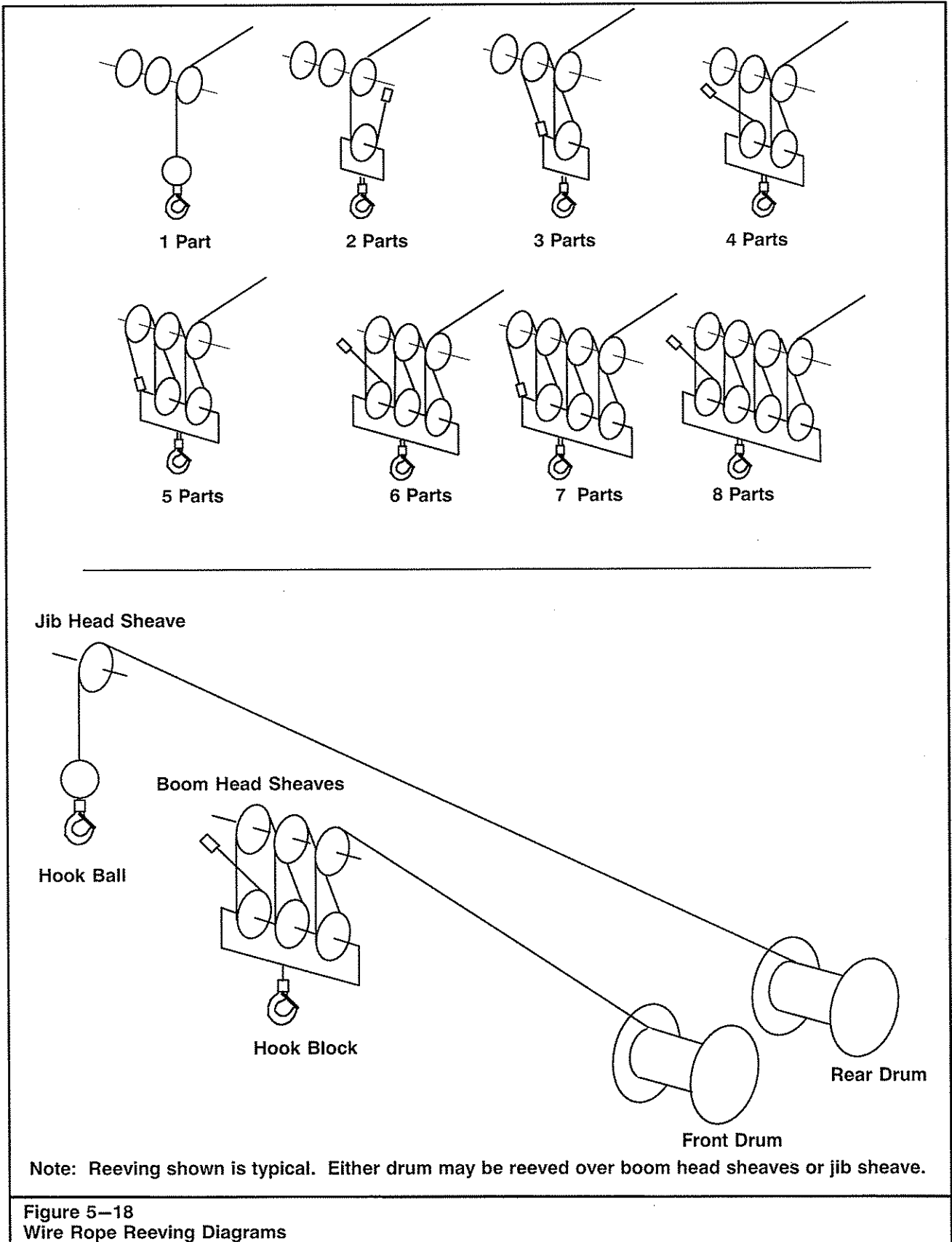

Operator's Manual

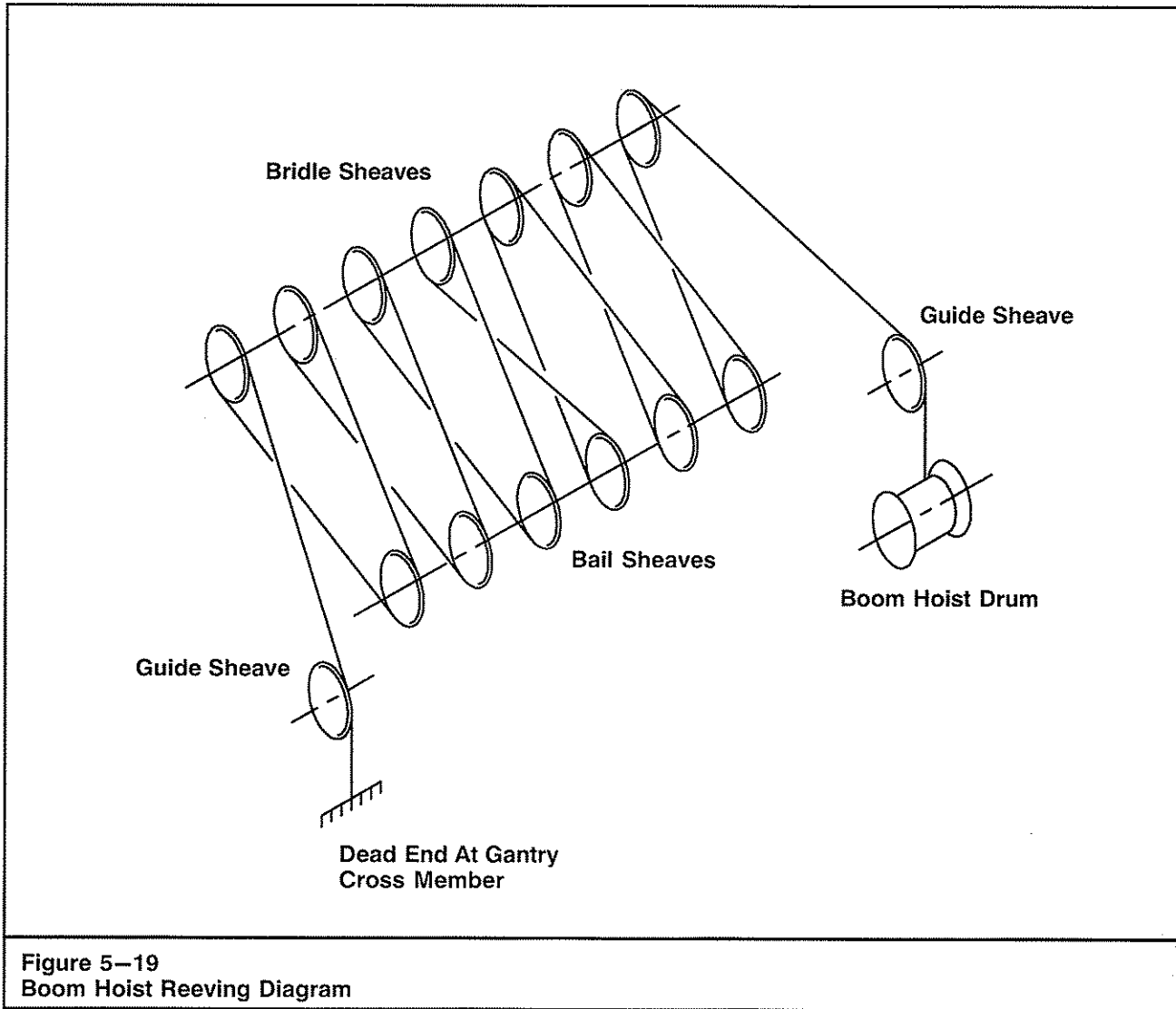

Crane Specifications

The following specifications are general in nature and are used for reference purposes only. Depending upon the vintage of the crane, some features may no longer be available. Standard and optional features may vary from crane to crane. Contact the Link-Belt Distributor or factory to verify the specific information if required.

Dimensions

General Dimensions	English	Metric
Basic Boom	40 ft	12.19m
Minimum Load Radius	8.6 ft	2.62m
Maximum Boom Angle	82°	82°
Track Shoe Width	36 in	914mm

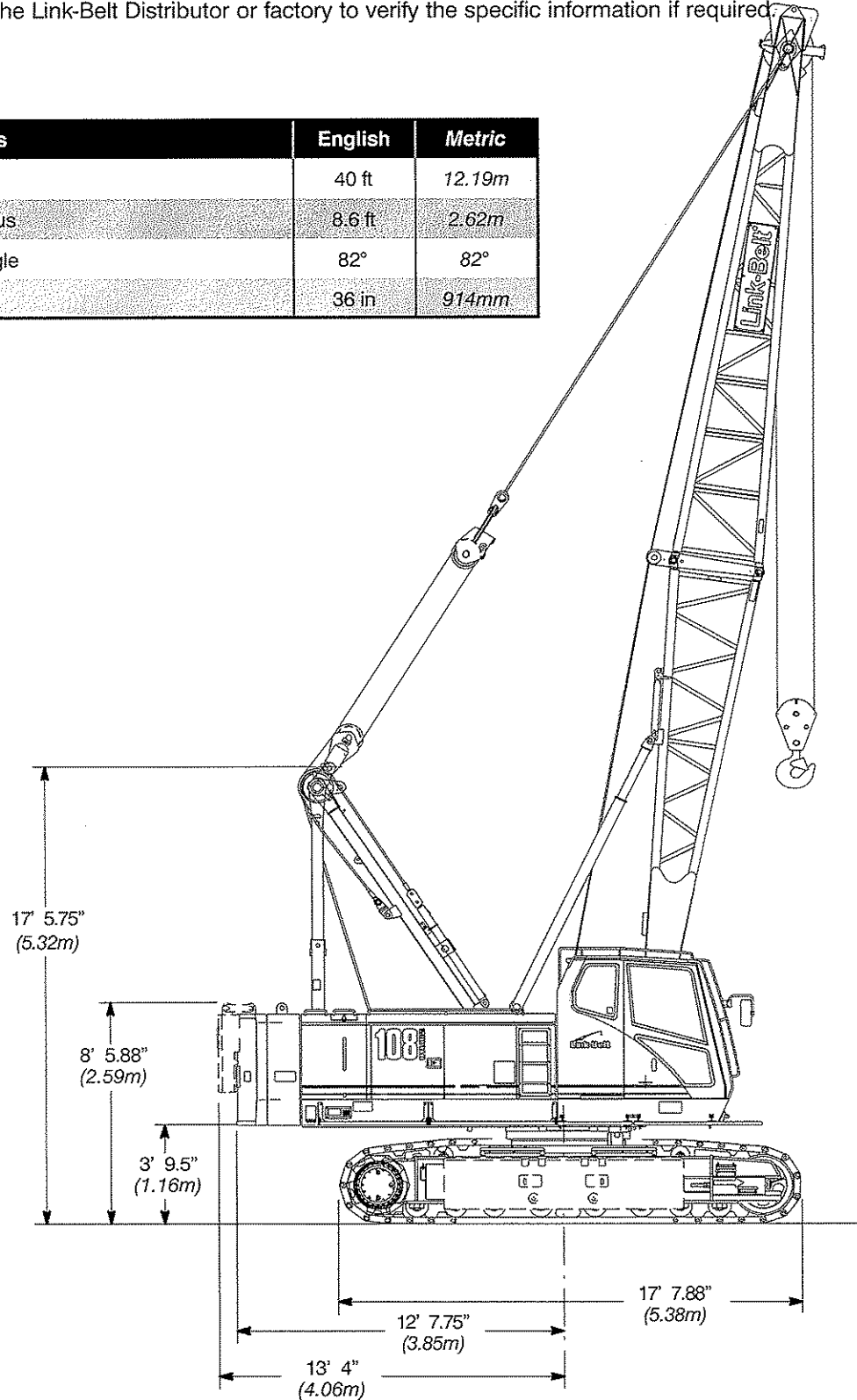

Operator's Manual

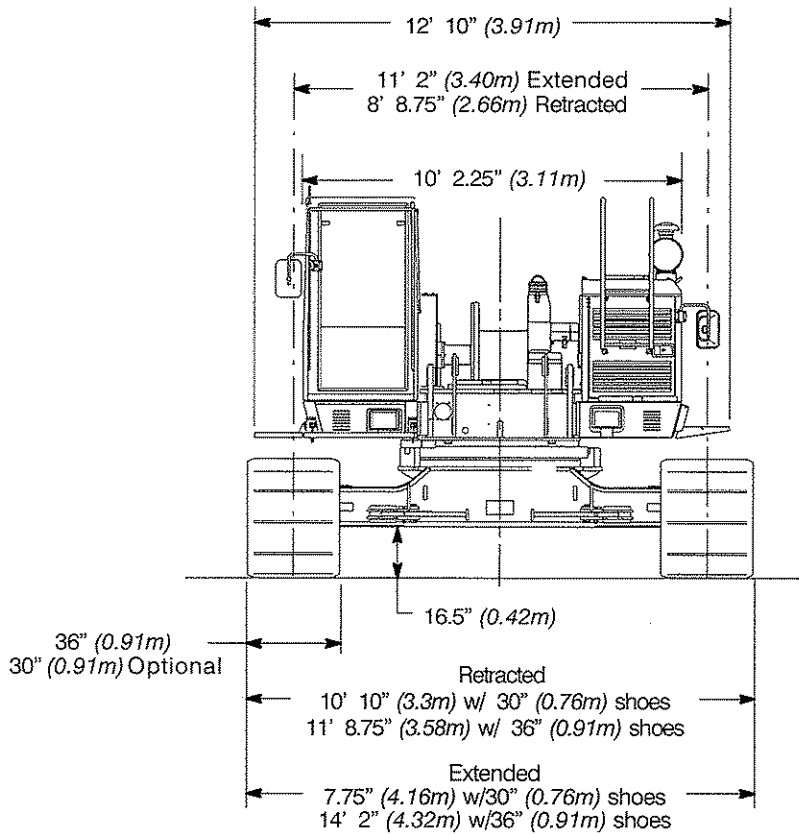
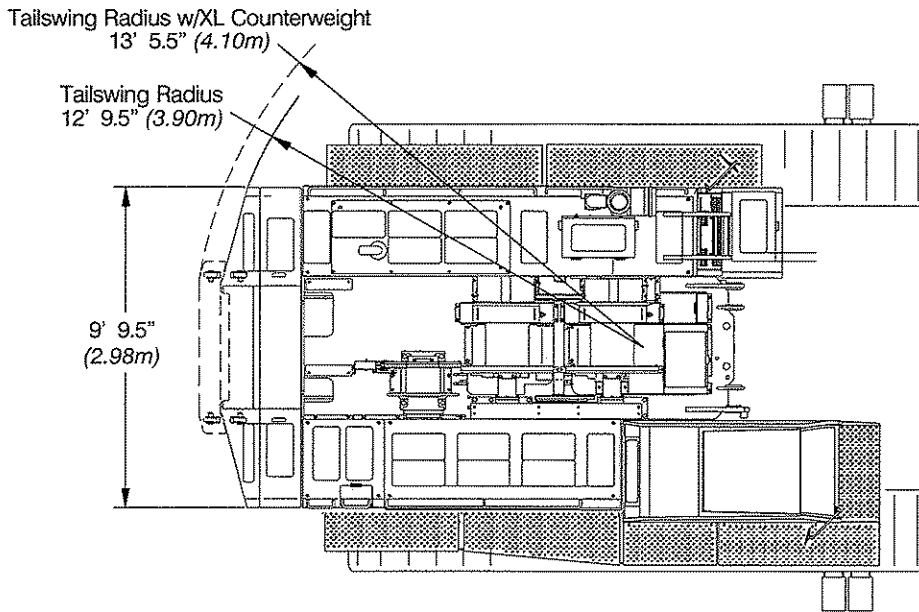

Operator's Manual

Upper Structure

Frame

All welded and precision machined surfaces.

Turntable Bearing

- Inner race with internal swing gear is bolted to lower frame
- Outer race bolted to upper frame

Engine

Engine

Full pressure lubrication, oil filter, air cleaner, hour meter, throttle, and electric control shutdown.

Isuzu BB-6BG1		Isuzu AH-4HK1	
Number of cylinders	6	Number of cylinders	4
Bore and stroke	4.13 in x 4.92 in (105 x 125mm)	Bore and stroke	4.53 in x 4.92 in (115 x 125mm)
Piston displacement	396 in ³ (6.5L)	Piston displacement	317 in ³ (5.2L)
Engine rpm at full load speed	2,200 rpm	Engine rpm at full load speed	2,100 rpm
Hi-idle rpm	2,420 rpm	Hi-idle rpm	2,100 rpm
Gross engine hp	170 hp (127kw)	Gross engine hp	200 hp (148kw)
Peak torque	396 ft lb (538joule) @ 1,800 rpm	Peak torque	507 ft lb (688joule) @ 1,500 rpm
Electrical system	24 volt	Electrical system	24 volt
Fuel tank capacity	77 gal (291.5L)	Fuel tank capacity	77 gal (291.5L)
Batteries	2-12 volt	Batteries	2-12 volt
Approximate fuel consumption	gal/hr (L/hr)	Approximate fuel consumption	gal/hr (L/hr)
100% hp	8.94 (33.84)	100% hp	10.42 (39.44)
75% hp	6.70 (25.36)	75% hp	8.20 (31.04)
50% hp	4.47 (16.92)	50% hp	6.06 (22.94)
25% hp	2.23 (8.44)	25% hp	3.03 (11.50)

Fuel Tank

Equipped with fuel sight level gauges, flame arrester, and self-closing cap with locking eye for padlock.

Hydraulic System

Hydraulic Pumps

The pump arrangement is designed to provide hydraulically powered functions allowing positive, precise control with independent or simultaneous operation of all crane functions.

- Two variable displacement pumps operating at 4,270 psi (300kg/cm²) and 64 gal/min (243L/min) powers load hoist drums, boom hoist drum, optional third drum, and travel.
- One fixed displacement gear type pump operating at 3,000 psi (210kg/cm²) and 29 gal/min (111L/min) powers the swing motor and retract cylinders.

- One fixed displacement gear type pump operating at 1,200 psi (85kg/cm²) and 6.6 gal/min (25L/min) powers the remote control valves and counterweight lifting cylinders.

Pump Control "Fine Inching" Mode

Special pump setting, selectable from the operator's cab, that allows very slow movements of load hoist drums, boom hoist drum, and travel for precision work.

Hydraulic Reservoir

77 gal (291L), equipped with sight level gauge. Diffusers built in for deaeration.

Filtration

Ten micron, full flow, line filter in the control circuit. All oil is filtered prior to entering the reservoir.

Counterbalance Valves

All hoist motors are equipped with counterbalance valves to provide positive load lowering and prevent accidental load drop if the hydraulic pressure is suddenly lost.

Load Hoist Drums

Each drum contains a pilot controlled, bi-directional, axial piston motor and a planetary gear reduction unit to provide positive control under all load conditions.

- Power up/down and free-fall operation modes
- Automatic brake mode (spring applied, hydraulically released, band type brake)
- Grooved lagging
- Drum pawl controlled manually
- Electronic drum rotation indicators
- Mounted on anti-friction bearings
- 15.75 in (40.00cm) root diameter
- 31.50 in (80.00cm) flange diameter
- 16.09 in (40.87cm) width
- Bolt on spiral lagging for 0.88 in (22.22mm) wire rope. Bolts to the flange of front hoist drum. Used for dragline work.

The free-fall operation mode is designed to prevent load lowering even if the free-fall switch is accidentally activated.

The automatic brake mode meets all OSHA requirements for personnel handling.

Drum Clutches

Hydraulic two shoe clutch design that uses a 20 in (50.8cm) diameter x 5 in (12.7cm) wide shoe that expands internally to provide load control. Swept area is 314 in² (2 026cm²).

Drum Brakes

External contracting band design that uses a 31.5 in (80.01cm) diameter x 4.7 in (11.9cm) wide shoe. Spring applied, hydraulically released "automatic brake mode" or mechanical foot control.

Optional Third Hoist Drum

Mounts to the front or rear of the upper frame and is used in conjunction with a fleeting sheave and 3-sheave idler assembly to run the wire rope over the boom top section.

- Free-spooling capability for pile driving applications
- 10.63 in (27.0cm) root diameter
- 20 in (50.8cm) flange diameter
- 13.5 in (34.3cm) width
- Mounted on anti-friction bearings

Operator's Manual

Optional Fourth Hoist Drum

Mounts to the rear of the upper frame with gravity free fall for use in pile driving applications.

- 15.75 in (40.0cm) root diameter
- 31.50 in (80.0cm) flange diameter
- 10.63 in (27.0cm) width
- Mounted on anti-friction bearings

Boom Hoist Drum

Contains a pilot controlled, bi-directional, axial piston motor and a planetary gear reduction unit to provide positive control under all load conditions.

- Spring applied, hydraulically released, disc type brake controlled automatically
- Drum pawl controlled automatically
- Mounted on anti-friction bearings
- 12.6 in (32.0cm) root diameter
- 24.41 in (62.0cm) flange diameter
- 9.57 in (24.3cm) width

Boom Hoist System

Designed to lift off maximum boom or maximum boom plus jib unassisted. Operates up to a maximum boom angle of 82°. Boom hoist limit system limits maximum boom angle operation.

- Retractable gantry frame
- Pin-on bail frame
- 14-part reeving with 5/8 in (15.88mm) wire rope
- Bridle assembly
- Two 1.125 in (28.70mm) pendants
- Tubular boom backstops (telescopic type)
- Nylon sheaves contain sealed anti-friction bearings
- Boom speed from 0° – 82° is 60 seconds with no load.

Swing System

Pilot controlled bi-directional axial piston motors and planetary gear reduction units to provide positive control under all load conditions.

- Spring applied, hydraulically released, 360° multi-plate swing (park) brake
- Free swing mode when lever is in neutral position
- Two position positive house lock
- Audio/Visual swing alarm
- Maximum swing speed is 3.4 rpm

Counterweight

Consists of a two-piece design that can be easily lowered to the ground using the gantry.

- "A" counterweight consists of one, 14,000 lb (6 350kg) base slab
- Optional "B" counterweight consists of one, 10,000 lb (4 535kg)
- Optional "XL" counterweight package offers increased capacities for lift and piling applications. It consists of one, 4,630 lb (2 100kg) upper counterweight and two, 4,300 lb (1 950kg) side frame counterweights. *Not for duty cycle application. Side frame counterweight not designed to self-assemble.*

Operator's Cab

Fully enclosed modular steel compartment is independently mounted and padded to protect against vibration and noise.

- All tinted/tempered safety glass
- Sliding entry door and front window
- Door and window locks
- Hot water heater
- Air conditioner
- Sun visor
- Cloth seat
- Circulating fan
- Windshield wipers and washer
- Dry chemical fire extinguisher
- Engine instrumentation panel (tachometer, voltmeter, engine oil pressure, engine water temperature, fuel level, hydraulic oil temperature, hour meter, and service monitor system)
- Mechanical drum rotation indicators for front and rear hoist drums
- Six way adjustable seat
- Hand and foot throttle
- Fully adjustable single axis controls
- Swing lever with swing (park) brake and horn on handle
- Bubble type level
- Ergonomic gauge layout
- Controls shut off lever
- Right hand control stand is adjustable by electric motor for operator comfort.

Rated Capacity Limiter System

The Rated Capacity Limiter System is a boom hoist load cell system. This system provides the operator with useful geometrical data, to include:

- Main Boom Length
- Main Boom Angle
- Jib Length
- Jib Angle
- Operating Mode
- Load Radius
- Boom Tip Height
- Audible Alarm
- Pre-Warning Light
- Overload Light
- Load On Hook
- Function kick-outs including over load
- Operator settable stops (ramped stops)
- Anti-Two Block Indicator
- Boom hoist dead end load cell (no lineriders)

Machinery House

Hinged doors (two on right side, three on left side) for machinery access. Equipped with rooftop access ladder and skid resistant finish on roof.

Catwalks

Standard on right and left sides. Catwalks fold up and pin for reduced travel width.

Operator's Manual

Lower Structure

Carbody

Lower Frame

All welded box construction frame with precision machined surfaces for turntable bearing and rotating joint.

- 7 ft 9.31 in (2.37m) overall width
- 10 ft 9.12 in (3.28m) overall length

Side Frames

Side Frames

All welded, precision machined, steel frames can be hydraulically extended and retracted by a hydraulic cylinder mounted in the lower frame.

- 11 ft 2 in (3.40m) extended gauge
- 8 ft 8.7 in (2.66m) retracted gauge
- 17 ft 8 in (5.38m) overall length
- 36 in (0.91m) wide track shoes
- Optional 30 in (0.76m) wide track shoes
- Sealed (oil filled) idler and drive planetaries
- Compact travel drives
- Hydraulic self adjusting tracks

Track Rollers

- Eight sealed (oil filled) track rollers per side frame
- Heat treated, mounted on anti-friction bearings

Tracks

Heat treated, self-cleaning, multiple hinged track shoes joined by one-piece full floating pins; 50 shoes per side frame

Take Up Idlers

Cast steel, heat treated, self-cleaning, mounted on sealed tapered roller bearings

Travel and Steering

Travel and Steering

Each side frame contains a pilot controlled, bi-directional, axial piston motor and a planetary gear reduction unit to provide positive control under all load conditions.

- 2-speed travel
- Individual control provides smooth, precise maneuverability including full counter-rotation.
- Spring applied, hydraulically released disc type brake controlled automatically
- Maximum travel speed is 2.36 mph (3.80km/h) in high speed and 1.3 mph (2.09km/h) in low speed.
- Designed to 40% gradeability

Attachment and Options

Conventional Angle Boom 40–140 ft (12.19–42.67m)

Basic Boom

40 ft (12.19m) two-piece design that utilizes a 20 ft (6.10m) base section and a 20 ft (6.10m) open throat top section with in-line connecting pins on 42 in (1.06m) wide and 42 in (1.06m) deep centers.

- Boom foot on 45.2 in (1.15m) centers
- 4 x 4 x 0.38 in (101.6 x 101.6 x 9.5mm) T-1 angle chords for base section
- 4 x 4 x 0.31 in (101.6 x 101.6 x 7.87mm) HSLA angle chords for top section
- Top section includes mounting lugs for all optional attachments
- Bridle guide system on boom base
- Skywalk platform
- Hooks provided on the base section for handling boom
- Two deflector rollers on top section
- Permanent skid pads mounted on top section to protect head machinery
- Four, 18 in, (0.46m) root diameter steel sheaves mounted on sealed anti-friction bearings
- Mechanical boom angle indicator

Boom Extensions

The following table provides the lengths available and the suggested quantity to obtain maximum boom in 10 ft (3.05m) increments. Midpoint pendant connections are not required.

- Deflector roller on top of each section
- Appropriate length pendants
- Maximum tip height of 144 ft (43.90m)

Boom Extensions		Quantity For Max Boom
ft	m	
10	3.05	2
20	6.10	1
30	9.14	2

Optional

- Clam head machinery – Two 18 in (0.46m) root diameter sheaves mounted on sealed anti-friction bearings and wire rope roller that bolts to the bottom of boom top.
- Drag head machinery – One 18 in (0.46m) root diameter wide mouth drag sheave mounted on greasable bearings. Two 18 in (0.46m) root diameter steel sheaves mounted on sealed anti-friction bearings. Wire rope roller bolts to bottom of boom top.

Tubular Jib 20–50 ft (6.10–15.24m)

Basic Tube Jib

20 ft (6.10m) two-piece design that utilizes a 10 ft (3.05m) base section and a 10 ft (3.05m) top section with in-line connecting pins on 30 in (0.76m) wide and 24 in (0.61m) deep centers.

- 1.5 in (38.1mm) diameter tubular chords
- One 16.5 in (0.42m) root diameter steel sheave mounted on sealed anti-friction bearings
- 10 ft (3.05m) jib extensions are available to provide jib lengths of 30–50 ft (9.14–15.24m) in 10 ft (3.05m) increments
- Jib offset angles at 5°, 17.5°, and 30°
- The maximum tip height of boom + jib is 163 ft (49.68m).

Operator's Manual

Auxiliary Tip Extension

Designed to use in place of jib to provide clearance between working hoist lines. The extension is equipped with two nylon 18.12 in (0.46m) root diameter nylon sheaves mounted on sealed anti-friction bearings. Maximum capacity is 9 Tons (8.16mt).

Pile Driver Lead Adaptor

Designed to mount on the boom top section to provide a single 3.63 in (92.1mm) pin connection for fixed leads.

Boom Folding Equipment

Consist of bolt on brackets and pins to allow folding 50 ft (15.24m) or 70 ft (21.34m) of boom for transport.

Transport Weights

Base Crane: Rigid boom backstops, 77 gal (291L) of fuel, catwalks (left and right side), 20 ft (6.10m) base section, bridle/spreader bar, boom hoist reeving, 600 ft (182.88m) of type 'DB' front hoist wire rope, 500 ft (152.40m) of type 'RB' rear hoist wire rope, and 36 in (914mm) track shoes.

Item Description	Gross Weight		Transport Loads	
	lb	(kg)	#1	#2
Base Crane	68,809	31 212	1	
Add "A" Counterweight	14,000	6 350	1	
Add "B" Counterweight	10,000	4 536	1	
Add "XL" Upper Counterweight	4,630	2 100		
Add "XL" Side Counterweight (2)	4,300	1 950		
Add Hydraulic Third Drum Without Wire Rope	1,053	478		
Add 3 Sheave Assembly to the Top Section	390	177		
Add 20 ft (6.10m) Angle Top Section with 4 Lifting Sheaves	2,711	1 230		1
Add 20 ft (6.10m) Angle Top Section with 2 Clam Sheaves	2,680	1 216		
Add 20 ft (6.10m) Angle Top Section with 1 Drag Sheave and 2 Lifting Sheaves	2,748	1 246		
Add 10 ft (3.05m) Angle Extension with Pins and Pendants	781	354		2
Add 20 ft (6.10m) Angle Extension with Pins and Pendants	1,335	606		1
Add 30 ft (9.14m) Angle Extension with Pins and Pendants	1,832	831		2
Add Boom Folding Equipment	500	227		
Add Tagline Winder	650	295		
Add Fairleader	1,274	578		
Add Pile Driving Adapter	198	90		
Add 20 ft (6.10m) Tubular Jib with Offset Pendants	1,177	534		1
Add 10 ft (3.05m) Tubular Jib Extension	195	88		2
Add Auxiliary Tip Extension	640	290		
Add Holding Wire Rope — 0.75 in (19.05mm) x 145 ft (44.20m) Type 'DB'	151	68		
Add Closing Wire Rope — 0.75 in (19.05mm) x 180 ft (54.86m) Type 'DB'	187	85		
Add 0.88 in (22.35mm) Front Drum Lagging	327	148		
Add Inhaul Wire Rope — 0.88 in (22.35mm) x 95 ft (28.96m) Type 'M'	128	58		
Add Third Drum Wire Rope — 0.63 in (16.00mm) x 385 ft (117.35m) Type 'ZB'	312	141		
Add 8.5 Ton (7.7mt) Hook Ball — Non-Swivel or Swivel	360	163		1
Add 40 Ton (36.3mt) 4 Sheave Hook Block	780	354		
Add 60 Ton (54.4mt) 4 Sheave Hook Block	1,110	503		1
Replace 36 in (914mm) Track Shoes with 30 in (762mm)	-3,530	-1 601		
Remove Front Hoist Wire Rope — 0.75 in (19.05mm) x 600 ft (182.88m) Type 'DB'	-624	-283		
Remove Jib Hoist Wire Rope — 0.75 in (19.05mm) x 500 ft (152.40m) Type 'RB'	-550	-249		
Remove 20 ft (6.10m) Angle Base Section	-1,757	-797		
Remove 50 gal (189.3L) of Fuel	-362	-164		
Approximate Total Shipping Weight	lb		92,809	12,309
	kg		42 097	5 583

Notes:

Estimated weights vary by +/- 2%. Numbers in the load columns represent quantities.
 Estimated transport loads assume the load out consist of 140 ft (39.62m) of angle boom, 50 ft (15.24m) of jib, and "AB" counterweight.
 Support loads were targeted at 45,000 lb (20 412kg), 8 ft 6 in (2.59m) wide, 48 ft (14.63m) long, and 13 ft 6 in (4.11m) high using a drop deck trailer.
 This may vary depending on state laws, empty truck/trailer weights, and style of trailer.

Operator's Manual

Working Weights

Option	Description	36" (914mm) Track Shoes		30" (762mm) Track Shoes	
		Gross Weight lb (kg)	Ground Bearing Pressure psi (kg/cm ²)	Gross Weight lb (kg)	Ground Bearing Pressure psi (kg/cm ²)
1	Base machine equipped with 40 ft (12.19m) of boom, "A" counterweight, 600 ft (182.88m) front hoist wire rope, 500 ft (152.40m) rear hoist wire rope, 77 gal (291L) of fuel, 60 Ton (54.43mt) hook block and a 200 lb (90.7kg) operator.	86,830 (39 385)	6.85 (0.48)	83,384 (37 822)	7.90 (0.56)
2	Option #1 plus "B" counterweight and 100 ft (30.48m) of boom extensions to obtain 140 ft (39.62m) of main boom.	100,778 (45 712)	7.95 (0.56)	97,332 (44 149)	9.22 (0.65)
3	Option #2 plus 50 ft (15.24m) of jib and 8.5 Ton (7.7mt) hook ball – subtract 30 ft (9.14m) of boom extensions to obtain 110 + 50 ft (33.53 + 15.24m) of main boom plus jib.	101,068 (45 844)	7.98 (0.56)	97,622 (44 280)	9.24 (0.65)

Notes: Ground bearing pressure is based on the total weight distributed evenly over the track contact area.
Total contact area for 30" (762 mm) track shoes is 10,560 in² (68 129 cm²). Total contact area for 36" (914 mm) track shoes is 12,672 in² (81 755 cm²).

Transport Drawings

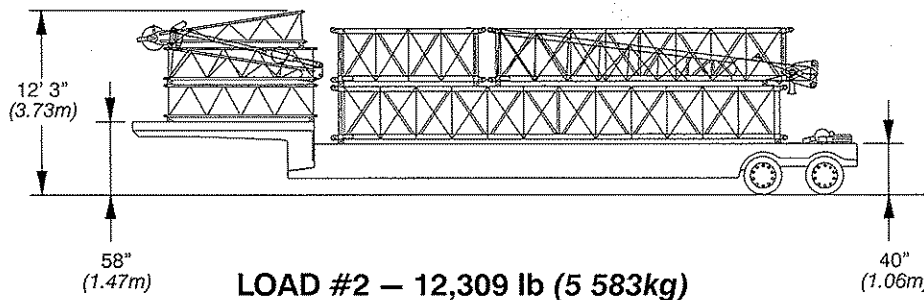
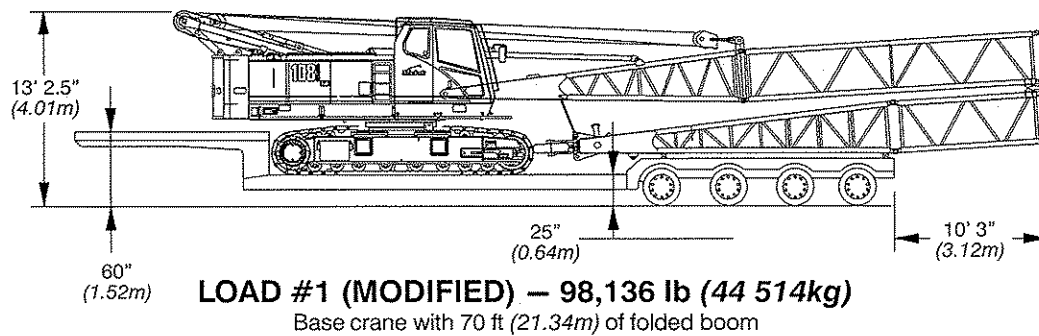
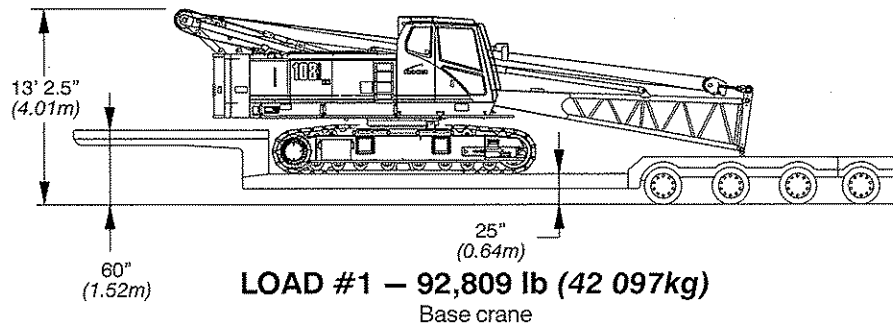

20 ft (6.10m) top section, two 10 ft (3.05m) boom extensions, 20 ft (6.10m) boom extension, two 30 ft (9.14m) boom extensions, 20 ft (6.10m) jib with offset pendants, two 10 ft (3.05m) jib extensions, 8.5 Ton (7.7mt) hook ball, and 60 Ton (54.4mt) hook block

Operator's Manual

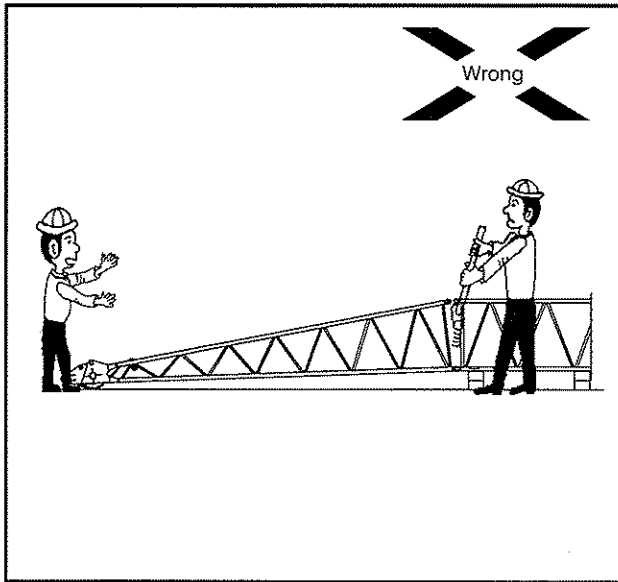

Figure 1-16
Block under the boom top section.

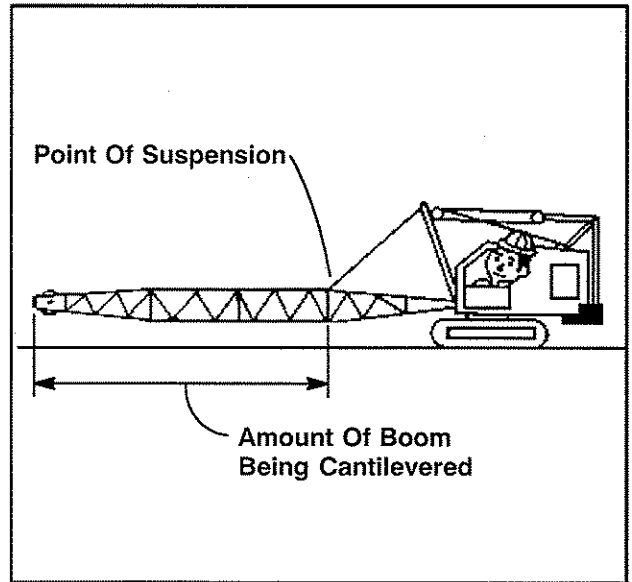

Figure 1-17
Cantilevering The Boom

5. Always wear proper eye protection when driving connecting pins.
6. Block under the boom top section before unpinning from extensions. Since the top section is tapered, it will fall to the ground when unpinned. This could result in an accident.
7. Do not remove any connecting pins which are located behind the pendants which are supporting the boom.
8. Stay clear of pinch points when aligning boom section connecting lugs. Do not place your fingers in connecting pin holes.
9. Know the maximum amount of boom that can be cantilevered, projected beyond point of suspension, during boom assembly and disassembly. Exceeding this amount can cause boom or boom suspension failure. Refer to Section 4 of this Operator's Manual for specific boom assembly procedures.
10. If the boom length is such that mid-point suspensions are required, ensure they are installed and properly adjusted. Long booms may buckle in the middle from their own weight without this suspension.
11. Use caution when disconnecting the dead end of wire ropes. Reeved wire rope can become twisted on the sheaves. When the dead end pin or socket is removed, the wire rope may spin.

Operator's Manual

Load Hoist Performance

Front or Rear Drum – 3/4 in (19mm) Wire Rope

Wire Rope Layer	Maximum Line Pull		No Load Line Speed		Full Load Line Speed		Pitch Diameter		Layer		Total	
	lb	kg	ft/min	m/min	ft/min	m/min	in	mm	ft	m	ft	m
1	32,323	14 662	264	80.5	89	27.1	16.5	419	86	26.3	86	26.3
2	29,630	13 440	288	87.8	97	29.6	18.0	457	94	28.5	180	54.9
3	27,350	12 406	312	95.1	105	32.0	19.5	495	101	30.7	281	85.6
4	26,396	11 520	336	102.4	113	34.5	21.0	533	108	32.9	389	118.5
5	23,703	10 752	360	109.7	121	37.0	22.5	571	115	35.1	504	153.5
6	22,222	10 080	384	117.0	129	39.4	24.0	610	122	37.2	626	190.8
7	20,914	9 487	408	124.3	137	41.9	25.5	648	129	39.4	755	230.2
8	19,752	8 960	432	131.7	145	44.4	27.0	686	136	41.6	892	271.8
9			Storage Layer Only				28.5	724	144	43.8	1,035	315.6

Front Drum – 7/8 in (22mm) Wire Rope

Wire Rope Layer	Maximum Line Pull		No Load Line Speed		Full Load Line Speed		Pitch Diameter		Layer		Total	
	lb	kg	ft/min	m/min	ft/min	m/min	in	mm	ft	m	ft	m
1	26,188	11 879	330	100.6	110	33.5	20.4	517	86	26.3	86	26.3
2	24,116	10 939	358	109.2	119	36.3	22.1	562	94	28.5	180	54.9

Boom Hoist Drum – 5/8 in (16mm) Wire Rope

Wire Rope Layer	Maximum Line Pull		No Load Line Speed		Full Load Line Speed		Pitch Diameter		Layer		Total	
	lb	kg	ft/min	m/min	ft/min	m/min	in	mm	ft	m	ft	m
1	17,080	7 747	194	59.2	172	52.5	13.2	336	48	14.8	48	14.8
2	15,605	7 078	213	64.8	188	57.4	14.5	368	53	16.1	101	30.8
3	14,364	6 515	231	70.4	205	62.4	15.7	399	57	17.3	158	48.2
4	13,306	6 036	249	76.0	221	67.3	17.0	431	61	18.6	219	66.8
5	12,393	5 622	268	81.6	237	72.3	18.2	463	65	19.9	284	86.6
6	11,598	5 261	286	87.2	253	77.2	19.5	495	69	21.1	354	107.8
7	10,898	4 943	304	92.8	270	82.2	20.7	526	74	22.4	427	130.2
8	10,278	4 662	323	98.4	286	87.2	22.0	558	78	23.7	505	153.9

Optional Third Drum – 5/8 in (16mm) Wire Rope

Wire Rope Layer	Maximum Line Pull		No Load Line Speed		Full Load Line Speed		Pitch Diameter		Layer		Total	
	lb	kg	ft/min	m/min	ft/min	m/min	in	mm	ft	m	ft	m
1	15,041	6 822	157	48	143	43.6	11.3	286	57	17.4	57	17.4
2	13,537	6 140	175	53	159	48.5	12.5	318	64	19.5	121	36.9
3	12,307	5 582	192	59	175	53.3	13.8	349	70	21.3	192	58.5
4	11,282	5 117	210	64	191	58.0	15.0	381	76	23.1	269	82.0
5	10,414	4 724	228	69	207	63.1	16.3	413	83	25.2	352	107.3
6	9,671	4 387	245	75	223	68.0	17.5	445	89	27.1	442	134.7

Optional Fourth Drum – 3/4 in (19mm) Wire Rope

Wire Rope Layer	Maximum Line Pull		No Load Line Speed		Full Load Line Speed		Pitch Diameter		Layer		Total	
	lb	kg	ft/min	m/min	ft/min	m/min	in	mm	ft	m	ft	m
1	22,352	10 139	189	57.7	126	38.5	16.5	419	56	17.1	56	17.1
2	20,489	9 294	207	63.0	138	42.0	18.0	457	61	18.7	117	35.8
3	18,913	8 579	224	68.2	149	45.5	19.5	495	66	20.2	184	56.0
4	17,562	7 966	241	73.5	161	49.0	21.0	533	71	21.8	255	77.8
5	16,391	7 435	258	78.7	172	52.5	22.5	571	77	23.3	332	101.1
6	15,367	6 970	275	84.0	184	56.0	24.0	610	82	24.9	413	126.0
7	14,463	6 560	293	89.2	195	59.5	25.5	648	87	26.4	500	152.4
8	13,659	6 196	310	94.5	207	63.0	27.0	686	92	28.0	592	180.4
9	12,940	5 870	327	99.7	218	66.5	28.5	724	97	29.6	689	210.0
10	12,293	5 576	344	105.0	230	70.0	30.0	762	102	31.1	791	241.1

Operator's Manual

Wire Rope Application	Diameter		Type	Max. Permissible Load		Wire Rope Descriptions
	in	mm		lb	kg	
Boom Hoist	5/8	16	W	11,700	5 307	6 x 26 (6 x 19 Class) – Extra Improved Plow Steel – Preformed – Right Lay – Alternate Lay – I.W.R.C.
Front Hoist	3/4	19	DB	16,800	7 620	6 X 26 (6 X 19 Class), Warrington Seale, E.I.P.S., Preformed, Right Regular Lay, I.W.R.C.
Rear Hoist	3/4	19	RB	12,900	5 851	19 X 19 Rotation Resistant Compacted Strand – High Strength – Preformed, Right Regular Lay
Third Drum	5/8	16	ZB	11,080	5 026	34 x 7 – Non-rotating – Extra Improved Plow Steel – Right Regular or Right Lang Lay
Clamshell (Holding)	3/4	19	DB	16,800	7 620	6 X 26 (6 X 19 Class), Warrington Seale, E.I.P.S., Preformed, Right Regular Lay, I.W.R.C.
Clamshell (Closing)	3/4	19	DB	16,800	7 620	6 X 26 (6 X 19 Class), Warrington Seale, E.I.P.S., Preformed, Right Regular Lay, I.W.R.C.
Dragline (Hoist)	3/4	19	DB	16,800	7 620	6 X 26 (6 X 19 Class), Warrington Seale, E.I.P.S., Preformed, Right Regular Lay, I.W.R.C.
Dragline (Inhaul)	7/8	22	M	22,740	10 315	6 X 25 (6 X 19 Class), Filler Wire, E.I.P.S., Preformed, I.W.R.C., Right Lay, Lang Lay

Operator's Manual

Attachments

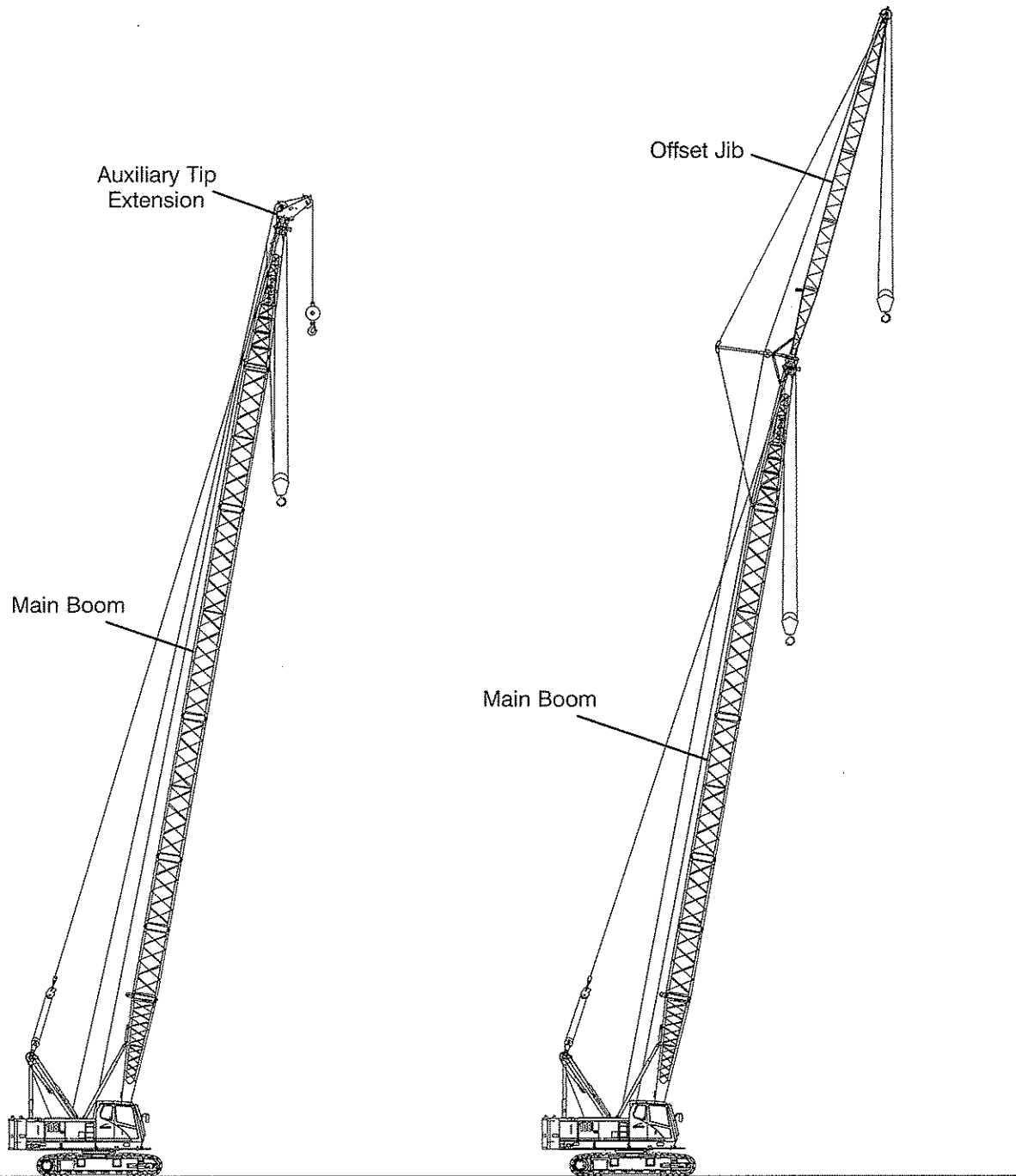

40–140 ft (12.20–42.67m)
Main Boom With Auxiliary
Tip Extension

40–110 ft (12.20–33.53m)
Main Boom With 20–50 ft
(6.10–15.24m) Jib

Operator's Manual

Main Boom Make-up

Boom Length ft (m)		Base	Boom Extensions ft (m)				Top
ft	m	20 (6.14)	10 (3.05)	20 (6.14)	30 (9.10)	20 (6.14)	
40	12.20	1				1	
50	15.24	1	1			1	
60	18.29	1		1		1	
70	21.34	1			1	1	
80	24.38	1	1		1	1	
90	27.43	1		1	1	1	
100	30.48	1			2	1	
110	33.53	1	1		2	1	
120	36.58	1		1	2	1	
130	39.62	1	1	1	2	1	
140	42.67	1	2	1	2	1	

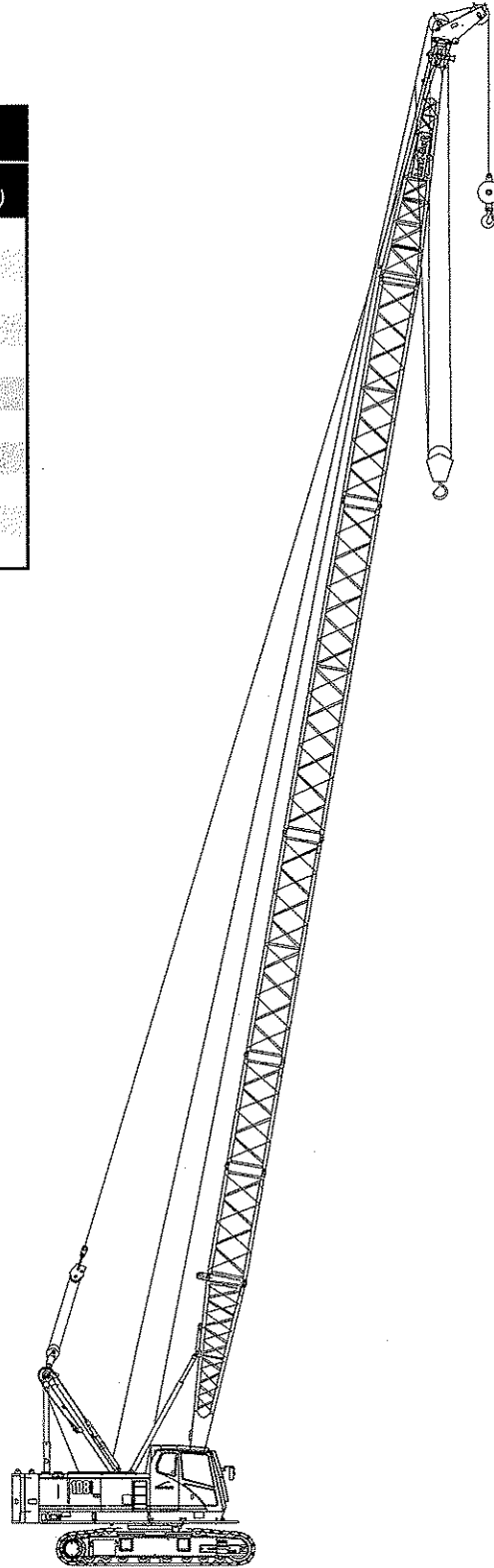

Operator's Manual

Duty Cycle Working Range Diagrams

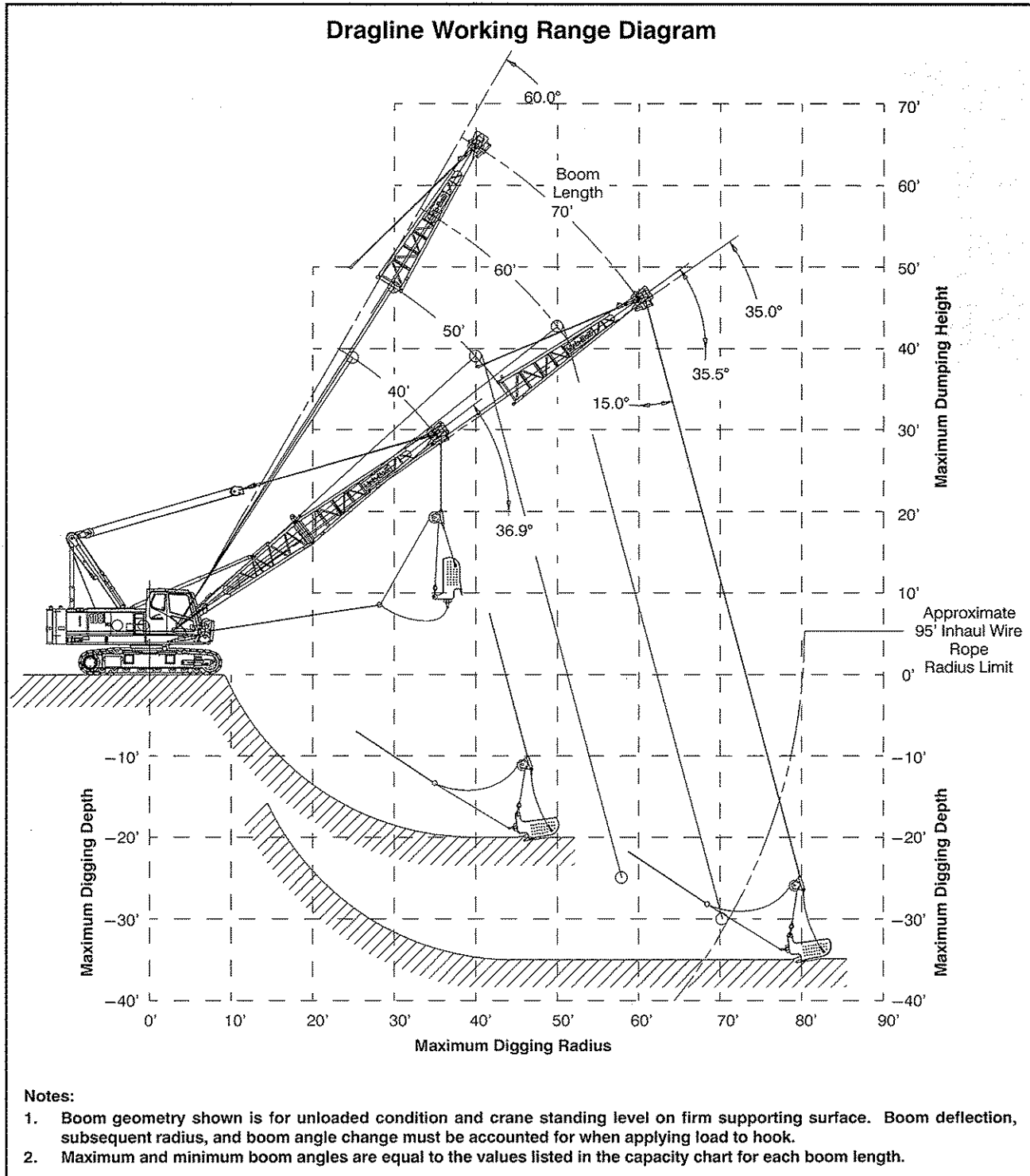

Operator's Manual

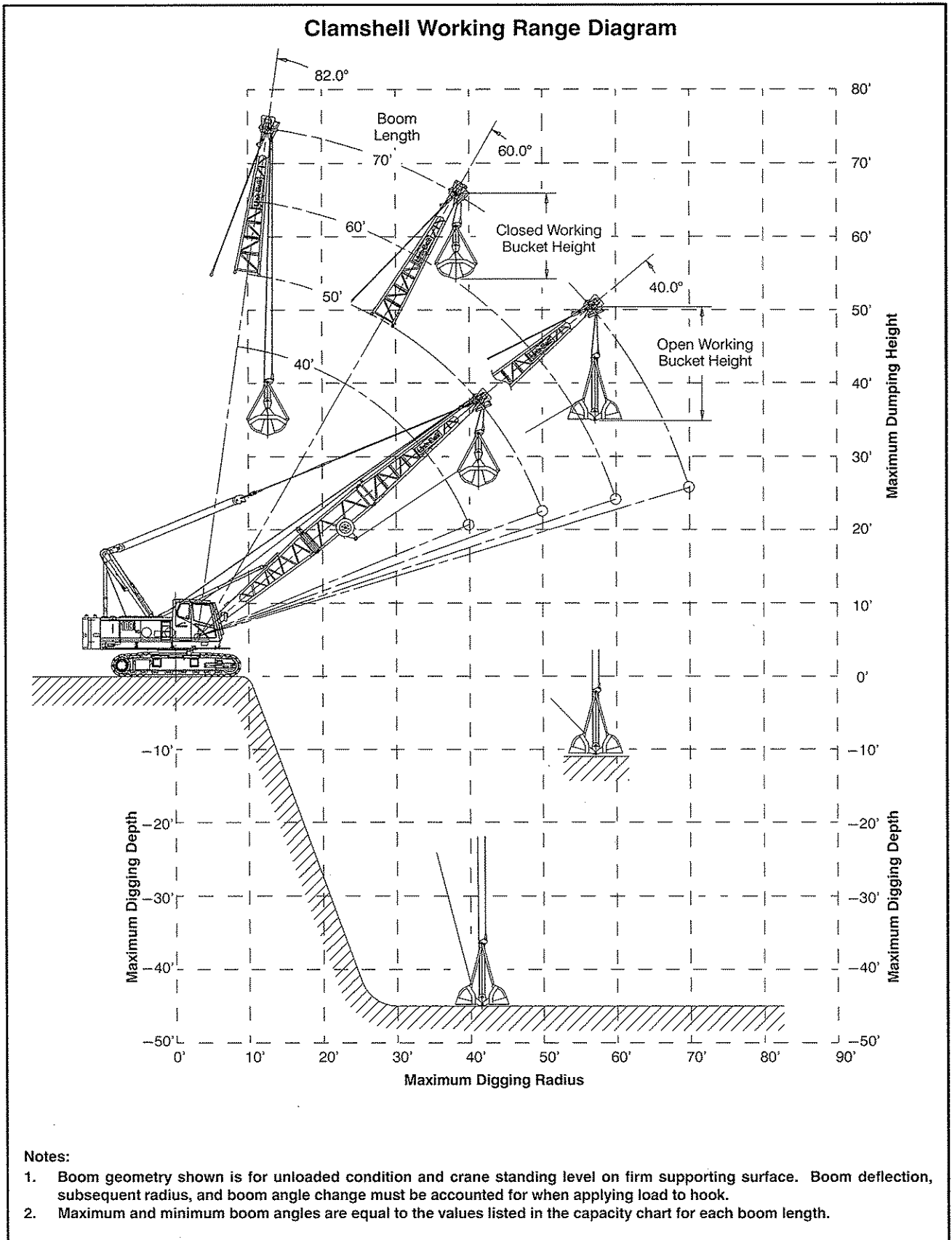

Operator's Manual

Main Boom Working Range Diagram

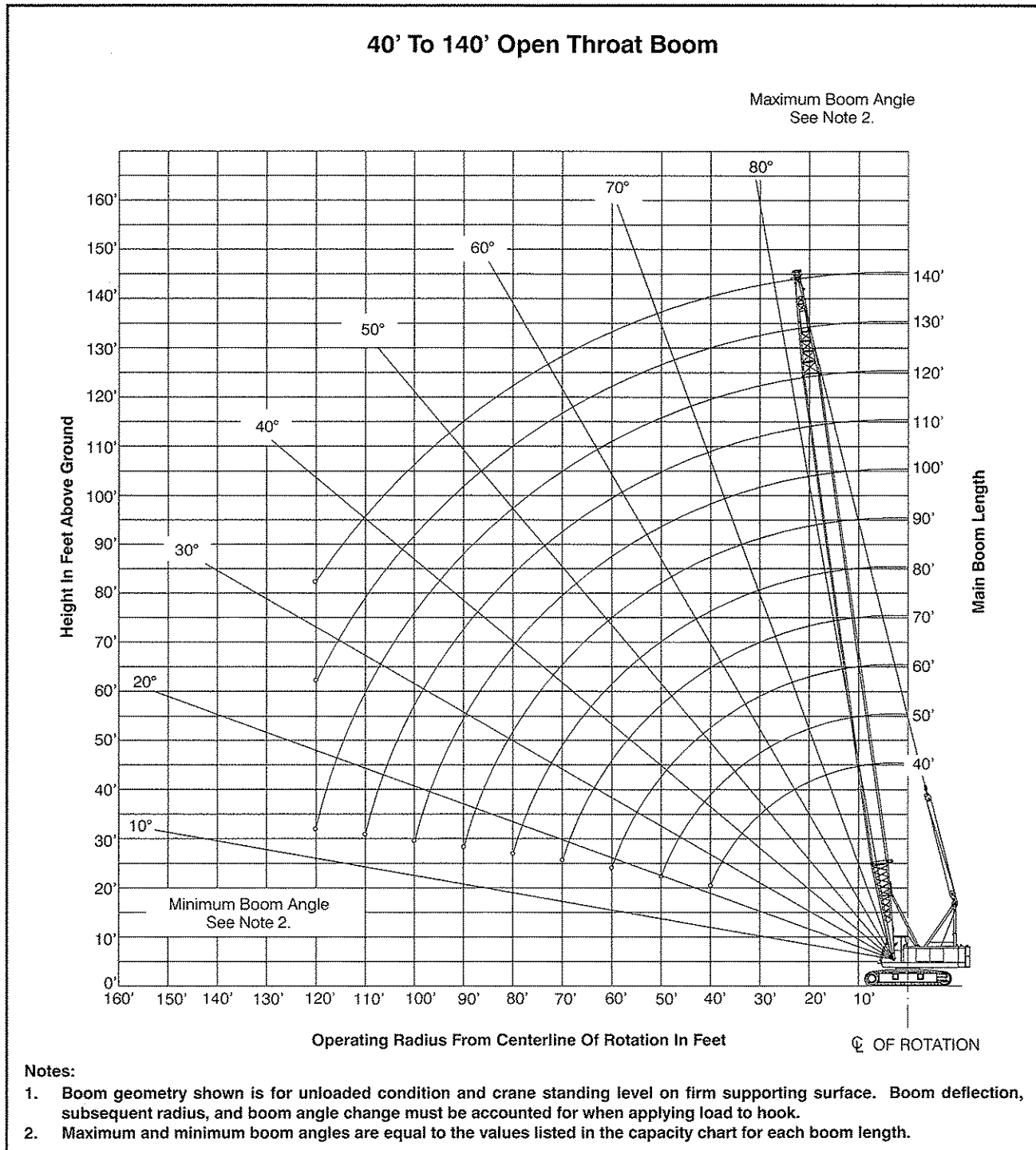

Operator's Manual

Jib Attachment Make-up

Jib Length ft (m)	Base	Jib Extensions	Top
	10 ft (3.05m)	10 ft (3.05m)	10 ft (3.05m)
20 (6.10)	1		1
30 (9.15)	1	1	1
40 (12.19)	1	2	1
50 (15.24)	1	3	1

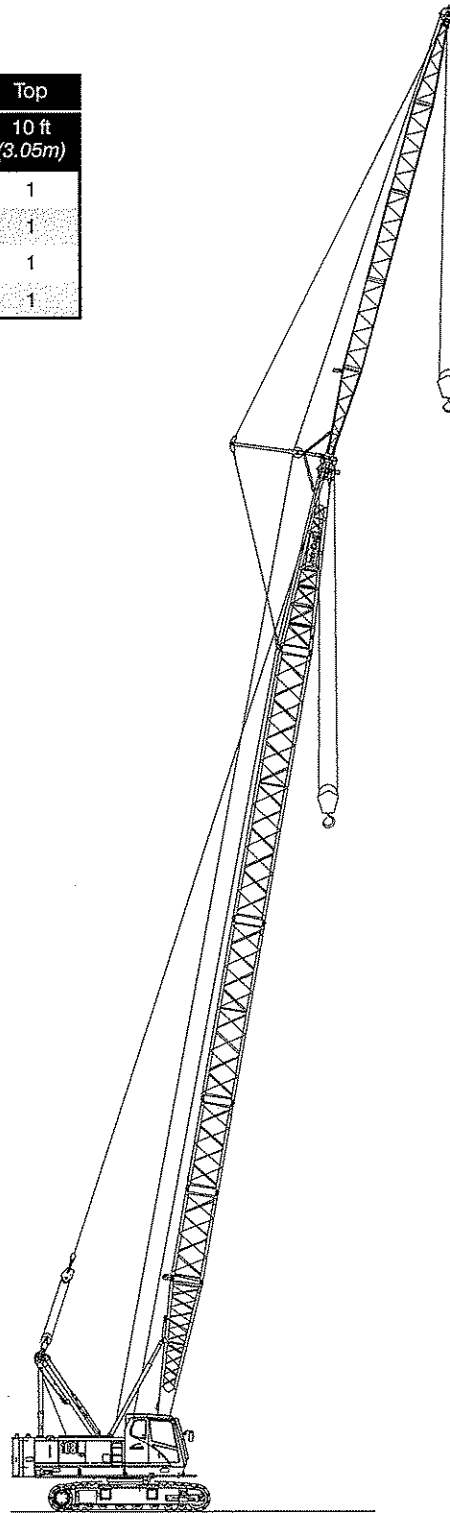

Operator's Manual

Jib Attachment Working Range Diagram

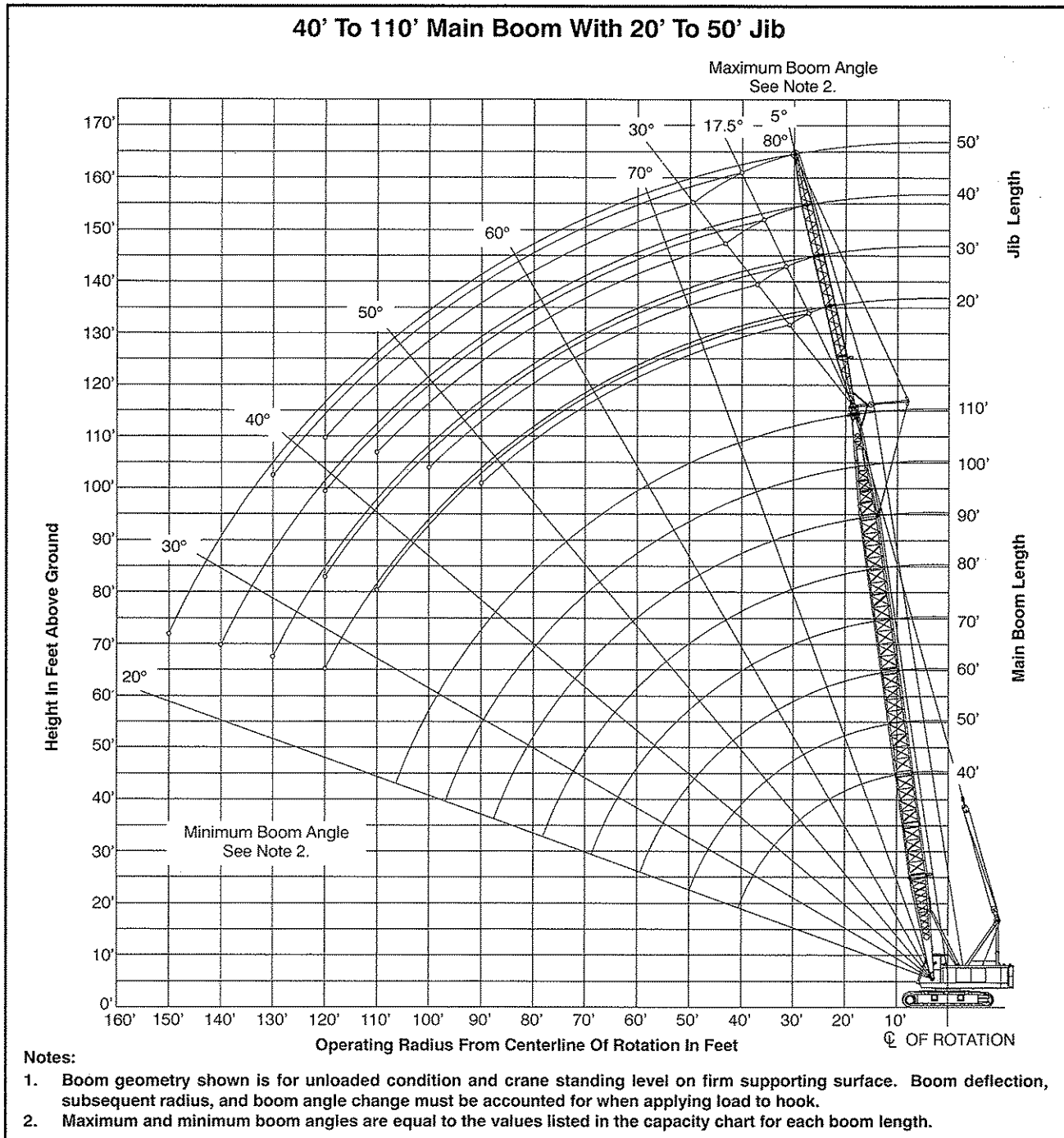

Operator's Manual

Table Of Contents

Fundamental Terms	6-1
-------------------------	-----

Operator's Manual

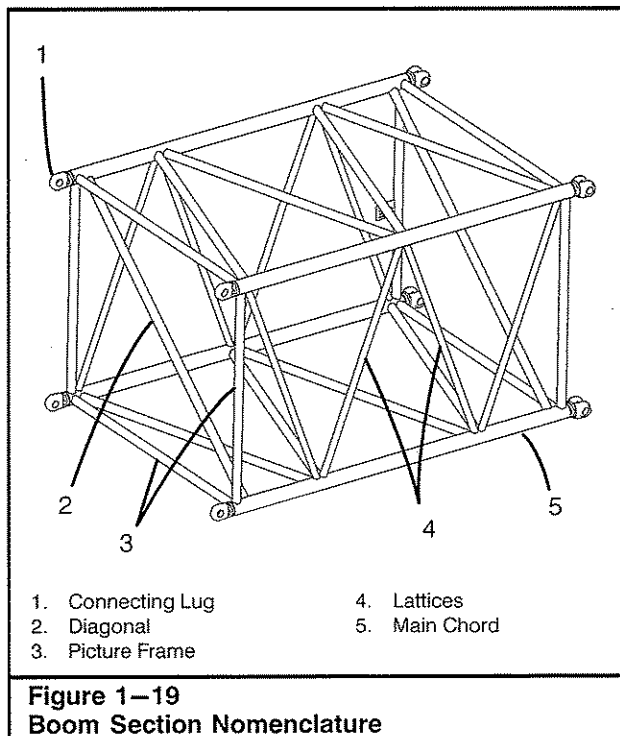
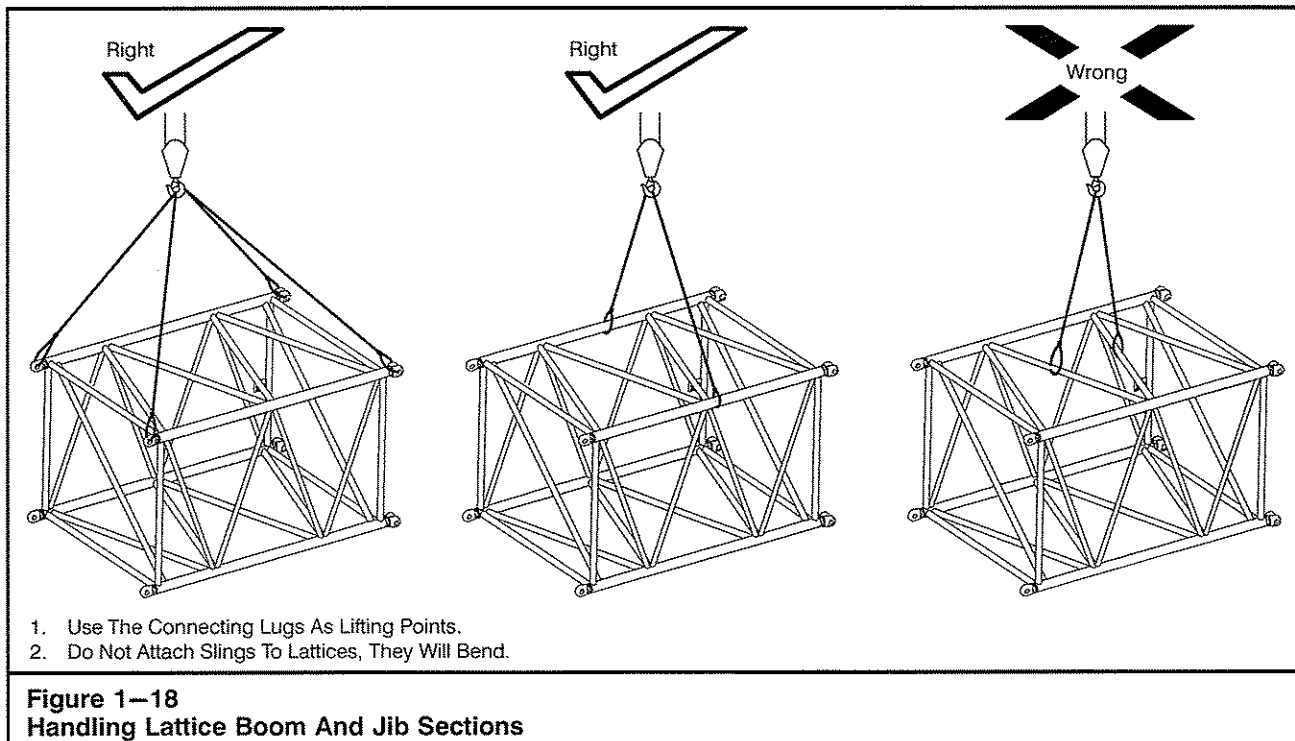

12. Use care handling the boom and jib sections when loading, transporting, and unloading. Damage that occurs during these operations can go undetected and could result in failure of the attachment. Do not attach slings to the lattices as they will bend. Use the connecting lugs or main chords as the lifting points. Use only soft nylon straps minimum 3 inches (7.62cm) in width of sufficient strength to handle sections.
13. Block under and between the boom and jib sections when loading them on a transport vehicle. When securing sections to a transport vehicle, it is best to use synthetic webs or slings. If using wire rope slings, pad the section to protect it from damage. Do not overtighten the tie downs or the section may be damaged. Do not use chain tie downs, as they may dent and damage the section.
14. Thoroughly inspect all the elements of each boom or jib section before installing it on the crane. Check each main chord, picture frame, diagonal, lattice, and connecting lug for bends, dents, and cracked or corroded welds. Picture frames must be square. Do not use any boom or jib section that is even slightly damaged. Contact your Link-Belt Distributor for the proper repair procedures.

Operator's Manual

Notes:

Operator's Manual

Fundamental Terms

Many terms are used which refer to crane function, assembly, operation, and maintenance. The following list gives a brief definition as to how the terms are used in this Operator's Manual and how they fit this particular crane.

Accumulator: A container in which fluid is stored under pressure as a source of hydraulic energy.

Aeration: The condition when air is present in the hydraulic fluid. This causes the fluid to appear milky and components to operate erratically because of the compressibility of air trapped in the fluid.

Annually: Once a year

Anti-Two Block System: A system of electromechanical devices used to prevent the crane operator from two blocking the crane. See "Two Block".

Attachment: The lattice boom assembly and either an angle jib or tubular jib or the combination of both.

Audio/Visual Warning System: 1. Alarm device that signals the operator of low engine oil pressure, high engine coolant temperature and high hydraulic oil and transmission oil temperature. 2. Device utilizing buzzer and/or lights as a signal of approaching two block and/or overload condition. See "Rated Capacity Indicator".

Automatic Brake: Drum brake system that is applied automatically any time the drum control lever is in neutral.

Backstop: A device used to limit the angle of the boom, jib, or mast at the highest recommended angle.

Backward Stability: Resistance to overturning of the crane in a rearward direction.

Bail: A frame equipped with sheaves and connected to the gantry. The bail is used in conjunction with the boom hoist drum and bridle to alter the crane's boom angle.

Band Brake: Circular external contracting type brake having a strap lined with heat and wear resistant friction material.

Base Section: The lower most section of a lattice boom or jib.

Basic Boom: Lattice boom attachment made up of only the base and top sections of the boom.

Basic Jib: Jib attachment made up of only the base and top section of the jib.

Boom: Lattice structure consisting of multiple sections, pinned together to a specific length, and their support system.

Boom Angle: The angle above or below horizontal of the longitudinal axis of the boom.

Boom Angle Indicator: An accessory which measures the angle of the boom relative to horizontal.

Boom Chord: A main corner structural member of a boom.

Boom Foot: Base of boom where it attaches to the upper revolving frame.

Boom Hoist: Wire rope drum and its drive, or other mechanism, for controlling the angle of the boom.

Boom Lattice: Structural truss members at angles to, and supporting the boom chords of a boom.

Boom Length: The distance along a straight line through the centerline of the boom foot pin to the centerline of the boom head sheave shaft, measured along the longitudinal axis of the boom.

Boom Section: Individual lattice structures which are pinned together to form the boom attachment. Crane lattice booms are usually in two basic sections, top and base. Such booms may be lengthened by insertion of one or more additional extension sections.

Bridle: A frame equipped with sheaves and connected to the boom by stationary wire ropes called pendants. The bridle is used in conjunction with the boom hoist drum and bail to alter the crane's boom angle.

Bypass: A secondary passage of fluid, air, or electrical flow, in addition to the main flow path.

Cantilever: Any unsupported boom or jib section that projects beyond the supporting point.

Capacity Chart: A chart for the crane which gives rated lifting capacities for the crane under different load conditions and setups. Capacity charts are in the Crane Rating Manual.

Carbody: The lower frame upon which the revolving upper frame is mounted.

Carrier Roller (Lower Roller): Rollers of track mechanism which are not power driven but are used to guide the track along the top of the side frame.

Catwalk: Platforms attached to the crane that provide a walkway along the sides of the upper.

Cavitation: A condition where air is induced into a cavity, line, or chamber normally filled with oil. This condition can cause damage to pumps, cylinders, valves, etc.

Check Valve: A valve which permits flow in one direction only.

Operator's Manual

Chord: A main corner structural member of a boom or jib.

Circuit: A complete or partial path over which electrical current, air, or hydraulic fluid may flow.

Clamshell Bucket: A device consisting of two or more similar scoops hinged together and used for digging and moving material.

Closing Line: The wire rope reeved from a hoist drum to control closing of clamshell bucket.

Clutch: A friction, electromagnetic, hydraulic or pneumatic device for engagement or disengagement of power.

Compressibility: The change in volume of a fluid or gas when it is subjected to a unit change in pressure.

Concrete Bucket: Bucket for handling wet concrete, fitted with bail or bridle, usually handled on lifting crane for hoisting to dumping location.

Counterbalance Valve (Holding Valve): A valve which regulates fluid flow by maintaining resistance in one direction, but allows free flow in the other direction.

Counterweight: Weight used to supplement the weight of the crane in providing stability for lifting loads.

Cracking Pressure: The pressure at which a pressure actuated valve begins to open to allow flow.

Crane Rating Manual: A compilation of the necessary information needed to plan a safe lift with the crane. It includes instructions such as the allowable lifting capacity charts, Working Range Diagrams, Working Areas Diagram, etc.

Cylinder: A device which converts fluid power into mechanical force and motion. It usually consists of a moveable element such as a piston and piston rod, which operates within a cylindrical bore.

Delivery: The volume of fluid discharge by a pump in a given time, usually expressed in gallons per minute (gpm) or liters per minute (L/min).

Derricking: Operation of changing boom angle in a vertical plane. See "Boom Hoist".

Displacement: The quantity of fluid which can pass through a pump, motor, or cylinder in a single revolution or stroke.

Double Acting Cylinder: A cylinder in which fluid force can be applied in either direction.

Drag Rope (Inhaul Rope): Wire rope for pulling in bucket during dragline operations.

Dragline: Cranes with dragline attachments are generally used to excavate material from below the grade on which the crane is placed. A dragline bucket is loaded by the drag rope pulling it toward the crane, it is

lifted and carried by the hoist wire rope reeved over the boom point sheave, and is balanced by the dump rope interconnecting the drag and hoist wire ropes.

Drum Lagging: See "Winch Drum".

Drum Rotation Indicator: A device that is used to indicate winch drum motion and can also be used to monitor speed.

Extension (Boom Or Jib): Sections of the boom or jib which come in various lengths and are used to increase the overall length of the boom or jib.

Fairleader: A combination of sheaves and or rollers mounted at the front of the crane to guide the drag rope.

Filter: A device which functions to remove insoluble contaminants from a fluid by a porous media.

Flow Divider: A valve which divides a flow of oil into two streams.

Force: Any cause which tends to produce or modify motion. In hydraulics, total force is expressed by the product of pressure (P) and the area of the surface (A) on which the pressure acts. (Force = P X A)

Frame: Structure on which either upper or lower machinery is attached.

Free-Fall: Lowering of the hook and/or load without using power. The motion is caused by gravity and must be controlled by a brake.

Friction: The property which tends to resist the relative motion of one surface in contact with another surface. It always exerts a "Drag" in the direction opposite of the motion, thus consumes power.

Full Flow: In a filter, the condition where all the fluid must pass through the filter element.

Full Load Speed: The speed at which an engine runs when it is delivering its full rated horsepower.

Function Limiter (Function Lockout, Hydraulic Cut-outs, Hydraulic Kickouts): Devices incorporated into the anti-two block system, Rated Capacity Indicator, or Load Moment Indicator System which will disable the crane function of winch up and boom down (as applicable) as two block or overload situations approach.

Gradeability: The slope which a crane can climb expressed as a percentage. (45° equals 100% slope.)

Ground Pressure: Weight of crane divided by the area of the surface directly supporting the crane.

Head Machinery: An arrangement of sheaves on the end of an attachment used to reeve wire rope.

High Idle: Governed engine speed at full throttle and no load.

Operator's Manual

Hoist: Function of lifting and lowering loads.

Hoist Drum: A rotating cylindrical spool with side flanges used to wrap the winch wire rope during the raising and lowering of the load with the winch.

Hoist Rope (Hoist Wire Rope): The wire rope used to reeve the winch and the attachments for lifting loads.

Holding Valve: See "Counterbalance Valve".

Hook Ball: Ball with hook attached used in lifting service. It is used with one part of line only.

Hook Block: Block with hook attached used in lifting service. It may have a single sheave for two or three part line, or multiple sheaves for four or more parts of line.

House Assembly: The housing which covers the machinery mounted on the upper revolving frame

Hydraulic Reservoir (Sump Tank): The storage tank for hydraulic fluid.

Idler Roller: Rollers of track mechanism which are not power driven but are used to maintain proper tension on the track.

Inhaul Rope: See "Drag Rope".

Instability: A "tipping condition" in which the moments acting to overturn a crane exceed the moments acting to resist overturning.

Jib: A pendant supported extension attached to the boom head to provide added boom length for handling specified loads. The jib may be in line with the boom or offset.

Jib Chord: A main corner structural member of a jib.

Jib Lattice: Structural truss members at angles to, and supporting the jib chords of a jib.

Jib Section: Individual lattice structures which are pinned together to form the jib attachment. Crane lattice jibs are usually in two basic sections, top and base. Such jibs may be lengthened by insertion of one or more additional extension sections.

Lattice: Structural truss members at angles to, and supporting boom or jib chords in a boom or jib.

Lattice Boom: Boom of open construction with angle or tubular lattice between main corner members (chords) in the form of a truss.

Lifting Capacity: The rated load for any given load radius and boom angle under specified operating conditions and crane configurations.

Line Pull: The wire rope pull generated off a wire rope drum or lagging at a specified pitch diameter.

Line Speed: The wire rope velocity at a wire rope drum or lagging at a specified pitch diameter.

Live Mast: Frame hinged at or near the boom foot and extending above the cab for use in connection with supporting a boom. Head of live mast is usually supported and raised or lowered by the boom hoist wire ropes.

Load Indicator: A device for measuring and displaying the net load being lifted.

Load Line: Another term for "Hoist Rope/Hoist Wire Rope". In lifting crane service it refers to the main hoist. The secondary hoist is referred to as a "Whip Line".

Load Moment Indicator: See "Rated Capacity Indicator".

Load Radius: See "Radius".

Lock-Out: The stoppage of control of a given function.

Lower Roller: See "Track Roller".

LS: A track driven crawler crane.

Mat: Support, usually of timber or wire construction, for supporting pontoons or tracks on soft surfaces to add stability and/or distribute crane loads (reduce ground pressure).

Midpoint Pendants: Wire rope pendants used to support the center portion of a long lattice boom at lift off.

Motor (Hydraulic): 1. A rotary motion device which changes hydraulic energy into mechanical energy.
2. A rotary actuator.

Oil Cooler: A heat exchanger used to remove heat from hydraulic fluid.

Open Center Circuit: A circuit where the pump continuously circulates fluid through the control valves when they are in a neutral position.

Operational Aid: An accessory that provides information to facilitate operation of a crane or that takes control of particular crane functions without action of the operator when a limiting condition is sensed.

Operator's Cab: A housing which covers the operator's station.

Pawl: A pivoting locking lever which will permit movement in only one direction. Movement in the opposite direction can be achieved only by manually releasing the mechanism.

Pendant: A supporting wire rope, which under tension, maintains a constant distance between its points of attachment.

Pick And Carry: The crane operation of lifting a load and traveling with it suspended.

Pilot Pressure: Hydraulic pressure used to actuate or control hydraulic components.

Operator's Manual

Pinion: The small gear in a gear train which drives the other gears.

Pitch Diameter: Root diameter of drum, lagging, or sheave, plus the diameter of the wire rope.

Planetary: A set of gears used to either speed up or slow down the input vs the output to gain speed or power whichever is applicable.

Platform: A device (basket, work platform, bucket, cage, etc.) designed and fabricated with its intended use being to lift and position personnel.

Pontoon: The support which attaches to a jack to increase the supporting area.

Poppet: A disc, ball, or cone shaped part of certain valves, which when closed against a seat, prevents flow.

Port: The open end of a passage. It may be within or at the surface of a hydraulic component housing or body.

Power Take-Off (PTO): Device used for the transfer or transmission of engine power to the operating functions of the crane.

Pressure: Force per unit of area usually expressed in pounds per square inch (psi) or Kilopascals (kPa).

Pressure Drop: The reduction in pressure between two points in a line or passage due to the energy lost in maintaining flow.

Pressure Reducing Valve: A valve which limits the maximum pressure at its outlet regardless of the inlet pressure.

Pump (Hydraulic): A device which converts mechanical force and motion into hydraulic fluid flow.

Radius: The horizontal distance from the centerline of rotation of the crane, with no load, to the center of gravity of the hook or suspended load.

Rated Capacity Indicator (RCI): A device that automatically monitors radius, load weight, and load rating and warns the crane operator of an overload condition.

Rated Capacity Limiter (RCL): A device that automatically monitors radius, load weight, and load rating and prevents movements of the crane that would result in an overload condition.

Rated Load Indicator: See "Rated Capacity Indicator".

Reeving: Passing of wire ropes over pulleys and/or sheaves.

Relief Valve: A pressure operated valve which bypasses pump delivery to the reservoir, limiting system pressure to a predetermined maximum value.

Reservoir: A container for storage of fluid in a fluid power system.

Restriction: A reduced cross-sectional area in a line which produces a pressure drop.

Rigging Switch (System Override Switch): A switch which can be used to override any or all of the function limiters (cutouts) which have been activated on the crane during crane rigging/set up.

Rope: Refers to wire rope unless otherwise specified. See "Wire Rope".

Rotating Joint: Component which transfers fluid, air, or electricity between a stationary and a rotating member.

Schematic: A diagram or representation of a system showing everything in a simple way. No attempt is made to show the various devices in their actual relative positions. A schematic points out the operation of a circuit for troubleshooting purposes.

Seasonally: Four times per year.

Semiannually: Twice per year.

Shall: The word shall is to be understood as mandatory.

Shim Pack (Wedge Pack): Wedging mechanism used to secure the lower side frames to the lower.

Should: The word should is to be understood as advisory.

Side Frame: Supporting structure of the track mechanism. Side frames are attached to the lower frame and may be extendable and/or removable.

Single Acting Cylinder: A cylinder in which fluid power can only be used in one direction. Another force must be used to return the cylinder.

Spool: Term applied to almost any moving cylindrical shaped part of a hydraulic component which moves to direct flow through the component.

Sprocket: The driving element of the track mechanism. Receiving power through the drive mechanism, the sprocket meshes with the track to travel the crane.

Strainer: A filtering device for the removal of coarse solids from a fluid.

Stroke: The length of travel of a piston or spool.

Suction Line: The hydraulic line connecting the pump inlet port to the hydraulic reservoir.

Sump Tank: See "Hydraulic Reservoir".

Operator's Manual

Support Line: The cable reeved from second hoist drum for holding clamshell bucket suspended during dumping and lowering operations.

Surge: A very sudden rise in the hydraulic or air pressure or electrical potential in a circuit.

Swing: The rotation of the upper with the lower remaining stationary.

Swing Lock (Travel Swing Lock): A mechanical lock that engages with the upper in four positions only (directly over the ends or the sides of the lower). Use of the travel swing lock is mandatory when traveling, transporting, or lifting the crane and during pick and carry operations.

Swing (Park) Brake: A brake which is used to resist rotation of the upper in any position over the lower during normal, stationary crane operations.

Swing Motor: Hydraulic device which uses a planetary to rotate the upper on the lower.

System Override Switch: See "Rigging Switch".

Tagline: A wire rope or cable attached to the bucket and a spring loaded, counterweighted, or powered unit keeping it in tension to retard rotation and pendulum swaying of an otherwise freely suspended bucket.

Tailswing: The distance from the centerline of rotation of the upper frame to the extreme rear swing arc of the counterweight or most rearward component on the crane.

Third Drum: A third hoist drum, in addition to two main hoist drums, often used in pile driving.

Top Section: The upper most section of a lattice boom or jib which also contains the head machinery of the attachment.

Torque: Turning or twisting force usually measured in foot-pounds (ft lb) or Newton meters (Nm).

Track: Assembled track shoes and connecting pins around idler rollers and drive sprockets; that part of lower which contacts the ground.

Track Roller: Rollers of track mechanism which are not power driven, but are used to guide the track on the bottom of the side frame and along the ground.

Travel Swing Lock: A mechanical lock that engages with the upper in four positions only (directly over the ends or the sides of the lower). Use of the travel swing lock is mandatory when traveling, transporting, or lifting the crane and during pick and carry operations.

Tubular Jib: Multiple section lattice extensions supported by pendants and attached to the main boom head.

Turntable Bearing: A large bearing which attaches the upper frame to the lower frame allowing the upper to rotate on the lower.

Two Block: The condition when the crane's hook block, hook ball, any other load attachment means, or the load itself, comes into contact with any of the attachment's load sheaves or other physical entity on the attachment.

Two Block Warning System: A system of electromechanical devices used to warn the crane operator of an impending two block condition.

Upper: The portion of the crane located above the turntable bearing.

Upper Revolving Frame: The main structure of the upper section of the crane which serves as mounts for other components of the upper.

Upper Roller: See "Carrier Roller".

Valve: A device for controlling flow rate, flow direction, or pressure of a fluid.

Viscosity: The resistance to flow. High viscosity indicates a high resistance; low viscosity, a low resistance.

Wedge Pack: See "Shim Pack".

Whip Line: Secondary hoist line. Also see "Load Line".

Winch: Function of lifting and lowering loads.

Winch Drum: A rotating cylindrical spool with side flanges used to wrap the winch wire rope during the raising and lowering of the load with the winch.

Winch Rope (Winch Wire Rope): The wire rope used to reeve the winch and the attachments for lifting loads.

Wire Rope: A flexible, multiwired member usually consisting of a core member around which a number of multiwired strands are helically wrapped.

Wiring Diagram: A diagram which includes all the devices in an electrical system and shows their functional relationships to each other. Such a diagram gives the necessary information for physically tracing circuits when troubleshooting is necessary.

Working Weight: Weight of crane with full radiator, half full fuel tank, and attachments installed.

Operator's Manual

Notes:

Operator's Manual

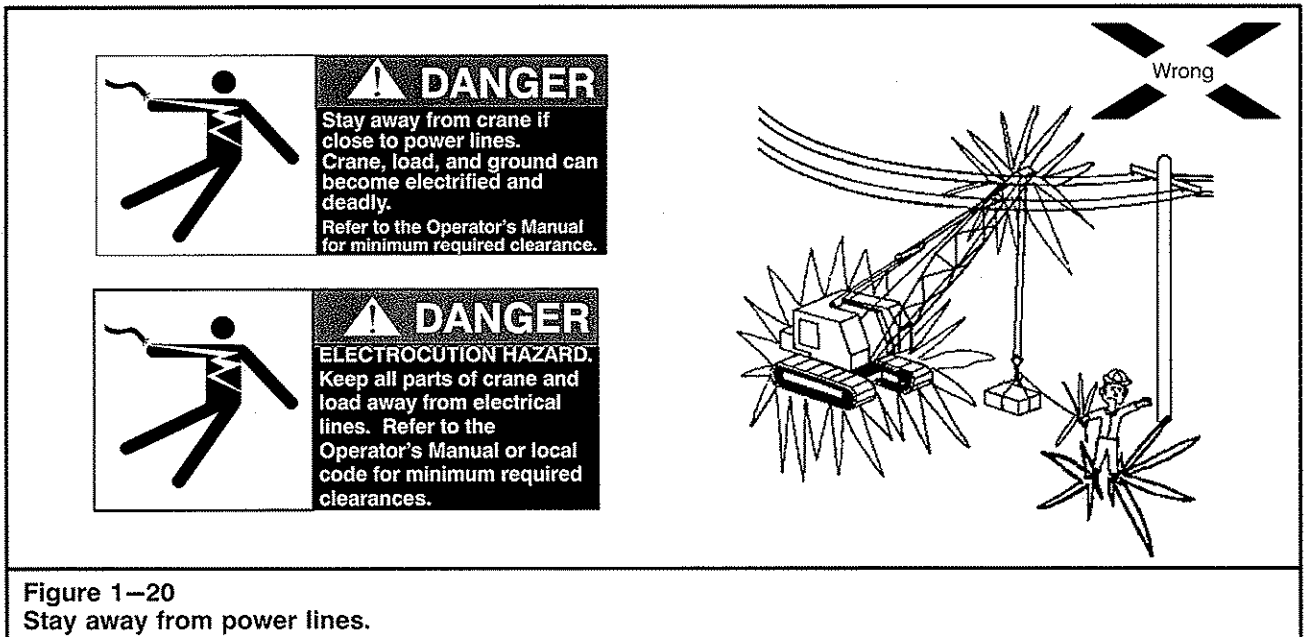

Figure 1-20
Stay away from power lines.

Electrical Dangers

1. All electrical power lines are dangerous. Contact with them, whether insulated or not, can cause death or injury. When operating near power lines, the best rule is to have the power company turn off the power and ground the lines. However, in some cases, the operator may be unable to have the power turned off. Follow these rules whether the power is turned off or not. Follow all requirements per OSHA regulation 1926.1410.
 - a. Be alert. You are working around conditions which can cause death.
 - b. Keep all parts of the crane, fall lines, hook block, hook ball, and load, at least the distance from power lines as specified in the "High Voltage Power Line Clearance Chart" or other distances specified by applicable codes, whichever is greatest. Slow down crane operation.
 - c. Assume that every line is electrically energized ("Hot" or "Live").
 - d. Appoint a reliable person equipped with a loud signal (whistle or horn) to warn the operator when any part of the crane is working around the power line. This person should have no other duties while the crane is working around the power line.
 - e. Do not perform any crane assembly/disassembly under any energized power line.
 - f. Erect a suitable barricade to physically restrain the crane and all attachments (including the load) from entering an unsafe distance from the power source.

Minimum Clearance When Operating Near High Voltage Power Lines Or During Crane Assembly/Disassembly	
Normal Voltage, kV (Phase to Phase)	Minimum Required Clearance, ft (m) See Note 1
To 200	15 (4.57)
Over 200 To 350	20 (6.10)
Over 350 To 500	25 (7.62)
Over 500 To 750	35 (10.67)
Over 750 To 1000	45 (13.72)
Over 1000	As established by the power line owner/operator or registered professional engineer who is a qualified person with respect to electrical power transmission and distribution.
Minimum Clearance When Traveling With No Load	
To 345	15 (4.57)
Over 345 To 750	16 (4.87)
Over 750 To 1000	20 (6.10)
Over 1000	As established by the power line owner/operator or registered professional engineer who is a qualified person with respect to electrical power transmission and distribution.
Note 1: Maintain 50 ft (15.2m) minimum clearance from power lines if voltage is unknown. If unknown but yet known to be less than 350 kV, maintain 20 ft (6.1m) minimum clearance.	
Note 2: Environmental conditions such as fog, smoke, or precipitation may require increased clearances.	
High Voltage Power Line Clearance Chart	

Operator's Manual

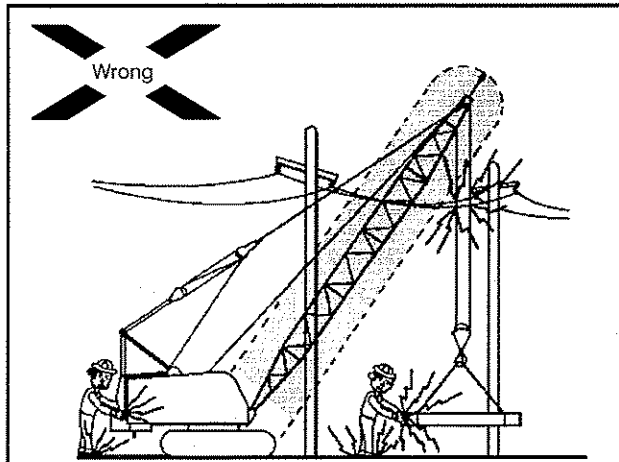

Shaded area shows "sensitivity zone" with full boom length sensor used. Contact can be made outside this zone by the hoist wire rope, winch wire rope, cab, etc. In such cases, the alarm will not sound, but the crane will be electrified and deadly.

Figure 1-21
Crane equipped with proximity warning device on the entire boom.

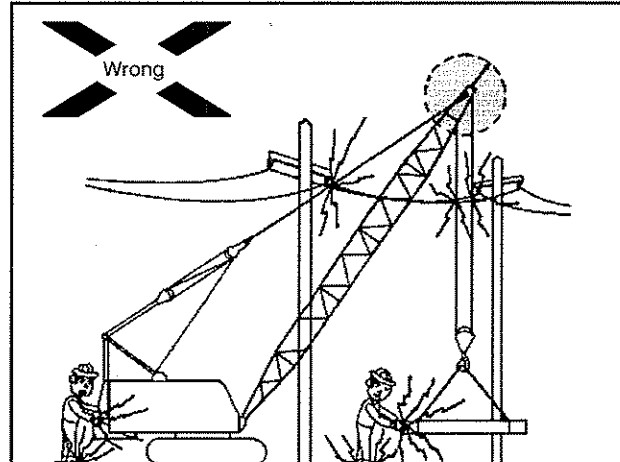

Shaded area shows "sensitivity zone" with the probe near the boom peak. Contact can be made outside this zone by the hoist wire rope, winch wire rope, cab, etc. In such cases, the alarm will not sound, but the crane will be electrified and deadly.

Figure 1-22
Crane equipped with proximity warning device on the boom tip.

- g. Warn all personnel of the potential danger. Don't allow unnecessary persons in the area. Don't allow anyone to lean against or touch the crane. Don't allow workers or load handlers to hold load lines, or rigging gear unless absolutely necessary. In these cases use dry plastic ropes as tether lines. Make certain everyone stays a minimum distance away from the load as specified in the "High Voltage Power Line Clearance Chart", or such distance as required by applicable codes, whichever is greatest.
 - h. The use of boom point guards, proximity devices, insulated hooks, or swing limit stops do not assure safety. Even if codes or regulations require the use of such devices, you must follow rules listed here. If you do not follow them, the result could be serious injury or death. Figure 1-21 through Figure 1-24 portray some of the limitations of the devices.
 - i. Grounding the crane can increase the danger. Poor grounding such as a pipe driven into the ground, will give little or no protection. In addition, a grounded crane may strike an arc so heavy that a live line may be burned down. This could cause the crane and the area around it to be electrified.
 - j. When operating near radio or T.V. transmitting stations, high voltage can be induced in metal parts of the crane, or in the load. This can occur even if the crane is some distance from the transmitter or antenna. Painful, dangerous shocks could occur. Contact trained electronic personnel before operating the crane to determine how to avoid electrical hazards.
 - k. Overhead lines can move when the wind blows against them. Allow for this when determining safe operating distances.
2. **What do you do if a power line is touched by a crane or load?**
 - a. Remain calm – think – a mistake can kill someone.
 - b. Warn all personnel to keep clear.
 - c. If crane will still operate, try to move it away from contact. You, the operator are reasonably safe in the cab unless the crane is on fire or an arc is cutting through the cab.
 - d. Move away from contact in the reverse direction to that which caused the contact. Example: If you swing left to the wire, swing to the right to break contact. Remember – once an arc has been struck, it will stretch out much farther than you think before it breaks. Keep moving until the arc has been broken.

Operator's Manual

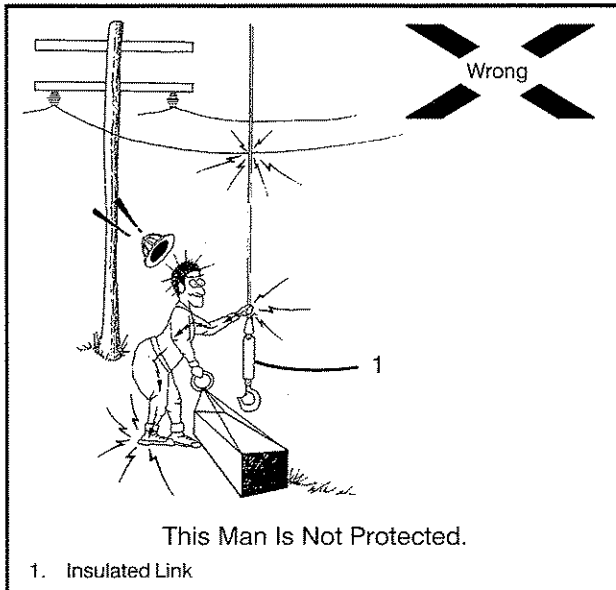

Figure 1-23
Crane equipped with insulated link.

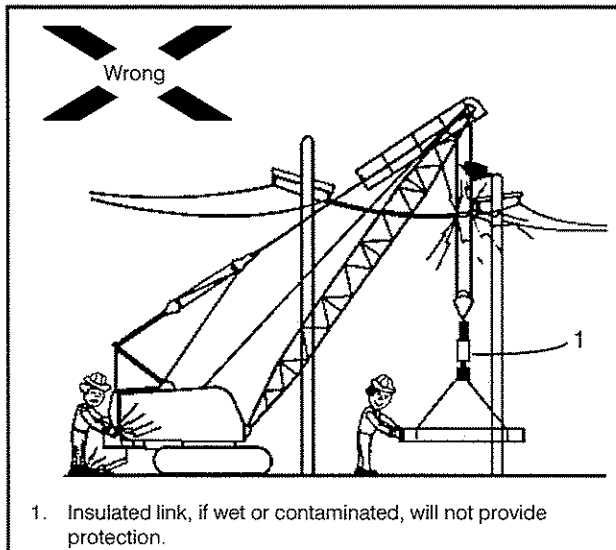

Figure 1-24
Crane equipped with insulated link and boom point guard.

- e. When the arc breaks, continue moving away until you are at least the minimum distance away as specified in the "High Voltage Power Line Clearance Chart" or as specified by local codes, whichever is greatest. Stop the crane. Make a thorough inspection for crane damage before further use. Contact your Link-Belt Distributor and request "Crane Inspection After Contacting Power Line" form which lists necessary inspection items.

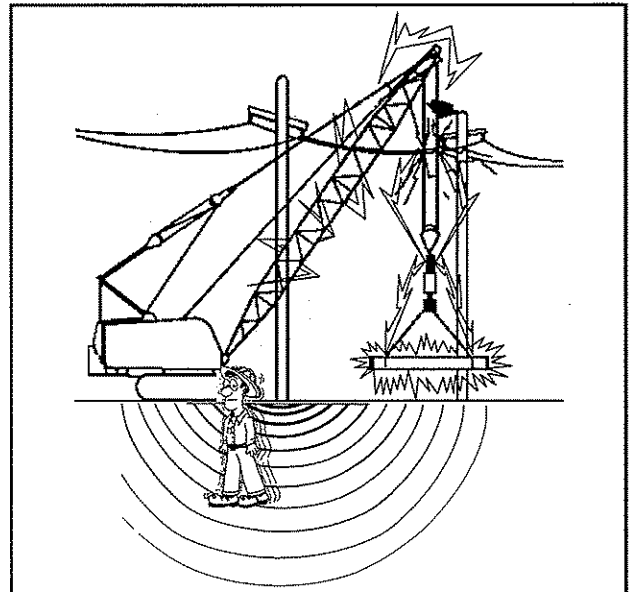

Figure 1-25
If you must leave the crane, do not step off. Leap as far as you can with feet together and hop or shuffle away from the crane.

- f. If you cannot disengage from the electrical line, and the crane is not on fire or no arc is cutting through the cab, stay in your seat until power line can be turned off.
 - g. If you must leave the crane, don't step off. Leap from the crane as far as you can, landing with feet together, then hop away from the crane with feet together, or shuffle feet to keep them close together. This could help prevent personal injury.
3. When using a magnet:
- a. Lifting magnet generators produce voltage in excess of 200 volts and present an electrical shock hazard. Only trained personnel should work on the magnet, controller, or wiring. Don't open the controller door with the generator running.
 - b. Do not let workmen touch magnet or load.
 - c. Do not let workmen get between magnet and a metal object.
 - d. If necessary to position a load, use a dry, wooden stick.
 - e. Open magnet disconnect switch at magnet control panel before connecting or disconnecting leads.

Operator's Manual

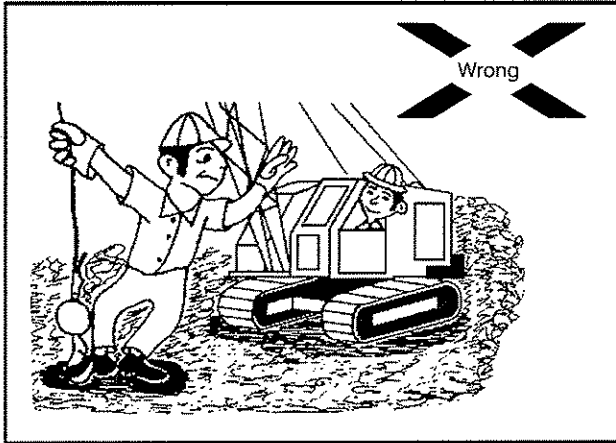

Figure 1-26
No hook riders!

Radio Frequency Or Electro Magnetic Interference (RFI Or EMI)

Certain areas may contain high Radio Frequency Or Electro Magnetic Interference (RFI or EMI). In these areas the boom can act like an antenna and produce an electrical current that may cause electrical shocks and/or the crane to malfunction. If operating in an area where these conditions may exist, test the crane or have the area tested for the magnitude of this interference before operating the crane. Operation may not be possible or boom length may be limited. Comply with all local, state, and federal laws when operating in high RFI/EMI areas.

Protective Equipment

1. Always replace protective guards and panels before operating the crane.
2. Always wear hard hats, safety glasses, steel toe shoes, hearing protection, and any other safety equipment required by local job conditions, OSHA, or regulations. Do not wear loose clothing which could get caught in moving machinery.
3. Always wear safety glasses when drilling, grinding, or hammering. Flying chips could injure the eyes.
4. Always wear a mask to prevent breathing any dust, smoke, fumes, etc. while cleaning, drilling, welding, grinding, sanding, etc. on any part of the crane. Breathing dust, smoke, fumes, etc. can be very hazardous.
5. Keep a dry chemical or carbon dioxide fire extinguisher of 5BC rating or larger in the cab or in the immediate area of the crane at all times. Instruct all operating and maintenance personnel in proper use of the extinguisher. Check periodically to ensure it is fully charged and in working order.

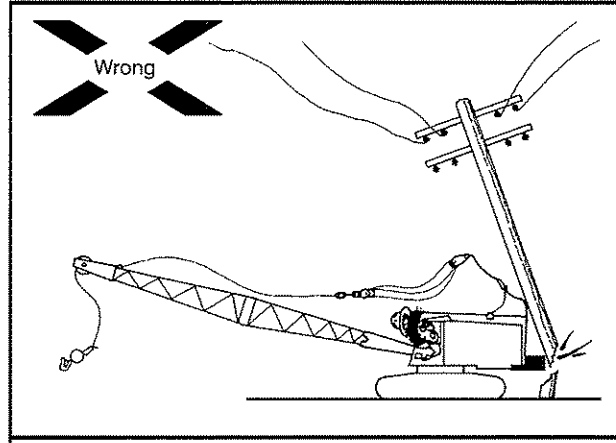

Figure 1-27
Use a signal person, back safely.

6. Do not tamper with safety devices. Keep them in good repair and properly adjusted. They were put on the crane for your protection.
7. When operating a crane equipped with any form of load indicating mechanism, overload warning system, anti-two block system, or any automatic safety device, remember that such devices cannot replace the skill and judgment of a good operator. For instance, such devices cannot tell when a crane is setting on a supporting surface that will give away, that too few parts of line are being used to lift a load, cannot correct for the effects of wind, warn that the device may be improperly adjusted, correct for side pulls on the boom, or for many conditions which could occur and create hazards. It requires all the skill, experience, judgment, and safety consciousness that a good operator can develop to attain safe operation. Many safety devices can assist the operator in performing his duties, but he should not rely on them to keep him out of trouble.

Signal Persons And Bystanders

1. Don't allow crane boom or loads to pass over people or endanger their safety. Remove all loose objects from load. All unnecessary personnel should leave the immediate area when crane is operating.
2. Do not allow anyone to ride on the hook block, hook ball, or any part of the load or attachment for construction work or recreational activities. (This applies to recreational activities such as "bungee jumping" or "bungee cord jumping".) Cranes are intended to lift objects, not people. They are not elevators.
3. Always look before you back up, or better yet, post a signal person to guide you. If crane is equipped with a back up alarm, ensure it is working properly. Use the horn as a signal. Use a code such as one beep – stop, two beeps – forward, and three beeps – backward. Ensure that everyone on the job site knows the code.

Operator's Manual

4. Do not make a lift which is not in plain sight. This can lead to an accident or crane damage. Post a signal person, if necessary, to fully observe the situation and guide the operator.
5. Do not carry passengers! There is only one seat and it is for the operator. Do not allow personnel to ride on the crane during operation or while traveling the crane. A fall from the crane can cause serious injury or death.

Crane Inspections And Adjustments

1. Inspect crane daily. Do not operate a damaged or poorly maintained crane. Pay particular attention to the clutches, brakes, attachments, and wire ropes. If a component is worn or damaged, replace it before operating. Clutch and brake linings must be dry and oil free. Oil soaked linings must be replaced.
2. Labels, plates, decals, etc. should be periodically inspected and cleaned as necessary to maintain good legibility for safe viewing. If any instruction, caution, warning, or danger labels, decals, or plates become lost, damaged, or unreadable, they must be replaced.
3. When performing repetitive lift applications, especially at or near maximum strength limited capacities, an inspection of the major structural areas of the crane, for cracks or other damage, should be conducted on a regular basis. (A non-destructive test such as magnetic particle or dye penetrant may even be considered.) Along with inspection for cracks and damage, frequently check the critically loaded fasteners, such as the turntable bearing mounting capscrews, to ensure they have not been stretched. Not only does frequent inspection promote safety, but it is also much easier and less expensive to perform a repair when a crack is small, before it has a chance to traverse through a structural member. Any sign of cracks or damage must be repaired before continuing operations. Contact your Link-Belt Distributor for repairs.
4. When performing maintenance on the crane, do the following:
 - a. Lower the boom to the ground.
 - b. Shutdown the engine and work all control levers back and forth to relieve pressure and relax the attachment.
 - c. If the above instructions cannot be followed, block securely under the attachment so it cannot move.
 - d. Bleed any precharge off the hydraulic reservoir before disconnecting any line.



Figure 1-28

Remove the keys from the ignition and post a sign to make others aware of repair activity.

- e. Hydraulic oil becomes hot during operation. In some cases it becomes hot enough to cause serious burns. Be careful not to let hydraulic oil come in contact with skin.
 - f. Disconnect battery cables and remove ignition key so crane can't be started. Post warning signs in the operator's cab so no one will try to start the engine. Never adjust, maintain, or repair a crane while it is in operation.
5. When making repairs, which require welding, use proper welding procedures. Also the following precautions must be taken:
 - a. All paint in the area should be removed to prevent burning the paint. The smoke and fumes from the burning paint can be very hazardous.
 - b. Disconnect the batteries.
 - c. The welding ground cable should be attached to the portion of the crane being welded. If welding on the upper, ground on the upper. If welding on the lower, ground on the lower. Failure to take this precaution may result in electrical arcs in the turntable bearing.
 - d. The welding ground cable should always be connected as close as possible to the area being welded. This minimizes the distance that electricity must travel.
 - e. Disconnect computers and other electronic equipment (such as load moment indicators) to prevent damage. Contact your Link-Belt Distributor or factory for proper procedures.
 - f. Remove all flammables from the proximity of the welding area.
 6. Keep the crane clean, in good repair, and in proper adjustment. Improper adjustments can lead to crane damage, load dropping, or other malfunctions.

Operator's Manual



Figure 1-29
Allow engine to cool before removing the radiator cap.

7. Keep all walking surfaces (steps, ladders, platforms, etc.) on the crane clean. They are on the crane to assist operators and service personnel with safe access/egress to/from the crane and to/from adjustment and inspection areas.
8. Use extreme caution when removing radiator caps, hydraulic pressure caps, etc. They can fly off and hit you, or you could be burned by hot oil, water, or steam.

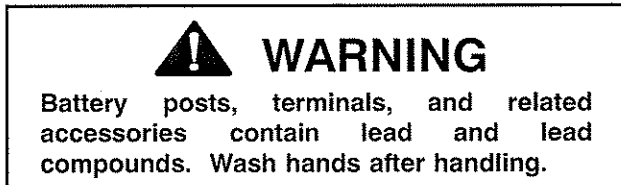

9. When checking battery fluid level, use a flashlight, not an open flame. If the battery explodes, you can get acid in your eyes, which could cause blindness. Don't check battery charge by shorting across posts. The resulting spark could cause the battery to explode. Check with a tester or hydrometer. Don't smoke near batteries.
10. When using jumper cables to start an engine, always connect negative post to negative post, and positive post to positive post. Always connect the two positive posts first. Then make one negative post connection. Make the final negative connection a safe distance from the battery. It can be made on almost any bare metal spot on the crane. Any spark could cause the battery to explode.

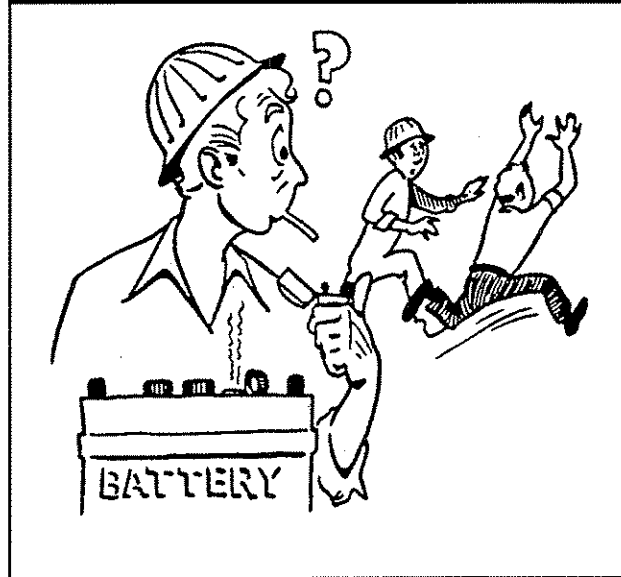

Figure 1-30
Do not use an open flame near the battery.

11. Test the winch brake by raising the load a few inches (*cm*) and holding. It should hold without slipping. It takes more braking power to hold a load in the air when the drum is full of wire rope than when it is a few inches (*cm*) above the ground with only a few wraps on the drum.
12. Always reduce pressure in hydraulic system to zero before working on any part of the system. Pin sized and smaller streams of hydraulic oil under pressure can penetrate the skin and result in serious infections. So not use your hands to check for leaks. If hydraulic oil does penetrate the skin, seek medical treatment immediately.
13. Use extreme care when working on circuits with accumulators. Check that hydraulic pressure is relieved before opening the circuit for repairs.
14. When setting pressures, never exceed the manufacturer's ratings. Always follow instructions exactly. Over pressurization can cause hydraulic component damage or failure of mechanical parts on the crane. Either of the above can lead to an accident.

Wire Rope

1. Inspect all wire rope thoroughly. OSHA (Occupational Safety And Health Act) regulations state "a thorough inspection of all wire ropes shall be made once a day and a full written, dated, and signed report of the wire rope condition be kept on file where readily available." Replace any worn or damaged wire rope. Pay particular attention to winch wire ropes. Check end connections (pins, sockets, wedges, etc.) for wear or damage.

Operator's Manual

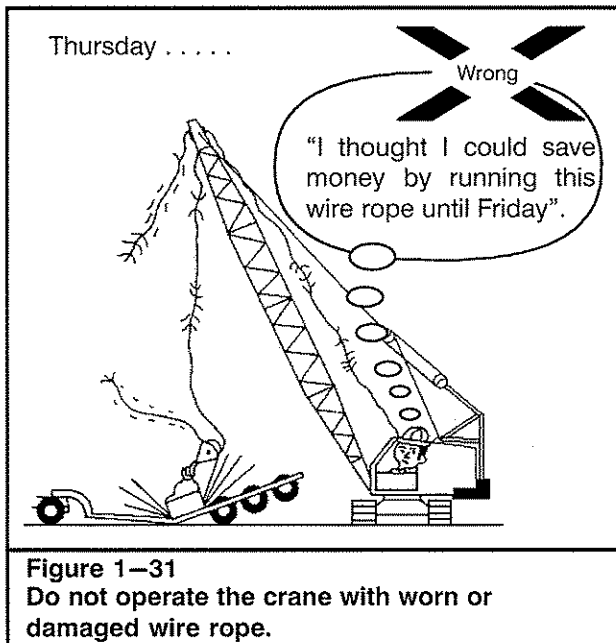

2. Non-rotating, rotation resistant, or spin resistant wire ropes are recommended for single part of line applications. This is of utmost importance for long fall hoist line applications. Only if certain criteria are met may a swivel hook ball be used with rotation resistant wire rope. Refer to "Single Part Line Hoisting" and "Hook Ball Usage With Rotation Resistant Wire Rope" in Section 5 of this Operator's Manual.
3. Use at least the number or parts of winch line specified on the Wire Rope Capacity Chart in the Crane Rating Manual to handle the load. Local codes may require more parts of line than is shown. Check code requirements and use them where applicable.
4. Do not handle wire rope with bare hands. Always use gloves to prevent possible injury from frayed or damaged areas in the wire rope.
5. Inspect head machinery and hook block often, as damaged or deteriorating sheaves can cause excessive wear on the wire rope.
6. When reeving wire rope on the crane, do not climb, stand, or walk on the boom or jib. Use a ladder or similar device to reach necessary areas.
7. Use caution when disconnecting the dead end of wire ropes. Reeved wire rope can become twisted on the sheaves. When the dead end pin or socket is removed the wire rope may spin.

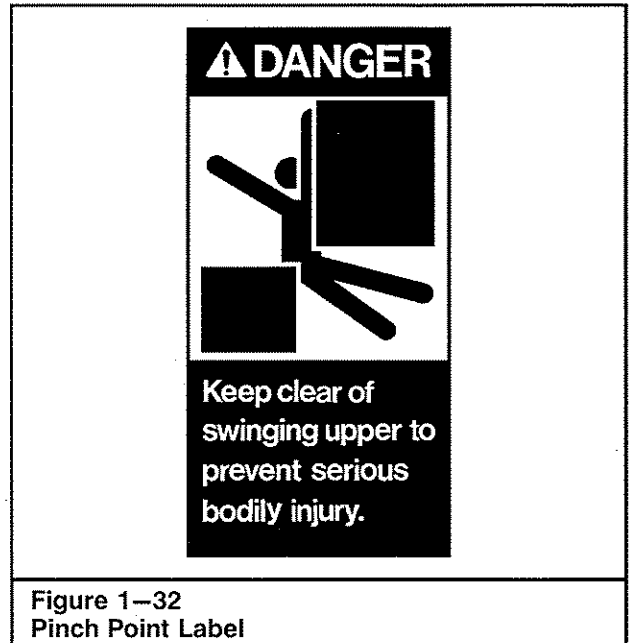

Crane And Area Clearance

1. Know your job site conditions. Familiarize yourself with work site obstructions and other potential hazards in the area which might lead to mishaps. Make any necessary arrangements to eliminate any potential hazards, if possible.
2. Erect barricades around the immediate work area to prevent unauthorized personnel from wandering onto the job site.
3. Confirm that your work area is clear. Ensure you have proper clearance for the crane, boom, and load. Don't swing, travel, lift, or lower loads, raise or lower jacks, without first making sure no one is in the way. If your vision is obscured, locate a signal person so you can see him, and he can see all areas you can't. Follow his signals. Ensure you and the signal person understand each other's signals. See Hand Signal Chart in Figure 1-84. Use the horn to signal or warn. Ensure everyone on the job site understands signals before starting operations.
4. When working inside a building, check overhead clearance to avoid a collision. Check load limits on floors or ramps so you won't crash through.
5. Don't operate close to an overhang or deep ditch. Avoid falling rocks, slides, etc. Don't park crane where a bank can fall on it, or it can fall in an excavation. Don't park where rain can wash out footing.
6. Pinch points, which result from relative motion between mechanical parts, can cause injury. Keep clear of the rotating upper or moving parts.

1
2
3
4
5
6
7
8
9
10
11
12
13
14
15
16
17
18
19
20
21
22
23
24
25
26
27
28
29
30
31
32
33
34
35
36
37
38
39
40
41
42
43
44
45
46
47
48
49
50
51
52
53
54
55
56
57
58
59
60
61
62
63
64
65
66
67
68
69
70
71
72
73
74
75
76
77
78
79
80
81
82
83
84
85
86
87
88
89
90
91
92
93
94
95
96
97
98
99
100

[Faint, illegible text on lined paper]

NOTES

NOTES

Operator's Manual

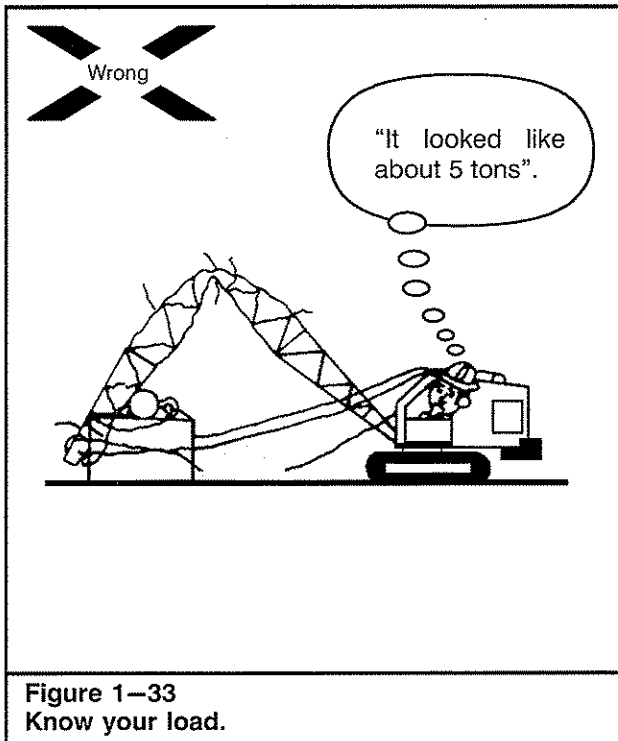

Figure 1-33
Know your load.

7. Watch the tailswing of the upper revolving frame and counterweight. Even though the original setup may have been clear, situations change.
8. Do not store material under or near electrical power sources. Make material handlers aware of the dangers involved with storing material under power lines or in the vicinity of any other hazards.

Weights, Lengths, And Radii

1. Know your load. Don't try to guess or estimate the load. Use a scale or a load indicating system to determine exact weight. Remember the weight you are lifting includes the weight of any lifting slings or gear, the hook block, hook ball and any other weight on the hook. If lifting off the boom with the jib installed, the weight of the jib and rigging must also be considered as part of the load. Refer to the capacity deductions chart in the Crane Rating Manual for amounts to be deducted.

The total load weight must never exceed the rated capacity of the crane, as listed on the capacity charts in the Crane Rating Manual for the position, boom length, load radius, and condition of operation being used. Remember — the rating listed on the capacity charts in the Crane Rating Manual are based on ideal conditions:

- a. Standing on firm, level surface.
- b. Calm wind.
- c. No side loads or out swing of load.
- d. Good visibility.

- e. Crane in top condition and equipped as when leaving the factory.

When such conditions cannot be attained, loads being handled must be reduced to compensate. The amount loads are reduced depends upon how good or how poor, the actual operating conditions are. It is a matter of judgment and experience. When in doubt, do not take a chance. Reduce ratings more than you think you need. Some factors which may require reduction of capacities are:

- a. Soft or unpredictable supporting surfaces.
- b. Wind.
- c. Hazardous surroundings.
- d. Inexperienced personnel.
- e. Poor visibility.
- f. Fragile loads.
- g. Crane in poor condition.

When lifting loads with large surface areas, such as building panels, in a wind, the movement of the load may pose a danger to workers or building structures. Out swing of a load will increase the load radius, and may overload the crane. This could lead to boom failure or the crane tipping.

2. Avoid working a crane in high winds. If you must work in a wind, reduce capacities considerably below those shown on the capacity chart in the Crane Rating Manual. Wind blowing against the load and the boom produces a side load on the boom and reduces its capacity. Refer to "Wind Restrictions Guide" in the Crane Rating Manual.
3. When operating off the main boom with the jib or other attachment erected, deductions must be made for its weight. The weight of the added attachment, pendants, etc., must be considered to obtain a "NET" capacity. Failure to do so could result in an overloading condition and cause boom failure. Refer to the capacity deductions chart in the Crane Rating Manual for amounts to be deducted.
4. Do not lift two loads at the same time, even if the total load weight is within crane capacity. Loads on the boom and jib at the same time, stress the boom and drastically reduce its ability to handle loads. Your full attention cannot be given to both loads, creating a dangerous situation.
5. Some capacities on cranes are based on strength of materials. In these cases, overloads will cause something on the crane to break, before it will tip. Do not use signs of tipping as a warning of overload.
6. Don't lash a crane down. Lashing a crane down encourages overloading. Crane damage or injury could result.

Operator's Manual

7. Do not shock load and/or overload the crane at anytime. Shock loading or overloading the crane will reduce the fatigue life of crane components and could result in component failure.
8. When performing repetitive lift applications, especially at or near maximum strength limited capacities, be aware that these applications may reduce component life. These applications include repeated lifting (or lifting and swinging) of near 100% strength limited capacities and repeated lifting maximum moment loads. These applications may fatigue the major structural portions of the crane. Although the crane may not break during these applications, they can reduce the fatigue life and shorten the service life of the crane. To improve the service life, while performing repetitive lift applications, consider reducing the capacities to 70% of maximum strength limited capacities to reduce fatigue cracking. Frequently perform a thorough inspection of all the structural areas of the crane. Any sign of cracks or damage must be repaired before continuing operations. Contact your Link-Belt Distributor for repairs.
9. Always refer to the appropriate capacity chart in the Crane Rating Manual after changing the arrangement of the attachments for the correct lifting capacities.
10. All booms must be assembled in the correct manner before making a lift. The capacity charts in the Crane Rating Manual for such booms are based on proper boom make-up. Correct placement of boom extensions, based on length is crucial. Refer to the "Suggested Boom Make-Up Chart" in Section 4 of this Operator's Manual for correct boom section arrangements.
11. Do not use the boom to push or pull. It is not designed for this purpose. Such action can damage the boom and lead to an accident.
12. Know the load radius. Don't guess at it. Determine the load radius by using the boom angle indicator, the boom length, and the capacity charts in the Crane Rating Manual, or measure it with a steel tape. Remember — Radius is the horizontal distance from the centerline of rotation of the upper to the center of gravity of the load, when the load is hanging free.

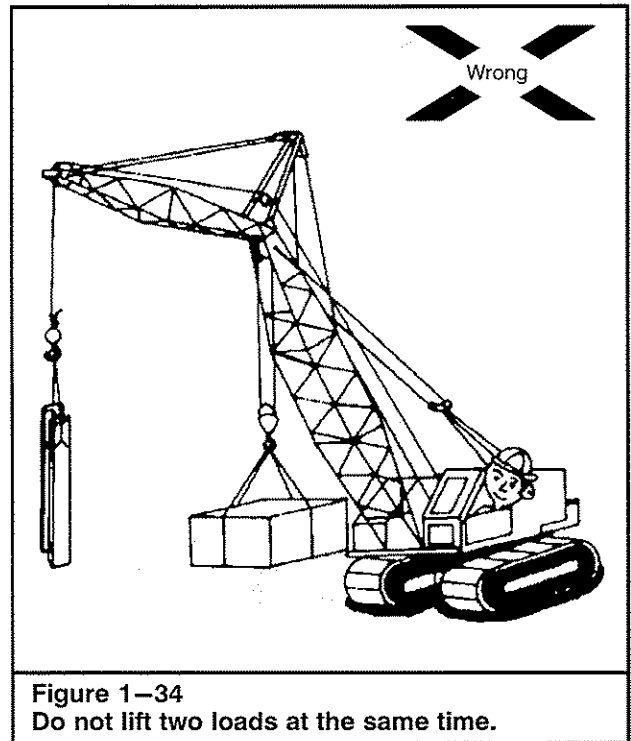

13. Do not operate the crane at radii or lengths where the capacity charts in the Crane Rating Manual show no capacity. Don't use a boom or jib not shipped with or for your crane. Either of the above can tip the crane over or cause attachment failure. In some cases, the crane can tip over forward or backward with no load on the hook! Also, if the boom is long at a low angle, the crane may tip until the boom touches the ground. In any of these cases, injury or crane damage could result.
14. When you lift a load with any crane, the load may swing out or sideways. The load radius will increase. The increase or out swing of the load can overload the boom, and lead to boom failure or tipping. Also, movement of the load can cause it to hit something. Ensure the load being lifted will remain within capacity as it is lifted and the boom deflects.
15. When lowering a boom with a load, the load radius increases. As the load radius increases, capacity decreases. If capacity is exceeded, the boom may bend or the crane may tip. Sometimes at low angles, the boom can be lowered with a load, but cannot be raised. If an operator lowers the boom under load, he may not be able to raise the boom and may get into a dangerous situation.

Operator's Manual

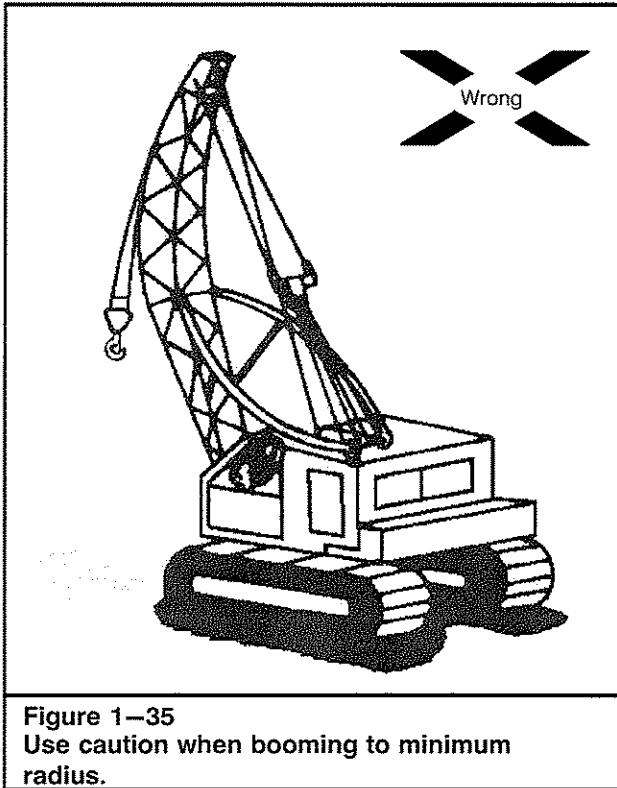

16. Use caution when booming up to minimum radius. Be prepared to stop boom travel. If the boom limit device malfunctions, the boom and backstops may be damaged, or someone may be hurt. Do not intentionally boom into boom limit device during normal operation.
17. When operating near minimum radius, be ready to boom down as you set the load down, to compensate for the tendency of the boom to move back against the backstops when the load is released. This action occurs because of the elasticity in the boom and boom hoist system. Major bending in the boom can occur if it is allowed to bear against the backstops too heavily.

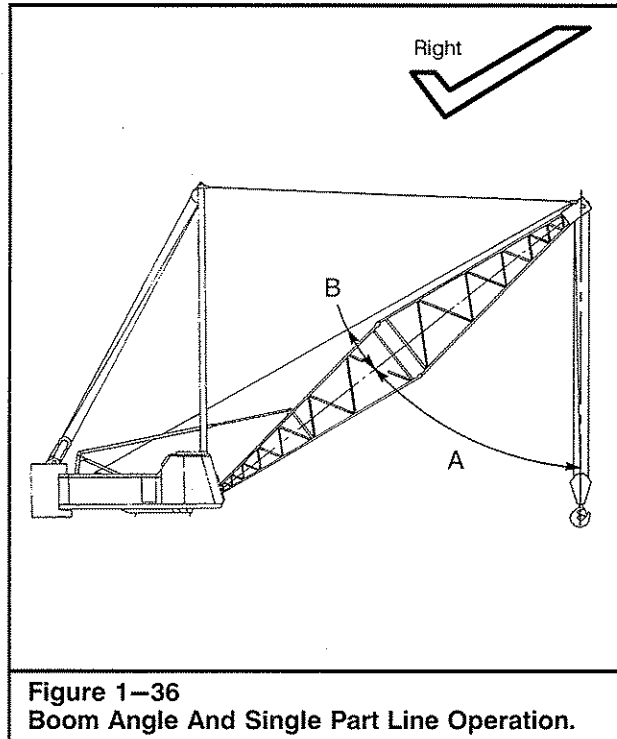

18. When booming down, the load will move away from the crane and lower as well. To keep the load from lowering as it moves away from the crane, the operator must hoist up on the winch wire rope simultaneously. When booming up, the load will move toward the crane as well as raise. When booming up, the operator must hoist down as well to keep from raising the load. Booming up without winching down, can lead to "two blocking". This is when the hook block, hook ball, or load contacts the head machinery. Two blocking can lead to sheave or wire rope damage.
19. Know the boom length. Don't guess. Use of an incorrect boom length can cause an accident.
20. Use special care when handling loads on single part line with boom at or near minimum radius. In single line operation, ensure angle "A" is always greater than angle "B", or the boom could fall backwards uncontrollably. Refer to Figure 1-36. This situation is more likely when the winch line is off the rear drum. Four (4) parts of hoist line and a hook block must be used at or near minimum radius on all booms 100 ft (30.5m) or less.

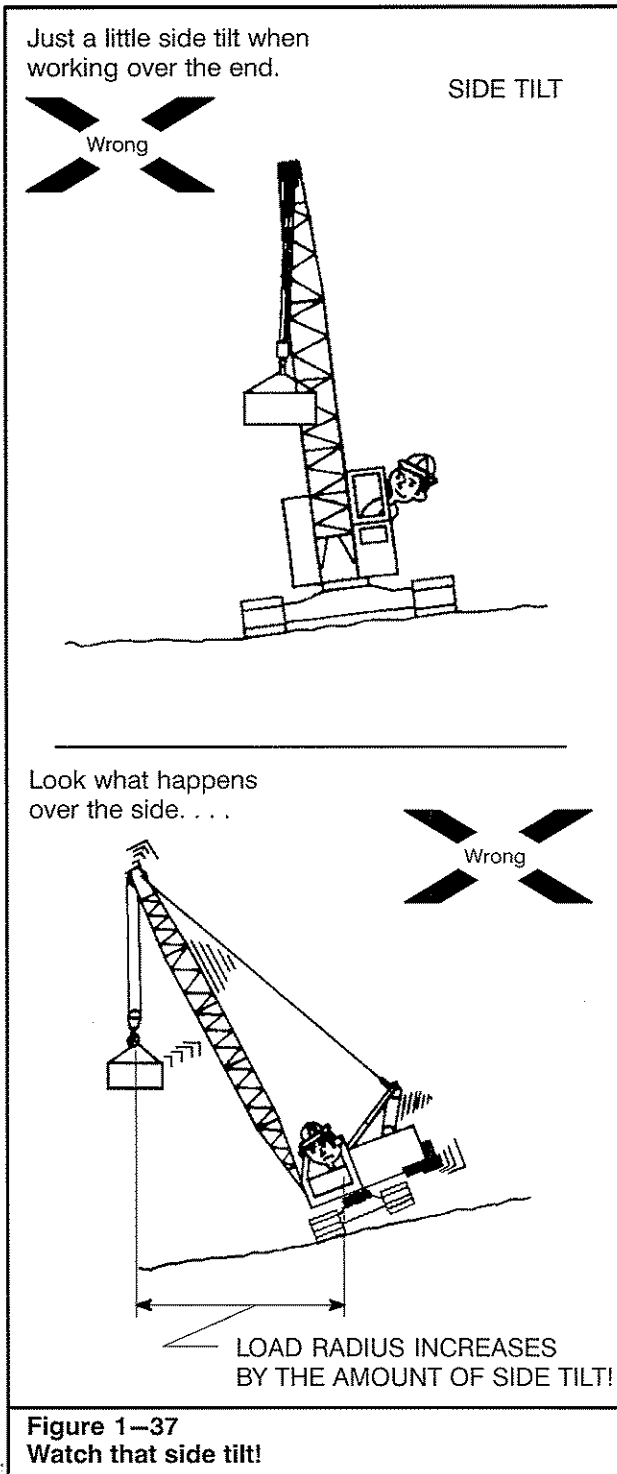

21. The winch wire rope must be vertical when starting to lift. If not, the load will swing in, out, or sideways when lifted from the ground. The crane will lean toward the load when lifting heavy loads. This is caused by elasticity of the crane and the boom.

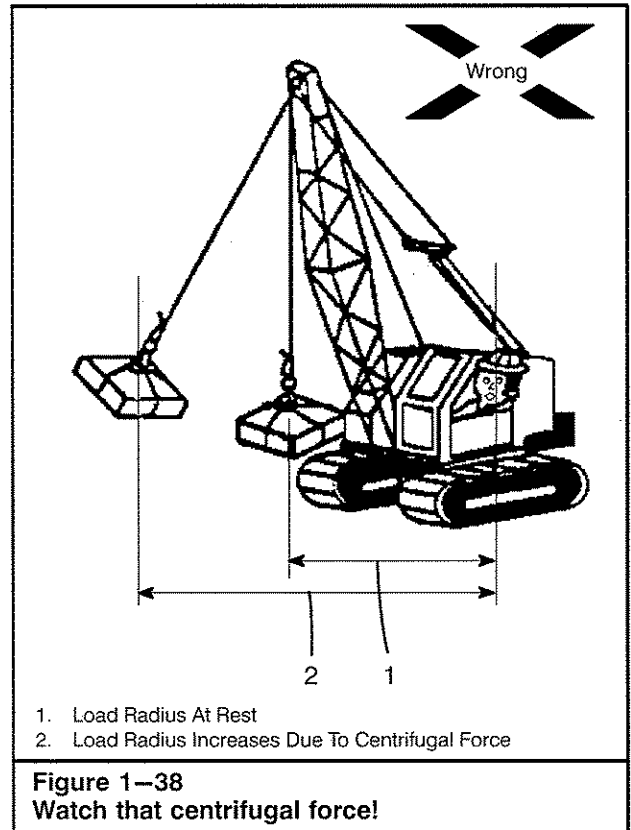

This lean will increase operating radius so the load will swing outward when it clears the ground. This out swing is dangerous to anything in the path of the load, and because of the increase in load radius may overload the crane. To overcome this out swing, boom up as the load is lifted so winch wire ropes remain vertical. When setting the load on the ground, lower boom after the load touches down to avoid hook block or hook ball spinning when it is unhooked from load, or the boom contacting the backstops.

22. Lifting heavy loads can cause the crane to tilt or lean toward the load. When swinging a load from over the end to over the side, the tilt of the crane will increase. Since tilt acts to increase load radius, it must be compensated for when swinging the load. Swing slowly. Change boom angle (raise the boom) while swinging, to maintain a constant radius, and prevent in swing or out swing of load. If not, a dangerous condition could result.
23. Watch out for centrifugal force when swinging a load. Swing gently. Centrifugal force tends to increase load radius. This increase in radius could overload the crane and cause crane damage or tipping. When stopping the swing, over swing of the load can side load the boom.

Operator's Manual

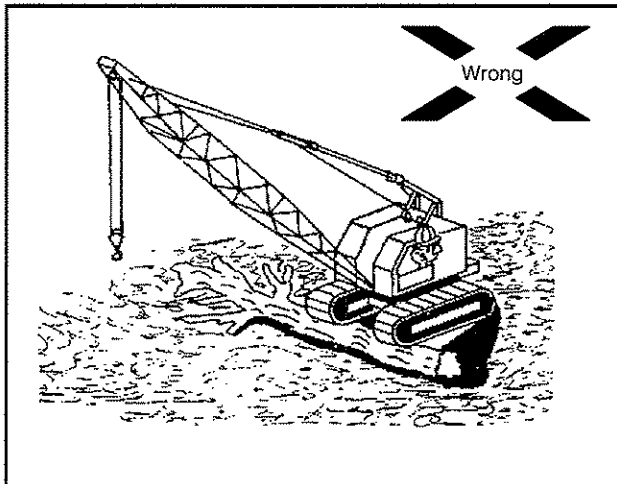

Figure 1-39
If possible, go around obstacles.

24. Keep the winch wire ropes as short as possible to prevent excessive swinging. Always use the shortest boom length which will do the job. Remember – the shorter the boom, the better the capacity.
25. Do not move a crane away from the load while handling near capacity loads. Due to load inertia (weight) the load will tend to stay in position when the crane starts to move, and then will swing in towards the crane. The inertia effect will tend to increase load radius and decrease stability. This could lead to boom failure or crane tipping.
26. Know how much counterweight is on the crane. The capacity charts in The Crane Rating Manual may list different capacities for differing amounts of counterweight. Confirm as to how the crane is equipped and use the correct column on the chart to ensure proper load limitations.

Don't modify the counterweight(s). Don't store anything on the crane that will act as additional counterweight. Remember that anything which has weight, if carried behind the crane's center of gravity, acts as counterweight. Adding counterweight affects backward stability of the crane, particularly when working over the side. It also encourages overloading of the crane.
27. Working areas for cranes are defined per the Working Areas diagram in the Crane Rating Manual. Permissible loads, per the Crane Rating Manual, may vary from lifting quadrant to lifting quadrant. The operator must ensure capacity ratings are not exceeded regardless of which quadrant he is operating in, or when swinging from one quadrant to another.

Traveling

1. Avoid traveling over obstacles: rough terrain, rocks, logs, curbs, ditches, etc. The size and type of obstacle that can be safely crossed will depend on many factors, including good judgment. When obstructions must be crossed, do so with extreme caution, at an angle if possible, and at slow speed. Ease up to the break over point, balance on the obstruction, and then ease down to minimize jolt of contact of the other side.
2. Cross a gully or ditch at an angle and very slowly. Carry boom at a low angle for increased stability.
3. Avoid side-hill travel whenever possible. Travel up or down the slope. Shift crane to lowest speed when starting up or down the slope. Keep the boom facing downhill and close to the ground. Traveling up the hill with the boom at a high angle should be avoided. Depending upon the slope of the grade, the angle may be such as to allow the boom to fall backwards over the lower. If the crane starts slipping sideways on a grade, immediately turn the crane down the grade.
4. When moving the crane around on the job site with the attachment in the air, observe the following precautions:
 - a. Swing upper so it is in line with tracks over front or rear of the lower. Engage the swing lock.
 - b. Terrain must be smooth and solid. If not, grade the area before moving the crane.
 - c. Tie down the hook block and/or the hook ball to prevent them from swinging when moving.
 - d. Boom must be at minimum radius, approximately 80°, unless you are traveling up or down a grade. In this case a lower boom angle is the more stable condition.
 - e. Position a signal person to guide you.
 - f. Avoid traveling on a grade, particularly a side slope. If you must travel up a slope, back up the grade for maximum crane stability and minimum side loadings.
5. Traveling with a suspended load should be avoided if possible. It is especially hazardous when terrain is rough or irregular, on a side slope, or in a hilly area. When traveling with a load, observe the following rules:
 - a. Use a hand line to control the load and reduce load swing.
 - b. Travel by the smoothest, most level route. If a smooth, level route is not available, don't travel with a suspended load. Grade the route to provide a smooth, level path. If it is not possible to grade the route, move the load by stepping.

Operator's Manual

Level the crane, lift the load, and set it down ahead of the crane. Travel the unloaded crane beyond the load, level the crane, lift the load, swing, and set it down farther along the route. Continue this procedure until the load is at its destination.

- c. Carry loads as close to the ground as possible.
 - d. Do not allow side swing of the load.
 - e. Don't attempt to carry loads which exceed the crane's rating as listed in the Crane Rating Manual.
 - f. Use a signal person to warn of any danger or obstruction along the route being traveled.
 - g. Don't travel with a load on soft ground. If the crane sinks into the ground, stability can be affected to the point of tipping the crane.
 - h. Keep all personnel clear of crane and load. Be prepared to set load down quickly at any time.
6. When transporting the crane, note the following:
- a. Operate with lights on. Use proper warning signs, flags, and other devices. Use an escort service if required.
 - b. Engage travel swing lock.
 - c. Remove or restrain the hook block and/or hook ball.
 - d. Check for maximum allowable travel speed, maximum amount of boom that can be transported, and any other travel limitations. Don't exceed these maximums. Crane damage or an accident could result.
 - e. Watch for narrow bridges and low clearances.
 - f. Check load limits, heights, width, and length restrictions in the area you are traveling.
 - g. Ensure your crane complies with all regulations.

Leaving The Station

1. Do not get on or off a crane in motion. Use both hands when climbing on or off the crane. If a ladder is provided, use it. Remain in three point contact with the crane at all times (two hands and one foot or two feet and one hand).

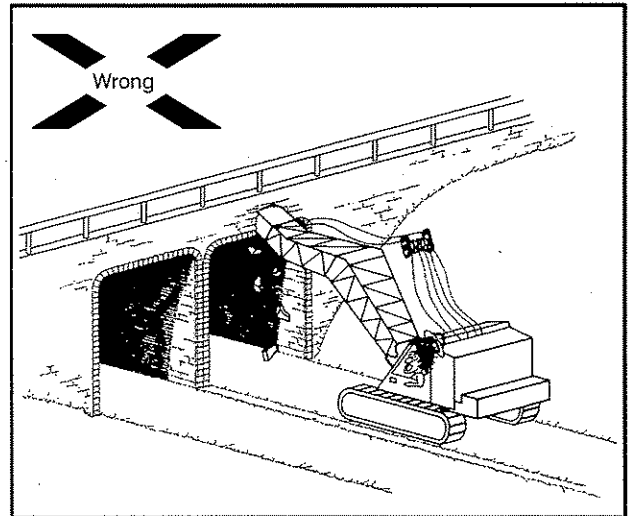

Figure 1-40
Watch for narrow or low clearances.

2. Whenever an operator leaves the control station for any reason, the following must be done:
 - a. Lower the load to the ground.
 - b. Engage the swing lock, engage all drum pawls, and move the control lockout switch to the off position. Shutdown the engine and remove the keys.
 - c. Do not depend on a brake to suspend a load unless the operator is at the controls, alert, and ready to handle the load. Brake pedal locks are intended to allow the operator to rest his legs when suspending a load, but the operator must remain in his seat with his feet on the pedals. Brake slippage, vandalism, or mechanical malfunctions could cause the load to drop.
3. Do not leave crane unattended with engine running.
4. When changing work shifts always notify the next operator of any changes or problems with the crane.

Operator's Manual

Personnel Handling Guidelines

Introduction

The following information is intended to provide Link-Belt's recommended minimum requirements that must be followed when handling personnel with a personnel basket or work platform (hereafter referred to as a work platform) suspended by wire rope from the boom of Link-Belt cranes. These requirements are based upon several sources and are put forth in recognition of current industry practices. However, safety, when handling personnel, remains the full responsibility of job site management and is dependent upon the responsible action of every person on the job involved in the related work.

This information is intended to supplement and not to supersede or replace any more restrictive federal, state, or local regulations, safety codes, or insurance requirements. It is intended to serve users of personnel work platforms in achieving the following objectives.

1. Reduce risk of personal injuries to users and the public.
2. Inform users of their respective responsibilities.
3. Provide standards of equipment requirements.
4. Provide standards for tests and inspections.
5. Provide standards of operation to promote safety.

Link-Belt cranes are designed and intended for handling material. They are not normally equipped with secondary systems or other devices required by personnel lift or elevator standards and are not intended for handling personnel for construction or amusement purposes. Use of cranes for these purposes is hazardous and is not recommended by Link-Belt. However, Link-Belt understands that circumstances may occur (in construction work) when lifting or lowering personnel on a materials handling crane load line is the only or the least hazardous method available to position personnel. In fact, Occupational Safety and Health Administration (OSHA) Part 29, CFR 1926.1431 states "The use of equipment to hoist employees is prohibited except where the employer demonstrates that the erection, use, and dismantling of conventional means of reaching the work area, such as personnel hoist, ladder, stairway, aerial lift, elevating work platform, or scaffold, would be more hazardous, or is not possible because of the project's structural design or worksite conditions."

Much corollary and supplementary information is contained within the following resource documents pertaining to both cranes and personnel work platforms. Job site management must ensure all requirements listed in these resource documents are followed for all personnel handling operations.

- American National Standards Institute Reference – ANSI Standards A10.28, A92.2, A92.3, B30.5, and B30.23.
- Power Crane and Shovel Association (PCSA) Bureau of the Association of Equipment Manufacturers (AEM) Reference – PCSA Standard No. 4.
- American Petroleum Institute (A.P.I.) Specification 2C.

- OSHA Part 29, CFR 1926.1431 Cranes and Derricks.

Authorization

Authorized use of a work platform may be permitted only after the following on-site procedures have been performed:

1. A competent person on the job site (job site manager) specifically responsible for the overall work function to be performed has determined that there is no practical alternative means to perform the needed work and has authorized a personnel lifting operation.
2. For each instance of such lifting, a competent person responsible for the task has attested to the need for the operation by issuing a written statement describing the operation and its time frame and itemizing that each of the on-site authorization requirements has been met. The written statement, after being approved by a qualified person, shall be retained at the job site. (Refer to *Personnel Handling Pre-Lift Check List For Link-Belt Cranes* in this Section for a sample check list.)
3. Review of crane inspection records has been conducted to ensure the crane being used meets applicable provisions in ANSI B30.5 and B30.23.
4. Review of the work platform inspection records and specifications has been conducted to ensure it meets applicable design standards (refer to ANSI A10-28).
5. Review of the personnel lifting operation practices specified in these instructions have been conducted with job site managers and crane operator(s), foreman, designated signal person, personnel to be lifted, safety supervisor, and any other person(s) who has jurisdiction over the operation to ensure that they are aware of the hazards of the operation and they are aware of provisions of these instructions that must be adhered to before and during the personnel lifting operation.

Equipment

1. The crane system shall be equipped with the following:
 - a. A fully functional working operational aid such as a Rated Capacity Limiter (RCL) system – A system consisting of devices that sense crane loading, boom length (extendable booms only), boom angle, and also automatically provide an audible/visual signal when the loading conditions approach, reach, and/or exceed the rated capacity values. When the Actual Load exceeds the Rated Capacity, the system supplies a signal to a function cutout system. The operational aid shall be equipped with these additional devices:
 1. Anti-two block device to prevent damage to the hoist wire rope, other crane components, or attachments, and subsequent endangerment of personnel.

Operator's Manual

- It is required that the anti-two block device warn both audibly and visually as well as have the capability to cutout the controls/functions that may cause a two block condition.
2. Boom angle indicator.
 - Cranes with extendable booms must utilize a boom angle indicator having "high and low" set points and audible/visual alarm(s) capable of activating function cutouts.
 - b. Boom hoist and load line shall have power lowering and raising and shall have an automatic brake which is applied when the applicable control is in neutral, or when the anti-two block device is actuated.
 - c. If the crane is equipped with a "free-fall" hoist, steps shall be taken to ensure its use is not possible during the use of the work platform. (Note: A.P.I. applications do not permit the crane to be equipped with free-fall.)
 - d. Each crane shall have a mechanical swing park brake or swing lock capable of being set at any swing position, and shall have a variable swing brake or swing controls capable of stopping the upper swing motion smoothly. The swing brake must be properly maintained at all times to ensure its holding capability.
- Note: All operational aids and equipment must be maintained in operable condition. Alternative measures are not permitted.**
2. The work platform shall be designed by a qualified engineer competent in structural design. Its maintenance, and its attachment to the crane load line, is the responsibility of the job site management. Their arrangement shall comply with the following as a minimum:
 - a. The work platform harness must be of sufficient length to prevent any portion of the work platform or the harness from coming in contact with the boom at any working boom angle.
 - b. Audible and visual alert systems shall be provided to the personnel in the work platform to signal for assistance in the event of an emergency.
 - c. Hooks on hook block assemblies, hook ball assemblies, or other assemblies, shall be of a type that can be closed and locked, (with a working safety latch) eliminating the hook

- throat opening, and shall be full load-bearing, and contain a manual trigger release.
3. No unauthorized alterations or modifications are allowed to be made to the basic crane.

Maintenance, Lubrication, And Adjustments

1. The crane operator must have a complete understanding of the crane's maintenance, lubrication, and adjustment instructions as outlined in this Operator's Manual.
2. The crane shall be maintained, lubricated, and adjusted, by a designated person, as specified in this Operator's Manual.
3. The crane and work platform decals must be understood and maintained.
4. All decal precautions and instructions shall be strictly observed.

Inspection And Rigging

1. The lift crane and work platform shall be inspected immediately prior to commencement of operation. (Refer to the Crane Operator's Manual and ANSI B30.5, Section 5, Section 5-2.1.2 and 5.2.4, and ANSI B30.23 for the required inspection procedures for the crane. Refer to ANSI A10-28 for inspection procedures required for the work platform.)
2. The inspection shall be performed once daily when the crane is being used in work platform service or each time the crane is converted from material lifting to personnel handling operation. In the event the operator is replaced, a new inspection is required. Written documentation of all inspections must be kept on the job site during personnel handling operations.
3. Inspect the crane and work platform for any loose, damaged, or missing components.
4. Any structural or functional defect which adversely affects the safe operation of the lift crane shall be corrected before any operation utilizing a work platform begins or continues.
5. The hoist drum shall have at least three full wraps of wire rope remaining on the drum at all times when using a work platform.
6. Minimum load hoist and boom hoist wire rope design factors for the combined weight of the lift attachments, work platform personnel, and tools shall be 10:1 for "Non-Rotating" and "Rotation Resistant" wire ropes. All other wire rope types require a 7:1 design factor. (Note: A.P.I. applications require 10:1 design factor for all wire rope construction.)

Operator's Manual

Telescopic Booms	Main Boom Head Sheaves	Auxiliary Head Sheaves	Fixed Fly Sheave	
	Allowed	Allowed	Allowed	
	Offset Fly Sheave	Offset Fly With Extension(s) Sheave	A-Frame Jib Sheave	
Conventional Lattice Tubular or Angle Booms	Main Boom Head Sheaves	Tip Extension Sheaves	Jib Head Sheave	
	Allowed	Allowed	Allowed	
Luffing Attachments	Luffing Boom Auxiliary Head Sheaves	Midfall Sheaves	Luffing Jib Head Sheaves	Fixed Jib Head Sheave
	Not Recommended	Allowed	Allowed	Not Recommended
Lifting Sheaves For Personnel Handling With Suspended Work Platforms				

7. The work platform shall be suspended from a wire rope that is reeved from an allowed lifting sheave. Refer to "Lifting Sheaves For Personnel Handling With Suspended Work Platforms" chart to determine the allowed sheave(s).
8. Inspect the wire ropes, sheaves, hoist drum brakes, and other mechanical and rigging equipment vital to the safe operation of the crane.
9. Ensure that all wire rope sockets and dead end lugs are properly installed and are in good working condition.
10. Ensure that all wire rope guards are in good working order and that they are properly installed and adjusted to prevent wire rope from jumping off sheaves.
11. Inspect all structural members of all boom sections, fly sections, luffing jib sections, and live mast, as equipped.
12. In addition to other regular inspections, visual inspection of the crane and work platform shall be conducted immediately after testing and prior to lifting personnel. The following inspections shall be conducted on extendable booms prior to lifting personnel:
 - a. Full power style booms:
 1. Inspection of all extension wire ropes at the access points in the boom where the end connections are visible – Refer to this Operator's Manual for inspection and adjustment procedures.
 - b. Pinning and latching style booms:
 1. Inspection of the latching mechanism, sensors, and hydraulic/electrical circuit at the access points.
 2. Inspection of all pins and pinning locations in the individual boom sections and at the fully retracted position.
 3. Verification of the accuracy of the boom length indicator. Refer to this Operator's Manual for the procedures.
13. The following inspections shall be conducted on fixed length style booms prior to lifting personnel:
 - a. Inspection of all pendants, pendant links, pendant spreader bars, links, etc.
 - b. Inspection of all mechanical linkages, shafts, drums, etc.
14. A written record of all the above inspections must be maintained on the job site.

Crane Test Procedures

The test procedures listed below shall be conducted at the following intervals:

- Daily,
- At each job site before hoisting employees,
- After any repairs or modifications to the equipment,
- When an operator is replaced, and
- When, in the judgement of responsible job site management, or controlling entity, there has been a significant change in the conditions of the personnel lifting operation.

Note: No personnel are allowed to ride the work platform during any of the tests recommended in this Section.

1. The work platform and rigging shall be proof tested to 125 percent of the work platform's rated capacity. (The proof test may be done concurrently with the trial lift by completing the following test procedures.) Do not exceed the rated lifting capacity of the applicable lift crane as listed on the crane capacity charts. (Refer to ANSI A10.28 for suspended work platform testing and inspection.)
 - a. This test load shall be tested for stability.
 - The operator and signal person shall conduct this test.
 - This test shall include movement of the work platform through its entire intended range of

Operator's Manual

- motion, simulating the specific operation to be undertaken.
- A successful stability test must not produce instability of the crane or cause permanent deformation of any component.
- b. This test load shall be raised and lowered at maximum power controlled line speed (NOT FREE-FALL). The acceleration must be smooth and the deceleration capability of the control/braking system shall be confirmed by bringing the work platform to a smooth stop. The work platform shall be held in a suspended position for a minimum of five minutes with the test load evenly distributed on the work platform. (This experience is intended to sharpen the skill of the operator in handling the work platform and to give the operator an opportunity to evaluate the crane's performance.) The work platform shall then be inspected for any evident sign of damage or defect.
 2. All limiting and warning devices shall be tested by activation of each appropriate control function.
 3. With pinning and latching style extendable booms, a visual inspection shall be conducted to verify that the boom extend pins are properly set in the extended boom sections.
 4. At the beginning of each lift, the work platform must be hoisted a few inches (*mm*) with the personnel and materials/tools on board and inspected by a competent person to ensure;
 - The work platform is secure and properly balanced,
 - All wire ropes are free of deficiencies such as kinking, crushing, corrosion, etc.,
 - Any multiple part lines are not twisted,
 - The primary attachment is centered over the work platform, and
 - If any load wire rope is slack, it must be inspected to ensure that all wire ropes are properly seated on the drum and in the sheaves.
 5. Any condition found during any of these tests/inspections that fails to meet requirements or may create a safety hazard, must be corrected before hoisting personnel.

Operation And Safety

1. This Crane Operator's Manual shall be read and fully understood by operating personnel. This Crane Operator's Manual shall be available to them at all times.
2. Safety when handling personnel remains the full responsibility of job site management and is dependent upon the responsible action of every person on the job involved in the related work.
3. Mobile lift cranes shall be erected to obtain maximum crane stability. The crane must be level and on firm ground. It is recommended that the outriggers be fully extended and the tires must be clear of the ground before beginning any operation.
4. The operator shall not leave the operator's station when the work platform is occupied. The operator shall remain alert in a position of readiness at the work station with the engine running and the master clutch engaged, if crane is so equipped.
5. Unauthorized personnel shall not be in the operator's cab on the lift crane, or near the lift crane while a work platform is suspended from the load line.
6. Any operation in which a work platform is to be suspended from the load line shall be carefully planned by the operator, supervisory personnel, designated signal person, and personnel to be lifted prior to commencement of such operation. They are to be advised:
 - a. That the crane does not have safety devices normally used on personnel handling equipment.
 - b. That the safety of the operation depends on the skill and judgment of the crane operator and others present.
 - c. Of procedures to enter and leave the work platform and other safety procedures.
7. After positioning of the work platform:
 - a. All brakes and locks on the lift crane shall be set before personnel perform any work.
 - b. With pinning and latching style extendable booms, a visual inspection shall be conducted to verify that the boom extend pins are properly set in the extended boom sections.
8. Telescope operation is not recommended with any extendable boom with personnel in a suspended work platform.
9. A work platform attached to load line of lift cranes shall not be used for working on any energized electric power line, or any energized device or facility used for electric power generation or transmission. Minimum working clearance shall be at least twice that recommended for material handling operations in ANSI B30.5b section 503.4.5 and ANSI B30.23.
10. The combined weight of the work platform, any attachment device, personnel, tools, and other equipment shall not exceed 50% of the lifting capacity of the applicable lift crane as listed on the crane capacity chart. (Note: A.P.I. applications require 25% of lifting capacity as the limit.)
11. Use caution when utilizing pendant supported lattice jibs on tubular or angle booms as the jib can drift backwards into the jib backstops under certain conditions. This is most likely with short jib lengths with minimum jib offset and maximum boom angle. Pay special attention to detect the possibility of jib drift during the work platform test lift. An additional test lift is recommended with an empty work platform when operation at or near these conditions.
12. The following actions and operations are strictly prohibited when working with personnel suspended in a work platform:

Operator's Manual

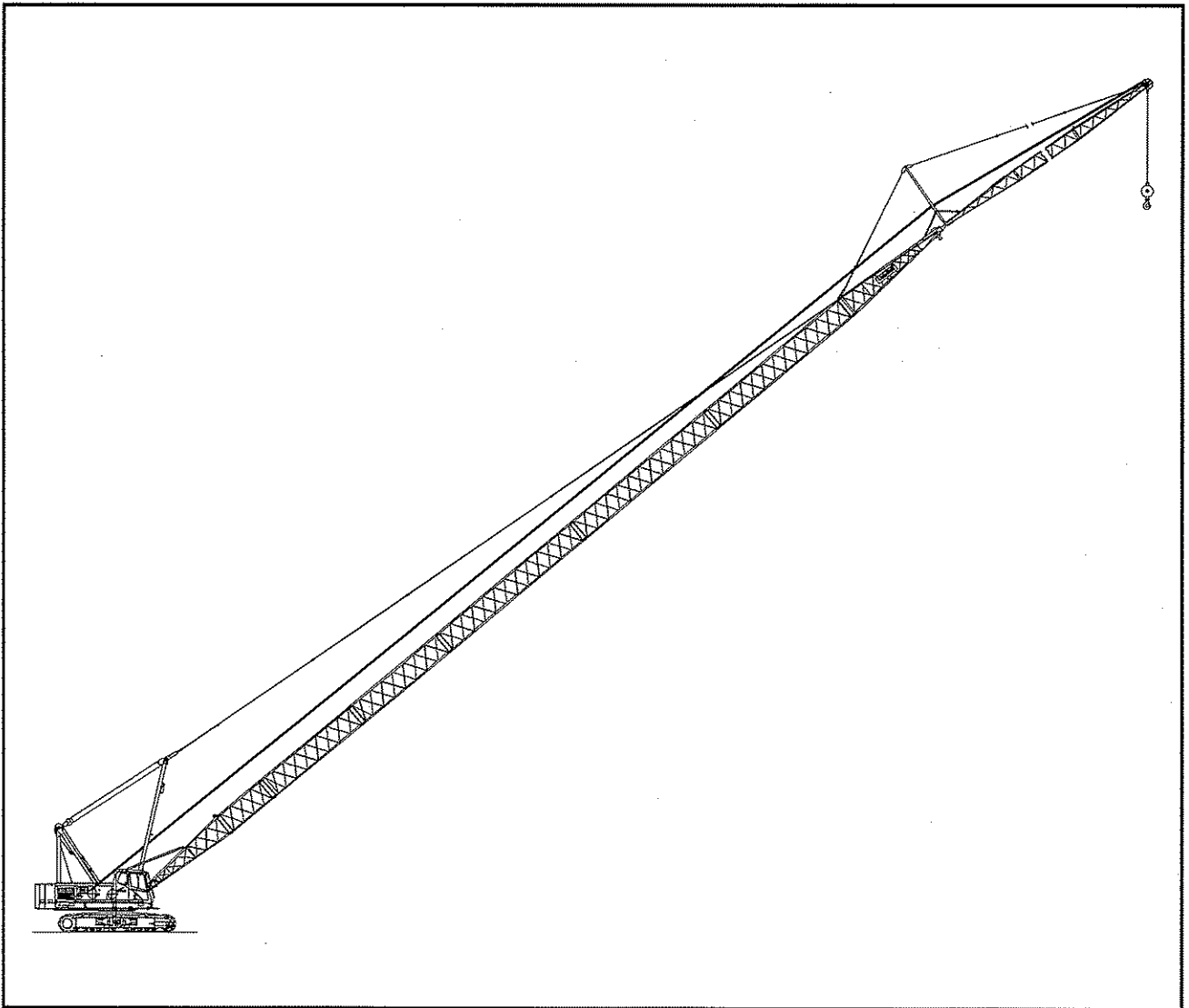

Crane Serial Number

The crane serial number is on the Crane Rating Manual in the operator's cab. The crane serial number should always be furnished when ordering parts for the crane, or when corresponding with the Link-Belt Distributor or factory regarding the crane. The serial number is the only method the Link-Belt Distributor or factory has of ensuring that the correct parts will be furnished.

In the event the serial number cannot be found on the Crane Rating Manual, a number is stamped on the front face of the upper frame, between the boom foot mounting lugs. This number can then be used to help to identify the crane.

Operator's Manual

- a. Cranes shall not travel while personnel are in the work platform.
 - b. No lifts shall be made on another of the crane's load lines with personnel suspended in a work platform.
 - c. No external load is allowed to be lifted by attaching it to the work platform.
 - d. Work platform lifts shall be a single crane operation. A work platform shall not be lifted using two cranes.
 - e. Hoisting of personnel shall be discontinued upon indication of any dangerous weather conditions, wind, or other impending danger.
 - f. The emergency manual mode operation of pinning and latching style extendable booms shall not be utilized.
 - g. Free-fall (if equipped) shall not be used.
13. Movement of the work platform with personnel shall be done in a slow, controlled, cautious manner with no sudden movements of the crane or work platform. Do not use high speed functions, if equipped.
 14. Do not use multi-function crane operation. If load hoist, boom hoist, and swing functions must be used to position the work platform, perform each function individually.
 15. Clear, unobstructed visibility between personnel on the work platform and the crane operator shall be maintained at all times except where a designated signal person has been assigned and positioned such that he is visible to both. Such designated signal person shall have no other duties to perform when personnel are in the work platform.
 16. Voice communication between work platform personnel, the crane operator, and designated signal person, if assigned, shall be maintained.
 17. If other cranes or equipment may interfere with the lifting of personnel, signals or other means of communication between all crane or equipment operators shall be maintained to avoid interference with individual operations.
 18. If the work platform is not landed, it shall be tied to a structure before personnel mount or dismount the work platform.
 19. Personnel in the work platform shall wear personal fall arrest systems. Anchors used for attachment of personal fall arrest equipment shall be independent of any anchors being used to support or suspend work platforms. Personnel shall keep all parts of body, tools, and equipment inside work platform during raising, lowering, and positioning.
 20. Personnel shall always stand firmly on the floor of the work platform and shall not sit or climb on the edge of the work platform or use planks, ladders,

or other devices for attaining a work position. (This does not apply to offshore personnel transfer baskets. Personnel must ride on the exterior of this type of personnel handling device to assure greater safety of the operation.)

21. When welding is done by personnel in the work platform, the electrode holders shall be protected from contact with metal components of the work platform. If electrically connected electrode holders contact work platform, work platform could be dropped due to burning/melting of wire ropes suspending the work platform.
22. A pre-lift meeting must be conducted with the crane operator, signal person, employee(s) to be hoisted, person responsible for the task to be performed, and anyone else that is directly involved with the lift (as applicable) to review all the requirements and procedures that must be followed to complete the lift.
23. Follow all procedures for determining the rated capacity and perform all testing as outlined in this Crane Operator's Manual and the Crane Rating Manual.

Additional Requirements For Offshore Cranes

1. Link-Belt offshore cranes are designed to handle materials. However, due to the special conditions commonly existing offshore, the use of cranes to transfer personnel between vessels or from a vessel to a work platform is an established practice. The safety of the personnel, if a materials handling crane is used in transferring personnel, depends upon the skill and judgment of the crane operator and alertness of the personnel being transferred. Sea and weather conditions may create additional hazards beyond the skill of persons involved.

This operation is approved by the American Petroleum Institute (A.P.I.). By adopting procedures for this operation, the institute has determined that the transfer of personnel may be performed safely under certain offshore conditions. Therefore, whenever an offshore crane is used to transfer personnel, all persons involved in the operation must know and implement the A.P.I. procedures and verify that sea and weather conditions are within safe limits for the transfer.

In addition to all previous requirements in these Instructions, A.P.I. 2C requires the following:

- Boom and load hoists used shall be approved by the hoist manufacturer for personnel handling and shall be so indicated on their name plate.
- Refer to A.P.I. 2C Section 6 for further details and procedures.

Operator's Manual

Personnel Handling Pre-Lift Check List for Link-Belt Cranes



1	<p>I am the designated person responsible for verifying that all safety requirements are met for this personnel handling operation;</p> <p>Name: _____ Title: _____</p> <p>Signature: _____ Date: ____/____/____ Initials</p>
2	I have verified that there are no conventional means to handle personnel for this operation.
3	I have a written statement authorizing personnel handling from a competent person on the job who accepts full responsibility, or I accept full responsibility for the operation.
4	The Crane Operator acknowledges that he has read and fully understands the Crane Operator's Manual and Crane Rating Manual. All personnel involved have been informed and understand the tasks required to complete the personnel lifting operation.
5	The crane has been maintained, lubricated, and adjusted by a designated person, as specified in the Crane Operator's Manual.
6	<p>The lift crane is equipped, and all devices operate properly as follows:</p> <ul style="list-style-type: none"> • Anti-two block device with hydraulic cutouts • Power load raising and lowering with automatic brakes and function cutouts – Free-Fall (if equipped) shall not be used • Boom angle indicator with high and low set points and function cutouts • Boom length indicator (telescopic booms only) and function cutouts • Load Indicating System or Rated Capacity Limiter System • A variable swing brake or swing controls capable of stopping upper swing motion smoothly • A mechanical swing park brake or swing lock to hold the upper in position while personnel are working from the work platform • Hook block or hook ball being used can be closed and locked with a safety latch
7	A working audible and visual alert system is provided to the personnel in the work platform.
8	A mechanical and structural crane inspection has been completed by a designated person.
9	The wire rope used to lift the work platform is reeved from an allowed lifting sheave
10	Crane travel is not allowed with personnel in the work platform.
11	Telescoping the boom is not recommended with personnel in the work platform.
12	When handling personnel with pinning and latching style booms, it is recommended boom be kept in a pinned position. Inspections must be made to ensure boom extend pins are set.
13	All wire rope sockets and dead end lugs are properly installed and are in good working condition. All wire rope guards are properly installed and adjusted to hold all wire ropes on the appropriate sheaves.
14	Voice communications between the Crane Operator and the personnel in the work platform are present and operational.
15	Fall arrest systems are present and in use by personnel in the work platform.
16	Weather and wind conditions are acceptable to safely perform the lift.
17	A Proof-Test/Trial Lift was completed with 125% of the work platform's rated capacity.
18	The total load being lifted will not exceed 50% of the standard lift crane capacity charts.
19	Cranes with outriggers have them equally extended with tires clear of the ground.
20	A Pre-Lift meeting was held with all appropriate personnel to review all aspects of the lift.

Note: This checklist is to be used as a supplement to (not a substitute for) the information and procedures supplied for personnel handling operations.

Operator's Manual

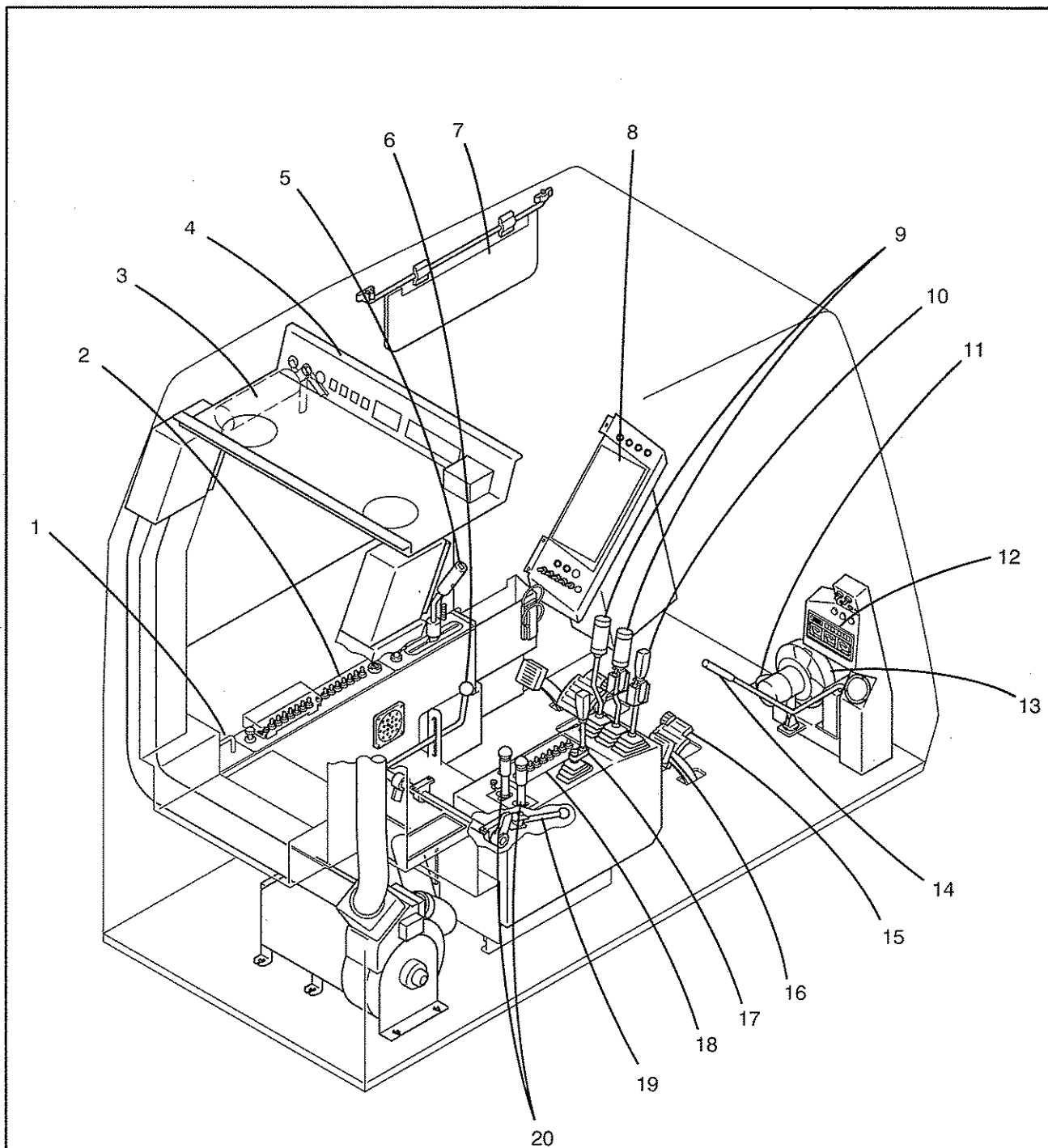

- 1. Electrical Control Unit
- 2. Left Control Console
- 3. Fire Extinguisher
- 4. Overhead Control Panel
- 5. Swing Control Lever
- 6. Side Frame Extend/Retract Control Lever

- 7. Sun Visor
- 8. Load Moment Indicator Panel
- 9. Winch Drum Control Levers
- 10. Boom Hoist Control Lever
- 11. Bubble Level
- 12. Front Control Console
- 13. Operator's Cab Fan

- 14. Gate Lock Lever
- 15. Winch Drum Brake Pedals
- 16. Throttle Pedal
- 17. Third/Fourth Drum Control Lever
- 18. Right Control Console
- 19. Swing Lock Control Lever
- 20. Travel Control Levers

Figure 1-41
Operator's Cab Controls

Operator's Manual

Fire Extinguisher

A fire extinguisher is mounted in the upper rear of the operator's cab. Refer to Figure 1-41. It is an A B C type fire extinguisher, meaning it is capable of extinguishing most types of fires. The operator should be familiar with its location, the clamp mechanism used to secure it in place, and the operation of the device. Specific instructions, regarding operation, are given on the label attached on the fire extinguisher. A charge indicator on the fire extinguisher monitors the pressure within the tank. Check the indicator daily to ensure the fire extinguisher is adequately charged and ready for use.

Operator's Cab

Several consoles and panels which contain the controls, switches, and gauges to operate and monitor crane operations, are mounted throughout the operator's cab. Refer to Figure 1-41. The following is a description of each gauge, switch, or control in each panel, along with an explanation of their function and/or operation.



WARNING

Read and understand all "Operating Safety" instructions in this Operator's Manual before attempting to operate the crane. This crane should only be operated by a qualified operator who has read and understood this entire Operator's Manual.

Overhead Control Panel

The overhead control panel is mounted above the operator's seat in the rear of the operator's cab. Refer to Figure 1-42.

1. Operator's Cab Interior Light

Use switch below the light to turn the light on or off.

2. Operator's Cab Fan Switch

This switch controls the operator's cab fan on the floor in front of the operator. Push the switch with "-" mark to operate the fan; push the switch with "o" mark to turn the fan off.

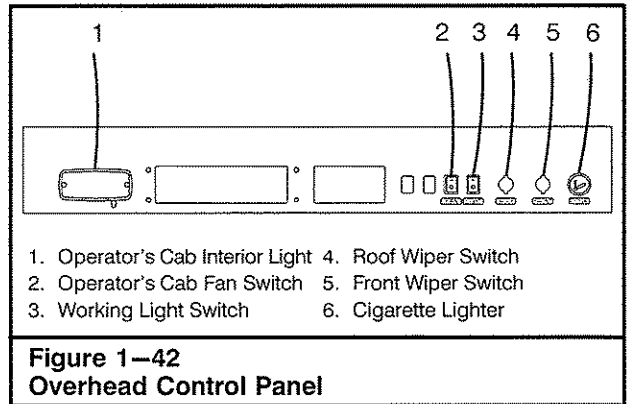

- | | |
|----------------------------------|-----------------------|
| 1. Operator's Cab Interior Light | 4. Roof Wiper Switch |
| 2. Operator's Cab Fan Switch | 5. Front Wiper Switch |
| 3. Working Light Switch | 6. Cigarette Lighter |

Figure 1-42
Overhead Control Panel

3. Working Light Switch

This switch controls the working lights on the upper. Push the switch with "-" mark to turn the lights on; push the switch with "o" mark to turn the lights off.

4. Roof Wiper Switch

This switch controls the roof wiper. Turn the switch clockwise to operate the roof wiper; turn it counterclockwise to turn it off. Push the switch to spray washer liquid on the roof window.

5. Front Wiper Switch

This switch controls the front windshield wiper. Turn the switch clockwise to operate the windshield wiper; turn it counterclockwise to turn it off. Push the switch to spray washer liquid on the windshield.

6. Cigarette Lighter

Push knob in to heat element. The knob will pop up when the element is hot.

CAUTION

Do not connect an accessory to any part of the crane other than the accessory outlet or cigarette lighter. Damage to the crane's electrical system may result. If it is necessary to do so, contact your Link-Belt Distributor.

Operator's Manual

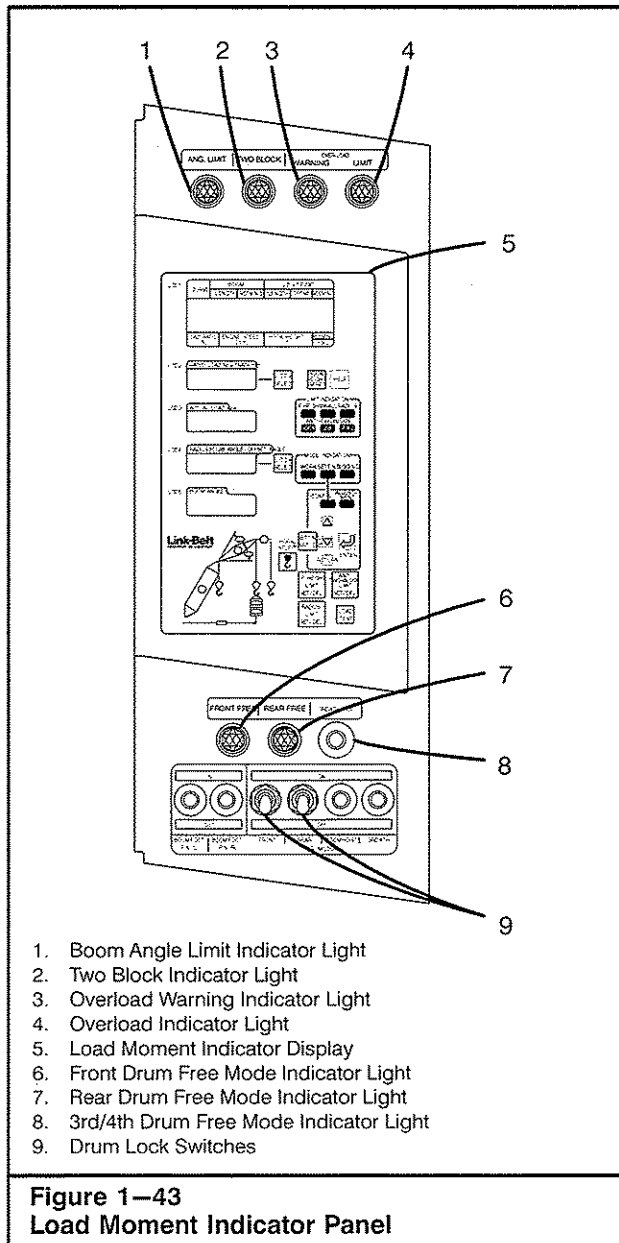

Load Moment Indicator Panel

The Load Moment Indicator panel is mounted to the left front of the operator. It contains the following and is shown in Figure 1—43.

1. Boom Angle Limit Indicator Light

This light will illuminate to alert the operator when the boom has reached its lowering or hoisting limit. The voice alarm “Boom Hoist Limit” or “Boom Lower Limit” will sound simultaneously and the boom hoist or lower function will become disabled. The boom hoist drum control lever will now operate only in one position unless the appropriate override switch is employed. Position the boom, as required, to turn the light off and silence the voice alarm. For further information, also see “Master Control Override Switch” and “Boom Hoist Limit Override Switch” or “Boom Lowering Limit Override Switch”.

2. Two Block Indicator Light

This light will illuminate any time a two block situation is imminent. The voice alarm “Two Block Limit” will also sound. Use the Anti-Two Block Override switch to correct the two block situation and return to normal working mode.

3. Overload Warning Indicator Light

The Overload Warning Indicator (amber) illuminates at a pre-set value of 90 % of Maximum Rated Capacity and provides a visual indication of an approach to an overload.

4. Overload Indicator Light

The Overload Indicator (red) illuminates at a pre-set value of 100 % of Maximum Rated Capacity. It will also illuminate whenever a wire rope limit is exceeded or an operator settable alarm has been reached or exceeded. Function limiters will occur simultaneously for an Overload, Wire Rope Limit, or a Two Block condition. The voice alarm “Overload Limit” will sound for all 3 conditions.

Operator's Manual

5. Load Moment Indicator Display

This system has function limiter (cutout) ability intended to aid the operator in the efficient operation of the crane by continually monitoring the load and warns of an approach to an overload condition. See "Crane Monitoring System" in this Section of this Operator's Manual.

6. Front Drum Free Mode Indicator Light

This light will illuminate to alert the operator that the Front Drum Brake Mode/Drum Control Lock switch on the right control console is in the "FREE" position. The automatic brake for the front drum is inactive and the front drum brake pedal must be used to control the load.

7. Rear Drum Free Mode Indicator Light

This light will illuminate to alert the operator that the Rear Drum Brake Mode/Drum Control Lock switch on the right control console is in the "FREE" posi-

tion. The automatic brake for the rear drum is inactive and the rear drum brake pedal must be used to control the load.

8. 3rd/4th Drum Free Mode Indicator Light

This light will illuminate to alert the operator that the 3rd/4th Drum Brake Mode/Drum Control Lock switch on the right control console is in the "FREE" position. The automatic brake for the 3rd/4th drum is inactive and the 4th drum brake pedal must be used to control the load.

9. Drum Lock Switches

These switches control the pawls on the front or rear drums. When engaged, the pawls will not allow the winch drum to rotate in a lowering direction, however, the drum pawls will ratchet, allowing the drums to rotate when raising a load. Move the switch up to the "ON" position to engage the pawl or down to the "OFF" position to release it.

Operator's Manual

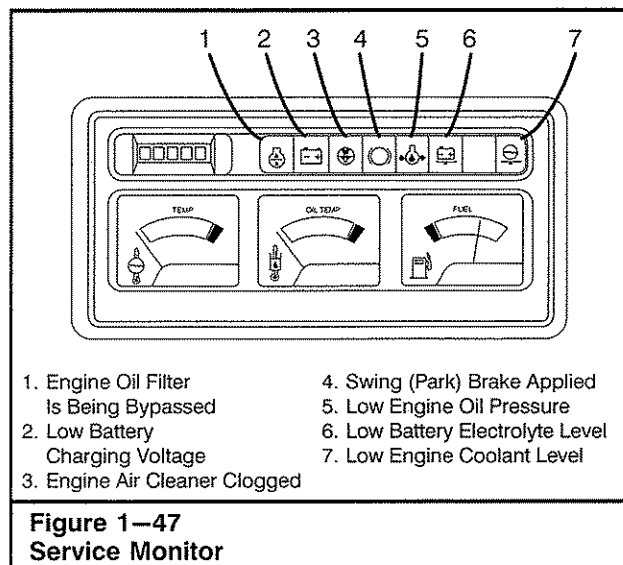

5. Service Monitor

Individual indicator lights are contained in this gauge. Refer to Figure 1—47. The appropriate indicator light will illuminate for any of the following conditions:

- Engine oil filter is being bypassed
- Low battery charging voltage
- Engine air cleaner clogged
- Swing (Park) brake applied
- Low engine oil pressure
- Low battery electrolyte level
- Low engine coolant level

Note: All of the indicator lights are tested when the Engine Starter Key Switch is moved from the "OFF" position clockwise to the first position. If these lights do not illuminate when tested, locate and repair the problem before continuing operations.

6. Engine Fuel Level Gauge

This gauge registers the fuel level in the tank. A sight gauge is also on the side of the fuel tank. The fuel tank capacity is 76 gal (288L). Refer to the engine manufacturer's manual for correct grade of diesel fuel.

7. Hydraulic Oil Pressure Gauge

This gauge registers the hydraulic oil pressure of the crane control system. Normal operating pressure is 1,140 psi (80kg/cm²). If the hydraulic oil pressure varies more than ±50 psi (±3.5kg/cm²) shutdown the crane immediately and correct the problem. The indicator will gradually return to zero when the engine is shutdown.

8. Tachometer

The tachometer registers engine speed in revolutions per minute (rpm). Refer to the engine manufacturer's manual for suggested operating speeds. The engine speed is not displayed on the LMI Display.

9. Hydraulic Oil Temperature Gauge

This gauge registers the hydraulic oil temperature in the reservoir. Normal operating range will register in the green area of the gauge, provided the proper viscosity of oil is used. (Operating ranges vary with the oils used in different climates. Refer to Section 2 of this Operator's Manual for proper oil viscosities for operating in different temperature ranges.) If the hydraulic oil exceeds the maximum operating temperature and the indicator moves to the red area of the gauge, shutdown the crane immediately and correct the problem.

10. Engine Water Temperature Gauge

This gauge registers the engine cooling system temperature. For proper cooling system operating temperature range, refer to the engine manufacturer's manual. If the cooling system overheats, shutdown the engine immediately and repair the problem to avoid engine damage.

11. Hour Meter

The hour meter registers engine operating time in hours, up to five digits. The far right representing 1/10 of an hour. The hour meter is useful in determining lubrication and maintenance schedules. This meter will register only when the engine is running.

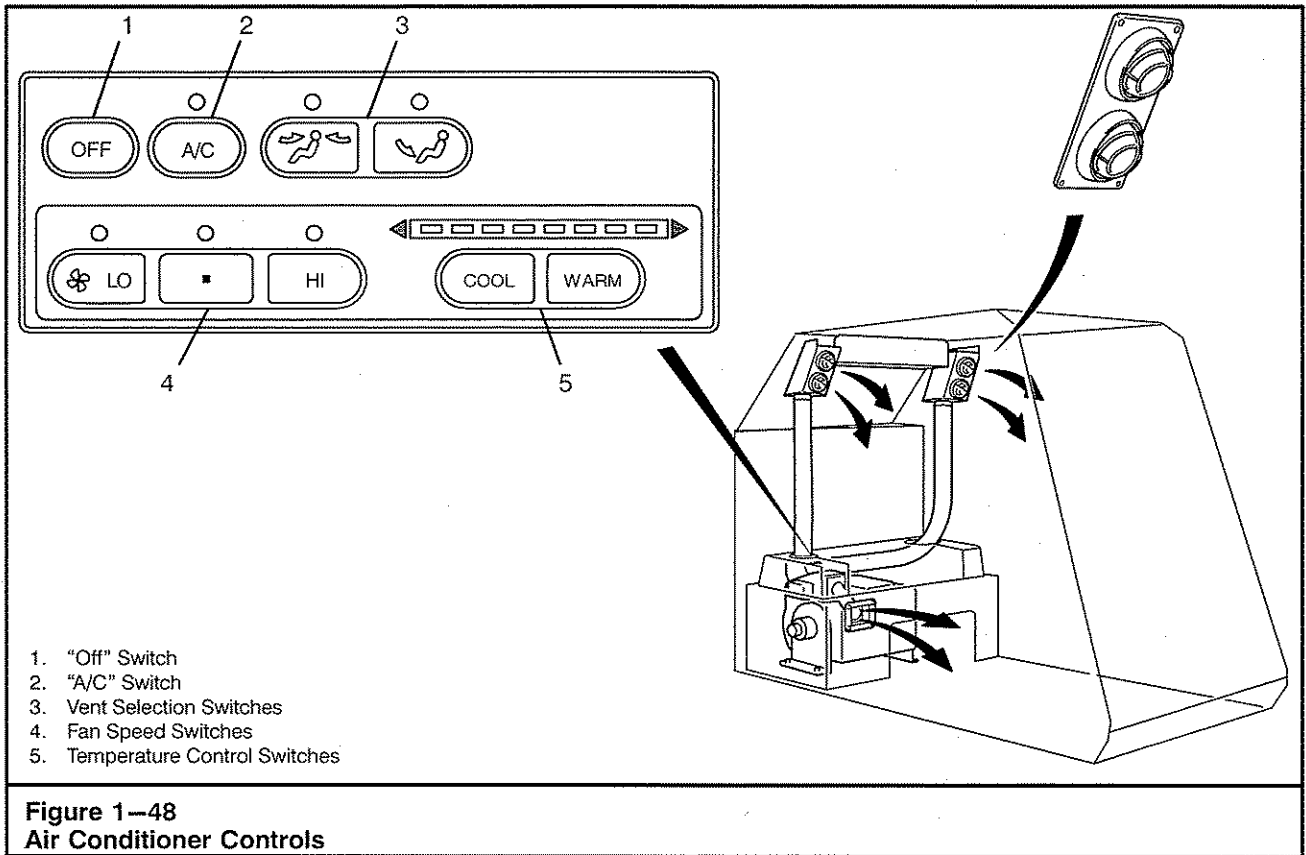

Air Conditioner Controls

The air conditioner control panel is to the right of the operator's seat. Refer to Figure 1—48. Use the following control descriptions to adjust the temperature inside the operator's cab.

1. "Off" Switch

Pushing this switch will stop the air flow from the vents.

2. "A/C" Switch

Push this switch to turn the air conditioner "ON" or "OFF". The indicator light above the switch will illuminate to indicate that the air conditioner is "ON".

Note: If the outside temperature reaches zero, the compressor cannot be started even if the "A/C" switch is pressed "ON".

3. Vent Selection Switches

Use these switches to select the required operator's cab ventilation. Select one switch to allow air flow from the upper vent and one for the lower vent. Press both switches to provide air flow from both vents for maximum operator's cab ventilation. The indicator light above the switch will illuminate to indicate which vent(s) is selected.

4. Fan Speed Switches

Use these switches to control the amount of air flowing from the vents: Low, Medium, or High.

5. Temperature Control Switches

Use these switches to adjust the temperature in the operator's cab. Press the "COOL" switch to lower air temperature and the "WARM" switch to raise air temperature.

Operator's Manual

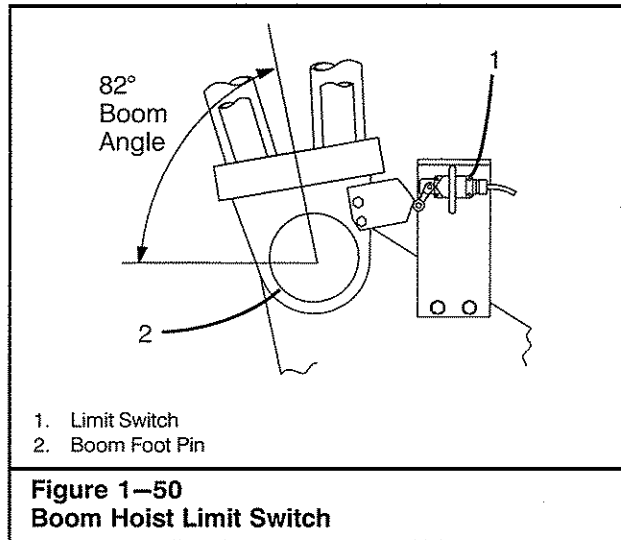

Boom Hoist Limit System

The crane is equipped with a boom hoist limit system that is used to prevent over hoisting the boom. When the boom reaches the maximum angle, a limit switch at the base end of the boom is tripped which disables the boom hoist function and prevents the boom from being raised any further. A voice alarm "Boom Hoist Limit" sounds and an indicator light will activate simultaneously signaling the operator that maximum boom angle has been reached, approximately 82°. Refer to Figure 1-50.

The boom must be lowered in order to silence the alarm. However, to release the boom hoist drum lock and lower the boom, it may be necessary to raise the boom slightly to disengage the boom hoist drum pawl. The boom hoist override switch is then used to reactivate the boom hoist function to raise the boom enough to release the drum lock and lower the boom. The indicator light will continue to flash and the voice alarm to sound even after this switch is pushed. To reset the boom hoist limit system, lower the boom until the boom hoist limit indicator light goes off and the audible alarm is silenced. Refer to Figure 1-49.

Boom Hoist Override Switch Operation

1. With the engine at idle, move the pump control switch to the "ON" position.
2. Turn the Master Control Override Switch to the "ENABLE" position.
3. Hold the Boom Hoist Limit Override Switch in the "OVERRIDE" position.
4. Slightly raise the boom, then slowly lower the boom until the boom angle is less than 80°.
5. Release the Boom Hoist Limit Override Switch to the "NORMAL" position.
6. Turn the Master Control Override Switch to the "DISABLE" position.

Boom Backstop Limit

The boom backstop limit system is designed to prevent the boom from over hauling and damaging the backstops. When boom angle reaches approximately 82°, the backstop limit switch, mounted on the backstops, is tripped which disables the boom hoist and lowering functions. To restore boom hoist and lowering functions, the Backstop Limit Override Switch must be used. Refer to Figure 1-49. Use the following procedure when using the override switch:

1. With the engine at idle, move the pump control switch to the "ON" position.
2. Turn the Master Control Override Switch to the "ENABLE" position.

Note: The Master Control Override Switch may have already been moved to the "ENABLE" position when the boom hoist limit switch was tripped.

3. Hold the Backstop Limit Override Switch in the "OVERRIDE" position.
4. Slowly lower the boom until the boom angle is less than 82°.
5. Return boom hoist lever to neutral and release the Backstop Limit Override Switch to the "NORMAL" position.
6. Turn the Master Control Override Switch to the "DISABLE" position.

Boom Lower Limit

When lowering the boom below the working radius listed in the Crane Rating Manual, the boom lower limit is activated disabling the boom lowering and winch hoist functions. A voice alarm "Boom Lower Limit" and "Overload Limit" sounds and an indicator light will activate simultaneously. In emergency situations, it may be necessary to lower the boom further. In this case, the Boom Lower Limit Override Switch is used. Refer to Figure 1-49. Use the following procedure when using the override switch:

1. With the engine at idle, move the pump control switch to the "ON" position.
2. Lower the hook block and/or hook ball to the ground.
3. Turn the Master Control Override Switch to the "ENABLE" position.
4. Hold the Boom Lower Limit Override switch in the "OVERRIDE" position.
5. Slowly lower the boom until the boom angle is less than 82°.
6. Release the Boom Lower Limit Override switch to the "NORMAL" position.
7. Turn the Master Control Override Switch to the "DISABLE" position.

Operator's Manual

Boom Angle Indicator

A mechanical type boom angle indicator is mounted to the left of the operator's cab on the base section of the boom. Refer to Figure 1-51. It must be adjusted properly, free from binding, and the crane must be level for the unit to accurately indicate boom angles. Even under these conditions its readings are only approximate. When making near capacity lifts, measure the load radius to determine crane capacity. Check the adjustment of the boom angle indicator daily to ensure its accuracy.

Front And Rear Drum Operation

Raising and lowering a load is controlled by the front and rear drum control levers, drum lock switches, pump control switch, and drum brake mode/drum control lock switch. Front and rear drum brake pedals are also used to control the load and operate either manually or automatically. Refer to Figure 1-49.



WARNING

The weight of the load must be known before making a lift. Compare the load weight to the appropriate capacity chart in the Crane Rating Manual to ensure compliance with capacity ratings. Compare the load weight to the Wire Rope Capacity Chart in the Crane Rating Manual to determine the number of parts of line required to lift the load. Rig and set up the crane to ensure compliance with Wire Rope Capacity Chart and the Crane Rating Manual.

The front and rear drum control levers have two speeds of operation in both raising and lowering mode. Moving the control lever forward or backward engages the 1st speed of operation. As the control lever is moved further, a 2nd and faster speed is obtained. This design, when combined with the pump control feature, provides the operator with four speeds of operation in both the raising and lowering mode. The engine throttle setting will also effect the speed of operation. Refer to Figure 1-49.

The brake system for the front and rear drums has two modes of operation. Drum brakes can be selected to operate in an automatic or manual mode. When the drum brake mode/drum control lock switch on the right control panel (Figure 1-45) is in the "AUTO BRAKE" position, the drum brake applies automatically any time the control lever is in the neutral position. When it is in the "FREE" position, the drum brake must be manually applied using the brake pedal(s) on the operator's cab floor.

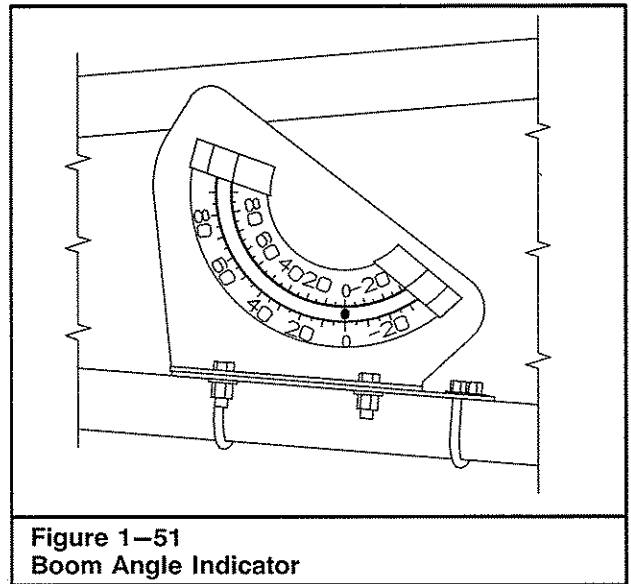

**Figure 1-51
Boom Angle Indicator**

The following procedures give instructions for raising and lowering the load based on the the type of brake system used. However, variations in load and job site conditions may require adaptations to these general procedures. Crane operations are to be performed only by a qualified operator who has read and fully understands the entire content of this Operator's Manual.

Operating In "AUTO BRAKE" Mode

1. Refer to the Crane Rating Manual for proper crane set up based on load radius, working area, etc.
2. Position the head machinery directly above the load. Connect the hook block or hook ball to the load.
3. With the engine at idle, move the pump control switch on the control lever to the desired position ("ON" for low speed or "OFF" for high speed).
4. Check that the drum lock switch is in the "ON" position. (The drum pawl will ratchet allowing the load to be lifted.)
5. Fully apply and latch the drum brake foot pedal on the operator's cab floor.
6. Move the Drum Brake Mode/Drum Control Lock switch on the right control console to the "AUTO BRAKE" position. Check that the free mode indicator light on the LMI panel is off.
7. Unlatch and release the drum brake pedal.

Operator's Manual



WARNING

CONSTRUCTION EQUIPMENT CAN BE DANGEROUS IF IMPROPERLY OPERATED OR MAINTAINED. THIS MACHINE SHOULD BE OPERATED AND MAINTAINED ONLY BY TRAINED AND EXPERIENCED PEOPLE WHO HAVE READ, UNDERSTOOD, AND COMPLY WITH THIS OPERATOR'S MANUAL.

The productive life of construction equipment depends largely on the care and consideration given to it. This especially holds true for crawler cranes. This Operator's & Maintenance Manual was compiled to explain the procedures and adjustments necessary for proper operation of this crane.

A study of this Operator's Manual will acquaint the operator and service personnel with the construction of this crane. It will enable them to identify and remedy most problems that may occur. Any questions pertaining to the care and upkeep of this crane which are not covered in this Operator's Manual should be directed to your Link-Belt Distributor.

The Operator's Manual is stored in a pocket or box near or behind the operator's seat. The Operator's Manual should remain in the cab and accessible at all times. **If the Operator's Manual becomes lost, damaged, or unreadable, it must be replaced before operating the crane.**

In addition to this Operator's & Maintenance Manual, a Parts Manual, Crane Rating Manual, and Safety Manual are supplied with the crane. Read and understand all safety guidelines before operating the crane. Additional copies of all manuals are available through your Link-Belt Distributor.

Operator's Manual



WARNING

Do not lift a load to the point where the hook block, hook ball, or load contacts the head machinery. "Two blocking" could damage the hook block, hook ball, and/or the head machinery, allowing the load to fall. Always keep the hook block, hook ball, and load a safe distance from the boom.

8. **To Raise The Load:** Slowly pull back on the drum control lever. If desired, increase the engine throttle to speed up the winch once the load begins to move. After the load reaches the desired height, slowly move the drum control lever to the neutral position to stop the load.

CAUTION

Do not use the drum brake foot pedals when in the "AUTO BRAKE" mode, except to hold the load for an extended period of time. Hoist levers must be in neutral.

To Hold The Load: With the drum control lever in the neutral position, fully apply and latch the drum brake foot pedal. Check that the drum lock switch is in the "ON" position.

To Lower The Load: Unlatch and fully release the drum brake foot pedal. Move the drum lock switch to the "OFF" position and slowly move the drum control lever forward. If desired, increase the engine throttle to speed up the winch once the load begins to move. After the load reaches the desired height, throttle down and slowly move the drum control lever to the neutral position to stop the load. If the drum lock switch is placed in the "ON" position, the front and rear drum winch will not function even if the front or rear drum control levers are placed in the "Lowering" position.

Note: It may be necessary to raise the load slightly to allow the drum pawl to release when lowering the load.

Operating In "FREE" Mode

1. Refer to the Crane Rating Manual for proper crane set up based on load radius, working area, etc.
2. Position the head machinery directly above the load. Connect the hook block or hook ball to the load.
3. With the engine at idle, move the pump control switch on the control lever to the desired position ("ON" for low speed or "OFF" for high speed).

4. Check that the drum lock switch is in the "ON" position. (The drum pawl will ratchet allowing the load to be lifted.)
5. Fully apply and latch the drum brake foot pedal on the operator's cab floor.
6. Move the Drum Brake Mode/Drum Control Lock switch on the right control console to the "FREE" position. The voice alarm sounds "Free Mode Activated." Check that the free mode indicator light on the LMI panel is illuminated.
7. Fully apply the brake pedal of the drum that "Free" is selected. The pedal gets heavy. Check to see that the free mode indicator light is illuminated.



WARNING

Do not lift a load to the point where the hook block, hook ball, or load contacts the head machinery. "Two blocking" could damage the hook block, hook ball, and/or the head machinery, allowing the load to fall. Always keep the hook block, hook ball, and load a safe distance from the boom.

8. **To Raise The Load:** Pull back on the drum control lever while slowly releasing the drum brake foot pedal. If desired, increase the engine throttle to speed up the winch once the load begins to move. After the load reaches the desired height, throttle down and slowly apply the drum brake pedal while moving the drum control lever to the neutral position.

To Hold The Load: With the drum control lever in the neutral position, fully apply and latch the drum brake foot pedal. Check that the drum lock switch is in the "ON" position.

CAUTION

Do not lower the load when the drum pawl is applied as damage to the drum may result.

To Lower The Load: Move the drum lock switch to the "OFF" position. With the drum control lever in neutral, slowly release the drum brake foot pedal and allow the load to lower slowly. The speed at which the load falls is regulated by the pressure applied to the drum brake pedal. After the load reaches the desired height, slowly apply the drum brake pedal and bring the load to a complete stop. Engage the drum pawl by moving the drum lock switch to the "ON" position.

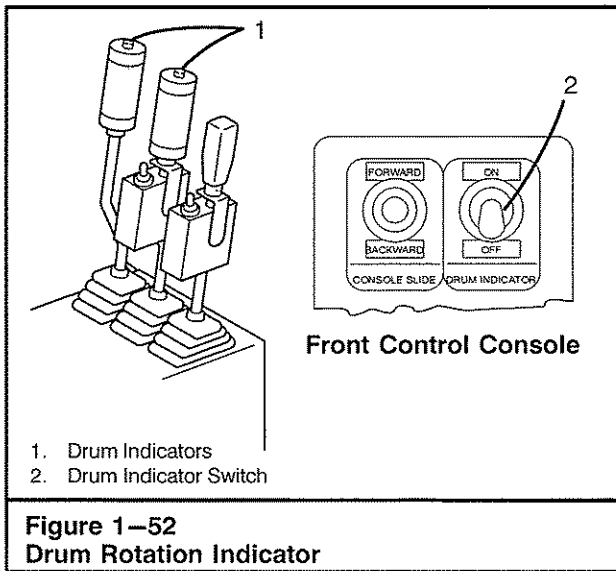

Third/Fourth Drum Control

The crane may be equipped with a third/fourth drum control lever. This lever is used for the third drum mounted in the boom foot area or rear mounted fourth drum. Refer to Figure 1-49. Refer to "Third Drum Winch" or "Fourth Drum Winch" in this Section of this Operator's Manual for more information.

Drum Rotation Indicator

This system is used to monitor winch drum speeds through the use of a vibration signaling device mounted on the winch control lever. Refer to Figure 1-52. As the winch drum rotates, a vibrating signal relative to the speed of the winch drum is felt in the drum indicator on the winch drum control lever. The faster the rotation of the winch drum, the faster the vibrating signal. Move the Drum Indicator switch to the "ON" position to activate the lever indicators.

Upper Horn

The upper horn switch is on the swing control lever. Refer to Figure 1-53. To sound the horn, press the switch.

Swing Operation

Rotation of the upper over the lower is controlled by the swing control lever, swing (park) brake switch, and swing lock control lever. The system also incorporates a swing alarm which sounds any time the swing control lever is moved out of the neutral position. Refer to Figure 1-53.

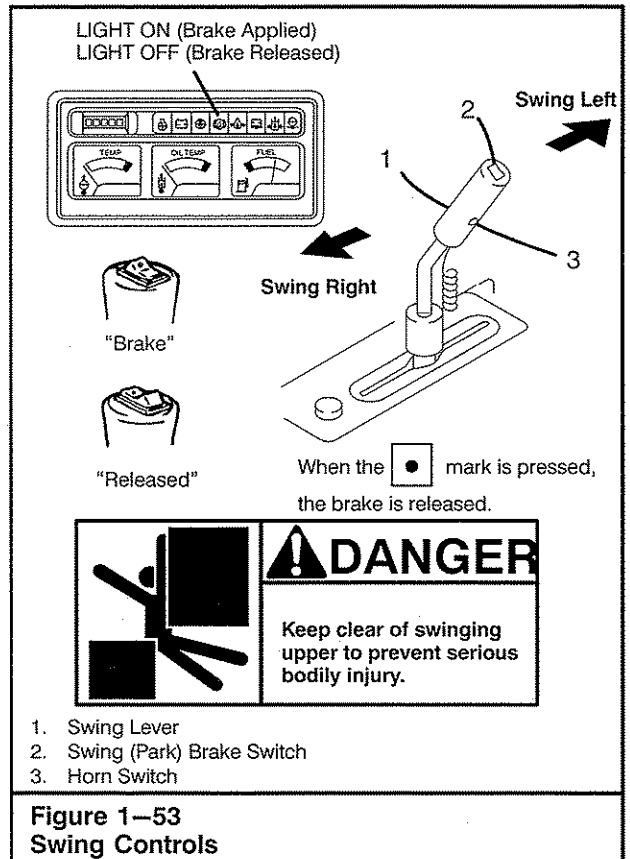

The swing control lever, to the left of the operator on the control console, operates the swing function. Move the control lever forward to swing left; move it back to swing right. The swing (park) brake switch is also on the same control lever along with the upper horn switch.

Swing (Park) Brake

CAUTION

Do not apply the swing (park) brake with the upper in motion. This practice will result in damage to the swing mechanism. Stop the swinging upper by slowly engaging the swing control lever in the opposite direction to that which started the swing. Apply the swing (park) brake only after the upper comes to a complete stop.

Use the swing (park) brake for holding the upper in any position, over the lower during normal, stationary crane operations. The electrically activated swing (park) brake is applied using the swing (park) brake switch on the top of the swing control lever. Refer to Figure 1-53.

Operator's Manual

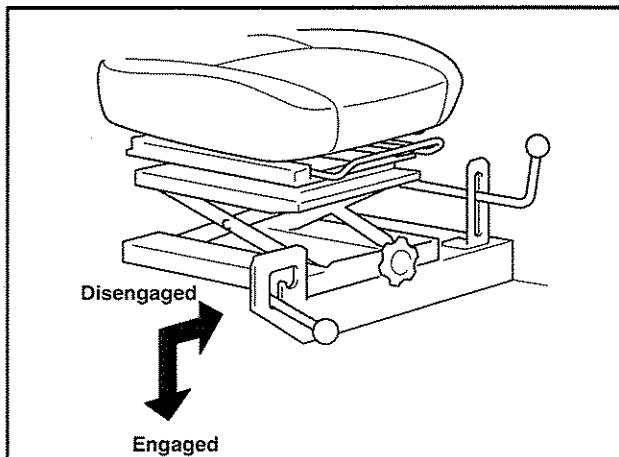

Figure 1-54
Travel Swing Lock Control Lever

Travel Swing Lock

The crane is equipped with a travel swing lock. The travel swing lock control lever is below and to the right of the operator's seat. Refer to Figure 1-54.

CAUTION

Do not engage the travel swing lock or swing (park) brake with the upper in motion. This practice will result in damage to the swing mechanism or other crane components. Stop the swinging upper by slowly engaging the swing control lever in the opposite direction to that which started the swing. Engage the travel swing lock or swing (park) brake only after the upper comes to a complete stop.

The travel swing lock is a four position swing lock. It can be engaged in four positions: directly over the sides or directly over the ends. The over the side position is for use when transporting the crane. The mechanically operated travel swing lock is engaged/disengaged using the control lever below and to the right of the operator's seat. Refer to Figure 1-54. To engage the travel swing lock, pull the control lever up, push it right and down. To disengage the travel swing lock, pull the lever up, push it to the left and down.

Note: In order to disengage the travel swing lock, it may be necessary to swing the upper slightly in one direction or the other to free the swing lock pin, allowing it to release.

To Swing The Upper

1. Compare the boom configuration and length to the appropriate capacity chart in the Crane Rating Manual. Position the boom safely within the limits specified on the capacity chart in the Crane Rating Manual.



DANGER

All personnel and equipment must be out of the path of the rotating upper. Failure to do so will result in serious personal injury or major equipment damage.

Swing slowly and cautiously. Watch out for centrifugal force. Out swing of a load increases the load radius which decreases capacity. Load out swing may result in tipping or damaging the crane.

2. Check that the travel swing lock control lever is in the "ENGAGED" position.
3. Move the swing (park) brake switch, on the swing control lever, to the "OFF" position. Check to see that the swing (park) brake indicator light on the service monitor is off.
4. Disengage the travel swing lock using the travel swing lock control lever below and to the right of the operator's seat.

Note: In order to disengage the travel swing lock, it may be necessary to swing the upper slightly in one direction or the other to ease the pressure on the swing lock pin, allowing it to release.

5. Move the swing control lever forward or backward to begin swinging in the desired direction. Release the control lever to neutral and allow the upper to coast as the crane approaches the desired position. Slowly engage the swing control lever in the opposite direction to that which started the swing in order to slow and then stop the upper.

CAUTION

Do not engage the travel swing lock or swing (park) brake with the upper in motion. This practice will result in damage to the swing mechanism. Stop the swinging upper by easing the swing control lever in the opposite direction to that which started the swing. Engage the travel swing lock and/or swing (park) brake only after the upper comes to a complete stop.

6. After coming to a complete stop, apply the swing (park) brake and/or travel swing lock as desired.

Operator's Manual

Steering And Traveling The Crane

Traveling the crane is controlled by the travel/steer levers. Refer to Figure 1-55. The sequence of engaging these controls is critical to ensure smooth travel operation. Travel speed is proportional to lever movement with a top speed of 1.44 mph (2.3km/h). The travel brakes are a spring applied, hydraulically released multiple disc type which are automatically applied when the travel/steer levers are returned to the neutral position. To travel and steer the crane along a firm, level route, proceed as follows:

Note: The following instructions are based on traveling the crane with the travel motors to the rear. When the travel motors are in front, the right and left travel/steer lever operations must be reversed.

1. Always take time to choose the safest, most level route. Designate a signal person to guide the operator along the route.
2. Position the upper directly over the end of the lower and engage the travel swing lock.
3. **To travel the crane forward or backward:** Push both travel/steer levers in the desired direction simultaneously. Release of the spring loaded travel levers will automatically return the levers to the neutral position and will also apply the brakes.

To steer the crane to the right: Push the left travel/steer lever forward while leaving the right travel/steer lever in the neutral position.

To steer the crane to the left: Push the right travel/steer lever forward while leaving the left travel/steer lever in the neutral position.

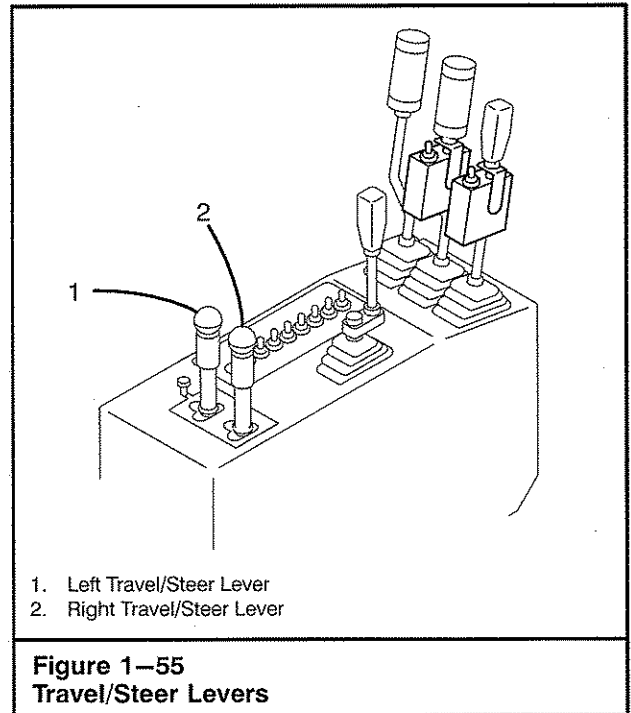

To spin turn (counter-rotate): Push one travel/steer lever forward while pulling the opposite one to the rear. The direction of rotation will depend on the direction the travel/steer levers are pushed.

To Stop: Release the steer control levers.

Operator's Manual

Operating In Wind Or Lightning

Avoid working a crane in high winds and when there is a likelihood of lightning. Rated lifting capacities do not account for the effects of wind on a suspended load or boom. Lifting capacities should be considered acceptable for wind speeds up to 20 mph (32km/h) and appropriately reduced for wind speeds greater than 20 mph (32km/h). If you must work in a wind, reduce capacities to those listed in "Wind Restrictions Guide" in the Crane Rating Manual. Wind blowing against the load and the boom produces a side load on the boom and reduces its capacity. When lifting loads which have large surface areas in a wind, such as building panels, the movement of the load may pose a danger

to workers or building structures. Out swing of a load will increase the load radius, and may overload the crane. This could lead to boom failure or the crane tipping. Monitor the wind speed using a wind speed indicator or the "Wind Scale" chart below. Stop lifting operations, ground the load, and fully lower the boom to horizontal if wind speed exceeds the maximum allowed listed in "Wind Restrictions Guide" in the Crane Rating Manual. Use the following "Wind Scale" chart as a general guide.



DANGER

If there is a likelihood of lightning, immediately stop lifting operations, ground the load, and fully lower the boom.

Wind Scale				
Wind Speed		Wind Strength		Inland Wind Effect
mph	km/h	Beaufort Scale	WMO* Description	
<0.6	<1	0	Calm	Calm, smoke rises vertically.
0.6–3.1	1–5	1	Light Air	Smoke drift indicates wind direction, wind vanes remain still.
3.7–6.8	6–11	2	Light Breeze	Wind felt on face, leaves rustle, wind vanes begin to move.
7.4–11.8	12–19	3	Gentle Breeze	Leaves and small twigs constantly moving, light flags extended.
12.4–17.4	20–28	4	Moderate Breeze	Dust, leaves, and loose paper lifted, small tree branches move.
18.0–23.6	29–38	5	Fresh Breeze	Small trees in leaf begin to sway. Crested waves form on inland waters.
62.8–30.4	39–49	6	Strong Breeze	Larger tree branches moving. Telegraph wires whistle. Umbrellas used with difficulty.
31.1–37.9	50–61	7	Near Gale	Whole trees moving. Resistance felt walking against wind.
38.5–46.0	62–74	8	Gale	Breaks twigs off trees. Resistance felt walking against wind.
46.6–54.1	75–87	9	Strong Gale	Slight structural damage. Slate blows off roofs.
54.7–62.8	88–101	10	Storm	Trees broken or uprooted. Considerable structural damage.

* World Meteorological Organization

Operator's Manual

Crane Monitoring System

The crane monitoring system is intended to aid the operator in the efficient operation of the crane.



WARNING

Although the system will alert the operator of an approaching overload or unsafe condition, it remains the responsibility of the operator to operate the crane safely at all times.

This system must not be substituted for the good judgment of the crane operator using safe operating procedures. The operator is solely responsible for safe operation of the crane.

!!THIS SYSTEM IS AN OPERATOR'S AID – NOT A SAFETY DEVICE!!

Anti-Two Block System

The anti-two block system is an electromechanical system designed to alert the operator before the hook block, hook ball, or load contacts the head machinery of the main boom or jib. When a two block situation is imminent, an audio/visual alarm is activated to alert the operator of the pending danger. When the alarm activates, it is essential that the operator discontinue operations immediately, and correct the two block situation.

Three basic components are used to make-up the anti-two block system. The anti-two block weight and head machinery switch, mounted at the head machinery, and the audio/visual alarm in the operator's cab. Refer to Figure 1–56.

Operator's Manual

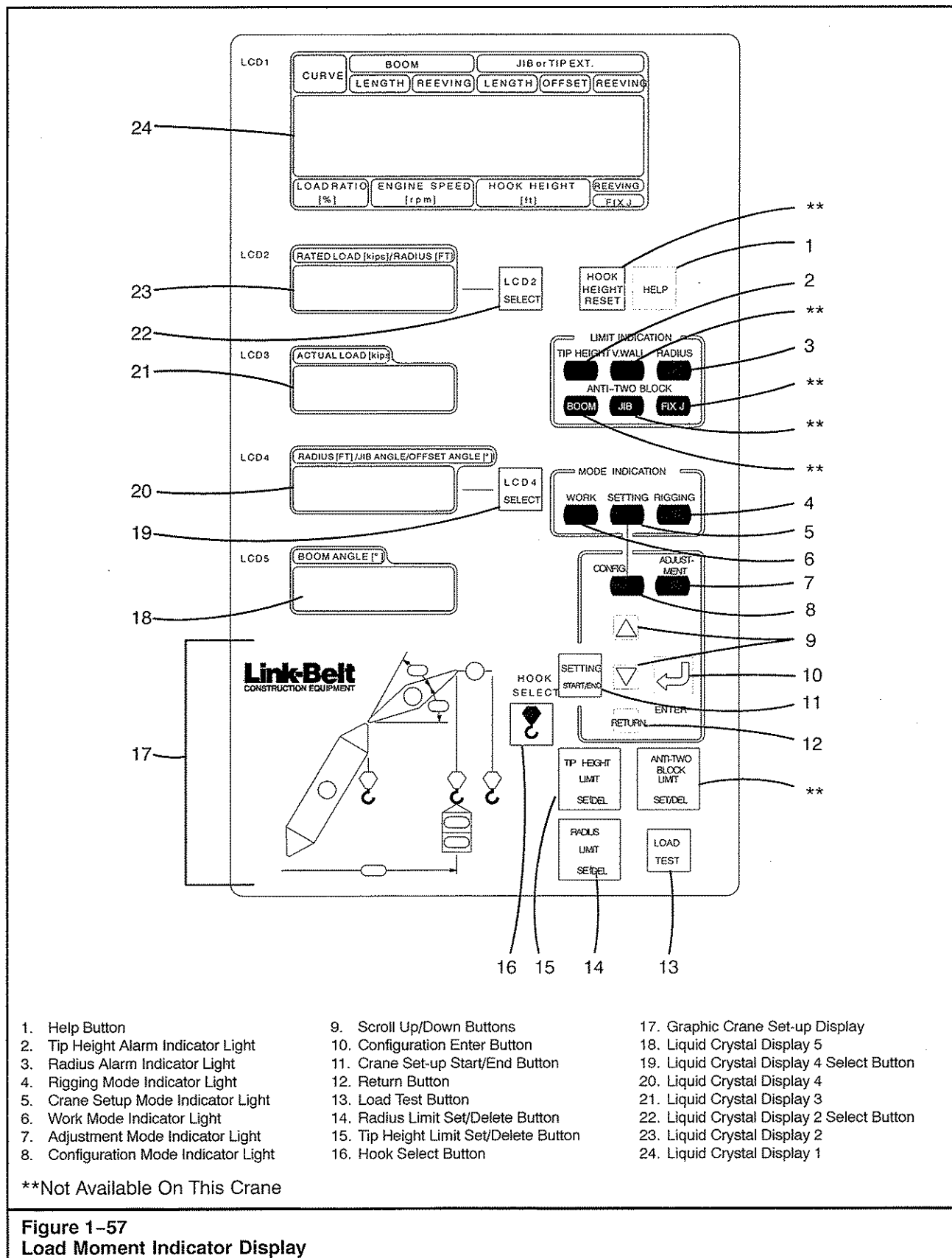

Figure 1-57
Load Moment Indicator Display

Operator's Manual

8. Configuration Mode Indicator Light

This light will illuminate to alert the operator that a configuration routine has been selected by pressing the Setting Start/End button.

9. Scroll Up/Down Buttons

Use these buttons to scroll through the available selections during configuration routines.

10. Configuration Enter Button

Use this button to select the displayed selection during configuration routines.

11. Crane Set-up Start/End Button

Use this button to start or end the crane configuration routine.

12. Return Button

Use this button to return to the previous setting during a configuration routine.

13. Load Test Button

Use this button to test the overload alarms and function limiters. Refer to "Load Test" procedure.

14. Radius Limit Set/Delete Button

Use this button to start or deactivate a radius alarm. Refer to "Operator Settable Limits" in this Section of this Operator's Manual.

15. Tip Height Limit Set/Delete Button

Use this button to set or deactivate a tip height limit. Refer to "Operator Settable Limits" in this Section of this Operator's Manual.

16. Hook Select Button

Use this button to select the hook that will be used for lifting. The hook indicator light on the graphic display will illuminate to indicate which hook has been selected as a lifting point.

17. Graphic Crane Set-up Display

The graphic crane set-up display provides the operator with a graphic representation of the crane's current configuration during the normal working mode.

The following gives a description of each indicator light within the display.

a. Jib Indicator Light

- Light illuminates when being set with the jib in the work mode.
- Light illuminates when setting the jib length in the crane set-up mode (configuration mode).

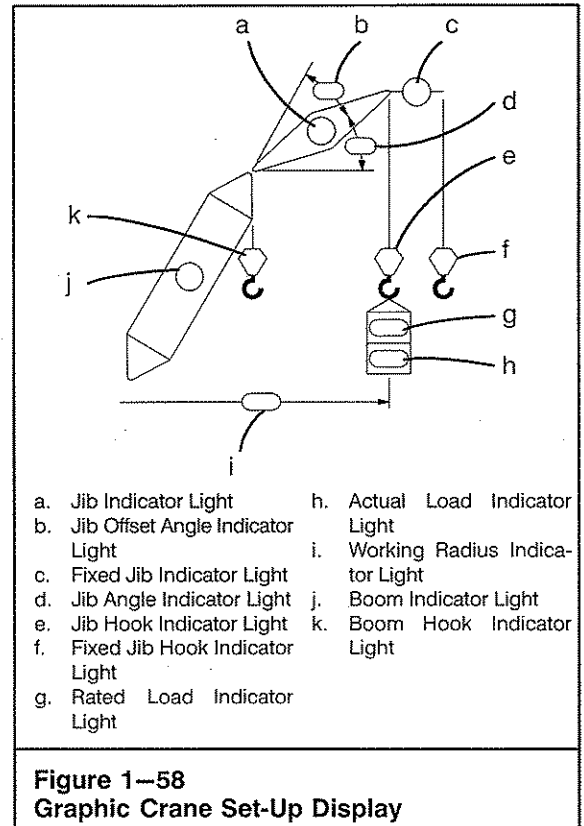

b. Jib Offset Angle Indicator Light

- Light illuminates when the offset angle is displayed on LCD4 in the work mode.
- Light illuminates when setting the jib offset angle in the crane set-up mode (configuration mode).

c. Fixed Jib Indicator Light

- Light illuminates when the fixed jib is selected in the work mode.

d. Jib Angle Indicator Light

- Light illuminates when the jib angle is displayed on LCD4 in the work mode.

e. Jib Hook Indicator Light

- Light illuminates when the jib hook is selected with the hook select switch in the work mode.
- Light illuminates when selecting the jib hook information in the crane set-up mode (configuration mode).

f. Fixed Jib Hook Indicator Light

- Light illuminates when the fixed jib hook is selected with the hook select switch in the work mode.
- Light illuminates when selecting the fixed jib hook information in the crane set-up mode (configuration mode).

Operator's Manual

- g. Rated Load Indicator Light
 - Light illuminates when the rated load is displayed on LCD2.
- h. Actual Load Indicator Light
 - Light illuminates when the actual load is displayed on LCD3.
- i. Working Radius Indicator Light
 - Light illuminates when the working radius is displayed on LCD2 or LCD4.
- j. Boom Indicator Light
 - Light illuminates when the boom angle is displayed on LCD5 in the work mode.
 - Light illuminates when selecting the boom length in the crane set-up mode (configuration mode).
- k. Boom Hook Indicator Light
 - Light illuminates when the boom hook is selected with the hook select switch in the work mode.
 - Light illuminates when selecting the boom hook information in the crane set-up mode (configuration mode).

18. LCD 5 Display

In the normal working mode and rigging mode, LCD 5 gives a continuous indication of the angle of the main boom relative to horizontal.

In the crane set up mode, the setting values are displayed.

19. LCD 4 Select Button

Press this button to toggle between "Working Radius", "Jib Angle", or "Offset Angle" displayed in LCD 4.

20. LCD 4 Display

In the normal working mode and rigging mode, LCD 4 can give a continuous indication of the working radius, the jib angle, or offset angle. Use the LCD 4 Select Button to display the desired reading.

In the crane set up mode, the setting values are displayed.

21. LCD 3 Display

In the normal working mode, LCD 3 gives a continuous indication of the total load suspended below

the boom or jib head. It includes the load, any slings, pins, or tackle used to secure the load, and the hook block, and/or hook ball. The display will go blank when the boom reaches a range where there are no capacities or the rated load is greater than 100%.

Note: All actual load data is shown in kips. When the actual load is less than 100 kips, it is displayed as a decimal e.g. 0.9 = 90 kips. (1 kip = 1000 lb.)

In the crane set up mode, the setting values are displayed.

In rigging mode, the display may be blank or "----" is displayed.

22. LCD 2 Select Button

Press this button to toggle between "Rated Load", and "Working Radius" displayed in LCD 2.

23. LCD 2 Display

In the normal working mode, LCD 2 gives a continuous indication the rated load (kips) or working radius (ft). Use the LCD 2 Select Button to display the desired reading. The display will go blank when the boom reaches a range where there are no capacities or the rated load is greater than 100%.

The rated load is derived from a copy of the crane's capacity chart which is stored in the computer memory and is the reference capacity for any lifting operation. It is dependent on the configuration currently selected, which is shown in the graphic crane setup display and which determines the section of the capacity chart to be used as the rated capacity reference.

Note: All rated load data is shown in kips and displayed to one decimal place.

In the crane set up mode, the setting values are displayed.

In rigging mode, engine speed or working status are displayed. Use the LCD 2 select button to display the desired reading.

Operator's Manual

24. LCD 1 Display

In the normal working mode, the following is displayed in LCD 1.

- a. Curve Number: The curve number selected is displayed. Refer to Crane Rating Manual for curve number.
- b. Boom Length: The boom length (ft) selected is displayed.
- c. Boom Reeving: The number of parts of line for the hook selected is displayed.
 - "0" is displayed when "None" in the boom hook weight is selected.
 - The number of parts of line for the main hook is displayed when the boom head with two hooks is selected as in the jib length.
- d. Jib Length: The jib length (ft) selected is displayed.
 - "4" is displayed when the boom tip extension is selected .
 - Nothing is displayed when "None" or the boom head with two hooks are selected.
- e. Jib Offset: The jib offset angle selected is displayed.
 - Nothing is displayed when "None", boom tip extension, or boom head with two hooks as in the jib length.
- f. Jib Reeving: The number of parts of line for the jib hook selected is displayed.
 - "0" is displayed when "None" in the jib hook weight is selected.
 - The number of parts of the auxiliary hoist line is displayed when the boom head with two hooks is selected as in the jib length.
- g. Engine Speed: The engine speed (rpm) is displayed.
- h. Load Ratio [%]: The load ratio (%) is displayed.
 - "----" is displayed when boom tip reaches a range where there are no capacities.
 - "----" is displayed when the load ratio is 100%. (override is excluded).

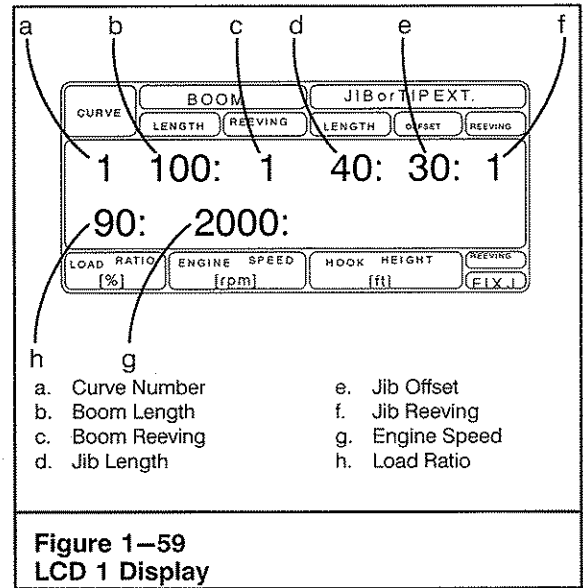

In the crane set-up mode, the setting procedure, setting item, and setting value are displayed.

In the rigging mode, the mode name and attachment setting status are displayed.

Operator's Manual

Throughout this Operator's Manual, reference is made to the left, right, front, and rear pertaining to direction and locations. These reference directions are relative to the operator sitting in the operator's seat with the travel motor to the rear, unless otherwise stated. If the side frames are removed, the jack cylinder controls are to the front of the lower frame.

Danger, warning, and caution captions, as well as special notes, are used throughout this Operator's Manual and on the crane to emphasize important and critical instructions. Labels, plates, decals, etc. should be periodically inspected and cleaned as necessary to maintain good legibility for safe viewing. **If any instruction, caution, warning, or danger labels, decals, or plates become lost, damaged, or unreadable, they must be replaced.** Information contained on such labels, decals, and plates is important and failure to follow the information they contain could result in an accident. Replacement labels, decals, and plates can be ordered through your Link-Belt Distributor. For the purpose of this Operator's Manual, and the labels which are placed on the crane, danger, warning, and caution captions and notes are defined as follows:



DANGER

An operating procedure, practice, etc. which, if not correctly followed, may result in serious personal injury, dismemberment, or loss of life.



WARNING

An operating procedure, practice, etc. which, if not correctly followed, may result in personal injury.

CAUTION

An operating procedure, practice, etc. which, if not correctly followed, may result in damage to or destruction of equipment or property.

NOTE

Note: An operating procedure step, condition, etc. which is essential in order for the process to be completed properly.

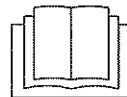

This symbol may appear in this Operator's Manual or on a label on the crane to alert personnel that additional instructions are included in this crane Operator's Manual.

Operator's Manual

Mode Name		Function
Working Mode	Normal	This is the normal operating mode for all lift crane applications.
	Override	This mode is used when performing duty cycle work with a clamshell or drag-line attachment. If the crane is overloaded while operating in this mode, the alarm will sound and function limiters are activated. The alarm cannot be released.
Crane Set-Up Mode	Configuration	This is the mode to select the current crane configuration.
	Adjustment	This is the mode to confirm the adjustment of the Load Moment Indicator and the operation of the function limiters.
Rigging Mode	Rigging	This mode allows 1) the assembling and disassembling of the crane; 2) raising and lowering of the boom when maximum radius is exceeded. The function limiters will automatically return to active status once the crane boom or luffing jib (not applicable to this crane) enters an allowable working radius.
	Crane	This mode allows the attachment to be raised or lowered to the ground after the crane attachments are assembled to the upper and the LMI electrical connections between the boom and upper are made.
Maintenance Mode		For Service Use Only
Inspection Mode		For Service Use Only

System Operation

The following is a list of procedures which are used to operate the multiple features of the LMI. Use these procedures in conjunction with the previous display unit control descriptions.

System Inoperative Or Malfunctioning

When operational aids are inoperative or malfunctioning, the following recommendations for continued use of the crane should be followed or the crane should be shutdown.

- Steps shall be taken to schedule repairs and recalibration immediately. The operational aids shall be put back into service as soon as replacement parts, if required, are available and the repairs and recalibration can be carried out. Every reasonable effort must be made to expedite the repairs and recalibration.
- When the LMI is inoperative or malfunctioning, the designated person responsible for supervising the lifting operations shall establish procedures for determining load weights and shall ascertain that the weight of the load does not exceed the crane ratings at the radius where the load is to be handled.
- When a boom angle or radius indicator is inoperative or malfunctioning, the radius or boom angle shall be determined by measurement.
- When the anti-two block warning device is inoperative or malfunctioning, the designated person responsible for supervising the lifting operations shall establish procedures, such as assigning an additional signal person, to furnish equivalent protection. This does not apply when lifting personnel in load line supported baskets. Personnel shall not be lifted in load line supported baskets when the anti-two block devices are not functioning properly.
- When a level indicator is inoperative or malfunctioning, other means shall be used to level the crane.
- In situations where inconsistency exists, verified weights, measured radii, boom lengths, and authorized crane capacities must always take precedence over indicator readings.

Operator's Manual

Configuration Selection

In the normal operational mode, the system is programmed to remember the last configuration selected. Each time the system is powered up it will automatically choose that configuration. Only when the crane is rigged differently must a new configuration be selected. Use the following procedure to select the crane configuration



WARNING

The Load Moment Indicator must be set correctly. Incorrect settings may result in an unsafe working condition.

1. With the control levers in the "Neutral", and from the normal working screen, press the SETTING START/END button. "CONFIGURATION" will now be displayed in LCD1. The Crane Setup Mode Indicator and Configuration Mode Indicator lights will illuminate.

Note: The crane set-up mode cannot be started if the control levers are not placed in the "Neutral" position. If the levers are not in the "Neutral" position, "Set Lever in Neutral" is displayed in LCD1.

2. Press the ENTER button when "CONFIGURATION" is displayed in LCD1 to start the configuration routine.

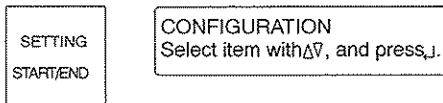

3. LCD1 will now prompt for the the curve number. Press the UP/DOWN buttons to scroll through the curve numbers. Refer to the Crane Rating Manual for curve definitions.
4. When the desired curve number appears, press the ENTER button to select that curve number.

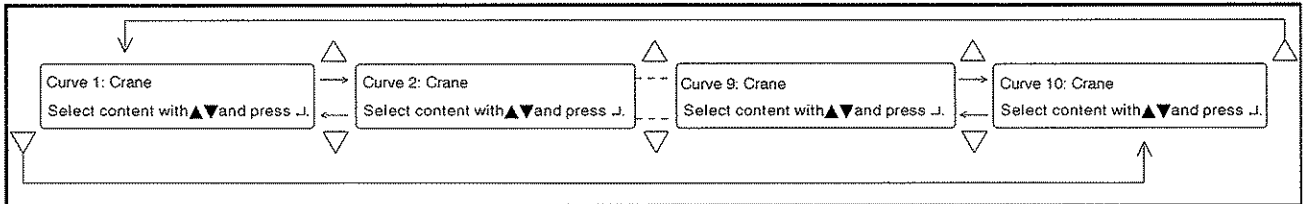

5. LCD1 will now prompt for the boom length. Press the UP/DOWN buttons to scroll through available boom lengths.
6. When the desired boom length appears, press the ENTER button to select that boom length. The Boom Indicator Light in the graphic crane setup display will illuminate.

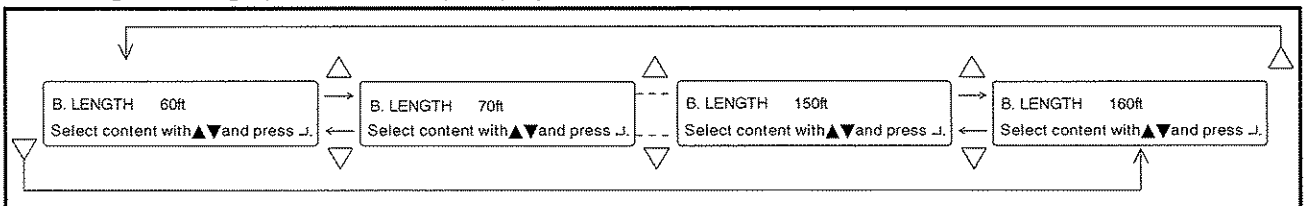

7. Boom hook "Present" or "None" is displayed in LCD1. Press the UP/DOWN buttons to display "Present" or "None".
8. Press the ENTER button to select boom hook present or none. If boom hook present was selected, the Boom Hook Indicator Light in the graphic crane setup display will illuminate.



Operator's Manual

9. LCD1 and LCD2 will now prompt for the drum for the boom hook. Press the UP/DOWN buttons to scroll through available winch drums.
10. Select the drum corresponding to the boom hook by pressing the ENTER button.

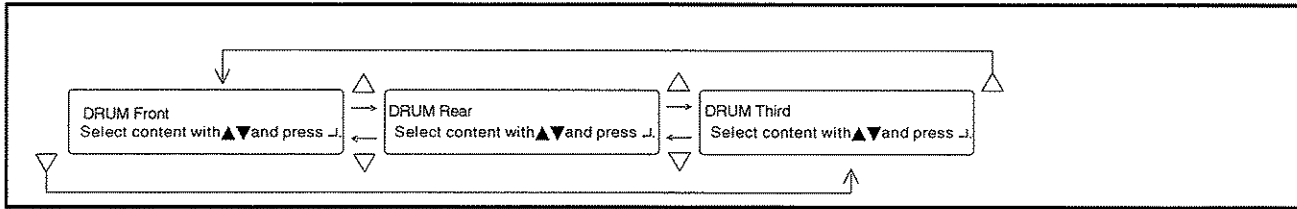

11. LCD1 and LCD2 will now prompt for the boom hook reevings. The Boom Hook Indicator Light in the graphic crane setup display will illuminate.
12. Press the UP/DOWN buttons to scroll through available boom hook reeving values.
13. Press the ENTER button to select boom hook reeving.

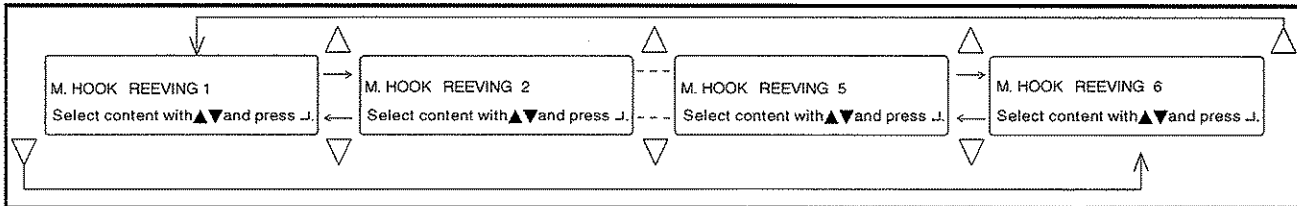

14. LCD1 and LCD2 will now prompt the standard boom hook block/hook ball capacity ratings. Displayed in kips for the hook block/hook ball capacity ratings.
15. Press the UP/DOWN buttons to scroll through available boom hooks.
16. Press the ENTER button to select boom hook capacities.

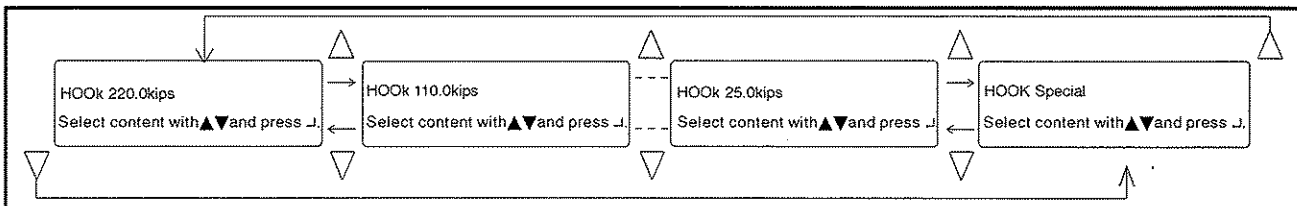

Note: If the hook block/hook ball was purchased from Link-Belt, make hook selection according to hook block/hook ball capacity. i.e. 2200 kips = 110 ton hook.

17. If the hook was not purchased from Link-Belt, select "Special". When "Special" is selected, the weight of the hook must be input manually. Hook capacity does not apply to "Special" hook blocks/hook balls in LMI configuration.
 - a. Press the ENTER button when "Special" is displayed in LCD1.
 - b. Press the UP/DOWN buttons until the weight of the special hook is displayed in LCD1 and press the ENTER button.

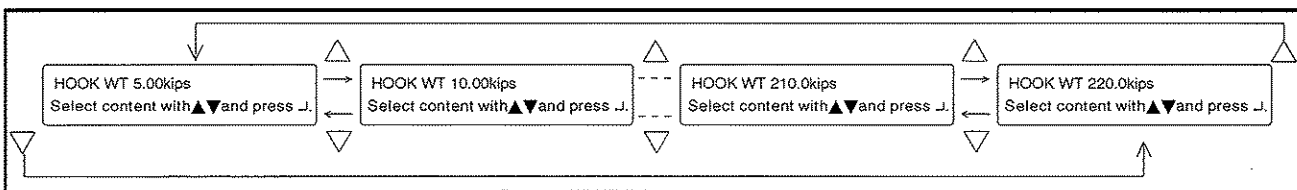

18. LCD1 and LCD2 will now prompt Jib Present, Jib None or Jib Two Hooks.
19. Press the UP/DOWN buttons to scroll through available attachments.

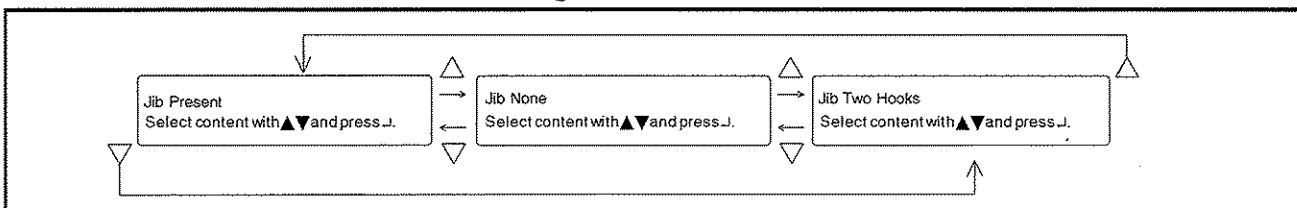

Operator's Manual

20. If Jib Present was selected, LCD1 will display Jib Length. Press the UP/DOWN buttons to scroll through available jib lengths.
21. When the desired jib length appears in LCD2, press the ENTER button to select that jib length. The jib Indicator Light in the graphic crane setup display will illuminate. Selecting 4 ft = the tip extension.

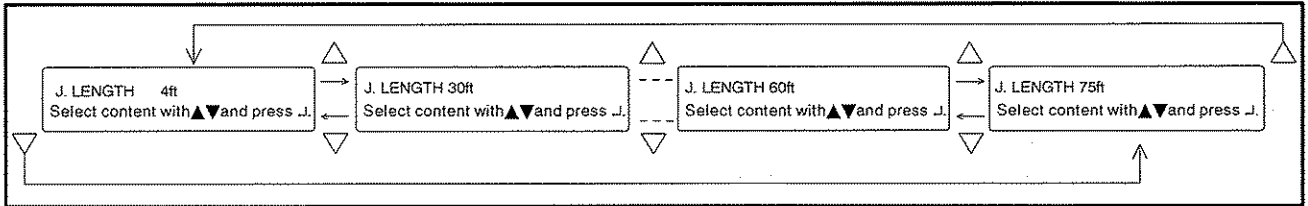

22. LCD1 and LCD2 will now prompt the Jib Offset.
23. Press the UP/DOWN buttons to scroll through available jib offset angles.
24. When the desired jib offset appears in LCD2, press the ENTER button to select that jib offset. The jib Offset Indicator Light in the graphic crane setup display will illuminate.

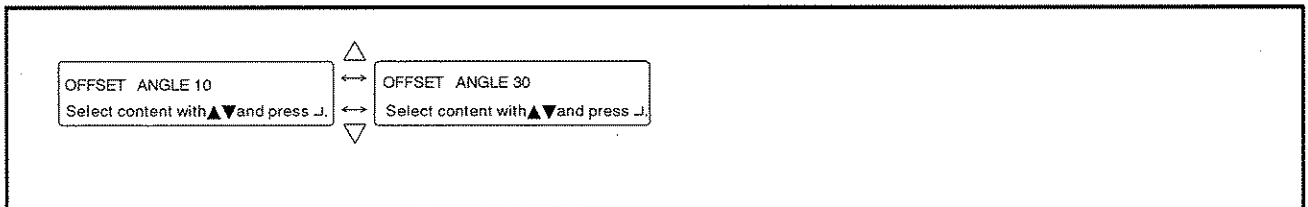

25. Jib hook "Present" or "None" is displayed in LCD1. Press the UP/DOWN buttons to display "Present" or "None".
26. Press the ENTER button to select jib hook present or none. If jib hook present was selected, the Jib Hook Indicator Light in the graphic crane setup display will illuminate.

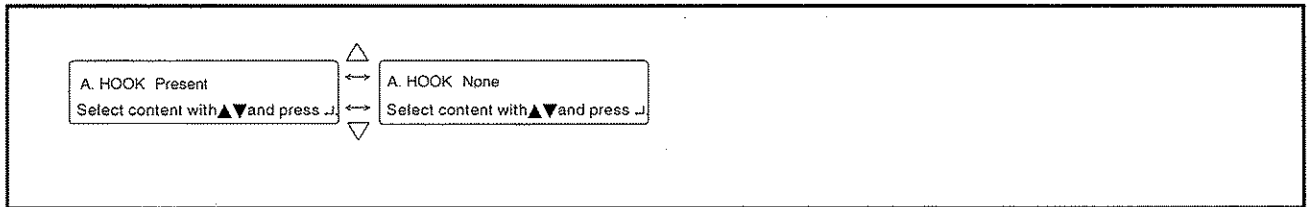

27. LCD1 and LCD2 will now prompt a drum for jib hook. Press the UP/DOWN buttons to scroll through available winch drums.
28. Select the drum corresponding to the jib hook by pressing the ENTER button.

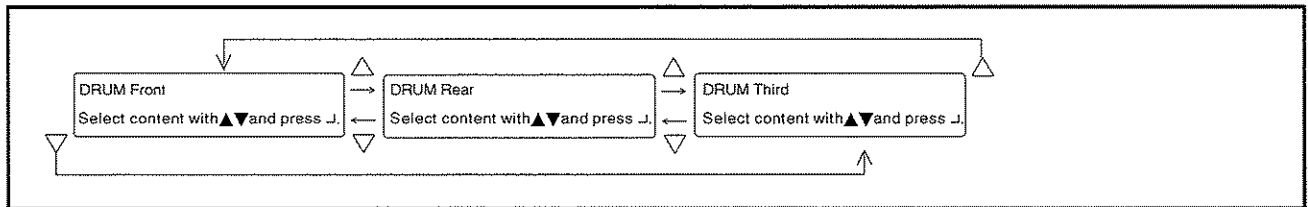

29. LCD1 and LCD2 will now prompt jib hook reevings. The Jib Hook Indicator Light in the graphic crane setup display will illuminate.
30. Press the UP/DOWN buttons to scroll through available jib hook reeving values.
31. Press the ENTER button to select jib hook reeving.

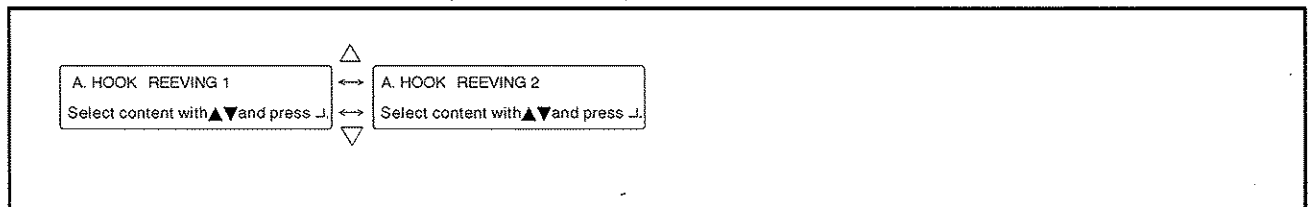

Operator's Manual

32. LCD1 and LCD2 will now prompt standard jib hook weights.
 33. Press the ENTER button to select jib hook weights.

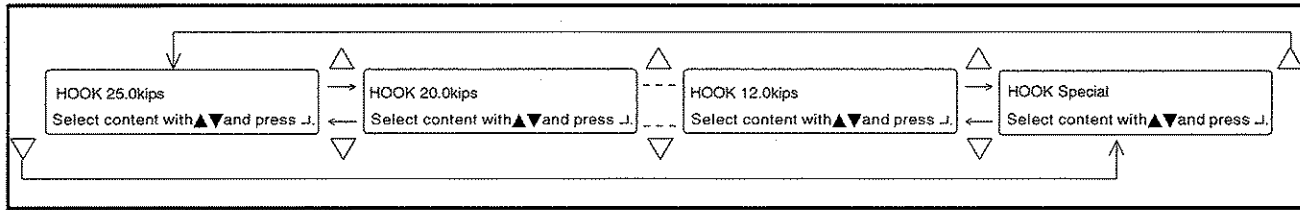

Note: If the hook block/hook ball was purchased from Link-Belt, make hook selection according to hook block/hook ball capacity. i.e. 2200 kips = 110 ton hook.

34. If the hook was not purchased from Link-Belt, select "Special". When "Special" is selected, the weight of the hook must be input manually. Hook capacity does not apply to "Special" hook blocks/hook balls in LMI configuration.
- Press the ENTER button when "Special" is displayed in LCD1.
 - Press the UP/DOWN buttons until the weight of the special hook is displayed in LCD1 and press the ENTER button.

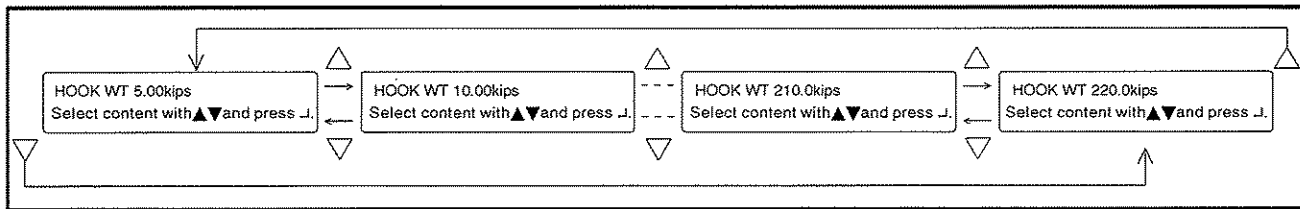

35. When setting is complete, it is automatically shifted to the mode (Rigging mode, Crane mode, and Work mode) before starting the crane set-up mode.

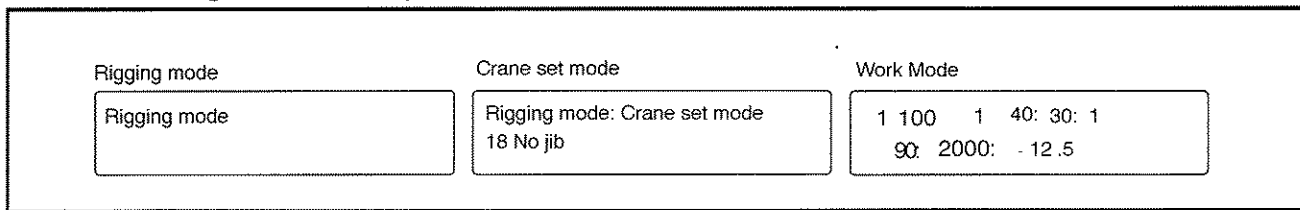

Operator's Manual

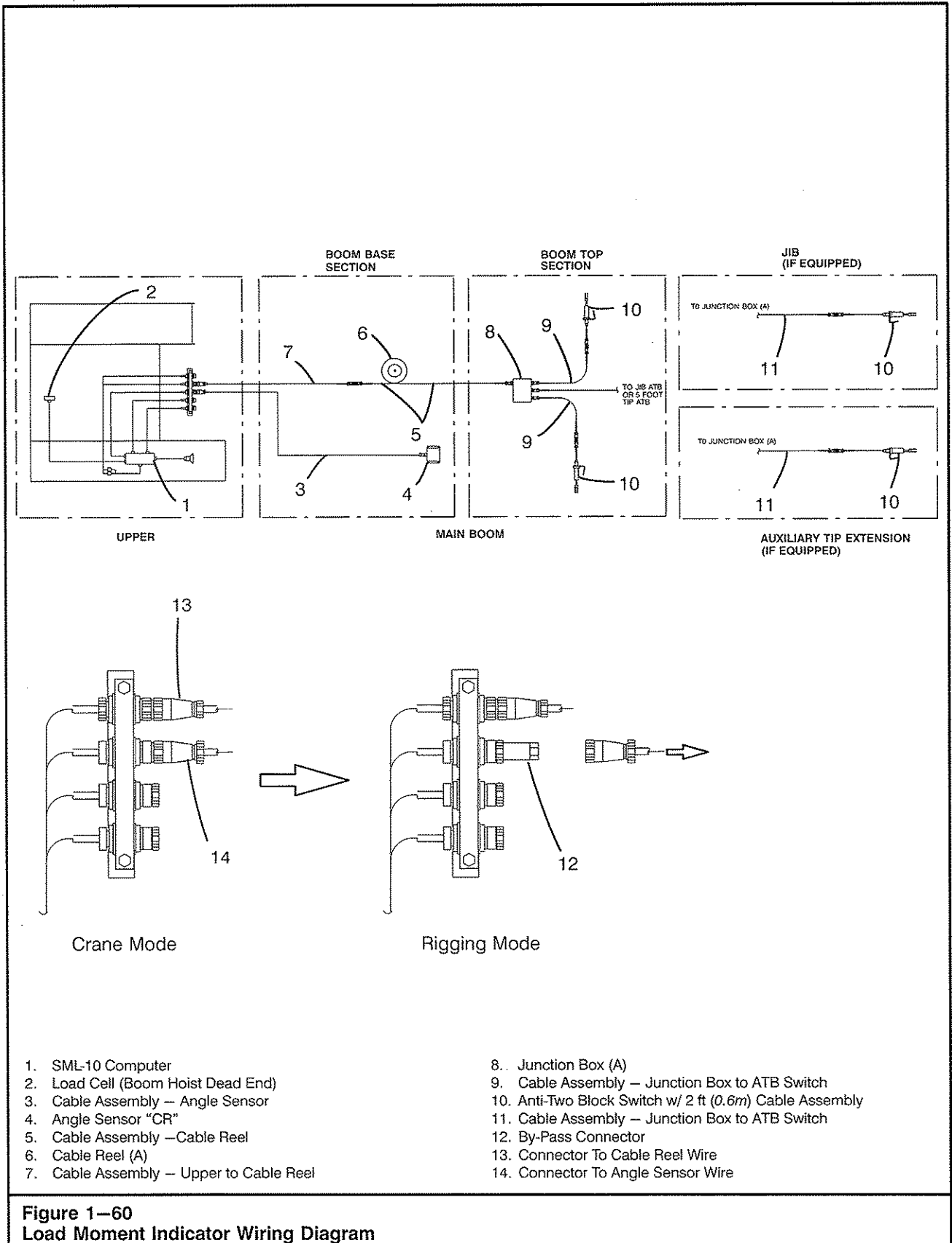

Figure 1-60
Load Moment Indicator Wiring Diagram

Operator's Manual

Rigging Mode

This crane is equipped with a "Rigging Mode". This mode is used when disassembling, assembling, and raising and lowering the crane attachment. There are three modes in the rigging mode. Rigging mode is selected using the switch on left control console.



WARNING

The function limiters are not operational when in the RIGGING Mode. Return the SML-10 to normal operation before operating the crane.

Rigging Mode

This mode relates to the disassembly/assembly of the attachment when the electrical wiring for the load cell (tension detector), angle indicator, etc. are disconnected and the by-pass connector is installed.

Crane Mode – with crane attachment

This mode relates to raising the attachment to the working position after assembling the crane attachment, connecting the electric wirings of the load cell (tension detector), angle indicator, etc., and removing the by-pass connector. This mode relates to lowering the attachment to the ground from the working position.

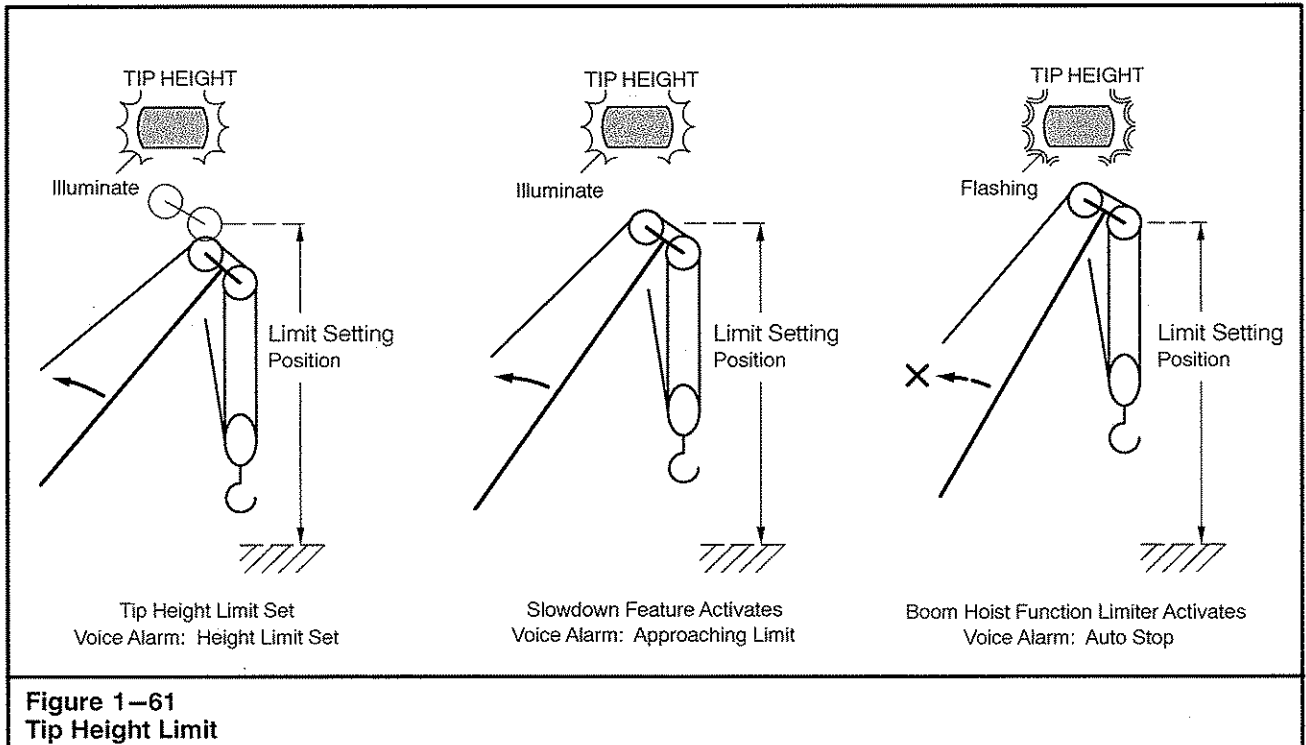

Operator Settable Limits

Some limits occur automatically as a result of limitations imposed by the capacity chart. The operator has control over additional limits which can be set to operate within the normal chart limitations and which are, in addition to, those already limited by the capacity charts in the Crane Rating Manual.

Operator settable limits will be stored in the computer memory, even if the crane is shutdown, until they are cleared.

Two limits are available for operator use.

Tip Height Limit
Radius Limit

Setting Tip Height Limit

A boom tip height limit can be set to stop boom hoist function at a preset point determined by the operator. The Tip Height Limit Indicator light will illuminate when a tip height limit is set and activated. As the boom approaches the the set limit, the slowdown feature activates and the voice alarm "Approaching Limit" sounds. When the boom reaches the set limit, the boom hoist function limiter activates, the Tip Height Limit Indicator light flashes, and the voice alarm "Auto Stop" sounds.

1. Place the boom in the desired position. The numerical value displayed in LCD5 will be the current position of the boom.

2. From the normal working screen and with the control levers in neutral, press the Tip Height Limit Set/Del button. The Tip Height Limit Indicator light flashes and the voice alarm "Height Limit Set" sounds.

CAUTION

A sudden automatic stop may occur if the lever is not placed in the "Neutral" position. Crane damage may occur if a limit set button is pushed with the control lever in any other position other than neutral. Place control lever in "Neutral" before pressing a limit set button.

3. Once the Height Limit Set/Del button is pushed, the boom cannot be raised beyond that point. Lower the boom to silence the voice alarm.
4. Lowering the boom will also stop the indicator light from flashing and allow the light to remain illuminated.
5. To delete the height limit, push the Tip Height Limit Set/Del button when the Tip Height Limit Indicator light is illuminated.

Operator's Manual

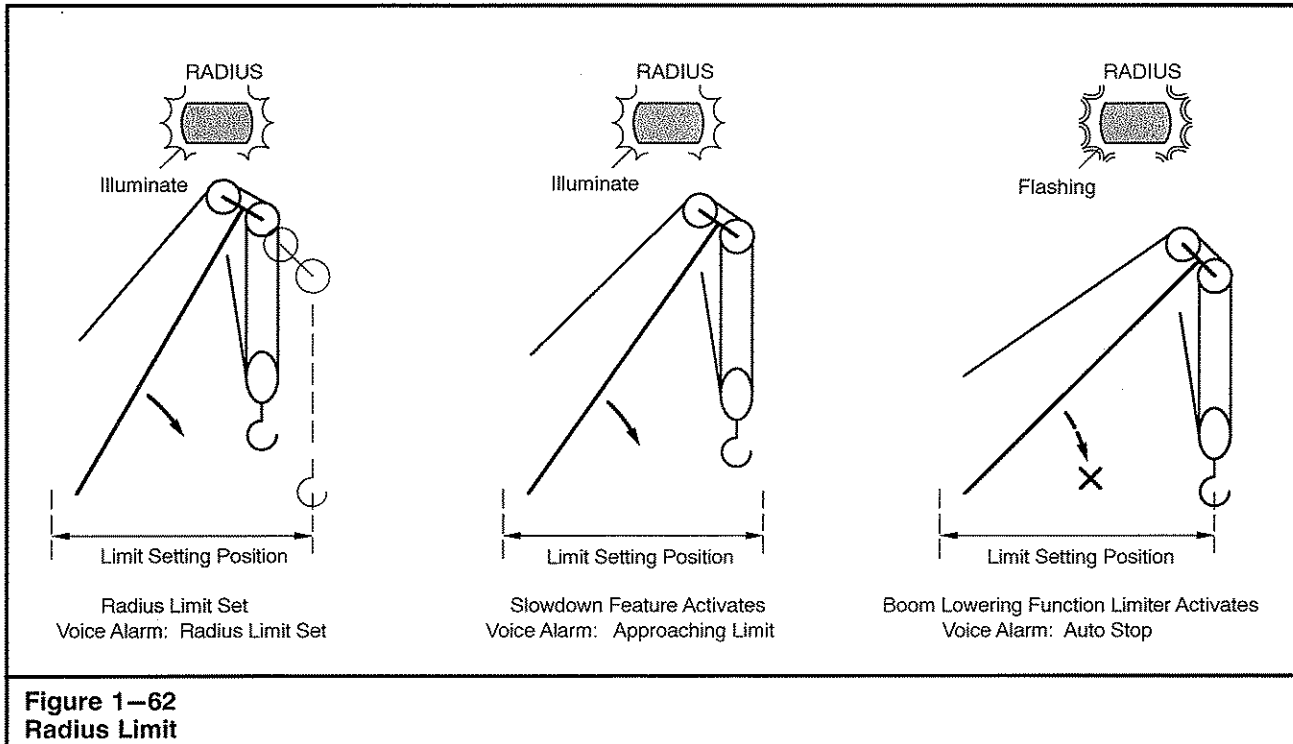

Figure 1-62
Radius Limit

Setting Radius Limit

A boom radius limit can be set to stop boom lowering function at a preset point determined by the operator. The Radius Limit Indicator light will illuminate when a radius limit is set and activated. As the boom approaches the the set limit, the slowdown feature activates and the voice alarm "Approaching Limit" sounds. When the boom reaches the set limit, the boom lowering function limiter activates, the Radius Limit Indicator light flashes, and the voice alarm "Auto Stop" sounds.

1. Place the boom in the desired position. The numerical value displayed in LCD4 will be the current position of the boom.
2. From the normal working screen and with the control levers in neutral, press the Radius Limit Set/Del button. The Radius Limit Indicator light flashes and the voice alarm "Radius Limit Set" sounds.

CAUTION

A sudden automatic stop may occur if the lever is not placed in the "Neutral" position. Crane damage may occur if a limit set button is pushed with the control lever in any other position other than neutral. Place control lever in "Neutral" before pressing a limit set button.

3. Once the Radius Limit Set/Del button is pushed, the boom cannot be lowered beyond that point. Raise the boom to silence the voice alarm.
4. Raising the boom will also discontinue the indicator light from flashing and allow the light to remain illuminated.
5. To delete the radius limit, push the Radius Limit Set/Del button when the Radius Limit Indicator light is illuminated.

Operator's Manual

Overload Test

This test is achieved by using the Load Test Button. It is done to confirm that the system will function properly during an overload condition. This test can only be done while in the normal working mode.

1. Move the gate lock lever to the "Operate" position.
2. Ensure that the Low Control Pressure indicator light on the service monitor goes out.

3. Ensure that the Master Control Override Switch is in the "DISABLE" position.
4. Continually push the load test button. Each time the button is pushed, the load ratio reading in LCD1 will increase. Confirm that the following occurs at each load ratio interval.

Items	Load Ratio			
	<90%	90% ≤ 99%	100% ≤ 119%	≥ 120%
Exterior Light Bar	Green light illuminates Will not function in override mode.	Yellow light illuminates	Red light illuminates	
Voice Alarm		"Auto Stop" is sounded. Only sounded when control is in "Lower" position.	"Overload Limit" is sounded. Cannot be canceled using override switch.	
Slowdown Feature		Activates only when boom control is in the "Lower" position. Will not function in override mode.		
Function Limiter			Activates in boom lowering and winch up. Cannot override.	
Display				Load ratio, rated capacity, and actual load are canceled (blank).
Buzzer Alarm				Continuous

Operator's Manual

General Index

A detailed Table Of Contents for each Section of this Operator's Manual is included at the beginning of each Section. The following is a description of each Section:

Section 1 – Operating Instructions Pages 1–1 Thru 1–120

Section 1 includes the necessary information for safe, productive crane operation. It includes the nomenclature and operation of all control switches, levers, pedals, and instrumentation of the crane.

Section 2 – Lubrication And Preventive Maintenance Pages 2–1 Thru 2–28

Section 2 includes the necessary information for proper lubrication and preventive maintenance for daily operations. It includes the check/change intervals and procedures for maximizing the service life of the crane under normal working conditions. It also includes lubrication types and specifications approved for use in the crane.

Section 3 – Periodic Adjustments Pages 3–1 Thru 3–16

Section 3 includes the adjustments which must be made periodically to keep the crane in proper, safe working order. It includes the procedures and necessary information for adjusting the brakes, mechanical linkages, and hydraulic pressures on the crane.

Section 4 – Attachments Pages 4–1 Thru 4–24

Section 4 includes the use and operation of the crane attachments. It includes the necessary information for installation, erection, storage, and removal of the boom and jib.

Section 5 – General Information Pages 5–1 Thru 5–32

Section 5 includes general information on the Crane Rating Manual and serial number used for the crane. It also includes general information on wire rope specifications, inspection, replacement, connections, reeving, and general specifications used for the crane.

Section 6 – Fundamental Terms Pages 6–1 Thru 6–6

Section 6 includes a list of terms which are used to refer to crane functions, assembly, operation, and maintenance. These terms are defined as to how they are used in this Operator's Manual.

Operator's Manual

Help Function

Pressing the help function will display a message in the upper portion of LCD1. Refer to the following chart for explanation of the message. When using the help function all other buttons are disabled. Press the help button again to return to original menu.

CRANE STATUS		HELP MESSAGE <small>(Displayed at the upper row on LCD1)</small>	EXPLANATION
1 When there are no errors and safety devices for the moment limiter are functioning properly			
		Crane functions properly.	-----
2 When the safety devices of the moment limiter function.			
Overload stop	Overload	It is stopped automatically by overload.	Dangerous condition. Carefully return crane to a safe operating condition.
	Overload Limit	It is stopped automatically by limit overload	
	Limit working radius	It is stopped automatically by limit working radius.	
	Line pull limit	It is stopped automatically by line pull limit.	
Boom angle limit	Boom angle upper limit	It is stopped automatically by boom angle upper limit.	
	Boom angle lower limit	It is stopped automatically by boom angle lower limit.	
	Luffing boom angle upper limit. (Not applicable to this crane.)	It is stopped automatically by luffing boom angle upper limit.	
	Luffing boom angle lower limit. (Not applicable to this crane.)	It is stopped automatically by luffing boom angle lower limit.	
	Boom angle upper limit switch	It is stopped automatically by boom angle upper limit limit switch.	
Jib angle limit	Jib angle upper limit	It is stopped automatically by jib angle upper limit.	
	Jib angle lower limit	It is stopped automatically by jib angle lower limit.	
	Jib angle upper limit switch	It is stopped automatically by jib angle upper limit limit switch.	
Offset angle limit for luffing jib. (Not applicable to this crane.)		It is stopped automatically by jib offset angle limit.	
Boom protection device		It is stopped automatically by boom protection device.	
Free mode	Free mode interlock	It is in free mode.	The mode will be changed from "Auto brake" to "Free". Work with caution.
	Free-fall alarm	When control lever is in neutral, hook will free-fall.	The free-fall is done when placing the winch lever in "Neutral" position. Work with caution.

Operator's Manual

CRANE STATUS		HELP MESSAGE <small>(Displayed at the upper row on LCD1)</small>	EXPLANATION
Anti two-block		It is stopped automatically by anti two-block limit switch.	Dangerous condition. Carefully return crane to a safe operating condition.
Range limit	Radius limit	It is stopped automatically by radius limit.	
	Tip height limit	It is stopped automatically by tip height limit.	
	Anti two-block limit	It is stopped automatically by anti two-block limit.	
Slow down before each automatic stop (When the voice alarm of "Auto Stop" is sounded.)		It is slowed down automatically by slow down device.	About to stop automatically by the safety device. Work with caution.
3.1 When any error occurs during the inputting of information.			
		Please check drum layer/row number.	In "Setting of drum layer/row number" of the setting mode, confirm the layer and row numbers of the wire rope and enter the correct information. When it is not returned even if they are set correctly, contact your Link-Belt Distributor.
		Something is wrong with boom tension signal.	Contact your Link-Belt Distributor.
		Something is wrong with jib tension signal.	
		Something is wrong with boom angle signal.	
When any error occurs in the jib angle indicator signal. (When "E-13" or "E-27" is displayed on LCD3.)		Something is wrong with jib angle signal.	
When any error occurs in the grip controller signal.		Something is wrong with grip controller signal.	
When any error occurs in the throttle motor signal.		Something is wrong with throttle motor signal.	
When any error occurs in the rack sensor signal.		Something is wrong with rack sensor signal.	
When any error occurs in the power source of each sensor. (When "E- 25" is displayed on LCD3.)		Something is wrong with power supply sensor.	
		Please check boom and jib angle sensor wiring.	Confirm the connection of the angle indicator. When it is not returned even if connecting the angle indicator, contact your Link-Belt Distributor.

Operator's Manual

CRANE STATUS	HELP MESSAGE (Displayed at the upper row on LCD1)	EXPLANATION
<p>— — — When the crane attachment is mounted, the curve data is set as "Luffing".</p> <p>— — — When the luffing attachment is mounted, the curve data is set as "Crane". (Not applicable to this crane.)</p>	Attachment mode signal does not agree with selection of curve data.	After setting the curve data corresponded to the attachment information programmed into the setting mode (configuration mode), set the attachment information correctly.
When any error occurs at detecting the boom hoist lever.	Something is wrong with detection of boom hoist control lever.	Contact your Link-Belt Distributor.
When any error occurs at detecting the rear drum lever.	Something is wrong with detection of rear drum control lever.	
When any error occurs at detecting the front drum lever.	Something is wrong with detection of front drum control lever.	
When any error occurs at detecting the 3rd drum lever.	Something is wrong with detection of third drum control lever.	
3.2 When any problem occurs		
When the curve data does not select the "Crane", the LMI Override Switch is in "ON" position with the crane attachment installed. (When "S- 38" is displayed on LCD3.)	Please select curve data of crane.	After setting the curve data of "Crane" in the setting mode (configuration mode), set the attachment boom make-up.
When any error occurs in the throttle motor control.	Something is wrong with throttle motor control.	Contact your Link-Belt Distributor.
When any error occurs at detecting the engine speed.	Something is wrong with detection of engine speed.	
<p>When the attachment make-up set in the setting mode (configuration mode) is incorrect. (When "E-50" is displayed on LCD3.)</p> <p>— — — — — The data does not have the make-up set of the curve data, boom length, boom hook drum, jib length, jib hook drum, and offset angle.</p>	Incomplete data. Please set crane configuration again.	Ensure that the curve data, boom length, boom hook drum, jib length, jib hook drum, and offset angle are set corresponded to the program in the setting mode, and reset if the setting is incorrect. When it is not returned even if they are set correctly, contact your Link-Belt Distributor.
When any error occurs in each memorized data.	Something is wrong with memory.	Contact your Link-Belt Distributor.
When any error occurs in the control displayed.	Something is wrong with display.	
When the overflows occur in the process of calculating.	Overflowed during calculation.	

Operator's Manual

CRANE STATUS	HELP MESSAGE <small>(Displayed at the upper row on LCD1)</small>	EXPLANATION
4 When the message displayed on LCD1.		
When setting of the curve data is incorrect, when changing the rigging mode to the crane/ luffing setting mode. — — — When the luffing attachment is installed, the curve data is set as "Crane". (Not applicable to this crane.)	Set curve selection correctly.	After setting the curve data corresponded to the attachment information programmed into the setting mode (configuration mode), set the attachment information correctly.
When the back-up battery capacity is too Low.	Replace battery.	
When maintenance to the S/C controller is required.	It is necessary for S/C CONTROLLER to be inspected.	Contact your Link-Belt Distributor.
When any error occurs with the drum rotation indicator using the hook anti two-block limit.	Something is wrong with detection of drum speed.	Stop using the hook hoisting limit and contact your Link-Belt Distributor.
5 When the "HELP" function is not applied.		
		Cannot indicate HELP message.
		In the mode that this message is displayed, the HELP message is not corresponding. Again push the HELP switch to return to the original position.

Operator's Manual

Inspection

Make a monthly inspection, in addition to the daily inspections, to ensure the SML-10 Load Moment Indicator System is functioning correctly and safely.

Inspect and adjust the Load Moment Indicator after placing the crane on a firm, level supporting surface.

Daily Inspection

1. Inspect for errors in the functioning of the Load Moment Indicator System. If any problems are found, correct immediately, or contact your Link-Belt Distributor for assistance.
2. Inspection of LCD and lamps of the display.
 - a. Check the display console for faulty lamps and LCD displays. Replace faulty lamps and LCD displays as required.
 - b. Confirm that the contents displayed in LCD1 agrees with the attachment configured.
 - c. Confirm that the working limits and lamps are set correctly.
3. Inspect the function of the boom angle upper limit for any errors. Refer to "Confirmation of upper limit function of the boom angle".
4. Inspect the various limit functions to verify that they are working properly.
 - a. Inspect the minimum oil flow of the pump, with the engine at idle.
 - b. Inspect each working limit to ensure the corresponding lamp illuminates.
 - c. Operate the crane to verify each of the limits selected are functioning properly.
 - d. Confirm the crane functions stop at the limit set and the lamp flashes for the corresponding limit.
5. Inspect the overload function for any errors. Refer to "Overload Test" in this Section of this Operator's Manual.
6. Inspect the voice alarm for errors.

Reset any of the above settings that are not set correctly. If the system is not set correctly, the Load Moment Indicator will not function properly.

Monthly Inspection

If the specified values selected for the working configuration of the Load Moment Indicator are not set correctly, the following items cannot be checked properly. If any error is found, contact your Link-Belt Distributor for assistance.

Inspection of angle indicator

1. Select the boom hook with the hook select switch. (If the boom hook is not installed, select the jib hook.)

2. Display the lifting capacities on LCD2 with the LCD2 select button.
3. Display the radius in LCD4 with the LCD4 select button.
4. Raise the boom close to the maximum working angle.
5. Measure the working radius of the boom hook.

Note: If the boom hook is not installed, measure the working radius of the jib hook.

Note: The working radius is the distance from the centerline of rotation to the centerline of the hook block/hook ball.

6. Calculate an error between the measured radius and the radius displayed on LCD4.
 $(\text{Measured} - \text{Displayed}) / \text{Measured} \times 100 = \text{Error \%}$
7. Lower the boom close to the minimum working angle.

Note: When the boom cannot be lowered to the minimum working radius, lower the boom as far as possible.

8. Measure the working radius of the boom hook.

Note: When the boom hook is not installed, measure the working radius of the jib hook.

Note: The working radius is the distance from the centerline of rotation to the centerline of the hook block/hook ball.

9. Calculate an error between the measured radius and the radius displayed on LCD4.
 $(\text{Measured} - \text{Displayed}) / \text{Measured} \times 100 = \text{Error \%}$
10. When calculated radius error exceeds a value shown below, make the angle/radius adjustment, and self-weight adjustment in the setting mode (adjustment).

Note: Refer to "Boom Radius/Angle Adjustment" and "Self-weight Adjustment" in this Section of this Operator's Manual.

Boom Angle	>75°	60-75°	<60°
Error	7%	4%	2%

Function Accuracy Inspection

11. Prepare a load of a known, verified weight.

Operator's Manual

- A: With approximately 70% of lifting capacities displayed in Step 5, prepare to lift the known load.
- B: If there is no "A" above, With approximately 100% of lifting capacities displayed in Step 7, prepare a new load with a known, verified weight.
- C: If there is no "A" and/or "B" above, prepare a new load with a known verified weight. Place the known load within a safe working range so as not to overload the crane.
12. Lift the known load.
 13. Raise the boom until the load ratio is 90% or less.
 14. Lower the boom at its slowest speed.

Note: If the boom is not automatically stopped with a light load, lower the boom until the load ratio increases.

Note: With the load hoist stopped, lower the boom until the boom stops automatically. When the boom is automatically stopped with the load;

15. Measure the radius. (R0)
16. Determine the radius at the actual load (hook and sling wire + load) from the lifting capacities table. (R)
17. Calculate the radius accuracy.
 $(R-R0) / R \times 100 = \text{Radius accuracy \%}$
18. Confirm that the radius accuracy is 10% or less.

When the boom is not automatically stopped with the load;

19. Measure the radius.
20. Determine the lifting capacity at the measured radius from the lifting capacities table. (W)
21. Determine the actual load (hook and sling wire + load). (W0)
22. Calculate the Capacity accuracy.
 $(W0-W) / W \times 100 = \text{Capacity accuracy \%}$
23. Confirm that the capacity accuracy is within +10%/– 0%

Note: If function accuracy exceeds 10% or is less than 0%, contact your Link-Belt Distributor for assistance.

Periodic Replacement Of The Internal Dry Cell Battery

There is a battery installed in the amplifier of the Load Moment Indicator. Replace this battery with a new battery every 2 years. If the battery capacity is too low, the Load Moment Indicator will not function correctly. When the battery voltage is below a standard value, replace battery. Acknowledge message, and press "J." is displayed on LCD1 in the work mode. The indication on LCD1 is cleared with pressing the switch.

Note: If the above message appears on the LCD1, contact your Link-Belt Distributor for a replacement battery. If the above message is displayed, replace the battery within a few days.

Operator's Manual

Functions To Be Adjusted With The Crane Set-up Mode

The following table shows the function, purpose, and time for adjustments using the crane set-up mode

Function			Purpose	When
Angle/Radius Adjustment	For crane attachment	Boom angle indicator Adjustment	This corrects an error detected in the boom angle/radius indicator.	Adjust when the working radius is out of the specified error range.
				Adjust when replacing the boom angle indicator.
Self-weight Adjustment			This corrects an error detected by the load cell (tension) due to the attachment self-weight.	Adjust when the working radius is out of the specified error range.
Setting of the self-weight corrected value			This sets the correct value in the computer memory related to the self-weight adjustment.	Set before adjusting the self-weight with the same attachment make-up.
Confirmation of the upper limit stop functioning	Upper limit stop by the limit switch		This confirms that the upper limit stop switch and the backstop limit switches are functioning properly.	Confirm before lifting any loads.
	Upper limit stop by LMI		This confirms that the upper limit stop of the upper limit and offset angle limit by LMI.	
Others			For Service Use Only	

Operator's Manual

Boom Radius/Angle Adjustment

Perform this adjustment when there is a boom angle or radius error reading in the computer display or when installing the boom base section or replacing the angle sensor. Adjust after inputting the attachment make-up information with the crane set-up mode (configuration mode).

Boom Angle Adjustment

1. Park the crane on a firm, level surface. Use the bubble level in the operator's cab to assist in leveling the crane.
2. Position the boom horizontal and verify 0 degree angle by using an inclinometer.
3. Loosen the locknuts on the angle sensor mounting bracket. Adjust bracket until 0 degree boom angle is displayed in LCD5. Tighten locknut. Refer to Figure 1-63.

Boom Radius Adjustment

4. With the control levers in "Neutral" and from the normal working screen press the SETTING START/END button. "CONFIGURATION" will now be displayed in LCD1. The Crane Setup Mode Indicator and Configuration Mode Indicator lights will illuminate.

Note: The crane set-up mode cannot be started if the control levers are not placed in the "Neutral" position. If the levers are not in the "Neutral" position, "Set Lever in Neutral" is displayed in LCD1.

5. Press the ENTER button when "ADJUSTMENT" is displayed in LCD1 to start the adjustment routine.

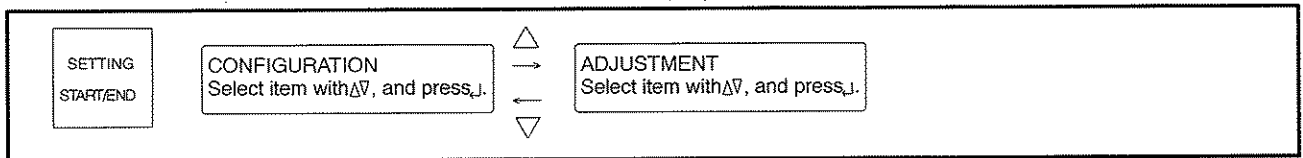

6. LCD1 will now prompt the adjustment items. Press the UP/DOWN buttons to scroll through the adjustment items.
7. When Angle Adjustment appears, press the ENTER button to select that item. The Adjustment Mode Indicator light will illuminate.

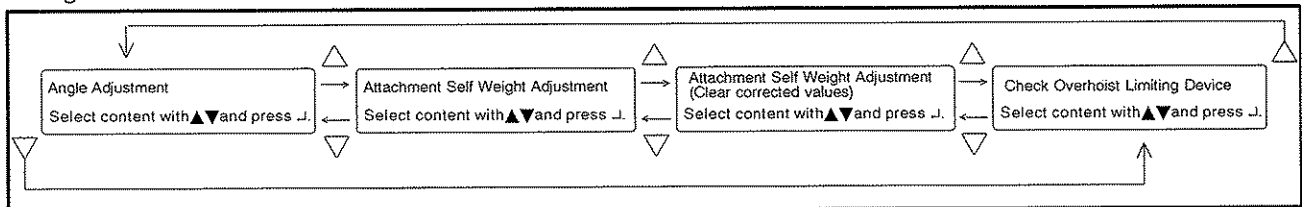

The following are displayed on each LCD;

LCD2: Drift correction value

LCD3: Gain correction value

LCD4: Working radius

LCD5: Boom angle

Each indicator light illuminates as shown below.

Attachment make-up	Without jib	With tip ex. boom or jib	Boom head with two hooks
Boom Indicator	◆	◆	◆
Jib Indicator		◆	
Working Radius Indicator	◆	◆	◆
Boom Hook Indicator	The lamp corresponded to the hook selected with the hook select switch is on.		
Jib Hook Indicator			

8. Select the hook with the hook select button that the working radius is to be measured. Press the enter switch.

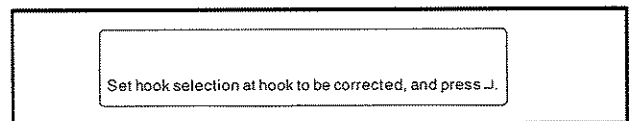

Operator's Manual

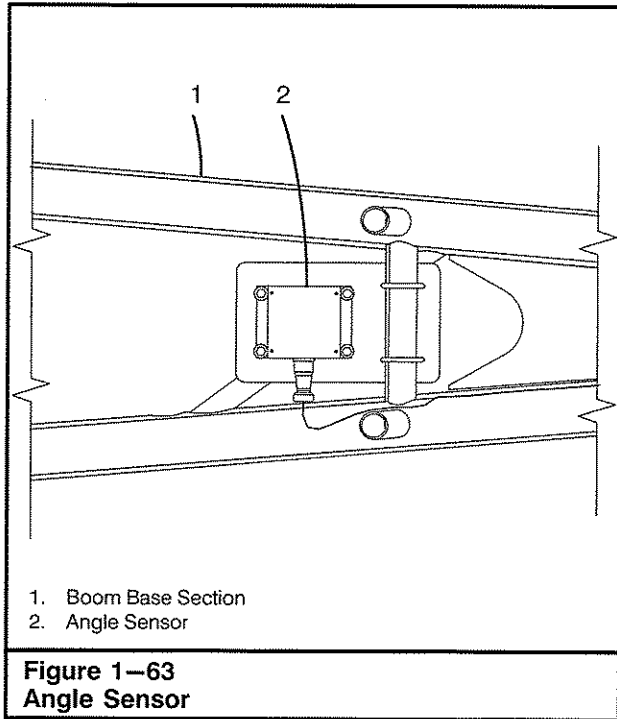

9. Set the boom angle to $60 \pm 0.1^\circ$ in LCD5 by raising or lowering the boom. Press the Enter button.

Set boom angle at 60° , and press \downarrow .

10. Measure the actual working radius and press the Enter button.

11. Input the measured working radius in LCD1 by pressing the scroll Up/Down buttons. Press the enter switch.

Set measured radius with \blacktriangle / \blacktriangledown , and press \downarrow .
53.5 ft

12. After calculation is complete, raise the boom until the boom is stopped automatically (boom angle upper limit). Press the Enter button.

Hoist up boom till it stops automatically, and press \downarrow .

13. Measure the actual working radius.

14. Input the measured working radius in LCD1 by pressing the scroll Up/Down buttons. Press the enter switch.

Set measured radius with \blacktriangle / \blacktriangledown , and press \downarrow .
20.4 ft

15. After calculation is complete, the drift correction value in LCD2 and gain correction value in LCD3 are updated.

16. When "Adjustment completed" is displayed, press the Enter button.

Adjustment completed, press \downarrow .

17. LCD1 will now display "Angle adjustment". Press the Setting Start/End button to complete the angle adjustment.

Operator's Manual

Self-weight Adjustment

This corrects an error in the load cell tension due to the change in the attachment self-weight. Adjust when the working radius is found to be incorrect. Adjust after inputting the attachment make-up information with the crane set-up mode (configuration mode).

1. With the control levers in "Neutral" and from the normal working screen press the SETTING START/END button. "CONFIGURATION" will now be displayed in LCD1. The Crane Setup Mode Indicator and Configuration Mode Indicator lights will illuminate.

Note: The crane set-up mode cannot be started if the control levers are not placed in the "Neutral" position. If the levers are not in the "Neutral" position, "Set Lever in Neutral" is displayed in LCD1.

2. Press the ENTER button when "ADJUSTMENT" is displayed in LCD1 to start the adjustment routine.

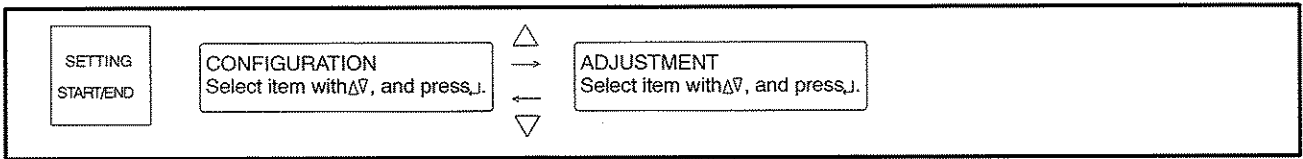

3. LCD1 will now prompt the adjustment items. Press the UP/DOWN buttons to scroll through the adjustment items.
4. When "Attachment self-weight adjustment" appears, press the ENTER button to select that item. The Adjustment Mode Indicator light will illuminate.

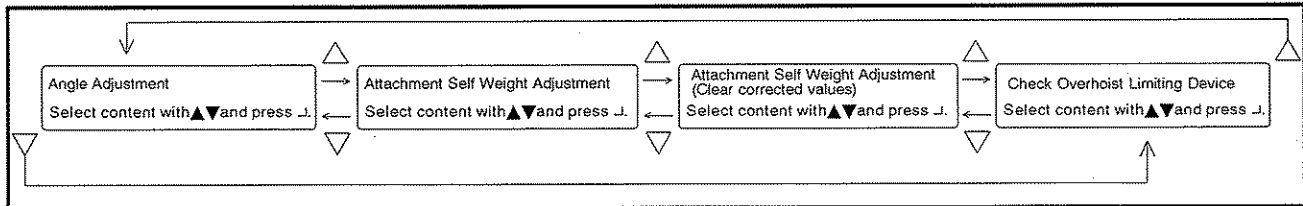

The following are displayed on each LCD;
 LCD2: Boom load cell self-weight correction value
 LCD3: Correction point No.
 LCD4: Working radius
 LCD5: Boom angle

Note: If the self-weight adjustment for the same attachment configuration is not performed, "HELP" in LCD2 is displayed.

Each indicator light illuminates as shown below.

Attachment make-up	Without jib	With tip ex. boom or jib	Boom head with two hooks
Boom Indicator	◆	◆	◆
Jib Indicator		◆	
Working Radius Indicator	◆	◆	◆
Boom Hook Indicator	The lamp corresponded to the hook selected with the hook select switch is on.		
Jib Hook Indicator			

5. Select the hook with the hook select button that the working radius is to be measured. Press the enter switch.

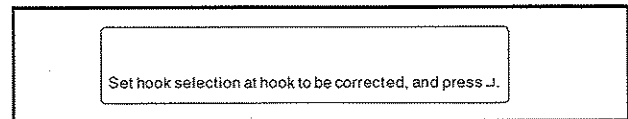

6. Raise the boom until the adjustment mode indicator light flashes and voice alarm "Auto Stop" sounds.

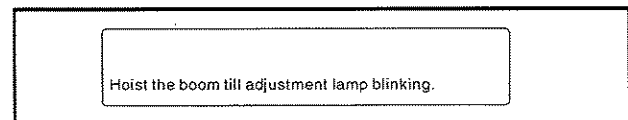

7. Place the boom hoist lever in the "Neutral" position. Press the Enter button.

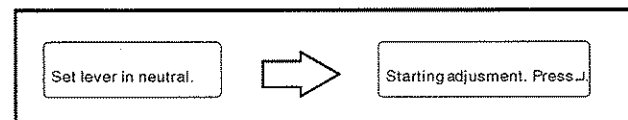

Operator's Manual

Table Of Contents

Crane Nomenclature	1-1
Operating Safety	1-2
General Safety Rules	1-2
Operator Awareness	1-2
Boom Safety Instructions	1-9
Electrical Dangers	1-13
Radio Frequency Or Electro Magnetic Interference (RFI Or EMI)	1-16
Protective Equipment	1-16
Signal Persons And Bystanders	1-16
Crane Inspections And Adjustments	1-17
Wire Rope	1-18
Crane And Area Clearance	1-19
Weights, Lengths, And Radii	1-20
Traveling	1-24
Leaving The Station	1-25
Personnel Handling Guidelines	1-26
Introduction	1-26
Authorization	1-26
Equipment	1-26
Maintenance, Lubrication, And Adjustments	1-27
Inspection And Rigging	1-27
Crane Test Procedures	1-28
Operation And Safety	1-29
Additional Requirements For Offshore Cranes	1-30
Fire Extinguisher	1-33
Operator's Cab	1-33
Overhead Control Panel	1-33
Load Moment Indicator Panel	1-34
Left Control Console	1-36
Right Control Console	1-38
Front Control Console	1-39
Air Conditioner Controls	1-41

Operator's Manual

8. Slowly lower the boom. Keep the hook block/hook ball approximately 3 ft (.9m) above the ground while lowering the boom.

The correction point has six places as shown below. The correction point Nos. (6 thru 1) are displayed on LCD3. When the boom approaches the correction point, the adjustment mode indicator light flashes. The light will illuminate after passing the correction point.

Lower the boom slowly during the adjustment mode so as not to stop abruptly when light flashes.

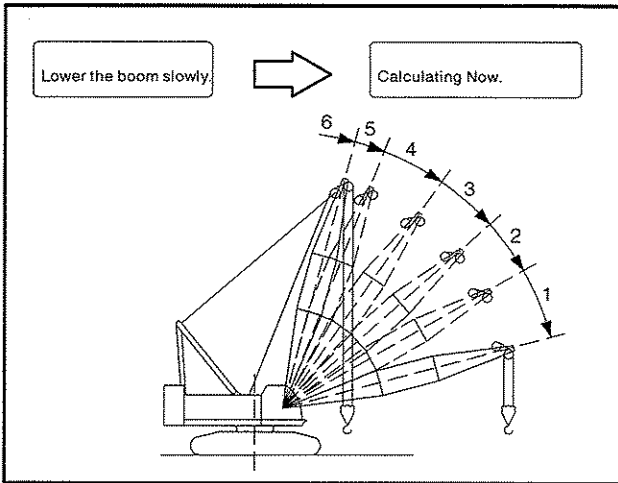

9. Place the boom hoist lever in the "Neutral" position when "Adjustment completed. Set the lever in neutral." in LCD1 is displayed, and press the Setting

Start/End button to complete the setting mode (adjustment).

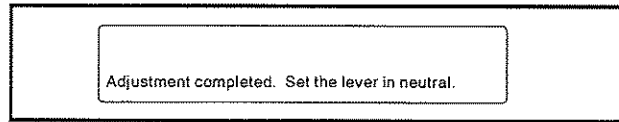

10. LCD1 will now display "Attachment Self-Weight Adjustment". Press the Setting Start/End button to complete the self-weight adjustment.

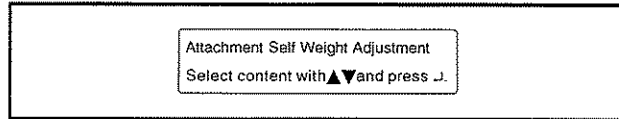

Remedy when placing the boom hoist lever in "Neutral" position in the middle of adjustment

When placing the boom hoist lever in "Neutral" position in the middle of adjustment (when the adjustment of correction point No. 6 to 1 is not completed), "Finish → ↵ Continue → Lower" in LCD1 is displayed. Proceed with the following procedures to complete the adjustment of the self-weight.

1. Proceed to Step 8 mentioned above and after this when continuing to correct.
2. When "Finish → ↵ Continue → Lower" in LCD1 is displayed, push the enter button. It returns to Initial indication of setting mode (adjustment).
3. Push the Setting Start/End button to complete the setting mode (adjustment).

Operator's Manual

Resetting Self-weight Corrected Value

This stores the new correction value in the computer memory after correcting the self-weight.

Reset before adjusting the self-weight with a same attachment make-up.

Correct after setting the attachment make-up information with the crane set-up mode (configuration mode).

1. With the control levers in "Neutral" and from the normal working screen press the SETTING START/END button. "CONFIGURATION" will now be displayed in LCD1. The Crane Setup Mode Indicator and Configuration Mode Indicator lights will illuminate.

Note: The crane set-up mode cannot be started if the control levers are not placed in the "Neutral" position. If the levers are not in the "Neutral" position, "Set Lever in Neutral" is displayed in LCD1.

2. Press the ENTER button when "ADJUSTMENT" is displayed in LCD1 to start the adjustment routine.

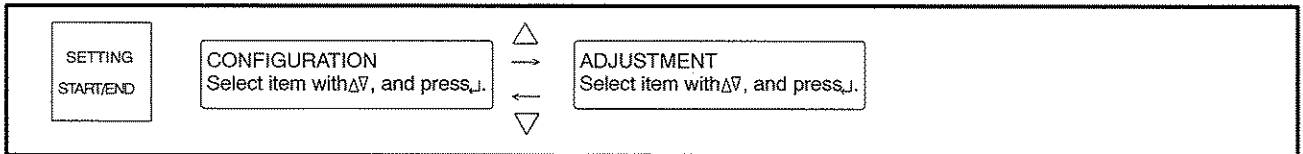

3. LCD1 will now prompt the adjustment items. Press the UP/DOWN buttons to scroll through the adjustment items.
4. When "Attachment self-weight adjustment (Clear corrected values)" appears, press the ENTER button to select that item. The Adjustment Mode Indicator light will illuminate.

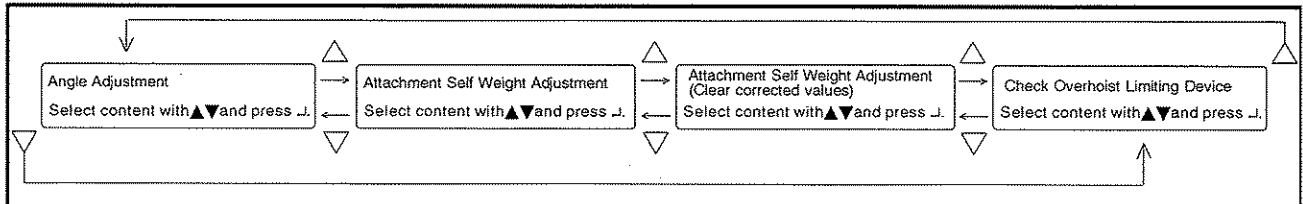

The following are displayed on each LCD;
 LCD2: Boom load cell self-weight correction value
 LCD3: Correction point No.
 LCD4: Working radius
 LCD5: Boom angle

Note: If the self-weight adjustment for the same attachment configuration is not performed, "HELP" in LCD2 is displayed.

Each indicator light illuminates as shown below.

Attachment make-up	Without jib	With tip ex. boom or jib	Boom head with two hooks
Boom Indicator	◆	◆	◆
Jib Indicator		◆	
Working Radius Indicator	◆	◆	◆
Boom Hook Indicator	The lamp corresponded to the hook selected with the hook select switch is on.		
Jib Hook Indicator			

5. When "Clear → ∟" is displayed in LCD1, press the ENTER button.

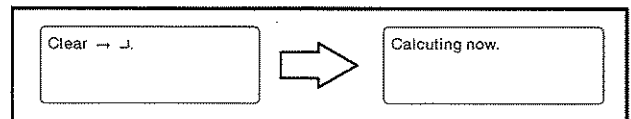

6. Press the ENTER button when "Clearing completed" is displayed.

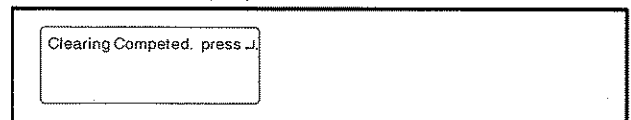

7. Press the SETTING START/END button. This completes the crane setup mode (adjustment).
8. The display returns to Initial indication of setting mode (adjustment).

Operator's Manual

Boom Hoist Limit Stop And Boom Backstop Limit Stop Confirmation

The boom hoist limit stop and the backstop limit stop can be activated by the limit switches and the Load Moment Indicator. The boom hoist function must stop automatically at the appropriate angle. Use the following procedures to confirm that the automatic stop functions properly before performing lift crane operations. The proper crane configuration must be input before performing confirmation procedure.

Boom Hoist Limit Stop from the Limit Switch

1. With the control levers in "Neutral" and from the normal working screen press the SETTING START/END button. "CONFIGURATION" will now be displayed in LCD1. The Crane Setup Mode Indicator and Configuration Mode Indicator lights will illuminate.

Note: The crane set-up mode cannot be started if the control levers are not placed in the "Neutral" position. If the levers are not in the "Neutral" position, "Set Lever in Neutral" is displayed in LCD1.

2. Press the ENTER button when "ADJUSTMENT" is displayed in LCD1 to start the adjustment routine.

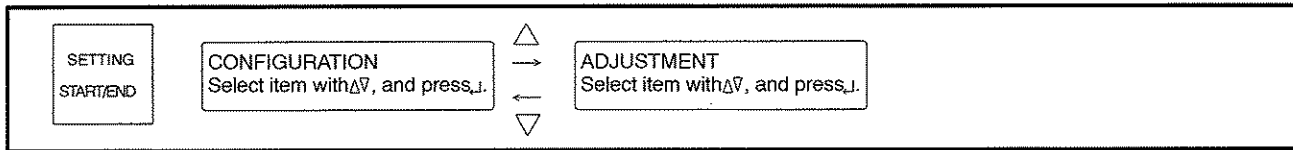

3. LCD1 will now prompt the adjustment items. Press the UP/DOWN buttons to scroll through the adjustment items.
4. When "Check Overhoist Limiting Device" appears, press the ENTER button to select that item. The Adjustment Mode Indicator light will illuminate.

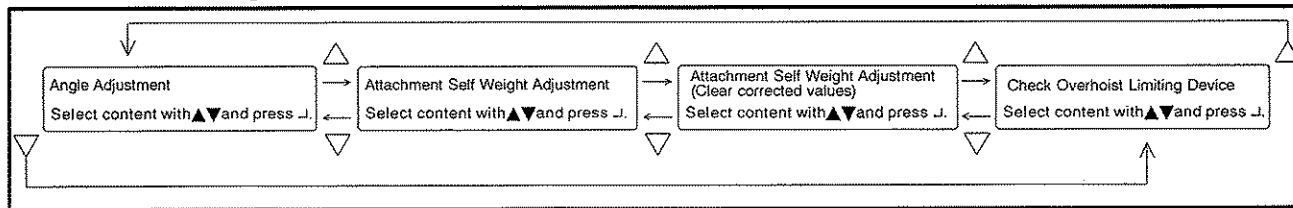

5. Press the UP/DOWN buttons to toggle between L/S (Limit Switch) and LMI (Load Moment Indicator). Item selected will be blinking. When "L/S" is blinking press the ENTER button.

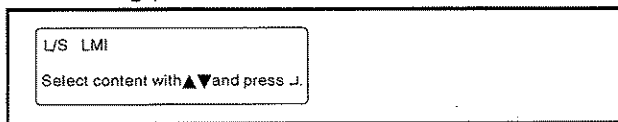

6. Raise the boom until the boom hoist limit switch activates (approximately 82°).
7. Confirm that: 1) boom hoist function has stopped, 2) voice alarm "Boom Hoist Limit" sounds, and 3) angle limit indicator light illuminates.
8. If the boom hoist limit switch does not activate at 82°, discontinue procedure and adjust limit switch. Refer to "Boom Hoist Limit Switch Adjustment" in Section 4 of this Operator's Manual.
9. Place the boom hoist lever in neutral.
10. After boom hoist limit switch confirmation, proceed to backstop limit switch confirmation.

Boom Backstop Limit Stop

11. Place the Master Control Override Switch in the "Enable" position.

12. Hold the Boom Hoist Override switch in the "Override" position and boom up until the backstop limit switch activates (approximately 84°). Release the Boom Hoist Override switch to the "Normal" position.
13. Confirm that: 1) all crane functions have stopped (except swing and travel, 2) voice alarm "Backstop Limit" sounds, and 3) angle limit indicator light illuminates.
14. Hold the Boom Backstop Override switch in the "Override" position and boom down until the backstop limit switch deactivates. Release the Boom Backstop Override switch to the "Normal" position.
15. If both limit switches activated at the proper angle, press the ENTER button to complete confirmation.

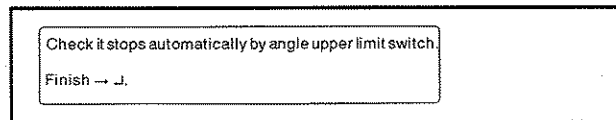

16. Press the SETTING START/END button. This completes the crane setup mode (adjustment).
17. The display returns to Initial indication of setting mode (adjustment).

Operator's Manual

Boom Hoist Limit Stop from the Load Moment Indicator

1. With the control levers in "Neutral" and from the normal working screen press the SETTING START/END button. "CONFIGURATION" will now be displayed in LCD1. The Crane Setup Mode Indicator and Configuration Mode Indicator lights will illuminate.

Note: The crane set-up mode cannot be started if the control levers are not placed in the "Neutral" position. If the levers are not in the "Neutral" position, "Set Lever in Neutral" is displayed in LCD1.

2. Press the ENTER button when "ADJUSTMENT" is displayed in LCD1 to start the adjustment routine.

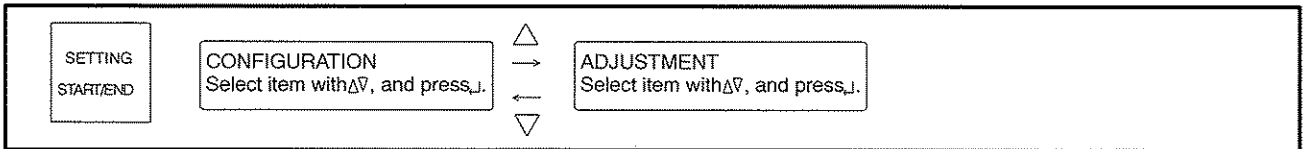

3. LCD1 will now prompt the adjustment items. Press the UP/DOWN buttons to scroll through the adjustment items.
4. When "Check Overhoist Limiting Device" appears, press the ENTER button to select that item. The Adjustment Mode Indicator light will illuminate.

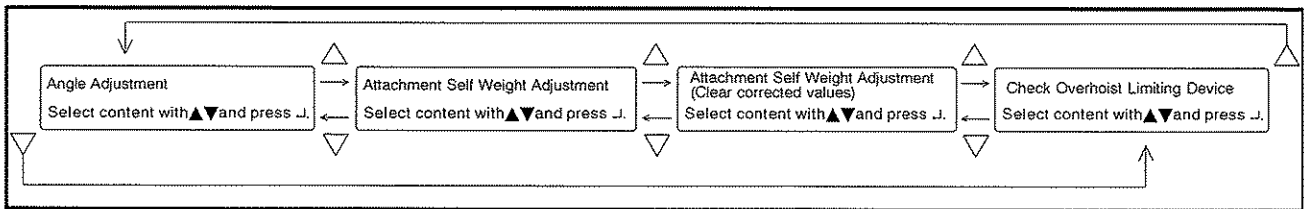

5. Press the UP/DOWN buttons to toggle between L/S (Limit Switch) and LMI (Load Moment Indicator). Item selected will be blinking. When "LMI" is blinking press the ENTER button.

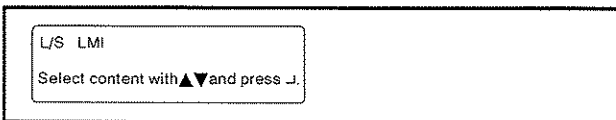

6. Raise the boom until the boom hoist upper limit stop activates by the LMI (approximately 77°).
7. Confirm that: 1) boom hoist function has stopped, 2) voice alarm "Boom Hoist Limit" sounds, and 3) angle limit indicator light illuminates.

8. Place the boom hoist lever in neutral.
9. Lower the boom until the upper limit stop is released.
10. Place the boom hoist lever in neutral.
11. Press the ENTER button to complete confirmation.

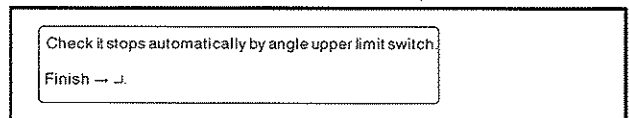

12. Press the SETTING START/END button. This completes the crane setup mode (adjustment).
13. The display returns to Initial indication of setting mode (adjustment).

Operator's Manual

Boom Angles for Activating Boom Upper Limit Stop				
Specification	Equipment	Upper limit stop functioning item		Angle
Crane	Limit Switch	A	Boom hoist limit switch	82°
		B	Slow down activates, "Approaching Limit" voice alarm is sounded ("A" minus 3 degrees)	79°
		C	Boom backstop limit switch activates	84°
	LMI	D	Slow down activates, "Approaching Limit" voice alarm is sounded ("A" minus 5 degrees)	77°
		E	Boom angle upper limit stop activates ("A" minus 2 degrees)	80°

Operator's Manual

Automatic Limiting Function Charts

This crane is equipped with automatic limiting functions controlled by limit switches, the safety controller, and the Load Moment Indicator. The following charts illustrate crane conditions when a limiting device has been activated.

Automatic Stop in Normal Work Mode															
Item		Detecting Portion (Applicable: ⊙)		○:Operation Possible Δ :Operation Impossible (Override Operation Possible) × :Operation Impossible (Override Operation Possible)						Indicator Lamp	Voice Alarm	Display	Effective Override Switch	External Light Bar	
Name of Automatic Stop	Detailed Function	Limit Switch Pressure Switch	LMI	Boom Raising	Boom Lowering	Hook Hoisting	Hook Lowering	Swing	Travel						
Boom Angle Limit	Boom Angle Max Upper Limit	⊙ Boom Back-stop		×	Δ	×	Δ	Δ	Δ	Angle Limit		Boom Hoist Limit		Back-stop	
	Boom Angle Upper Limit	⊙ Crane Boom Hoist Upper Limit	⊙	Δ	○	○	○	○	○			Boom Hoist Limit		Boom Hoist Limit	
	Boom Angle Lower Limit		⊙	○	Δ	○	○	○	○			Boom Hoist Limit		Boom Lower Limit	
Anti-Two Block	Hook Upper Limit	⊙ Hook Over-hoisting		○	Δ	Δ	○	○	○	Two Block	Two Block Limit		Anti-Two Block		

Operator's Manual

Automatic Stop in LMI Override												
Item			Detecting Portion (Applicable: ⊙)		⊙: Operation Possible Δ: Operation Impossible (Override Operation Possible) ×: Operation Impossible (Override Operation Possible)				Voice Alarm	Effective Override Switch	External Light Bar	
Mode	Name of Automatic Stop	Detailed Function	Limit Switch Pressure Switch	LMI	Boom Raising	Boom Lowering	Hook Hoisting	Hook Lowering				
LMI Override	Boom Angle Limit	Boom Angle Max Upper Limit	⊙ Boom Backstop		×	Δ	×	Δ	Boom Hoist Limit	Backstop		
		Boom Angle Upper Limit	⊙ Boom Hoist Upper Limit	⊙	Δ	○	○	○	Boom Hoist Limit	Boom Hoist Limit		
		Boom Angle Lower Limit		⊙	○	Δ	○	○	Boom Hoist Limit	Boom Lower Limit		
	Anti-two Block	Hook Upper Limit	⊙ Hook Overhoisting		○	Δ	Δ	○	Two Block Limit	Anti-Two Block		
	Overload	Load Ratio Limit		⊙	○	○	○	○	Overload Limit		Red/Yellow	
		Hook Wire Rope Line Pull Limit		⊙	○	○	○	○	Overload Limit			
		Working Radius Limit		⊙	○	○	○	○	Overload Limit			
	Low Control Pressure		⊙ Hydraulic Control Pressure Detecting			×	×	×	×	Hydraulic Control Pressure Reduced	Backstop	

Operator's Manual

Automatic Stop in Rigging Mode																
Item	Detecting Portion (Applicable: ☉)	Operation Possible										Indicator Lamp	Voice Alarm	Display	Effective Override Switch	External Light Bar
		Δ: Operation Impossible (Override Operation Possible)	x: Operation Impossible (Override Operation Possible)	Δ: Operation Impossible (Override Operation Possible)	x: Operation Impossible (Override Operation Possible)	Δ: Operation Impossible (Override Operation Possible)	x: Operation Impossible (Override Operation Possible)	Δ: Operation Impossible (Override Operation Possible)	x: Operation Impossible (Override Operation Possible)	Δ: Operation Impossible (Override Operation Possible)	x: Operation Impossible (Override Operation Possible)					
Mode	Crane Status	Limit Switch Presure Switch	RCL	Boom Raising	Boom Lowering	Jib Raising	Jib Lowering	Hook Hoisting	Hook Lowering	Swing	Travel	Overload Angle Limit (Blinking)	Rigging Mode	LOD1: (Upper Column) Rigging Mode (Lower Column) Set Curve Selection correctly	Jib Lower Limit	Red
Crane Set-Up	Hook Overhoisting	Hydraulic Control Presure Detecting	☉	○	○	-	-	Δ	○	○	○	Two Block	Boom Protection Activated	LCD3: Help Blinks	Ant-Two Block	Red

Operator's Manual

6. Pull back on the hand throttle slightly and move the Engine Starter Key Switch clockwise to first position.

Note: All of the indicator lights of the service monitor are tested when the Engine Starter Key Switch is moved from the "OFF" to the "ACC" position. If these lights do not illuminate when tested, find and repair the problem before continuing operations.

7. Turn the Engine Starter Key Switch to the "Start" position. Release the switch immediately after the engine starts. If the engine fails to start in 30 seconds, release the switch and allow the starter motor to cool a few minutes before trying to start the engine again. If the engine fails to start after four attempts, refer to the engine manufacturer's manual for instructions.
8. Warm Up – Run the engine at low throttle with no load while engine is warming up. Observe the following instruments for proper indications:
 - a. Service Monitor – Individual indicator lights are contained in this gauge. The appropriate indicator will illuminate for any one of the following conditions: Engine oil filter is being bypassed, Low engine oil pressure, Low engine coolant level, Swing (park) brake applied, Low battery electrolyte level, Low charging voltage at battery, or Restricted air flow at engine air cleaner.
 - b. Hydraulic Oil Temperature Gauge – In cold weather, do not operate the crane with a load until the hydraulic oil temperature registers in the green area of the gauge.
9. When the engine has thoroughly warmed up, all pressures and temperatures are within operating ranges, and all daily checks have been made, the crane is ready for operation.

Engine Shutdown

Engine Shutdown Procedure

1. Lower load to the ground and secure it properly.
2. Check that the gate lock lever is in the "Stop" position and all control levers are in the neutral position to prevent inadvertent operation of the crane.
3. Check that the travel swing lock is engaged and the swing (park) brake switch, on the top of the swing control lever, is in the "ON" position.
4. Confirm that both drum brake pedals are latched in the fully applied position and all drum lock switches are "ON".
5. Throttle the engine back to idle.

6. Turn the Engine Starter Key Switch to the "OFF" position.
7. Remove the keys from operator's cab and lock the door if the crane is to be left unattended.

Break-In Period

Operate a new crane at half throttle for the first twenty (20) hours of operation. A break-in period under moderate loads will assist in providing long, troublefree performance.

General Operation

The following contains helpful information for typical lift crane operation. This information is general in nature and is not intended to serve as a fail safe procedure for any situation. The operator must, at all times, be alert and fully aware of the load requirements and specific job site conditions. He must be ready and able to perform any change in procedure, in a moments notice, to safely operate the crane as the immediate situation changes.

Lift Crane Operation

Cranes are used primarily for making heavy lifts. In order to do this properly, certain procedures must be followed. The following is a suggested procedure for making typical lifts:

1. Determine the weight to be lifted. Remember to add the weight of the hook block, hook ball, slings, rigging, jib, etc. Determine height to which the load must be lifted.
2. Refer to the Working Areas, Working Range, and the appropriate capacity charts in the Crane Rating Manual. Find the shortest boom length and load radius that will accomplish the job and assemble the crane accordingly.
3. Position crane so a minimum swing is necessary.
4. The crane must be supported by a firm, level surface before starting to lift. All capacities on the capacity charts in the Crane Rating Manual are based on the crane being level in all directions. If the crane is not level, out swing or side swing of the load will greatly reduce lifting capacities and could cause crane damage or an accident. If the ground is soft, use mats.
5. Check that the proper counterweight arrangement is properly installed. Do not make lifts which exceed capacity chart ratings in the Crane Rating Manual.
6. Check that the correct configuration has been input in the Load Moment Indicator (LMI).
7. Raise the boom to the desired height and swing over the load.

Operator's Manual

8. Lower the hook block/hook ball and fasten it to the load. The following points must be observed:
 - a. The boom peak must be directly above the load. Booms are made to lift and should not be used to drag a load sideways.
 - b. Always use chains, wire ropes, or slings of ample size and make periodic checks of their condition.
 - c. Always use sufficient parts of line. Refer to the Wire Rope Capacity Chart in the Crane Rating Manual for the number of parts of line needed for a given lift.
 - d. When lifting loads, care should be taken to prevent sudden loading or unloading of the winch wire rope. Ease into the load. Lift the load a few inches (*cm*) off the ground and hold to check the brakes.
9. Lift the load to the desired height. Use care when booming down or swinging the load, as these increase the load radius and result in a decrease in capacity. Ensure the load being lifted remains within the lifting capacity of the crane for the boom length, radius, and working area being used.
10. Control the load at all times. Use hand lines to guide the load. Do not guide loads into place with your hands. Swing slowly and smoothly. Avoid jerks when starting or stopping swings.

Duty Cycle Applications

Link-Belt requires the use of an accurate load indicating system with an anti-two block system for all lift crane operation. Some cranes are used for both lift crane and duty cycle operations. While operating in duty cycle operations, the load indicating equipment (load cells, pressure switches, etc.) is subjected to damage due to shock loads. These shock loads also cause the Load Indicating System Display to fluctuate rapidly making it difficult to read. Duty cycle operations normally involve repeated lift or digging cycles where the load on the crane is approximately the same during each cycle, and is known by the crane operator. This load is a known load due to the fact that the bucket, magnet, drop ball, etc. is selected and approved for the specific crane in use.

As a result of the above factors, Link-Belt will allow a crane to be operated in these duty cycle type applications with the Load Indicating System in the bypass or

override mode. If necessary to prevent damage to load cells and other components in the Load Indicating System, these items may be removed from the crane during duty cycle operation.



WARNING

All crane applications, including duty cycle applications, require that the total load being lifted be within the allowable capacities listed in the Crane Rating Manual. Anytime the load exceeds the capacities in the Crane Rating Manual, the crane is being overloaded. Overloading may cause major crane damage and can lead to serious personal injury.

After completing duty cycle operations and returning to lift crane operations, the Load Indicating System must be installed and returned to its normal working condition with all sensors connected and working accurately. Inspection, calibration, and verification of the system must be performed before starting lift crane operations.

Dragline Operation

With the bucket lowered in digging position pull the front drum control to pull the bucket toward the crane. Regulate the depth of cut by dragging the rear drum brake or hoisting the rear drum. As the bucket fills, release the front drum control and apply both brakes to hold the bucket and keep it from unloading.

Begin hoisting the loaded bucket by engaging the rear drum control and simultaneously releasing both the front and rear drum brake pedals. However, a slight drag on the front drum brake is required to balance the bucket. Once the bucket is to the desired height, fully apply both drum brakes.

Swing to the desired location and gradually check swing to slow and then stop rotation of the upper. Dump the load by releasing the front drum brake.

Swing the upper back to the digging spot by actuating the swing control. Spot the swing at the desired location by gradually checking the swing to slow and then stop rotation of the upper. Lower the bucket to the ground by gradually releasing both drum brakes.

Operator's Manual

Crane System Controls	1-42
Engine Throttle Controls	1-42
Pump Control System	1-42
Boom Hoist Operation	1-42
Boom Hoist Limit System	1-44
Boom Backstop Limit	1-44
Boom Lower Limit	1-44
Boom Angle Indicator	1-45
Front And Rear Drum Operation	1-45
Operating In "AUTO BRAKE" Mode	1-45
Operating In "FREE" Mode	1-46
Third/Fourth Drum Control	1-47
Drum Rotation Indicator	1-47
Upper Horn	1-47
Swing Operation	1-47
Swing (Park) Brake	1-47
Travel Swing Lock	1-48
To Swing The Upper	1-48
Steering And Traveling The Crane	1-49
Operating In Wind Or Lightning	1-50
Crane Monitoring System	1-51
Anti-Two Block System	1-51
Load Moment Indicator	1-52
System Description	1-53
Display Unit	1-53
System Operation	1-58
System Inoperative Or Malfunctioning	1-58
Configuration Selection	1-59
Rigging Mode	1-64
Operator Settable Limits	1-65
Setting Tip Height Limit	1-65
Setting Radius Limit	1-66

Operator's Manual

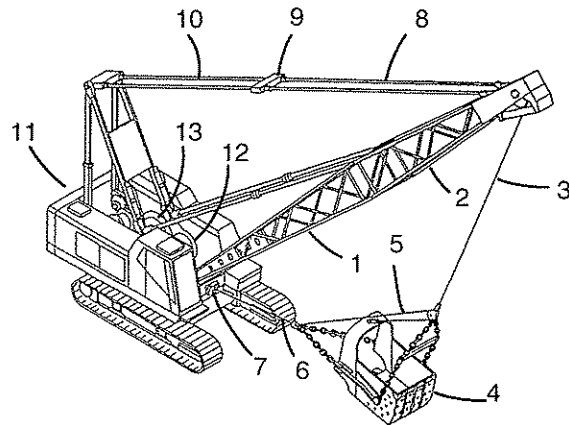

- | | | | |
|-----------------------|----------------------|--------------------------|-------------------|
| 1. Boom Base Section | 5. Dumping Wire Rope | 8. Pendants | 11. Counterweight |
| 2. Boom Top Section | 6. Inhaul Line | 9. Bridle | 12. Front Drum |
| 3. Hoisting Wire Rope | 7. Fairleader | 10. Boom Hoist Wire Rope | 13. Rear Drum |
| 4. Bucket | | | |

Figure 1-66
Typical Dragline Rigging

Operating Tips For Dragline Operation

1. Do not exceed the capacities in "Duty Cycle Capacities" in the Crane Rating Manual.
 2. Follow all recommendations for duty cycle capacities as stated in the Crane Rating Manual.
 3. Check that the correct configuration (curve) has been input in the Load Moment Indicator (LMI).
 4. Select the right size bucket for the size of crane and the type of material being excavated. Effective use of a dragline is dependent upon an efficient cycle of digging, hoisting, swinging, and dumping. The power of the crane to accomplish this, plus the weight of a loaded bucket, the proper laggings, and the length of boom must all be taken into account when determining bucket size.
 5. Keep the teeth sharp, and tightly mounted for efficient digging.
 6. Inspect the drag chains periodically, paying particular attention to the end links. You may be able to extend chain life by reversing it end for end or top to bottom.
 7. If bucket fails to dig properly, adjust chain connection.
 8. Keep the dump wire rope adjusted. When the wire rope is too long, the bucket must be pulled up close to the fairleader to keep it level. Too long a dump wire rope causes the bucket to dump before it gets out under the boom peak minimizing reach.
 9. Work with the boom at the highest angle that will allow the reach and accuracy needed for the job. A low boom (35° to 40°) gives a longer reach and better control of the bucket throw along with more accurate grading and dumping. A high boom (45° to 50°) increases stability and decreases swing loads and swing power requirements.
- Note: Dragline operation with boom angles of less than 35° is not recommended.**
10. Keep the crane close enough to the work to eliminate digging beyond the boom point as much as possible and reduce unnecessary casting and hoisting.
 11. Slice material off in layers. In ditch excavation, remove the sides or slopes before the center to keep the ditch from narrowing and to prevent using the swing system to hold the bucket against the banks.
 12. Use a short haul. Hoist the bucket when it is full. After the bucket is full, no more material may be loaded no matter how far it is pulled.

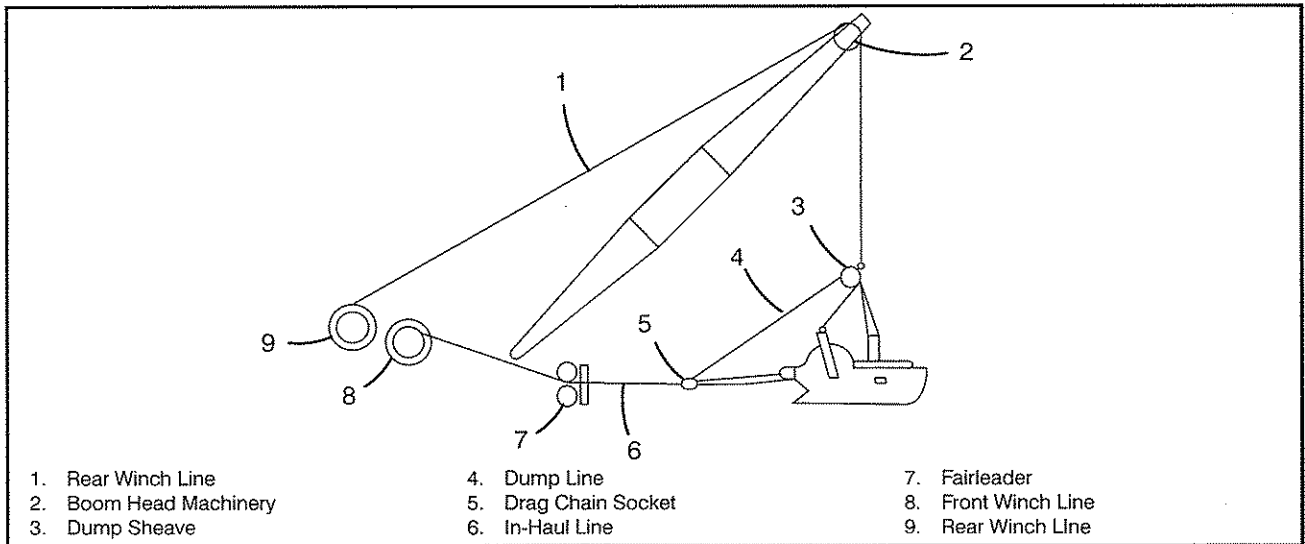

**Figure 1-67
Dragline Reeving Diagram**

13. Move back and dig off top edges that may wear or cut the drag wire rope. Avoid pilling dirt on your "doorstep". Piling dirt under the boom foot wastes time and power besides making a "wear trap" for the dragline.
14. Keep the bucket as far from the boom as possible without spilling the load. This will reduce wear and tear on wire ropes and clutches and will also minimize bucket and boom damage.
15. Don't pull the drag bail socket into the fairleader. Keep dirt and mud cleaned off the fairleader to prevent wear on drag wire rope and fairleader.
16. Don't drop the bucket to stop swing of the upper. Don't bang the bucket against banks or truck bodies to knock out sticky mud. Don't drop the bucket in a heap as the chains and wire ropes will become tangled.
17. Boom length for dragline work should not exceed 70 ft (21.3m).

Fairleader Assembly

When the crane is equipped with a dragline attachment, a fairleader is mounted on the front of the upper frame to guide the dragline inhaul wire rope onto the front drum. The fairleader is the full revolving type with the barrel, sheaves, and rollers mounted in anti-friction bearings.

The front winch only should be used as the in-haul line (dragline). Reeve the front winch drum as shown in Figure 1-67.

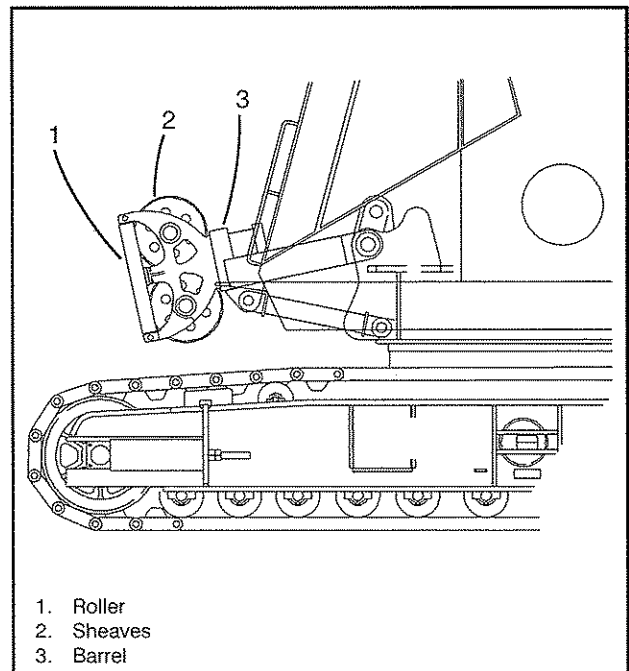

**Figure 1-68
Fairleader Assembly**

Operator's Manual

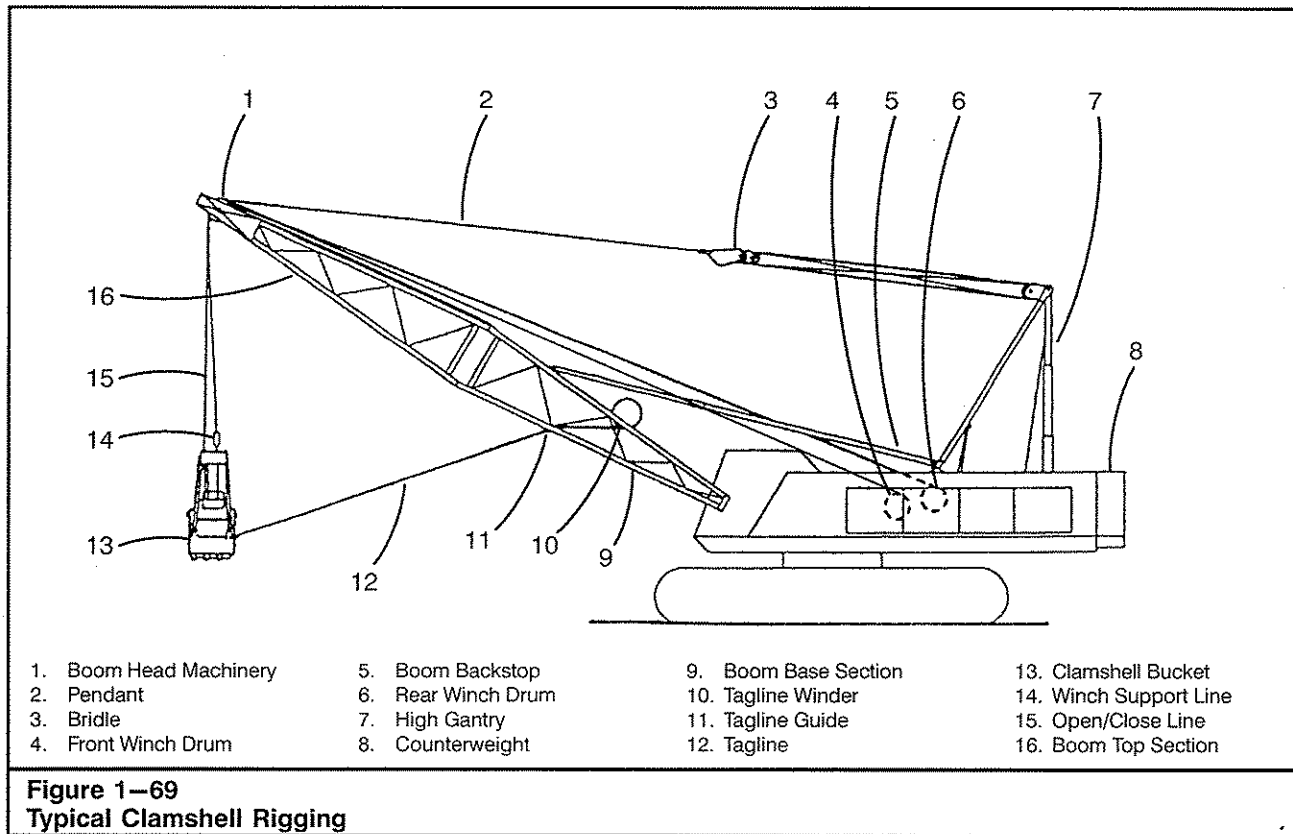

Clamshell Operation

The following procedure is written as though the open/close winch line is rigged to the rear drum. This line does not have to be on the rear drum. The front and rear drum winch lines may be rigged to satisfy the operator.

With the bucket in digging position, engage the rear drum control while simultaneously releasing the rear drum brake, to fill and close the bucket. As the bucket closes, engage the front drum control while simultaneously releasing the front drum brake to hoist the bucket. When the bucket reaches the desired height, fully apply both brakes and release both control levers.

Swing to the desired location and gradually check the swing to slow and then stop rotation of the upper. Dump the load by releasing the rear drum brake.

Swing the upper back to the digging spot by actuating the swing control. Spot the swing at the desired location by gradually checking the swing system to slow and then stop rotation of the upper. Lower the bucket to the ground by gradually releasing both drum brakes.

Operating Tips For Clamshell Operation

1. Do not exceed the capacities in "Duty Cycle Capacities" in the Crane Rating Manual.
2. Follow all recommendations for duty cycle capacities as stated in the Crane Rating Manual.
3. Check that the correct configuration (curve) has been input in the Load Moment Indicator (LMI).
4. Select the right size bucket for the size of crane and the type of material being excavated. Effective use of a clamshell is dependent upon an efficient cycle of digging, hoisting, swinging, and dumping. The power of the crane to accomplish this, plus the weight of a loaded bucket, the proper laggings, and the length of boom must all be taken into consideration when determining bucket size.
5. Lift the bucket as soon as it fills. Start to swing as the bucket is lifted to save time on the digging cycle.
6. Keep a tight closing line while hoisting. Do not release the closing line while the bucket is being raised or the bucket will open too soon.

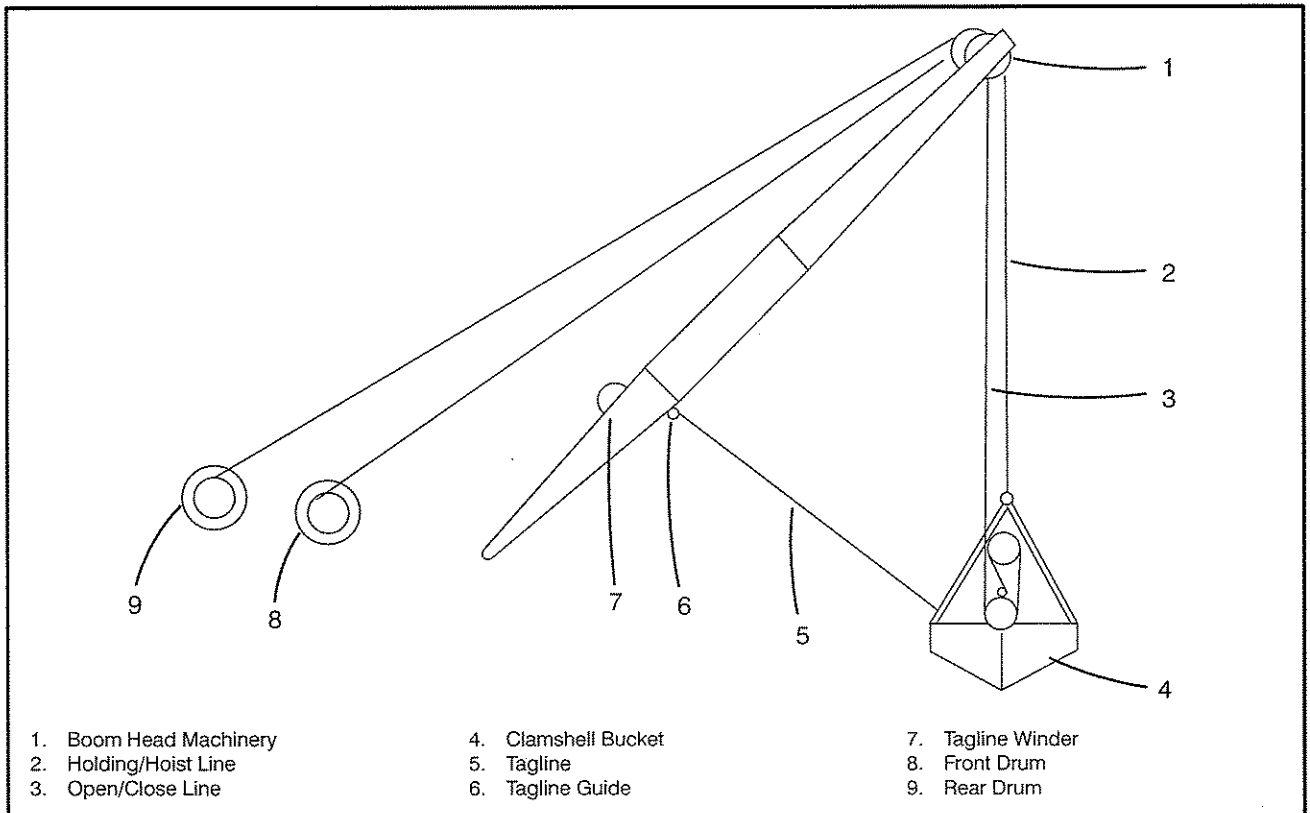

Figure 1-70
Clamshell Reeving Diagram

7. When returning to digging position with the bucket open, don't tighten up on the closing line or the bucket will close in mid air.
8. Match the lengths of closing and holding wire ropes. This is particularly necessary in deep digging which requires spooling of more than one wrap on the drums. With properly matched wire rope lengths, both the closing and holding lines will start the second wrap at the same time and provide smooth operation.
9. Attach the tagline to hold the bucket in line or crosswise to the boom, whichever will give best control of bucket placing and dumping for the job condition.
10. When lowering the bucket into deep trenches where it can't be seen, use a signal person to advise you of the bucket position. Lowering the bucket closed and opening it on signal is sometimes advisable because it affords greater clearance.
11. Each bucket manufacturer recommends the parts of line to reeve the bucket for digging various materials. In general, loose flowing materials require fewer parts of line for faster closing. For harder materials or digging, increase the number of parts of

- line. Add the recommended bucket counterweight for better bucket penetration and digging.
12. Don't bang the bucket to release sticky material. Close bucket and release closing line quickly to shake material loose.
13. Boom length for clamshell work should not exceed 70 ft (21.3m).

Tagline Winder

The tagline winder is installed on the boom base section. It utilizes torsional force of a spring to provide proper tension for the tagline wire rope which is wound on the drum. During clamshell operation, the tagline winder is used to stabilize the bucket and hold it in its working position, preventing the clamshell bucket from swinging and twisting during operation.

The front or rear winch line can be reeved to act as the opening/closing control line to satisfy the operator. Reeve the winch lines as shown in Figure 1-70.

Operator's Manual

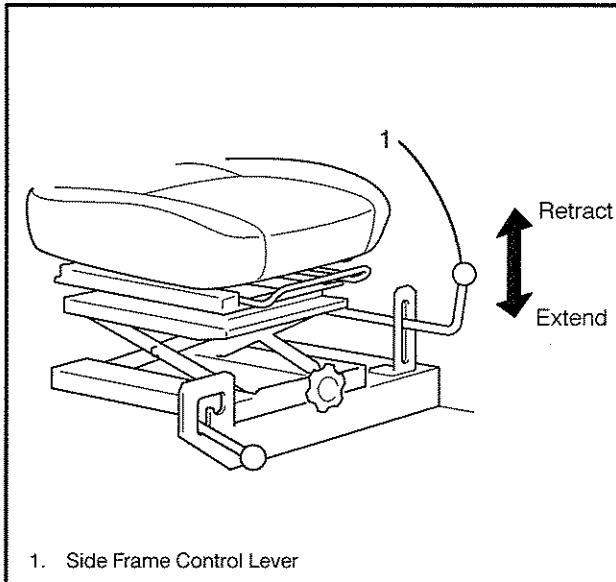

1. Side Frame Control Lever

Figure 1-71
Side Frame Control Lever

Crane Assembly And Disassembly

When transporting, the crane may require disassembly. When at the job site, it will require reassembly. The following instructions are recommended, safe procedures for assembling and disassembling the crane. Due to job site conditions and the availability of auxiliary equipment, other methods may be used only if they are proven, safe methods. If any questions exist about the safety of any procedure, contact your Link-Belt Distributor.

Crane Assembly

1. Extend the side frames. Refer to "Extending The Side Frames" in this Section of this Operator's Manual.
2. Install the counterweights. Refer to "Counterweight Installation And Removal" in this Section of this Operator's Manual.
3. Install the boom. Refer to "Boom Assembly and Disassembly" in Section 4 of this Operator's Manual.

Crane Disassembly

1. Remove the boom. Refer to "Boom Assembly and Disassembly" in Section 4 of this Operator's Manual.
2. Remove the counterweights. Refer to "Counterweight Installation And Removal" in this Section of this Operator's Manual.

3. Retract the side frames. Refer to "Retracting The Side Frames" in this Section of this Operator's Manual.

Extending And Retracting The Side Frames

The side frames are extended and retracted hydraulically. The control lever for extending/retracting the side frames is under and to the left of the operator's seat in the operator's cab. Refer to Figure 1-71.



WARNING

Extending and retracting the side frames must be done on firm, level ground.

Do not travel or swing the crane with the counterweight(s) installed and the side frames retracted. It may cause the crane to tip over resulting in serious personal injury and/or major crane damage. Place the upper parallel with the side frames and engage the travel swing lock and/or the swing (park) brake.

Extending The Side Frames

1. Park the crane on a firm, level surface and in an area suitable for extending side frames.
2. Position the boom over the end of the lower and engage the travel swing lock.
3. Remove all mud from the parts where the side frames will be extended.
4. Remove the top lock pin from the link pin. Remove link pin from the bottom of the retract link. Refer to Figure 1-72.

Note: It may be necessary to operate the extend/retract lever back and forth to free the pins.

5. Install the link pin into the top of the retract link.
6. Repeat Steps 4 and 5 for the other three retract links.
7. Extend the side frame cylinder until the link pin drops into the retract link. Install the lock pin in the bottom of the link pin.

Retracting The Side Frames

1. Park the crane on a firm, level surface and in an area suitable for retracting the side frames.
2. Position the boom over the end of the lower and engage the travel swing lock.
3. Remove all mud from the parts where the side frames will be retracted.

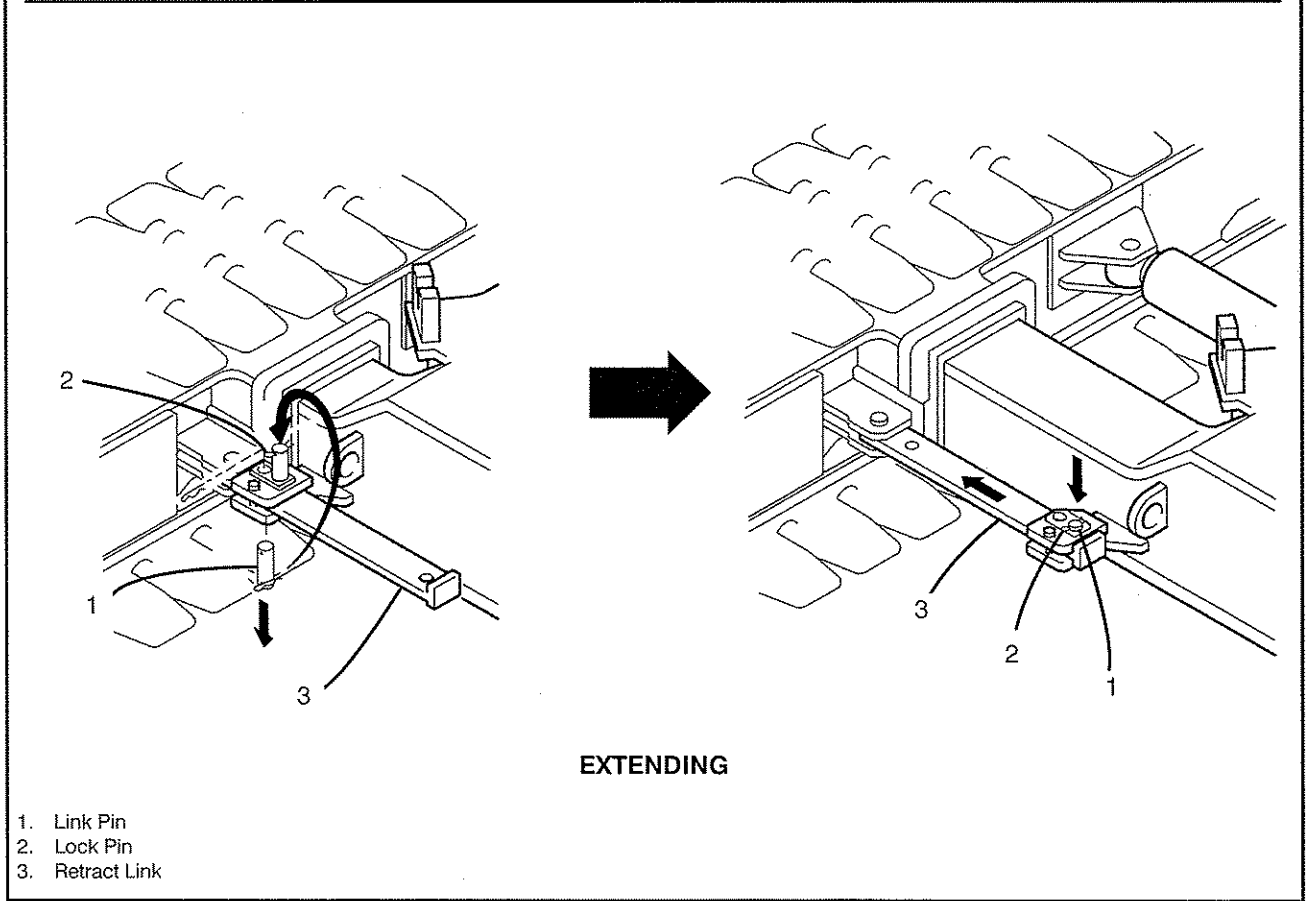
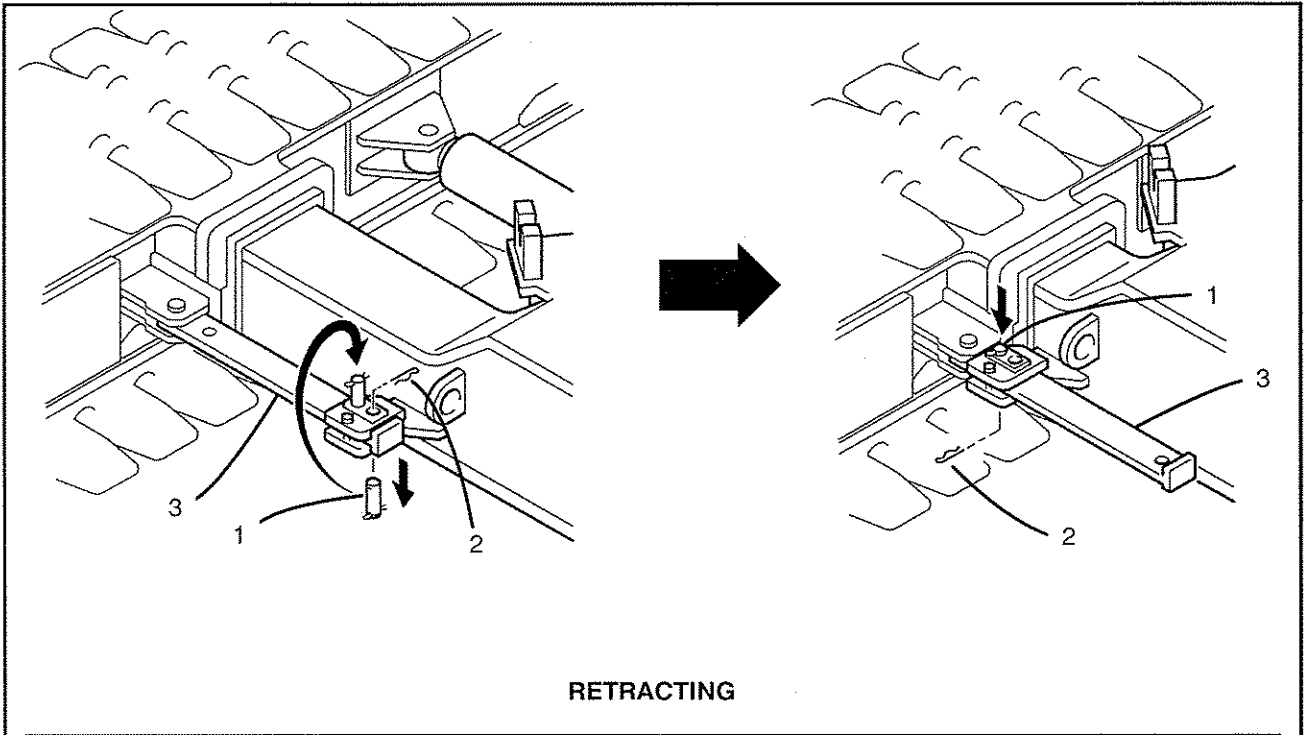

- 1. Link Pin
- 2. Lock Pin
- 3. Retract Link

Figure 1-72
Extending/Retracting The Side Frames

Operator's Manual

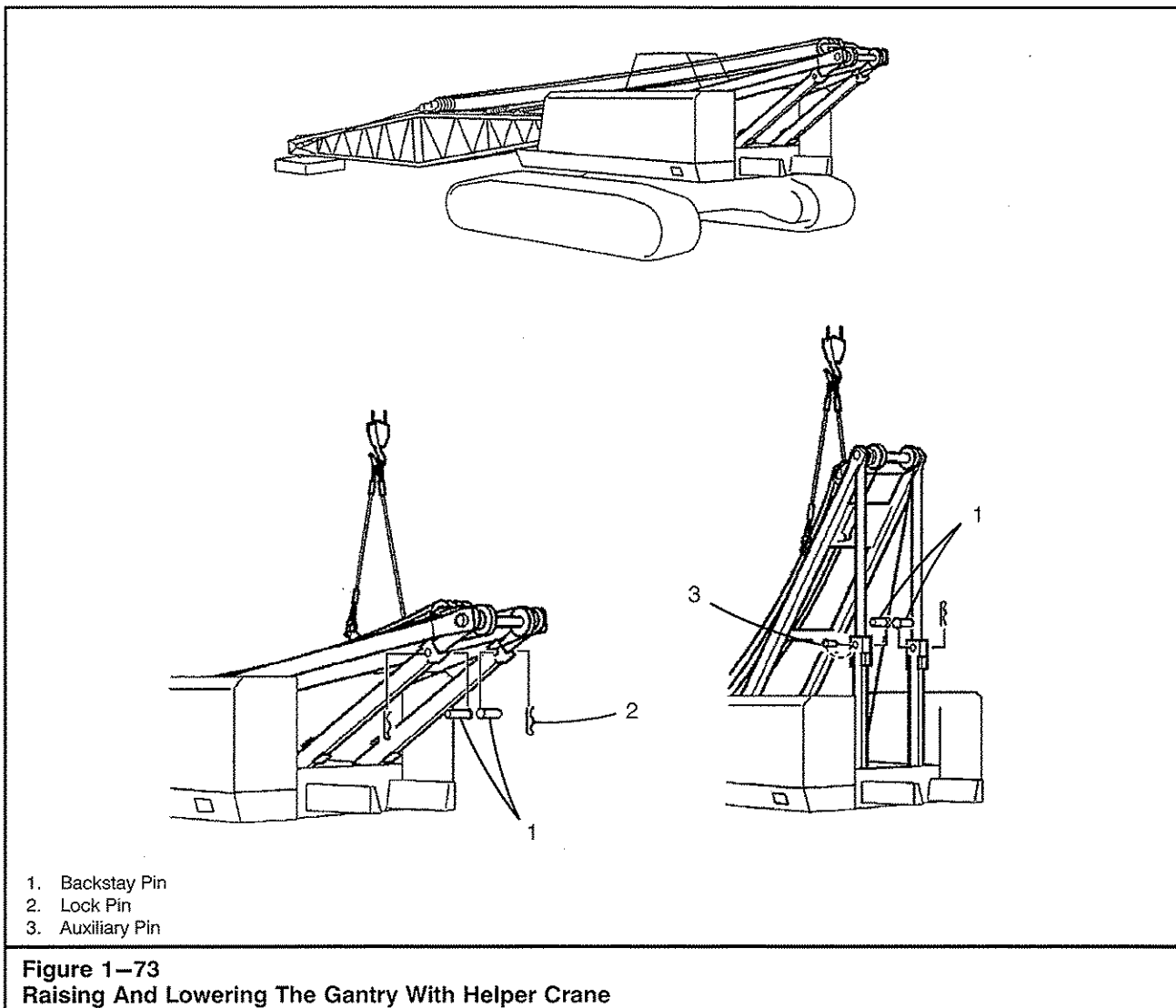

4. Remove the top lock pin from the link pin. Remove link pin from the bottom of the retract link. Refer to Figure 1-72.

Note: It may be necessary to operate the extend/retract lever back and forth to free the pins.

5. Install the link pin into the top of the retract link.
6. Repeat Steps 4 and 5 for the other three retract links.
7. Retract the side frame cylinder until the link pin drops into the retract link. Install the lock pin in the bottom of the link pin.

Raising And Lowering The Gantry

Raising and lowering the gantry can be performed using a helper crane or by using the boom hoist.

Raising The Gantry With Helper Crane

1. Place the crane on firm, level ground and position the upper parallel to the side frames. Engage the travel swing lock.
2. The side frames must be locked in the fully extended position. Refer to "Extending And Retracting The Side Frames" in this Section of this Operator's Manual.

CAUTION

Loosen the wire rope sufficiently so that the pins can be removed.

3. Lower the boom end onto blocking to remove the tension on the boom hoist wire rope.

Operator's Manual

4. With a sling attached to the gantry, use a helper crane to support the gantry, but do not lift it up.

CAUTION

The backstay pins must be removed before attempting to raise the gantry to the high position. Failure to remove the pins will cause damage.

5. Remove the left backstay pin and install auxiliary pin. Refer to Figure 1–73.
6. Remove the right backstay pin.

Note: When removing the auxiliary pin, confirm that it is loose. If the pin cannot be removed smoothly, check that the boom hoist wire rope is loosened properly. If necessary, move boom hoist lever back and forth to free the pins.

7. Remove the auxiliary pin from the left side and properly store on gantry.
8. Lift the gantry to high position.



WARNING

Insert backstay pins from the inside to the outside of the struts. Install the lock pins on the outside. Backstay pins must be installed to hold gantry in position for all lifting operation.

9. Install the right and left backstay pins and lock pins. Refer to Figure 1–73.

Lowering The Gantry With Helper Crane

1. Place the crane on firm, level ground and position the upper parallel to the side frames. Engage the travel swing lock.
2. The side frames must be locked in the fully extended position. Refer to "Extending And Retracting The Side Frames" in this Section of this Operator's Manual.

CAUTION

Loosen the wire rope sufficiently so that the boom will not be raised during gantry lowering procedure.

3. Lower the boom end onto blocking to remove the tension on the boom hoist wire rope.
4. With a sling attached to the gantry, use a helper crane to support the gantry, but do not lift it up.

CAUTION

The backstay pins must be removed before attempting to lower the gantry. Failure to remove the pins will cause damage to the backstops.

5. Remove the left backstay pin and install auxiliary pin. Refer to Figure 1–73.
6. Remove the right backstay pin.

Note: When removing the auxiliary pin, confirm that it is loose. If the pin cannot be removed smoothly, check that the boom hoist wire rope is loosened properly. If necessary, move boom hoist lever back and forth to free the pins.

7. Remove the auxiliary pin from the left side and properly store on gantry.
8. Lower the gantry to low position.



WARNING

Insert backstay pins from the inside to the outside of the struts. Install the lock pins on the outside. Backstay pins must be installed to hold gantry in position for all lifting operation.

9. Install the right and left backstay pins and lock pins. Refer to Figure 1–73.

Operator's Manual

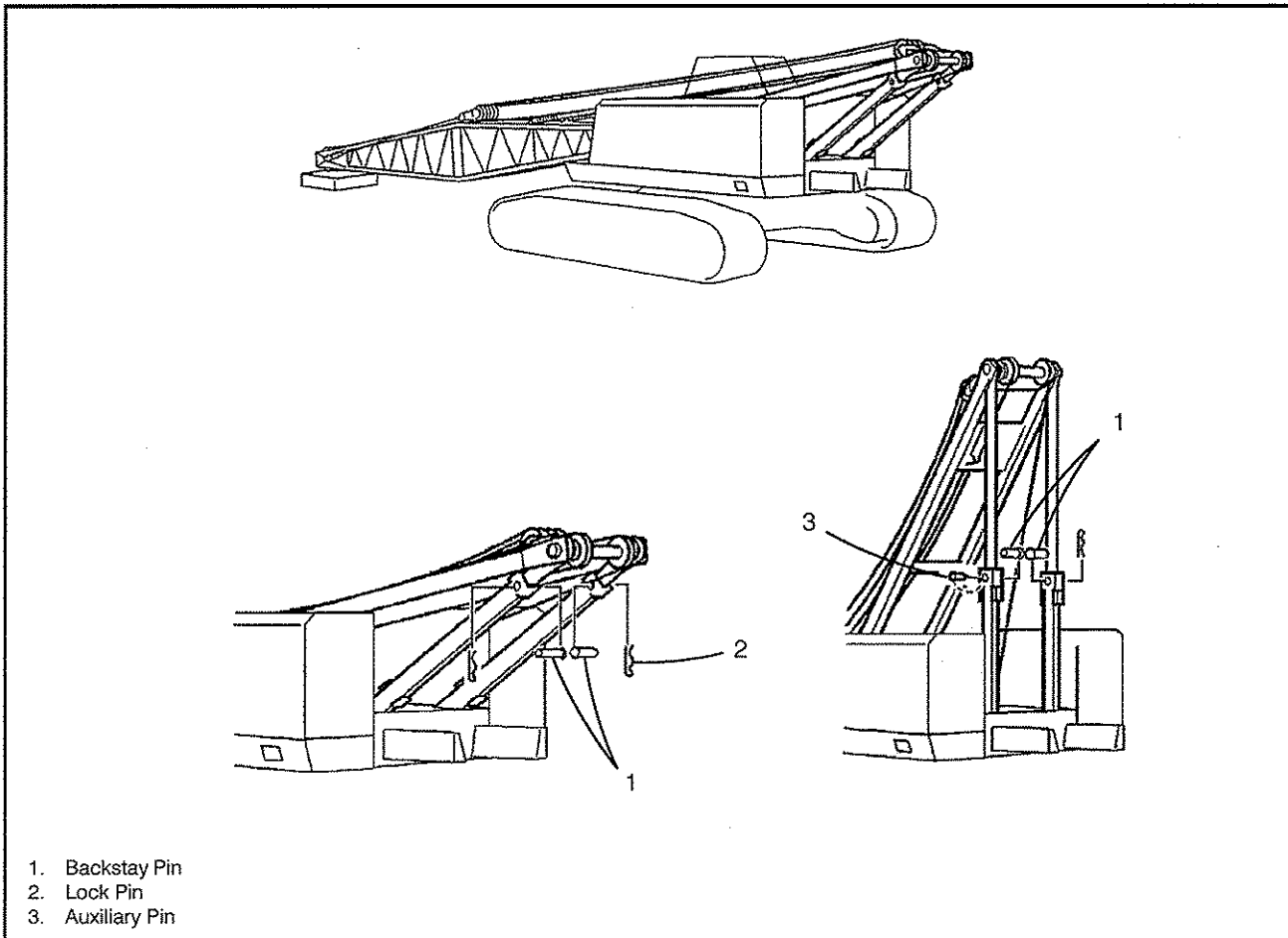

Figure 1-74
Raising And Lowering The Gantry Without Helper Crane

Raising The Gantry Without Helper Crane

1. Place the crane on firm, level ground and position the upper parallel to the side frames. Engage the travel swing lock.
2. Lower the boom onto secure blocking.
3. Move the boom hoist control lever to the "lower" position to fully relieve the tension from the boom hoist wire rope.
4. Remove the left backstay lock pin and pin and install auxiliary pin. Refer to Figure 1-74.
5. Remove the right backstay pin and lock pin.

Note: When removing the auxiliary pin, confirm that it is loose. If the pin cannot be removed smoothly, check that the boom hoist wire rope is loosened properly. If necessary, move boom hoist lever back and forth to free the pins.

6. Remove the auxiliary pin on the left side and properly store on gantry.
7. Move the boom hoist lever to the "hoist" position and slowly wind up the wire rope.



WARNING

Insert backstay pins from the inside to the outside of the struts. Install the lock pins on the outside.

8. When the gantry is extended to its stroke end, stop winding the boom hoist wire rope and install the right and left backstay pins and lock pins.

Operator's Manual

Lowering The Gantry Without Helper Crane

1. Place the crane on firm, level ground and position the upper parallel to the side frames. Engage the travel swing lock.
2. Lower the boom onto secure blocking keeping the boom hoist wire rope tight.

Note: If the pins are hard to remove, operate the boom hoist lever back and forth to free the pins.

3. Remove the backstay lock pin and pin from the left side. Refer to Figure 1-74.
4. Install the auxiliary pin.
5. Remove the right backstay pin.

Note: When removing the auxiliary pin, confirm that it is loose. If the pin cannot be removed smoothly, check that the boom hoist wire rope is loosened properly.

6. Remove the auxiliary pin and properly store on gantry.

CAUTION

The backstay and auxiliary pins must be removed before attempting to lower the gantry. Failure to remove the pins will cause damage to the backstops.

7. Move the boom hoist control lever to the "lower" position to let off boom hoist wire rope and lower the gantry.



WARNING

Insert backstay pins from the inside to the outside of the struts. Install the lock pins on the outside.

8. Install the right and left backstay pins and lock pins.

Operator's Manual

Overload Test	1-67
Help Function	1-68
Inspection	1-72
Daily Inspection	1-72
Monthly Inspection	1-72
Periodic Replacement Of The Internal Dry Cell Battery	1-73
Functions To Be Adjusted With The Crane Set-up Mode	1-74
Boom Radius/Angle Adjustment	1-75
Self-weight Adjustment	1-77
Resetting Self-weight Corrected Value	1-79
Boom Hoist Limit Stop And Boom Backstop Limit Stop Confirmation	1-80
Boom Angles for Activating Boom Upper Limit Stop	1-82
Automatic Limiting Function Charts	1-83
Operator's Seat	1-86
Entering And Exiting The Operator's Cab	1-86
Gate Lock Lever	1-86
Before Starting Operations	1-87
Engine Starting Procedure	1-87
Engine Shutdown	1-88
Break-In Period	1-88
General Operation	1-88
Lift Crane Operation	1-88
Duty Cycle Applications	1-89
Dragline Operation	1-89
Operating Tips For Dragline Operation	1-90
Fairleader Assembly	1-91
Clamshell Operation	1-92
Operating Tips For Clamshell Operation	1-92
Tagline Winder	1-93
Crane Assembly And Disassembly	1-94
Crane Assembly	1-94
Crane Disassembly	1-94