

- NOTE:  
ALL RELIEF VALVES EXCEPT SWING PORT RELIEFS SHOULD BE SET AT FULL ENGINE THROTTLE;  
SWING PORT RELIEFS SHOULD BE SET AT IDLE.
- | PILOT LINES |                  |
|-------------|------------------|
| 1           | REAR WINCH DOWN  |
| 2           | REAR WINCH UP    |
| 3           | BOOM DOWN        |
| 4           | BOOM UP          |
| 5           | SWING RIGHT      |
| 6           | SWING LEFT       |
| 7           | FRONT WINCH DOWN |
| 8           | FRONT WINCH UP   |
| 9           | TELE. EXTEND     |
| 10          | TELE. RETRACT    |

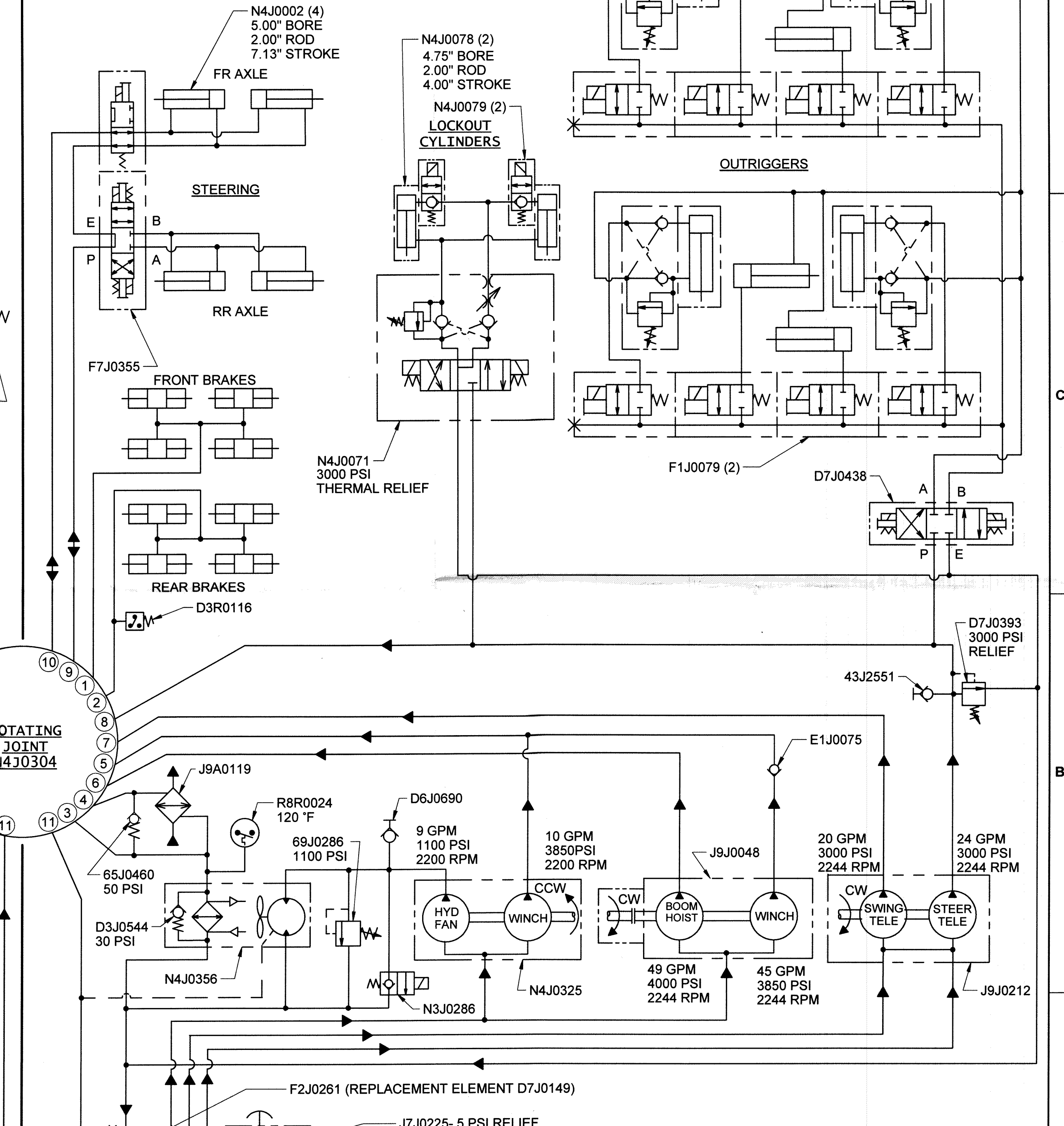

R11S401064		MADE FROM: S4J0001		Date	By	Check
E.O. Number	Zone	Rev	Revision Description	Date	By	Check
This drawing is the property of Link-Belt Construction Equipment Company and is transmitted in confidence. Reproduction, use or disclosure, in whole or part, of design and details contained herein is prohibited without written permission of Link-Belt Construction Equipment Company.						
Unless otherwise specified dimensions are in inches. The tolerances below are applicable unless otherwise specified.				Drawn	2/12/2013	Scale
ANGULAR ± 1°				Checked	None	Link-Belt CONSTRUCTION EQUIPMENT
DECIMAL				Approval		
X ± .1				Material	DWG HYD SCHEMATIC	
XX ± .06					EO Level	Rev
XXX ± .003					R11S401064	S4J0104 S
XXXX ± .0005					Weight	Sheet 1 of 2
CAD - Solid Edge						