

# TBA

## Turbo Blowers



### Features

- Integral molded scroll design
- Turbine bladed impeller
- Steel inlet guard
- Precisely balanced impellers eliminate vibration
- Complete line of available accessories for adapting to any piping condition or operational requirement
- More abrasion resistant than steel blower housing

### Benefits

- Efficiencies of up to 50% over conventional blowers
- Meets air volume and pressure requirements with smaller horsepower
- Reduced power consumption
- Easily rotated to any of 14 available positions
- Corrosion resistant for longer life



The Hauck direct drive Turbo Blower is available in six pressure ranges from 12–36 osig (5.2–15.5 kPa) and 63 different sizes ranging from 240 to 13,000 scfm (6.4–348 nm<sup>3</sup>/min) for providing large or small volumes of air at constant pressures. The Turbo Blower is designed to supply air for combustion or for any low pressure air application.

## HAUCK MANUFACTURING COMPANY

P.O. Box 90  
Lebanon, PA 17042  
Phone: 717-272-3051  
Fax: 717-273-9882  
[www.hauckburner.com](http://www.hauckburner.com)

***Combustion Excellence Since 1888***

**TBA-1**

# Hauck Manufacturing Company

TBA

Hauck manufactures an extensive line of fiberglass turbo blowers. Originally designed to provide combustion air, TBA blowers can be used on any application requiring low pressure air, such as: aerating, cooling, cleaning, conveying, fluidizing, exhausting, spraying, drying, ventilating, and agitating. The larger units provide both the increased capacity needed for larger furnaces as well as the higher pressures necessary for recuperation and flame shaping. Maximum inlet temperature is 200 °F (93 °C).

All Hauck Turbo Blowers have the integral molded scroll design and turbine bladed impeller that has proven itself so well over the years. The blowers produce efficiencies up to 50% over conventional blowers—efficiencies that mean savings in both initial and operating costs. Hauck TBA units can frequently meet your air volume and pressure requirements with a smaller horsepower than conventional blower equipment. Because of the increased efficiency, power consumption is reduced by several horsepower, reducing operating costs. TBA blowers are available with high efficiency or special duty motors.

The simple removal of eight bolts allows the casing and discharge to be rotated to any of seven positions. The rotation can easily be completed without disassembly of the casing. A steel inlet guard is furnished as standard equipment. If a motor replacement is ever necessary, standard shaft 'T' frame motors can be purchased locally, eliminating down time awaiting a special motor. Impellers balanced to ISO 1940 balancing standards minimize vibration to significantly increase the operational life of the blower. All Hauck Turbo Blowers are thoroughly tested prior to shipment.

A complete line of accessories is available which can adapt the Hauck Turbo Blower to almost any piping condition or operational requirement: inlet filters, silencers, combination filter-silencers, blast gates, transitions, starters, adapters, and more. Hauck Anti-Surge Control Systems (ASC) are available for new or existing installations where piping length or other conditions induce blower surge.

## DIMENSIONS

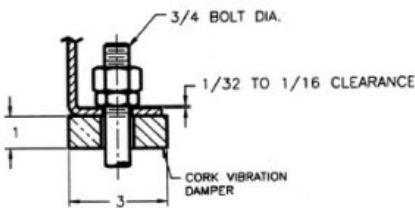
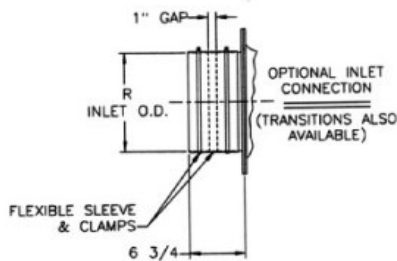

SECTION "A-A"

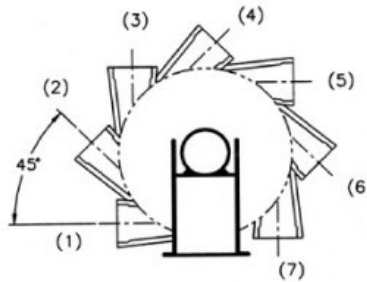

CLOCKWISE (CW)

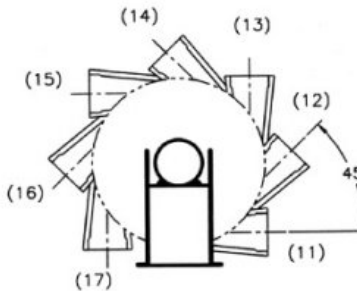

COUNTERCLOCKWISE (CCW)

AVAILABLE STANDARD DISCHARGE POSITIONS - MOTOR END

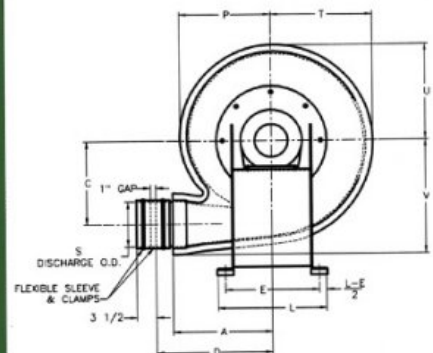
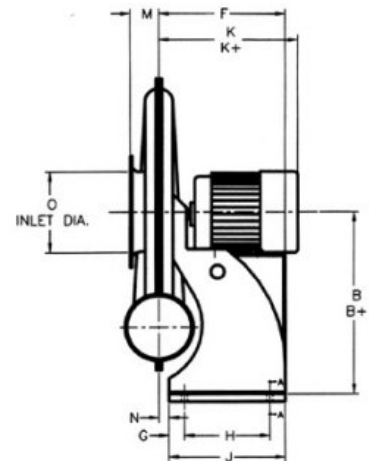

-

# Hauk Manufacturing Company

## CAPACITIES



Pressure Range (OSI)	Catalog Number	1.0 S.F. Motor Rating (TEFC)				1.15 S.F. Motor Rating (ODP)			
		SCFM	SCFH	Total Pressure (OSIG)	BHP	SCFM	SCFH	Total Pressure (OSIG)	BHP
12	TBA-12-1.5	240	14,400	12.0	1.5	305	18,300	11.4	1.8
	TBA-12-2	310	18,600	12.6	2	440	26,400	11.6	2.4
	TBA-12-3	500	30,000	12.7	3	-	-	-	-
	TBA-12-5	1,080	64,800	12.4	5	1,280	76,800	11.7	5.75
	TBA-12-7.5	1,600	96,000	12.4	7.5	2,040	122,400	11.5	8.6
	TBA-12-10	2,200	132,000	12.5	10	2,740	164,400	10.8	11.5
	TBA-12-15	3,050	183,000	12.6	15	3,750	225,000	11.9	17.25
	TBA-12-20	4,550	273,000	12.1	20	5,140	308,400	11.7	23
	TBA-12-25	5,050	303,000	12.1	25	5,775	346,500	11.0	28.75
TBA-12-30	5,775	346,500	12.0	30	6,575	394,500	11.0	34.5	
16	TBA-16-3	380	22,800	16.5	3	-	-	-	-
	TBA-16-5	740	44,400	16.0	5	900	54,000	15.2	5.75
	TBA-16-7.5	1,220	73,200	16.5	7.5	1,460	87,600	15.6	8.6
	TBA-16-10	1,620	97,200	16.6	10	1,920	115,200	15.5	11.5
	TBA-16-15	2,500	150,000	16.7	15	3,050	183,000	15.5	17.25
	TBA-16-20	3,250	195,000	16.7	20	3,750	225,000	15.0	23
	TBA-16-25	3,850	231,000	16.5	25	4,700	282,000	15.7	28.75
	TBA-16-30	4,600	276,000	16.3	30	5,600	336,000	15.0	34.5
	TBA-16-40	6,900	414,000	16.7	40	7,950	447,000	15.3	46
20	TBA-20-5	450	27,000	20.0	5	550	33,000	19.5	5.75
	TBA-20-7.5	850	51,000	20.0	7.5	1,040	62,400	18.9	8.6
	TBA-20-10	1,200	72,000	20.0	10	1,470	88,200	18.2	11.5
	TBA-20-15	2,100	126,000	20.8	15	2,500	150,000	19.4	17.25
	TBA-20-20	2,650	159,000	20.9	20	3,125	187,500	20.0	23
	TBA-20-25	3,380	202,800	20.8	25	3,975	238,500	19.5	28.75
	TBA-20-30	3,850	231,000	20.8	30	4,550	273,000	19.7	34.5
	TBA-20-40	5,000	300,000	20.8	40	5,650	339,000	19.5	44
	TBA-20-50	6,620	397,200	19.5	50	7,850	471,000	17.8	57.5
TBA-20-60	7,700	462,000	19.5	60	9,150	549,000	17.0	69	
24	TBA-24-5	235	14,100	22.8	5	350	21,000	23.4	5.75
	TBA-24-7.5	600	36,000	23.5	7.5	760	45,600	22.8	8.6
	TBA-24-10	1,000	60,000	24.0	10	1,200	72,000	23.7	11.5
	TBA-24-15	1,550	93,000	24.0	15	1,800	108,000	22.1	16.5
	TBA-24-20	2,350	141,000	24.9	20	2,760	165,600	23.9	23
	TBA-24-25	2,875	172,500	25.0	25	3,400	204,000	23.5	28.75
	TBA-24-30	3,350	201,000	25.8	30	3,925	235,500	25.1	34.5
	TBA-24-40	4,350	261,000	25.5	40	5,000	300,000	24.0	46
	TBA-24-50	5,600	336,000	25.4	50	6,650	399,000	24.0	57.5
TBA-24-60	6,500	390,000	24.8	60	7,700	462,000	23.0	69	
32	TBA-32-7.5	460	27,600	32.6	7.5	570	34,200	32.0	8.6
	TBA-32-10	625	37,500	32.3	10	760	45,600	29.5	11.5
	TBA-32-15	870	52,200	32.9	15	1,050	63,000	27.9	17.25
	TBA-32-20	1,100	66,000	32.3	20	1,310	78,600	27.0	23
	TBA-32-25	2,180	130,800	32.6	25	2,510	150,600	31.6	28.75
	TBA-32-30	2,620	157,200	33.1	30	3,100	186,000	31.5	34.5
	TBA-32-40	3,540	212,400	32.9	40	4,140	248,400	30.6	46
	TBA-32-50	4,300	258,000	31.6	50	5,050	303,000	27.6	57.5
	TBA-32-60	4,750	285,000	34.5	60	5,600	336,000	29.9	69
	TBA-32-75	6,050	363,000	32.2	75	7,050	424,200	29.8	86.25
	TBA-32-100	8,350	501,000	31.9	100	10,000	600,000	30.2	115
	TBA-32-125	10,300	618,000	31.8	125	11,700	672,000	31.1	143.75
	TBA-32-150	12,050	723,000	32.5	150	14,200	852,000	30.2	172.5
36	TBA-36-10	550	33,000	36.1	10	675	40,500	35.4	11.5
	TBA-36-15	850	51,000	35.8	15	1,010	60,600	31.9	17.25
	TBA-36-20	1,035	62,100	36.6	20	1,250	75,000	30.7	23
	TBA-36-25	1,940	116,400	35.8	25	2,360	141,000	34.9	28.75
	TBA-36-30	2,380	142,800	36.4	30	2,820	169,200	35.4	34.5
	TBA-36-40	3,300	198,000	35.7	40	3,875	232,500	33.9	46
	TBA-36-50	3,950	237,000	36.4	50	4,650	279,000	33.9	57.5
	TBA-36-60	4,600	276,000	36.7	60	5,425	325,500	33.2	69
	TBA-36-75	5,650	339,000	36.6	75	6,600	396,000	35.1	86.25
	TBA-36-100	7,275	436,500	35.8	100	8,125	487,500	34.1	115
	TBA-36-125	8,500	510,000	40.2	125	10,800	648,000	38.3	143.75
	TBA-36-150	11,500	690,000	37.2	150	14,500	870,000	32.6	172.5

NOTE: 1. Capacities at 29.92" Hg inlet pressure and 70°F inlet temperature.  
 2. All motors 60 Hz, 3600 rpm., standard shaft.

# Hauk Manufacturing Company

## DIMENSIONAL DATA

Pressure Range (OSIG)	Catalog Number	Volume (CFM)		HP	Motor Frame		Dimensions (Inches)						
		1.00 S.F.	1.15 S.F.		TEFC	ODP	A	B	B+	C	D	E	F
12	TBA-12-1.5	240	305	1.5	143T	143T	12 1/2	22	22	13	15 1/2	17	16 1/4
	TBA-12-2	310	440	2	145T	145T	17	22	22	13 3/4	20	17	16 1/4
	TBA-12-3	500	-	3	182T	-	17	-	23	13 3/4	20	17	16 1/4
	TBA-12-5	1,080	1,280	5	184T	182T	18	23	23	15 1/4	21	17	16 1/4
	TBA-12-7.5	1,600	2,040	7.5	213T	184T	20 1/4	23	23 1/4	16 3/4	23 1/4	17	16 3/4
	TBA-12-10	2,200	2,740	10	215T	213T	20 1/4	23 3/4	23 3/4	16 3/4	23 3/4	17	16 3/4
	TBA-12-15	3,050	3,750	15	254T	215T	20 1/2	25 1/4	26 1/4	17 1/4	23 1/2	21	23 3/4
	TBA-12-20	4,550	5,140	20	256T	254T	20 1/2	26 1/4	26 1/4	17 1/4	23 1/2	21	23 3/4
	TBA-12-25*	5,050	5,775	25	284TS	256T	20 1/2	26 1/4	27	17 1/4	23 1/2	21	24
	TBA-12-30*	5,775	6,575	30	286TS	284TS	20 1/2	27	27	17 1/4	23 1/2	21	24
16	TBA-16-3	380	-	3	182T	-	12 1/2	-	23	13	15 1/2	17	16 1/4
	TBA-16-5	740	900	5	184T	182T	17	23	23	13 3/4	20	17	16 1/4
	TBA-16-7.5	1,220	1,460	7.5	213T	184T	18	23	23 3/4	15 1/4	21	17	16 1/4
	TBA-16-10	1,620	1,920	10	215T	213T	18	23 3/4	23 3/4	15 1/4	21	17	16 1/4
	TBA-16-15	2,500	3,050	15	254T	215T	20 1/4	25 1/4	26 1/4	16 3/4	23 3/4	21	22 1/2
	TBA-16-20	3,250	3,750	20	256T	254T	20 1/4	26 1/4	26 1/4	16 3/4	23 3/4	21	22 1/2
	TBA-16-25	3,850	4,700	25	284TS	256T	20 1/2	26 1/4	27	17 1/4	23 1/2	21	23 3/4
	TBA-16-30	4,600	5,600	30	286TS	284TS	20 1/2	27	27	17 1/4	23 1/2	21	23 3/4
	TBA-16-40*	6,900	7,950	40	324TS	286TS	20 1/2	27	28	17 1/4	23 1/2	21	24
	20	TBA-20-5	450	550	5	184T	182T	18	23	23	15 1/2	21	17
TBA-20-7.5		850	1,040	7.5	213T	184T	20	23	23 3/4	16 1/4	23	17	16 1/4
TBA-20-10		1,200	1,470	10	215T	213T	20	23 3/4	23 3/4	16 1/4	23	17	16 1/4
TBA-20-15		2,100	2,500	15	254T	215T	22 1/4	25 1/4	26 1/4	18 1/4	25 1/4	21	22 1/2
TBA-20-20		2,650	3,125	20	256T	254T	20 1/4	26 1/4	26 1/4	19	23 3/4	21	22 1/2
TBA-20-25		3,380	3,975	25	284TS	256T	20 1/4	26 1/4	27	19	23 3/4	21	22 1/2
TBA-20-30		3,850	4,550	30	286TS	284TS	20 1/4	28 1/2	28 1/2	19 3/4	23 3/4	22 1/2	25 1/4
TBA-20-40		5,000	5,650	40	324TS	286TS	20 1/4	28 1/2	29 1/2	19 3/4	23 3/4	22 1/2	25 1/4
TBA-20-50		6,620	7,850	50	326TS	324TS	20 1/4	29 1/2	29 1/2	19 3/4	23 3/4	22 1/2	25 1/4
TBA-20-60		7,700	9,150	60	364TS	326TS	20 1/4	29 1/2	30 1/2	19 3/4	23 3/4	22 1/2	25 1/4
24	TBA-24-5	235	350	5	184T	182T	18	23	23	15 1/2	21	17	16 1/4
	TBA-24-7.5	600	760	7.5	213T	184T	18	23	23 3/4	15 1/4	21	17	16 1/4
	TBA-24-10	1,000	1,200	10	215T	213T	20	23 3/4	23 3/4	16 1/4	23	17	16 1/4
	TBA-24-15	1,550	1,800	15	254T	215T	20	25 1/4	26 1/4	16 1/4	23	21	22 1/2
	TBA-24-20	2,350	2,760	20	256T	254T	22 1/4	26 1/4	26 1/4	18 1/4	25 1/4	21	22 1/2
	TBA-24-25	2,875	3,400	25	284TS	256T	22 1/4	26 1/4	27	18 1/4	25 1/4	21	22 1/2
	TBA-24-30	3,350	3,925	30	286TS	284TS	20 1/4	27	27	19	23 3/4	21	22 1/2
	TBA-24-40	4,350	5,000	40	324TS	286TS	20 1/4	27	28	19	23 3/4	21	22 1/2
	TBA-24-50	5,600	6,650	50	326TS	324TS	20 1/4	29 1/2	29 1/2	19 3/4	23 3/4	22 1/2	25 1/4
	TBA-24-60	6,500	7,700	60	364TS	326TS	20 1/4	29 1/2	30 1/2	19 3/4	23 3/4	22 1/2	25 1/4
32	TBA-32-7.5	460	570	7.5	213T	184T	19	28 1/2	28 1/2	19	21 1/2	27 1/2	18 1/16
	TBA-32-10	625	760	10	215T	213T	19	28 3/4	28 3/4	19	21 1/2	27 1/2	18 1/16
	TBA-32-15	870	1,050	15	254T	215T	19	31 9/16	32 9/16	19	21 1/2	27 3/4	23 15/16
	TBA-32-20	1,100	1,310	20	256T	254T	19	32 9/16	32 9/16	19	21 1/2	27 3/4	23 15/16
	TBA-32-25	2,180	2,510	25	284TS	256T	21 1/4	32 9/16	33 5/16	22 1/2	24 3/4	27 1/2	23 15/16
	TBA-32-30	2,620	3,100	30	286TS	284TS	21 1/4	33 5/16	33 5/16	22 1/2	24 3/4	27 3/4	23 15/16
	TBA-32-40	3,540	4,140	40	324TS	286TS	24	33 5/16	34 5/16	22 1/2	26 1/2	27 3/4	24 3/4
	TBA-32-50	4,300	5,050	50	326TS	324TS	24	36 3/4	36 3/4	22 1/2	26 1/2	27 3/4	29 3/4
	TBA-32-60	4,750	5,600	60	364TS	326TS	24	36 3/4	37 3/4	22 1/2	26 1/2	27 3/4	29 3/4
	TBA-32-75	6,050	7,050	75	365TS	364TS	23 3/4	37 3/4	37 3/4	23 5/16	25 1/4	27 3/4	29 3/4
	TBA-32-100	8,350	10,000	100	405TS	365TS	25	38	39	24 1/2	27	28 3/4	35 3/4
	TBA-32-125	10,300	11,700	125	444TS	404TS	25	39	40	24 1/2	27	28 3/4	35 3/4
	TBA-32-150	12,050	14,200	150	445TS	405TS	25	39	40	24 1/2	27	28 3/4	35 3/4
36	TBA-36-10	550	675	10	215T	213T	19	28 3/4	28 3/4	19	21 1/2	27 3/4	18 1/16
	TBA-36-15	850	1,010	15	254T	215T	19	31 9/16	32 9/16	19	21 1/2	27 3/4	23 15/16
	TBA-36-20	1,035	1,250	20	256T	254T	19	32 9/16	32 9/16	19	21 1/2	27 3/4	23 15/16
	TBA-36-25	1,940	2,360	25	284TS	256T	21 1/4	32 9/16	33 5/16	22 1/2	24 3/4	27 3/4	23 15/16
	TBA-36-30	2,380	2,820	30	286TS	284TS	21 1/4	33 5/16	33 5/16	22 1/2	24 3/4	27 3/4	23 15/16
	TBA-36-40	3,300	3,875	40	324TS	286TS	24	33 5/16	34 5/16	22 1/2	26 1/2	27 3/4	24 3/4
	TBA-36-50	3,950	4,650	50	326TS	324TS	24	36 3/4	36 3/4	22 1/2	26 1/2	27 3/4	29 3/4
	TBA-36-60	4,600	5,425	60	364TS	326TS	24	36 3/4	37 3/4	22 1/2	26 1/2	27 3/4	29 3/4
	TBA-36-75	5,650	6,600	75	365TS	364TS	23 3/4	37 3/4	37 3/4	23 5/16	25 1/4	27 3/4	29 3/4
	TBA-36-100	7,275	8,125	100	405TS	365TS	23 3/4	38	39	23 5/16	25 1/4	28 3/4	35 3/4
	TBA-36-125	8,500	10,800	125	444TS	404TS	25	39	40	24 1/2	27	28 3/4	35 3/4
	TBA-36-150	11,500	14,500	150	445TS	405TS	25	39	40	24 1/2	27	28 3/4	35 3/4

NOTE: + Indicates TEFC motor  
 \*TBA-12-25, TBA-12-30, and TBA-16-40 available with C LOCKWISE (CW) discharge positions only.  
 Do not use for construction purposes. Certified dimensions available at time of order.



# Hauck Manufacturing Company

## ENGINEERING INFORMATION

### CORRECTION FACTOR TABLE

AIR TEMP (°F)	ALTITUDE (FT ABOVE SEA LEVEL)																						
	0	500	1000	1500	2000	2500	3000	3500	4000	4500	5000	5500	6000	6500	7000	7500	8000	8500	9000	10000			
-60	.75	.77	.78	.80	.81	.83	.84	.86	.87	.89	.90	.92	.94	.96	.98	1.00	1.02	1.03	1.05	1.07	1.08	1.11	1.15
-40	.79	.81	.82	.84	.85	.87	.89	.90	.92	.93	.95	.97	.99	1.00	1.03	1.05	1.07	1.08	1.11	1.15	1.15	1.15	1.15
-20	.83	.85	.86	.88	.90	.91	.93	.95	.96	.98	1.00	1.01	1.04	1.05	1.08	1.09	1.12	1.14	1.16	1.20	1.20	1.20	1.20
0	.87	.89	.91	.92	.94	.96	.98	.99	1.01	1.03	1.05	1.06	1.09	1.10	1.13	1.15	1.17	1.19	1.22	1.26	1.26	1.26	1.26
40	.94	.96	.98	1.00	1.02	1.04	1.06	1.08	1.10	1.12	1.14	1.16	1.19	1.21	1.23	1.26	1.28	1.30	1.32	1.36	1.36	1.36	1.36
70	1.00	1.02	1.04	1.06	1.08	1.10	1.12	1.14	1.16	1.18	1.20	1.22	1.25	1.27	1.30	1.32	1.35	1.37	1.40	1.45	1.45	1.45	1.45
80	1.02	1.04	1.06	1.08	1.10	1.12	1.14	1.16	1.19	1.21	1.23	1.26	1.28	1.30	1.33	1.36	1.38	1.41	1.43	1.48	1.48	1.48	1.48
100	1.06	1.08	1.10	1.12	1.14	1.16	1.19	1.21	1.23	1.25	1.28	1.30	1.33	1.35	1.38	1.41	1.43	1.46	1.48	1.54	1.54	1.54	1.54
120	1.09	1.12	1.14	1.16	1.18	1.20	1.23	1.25	1.28	1.30	1.32	1.35	1.38	1.40	1.43	1.46	1.48	1.51	1.53	1.60	1.60	1.60	1.60
140	1.13	1.15	1.18	1.20	1.22	1.25	1.27	1.29	1.32	1.34	1.37	1.40	1.42	1.45	1.48	1.51	1.54	1.57	1.58	1.66	1.66	1.66	1.66
160	1.17	1.19	1.22	1.24	1.26	1.29	1.31	1.34	1.36	1.39	1.42	1.44	1.47	1.50	1.53	1.56	1.59	1.62	1.64	1.72	1.72	1.72	1.72
180	1.21	1.23	1.26	1.28	1.30	1.33	1.36	1.38	1.41	1.43	1.46	1.49	1.52	1.55	1.58	1.61	1.64	1.67	1.70	1.78	1.78	1.78	1.78
200	1.25	1.27	1.29	1.32	1.34	1.37	1.40	1.42	1.45	1.48	1.51	1.54	1.57	1.60	1.63	1.66	1.69	1.72	1.75	1.82	1.82	1.82	1.82

The above composite table shows density correction factors for temperature and altitude. Performance ratings shown in this bulletin have been calculated for standard air density of .075 lb./cu. ft. (70 °F @ 29.92 in. Hg barometric pressure). When density is other than standard, corrections for pressure and horsepower must be made.

**Example:** Requirement—a blower to deliver 3850 cfm at 16 osi pressure at 120 °F and 2500 ft. altitude.

1. Density Correction table indicates a factor of 1.20 for 120 °F and 2500 ft. altitude.

2. 16 osi x 1.20 = 19.2 osi.
3. From capacity table on Page 3, select model TBA-20-30 (1.0 S.F.) showing a capacity of 3850 cfm @ 20.8 osi requiring a 30 HP motor at standard air.
4. Divide pressure and HP shown by 1.20 for performance at elevated temperature and altitude. Correct selection will deliver 3850 cfm at 17.3 osi at 120 °F and 2500 ft. altitude with a 25 HP motor. Select a TBA-20-30 with a 25 HP motor unless unit must start up cold, in which case use of a 30 HP motor is required.

### PRESSURE CONVERSION TABLE

OSI to IN. WC				IN. WC to OSI			
OSI	* WC	OSI	* WC	* WC	OSI	* WC	OSI
1	1.73	36	62.28	1	.57	36	20.81
2	3.46	38	65.74	2	1.16	38	21.97
4	6.92	40	69.20	4	2.31	40	23.12
6	10.38	42	72.66	6	3.47	42	24.28
8	13.84	44	76.12	8	4.62	44	25.43
10	17.30	46	79.58	10	5.78	46	26.59
12	20.76	48	83.04	12	6.94	48	27.75
14	24.22	50	86.50	14	8.09	50	28.90
16	27.68	52	89.96	16	9.25	52	30.06
18	31.14	54	93.42	18	10.40	54	31.21
20	34.60	56	96.88	20	11.56	56	32.27
22	38.06	58	100.34	22	12.72	58	33.53
24	41.52	60	103.80	24	13.84	60	34.68
26	44.98	62	107.26	26	15.03	62	35.84
28	48.44	64	110.72	28	16.18	64	36.99
30	51.90	66	114.18	30	17.34	66	38.15
32	55.36	68	117.64	32	18.50	68	39.31
34	58.82	70	121.10	34	19.65	70	40.46

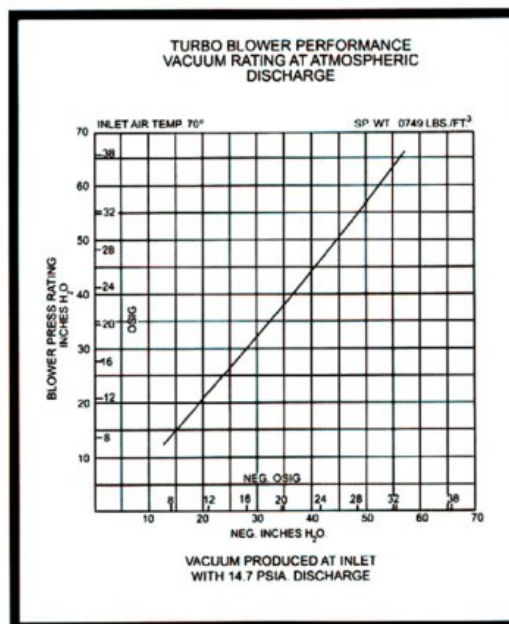

# Hauck Manufacturing Company

## ENGINEERING INFORMATION

### CORRECTION FACTOR TABLE

AIR TEMP (°F)	ALTITUDE (FT ABOVE SEA LEVEL)																			
	0	500	1000	1500	2000	2500	3000	3500	4000	4500	5000	5500	6000	6500	7000	7500	8000	8500	9000	10000
-60	.75	.77	.78	.80	.81	.83	.84	.86	.87	.89	.90	.92	.94	.96	.98	1.00	1.02	1.03	1.06	1.09
-40	.79	.81	.82	.84	.85	.87	.89	.90	.92	.93	.95	.97	.99	1.00	1.03	1.05	1.07	1.08	1.11	1.15
-20	.83	.85	.86	.88	.90	.91	.93	.95	.96	.98	1.00	1.01	1.04	1.05	1.08	1.09	1.12	1.14	1.16	1.20
0	.87	.89	.91	.92	.94	.96	.98	.99	1.01	1.03	1.05	1.06	1.09	1.10	1.13	1.15	1.17	1.19	1.22	1.26
40	.94	.96	.98	1.00	1.02	1.04	1.06	1.08	1.10	1.12	1.14	1.16	1.19	1.21	1.23	1.26	1.28	1.30	1.32	1.36
70	1.00	1.02	1.04	1.06	1.08	1.10	1.12	1.14	1.16	1.18	1.20	1.22	1.25	1.27	1.30	1.32	1.35	1.37	1.40	1.45
80	1.02	1.04	1.06	1.08	1.10	1.12	1.14	1.16	1.19	1.21	1.23	1.26	1.28	1.30	1.33	1.36	1.38	1.41	1.43	1.48
100	1.06	1.08	1.10	1.12	1.14	1.16	1.19	1.21	1.23	1.25	1.28	1.30	1.33	1.35	1.38	1.41	1.43	1.46	1.48	1.54
120	1.09	1.12	1.14	1.16	1.18	1.20	1.23	1.25	1.28	1.30	1.32	1.35	1.38	1.40	1.43	1.46	1.48	1.51	1.53	1.58
140	1.13	1.15	1.18	1.20	1.22	1.25	1.27	1.29	1.32	1.34	1.37	1.40	1.42	1.45	1.48	1.51	1.54	1.57	1.58	1.65
160	1.17	1.19	1.22	1.24	1.26	1.29	1.31	1.34	1.36	1.39	1.42	1.44	1.47	1.50	1.53	1.56	1.59	1.62	1.64	1.70
180	1.21	1.23	1.26	1.28	1.30	1.33	1.36	1.38	1.41	1.43	1.46	1.49	1.52	1.55	1.58	1.61	1.64	1.67	1.70	1.75
200	1.25	1.27	1.29	1.32	1.34	1.37	1.40	1.42	1.45	1.48	1.51	1.54	1.57	1.60	1.63	1.66	1.69	1.72	1.75	1.81

The above composite table shows density correction factors for temperature and altitude. Performance ratings shown in this bulletin have been calculated for standard air density of .075 lb./cu. ft. (70 °F @ 29.92 in. Hg barometric pressure). When density is other than standard, corrections for pressure and horsepower must be made.

**Example:** Requirement—a blower to deliver 3850 cfm at 16 osi pressure at 120 °F and 2500 ft. altitude.

1. Density Correction table indicates a factor of 1.20 for 120 °F and 2500 ft. altitude.

2. 16 osi x 1.20 = 19.2 osi.
3. From capacity table on Page 3, select model TBA-20-30 (1.0 S.F.) showing a capacity of 3850 cfm @ 20.8 osi requiring a 30 HP motor at standard air.
4. Divide pressure and HP shown by 1.20 for performance at elevated temperature and altitude. Correct selection will deliver 3850 cfm at 17.3 osi at 120 °F and 2500 ft. altitude with a 25 HP motor. Select a TBA-20-30 with a 25 HP motor unless unit must start up cold, in which case use of a 30 HP motor is required.

### PRESSURE CONVERSION TABLE

OSI to IN. WC				IN. WC to OSI			
OSI	" WC	OSI	" WC	" WC	OSI	" WC	OSI
1	1.73	36	62.28	1	.57	36	20.81
2	3.46	38	65.74	2	1.16	38	21.97
4	6.92	40	69.20	4	2.31	40	23.12
6	10.38	42	72.66	6	3.47	42	24.28
8	13.84	44	76.12	8	4.62	44	25.43
10	17.30	46	79.58	10	5.78	46	26.59
12	20.76	48	83.04	12	6.94	48	27.75
14	24.22	50	86.50	14	8.09	50	28.90
16	27.68	52	89.96	16	9.25	52	30.06
18	31.14	54	93.42	18	10.40	54	31.21
20	34.60	56	96.88	20	11.56	56	32.27
22	38.06	58	100.34	22	12.72	58	33.53
24	41.52	60	103.80	24	13.84	60	34.68
26	44.98	62	107.26	26	15.03	62	35.84
28	48.44	64	110.72	28	16.18	64	36.99
30	51.90	66	114.18	30	17.34	66	38.15
32	55.36	68	117.64	32	18.50	68	39.31
34	58.82	70	121.10	34	19.65	70	40.46

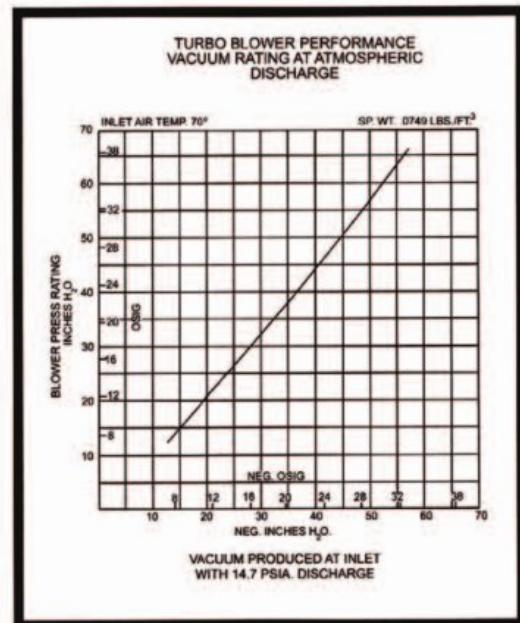



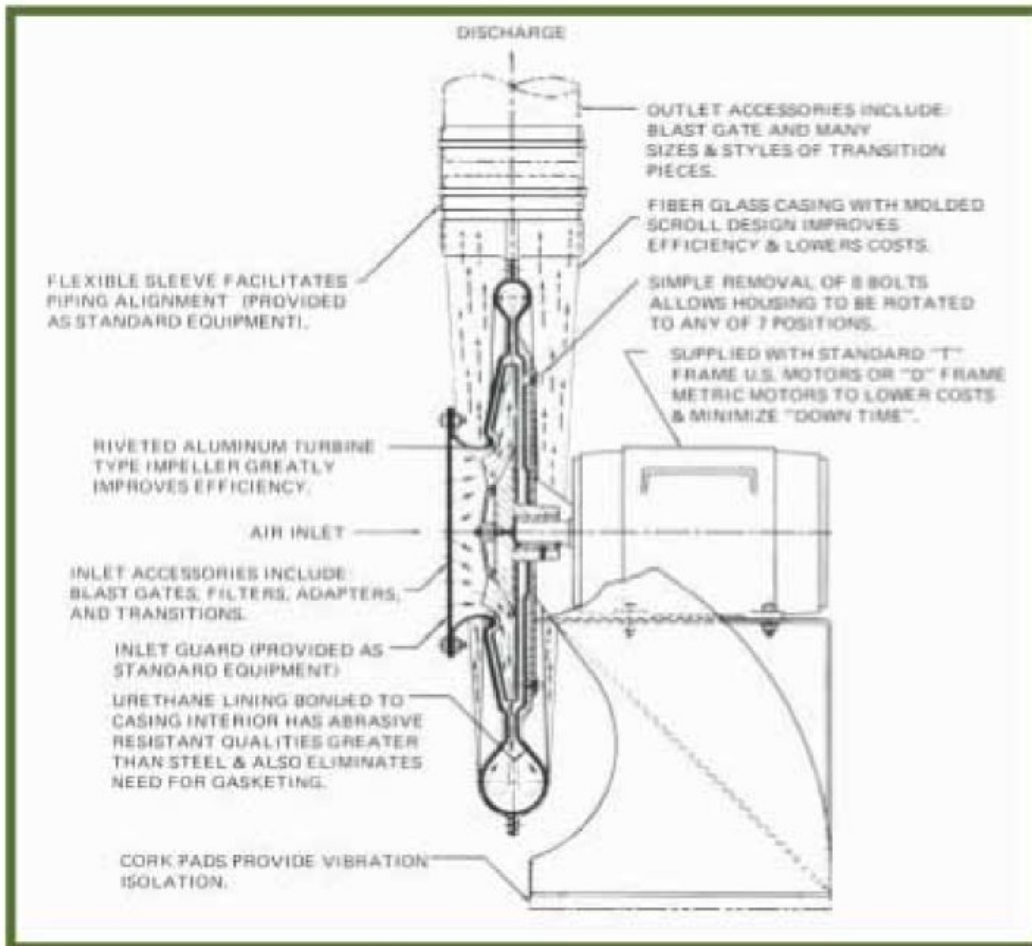

Lighter weight, corrosion resistance and a precisely molded involute scroll design are all made possible with the fiberglass casing. In addition, the molded rubberized lining provides abrasion resistance greater than steel and a super smooth surface for reduced frictional losses. Maximum inlet air temperature 200 °F (93 °C).

The riveted, heavy gauge aluminum turbine type impeller utilizes a curved blade design which induces air into the blower inlet and improves efficiency.

If a motor replacement is ever necessary, standard shaft 'T' frame motors can be purchased locally and eliminate 'downtime' awaiting a special motor.

The simple removal of eight bolts allows the casing and discharge to be rotated to any of seven positions. This rotation can be easily completed without disassembly of the casing.



**Turbine Design  
Impeller**  
(Pat. No. 3,472,967)



**Inlet Turning  
Ring Seal**  
(Pat. No. 3,572,963)

The exclusive curved impeller with built-in air inducer is coupled with a patented inlet turning ring seal to produce operating efficiencies that have been previously unobtainable in Turbo Pressure Blowers. A steel inlet guard is furnished as standard equipment (not shown).



### SILENCERS

The Hauck Inlet Silencer is specifically engineered to provide noise attenuation in the 63 Hz to 8,000 Hz frequency range. The design and the construction materials used ensure a long, trouble-free service life. Pressure drop is less than 1" wc (249 Pa). Use of a studded flange simplifies attachment to the blower. (See Hauck Sheet TBFS-1)



### FILTERS

The Hauck Filter is designed for blowers installed in a dirty atmosphere to prevent dirt from being drawn into the blower and air piping system. The use of an inlet filter can often prevent unbalanced impellers and inefficient blower operation. Minimal pressure drop. Compatible with Hauck Silencers. (See Hauck Sheet TBFS-1)



### TRANSITIONS, INTAKE ADAPTERS

All sizes and types of transition pieces are available to facilitate connecting the blower outlet to the system piping. The transition inlet is designed to fit the blower sleeve while the outlet is available with flanged, welded, threaded, or straight connections. An inlet adapter is available for applications where outside or 'fresh air' must be piped to the blower inlet. Adapter is complete with gasket and necessary fasteners.



### ANTI-SURGE CONTROLS

The Hauck Anti-Surge Control System is composed of a variable vane damper that is attached to the turbo blower inlet flange. Vane position is automatically determined by the system demand. Blower surge is automatically controlled by modulating the pressure drop across the inlet dampers, maintaining a constant discharge pressure. Vane pre-swirl reduces blower HP at part load, and generates a different performance curve at each damper position. This technique, applicable to new or existing installations alike, maintains the flow through the system ABOVE the flow that would allow surging. Additional information on operational theory and application is available in Hauck Application Sheet GJ61.

### HIGH EFFICIENCY AND SPECIAL DUTY MOTORS (Optional)

### VIBRATION ISOLATORS

### BLAST GATES

### ORDERING INFORMATION

To insure prompt and accurate processing of your order, the following information is required:

1. Catalog Number—from Capacity Table.\*
2. Discharge Position—from Dimensional Drawing (Discharge Position 1 supplied if not specified).

\* Selection information for special altitude or inlet air temperatures condition is presented on page 6.

3. Motor Type—ODP or TEFC. High efficiency or special duty motors (Optional).
4. Electrical Specification—Voltage and Phase—All blowers use 60 Hz 3600 rpm standard shaft motors.
5. Optional Accessories Desired (See TBFS-1).\*\*

\*\* Select accessories compatible with inlet and discharge sizes listed in columns O,R, and S in Dimensional Data. (See page 5).