



Operating Instructions

Profibus DP V1



FCM 300

FCD 300

VLT[®] 2800

■ Contents

Introduction	2
Quick Start	4
Profibus DP	4
Baudrate	4
Profibus DP V1	4
System layout	5
Master-controlled frequency converters	5
Bus topology	6
Features of DP (Distributed Periphery)	6
Rapid Cyclical transmission with PPO using DP	6
Profibus DP V1	7
Principle of data exchange by Profibus DP V0/DP V1	7
The Profibus Interface	9
Cable connection FCM 300	11
Cable connection FCD 300	14
Cable connection VLT 2800	17
Profibus DP	20
DP V1 identifications	30
Parameters	31
Warnings and alarm messages	39
Station address	41
Glossary	42
Parameter list	43
Index	50

■ Introduction

Copyrights, Limitation of Liability and Revision Rights.

This publication contains information proprietary to Danfoss A/S. By accepting and using this manual the user agrees that the information contained herein will be used solely for operating equipment of Danfoss A/S or equipment from other vendors provided that such equipment is intended for communication with Danfoss equipment over a PROFIBUS serial communication link. This publication is protected under the Copyright laws of Denmark and most other countries.

Danfoss A/S does not warrant that a software program produced according to the guidelines provided in this manual will function properly in every physical, hardware or software environment.

Although Danfoss A/S has tested and reviewed the documentation within this manual, Danfoss A/S makes no warranty or representation, either express or implied, with respect to this documentation, including its quality, performance, or fitness for a particular purpose.

In no event shall Danfoss A/S be liable for direct, indirect, special, incidental, or consequential damages arising out of the use, or the inability to use information contained in this manual, even if advised of the possibility of such damages. In particular, Danfoss A/S is not responsible for any costs including but not limited to those incurred as a result of lost profits or revenue, loss or damage of equipment, loss of computer programs, loss of data, the costs to substitute these, or any claims by third parties.

Danfoss A/S reserves the right to revise this publication at any time and to make changes in its contents without prior notice or any obligation to notify previous users of such revisions or changes.

When reading through this manual, you will come across various symbols that require special attention.

The symbols used are the following:



Indicates a general warning.



NB!:

Indicates something to be noted by the reader.



Indicates a high-voltage warning.

PROFIBUS is a registered trademark.

■ About this manual

This manual describes the Profibus communication in the following products:

- FCM 300
- FCD 300
- VLT 2800

The following table shows from which software versions Profibus DPV1 is supported. The software version can be read-out in parameter 624 **Software versions**.

Unit	Software version
FCM 300	Not supported
FCD 300	Ver. 1.3x/2.x
VLT 2800	Ver. 2.6x/2.x

This manual gives detailed information of the DP V0 features supported, sufficient for most programming and maintenance activities. The DP V1 however is briefly described. For programming purposes the **Profibus DP V1 Design Guide** order number MG.90.EX.YY (X is the version number, and YY the language code) might be necessary.

It is suggested that readers who are not completely familiar with PROFIBUS DP or the profile for frequency converters review the relevant literature on these subjects.

Even if you are an experienced PROFIBUS programmer, we suggest that you read this manual in its entirety before you start programming, since important information can be found in all chapters.

■ Assumptions

This manual assumes that you are using a DANFOSS FCM 300, FCD 300 or VLT 2800 with PROFIBUS. It is also assumed that you, as a master, are using a PLC or PC that is equipped with a serial communication card supporting all the PROFIBUS communication services required by your application. Further, it is assumed that all requirements stipulated in the PROFIBUS standard as well as those set up in the PROFIBUS frequency converters Profile and its company-specific implementation PROFIDRIVE, as well as those pertaining to the frequency converter are strictly observed as well as all limitations therein fully respected.

The Profibus DP V1 replaces the former Profibus DP V0 functionality.

Note: The 3MB and 12MB Profibus option are separate options and have different ordering numbers.

■ **What you should already know**

The DANFOSS PROFIBUS is designed to communicate with any master abiding by the PROFIBUS DP standard. It is therefore assumed that you have full knowledge of the PC or PLC you intend to use as a master in your system. Any questions pertaining to hardware or software produced by any other manufacturer is beyond the scope of this manual and is of no concern to DANFOSS.

If you have questions about how to set up master - master communication or communication to a non-Danfoss slave, the appropriate manuals should be consulted.

■ Quick start

Details regarding the programming of the usual frequency converter parameters may be gathered from the Design Guide for the FCM 300, the FCD 300 and VLT 2800.

The communication is established by setting the parameters indicated below.

Details regarding the adjustment of the master are provided by the master manual and by those chapters in this manual that deal with the particulars of the VLT PROFIBUS interface.



NB!:

The required GSD file is available on the internet at <http://www.danfoss.com/drives>.

Module consistency means that a specific portion of the PPO is defined as a connected module. The parameter interface (PCV, length of 8 bytes) of the PPO always has module consistency.

Word consistency means that a specific portion of the PPO is divided into individual data sectors of word length (16 bits).

The process data of the PPO may have either module consistency or word consistency, as desired.

Some PLCs, such as Siemens S7, require special functions to call modules that are longer than 4 bytes (in the case of Siemens: "SFC", see master manual). This means that the PCV interfaces of the PPOs can only be called through the SFC functions in the case of Siemens (S7).

■ Profibus DP

Parameter 904

The desired informative data telegram (PPO) is setup in master configuration. The actual PPO type can be read out in P904. The master sends the PPO type in a configuration telegram in the Profibus DP start phase.

Parameter 918

This sets the address of the frequency converter station – one specific address per frequency converter. For further information, please refer to the section Station address in this manual.

Parameter 502 -508

By setting the parameters 502-508 you will be able to select have to control over the bus.

Parameter 512

Allows the choice of Control word/Status word type. For further information, please refer to the section Control word/Status word this manual.



NB!:

In order to activate a change of parameter 918 the power of the frequency converter must be cycled.

■ Profibus DP V1

A detailed description of the DV V1 features supported can be found in the "Profibus DP V1 Design Guide" order number MG.90.EX.YY.

Further specifications might be helpful:

- Technical Guide "PROFIBUS -DP Extensions to EN 50170 (DPV1)" V2.0, April 1998, Order no. 2.082
- Draft PROFIBUS Profile PROFIDRIVE Profile Drive Technology V3.0 September 2000, Order no. 3.172

■ Baudrate

The FCM 300, FCD 300 and VLT 2800 adjust automatically to the Baudrate configured from the master.



NB!:

When configuring the PPO types, a distinction is made between module consistency and word consistency:

■ Master-controlled frequency converters

The PROFIBUS Fieldbus was designed to give you unprecedented flexibility and command over your controlled system. The PROFIBUS will perform as an integrated part of your frequency converter, giving you access to all parameters relevant to your application. The frequency converter will always act as a slave, and together with a master it can exchange a multitude of information and commands. Control signals such as speed reference, start / stop of motor, reverse operation, etc. are transmitted from the master in the form of a telegramme. The frequency converter acknowledges receipt by transmitting status signals, such as running, on reference, motor stopped and so on to the master. The frequency converter may also transmit fault indications, alarms and warnings to the master, such as Overcurrent or Phaseloss.

The PROFIBUS communicates in accordance with the PROFIBUS field bus standard, EN 50170, part 3. It can thus exchange data with all masters that meet this standard; however, this does not mean that all services available in the PROFIDRIVE profile standard are supported. The PROFIBUS profile for frequency converters (version 2 and partly version 3, PNO) is a part of PROFIBUS which supports only those services that concern applications with speed control.

Communication partners

In a control system the frequency converter will always act as a slave, and as such it may communicate with a single master or multiple masters depending on the nature of the application. A master may be a PLC or a PC that is equipped with a PROFIBUS communication card.

■ Bus topology

Single master operation with DP V0

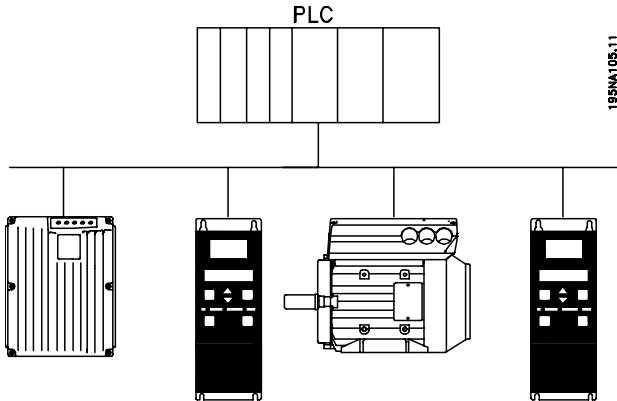

- Single master
- PLC communicates with telegrams of constant length
- Fits to time critical requirements

Cyclical transmission (PLC)

1. Setpoint transmission
2. Actual value feedback
3. New set points computed
4. New set point transmission
5. Parameter Read - using PCV channel
6. Parameter Write - using PCV channel
7. Read parameter description - using PCV channel

■ Features of DP (Distributed Periphery)

- Is used by several PLC manufacturers for remote peripheral I/O communication.
- Supports cyclical communication.
- SRD (Send Receive Data) service gives fast cyclical exchange of process data between master and slaves.
- Freeze and synchronize function is supported.
- Fixed data structure.
- Fixed telegramme size.
- Occupies I/O memory space in PLC proportional to the number of slaves employed, which may

limit the number of participants. Additional data require additional I/O memory space.

DP should be used when fast cyclical process control is needed. Such a concept would typically call for single master operation with a limited number of slave stations. A high number of slaves will increase the system response time.

This could also be the case where control loops are closed over the bus. As a very fast alternative it is of course possible to close the control loop outside the bus.

■ Rapid Cyclical transmission with PPO using DP

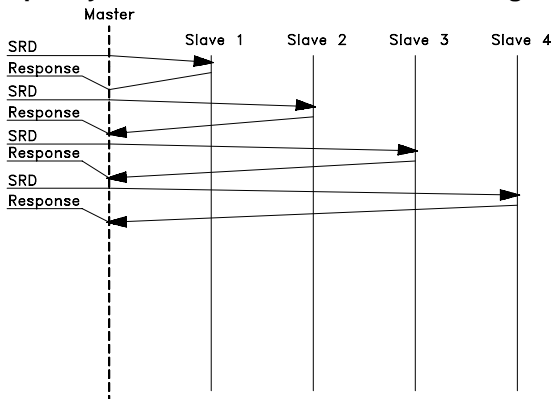

Control of the drives during normal operation is often very time critical, but it involves very few data, such as control commands and speed reference. DP is optimized for fast cyclical communication.

Parameter up-/downloads can be achieved by using the PCV part of the so-called Parameter - Process data Objects - PPO types 1, 2 or 5, see drawing in paragraph PPO description.

■ Profibus DP V1

The Profibus DP extension DP V1 offers additional to the cyclical data communication an acyclical communication. This feature can be used by a DP master type 1 (e.g. PLC), as well as a DP master type 2 (e.g. PC tool).

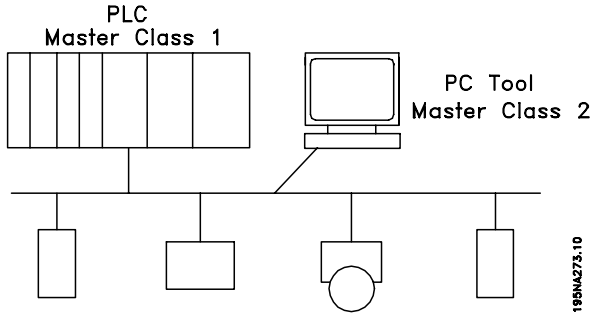

Features of a Master type 1 connection

- Cyclical data exchange (DP V0).
- Acyclical read/write on parameters.

The acyclical connection is fixed, and can not be changed during operation.

Features of a Master type 2 connection:

- Initiate / Abort acyclical connection.
- Acyclical read/write on parameters.

The acyclical connection can dynamically be established (Initiate) or removed (Abort) even when a master class 1 is active on the network.

The DP V1 acyclical connection can be used for general parameter access as an alternative to the PCV parameter channel.

■ Principle of data exchange by Profibus DP V0/DP V1

In a DP cycle the MC 1 will first update the cyclical process data for all slaves in the system. After that the MC 1 has the possibility of sending one acyclical message to one slave. If a MC 2 is connected, the MC 1 will handle over the Token to MC 2 who now is aloud to send one acyclical message to one slave. After that, the token is handed back to the MC 1, and a new DP cycle is started.

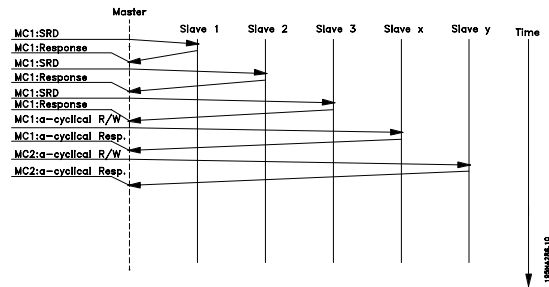

MC1: Master Class 1

Closing the control loop over the bus

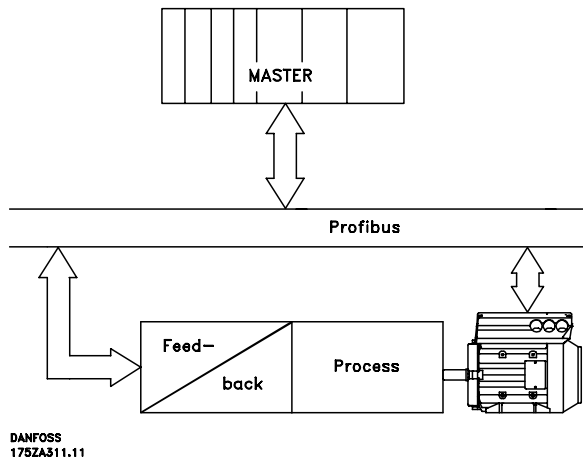

Closing the control loop outside the fieldbus for extremely fast feed-back

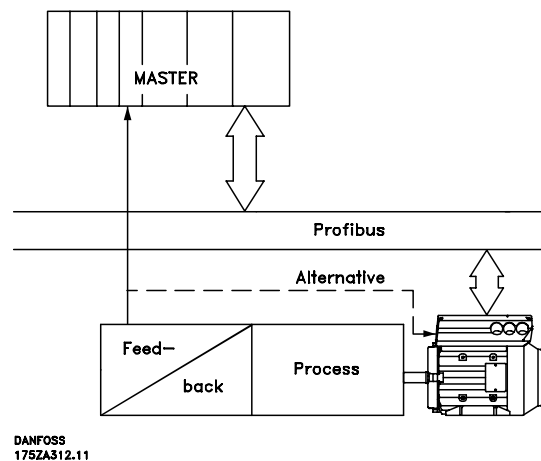

System layout

■ FCM 300/FCD 300/VLT 2800 response time

The update time via the prodibus connection can be divided in two parts: 1) The communication time, which is the time it takes to transmit data from the master to the slave (FCM 300/FCD 300/VLT 2800 with profibus), and 2) the internal update time, which is the time it takes to transmit data between the FCM 300/FCD 300/VLT 2800 control card and the profibus.

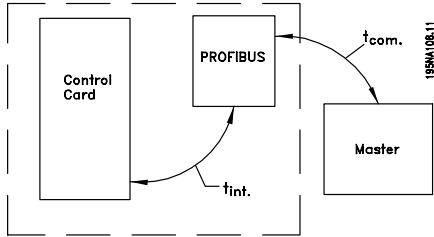

Communication time (t_{com}) depends on the actual transmission speed (baudrate) and the type of master in use. The minimum obtainable communication time with the FCM 300/FCD 300/VLT 2800 with PROFIBUS is approx. 100 msec per slave, when using DP communication with 4 bytes of data (PPO type 3) at 3 Mbaud. More data or lower transmission speed will increase the communication time.

The internal update time (t_{int}) depends on the type of data in question as there are different channels for the data transfer where time critical data e.g. control word has highest priority. The internal update time for the different types of data are stated below.

Data	Update time, t_{int}	
	FCD 300/ VLT 2800	FCM 300
Control word/Main reference (part of PPO)	Max. 26 msec.	Max. 65 msec.
Status word/Actual output frequency (part of PPO)	Max. 26 msec.	Max. 65 msec.
Parameter read (PCD 1-8)	40 msec.	40 msec.
Parameter write (PCD 1-2)	160 msec.	160 msec.
Parameter write (PCD 3-4)	320 msec.	320 msec.
Parameter write (PCD 5-8)	640 msec.	640 msec.
Parameter read (PCV)	41 msec.	41 msec.
Parameter write (PCV)	40 msec.	40 msec.
Acyclical data (single read, write)	-	40 msec.

■ System update time

The system update time is the time it takes to update all the slaves in the network when using

cyclical communication. The drawing below shows the value which is obtainable in theory at 2 input and 2 output bytes.

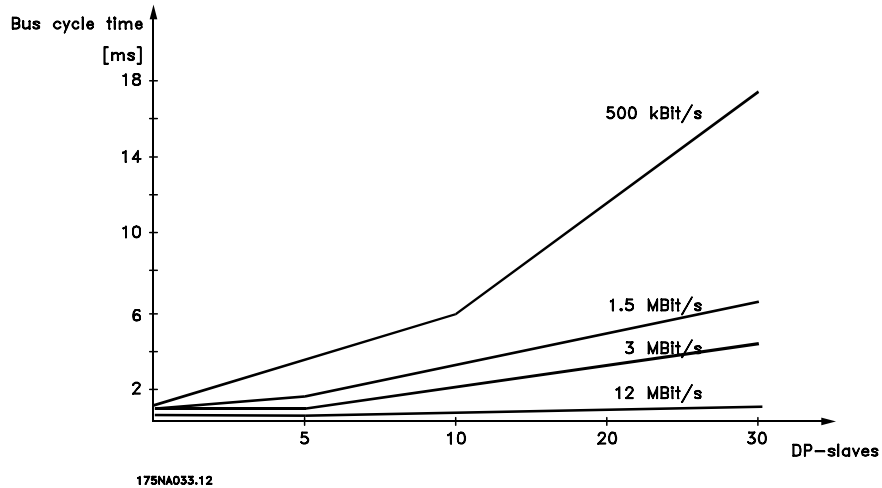

The Profibus Interface

The total drop cable length for one segment is limited as stated in the table below.

Drop cable length	
Transmission speed	Max. drop cable length per segment [m]
9.6-93.75 kBaud	96
187.5 kBaud	75
500 kBaud	30
1.5 mBaud	10
3-12 MBaud	none

The length statements in the tables above are valid provided that bus cable with the following properties is used:

- Impedance: 135 to 165 ohm at a measuring frequency from 3 to 20 MHz
- Resistance: < 110 ohm/km
- Capacity: < 30 pF/m
- Damping: max. 9 dB over the whole wire length
- Cross section: max. 0.34 mm², corresponding to AWG 22
- Cable type: twisted in pairs, 1 x 2, or 2 x 2, or 1 x 4 wires
- Screening: Copper-braided screen or braided screen and foil screen

It is recommended to use the same cable type in the entire network to avoid impedance mismatch.

The numbers on the following drawing indicate the maximum number of stations in each segment. They are not the station addresses as each station in the network must have a unique address.

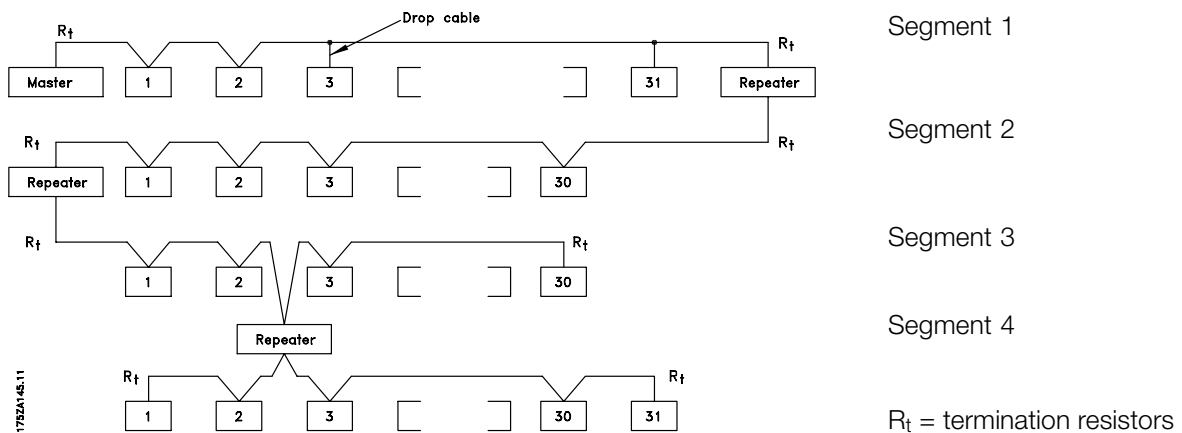

■ Cable lengths/ number of nodes

The maximum cable length in one segment is depending on the transmission speed. The total cable length includes drop cables if any. A drop cable is the connection from the main bus cable to each node if a T-connection is used instead of connecting the main bus cable directly to the nodes, see drop cable length. The table below shows the maximum allowed cable length and maximum number of nodes/frequency converters with 1, 2, 3 and 4 bus segments. Note that a repeater is a node in both of the two segments it connects. The number of frequency converters is based on a single master system. If

there are more masters the number of frequency converters must be reduced correspondingly.

FCM 300 / FCD 300 / VLT® 2800 / DP V1 PROFIBUS

Max. total bus cable length

Transmission speed	1 segment: 32 nodes (31 VLT) [m]	2 segments: 64 nodes (1 repeater, 61 VLT) [m]	3 segments: 96 nodes (2 repeaters, 91 VLT) [m]	4 segments: 128 nodes (3 repeaters, 121 VLT) [m]
9.6-187.5 kBaud	1000	2000	3000	4000
500 kBaud	400	800	1200	1600
1.5 MBaud	200	400	600	800
3 - 12 MBaud	100	200	300	400

Physical connection

The PROFIBUS is connected to the bus line via X100, terminals 1 and 2.

It is recommended to use a master with a galvanic isolated bus driver and with over voltage protection (e.g. zenerdiode).

EMC precautions

The following EMC precautions are recommended to obtain interference free operation of the PROFIBUS network. Additional information on EMC can be found in the design guide on the FCM 300 (MG.03.BX.02). Please also consult the manual of the PROFIBUS master for further installation guidelines.

Connection of the cable screen

The screen of the PROFIBUS cable must always be connected to ground at both ends, that means the screen must be connected to ground in all stations connected to the PROFIBUS network. It is very important to have a low impedance ground connection of the screen, also at high frequencies. This can be obtained by connecting the surface of the screen to ground, for example by means of a cable clamp or a conductive cable gland.

The FCM 300 Series is provided with different clamps and brackets to enable a proper ground connection of the PROFIBUS cable screen. The screen connection is shown in the following drawing.



NB!:

Relevant national and local regulations, for example regarding protective earth connection, must be observed.

Cable connection FCM 300

The PROFIBUS communication cable must be kept away from motor and brake resistor cables to avoid coupling of high frequency noise from one cable to the other. Normally a distance of 200 mm is sufficient, but it is generally recommended to keep the greatest possible distance between the cables, especially where cables are running in parallel over long distances.

If the PROFIBUS cable has to cross a motor and braking resistance cable, it should occur at a 90° angle.

Earth connection

It is important that all stations connected to the PROFIBUS network are connected to the same

earth potential. The earth connection must have a low HF (high frequency) impedance. This can be achieved by connecting a large surface area of the cabinet to earth, for example by mounting the FC motor on a conductive rear plate.

Especially when having long distances between the stations in a PROFIBUS network it can be necessary to use additional potential equalizing cables, connecting the individual stations to the same earth potential.

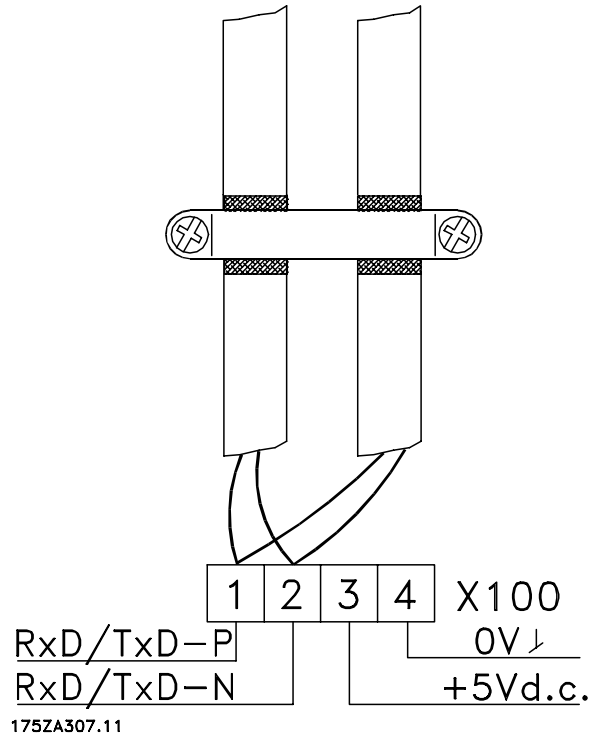

The bus termination - FCM 300

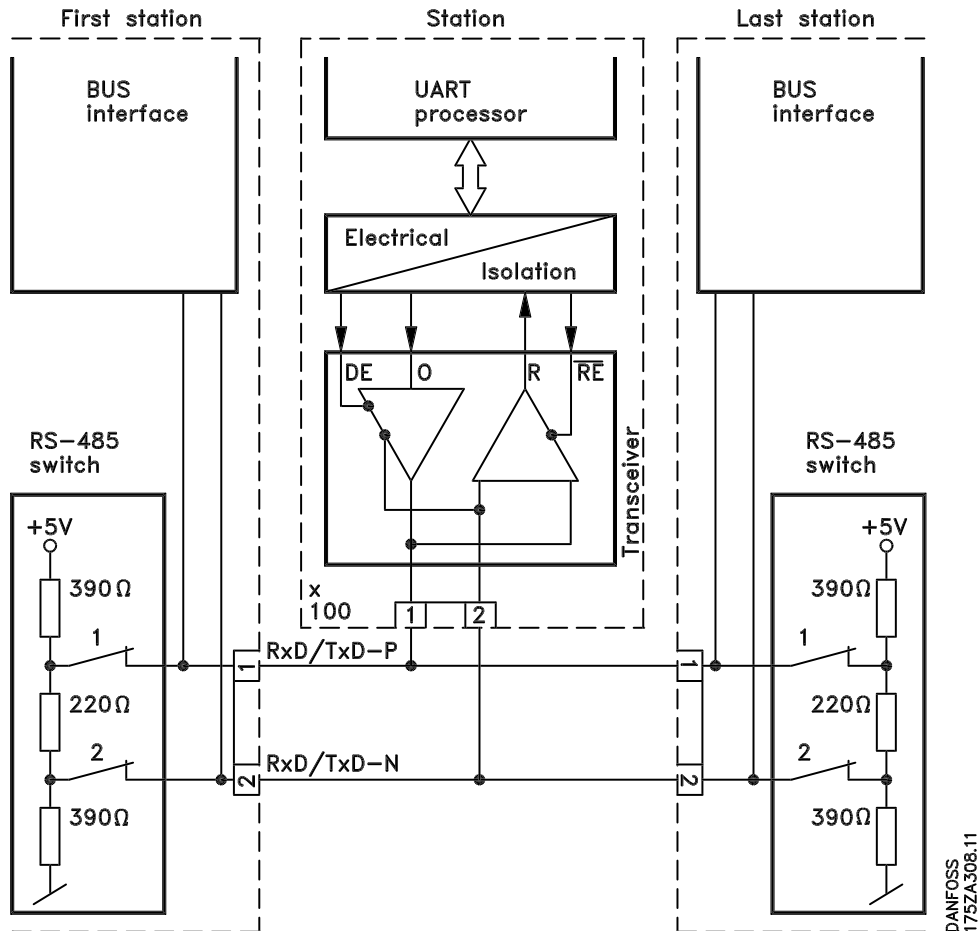

1 = RxD/TxD-P~ (red cable)

2 = RxD/TxD-N~ (green cable)

It is essential that the bus line is terminated properly. A mismatch of impedance may result in reflections on the line that will corrupt data transmission.

- The PROFIBUS is provided with a suitable termination which may be activated by the switches of the RS485 switch block located just to the left of the terminal block X100 (see drawing below). The switches should be on to terminate the bus.



NB!:

The switches should never be left in opposite positions. They should either both be ON or both be OFF!

- Most masters and repeaters are equipped with their own termination.
- If an external termination circuit consisting of three resistors is connected to the bus line a 5 V d.c. power supply must be used, please note that this must be galvanically isolated from the a.c. line.

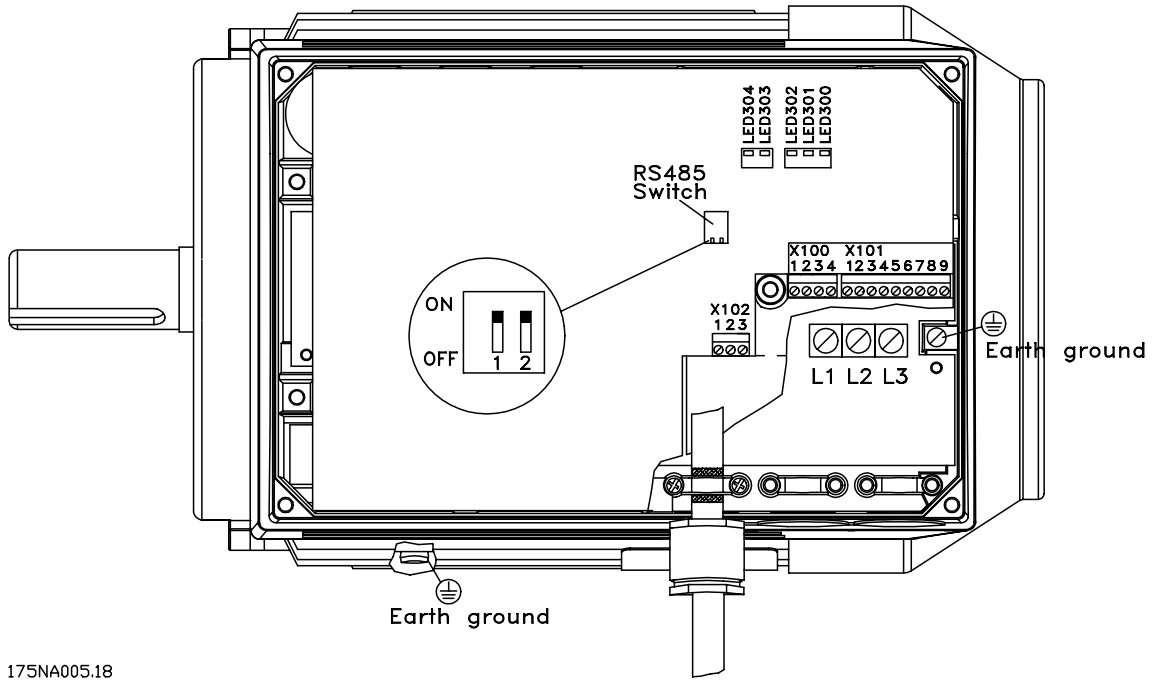

175NA005.18

■ **FCM 300 LEDs**

There are 2 LEDs on the PROFIBUS:

LED303: Lights up when the card is initialized and ready to communicate. It will flash while auto baudrate detection is attempting to detect the actual baudrate.

LED304: Lights up when the card is communicating, depending on baudrate.



NB!:

A high baudrate results in dim light in LED304.

Physical connection FCD 300

The PROFIBUS is connected to the bus line via, terminals 68 and 69.

It is recommended to use a master with a galvanic isolated bus driver and with over voltage protection (e.g. zenerdiode).

EMC precautions

The following EMC precautions are recommended to obtain interference free operation of the PROFIBUS network. Additional information on EMC can be found in the design guide on the FCD 300 (MG.04.AX.02). Please also consult the manual of the PROFIBUS master for further installation guidelines.

Connection of the cable screen

The screen of the PROFIBUS cable must always be connected to ground at both ends, that means the screen must be connected to ground in all stations connected to the PROFIBUS network. It is very important to have a low impedance ground connection of the screen, also at high frequencies. This can be obtained by connecting the surface of the screen to ground, for example by means of a cable clamp.

The FCD 300 Series is provided with a spring loaded clamp to enable a proper ground connection of the PROFIBUS cable screen. The screen connection is shown in the following drawing.



NB!:

Relevant national and local regulations, for example regarding protective earth connection, must be observed.

Cable connection FCD 300

The PROFIBUS communication cable must be kept away from motor and brake resistor cables to avoid coupling of high frequency noise from one cable to the other. Normally a distance of 200 mm is sufficient, but it is generally recommended to keep the greatest possible distance between the cables, especially where cables are running in parallel over long distances.

If the PROFIBUS cable has to cross a motor and braking resistance cable, it should occur at a 90° angle.

Earth connection FCD 300

It is important that all stations connected to the PROFIBUS network are connected to the same earth potential. The earth connection must have a low HF (high frequency) impedance.

Especially when having long distances between the stations in a PROFIBUS network it can be necessary to use additional potential equalizing cables, connecting the individual stations to the same earth potential.

Connecting the bus line

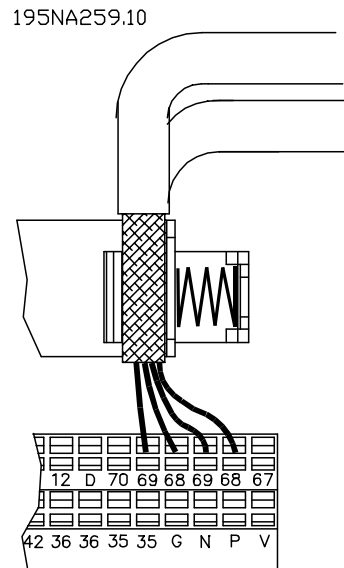

The bus termination

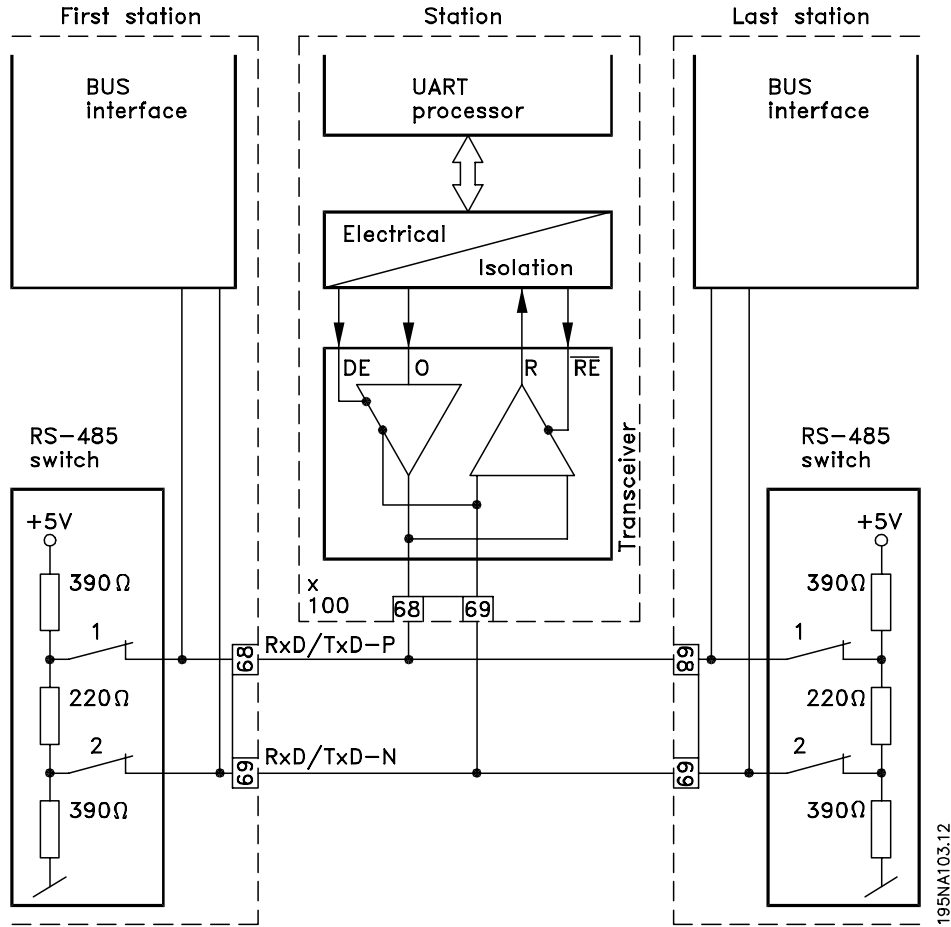

68 = RxD/TxD-P~ (red cable)

69 = RxD/TxD-N~ (green cable)

It is essential that the bus line be terminated properly. A mismatch of impedance may result in reflections on the line that will corrupt data transmission.

- The PROFIBUS is provided with a suitable termination which may be activated by the switches of the RS485 switch block located on the bottom of the electronics part (see drawing below). The switches should be on to terminate the bus.
- Most masters and repeaters are equipped with their own termination.

- If an external termination circuit consisting of three resistors is connected to the bus line a 5 V d.c. power supply must be used, please note that this must be galvanically isolated from the a.c. line.



NB!:

The switches should never be left in opposite positions. They should either both be ON or both be OFF!



NB!:

Is 126 or 127 selected the address is setting via P918, refer to chapter station address.

FCM 300 / FCD 300 / VLT® 2800 / DP V1 PROFIBUS

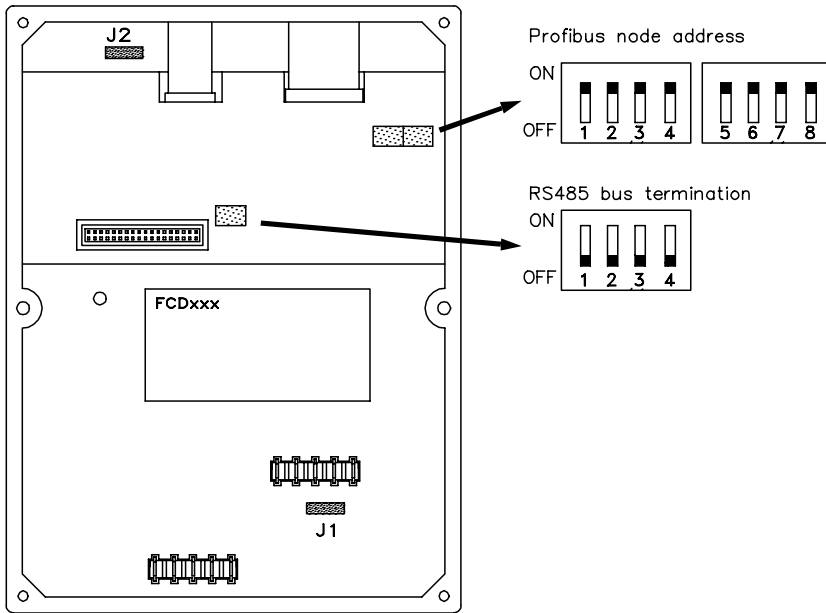

195NA260.12

Switch	1	2	3	4	5	6	7	8
Address	Switch setting							
0	OFF	OFF	OFF	OFF	OFF	OFF	OFF	X
1	ON	OFF	OFF	OFF	OFF	OFF	OFF	X
2	OFF	ON	OFF	OFF	OFF	OFF	OFF	X
...125	ON	ON	ON	ON	ON	OFF	ON	X
126	ON	ON	ON	ON	ON	ON	OFF	X
127 (default)	ON	ON	ON	ON	ON	ON	ON	X

■ FCD 300 LEDs

The bus LED on the front:		
	LCP stop mode or Operation site = local	Remote and bus control
Baud rate search	LED is flashing	LED is flashing
Baud rate found and drive is ready to get and set cyclical data	Flashing 1.5 sec.	On
Baud rate found and drive is not set to state receive/send cyclical data	Flashing 1.5 sec.	Flashing: 2 sec. off, 320 ms on
Only acyclical communication (no cyclical data)	Flashing 1.5 sec.	Flashing: 2 sec. off, 320 ms on

In case that a cyclical communication is established, the LED is on. If only a acyclical communication with a master 2 is active the LED is flashing.

■ Physical connection VLT 2800

The PROFIBUS is connected to the bus line via, terminals 68 and 69.

It is recommended to use a master with a galvanic isolated bus driver and with over voltage protection (e.g. zenerdiode).

EMC precautions

The following EMC precautions are recommended to obtain interference free operation of the PROFIBUS network. Additional information on EMC can be found in the design guide on the VLT 2800 (MG.28.EX.02). Please also consult the manual of the PROFIBUS master for further installation guidelines.

a low HF (high frequency) impedance. This can be achieved by connecting a large surface area of the cabinet to earth, for example by mounting the VLT 2800 on a conductive rear plate.

Especially when having long distances between the stations in a PROFIBUS network it can be necessary to use additional potential equalizing cables, connecting the individual stations to the same earth potential.

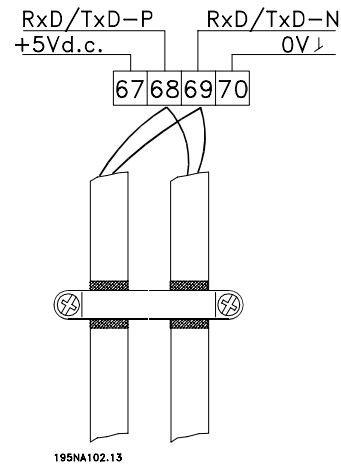

■ Connection of the cable screen

The screen of the PROFIBUS cable must always be connected to ground at both ends, that means the screen must be connected to ground in all stations connected to the PROFIBUS network. It is very important to have a low impedance ground connection of the screen, also at high frequencies. This can be obtained by connecting the surface of the screen to ground, for example by means of a cable clamp.

The VLT 2800 Series is provided with different clamps to enable a proper ground connection of the PROFIBUS cable screen. The screen connection is shown in the following drawing.



NB!:

Relevant national and local regulations, for example regarding protective earth connection, must be observed.

■ Cable connection VLT 2800

The PROFIBUS communication cable must be kept away from motor and brake resistor cables to avoid coupling of high frequency noise from one cable to the other. Normally a distance of 200 mm is sufficient, but it is generally recommended to keep the greatest possible distance between the cables, especially where cables are running in parallel over long distances.

If the PROFIBUS cable has to cross a motor and braking resistance cable, it should occur at a 90° angle.

■ Earth connection

It is important that all stations connected to the PROFIBUS network are connected to the same earth potential. The earth connection must have

The bus termination

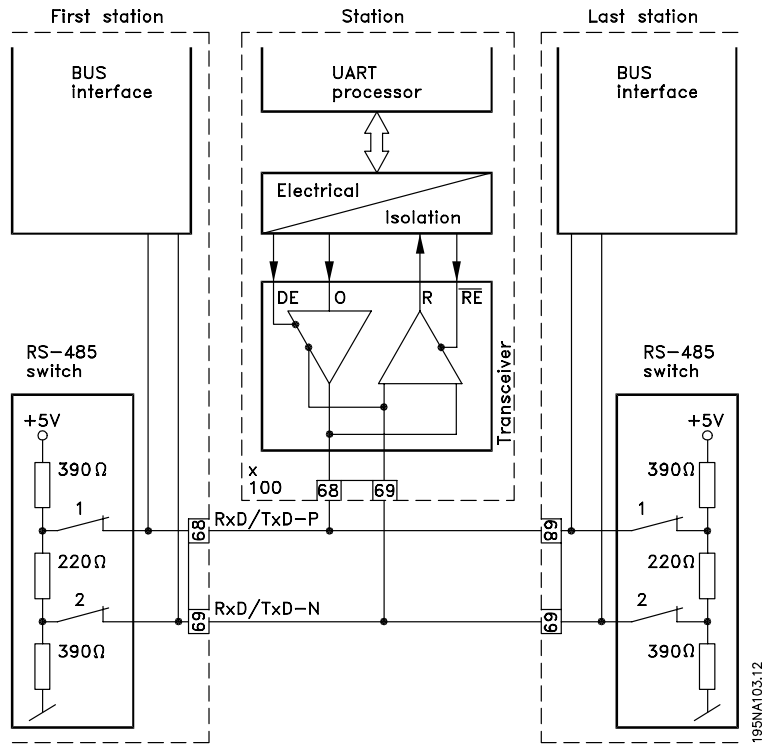

68 = RxD/TxD-P~ (red cable)

69 = RxD/TxD-N~ (green cable)

It is essential that the bus line be terminated properly. A mismatch of impedance may result in reflections on the line that will corrupt data transmission.

- The PROFIBUS is provided with a suitable termination which may be activated by the switches of the RS485 switch block located just above the

terminal block 67-70 (see drawing below). The switches 1 and 2 should be on to terminate the bus.

- Most masters and repeaters are equipped with their own termination.
- If an external termination circuit consisting of three resistors is connected to the bus line a 5 V d.c. power supply must be used, please note that this must be galvanically isolated from the a.c. line.

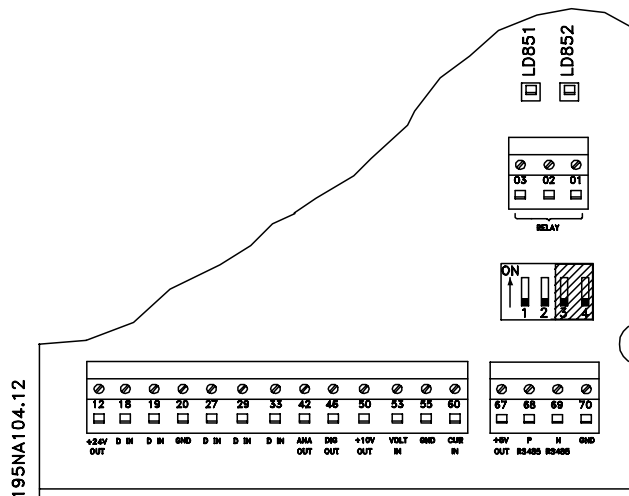

■ VLT 2800 LEDs

There are 2 LEDs on the PROFIBUS:

LD851:

Lights up when the card is initialized and ready to communicate. It will flash while auto baudrate detection is attempting to detect the actual baudrate.

LD852:

Lights up when the card is communicating, depending on baudrate.



NB!:

A high baudrate results in dim light in LD852.

Profibus DP

■ DP communication relations

Communication according to PROFIBUS DP, i.e. EN 50170 part 3, is supported. Consequently a master that supports PROFIBUS DP must be used.

By DP communication one of the parameter-process data objects (PPO's) described below must be used.

■ PPO description

A special feature of the PROFIBUS Profile for frequency converters is the communication object called a PPO, meaning *Parameter-Process Data Object*.

The PPO is well suited for fast cyclical data transfer, and may, as the name implies, carry both process data and parameters.

The selection of PPO type is made according to the master configuration.

A PPO may consist of a parameter part and process data part. The parameter part can be used for reading and/or updating the parameters one by one. The process data part consists of a fixed part (4 bytes) and a parametrable part (8 or 16 bytes). In the fixed part control word and speed reference are transferred to the frequency converter while status word and actual output frequency feedback are transferred from the frequency converter. In the parametrable part the user chooses which parameters have to be transferred to (parameter 915) and which from (parameter 916) the frequency converter.

PPO. Parameter-Process Data Object

By DP one of the following shown PPO's must be used:

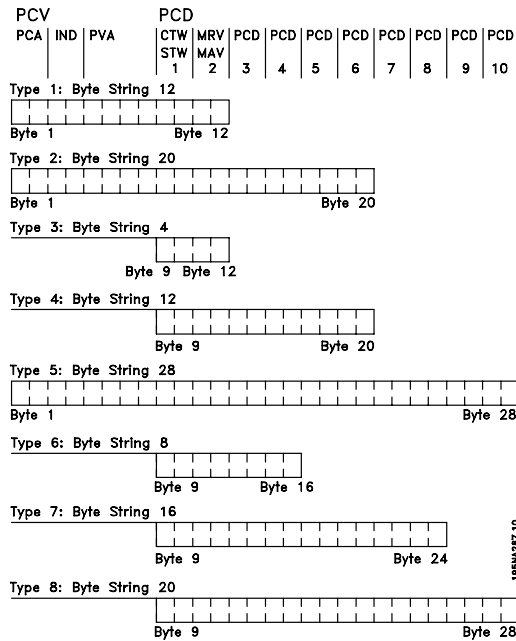

- PCD: Process Data
- PCV: Parameter-Characteristics-Value
- PCA: Parameter-Characteristics (Bytes 1, 2)
(PCA handling see section *PCA handling*)
- IND: Subindex (Byte 3), (Byte 4 is not used)
- PVA: Parameter value (Bytes 5 to 8)
- CTW: Control word see section *Control word*
- STW: Status word see section *Status word*
- MRV: Main reference value
- MAV: Main actual value (Actual output frequency)

■ PCA handling

The PCA portion of the PPO types 1, 2 and 5 will handle a number of tasks. The master may control and supervise parameters and request a response from the slave, while the slave, apart from responding to a request from the master may transmit a spontaneous message.

Requests and responses is a handshake procedure and cannot be batched, meaning that if the master sends out a **Read/write** request, it has to wait for the response, before it sends a new request. The request or response data value will be limited to max. 4 bytes, which implies that text strings are not transferable. For further information, please see section **Examples** .

PCA - Parameters Characteristics

15	14	13	12	11	10	9	8	7	6	5	4	3	2	1	0
RC				SMP	PNU										

RC: Request /response Characteristics (Range 0..15)
 SMP: Toggle-Bit for Spontaneous Messages
 PNU: Parameter # (Range 1..1999)

Request/response handling

The RC portion of the PCA word defines the requests that may be issued from the master to the slave as well as what other portions of the PCV (IND and PVA) are involved.

The PVA portion will transmit word-size parameter values in bytes 7 and 8, while long word size values require bytes 5 to 8 (32 bits).

If the Response / Request contains array elements, the IND will carry the Array Subindex. If parameter descriptions are involved, the IND will hold the Record Subindex of the Parameter description.

RC content

Request	Function
0	No request
1	Request parameter value
2	Change parameter value (word)
3	Change parameter value (long word)
4	Request description element
5	Change description element
6	Request parameter value (array)
7	Change parameter value (array word)
8	Change parameter value (array long word)
9	Request number of array elements
10-15	Not used

Re- sponse	Function
0	No response
1	Transfer parameter value (word)
2	Transfer parameter value (long word)
3	Transfer description element
4	Transfer parameter value (array word)
5	Transfer parameter value (array long word)
6	Transfer number of array elements
7	Request rejected (incl. fault #, see below)
8	Not serviceable by PCV interface
9	Spontaneous message (word)
10	Spontaneous message (long word)
11	Spontaneous message (array word)
12	Spontaneous message (array long word)
13-15	Not used

If the slave rejects a request from the master, the RC word in the PPO-read will indicate this by assuming the value 7. The fault # will be carried by bytes 7 and 8 in the PVA element.

Fault #	Interpretation
0	Illegal PNU
1	Parameter value cannot be changed
2	Upper or lower limit exceeded
3	Subindex corrupted
4	No array
5	Data type false
6	Cannot be set by user (reset only)
7	Description element cannot be changed
8	IR required PPO-write not available
9	Description data not available
10	Access group
11	No parameter write access
12	Key word missing
13	Text in cyclical transmission not readable
14	Name in cyclical transmission not readable
15	Text array not available
16	PPO-write missing
17	Request temporarily rejected
18	Other fault
19	Date in cyclical transmission not readable
130	There is no bus access to the parameter called
131	Data change is not possible because factory Setup has been selected

■ Parameter and data type structure description

Parameter description

DP has a number of describing attributes (see right).

Read/write on parameter description is made by the PCV part using the RC commands 4/5 and subindex of the desired description element.

Size attribute

The size index and the conversion index for each parameter can be taken from the parameter list in the respective Operating Instructions.

Physical unit	Size index	Measuring unit	Designation	Conversion index	Conversion factor
	0	No dimension			
		second	s	0	1
				-1	0.1
				-2	0.01
Time	4	millisecond	ms	-3	0.001
		minute	min	70	60
		hour	h	74	3600
		day	d	77	86400
		watthour	Wh	0	1
Energy	8	kilowatthour	kWh	3	1000
		megawatthour	MWh	6	10 ⁶
		milliwatt	mW	-3	0.001
Power	9	watt	W	0	1
		kilowatt	kW	3	1000
		megawatt	MW	6	10 ⁶
Rotation	11	rotation per minute	RPM	0	1
		newtonmeter	Nm	0	1
Torque	16	kilonewtonmeter	kNm	3	1000
Temperature	17	degree Celsius	°C	0	1
		millivolt	mV	-3	0.001
Voltage	21	volt	V	0	1
		kilivolt	kV	3	1000
		milliampere	mA	-3	0.001
Current	22	ampere	A	0	1
		kiloampere	kA	3	1000
		milliohm	mOhm	-3	0.001
Resistance	23	ohm	Ohm	0	1
		kiloohm	kOhm	3	1000
Ratio	24	per cent	%	0	1
Relative change	27	per cent	%	0	1
		hertz	Hz	0	1
Frequency	28	kilohertz	kHz	3	1000
		megahertz	MHz	6	10 ⁶
		gigahertz	GHz	9	10 ⁹

■ Object and data types supported by FCM 300, FCD 300 and VLT 2800

Data types supported by FCM 300, FCD 300 and VLT 2800

Data type	Object code	Short name	Description
3	5	12	Integer 16
5	5		Unsigned 8
6	5	O2	Unsigned 16
7	5	O4	Unsigned 32
10	5		Byte string
13	5		Time difference ¹⁾
33	5	N2	Standardized value (16 bit) ¹⁾
35	5	V2	Bit sequence ¹⁾

¹⁾ See elaboration below

Time difference

The data type time difference is a time indication in milliseconds.

Notation: Time difference
 Value range: $0 \leq i \leq (2^{32} - 1)$ milliseconds
 Coding: The time is presented as a binary value of 32 bits (4 bytes). The first four (MSB) bits are always zero.
 Time difference is thus a byte string of 4 bytes.

Data coding of the data type time difference

Bit	Byte 1	Byte 2	Byte 3	Byte 4	
8	0 ms	2^{23} ms	2^{15} ms	2^7 ms	MSB
7	0 ms	2^{22} ms	2^{14} ms	2^6 ms	MSB
6	0 ms	2^{21} ms	2^{13} ms	2^5 ms	MSB
5	0 ms	2^{20} ms	2^{12} ms	2^4 ms	MSB
4	2^{27} ms	2^{19} ms	2^{11} ms	2^3 ms	
3	2^{26} ms	2^{18} ms	2^{10} ms	2^2 ms	
2	2^{25} ms	2^{17} ms	2^9 ms	2^1 ms	
1	2^{24} ms	2^{16} ms	2^8 ms	2^0 ms	

Standardized value

A binary value.

0% = 0 (0h), 100% is 2^{14} (4000h)

Data type	N 2
Range	-200%...200% -2^{-14}
Resolution	$2^{-14} = 0.0061\%$
Length	2 bytes

Notation: 2's complement notation.

MSB is 1st bit after sign bit in 1st byte.

Sign bit = 0 = positive number

Sign bit = 1 = negative number

Bit	8	7	6	5	4	3	2	1
Byte 1	SIGN	2^0	2^{-1}	2^{-2}	2^{-3}	2^{-4}	2^{-5}	2^{-6}
Byte 2	2^{-7}	2^{-8}	2^{-9}	2^{-10}	2^{-11}	2^{-12}	2^{-13}	2^{-14}

Bit sequence

16 boolean values for control and presentation of user functions.

Notation is binary

Bit	8	7	6	5	4	3	2	1
Byte 1	15	14	13	12	11	10	9	8
Byte 2	7	6	5	4	3	2	1	0

■ Spontaneous messages

The Spontaneous message is activated by the active parameters i.e. 538, 540, or 953 and will be carried with the PCV response, stating PNU and PVA of the changed active parameter that triggered the message.

Spontaneous messages are generated when the value is changed in one of the abovementioned parameters. It means that a message will be sent when a warning comes, and when a warning disappears.

Simultaneously the frequency converter will toggle the SPM bit (11) of PCA word (see section **PCA handling**).

The Spontaneous messages will be transmitted until the master has acknowledged reception of the message by changing the SPM bit.



NB!:

Spontaneous messages are only active when parameter 917 is "ON"!

Example of SPM execution

In the frequency converter the SPMs are temporarily stored in a FIFO buffer. This means that up to 16 consecutive SPMs can be retained. If only one SPM has entered the FIFO, the frequency converter will resume normal communication as soon as the SPM has been acknowledged by the master (and the condition causing the SPM been rectified). If more SPMs are in the FIFO, these will be transmitted consecutively upon acknowledgement. If more SPMs are triggered when the FIFO is full, these will be ignored.

■ Synchronize and freeze

The control commands SYNC/UNSYNC and FREEZE/UNFREEZE are broadcast functions. SYNC/UNSYNC is used to send synchronized control commands and/or speed reference to all the connected slaves (FCM 300/FCD 300/VLT 2800 Series). FREEZE/UNFREEZE is used to freeze the status feedback in the slaves to get synchronized feedback from all connected slaves.

The synchronize and freeze commands only affect Process Data (the PCD part of the PPO).

SYNC/UNSYNC can be used to obtain simultaneous reactions in several slaves, for example synchronised start, stop or speed change. A SYNC command will freeze the actual control word and speed reference, incoming Process Data will be stored but not used until a new SYNC command or a UNSYNC command is received.

See the example below where the left column holds the speed reference send out by the master and the three right columns hold the actual speed reference used in each of the three slaves.

SYNC/UNSYNC

	Actual slave speed reference		
	VLT Address 3	VLT Address 4	VLT Address 5
From DP master to address:			
1. Speed reference = 50% to address 3	50%	0%	0%
2. Speed reference = 50% to address 4	50%	50%	0%
3. Speed reference = 50% to address 5	50%	50%	50%
4. SYNC command to all addresses	50%	50%	50%
5. Speed reference = 75% to address 3	50%	50%	50%
6. Speed reference = 75% to address 4	50%	50%	50%
7. Speed reference = 75% to address 5	50%	50%	50%
8. SYNC command to all addresses	75%	75%	75%
9. Speed reference = 100% to address 3	75%	75%	75%
10. Speed reference = 50% to address 4	75%	75%	75%
11. Speed reference = 25% to address 5	75%	75%	75%
12. UNSYNC command to all addresses	100%	50%	25%
13. Speed reference = 0% to address 3	0%	50%	25%
14. Speed reference = 0% to address 4	0%	0%	25%
15. Speed reference = 0% to address 5	0%	0%	0%

FREEZE/UNFREEZE

FREEZE/UNFREEZE can be used to get simultaneous reading of Process Data for example output current from several slaves. A FREEZE command will freeze the current actual values and on request the slave will send back the value that was present when the FREEZE command was received. The actual

values will be updated when a new FREEZE or UNFREEZE command is received.

See the example below where the left column holds the current values read by the master and the three right columns hold the actual output current of the three slaves.

	Actual slave output current		
	VLT Address 3	VLT Address 4	VLT Address 5
DP master reads address:			
1. Address 3 output current = 2 A	← 2 A	3 A	4 A
2. Address 4 output current = 5 A	2 A	← 5 A	2 A
3. Address 5 output current = 3 A	3 A	2 A	← 3 A
4. FREEZE command to all addresses	1 A	3 A	3 A
5. Address 3 output current = 1 A	← 4 A	2 A	5 A
6. Address 4 output current = 3 A	2 A	← 2 A	2 A
7. Address 5 output current = 3 A	3 A	1 A	← 2 A
8. UNFREEZE command to all addresses	2 A	3 A	4 A

Reading as by 1, 2 and 3

■ Clear Mode / Fail Safe

If the PLC/Master functions are seriously disturbed, the DP master will go into Clear Mode. The Drive can be programmed to react in various ways on that incident. These options are shown in the table below.

The drives which support the DP V1 features, basically support the Fail Safe function for Clear Mode as stated in the GSD attribute Fail_safe = 1. Fail Safe means, that the slaves safely detect a clear state of the master. The reaction however must be programmed as shown in the table below.

For masters, that do not support Fails Safe Clear, the drive will have the same reaction on a clear mode as for Fail Safe Clear.

If a Clear appears, the control word and speed reference is set to zero in the drive. The reaction of the drive, however depends on the setting of parameter 805 (control word validity) and parameter 804 (Time Out function).

P804	P805	Drive Behaviour on Clear mode
Off	Bit 10 = 1, Control Word valid	The drive will continue with the previous send valid Control word and speed reference
Off	Bit 10 = 0, Control Word valid	The Drive Control Word and Speed Reference will be set to zero, which will cause the drive to stop.
Off	No function: Control Word always valid	The Drive Control Word and Speed Reference will be set to zero, which will cause the drive to stop.
<>Off	Bit 10 = 1, Control Word valid	The drive will continue with the previous send valid Control word and speed reference until the timer programmed in P 803 expires. After that the drive will do the action programmed in P 804.

The drive leaves the Clear Reaction State when the master sends process data values <> 0.

NB!:

The behaviour, which is described in the first line is the factory setting. In critical applications a time out function can be used. In case of clear mode, the drive is working as described in the selection of parameter 805.

■ **Control word/Status word**

The bits of the "Control word" tell the frequency converter how to react, while the "Status word" bit status will tell the master the condition of the frequency converter.

Control word

The control words are used to send control commands to the frequency converter when the telegram is sent from the master.

Control word		
According to PROFIDRIVE control word (par. 512 = 0)		
Bit	Bit = 0	Bit = 1
00 (LSB)	OFF 1	ON 1
01	OFF 2	ON 2
02	OFF 3	ON 3
03	Motor coasting	Enable
04	Quick-stop	Ramp
05	Freeze output frequency	Ramp enable
06	Ramp stop	Start
07	No function	Reset
08	Jog 1 OFF	ON
09	Jog 2 OFF	ON
10	Data not valid	Valid
11	No function	Slow down
12	No function	Catch-up
13	Setup select LSB	
14	Setup select MSB	
15 (MSB)	No function	Reversing

Control word		
According to FC Control Word (par. 512 = 1)		
Bit	Bit = 0	Bit = 1
00 (LSB)	Preset reference LSB	
01	Preset reference MSB	
02	DC brake	Ramp
03	Coasting	Enable
04	Quick-stop	Ramp
05	Freeze output	Ramp enable
06	Ramp stop	Start
07	No function	Reset
08	No function	Jog
09	Ramp 1	Ramp 2
10	Data not valid	Valid
11		Relay 01 active ¹⁾
12		DO46 ²⁾
13	Setup select LSB	
14	Setup select MSB	
15 (MSB)	No function	Reversing

¹⁾ FCM digital output

²⁾ No function for FCM 300.

The FCM 300 Design Guide (MG.03.BX.02), the FCD 300 Design Guide (MG.04.AX.02) and the VLT 2800 Series Design Guide (MG.28.EX.02) hold a detailed description of the control word.

■ **Status word**

When the frequency converter returns the frame to the master, the same two bytes operate as status from the frequency converter with the following functions:

Status word		
According to PROFIDRIVE control word (par. 512 = 0)		
Bit	Bit = 0	Bit = 1
00 (LSB)	Control not ready	Ready
01	VLT not ready	Ready
02	Motor coasting	Enable
03	No fault	Trip
04	ON 2	OFF 2
05	ON 3	OFF 3
06	Stop enable	Start disable
07	No warning	Warning
08	Speed ≠ ref.	Speed = ref.
09	Local operation	Bus control
10	Out of range	Frequency OK
11	Not running	Running
12		
13	Voltage OK	Limit
14	Torque OK	Limit
15 (MSB)	No thermal warning	Thermal warning

Status word		
According to FC Control Word (par. 512 = 1)		
Bit	Bit = 0	Bit = 1
00 (LSB)	Control not ready	Ready
01	VLT not ready	Ready
02	Coasting	Enable
03	No fault	Trip
04	R e s e r v e d	
05	R e s e r v e d	
06	No trip lock	Trip lock
07	No warning	Warning
08	Speed ≠ ref.	Speed = ref.
09	Local operation	Bus control
10	Out of range	Frequency OK
11	Not running	Running
12		
13	Voltage OK	Above limit
14	Current OK	Above limit
15 (MSB)	No thermal warning	Thermal warning

The FCM 300 Design Guide (MG.03.BX.02), the FCD 300 Design Guide (MG.04.AX.02) and the VLT

2800 Series Design Guide (MG.28.EX.02) hold a detailed description of the control word.

■ **Example**

This example shows how PPO type 1 is used for changing the ramp-up time (parameter 207) to 10 seconds and for commanding a start and speed reference of 50%.

Frequency converter parameter settings:
 P502: serial port
 P512: Fieldbus profile (Profidrive profile)

PPO. Parameter-Process Data Object

PCD: Process Data
 PCV: Parameter-Characteristics-Value
 PCA: Parameter-Characteristics (Bytes 1, 2) PCA handling below
 IND: Subindex (Byte 3), (Byte 4 is not used)
 PVA: Parameter value (Bytes 5 to 8)
 CTW: Control word see section *Control word*
 STW: Status word see section *Status word*
 MRV: Main reference value
 MAV: Main actual value

PCV

PCA - Parameters Characteristics

15	14	13	12	11	10	9	8	7	6	5	4	3	2	1	0
RC				SMP	PNU										

RC: Request /respons Characteristics (Range 0..15)
 SPM: Toggle-Bit for Spontaneous Messages
 PNU: Parameter # (Range 1..1999)

PCA part (byte 1-2) The RC part tells what the PCV part must be used for. The functions available appear from the table, see section *PCA handling*.

When a parameter is to be changed, choose value 2 or 3, in this example 3 is chosen, because parameter 207 covers a long word (32 bits).

SPM bit:

The function is explained in section *Spontaneous messages*, in the example the function Spontaneous Messages is not applied (parameter 917 = OFF), therefore SPM is set for 0. PNU = Parameter number: Parameter number is set for: 207 = CF Hex. This means that the value of the PCA part is 30CF Hex.

IND (bytes 3-4):

Used when reading/changing parameters with subindex, for example parameter 915. In the example bytes 3 and 4 are set to 00 Hex.

PVA (bytes 5-8):

The data value of parameter 207 must be changed to 10.00 seconds. The value transmitted must be 1000, because the conversion index for parameter 207 is -2, this means that the value received by the frequency converter is divided by 100, making the frequency converter perceive 1000 as 10.00. Bytes 5-8 = 1000 = 03E8 Hex.

PCD

CTW according to Profidrive profile:

Control words consisting of 16 bits, the meaning of the various bits appears from the table, see section *Control word/Status word*. The following bit pattern sets all necessary start commands:

0000 0100 0111 1111 = 047F Hex.*
 0000 0100 0111 1110 = 047E Hex.*
 0000 0100 0111 1111 = 047F Hex.
 Quickstop: 0000 0100 0110 1111 = 046F Hex.
 Stop: 0000 0100 0011 1111 = 043F Hex.
 * For restart after power up: Trip OFF 2 and 3.

MRV:

Speed reference, the data format is "Standardized value". 0 Hex = 0% and 4000 Hex = 100%.

In the example 2000 Hex is used corresponding to 50% of maximum frequency (parameter 202).

The whole PPO therefore gets the following value in Hex:

		Byte	Value	
		PCA	1	30
		PCA	2	CF
		IND	3	00
		IND	4	00
PCV	PVA	5	00	
	PVA	6	00	
	PVA	7	03	
	PVA	8	E8	
		CTW	9	04
		CTW	10	7F
PCD	MRV	11	20	
	MRV	12	00	

The Process data within the PCD part is acting on the frequency converter immediately, and can be updated from the master as quickly as possible.

The PCV part is a "hand shake" procedure which means that the frequency converter has to acknowledge the command, before a new one can be written.

- A positive response of the above example may look like this:

		Byte	Value
PCV	PCA	1	20
	PCA	2	CF
	IND	3	00
	IND	4	00
	PVA	5	00
	PVA	6	00
	PVA	7	03
	PVA	8	E8
PCD	STW	9	0F
	STW	10	07
	MAV	11	20
	MAV	12	00

		Byte	Value
PCV	PCA	1	70
	PCA	2	00
	IND	3	00
	IND	4	00
	PVA	5	00
	PVA	6	00
	PVA	7	00
	PVA	8	02
PCD	STW	9	0F
	STW	10	07
	MAV	11	20
	MAV	12	00

RC is 7 Hex which means that the request has been rejected, and the fault number can be found in the PVA part. In this case the fault number is 2 which means that the upper or lower limit of the parameter is exceeded. See fault number table in section **PCA handling**.

The PCD part responds according to the state and parametrization of the frequency converter.

The PCV part responds as: PCA: As the request telegram, but here the RC part is taken from the response table see section **PCA handling**. In this example RC is 2Hex, which is a confirmation that a parameter value of the type long word (32 bit) has been transferred.

IND is not used in this example.

PVA: 03E8Hex in the PVA part tells that the value of the parameter in question (207) is 1000 which corresponds to 10.00.

STW: 0F07 Hex means that the motor is running and there are no warnings or faults (for details see Status word table in section **Status word**).

MAV: 2000 Hex tells that the output frequency is 50% of max. frequency.

- A negative response may look like this:

■ DP V1 Identifications

The V1 functionalities require a GSD file supporting V1. Of compatibility reasons in general the V1 versions got the same DP ident number as the corresponding V0 version. This means, that a V1 unit

can replace a V0 unit without changing the master configuration. The table shows the available GSD files for FCM 300/FCD300/VLT 2800.

GSD files are placed on <http://www.danfoss.com/drives>.

GSD File Name FCM 300	Description	Ident nr.	GSD revision
DA010403.GSD	FCM 300 V0 3 Mbaud (old version)	0403H	01
DA020403.GSD	FCM 300 V0 3 Mbaud (actual version)	0403H	02
DA010408.GSD	FCM 300 V0 12 Mbaud (old version)	0408H	01
DA020408.GSD	FCM 300 V0 12 Mbaud (actual version)	0408H	02

GSD File Name FCD 300	Description	Ident nr.	GSD revision
DA010406.GSD	FCD 300 V0 3 Mbaud (old version)	0406H	01
DA010407.GSD	FCD 300 V0 12 Mbaud (old version)	0407H	01
DA020406.GSD	FCD 300 V0 3 Mbaud (actual version)	0406H	02
DA020407.GSD	FCD 300 V0 12 Mbaud (actual version)	0407H	02
DA030406.GSD	FCD 300 V1 3 Mbaud (actual version)	0406H	03
DA030407.GSD	FCD 300 V1 12 Mbaud (actual version)	0407H	03

GSD File Name VLT 2800	Description	Ident nr.	GSD revision
DA010404.GSD	VLT 2800 V0 3 Mbaud (old version)	0404H	01
DA010405.GSD	VLT 2800 V0 12 Mbaud (old version)	0405H	01
DA020404.GSD	VLT 2800 V0 3 Mbaud (actual version)	0404H	02
DA020405.GSD	VLT 2800 V0 12 Mbaud (actual version)	0405H	02
DA030405.GSD	VLT 2800 V1 12 Mbaud (actual version)	0405H	03
DA030404.GSD	VLT 2800 V1 3 Mbaud (actual version)	0404H	03

■ FCM 300, FCD 300, VLT 2800 parameters

Only the PROFIBUS specific parameters (800 - 805 and 904 . . .) are described in this manual. All other parameters and their functions are unaffected by the PROFIBUS option. We refer to the parameter description in the design guide on the FCM 300 Series (MG.03.Bx.02), the design guide on the FCD 300 (MG.04.Ax.02) and the design guide on the VLT 2800 Series (MG.28.EX.02). Please note, that some parameters might not be active in all products.

Special attention must be given to the following parameters that are not described in this manual:

- 502- 508: Selection of how to gate PROFIBUS control commands with control commands on the digital inputs of the FCM 300/FCD 300/VLT2800.
- 512: Control word profile, selects a control word according to profidrive or a Danfoss specified control word.
- 515 - 543: Data readout parameters that can be used to read various actual data from the frequency converter, as for example actual status on the analog and digital inputs of the FCM 300/FCD 300/VLT 2800 thus using these as inputs to the master.

■ PROFIBUS specific parameters

800 Protocol select (PROTOCOL SELECT)

Value:

★PROFIBUS DP V1 [30]

Function:

Selection of the PROFIBUS protocol supported by the master.

Description of choice:

DP: Communication according to EN 50170, part 3



NB!:

In the event of an update of parameter 800, even with an unchanged data value, the PROFIBUS option is initialized, which means that all communication parameters 801, 802, ..., e.g. slave address, baud rate, PPO type etc., are being updated.

803 Bus time out (BUS TIME OUT)

Value:

1 - 99 sec. ★ 1 sec.

804 Bus time out function (TIME OUT FUNCT.)

Value:

★Off (OFF)	[0]
Freeze output frequency (FREEZE OUTPUT)	[1]
Stop with auto restart (STOP)	[2]
Output frequency = JOG freq. (JOGGING)	[3]
Output freq. = Max. freq. (MAX SPEED)	[4]
Stop with trip (STOP AND TRIP)	[5]
No comm. option control (NO COMM OPT CONTROL)	[6]
Select setup 4 (SELECT SET UP 4)	[7]
Select setup 2	[8]

Function:

The time out counter is triggered at the first reception of a valid control word i.e. bit 10 = ok, when DP is used.

The **time out** function can be activated in two different ways:

1. CTW is not updated within the time specified in parameter 803.
2. Time out is triggered if the CTW is not valid, see parameter 805.

The FCM 300/FCD 300/VLT 2800 remains in time out state until one of the following conditions is true:

1. Valid control word (Bit 10 = ok) is received. If Stop with trip is selected, reset must also be activated. If

Select setup 2 is selected, the FCM 300/FCD 300 / VLT 2800 will remain in Setup 2 until parameter 4 is changed.

2. Parameter 804 = Off P control via PROFIBUS is resumed and the most recent control word is used.

Description of choice:

- **Freeze output frequency:** Freeze output frequency until communication is resumed.
- **Stop with auto restart:** Stop with auto restart when communication is resumed.
- **Output frequency = JOG freq.:** Motor will run at JOG frequency until communication is resumed.
- **Output frequency = Max. freq.:** Motor will run at max. frequency until communication is resumed.
- **Stop with trip:** Motor is stopped, reset needed for restart, see explanation above.
- No communication option control: enable the process control via the serial port or digital input.
- Select setup 4
- Select setup 2.

805 Function of control word bit 10 (BIT 10 FUNCTION)

Value:

No function (NO FUNCTION)	[0]
★Bit 10 = 1 CTW active (BIT 10 = 1 CTW ACTIVE)	[1]
Bit 10 = 0 CTW active (BIT 10 = 0 CTW ACTIVE)	[2]
Bit 10 = 0 time out (BIT 10 = 0 TIME OUT)	[3]

Function:

Control word and speed reference will be ignored if bit 10 of the control word is 0, but parameter 805 lets the user change the function of bit 10. This is some times necessary as some masters are setting all bits to 0 in various fault situations. In these cases it makes sense to change the function of bit 10 so that the FCM 300/FCD 300/VLT 2800 is commanded to stop (coast) when all bits are 0.

Description of choice:

- **Bit 10 = 1 CTW active:** Control word and speed reference is ignored if bit 10 = 0.
- **Bit 10 = 0 CTW active:** Control word and speed reference is ignored if bit 10 = 1. If all bits of the control word are 0 the FCM 300/FCD 300/ VLT 2800 reaction will be coasting.
- **Bit 10 = 0 time out:** The time out function selected in parameter 804 is activated when bit 10 is 0.
- **No function:** Bit 10 is ignored, i.e. control word and speed reference is always valid.

825 Delayed speed change delay

(SPEED CNG. DELAY)

Value:

20 - 10000 (20 ms-10 s) ★ 500

Function:

The delay will under certain conditions (see parameter 826) perform a fixed delay before a speed change will be activated.

Description of choice:

Select the wanted delay time.

The status of the timer can be read:

Timer expired: Parameter 528 Bit 7

Timer active: Parameter 528 Bit 8

826 Application control word

(APPL.CTRL.WORD)

Value:

Bus
 Bit Bit = 0 Bit = 1
 0 No function
 1 No function Delayed speed change

Function:

The function will perform a precise timing of a speed change. The speed change can also be to set speed = 0.

Description of choice:

Setting the ACW bit 1 to 1 will freeze any following change of the set speed until following conditions are fulfilled:

- Delayed speed change input (sensor) changed from 1 to 0
- Delayed speed change delay time is expired

Delayed speed change input:

FCM300 terminal 5, parameter 335 set to (Delayed speed change) (23) FCD300/VLT 2800 terminal 33, parameter 307 set to (Delayed speed change) (26)

The ACW bit 1 must be reset and set before the next delayed speed change can be initiated.

833 Fieldbus enabled

(FIELD BUS ENABLED)

Value:

Disable (DISABLE) [0]
 ★Enable (ENABLE) [1]

Function:

This function allows to disable the communication interface.

Description of choice:

If *Disable* [0] is selected no communication warning will appear, since the communication interface is disabled. Select *Enable* [1] to activate the communication.



NB!:

Please note that a change in this parameter will not be executed until the next power up has been carried through.

849 Extend Diagnosis

(EXTEND DIAGNOSIS)

Value:

★Disable (DISABLE)	[0]
Alarms (ALARMS)	[1]
Alarm and Warnings (ALARM AND WARNINGS)	[2]

Function:

This function allows to expand the diagnosis data to 24 Byte, if this parameter is set to *Alarm* [1] and *Alarm and Warning* [2].

Description of choice:

Please refer to the section *Extend diagnosis* in this manual.

904 PPO type select for DP

(PPO TYPE SELECT)

Value:

★PPO type 1 (PPO TYPE 1)	[900]
PPO type 2 (PPO TYPE 2)	[901]
PPO type 3 (PPO TYPE 3)	[902]
PPO type 4 (PPO TYPE 4)	[903]
PPO type 5 (PPO TYPE 5)	[905]
PPO type 6 (PPO TYPE 6)	[906]
PPO type 7 (PPO TYPE 7)	[907]
PPO type 8 (PPO TYPE 8)	[908]

Function:

Read out of PPO type set by the master.

Description of choice:

- PPO type 1: 12 byte PPO with parameter channel for read and write of parameters and 4 bytes of process data (control/status word and reference/actual output frequency).
- PPO type 2: 20 byte PPO as PPO type 1 with 8 additional bytes of selectable process data.
- PPO type 3: 4 byte process data (control/status word and reference/actual output frequency).
- PPO type 4: 12 byte process data, as process data part of PPO type 2.
- PPO type 5: 28 byte as PPO type 2 with 8 additional bytes of selectable process data.
- PPO type 6: control/status word and reference/actual output frequency and additional 4 byte process data.
- PPO type 7: control/status word and reference/actual output frequency and additional 12 byte process data.
- PPO type 8: control/status word and reference/actual output frequency and additional 16 byte process data.

A detailed description of the PPO types can be found in section *PPO description*.

915 PCD config. write

(PCD IN WR-)

Value:

Sub index 1 (PCD 3)	[Parameter #]
Sub index 2	[Parameter #]
Sub index 3	[Parameter #]
Sub index 4	[Parameter #]
Sub index 5	[Parameter #]
Sub index 6	[Parameter #]
Sub index 7	[Parameter #]
Sub index 8	[Parameter #]

Function:

Different parameters may be assigned to the PCD 3-10 of the PPOs (the max.number of the PCD depends on the PPO type). The values in PCD 3-10 are written to the selected parameters in form of data values.

Write access to parameter 915 via Profibus or standard RS 485 or LCP2.

Description of choice:

The sequence of the sub-indexes corresponds to the sequence of the PCD in the PPO, i.e. sub-index 1 = PCD 3, sub-index 2 = PCD 4 etc. Each sub-index may contain the number of any frequency converter parameter that can be written to. Each PCD is defined as a word. If data should be written to a parameter that has an attribute of Integer 32 or Unsigned 32 the parameter number should be defined twice in the following PCD's: PCD 3 and 4, PCD 5 and 6, PCD 7 and 8 or PCD 9 and 10. See example by parameter 916 *PCD config. Read*.



NB!:

First the odd subindex must be written. Otherwise the data will be interpreted as 2 low words.

916 PCD config. read

(PCD IN RD-)

Value:

Sub index 1 (PCD 3)	[Parameter #]
Sub index 2	[Parameter #]
Sub index 3	[Parameter #]
Sub index 4	[Parameter #]
Sub index 5	[Parameter #]
Sub index 6	[Parameter #]
Sub index 7	[Parameter #]
Sub index 8	[Parameter #]

Function:

Different parameters may be assigned to the PCD 3-10 of the PPOs (the max.number of the PCD depends on the PPO type). The values in PCD 3-10 are read from the selected parameters in form of data values.

Write access to parameter 916 via Profibus or standard RS 485 or LCP2.

Description of choice:

The sequence of the sub-indexes corresponds to the sequence of the PCD in the PPO, i.e. sub-index 1 = PCD 3, sub-index 2 = PCD 4 etc. Each sub-index may contain the number of any VLT parameter.

Each PCD is defined as a word. If data should be read from a parameter that has an attribute of Integer 32 or Unsigned 32 the parameter should be defined twice in the following PCD's: PCD 3 and 4, PCD 5 and 6, PCD 7 and 8 or PCD 9 and 10.



NB!:

The odd subindex must be written first. Otherwise the data will be interpreted as 2 low words.1

Example PPO type 6:

PCD 1	CTW/STW	
PCD 2	MRV/MAV	
PCD 3	Par 515	
PCD 4	Par 518	
PCD 5	Par 520	High word
PCD 6	Par 520	Low word
PCD 7	Par 538	High word
PCD 8	Par 538	Low word

CTW/STW = Control word / Status word = 16 bit
 MRV/MAV = Main Reference Value / Main Actual Value = 16 bit
 Par 515 Data readout: Reference % = Datatype 3=>Integer 16
 Par 518 data readout: Frequency = Datatype 3 => Integer 16
 Par 520 Data readout= Motor current =Datatype 7 =>Unsigned 32
 Par 538 Data readout: Alarm Word = Datatype 7 => Unsigned 32

917 Active spontaneous messages (SPONT. MES)

Value:
 ★Off (OFF) [0]
 On (ON) [1]

Function:
 The spontaneous messages function can be switched on if it is desired to make the FCM 300/FCD 300/VLT 2800 issue a message when a warning or an alarm comes up.



NB!:

Unread spontaneous messages will be stored in a 16 elements FIFO buffer.

Description of choice:

- **OFF:** The FCM 300/FCD 300/VLT 2800 will not issue spontaneous messages or event notification in case of a warning or an alarm.

- **ON:** The FCM 300/FCD 300/VLT 2800 will issue a spontaneous message when warnings or alarms are coming up.

918 Station address (STATION ADDR)

Value:
 0-125
 ★126

Function:
 All stations connected to the same bus must have a unique address. The station address can be set in parameter 918.



NB!:

A change in parameter 918 is executed at next power up or if parameter 800 is updated. Please see section Station address in this manual for further information.

927 PCV Operating authority (PARAMETER EDIT)

Value:
 Disable (DISABLE) [0]
 ★Enable (ENABLE) [1]

Function:
 The parameter channel PCV can be blocked meaning that the modification of parameters through this channel is not possible. Access through standard RS 485 interface is still possible.

Description of choice:

If **Disable** [0] is selected, parameter processing through Profibus is not active. If **Enable** [1] is selected, parameter processing through Profibus is active.

928 Control authority (PROCESS CONTROL)

Value:
 Disable (DISABLE) [0]
 ★Enable (ENABLE) [1]

Function:

The process control (adjustment of control word, speed reference value and of the following variable PCD) can be blocked. Control through the control card terminals

Parameters

FCM 300 / FCD 300 / VLT® 2800 / DP V1 PROFIBUS

is still possible via the terminals, depending on how the parameters 502-508 have been programmed.

953 Warning parameter 1

(WARN. PARA)

Value:

Read only

Function:

In this parameter it is possible to read out warning messages via standard bus or Profibus. This parameter is not available via LCP, but the warning message can be seen by choosing Com warning word as display readout. A bit is assigned to every warning (see the following list).

Bit	Bit = "1" when:
0	LSB Connection with DP-master is not ok
1	Not used
2	FDL (Field-bus Data link Layer) is not ok
3	Clear data command received
4	Actual value is not updated
5	Spontaneous message FIFO overflow
6	PROFIBUS ASIC is not transmitting
7	Initialising of PROFIBUS option is not ok
8	Not used
9	Not used
10	Not used
11	Not used
12	Fatal DPR-handling error/Error code during init.: Bit 0
13	Fatal DPR-handling error/Error code during init.: Bit 1
14	Fatal DPR-handling error/Error code during init.: Bit 2
15	MSB Fatal DPR-handling error/Error code during init.: Bit 3

Explanation of error codes:

Depending of Bit 7 the corresponding error codes can be seen from Bit 12-15.

Bit 7 = 1: Initialisation failure

Code	
0	OK
1	Init. channel not empty
2	No resp. on command "Init. SPC3 controller"
3	No resp. on command "No action"
4	No resp. on writing init.-data
5	No valid resp. on writing init.-data
6	No positive resp. on writing init.-data

Bit 7 = 0: Run time failure

Code

0	OK
1	Fatal error in warning channel
2	Fatal error in spontaneous channel
3	Fatal error in channel for input of process data
4	Fatal error in channel for output of process data
5	Fatal error in parameter channel 1
6	Fatal error in parameter channel 2
7	Fatal error in parameter channel 3
15	Fatal error in DPR form SPC3

964 Identification

Value:

- 0 Manufacturer
- 1 Device type
- 2 Version
- 3 Firmware date year
- 4 Firmware date month
- 5 Number of axes
- 6 Profibus version
- 7 Database Version
- 8 Power unit ID
- 9 BMC software ID (P632)

Function:

This parameter contains the identification of a Profibus slave. This parameter is read only and only accessible via the Profibus V1 communication.

965 Profile Number

(PROFILE NUMBER)

Value:

- Profile number 1. octet Manufacturer [3]
- Profile number 2. octet [3]

Function:

This parameter contains the profile number which a Profibus slave supports. This parameter is read only and only accessible via the Profibus V1 communication.

967 Control word

Value:

16 bits binary code

Function:

This parameter is read only and only accessible via the Profibus communication.

968 Status word

Value:

Read only

Function:

This parameter is read only and only accessible via the Profibus communication.

970 Edit set up selection

(EDIT SETUP SELECT)

Value:

Factory setup (FACTORY SETUP)	[0]
Setup 1 (SETUP 1)	[1]
Setup 2 (SETUP 2)	[2]
Setup 3 (SETUP 3)	[3]
Setup 4 (SETUP 4)	[4]
★Active setup (ACTIVE SETUP)	[5]

Function:



NB!:

FCM Setyp only 1 and 2!

This parameter is to be used for accessing drives parameters in various setups from a master class 1 (eg. PLC), please refer to the section *Read/Write on frequency converter parameters*.

971 Store data values

(STORE DATA VALUE)

Value:

★No action (NO ACTION)	[0]
Store active setup (STORE ACTIVE SETUP)	[1]
Store edit setup (STORE EDIT SETUP)	[2]
Store all setups (STORE ALL SETUPS)	[3]

Function:

Parameter values changed via profibus is only stored in ram meaning that the changes are lost at power down. This parameter is used to activate a function

that stores all parameter values in the EEPROM thus retaining changed parameter values at power down.

Description of choice:

No action: The store function is inactive.

Store active setup: All parameter values in the active setup will be stored in the EEPROM. The value returns to **No action** when all parameter values have been stored.

Store edit setup (p. 970): All parameter values in the setup you are editing will be stored in the EEPROM. The value returns to **No action** when all parameter values have been stored.

Store all setups: All parameter values in both setups will be stored in the EEPROM. The value returns to **No action** when all parameter values have been stored.

980-982 Defined parameters

(DEFINED PNU'S)

Value:

Read only

Function:

The three parameters hold a list of all the parameters that are defined in the FCM 300/FCD 300/VLT 2800. It is possible to read single elements of the list by DP by using the corresponding subindex. The subindexes start at 1 and follow the order of the parameter numbers.

Each parameter holds up to 116 elements (parameter numbers).

When a 0 is returned as parameter number the list ends.

990-992 Modified parameters

(MODIFIED PNU'S)

Value:

Read only

Function:

The three parameters hold a list of all the FCM 300/FCD 300/VLT 2800 parameters that have been changed from factory setting. It is possible to read single elements of the list by DP by using the corresponding subindex. The subindexes start at 1 and follow the order of the parameter numbers. Each parameter holds up to 116 elements (parameter numbers). The number of parameters (990, 991 and 992) in use depends on how many parameters have been changed from factory setting.

Read only parameters, as for example data read out parameters, will not be registered as modified even though they are changing.

When a 0 is returned as parameter number the list ends.

■ Read/write on frequency converter parameters

In an automation system, frequency converter parameters can be accessed either from the Process controller (i.e. PLC), or by various kinds of HMI equipment. In order not to interfere access from controllers and tools, the following should be taken into consideration: Parameter access in the drive is performed in two logical parameter channels, which can be individually programmed to access a certain parameter setup via parameters 005 Programming Setup and 970 Parameter setup selection. This means, that before writing or reading to a parameter in a certain frequency converter set-up from a PLC, the parameter 970 must be set to the desired set-up. For access from HMI equipment, the access is controlled by parameter 005. The figure below shows this behaviour, and the possible sources of the two logical parameter channels.

VLT frequency converter

Access from process control e.g. PLC:

- PCV channel (DP V0)
- MSAC Master Class 1

Access from HMI:

- Local Control Panel
- FC standard interface
- MSAC Master class 2

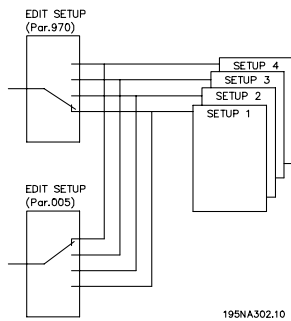

Please note, that even though these two logical parameter channels are separated, data conflict can occur, if write on parameters is made from a HMI unit into a set-up which is actively used by the frequency converter or used by the process controller (e.g. PLC).



NB!:

For backward compatibility reasons the following behaviour must be observed:

A Read or Write on parameter 970 via the MSAC master class 2 connection will be accepted, but the value will internally be read /written to parameter 005.

A Read or Write on parameter 005 via the process controller channel will be accepted, but the value will internally be read/written to parameter 970.

For parameter store, the following should be observed:

A Write command to a frequency converter parameter via the MSAC Master class 2 connection will be stored in RAM and in Non Volatile Memory. Please note, that continuous writing to frequency converter parameters via the MSAC Master class 2 connection should be avoided in order not to damage the Non Volatile Memory.

A Write command to a frequency converter parameter via the Process Control channel will be stored in RAM only. Store in Non Volatile Memory is possible by writing a store command to parameter 971 Save data values, which will result in store of the entire set-up in NVRAM.

The table below shows how data write from various sources are stored in the frequency converter:

Data source	RAM	NVRAM
PCV channel (DP V0)	Yes	Store set-up by parameter 971
MSAC Master Class 1	Yes	Store set-up by parameter 971
Local Control Panel	Yes	Yes
MCT 10 software via FC interface	Yes	Yes
MCT 10 software via MSAC 2	Yes	Yes
FC standard interface	Yes	Yes, by specific Write command
MSAC Master Class 2	Yes	Yes

■ **Warning and alarm messages**

There is a clear distinction between alarms and warnings. In the case of an alarm, the FCM 300/FCD 300/VLT 2800 will enter a fault condition. After the cause for the alarm has been cleared, the master will have to acknowledge the alarm message for the FCM 300/FCD 300/VLT 2800 to start operating again. A warning, on the other hand may come when a warning condition appears, and disappear when conditions return to normal without interfering with the process.

Warnings

Any warning within the FCM 300/FCD 300/VLT 2800 is represented by a single bit within a warning word. A warning word is always an active parameter. Bit status FALSE [0] means no warning, while bit status TRUE [1] means warning.

Any bit change in the warning word will result in a Spontaneous message being issued.

In addition to the warning word message the master will also be notified through a change of bit 7 in the Status Word.

Alarms

Following an Alarm message the FCM 300/FCD 300/VLT 2800 will enter Fault condition. Only after the fault has been alleviated and the master has acknowledged the alarm message by setting bit 7 in the Control word, can the FCM 300/FCD 300/VLT 2800 resume operation.

Any alarm within the FCM 300/FCD 300/VLT 2800 is represented by a single bit within an alarm word. An alarm word is always an action parameter. Bit status FALSE [0] means no fault, while bit status TRUE [1] means fault.

Any bit change in the alarm word will result in a Spontaneous message being issued.

■ **Spontaneous messages**

If a fault or warning condition should occur, the FCM 300/FCD 300/VLT 2800 will, if the proper communicative relationship has been established, issue a Spontaneous message to communication partners. Instead of responding to the master's request, the FCM 300/FCD 300/VLT 2800 will exchange the requested response with the alarm or the warning message.

Warnings and alarms will trigger a Spontaneous message. The same is true with any change to an active parameter.

■ **Warning word, extended Status word and Alarm word**

Warning word, extended status word and alarm word are shown on the display in Hex format. If there are more than one warning or alarm, a sum of all warnings or alarms will be shown. Warning word, extended status word and alarm word can also be displayed using the serial bus in parameter 540, 541 and 538.

Bit (Hex)	Alarm word (p. 538)
00000002	Trip lock
00000004	AMT tuning fail
00000040	HPFB timeout
00000080	Standard bus timeout
00000100	Short circuit
00000200	24 V supply fault
00000400	Earthe fault
00000800	Overcurrent
00002000	Motor thermistor
00004000	Motor overload
00008000	Inverter overload
00010000	Undervoltage
00020000	Overvoltage
00040000	Phase loss
00800000	Live zero error
01000000	Heat sink temperature too high
02000000	Profibus communication fault
08000000	Inrush fault
10000000	Internal fault

Bit (Hex)	Alarm word (p. 540)
00000008	HPFB timeout
00000010	Standard bus timeout
00000040	Current limit
00000080	Motor thermistor
00000100	Motor overload
00000200	Inverter overload
00000400	Undervolt
00000800	Overvolt
00001000	Voltage warning low
00002000	Voltage warning high
00004000	Phase loss
00010000	Live zero error warning
00400000	Out of frequency range
00800000	Profibus communication fault
40000000	Switch mode warning
80000000	Heat sink temperature high

Warnings and alarm messages

Bit (Hex)	Unit diagnose bit	Alarm word (p. 541)
00000001	80	Ramping
00000002	81	Automatic motor tuning
00000004	82	Start clockwise/anti- clockwise
00000008	83	Slow down
00000010	84	Catch-up
00000020	85	Feedback high
00000040	86	Feedback low
00000080	87	Output current high
00000100	72	Output current low
00000200	73	Output frequency high
00000400	74	Output frequency low
00000800	75	Brake test ok
00001000	76	Braking max.
00002000	77	Braking
00004000	78	Quick discharge ok
00008000	79	Out of frequency range
00010000	64	Not used
00020000	65	Not used
00040000	66	Not used
00080000	67	Not used
00100000	68	Not used
00200000	69	Not used
00400000	70	Not used
00800000	71	Not used
01000000	56	Not used
02000000	57	Not used
04000000	58	Not used
08000000	59	Not used
10000000	60	PB acyclic MG1 communication
20000000	61	PB acyclic MG1 communication
40000000	62	Not used
80000000	63	Not used

Bit (Hex)	Alarm word (p. 953)
00000001	Connection with DP-master is not ok
00000002	Not used
00000004	FDL (Field-bus Data Link Layer) is not ok
00000008	Clear data command received
00000010	Actual value is not updated
00000020	Spontaneous message FIFO overflow
00000040	PROFIBUS ASIC is not transmitting
00000080	Initialising of PROFIBUS option is not ok
00000100	Not used
00000200	Not used
00000400	Not used
00000800	Not used
00001000	Not used
00002000	Not used
00004000	Not used
00008000	Not used

■ Station address

The station address of slave can be selected via

- Hardware switch (only FCD 300)
- Parameter 918 via bus or LCP2
- Command "Set Station Address" of Profibus DP

The address via the hardware switch is valid, if the switch is set between 0-125. All selections via parameter 918 or "Set Station Address" command will be rejected. The address setting will only be effective at power up. Changing during run time will be effective at next power up.

The setting of address via parameter 918 is possible, if the hardware switch is set to 126 or 127 (factory setting). A new address is effective at a new power up.

The setting of the address via the "Set Station Address" command is possible, if the hardware switch is set to 126 or 127 (factory setting). By the "Set Station Address" command it is possible to lock the programmed address, which makes it impossible to change the address by this command. The address setting will be unlocked, if the parameter 918 or the address switch is changed followed by a power cycle.

■ Extended Diagnosis

By the extended diagnose function it is possible to receive alarm and warning information from the

The extended diagnose frame has the following content:

Byte	Content	Description
0 through 5	Standard DP Diagnose data	Standard DP Diagnose frame
6	Pdu length xx	Header of Extended diagnostic data
7	Status type = 0x81	Header of Extended diagnostic data
8	Slot = 0	Header of Extended diagnostic data
9	Status infor = 0	Header of Extended diagnostic data
10 through 13	VLT parameter 540	VLT warning word
14 through 17	VLT parameter 541	VLT status word
18 through 21	VLT parameter 538	VLT Alarm word
22 through 23	VLT parameter 953	Communication warning word

frequency converter. The setting of parameter 849 determines which frequency converter events should trigger the extended diagnose function.

If parameter 849 is set to Disable [0], no extended diagnose data is sent regardless whether they appear in the frequency converter. If parameter 849 is set to Alarms [1], extended diagnose data is sent, if one or more alarms arrive in the Alarm parameters 538 or 953. If parameter 849 is set to Alarms/Warnings [2], extended diagnose data is sent if one or more alarms/warnings arrive in the Alarm parameters 538 or 953 or the warning parameter 540.

The sequence of an extended diagnose is as follows: If an Alarm or warning appears, the frequency converter will indicate that to the master by sending a high prior message via the output data telegram. This will cause the master to ask the frequency converter for extended diagnose information, which will be replied by the frequency converter. When the Alarm/warning disappears, the frequency converter will again indicate that to the master, and on the following request from the master, return a standard DP diagnose frame (6 bytes).

■ Abbreviations

English	German	Elaboration
ACI	-	Acyclical Control Interval
ALI	-	Application Layer Interface
ATTR	-	Attribute
BRCT	-	Broadcast
CCI	-	Cyclical Control Interval
CR	KR	Communication Reference
CRL	KBL	Communication Reference List
CSRD	-	Cyclical Send and Request Data
CT	Typ	Connection Type
CTW	STW	Control Word
DA	-	Destination Address
DP	-	Distributed Periphery
EIA	-	Electronic Industries Association: Specifiers of the EIA Standard RS 485-A
EMC	EMV	Electromagnetic Compatibility
EN	-	Event Notification
FIFO	-	First In First Out
HSA	-	Highest Station Address
Hd	-	Hamming distance
HPFB	-	High Performance Field Bus
IND	-	Subindex
I/O	E/A	Input/Output
ISO	-	International Standards Organization
IR	-	Information Report
LSAP	-	Local Service Access Point
LSB	-	Least Significant Bit
MSB	-	Most Significant Bit
MAP	-	Manufacturing Automation Protocol
MAV	HIW	Main Actual Value
MMS	-	Manufacturing Message Specification
MRV	HSW	Main Reference Value
MSAC	MZAC	Master-Slave connection for acyclical transmission
MSAC SI	MZAC SI	Master-Slave connection for acyclical transmission with slave initiative
MSCY	MSZY	Master-Slave connection for cyclical transmission
MSCY SI	MSZY SI	Master-Slave connection for cyclical transmission with slave initiative
MULT	-	Multicast
OD	OV	Object Directory
PC	-	Personal Computer
PCA	PKE	Parameter Characteristics
PCD	PZD	Process Data
PCV	PKW	Parameter-Characteristics-Value
PDU	-	Protocol Data Unit
PLC	SPS	Programmable Logic Control
PNU	-	Parameter Number
PPO	-	Parameter-Process Data Object
PVA	PWE	Parameter Value
RAC	-	Receive Acknowledged request Counter
RADR	-	Remote Address
RC	AK	Request/Response Characteristics
RCC	-	Receive Confirmed request Counter
RSAP	-	Remote Service Access Point
SAC	-	Send Acknowledged request Counter
SAP	-	Service Access Point
SCC	-	Send Confirmed request Counter
SPM	-	Spontaneous Notification
STW	ZSW	Status Word
TRT	-	Target Rotation Time
VDE	-	Association of German Electrical Technicians
VDI	-	Association of German Electrical Engineers

■ Parameter list with factory settings

PNU #	Parameter description	Factory setting	4-setup	Conv. index	Data type
001	Language	English	No	0	5
002	Local/remote operation	Remote-controlled	Yes	0	5
003	Local reference	000,000.000	Yes	-3	4
004	Active Setup	Setup 1	No	0	5
005	Programming Setup	Active Setup	No	0	5
006	Setup copying	No copying	No	0	5
007	LCP copy	No copying	No	0	5
008	Display scaling	1.00	Yes	-2	6
009	Large display readout	Frequency [Hz]	Yes	0	5
010	Small display line 1.1	Reference [%]	Yes	0	5
011	Small display line 1.2	Motor current [A]	Yes	0	5
012	Small display line 1.3	Power [kW]	Yes	0	5
013	Local control	Remote control as par. 100	Yes	0	5
014	Local stop/reset	Active	Yes	0	5
015	Local jog	Not active	Yes	0	5
016	Local reversing	Not active	Yes	0	5
017	Local reset of trip	Active	Yes	0	5
018	Data change lock	Not locked	Yes	0	5
019	Operating status at power up	Forced stop, use saved ref.	Yes	0	5
020	Lock for Hand mode	Active	No	0	5
024	User-defined Quick Menu	Not active	No	0	5
025	Quick Menu Setup	000	No	0	6

4-Setup:

'Yes' means that the parameter can be programmed individually in each of the four Setups, i.e. one single parameter can have four different data values. 'No' means that the data value will be the same in all Setups.

Conversion index:

This number refers to a conversion figure to be used when writing or reading via serial communication with a frequency converter.

See **Data character** in **Serial communication** in the **Design Guide**.

Data type:

Data type shows the type and length of the telegram.

Data type	Description
3	Integer 16
4	Integer 32
5	Unsigned 8
6	Unsigned 16
7	Unsigned 32
9	Text string

FCM 300 / FCD 300 / VLT® 2800 / DP V1 PROFIBUS

PNU #	Parameter-description	Factory setting	4-setup	Conv. index	Data-type
100	Configuration	Speed reg., open loop	Yes	0	5
101	Torque characteristics	Constant torque	Yes	0	5
102	Motor power $P_{M,N}$	depends on unit	Yes	1	6
103	Motor voltage $U_{M,N}$	depends on unit	Yes	-2	6
104	Motor frequency $f_{M,N}$	50 Hz	Yes	-1	6
105	Motor current $I_{M,N}$	depends on motor selected	Yes	-2	7
106	Rated motor speed	depends on par. 102	Yes	0	6
107	Automatic motor adjustment	Optimisation off	Yes	0	5
108	Stator resistance R_S	depends on motor selected	Yes	-3	7
109	Stator reactance X_S	depends on motor selected	Yes	-2	7
117	Resonance damping	OFF	Yes	0	6
119	High start torque	0.0 sec	Yes	-1	5
120	Start delay	0.0 sec	Yes	-1	5
121	Start function	Coast in start del.	Yes	0	5
122	Function at stop	Coast	Yes	0	5
123	Min. freq. for activation of par. 122	0.1 Hz	Yes	-1	5
126	DC braking time	10 sec.	Yes	-1	6
127	DC brake engaging frequency	OFF	Yes	-1	6
128	Thermal motor protection	No protection	Yes	0	5
130	Start frequency	0.0 Hz	Yes	-1	5
131	Voltage at start	0.0 V	Yes	-1	6
132	DC brake voltage	0%	Yes	0	5
133	Start voltage	depends on unit	Yes	-2	6
134	Load compensation	100 %	Yes	-1	6
135	U/f-ratio	depends on unit	Yes	-2	6
136	Slip compensation	100 %	Yes	-1	3
137	DC hold voltage	0%	Yes	0	5
138	Brake cut out value	3.0 Hz	Yes	-1	6
139	Brake cut in frequency	3.0 Hz	Yes	-1	6
140	Current, minimum value	0%	Yes	0	5
142	Leak reactance	depends on motor selected	Yes	-3	7
143	Internal ventilator control	Automatic	Yes	0	5
144	AC brake factor	1.30	Yes	-2	5
146	Reset voltage vector	Off	Yes	0	5

FCM 300 / FCD 300 / VLT® 2800 / DP V1 PROFIBUS

PNU #	Parameter description	Factory setting	4-setup	Conv. index	Data type
200	Output frequency range	Clockwise only, 0-132 Hz	Yes	0	5
201	Output frequency, low limit f_{MIN}	0.0 Hz	Yes	-1	6
202	Output frequency, high limit f_{MAX}	132 Hz	Yes	-1	6
203	Reference range	Min ref.-Max ref.	Yes	0	5
204	Minimum ref Ref_{MIN}	0.000 Hz	Yes	-3	4
205	Maximum ref Ref_{MAX}	50.000 Hz	Yes	-3	4
206	Ramp type	Linear	Yes	0	5
207	Ramp-up time 1	3.00 sec.	Yes	-2	7
208	Ramp-down time 1	3.00 sec.	Yes	-2	7
209	Ramp-up time 2	3.00 sec.	Yes	-2	7
210	Ramp-down time 2	3.00 sec.	Yes	-2	7
211	Jog ramp time	3.00 sec.	Yes	-2	7
212	Quick stop ramp-down time	3.00 sec.	Yes	-2	7
213	Jog frequency	10.0 Hz	Yes	-1	6
214	Reference function	Sum	Yes	0	5
215	Preset reference 1	0.00%	Yes	-2	3
216	Preset reference 2	0.00%	Yes	-2	3
217	Preset reference 3	0.00%	Yes	-2	3
218	Preset reference 4	0.00%	Yes	-2	3
219	Catch up/slow down reference	0.00%	Yes	-2	6
221	Current limit	160 %	Yes	-1	6
223	Warn. Low current	0.0 A	Yes	-1	6
224	Warn. High current	I_{MAX}	Yes	-1	6
225	Warn. Low frequency	0.0 Hz	Yes	-1	6
226	Warn. High frequency	132.0 Hz	Yes	-1	6
227	Warn. Low Feedback	-4000.000	Yes	-3	4
228	Warn. High Feedback	4000.000	Yes	-3	4
229	Frequency bypass, bandwidth	0 Hz (OFF)	Yes	0	6
230	Frequency bypass 1	0.0 Hz	Yes	-1	6
231	Frequency bypass 2	0.0 Hz	Yes	-1	6

FCM 300 / FCD 300 / VLT® 2800 / DP V1 PROFIBUS

PNU #	Parameter description	Factory setting	4-setup	Conv. index	Data type
302	Digital input, term. 18	Start	Yes	0	5
303	Digital input, term. 19	Reversing	Yes	0	5
304	Digital input, term. 27	Reset and coast inverse	Yes	0	5
305	Digital input, term. 29	Jog	Yes	0	5
307	Digital input, term. 33	No function	Yes	0	5
308	Term. 53, analogue input voltage	Reference	Yes	0	5
309	Term. 53, min scaling	0.0 V	Yes	-1	6
310	Term. 53, max scaling	10.0 V	Yes	-1	6
314	Term. 60, analogue input current	No function	Yes	0	5
315	Term. 60, min scaling	0.0 mA	Yes	-4	6
316	Term. 60, max scaling	20.0 mA	Yes	-4	6
317	Time out	10 sec.	Yes	-1	5
318	Function after timeout	No function	Yes	0	5
319	Term. 42, analogue output	0-I _{MAX} = 0-20 mA	Yes	0	5
323	Relay output	Control ready	Yes	0	5
327	Pulse ref./FB	5000 Hz	Yes	0	7
341	Term. 46 digital output	Control ready	Yes	0	5
342	Term. 46 Max. pulse output	5000 Hz	Yes	0	6
343	Precise stop function	Normal ramp stop	Yes	0	5
344	Counter value	100000 pulses	Yes	0	7
349	Speed comp delay	10 ms	Yes	-3	6

4-Setup:

'Yes' means that the parameter can be programmed individually in each of the four Setups, i.e. one single parameter can have four different data values. 'No' means that the data value will be the same in all Setups.

Conversion index:

This number refers to a conversion figure to be used when writing or reading via serial communication with a frequency converter.

See **Data character** in **Serial communication** in the **Design Guide**.

Data type:

Data type shows the type and length of the telegram.

Data type	Description
3	Integer 16
4	Integer 32
5	Unsigned 8
6	Unsigned 16
7	Unsigned 32
9	Text string

FCM 300 / FCD 300 / VLT® 2800 / DP V1 PROFIBUS

PNU #	Parameter description	Factory setting	4-setup	Conv. index	Data type
400	Brake function	Depends on unit type	No	0	5
405	Reset function	Manual reset	Yes	0	5
406	Aut. restart time	5 sec.	Yes	0	5
409	Trip delay overcurrent	Off (61 sec.)	Yes	0	5
411	Switching frequency	4.5 kHz	Yes	0	6
412	Var. carrier frequency	No LC-filter	Yes	0	5
413	Overmodulation function	On	Yes	0	5
414	Min. feedback	0.000	Yes	-3	4
415	Max. feedback	1500.000	Yes	-3	4
416	Process units	No unit	Yes	0	5
417	Speed PID propor.ampl.	0.010	Yes	-3	6
418	Speed PID intergra.	100 ms	Yes	-5	7
419	Speed PID differentiation time	20.00 ms	Yes	-5	7
420	Speed PID diff. amplification limit	5.0	Yes	-1	6
421	Speed PID lowpass filter	20 ms	Yes	-3	6
423	U1 voltage	par. 103	Yes	-1	6
424	F1 frequency	Par. 104	Yes	-1	6
425	U2 voltage	par. 103	Yes	-1	6
426	F2 frequency	par. 104	Yes	-1	6
427	U3 voltage	par. 103	Yes	-1	6
428	F3 frequency	par. 104	Yes	-1	6
437	Proc. PID no/inv.	Normal	Yes	0	5
438	Proc. PID anti wind.	Active	Yes	0	5
439	Proc. PID start frequency	Par. 201	Yes	-1	6
440	Proc. PID start proportional ampl.	0.01	Yes	-2	6
441	Proc. PID integration time	Off (9999.99 s)	Yes	-2	7
442	Proc. PID differentiation time	Off (0.00 s).	Yes	-2	6
443	Proc. PID diff. ampl. limit	5.0	Yes	-1	6
444	Proc. PID lowpass filter time	0.02 s	Yes	-2	6
445	Flying start	Not possible	Yes	0	5
451	Speed PID feedforward factor	100%	Yes	0	6
452	Controller range	10 %	Yes	-1	6
456	Brake voltage reduce	0	Yes	0	5
461	Feedback conversion	Linear	Yes	0	5

FCM 300 / FCD 300 / VLT® 2800 / DP V1 PROFIBUS

PNU #	Parameter description	Factory setting	4-setup	Conv. index	Data type
500	Address	1	No	0	5
501	Baudrate	9600 Baud	No	0	5
502	Coasting stop	Logic or	Yes	0	5
503	Quick stop	Logic or	Yes	0	5
504	DC brake	Logic or	Yes	0	5
505	Start	Logic or	Yes	0	5
506	Reversing	Logic or	Yes	0	5
507	Selection of Setup	Logic or	Yes	0	5
508	Selection of preset ref.	Logic or	Yes	0	5
509	Bus jog 1	10.0 Hz	Yes	-1	6
510	Bus jog 2	10.0 Hz	Yes	-1	6
512	Telegram profile	FC protocol	Yes	0	5
513	Bus time interval	1 sec.	Yes	0	5
514	Bus time interval function	Off	Yes	0	5
515	Data readout: Reference %		No	-1	3
516	Data readout: Reference [unit]		No	-3	4
517	Data readout: Feedback [unit]		No	-3	4
518	Data readout: Frequency		No	-1	3
519	Data readout: Frequency x scaling		No	-1	3
520	Data readout: Motor current		No	-2	7
521	Data readout: Torque		No	-1	3
522	Data readout: Power [kW]		No	1	7
523	Data readout: Power [HP]		No	-2	7
524	Data readout: Motor voltage [V]		No	-1	6
525	Data readout: DC Link voltage		No	0	6
526	Data readout: Motor thermal load		No	0	5
527	Data readout: Inverter thermal load		No	0	5
528	Data readout: Digital input		No	0	5
529	Data readout: Analogue input, term. 53		No	-1	5
531	Data readout: Analogue input, term. 60		No	-4	5
532	Data readout: Pulse reference		No	-1	7
533	Data readout: External reference		No	-1	6
534	Data readout: Status word		No	0	6
535	Data readout: Bus feedback 1		No	0	3
537	Data readout: Inverter temperature		No	0	5
538	Data readout: Alarm word		No	0	7
539	Data readout: Control word		No	0	6
540	Data readout: Warning word		No	0	7
541	Data readout: Extended status word		No	0	7
544	Data readout: Pulse count		No	0	7

FCM 300 / FCD 300 / VLT® 2800 / DP V1 PROFIBUS

PNU #	Parameter description	Factory setting	4-setup	Conv. index	Data type
600	Operating hours		No	73	7
601	Hours run		No	73	7
602	kWh counter		No	2	7
603	Number of cut ins		No	0	6
604	Number of overtemperatures		No	0	6
605	Number of overvoltages		No	0	6
615	Fault log: Error code		No	0	5
616	Fault log: Time		No	0	7
617	Fault log: Value		No	0	3
618	Reset of kWh counter	No reset	No	0	7
619	Reset of running hours counter	No reset	No	0	5
620	Operation mode	Normal operation	No	0	5
621	Nameplate: Unit type		No	0	9
624	Nameplate: Software version		No	0	9
625	Nameplate: LCP identification no.		No	0	9
626	Nameplate: Database identification no.		No	-2	9
627	Nameplate: Power parts version		No	0	9
628	Nameplate: Application option type		No	0	9
630	Nameplate: Communication option type		No	0	9
632	Nameplate: BMC software identification		No	0	9
634	Nameplate: Unit identification for communication		No	0	9
635	Nameplate: Software parts no.		No	0	9
640	Software version		No	-2	6
641	BMC software identification		No	-2	6
642	Power card identification		No	-2	6

4-Setup:

'Yes' means that the parameter can be programmed individually in each of the four Setups, i.e. one single parameter can have four different data values. 'No' means that the data value will be the same in all Setups.

Conversion index:

This number refers to a conversion figure to be used when writing or reading via serial communication with a frequency converter.

See **Data character** in **Serial communication** in the **Design Guide**.

Data type:

Data type shows the type and length of the telegram.

Data type	Description
3	Integer 16
4	Integer 32
5	Unsigned 8
6	Unsigned 16
7	Unsigned 32
9	Text string

■ Index
A

Abbreviations	42
About this manual	2
Active spontaneous messages	35
Alarms	39
Assumptions	2

B

Bus termination	12
Bus termination FCD 300	15
Bus termination VLT 2800	18
Bus time out	32
Bus time out function	32
Bus topology	6

C

Cable connection FCM 300	11
Cable lengths	9
Closing the control loop outside the fieldbus	7
Closing the control loop over the bus	7
Communication partners	5
Connected to the bus line	11
Control word	26, 36
Cyclical transmission	6

D

Defined parameters	37
DP communication relations	20

E

Earth connection	11, 17
Earth connection FCD 300	14
Edit set up selection	37
EMC precautions	11, 14, 17
error codes:	36

F

FCD 300 LEDs	16
FCM 300 LEDs	13
Features of a Master type 1 connection	7
Features of a Master type 2 connection:	7
Features of DP	6
FREEZE/UNFREEZE	24
Function of control word bit 10	32

L

LED	16
-----------	----

LEDs	13
------------	----

M

Master-controlled frequency converters	5
Modified parameters	37

N

number of nodes	9
-----------------------	---

O

Object and data types	23
-----------------------------	----

P

Parameter 502	4
Parameter 904	4
Parameter 918	4
Parameter and data type structure description	22
Parameter list with factory settings	43
PCA - Parameters Characteristics	28
PCA handling	21
PCD	28
PCD config. read	34
PCD config. write	34
PCV	28
Physical connection	11
Physical connection FCD 300	14
Physical connection VLT 2800	17
PPO description	20
PPO type select for DP	34
Principle of data exchange by Profibus DP V0/DP V1	7
Profibus DP	4
Profibus DP V1	4, 7
PROFIBUS specific parameters	31
Protocol select	32

Q

Quick start	4
-------------------	---

R

Response time	8
---------------------	---

S

Single master operation with DP V0	6
Size attribute	22
SPM execution	23
Spontaneous messages	23, 39
Station address	35
Status word	27, 37
Store data values	37

Synchronize and freeze 24

U

Update time..... 8

V

VLT 2800 LEDs 19

W

Warning and alarm messages 39

Warning parameter 1 36

Warnings 39

What you should already know 3



www.danfoss.com/drives

Danfoss can accept no responsibility for possible errors in catalogues, brochures and other printed material. Danfoss reserves the right to alter its products without notice. This also applies to products already on order provided that such alterations can be made without subsequential changes being necessary in specifications already agreed. All trademarks in this material are property of the respective companies. Danfoss and the Danfoss logotype are trademarks of Danfoss A/S. All rights reserved.

