



Quick Guide

VLT[®] 2800

1 Quick Guide

1

1.1 Safety

1.1.1 Warnings

**High Voltage Warning:**

The voltage of the frequency converter is dangerous whenever it is connected to mains. Incorrect installation of the motor or frequency converter may cause damage to the equipment, serious injury or death. Consequently, it is essential to comply with the instructions in this manual as well as local and national rules and safety regulations.

**Warning:**

Touching the electrical parts may be fatal - even after the equipment has been disconnected from mains. Also make sure that other voltage inputs have been disconnected (linkage of DC intermediate circuit). Be aware that there may be high voltage on the DC link even when the LEDs are turned off. Before touching any potentially live parts of the frequency converter, wait at least 4 minutes.

**Leakage Current:**

The earth leakage current from the frequency converter exceeds 3.5 mA. According to IEC 61800-5-1 a reinforced Protective Earth connection must be ensured by means of a min. 10mm² Cu or an additional PE wire - with the same cable cross section as the Mains wiring - must be terminated separately.

To increase safety, install an RCD

Residual Current Device:

This product can cause a DC current in the protective conductor. Where a residual current device (RCD) is used for extra protection, only an RCD of Type B (time delayed) shall be used on the supply side of this product. See also Danfoss Application Note on RCD, MN.90.GX.YY.

Protective earthing of the frequency converter and the use of RCDs must always follow national and local regulations.

**Motor Thermal Protection:**

Protection against Motor overload is not included in the factory setting. If this function is required, set par. 128 *Motor Thermal Protection* to data value *ETR trip* or data value *ETR warning*. For the North American market: The ETR functions provide overload protection of the motor, class 20, in accordance with NEC.

**Installation in high altitudes:**

For altitudes above 2 km, please contact Danfoss regarding PELV.

1**1.1.2 Safety Instructions**

- The frequency converter must be disconnected from the mains if repair work is to be carried out. Check that the mains supply has been disconnected and the prescribed time has passed before removing motor and mains plugs.
- Make sure the frequency converter is properly connected to earth.
- Protect users against supply voltage.
- Protect the motor against overloading according to national and local regulations.
- The earth leakage current exceeds 3.5 mA. For ELCB types, please see application note MN.90.GX.YY.
- The [STOP/RESET] key on the control panel of the frequency converter **does not** disconnect the equipment from mains and is thus **not to be used as a safety switch**.
- Note that the frequency converter has more voltage inputs than L1, L2 and L3 when DC bus terminals are used. Check that all voltage inputs are disconnected and that the prescribed time has passed before repair work is commenced.

1.1.3 Warning against unintended start

1. The motor can be brought to a stop by means of digital commands, bus commands, references or a local stop, while the frequency converter is connected to mains. If personal safety considerations make it necessary to ensure that no unintended start occurs, these stop functions are not sufficient.
2. While parameters are being changed, the motor may start. Consequently, the stop key [STOP/RESET] must always be activated, following which data can be modified.
3. A motor that has been stopped may start if faults occur in the electronics of the frequency converter, or if a temporary overload or a fault in the supply mains or the motor connection ceases.

1.1.4 Use on Isolated Mains

See section *RFI Switch* in the operating instructions regarding use on isolated mains.

It is important to follow the recommendations regarding installation on IT-mains, since sufficient protection of the complete installation must be observed. Not taking care using relevant monitoring devices for IT-mains may result in damage.

1.2 Introduction

Use this Quick Guide to carry out quick and EMC-correct installation of the frequency converter in five steps.

! Read the safety section before installing the unit.

👉 NB! The Operating Instructions, MG. 27.AX.YY, give further examples of installation and describe all functions in detail. The Design Guide, MG. 27.EX.YY, contains extensive information.

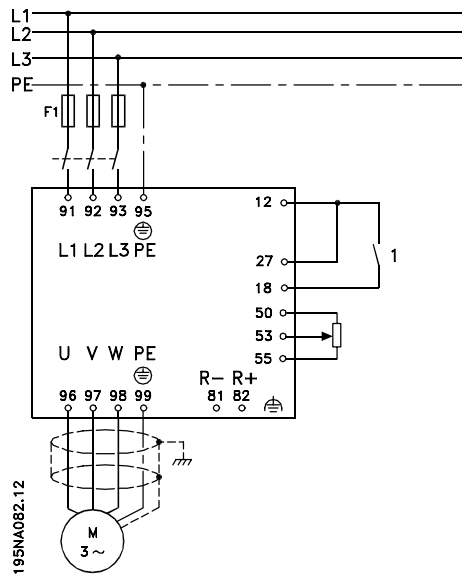

1.2.1 Abbreviations

ELCB	Earth Leakage Circuit Breakers
NO	Normally open
NC	Normally closed
PD2	Dual phase (for 2822, 2840 that only run 3-phase as standard D2), 220 - 240 V
RCD	Residual Current Device

1.2.2 Available Literature

👉 NB! This quick guide contains only the very basic information necessary for installing and running the drive. For more information please consult the VLT 2800 Design Guide, MG.27.EX.YY

1

Title	Literature no.
VLT 2800 Operating Instructions	MG.27.AX.YY
VLT 2800 Design Guide	MG.27.EX.YY
VLT 2800 Data Sheet	MD.27.AX.YY
Mounting Instruction for VLT 2800	MI.28.AX.YY
VLT 2800 Filter Instruction	MI.28.BX.YY
Precise Stop	MI.28.CX.YY
Cold Plate	MI.28.DX.YY
VLT 2800 NEMA 1 Terminal Covering	MI.28.EX.YY
VLT 2800 DeviceNet Cable	MI.28.FX.YY
VLT 2800 Blue Star Condensing Unit	MI.28.GX.YY
VLT 2880 - 2882 Spare Part Instruction	MI.28.HX.YY
Wobble Function	MI.28.JX.YY
VLT 2800 LCP Remote-mounting Kit	MI.56.AX.YY
User Instruction for LOP	MI.90.EX.YY
Brake Resistor	MI.90.FX.YY
Profibus DP Manual	MG.90.AX.YY
VLT 2800 DeviceNet Manual	MG.90.BX.YY
Metasys N2 Manual	MG.90.CX.YY
Profibus Manual	MG.90.EX.YY
Output Filter Manual	MG.90.NX.YY
Brake Resistor Manual	MG.90.OX.YY
MCT-10 Manual	MG.10.RX.YY
Modbus RTU Manual	MG.10.SX.YY
Protection against Electrical Hazards	MN.90.GX.YY

X = Revision Number, Y = Language code

Application notes can be found on <http://www.danfoss.com/BusinessAreas/DrivesSolutions/Documentations/Technical+Documentation.htm>

1.2.3 Approvals



1.2.4 Disposal Instruction

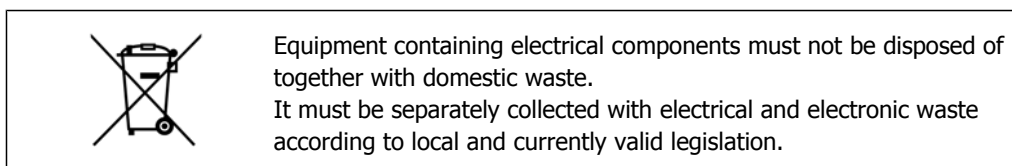

1.3 Mechanical Installation

VLT 2800 frequency converters allow side-by-side installation on a wall in any position as the units do not require ventilation on the side. Because of the need for cooling, there must be 10 cm free air passage above and below the frequency converter.

All units with enclosure IP 20 must be integrated in cabinets and panels. IP 20 is not suitable for remote mounting. In some countries, e.g. in the USA, units with enclosure NEMA 1 are approved for remote mounting.

NB! With the IP 21 solution all units require a minimum of 100 mm air on each side. This means that side-by-side mounting is **NOT** allowed.

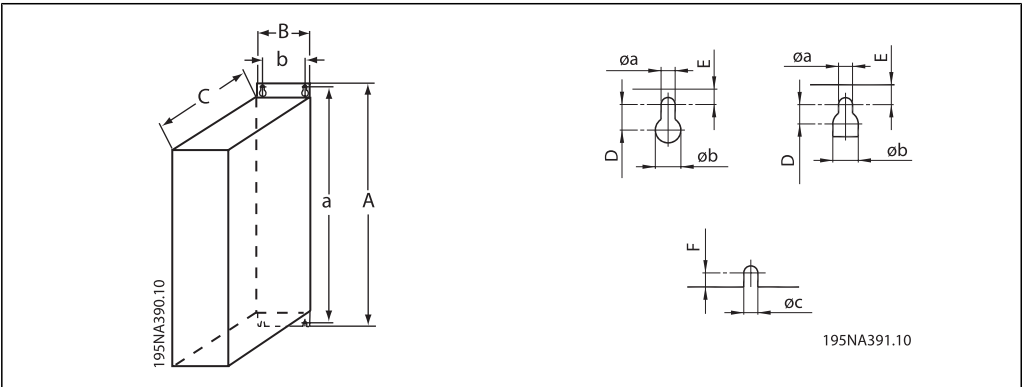

Size mm	A	a	B	b	C	D	E	øa	øb	F	øc
S2											
VLT 2803 - 2815	200	191	75	60	168	7	5	4.5	8	4	4.5
D2											
VLT 2803 - 2815	200	191	75	60	168	7	5	4.5	8	4	4.5
VLT 2822*	267.5	257	90	70	168	8	6	5.5	11	4.5	5.5
VLT 2840*	267.5	257	140	120	168	8	6	5.5	11	4.5	5.5
PD2											
VLT 2822	267.5	257	140	120	168	8	6	5.5	11	4.5	5.5
VLT 2840	505	490	200	120	244	7.75	7.25	6.5	13	8	6.5
T2											
VLT 2822	267.5	257	90	70	168	8	6	5.5	11	4.5	5.5
VLT 2840	267.5	257	140	120	168	8	6	5.5	11	4.5	5.5
T4											
VLT 2805 - 2815	200	191	75	60	168	7	5	4.5	8	4	4.5
VLT 2822 - 2840	267.5	257	90	70	168	8	6	5.5	11	4.5	5.5
VLT 2855 - 2875	267.5	257	140	120	168	8	6	5.5	11	4.5	5.5
VLT 2880 - 2882	505	490	200	120	244	7.75	7.25	6.5	13	8	6.5

Table 1.1: * Only 3-phase

Drill holes in accordance with the measurements given in the above table. Please note the difference in unit voltages.

Retighten all four screws.

Fit the decoupling plate to the power cables and the earth screw (terminal 95).

1.3.1 Motor coils (195N3110) and RFI 1B filter (195N3103)

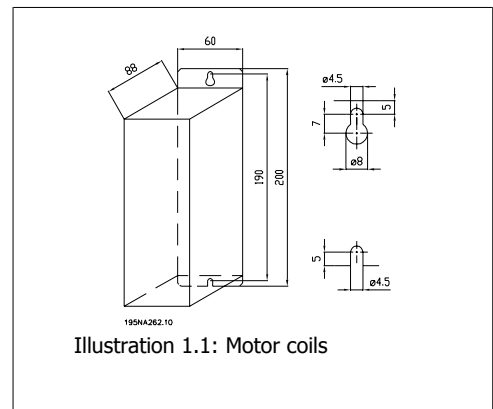
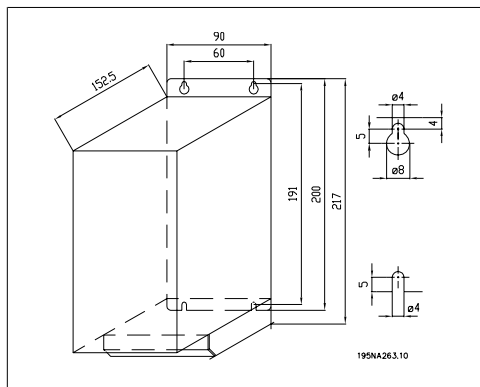
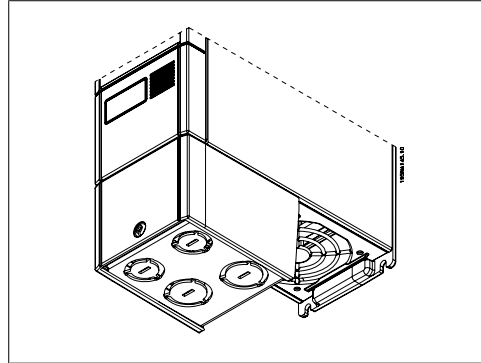
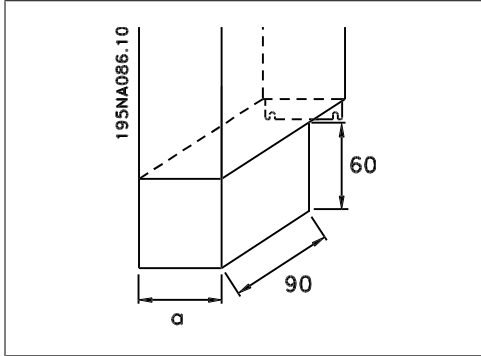

Illustration 1.1: Motor coils

1

1.3.2 Terminal cover

The drawing below gives the dimensions for NEMA 1 terminal covers for VLT 2803-2875. Dimension 'a' depends on the unit type.



1.3.3 IP 21 solution

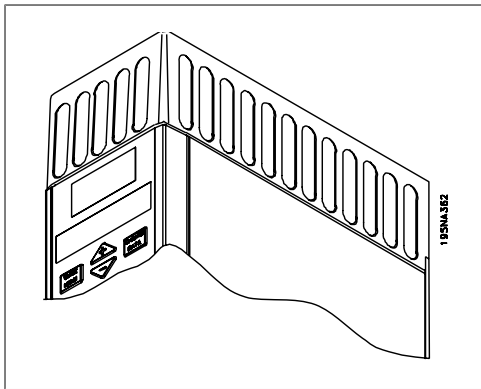

Type	Code number	A	B	C
VLT 2803-2815 200-240 V, VLT 2805-2815 380-480 V	195N2118	47	80	170
VLT 2822 200-240 V, VLT 2822-2840 380-480 V	195N2119	47	95	170
VLT 2840 200-240 V, VLT 2822 PD2, TR1 2855-2875 380-480 V	195N2120	47	145	170
TR1 2880-2882 380-480 V, VLT 2840 PD2	195N2126	47	205	245

Table 1.2: Dimensions

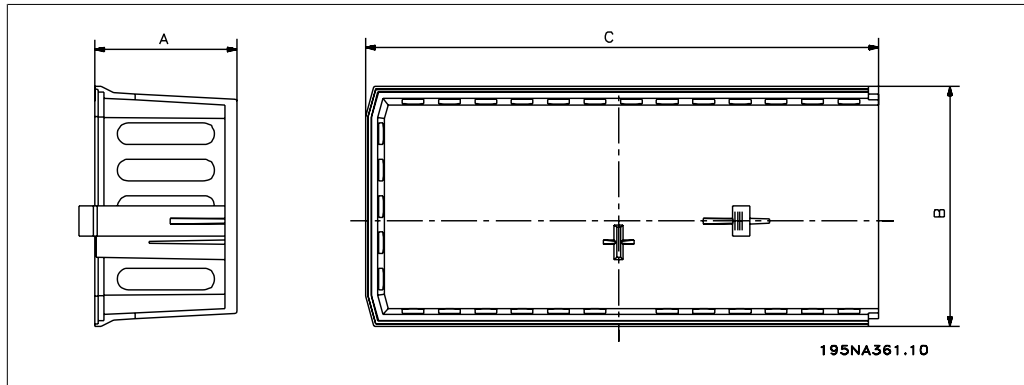

1.3.4 EMC filter for long motor cables

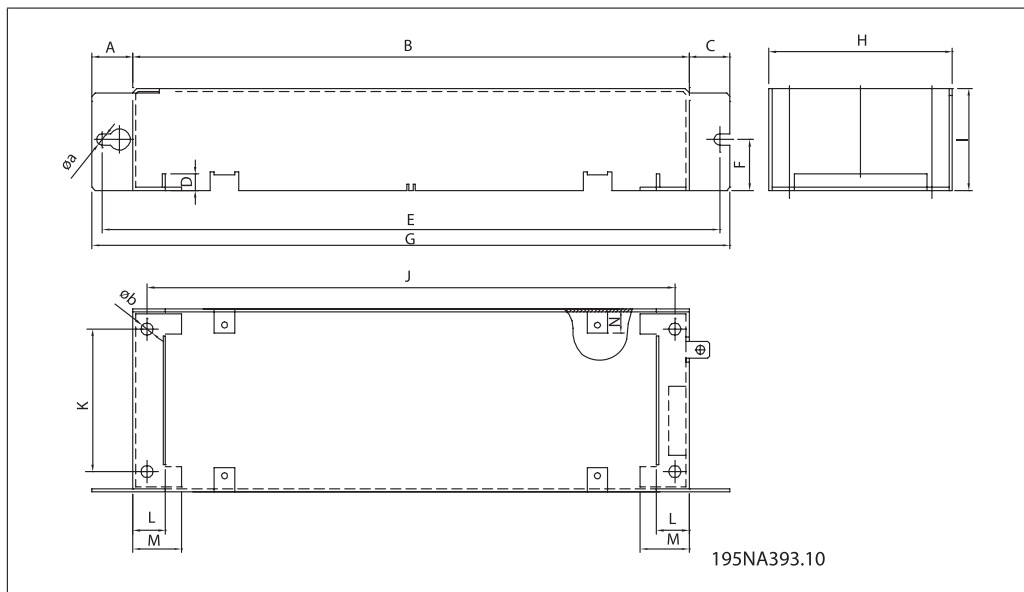

Filter	Dimensions								
	A	B	C	øa	D	E	F	G	
192HA719	20	204	20	5.5	8	234	27.5	244	
	H	I	øb	J	K	L	M	N	
	75	45	6	190	60	16	24	12	
192H4720	A	B	C	øa	D	E	F	G	
	20	273	20	5.5	8	303	25	313	
	H	I	øb	J	K	L	M	N	
	90	50	6	257	70	16	24	12	
192H4893	A	B	C	øa	D	E	F	G	
	20	273	20	5.5	8	303	25	313	
	H	I	øb	J	K	L	M	N	
	140	50	6	257	120	16	24	12	

1

1.4 Electrical Installation

1.4.1 Electrical Installation in General

NB!
All cabling must comply with national and local regulations on cable cross-sections and ambient temperature. Copper conductors required, (60-75° C) recommended.

Details of terminal tightening torques.

VLT	Terminals	Torque (Nm)	Torque, Control Cables (Nm)
2803 - 2875	Power mains brake	0.5 - 0.6	0.22 - 0.25
	Earth	2 - 3	
2880 - 2882, 2840 PD2	Power mains brake	1.2 - 1.5	
	Earth	2 - 3	

Table 1.3: Tightening of terminals.

1.4.2 Power Cables

NB!
Please note that the power terminals can be removed.

Connect mains to the mains terminals of the frequency converter, i.e. L1, L2 and L3 and the earth connection to terminal 95.

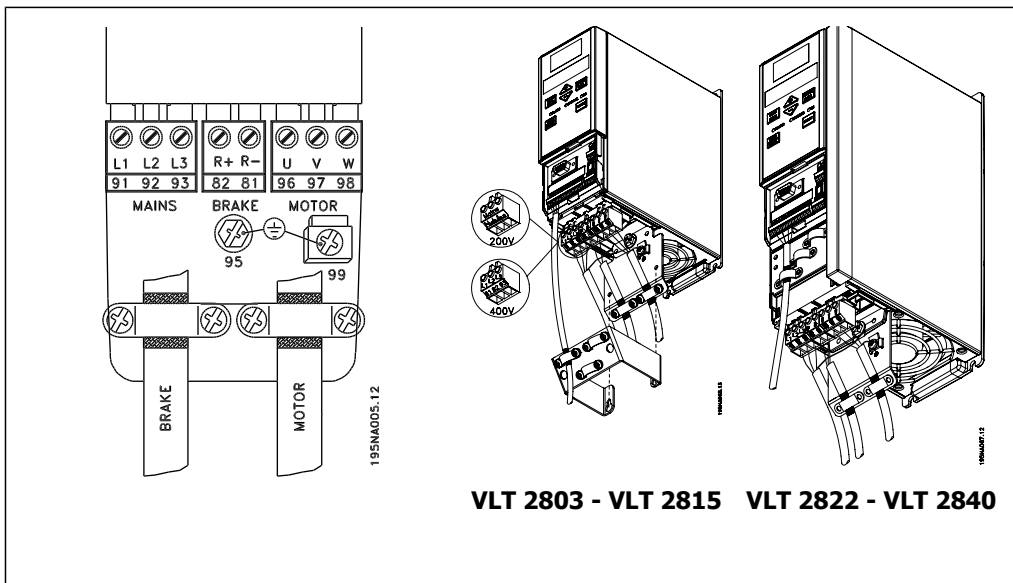

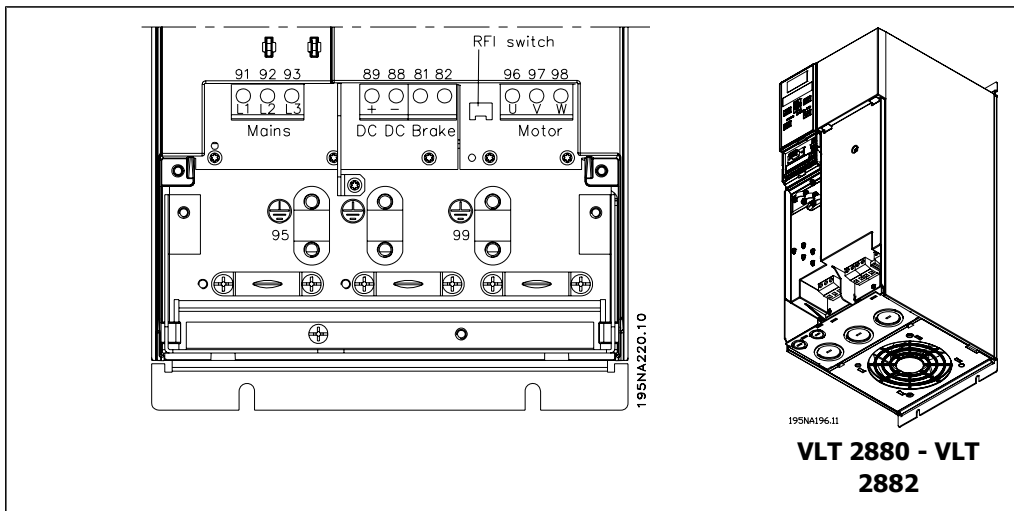

Fit screened/armoured cable from the motor to the motor terminals of the frequency converter, i.e. U, V, W. The screen ends in a screen connector.

1.4.3 Mains connection

 **NB!** Please note that at 1 x 220-240 Volt the neutral wire must be attached to terminal N (L₂) and the phase wire must be connected to terminal L1 (L₁).

No.	N(L ₂)	L1(L ₁)	(L ₃)	Mains voltage 1 x 220-240 V
	N	L1		
No.	95			Earth connection

No.	N(L ₂)	L1(L ₁)	(L ₃)	Mains voltage 3 x 220-240 V
	L2	L1	L3	
No.	95			Earth connection

No.	91	92	93	Mains voltage 3 x 380-480 V
	L1	L2	L3	
No.	95			Earth connection

 **NB!** Please check that the mains voltage fits the mains voltage of the frequency converter, which can be seen from the nameplate.

 400-Volt units with RFI-filters may not be connected to mains supplies in which the voltage between phase and earth is more than 300 Volts. Please note that for the IT mains and the delta earth the mains voltage can exceed 300 Volts between phase and earth. Units with type code R5 (IT mains) can be connected to mains supplies with up to 400 V between phase and earth.

See *Technical data* for correct dimensioning of cable cross-section. See also the section entitled *Galvanic isolation* in the Operating Instructions for further details.

1

1.4.4 Motor connection

Connect the motor to terminals 96, 97, 98. Connect earth to terminal 99.
See *Technical data* for correct dimensioning of cable cross-section.

All types of three-phase asynchronous standard motors can be connected to a frequency converter. Normally, small motors are star-connected ($230/400\text{ V}$, Δ/ Y).

NB!

In motors without phase insulation paper, an LC filter should be fitted on the output of the frequency converter.

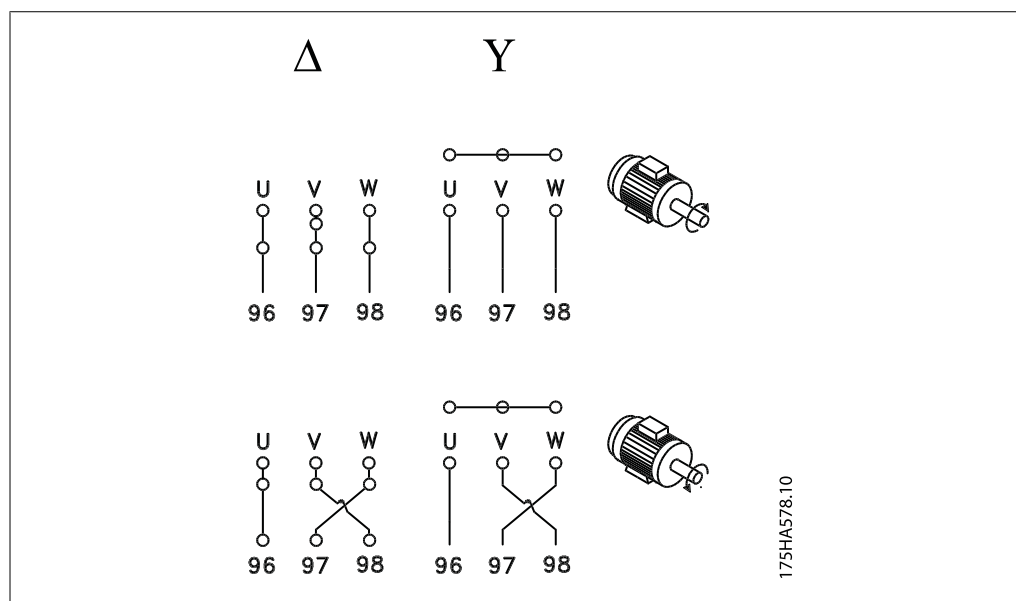

The factory setting is for clockwise rotation.

The direction of rotation can be changed by switching two phases on the motor terminals.

1.4.5 Parallel connection of motors

The frequency converter is able to control several motors connected in parallel.
Please consult the Operating Instructions for further information.

NB!

Be aware that the total cable length, listed in the section *EMC Emission*.

NB!

Parameter 107 *Automatic motor adaption*, *AMT* cannot be used when motors are connected in parallel. Parameter 101 *Torque characteristic* must be set to *Special motor characteristics* [8] when motors are connected in parallel.

1.4.6 Motor Cables

See *General Specifications* for correct dimensioning of motor cable cross-section and length. See *EMC Emissions* for relationship between length and EMC emission.

Always comply with national and local regulations on cable cross-section.

**NB!**

If an unscreened/unarmoured cable is used, some EMC requirements are not complied with, see *EMC test results* in the Design Guide.

If the EMC specifications regarding emission are to be complied with, the motor cable must be screened/armoured, unless otherwise stated for the RFI filter in question. It is important to keep the motor cable as short as possible so as to reduce the noise level and leakage currents to a minimum. The motor cable screen must be connected to the metal cabinet of the frequency converter and to the metal cabinet of the motor. The screen connections are to be made with the biggest possible surface area (cable clamp). This is enabled by different installation devices in different frequency converters. Mounting with twisted screen ends (pigtailed) is to be avoided, since these spoil the screening effect at high frequencies. If it is necessary to break the screen to install a motor isolator or motor relay, the screen must be continued at the lowest possible HF impedance.

1.4.7 Motor Thermal Protection

The electronic thermal relay in UL-approved frequency converters has received the UL-approval for single motor protection, when parameter 128 *Motor thermal protection* has been set for *ETR Trip* and parameter 105 *Motor current, I_{M, N}* has been programmed to the rated motor current (see motor nameplate).

1.4.8 Control Cables

Remove the front cover underneath the control panel. Place a jumper between terminals 12 and 27.

Control cables must be screened/armoured. The screen must be connected to the frequency converter chassis by means of a clamp. Normally, the screen must also be connected to the chassis of the controlling unit (use the instructions for the unit in question). In connection with very long control cables and analogue signals, in rare cases depending on the installation, 50/60 Hz earth loops may occur because of noise transmitted from mains supply cables. In this connection, it may be necessary to break the screen and possibly insert a 100 nF capacitor between the screen and the chassis.

See section entitled *Earthing of screened/armoured control cables* in the VLT 2800 Design Guide for the correct termination of control cables.

1

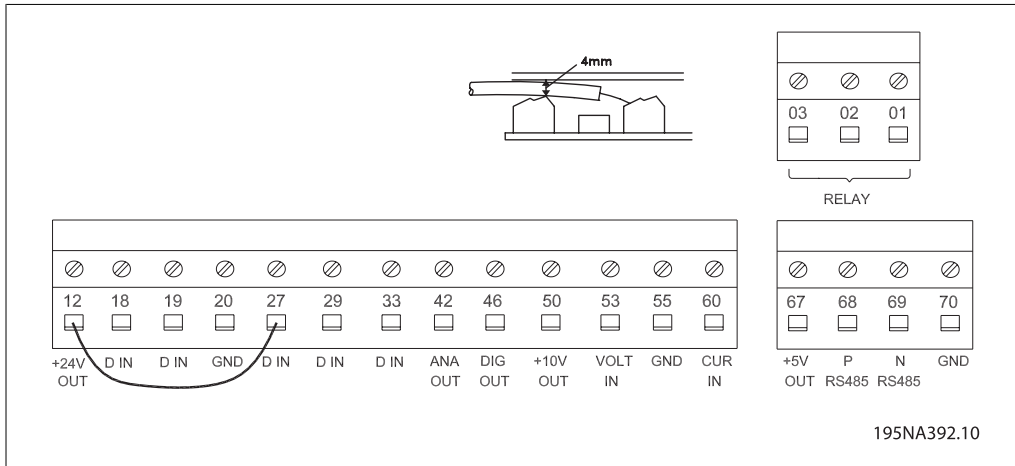

No.	Function
01-03	Relay outputs 01-03 can be used for indicating status and alarms/warnings.
12	24 V DC voltage supply.
18-33	Digital inputs.
20, 55	Common frame for input and output terminals.
42	Analog output for displaying frequency, reference, current or torque.
46 ₁	Digital output for displaying status, warnings or alarms, as well as frequency output.
50	+10 V DC supply voltage for potentiometer or thermistor.
53	Analogue voltage input 0 - 10 V DC.
60	Analogue current input 0/4 - 20 mA.
67 ₁	+ 5 V DC supply voltage to Profibus.
68, 69 ₁	RS 485, Serial communication.
70 ₁	Frame for terminals 67, 68 and 69. Normally this terminal is not to be used.

1. The terminals are not valid for DeviceNet/CANopen. See also the DeviceNet manual, MG. 90.BX.YY for further details.

See parameter 323 *Relay output* for programming of relay output.

Nr.	01 - 02	1 - 2 make (NO)
	01 - 03	1 - 3 break (NC)

 **NB!** Please note that the cable jacket for the relay must cover the first row of control card terminals - otherwise the galvanic isolation (PELV) cannot be maintained. Max. cable diameter: 4 mm.

1.4.9 Earthing

Comply with the following at installation:

- Safety earthing: The drive has a high leakage current and must be earthed properly for safety. Follow all local safety regulations.
- High frequency earthing: Keep earthing connections as short as possible.

Connect all earthing systems to ensure the lowest possible conductor impedance. The lowest possible conductor impedance is achieved by keeping the conductor as short as possible and by grounding with the greatest possible surface area. If multiple drives are installed in a cabinet, the cabinet backplate, which must be made of metal, should be used as a joint earth reference plate. The drives must be fitted to the backplate at the lowest possible impedance.

To achieve low impedance, connect the drive to the backplate with the drive fastening bolts. The backplate must be completely free from paint.

1.4.10 EMC emission

The following system results are achieved on a system consisting of a VLT Series 2800 with screened/armoured control cable, control box with potentiometer, screened/armoured motor cable and screened/armoured brake cable as well as an LCP2 with cable.

VLT 2803-2875	Emission			
	Industrial environment		Residential, commercial and light industry	
	EN 55011 class 1A		EN 55011 class 1B	
Setup	Cable-borne 150 kHz- 30 MHz	Radiated 30 MHz - 1 GHz	Cable-borne 150 kHz - 30 MHz	Radiated 30 MHz - 1 GHz
3 x 480 V version with 1A RFI filter	Yes 25 m screened/ armoured	Yes 25 m screened/ armoured	No	No
3 x 480 V version with 1A RFI filter (R5: For IT mains)	Yes 5 m screened/ armoured	Yes 5 m screened/arm- oured	No	No
1 x 200 V version with 1A RFI filter ¹ .	Yes 40 m screened/ armoured	Yes 40 m screened/ armoured	Yes 15 m screened/ armoured	No
3 x 200 V version with 1A RFI filter (R4: For use with RCD)	Yes 20 m screened/ armoured	Yes 20 m screened/ armoured	Yes 7 m screened/arm- oured	No
3 x 480 V version with 1A+1B RFI filter	Yes 50 m screened/ armoured	Yes 50 m screened/ armoured	Yes 25 m screened/ armoured	No
1 x 200 V version with 1A+1B RFI filter ¹ .	Yes 100 m screened/ armoured	Yes 100 m screened/ armoured	Yes 40 m screened/ armoured	No
VLT 2880-2882	Emission			
	Industrial environment		Residential, commerce and light industry	
	EN 55011 class 1A		EN 55011 class 1B	
Setup	Cable-borne 150 kHz- 30 MHz	Radiated 30 MHz - 1 GHz	Cable-borne 150 kHz - 30 MHz	Radiated 30 MHz - 1 GHz
3 x 480 V version with 1B RFI filter	Yes 50 m	Yes 50 m	Yes 50 m	No

- For VLT 2822-2840 3 x 200-240 V the same values apply as for the 480 V version with 1A RFI filter.

- **EN 55011: Emission**

Limits and methods of measurement of radio disturbance characteristics of industrial, scientific and medical (ISM) high-frequency equipment.

Class 1A:

Equipment used in an industrial environment.

Class 1B:

Equipment used in areas with a public supply network (residential, commerce and light industry).

1**1.4.11 Extra protection**

RCD relays/ELCBs, multiple protective earthing or earthing can be used as extra protection, provided that local safety regulations are complied with.

Three phase VLT frequency converters require an RCD type B. If an RFI filter is mounted in the drive and either the switch of the RCD or a manually operated switch is used to connect the drive to the mains voltage, a time delay of minimum 40 ms is required (RCD type B).

If no RFI filter is mounted or a CI contactor is used for mains connection, no time delay is required.

Single phase VLT frequency converters require an RCD type A. There is no particular need for a time delay whether RFI filters are mounted or not.

See application note MN.90.GX.YY for further information on ELCBs.

1.4.12 EMC-correct electrical installation

General points to be observed to ensure EMC-correct electrical installation.

- Use only screened/armoured motor cables and screened/armoured control cables.
- Connect the screen to earth at both ends.
- Avoid installation with twisted screen ends (pigtailed), since this ruins the screening effect at high frequencies. Use cable clamps instead.
- It is important to ensure good electrical contact from the installation plate through the installation screws to the metal cabinet of the frequency converter.
- Use starwashers and galvanically conductive installation plates.
- Do not use unscreened/unarmoured motor cables in the installation cabinets.

The illustration below shows EMC-correct electrical installation, in which the frequency converter has been fitted in an installation cabinet and connected to a PLC.

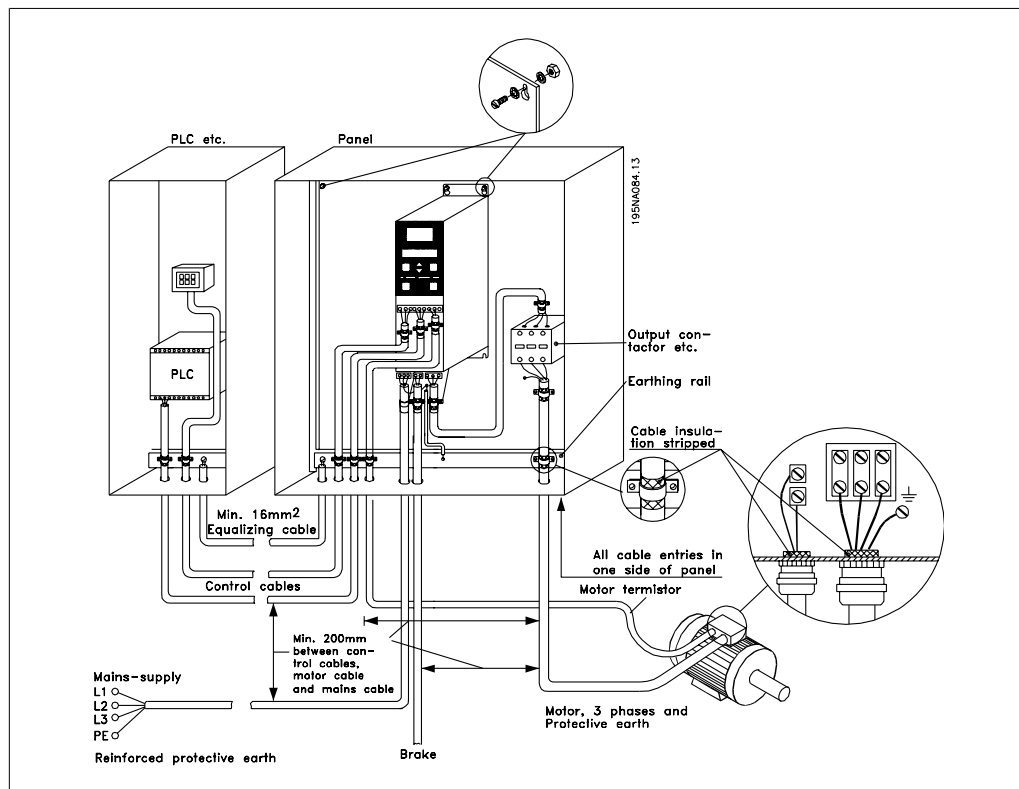

1.4.13 Fuses

Branch circuit protection:

In order to protect the installation against electrical and fire hazard, all branch circuits in an installation, switch gear, machines etc., must be short-circuited and overcurrent protected according to national/international regulations.

Short circuit protection:

Danfoss recommends using the fuses mentioned in the following table to protect service personnel or other equipment in case of an internal failure in the unit or short-circuit on DC-link. The frequency converter provides full short circuit protection in case of a short-circuit on the motor or brake output.

Overcurrent protection:

Provide overload protection to avoid overheating of the cables in the installation. Overcurrent protection must always be carried out according to national regulations. Fuses must be designed for protection in a circuit capable of supplying a maximum of 100,000 A_{rms} (symmetrical), 480 V maximum.

Non UL compliance:

If UL/cUL is not to be complied with, Danfoss recommends using the fuses mentioned in the below table, which will ensure compliance with EN50178/IEC61800-5-1:

In case of malfunction, not following the fuse recommendation may result in damage to the frequency converter.

1

Alternative fuses 380-500 V drives										
VLT 2800	Bussmann E52273	Bussmann E4273	Bussmann E4273	Bussmann E4273	Bussmann E4273	Bussmann E4273	SIBA E18027 6	Little Fuse E81895	Ferraz-Shawmut E16326 7/E2137 7/E2137	Ferraz-Shawmut E16326 7/E2137
	RK1/JDDZ	J/JDDZ	T/JDDZ	CC/JDDZ	CC/JDDZ	CC/JDDZ	RK1/JDDZ	RK1/JDDZ	CC/JDDZ	RK1/JDDZ
2805-2820	KTS-R20	JKS-20	JJS-20	FNQ-R-20	KTK-R-20	LP-CC-20	5017906-020	KLS-R20	ATM-R25	A6K-20R
2855-2875	KTS-R25	JKS-25	JJS-25				5017906-025	KLS-R25	ATM-R20	A6K-25R
2880-2882	KTS-R50	JKS-50	JJS-50				5014006-050	KLS-R50	-	A6K-50R
Alternative Fuses 200-240 V drives										
2803-2822	KTN-R20	JKS-20	JJN-20				5017906-020	KLS-R20	ATM-R25	A6K-20R
2840	KTN-R25	JKS-25	JJN-25				5017906-025	KLS-R25	ATM-R20	A6K-25R

Table 1.4: Prefuses for UL application /cUL

1.4.14 RFI switch

Mains supply isolated from earth:

If the frequency converter is supplied from an isolated mains source (IT mains) or TT/TN-S mains with grounded leg, the RFI switch is recommended to be turned off (OFF). For further reference, see IEC 364-3. In case optimum EMC performance is needed, parallel motors are connected or the motor cable length is above 25 m, it is recommended to set the switch in ON position.

In OFF position, the internal RFI capacities (filter capacitors) between the chassis and the intermediate circuit are cut off to avoid damage to the intermediate circuit and to reduce the earth capacity currents (according to IEC 61800-3).

Please also refer to the application note *VLT on IT mains*, MN.90.CX.02. It is important to use isolation monitors that are capable for use together with power electronics (IEC 61557-8).



NB!

The RFI switch is not to be operated with mains connected to the unit. Check that the mains supply has been disconnected before operating the RFI switch.

The RFI switch disconnects the capacitors galvanically from ground.

The switch Mk9, placed next to terminal 96, should be removed to disconnect the RFI-filter. The RFI switch is only available on VLT 2880-2882.

1.5 Programming

1.5.1 Control Unit

On the front of the frequency converter there is a control panel divided into four sections.

1. Six-digit LED display.
2. Keys for changing parameters and shifting display function.
3. Indicator lamps.
4. Keys for local operation.

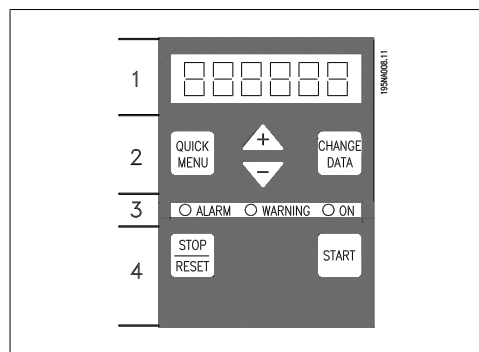

<i>LED indication</i>	
Warning	yellow
Alarm	red
Trip locked	yellow and red

All displays of data are in the form of a six-digit LED display capable of showing one item of operating data continuously during normal operation. As a supplement to the display, there are three indicator lamps for indication of mains connection (ON), warning (WARNING) and alarm (ALARM). Most of the frequency converter's parameter Setups can be changed immediately via the control panel, unless this function has been programmed as *Locked* [1] via parameter 018 *Lock for data changes*.

1.5.2 Control Keys

[QUICK MENU] allows access to the parameters used for the Quick menu.

The [QUICK MENU] key is also used if a change to a parameter value is not to be implemented. See also [QUICK MENU] + [+].

[CHANGE DATA] is used for changing a setting.

If the display shows three dots at the right, the parameter value has more than three digits. In order to see the value, activate [CHANGE DATA]

The [CHANGE DATA] key is also used for confirming a change of parameter settings.

[+] / [-] are used for selecting parameters and for changing parameter values.

These keys are also used in Display mode for selecting the display of an operating value.

The **[QUICK MENU] + [+]** keys must be pressed at the same time to give access to all parameters. See *Menu mode*.

[STOP/RESET] is used for stopping the connected motor or for resetting the frequency converter after a trip.

Can be selected as *Active* [1] or *Not active* [0] via parameter 014 *Local stop/reset*. In Display mode, the display will flash if the stop function is activated.

1

**NB!**

If the [STOP/RESET] key is set at *Not active* [0] in parameter 014 *Local stop/reset*, and there is no stop command via the digital inputs or serial communication, the motor can only be stopped by disconnecting the mains voltage to the frequency converter.

[START] is used for starting the frequency converter. It is always active, but the [START] key cannot override a stop command.

1.5.3 Manual initialisation

Disconnect mains voltage. Hold the [QUICK MENU] + [+] + [CHANGE DATA] keys down while simultaneously reconnecting the mains voltage. Release the keys; the frequency converter has now been programmed for the factory setting.

1.5.4 Display Readout States

In normal operation, one item of operating data can be displayed continuously at the operator's own choice. By means of the [+/-] keys the following options can be selected in Display mode:

- Output frequency [Hz]
- Output current [A]
- Output voltage [V]
- Intermediate circuit voltage [V]
- Output power [kW]
- Scaled output frequency $f_{out} \times p008$

1.5.5 Menu mode

In order to enter the Menu mode [QUICK MENU] + [+] must be activated at the same time. In Menu mode, most of the frequency converter parameters can be changed. Scroll through the parameters using the [+/-] keys. While scrolling in the Menu mode proceeds, the parameter number will flash.

1.5.6 Quick menu

Using the [QUICK MENU] key, it is possible to access the 12 most important parameters of the frequency converter. After programming, the frequency converter is in most cases ready for operation. When the [QUICK MENU] key is activated in Display mode, the Quick menu starts. Scroll through the quick menu using the [+/-] keys and change the data values by first pressing [CHANGE DATA] and then changing the parameter value with the [+/-] keys.

The Quick menu parameters are shown in section *Parameter Lists*.

1.5.7 Hand Auto

During normal operation the frequency converter is in Auto mode, where the reference signal is given externally, analog or digital via the control terminals. However, in Hand mode, it is possible to give the reference signal locally via the control panel.

On the control terminals, the following control signals will remain active when Hand mode is activated:

Hand Start (LCP2)	Quick Stop Inverse	Thermistor
Off Stop (LCP2)	Stop Inverse	Precise Stop Inverse
Auto Start (LCP2)	Reversing	Precise Stop/Start
Reset	DC Braking Inverse	Jog
Coasting Stop Inverse	Setup Select LSB	Stop Comm. Via Serial Comm.
Reset and Coasting Stop Inverse	Setup Select MSB	

Switching between Auto- and Hand mode:

By activating the [Change Data] key in [Display Mode], the display will indicate the mode of the frequency converter.

Scroll up/down in order to switch to Hand mode, the reference can be changed by using [+]/[-].



NB!

Please note, that parameter 020 may block the choice of mode.

A change of parameter values is saved automatically after a mains failure.

If the display shows three dots at the right, the parameter value has more than three digits. In order to see the value, activate [CHANGE DATA].

Press [QUICK MENU]:

Set the motor nameplate parameters

Motor power [kW]	Parameter 102
Motor voltage [V]	Parameter 103
Motor frequency [Hz]	Parameter 104
Motor current [A]	Parameter 105
Rated motor speed	Parameter 106

Activate AMT

Automatic motor tuning Parameter 107

1. In parameter 107 *Automatic motor tuning* select data value [2]. "107" will now flash, and "2" will not flash.
2. AMT is activated by pressing start. "107" will now flash and dashes will move from left to right in the data value field.
3. When "107" appears once more with the data value [0], AMT is complete. Press [STOP/RESET] to save the motor data.
4. "107" will then continue to flash with the data value [0]. You can now proceed.

1

**NB!**

VLT 2880-2882 do not have the AMT function.

Set reference rangeMin. reference, Ref_{MIN} Parameter 204Max. reference, Ref_{MAX} Parameter 205**Set ramp time**

Ramp-up time [s] Parameter 207

Ramp-down time [s] Parameter 208

In parameter 002, *Local/remote control*, the frequency converter mode can be selected as *Remote operation* [0], i.e. via the control terminals, or *Local* [1], i.e. via the control unit.

Set the control location to *Local* [1]Local/remote operation = *Local* [1], Par. 002**Set the motor speed by adjusting the *Local reference***

Local reference, Par. 003

1.6 Motor Start

Press [START] to start the motor. Set the motor speed by adjusting par. 003, *Local reference*.

Check whether the direction of rotation of the motor shaft is clockwise. If not, exchange any two phases on the motor cable.

Press [STOP/RESET] to stop the motor.

Press [QUICK MENU] to return to display mode.

[QUICK MENU] + [+] keys must be pressed simultaneously to give access to all parameters.

1.7 Connection Examples

More examples can be found in the Operating Instructions (MG.27.AX.YY).

1.7.1 Start/Stop

Start/stop using terminal 18 and coasting stop using terminal 27.

Par. 302 *Digital input* = *Start* [7]

Par. 304 *Digital input* = *Coasting stop inverted* [2]

For Precise start/stop the following settings are made:

Par. 302 *Digital input* = *Precise start/stop* [27]

Par. 304 *Digital input* = *Coasting stop inverted* [2]

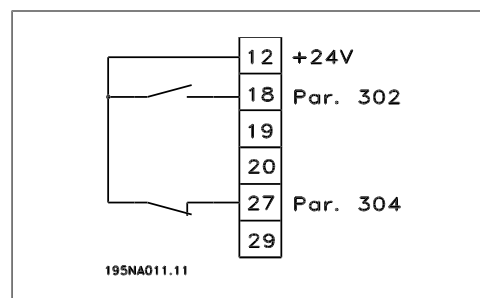

1.8 Parameter List

All parameters are listed in the following. For information on conversion index, data type and further descriptions, please see Operating Instructions (MG.27.AX.YY) or Design Guide (MG.27.EX.YY).

For external communication, please see dedicated literature (see section *Available Literature*).



NB!

Use MCT-10 and USB to RS485 converter to change parameters.

Parameter Overview	
<p>0-XX Operation/Display</p> <p>0-01 Language</p> <ul style="list-style-type: none"> [0] English [1] German [2] French [3] Danish [4] Spanish [5] Italian <p>002 Local/Remote Operation</p> <ul style="list-style-type: none"> [1] Local operation [2] Remote operation <p>003 Local Reference</p> <p>If par. 013 = [1] or [2]: 0 - f_{MAX}, *50 Hz If par. 013 = [3] or [4]: Ref_{MIN} - Ref_{MAX}, *0.0</p> <p>004 Active Set-up</p> <ul style="list-style-type: none"> [0] Factory Set-up [1] Set-up 1 [2] Set-up 2 [3] Set-up 3 [4] Set-up 4 [5] Multi Set-up <p>005 Programming Set-up</p> <ul style="list-style-type: none"> [0] Factory Set-up [1] Set-up 1 [2] Set-up 2 [3] Set-up 3 [4] Set-up 4 [5] Active Set-up <p>0-06 Set-up Copying</p> <ul style="list-style-type: none"> [0] No copying [1] Copy to Set-up 1 from # [2] Copy to Set-up 2 from # [3] Copy to Set-up 3 from # [4] Copy to Set-up 4 from # [5] Copy to all set-ups from # <p>007 LCP Copy</p> <ul style="list-style-type: none"> [0] No copying [1] Upload all parameters [2] Download all parameters [3] Download size-independent parameters 	<p>008 Display Scaling of Output Frequency</p> <p>0.01 - 100.00, *1.00</p> <p>009 Large Display Readout</p> <ul style="list-style-type: none"> [0] No readout [1] Resulting reference [%] [2] Resulting reference [unit] [3] Feedback [unit] [4] Frequency [Hz] [5] Output frequency x scaling [6] Motor current [A] [7] Torque [%] [8] Power [kW] [9] Power [HP] [11] Motor voltage [V] [12] DC link voltage [V] [13] Thermal load motor [%] [14] Thermal load [%] [15] Running hours [Hours] [16] Digital input [Bin] [17] Analog input 53 [V] [19] Analog input 60 [mA] [20] Pulse reference [Hz] [21] External reference [%] [22] Status word [Hex] [25] Heatsink temperature [°C] [26] Alarm word [Hex] [27] Control word [Hex] [28] Warning word [Hex] [29] Extended status word [Hex] [30] Communication option card warning [31] Pulse count <p>010 Small Display Line 1.1</p> <p>See par. 009.</p> <p>[17] Analog input 53</p> <p>011 Small Display Readout 1.2</p> <p>See par. 009.</p> <p>[6] Motor Current [A]</p> <p>012 Small Display Readout 1.3</p> <p>See par. 009.</p> <p>[3] Feedback [unit]</p>
<p>013 Local Control</p> <ul style="list-style-type: none"> [0] Local not active [1] Local control and open loop without slip compensation [2] Remote-operated control and open loop without slip compensation [3] Local control as par. 100 [4] Remote-operated control as par. 100 <p>014 Local Reversing</p> <ul style="list-style-type: none"> [0] Not active [1] Active <p>015 Local Jog</p> <ul style="list-style-type: none"> [0] Not active [1] Active <p>016 Local Lock for Data Changes</p> <ul style="list-style-type: none"> [0] Not locked [1] Locked <p>017 Local reset of Trip</p> <ul style="list-style-type: none"> [0] Not active [1] Active <p>018 Lock for Data Changes</p> <ul style="list-style-type: none"> [0] Not locked [1] Locked <p>019 Operating Mode at Power-up, Local Operation</p> <ul style="list-style-type: none"> [0] Auto re-start, use saved reference [1] Forced stop, use saved reference [2] Forced stop, set ref. to 0 <p>020 Hand Operation</p> <ul style="list-style-type: none"> [0] Not active [1] Active <p>024 Userdefined Quick Menu</p> <ul style="list-style-type: none"> [0] Not active [1] Active <p>025 Quick Menu Set-up</p> <p>Value 0 - 999, *000</p> <p>Load and Motor</p> <p>100 Configuration</p> <ul style="list-style-type: none"> [0] Speed control, open loop 	<p>[2] Speed control, closed loop</p> <p>[3] Process control, closed loop</p> <p>101 Torque Characteristic</p> <ul style="list-style-type: none"> [1] Constant torque [2] Variable torque low [3] Variable torque medium [4] Variable torque high [5] Variable torque low with CT start [6] Variable torque medium with CT start [7] Variable torque high with CT start [8] Special motor mode <p>102 Motor Power P_{M,N}</p> <p>0.25 - 22 kW, *Dep. on unit</p> <p>103 Motor Voltage U_{M,N}</p> <p>For 200 V units: 50 - 999 V, *230 V For 400 V units: 50 - 999 V, *400V</p> <p>104 Motor Frequency f_{M,N}</p> <p>24 - 1000 Hz, *50 Hz</p> <p>105 Motor Current I_{M,N}</p> <p>0.01 - I_{MAX}, Dep. on motor</p> <p>106 Rated Motor Speed</p> <p>100 - f_{M,N} x 60 (max. 60000 rpm), Dep. on par. 104</p> <p>107 Automatic Motor Tuning, AMT</p> <ul style="list-style-type: none"> [0] Optimisation off [1] Optimisation on <p>108 Stator Resistance Rs</p> <p>0.000 - x.xxx Ω, *Dep. on motor</p> <p>109 Stator Resistance Xs</p> <p>0.00 - x.xx Ω, *Dep. on motor</p> <p>117 Resonance Damping</p> <p>OFF - 100% *OFF%</p> <p>119 High Start Torque</p> <p>0.0 - 0.5 s * 0.0 s</p> <p>120 Start Delay</p> <p>0.0 - 10.0 s * 0.0 s</p>

<p>121 Start Function [0] DC hold during start delay time [1] DC brake during start delay time * [2] Coasting during start delay time [3] Start frequency/voltage clockwise [4] Start frequency/voltage in reference direction 122 Function at Stop * [0] Coasting [1] DC hold</p>	<p>136 Slip Compensation 0 - 150 % * 100 % - 500 % +500% of rated slip compensation, *100% 137 DC Hold Voltage 0 - 100% if max. DC hold voltage, *0% 138 Brake Cut Out Value 0.5 - 132.0/1000.0 Hz, *3.0 Hz 139 Brake Cut In Frequency 0.5 - 132.0/1000.0 Hz, *3.0 Hz 140 Current, Minimum Value 0% - 100% of inverter output current 142 Leakage Reactance Xl 0.000 - xxx.xxx Ω, *Dep- on motor 143 Internal Fan Control * [0] Automatic [1] Always switched on [2] Always switched off 144 Gain AC Brake 1.00 - 1.50, *1.30 146 Reset Voltage Vector * [0] Off [1] Reset</p>	<p>204 Minimum Reference, Ref_{MIN} Par. 100 [0]. -100,000.000 - par. 205 Ref_{MAX} *0.000 Hz Par. 100 [1]/[3], -par. 414 Minimum feedback- par. 205 Ref_{MAX}, *0.000 rpm/par. 416 205 maximum Reference, Ref_{MAX} Par. 100 [0]. Par. 204 Ref_{MIN} - 1000.000 Hz, *50.000 Hz Par. 100 [1]/[3]. Par. 204 Ref_{MIN} - Par. 415 Max Feedback, *50.000 rpm/par. 416 206 Ramp Type * [0] Linear [1] Sin shaped [2] Sin²</p>	<p>221 Current Limit, I_{LIM} 0 - xxx.x% of par. 105, * 160% 223 Warning, Low Current, I_{LOW} 0.0 - par. 224 Warning: High Current, I_{HIGH}, * 0.0 A 224 Warning: High Current, I_{HIGH} 0 - I_{MAX}, * I_{MAX} 225 Warning: Low Frequency, f_{LOW} 0.0 - par. 226 Warn.: High frequency, f_{HIGH}, *0.0 Hz 226 Warning: High Frequency f_{HIGH} If par. 200 = [0]/[1]. Par. 225 f_{LOW} - 132 Hz, * 132.0 Hz If par. 200 [2]/[3]. Par. 225 f_{LOW} - 1000 Hz, * 132.0 Hz 227 Warning: Low Feedback, FB_{LOW} 0.0 - 400.0 Hz * 0.0 Hz-100,000.000 - par. 228 Warn.: FB_{HIGH}, * -4000.000 228 Warning: High Feedback, FB_{HIGH} Par. 227 Warn.: FB_{LOW} - 100,000.000, * 4000.000 229 Frequency Bypass, Bandwidth 0 (OFF) - 100 Hz, * 0 Hz 230 - 231 Frequency Bypass 1 - 2 0 - 100 Hz, *0.0 Hz</p>	<p>302 Terminal 18 Digital Input [0] No function [1] Reset [2] Coasting stop inverse [3] Reset and coasting inverse [4] Quick-stop inverse [5] DC braking inverse [6] Stop inverse * [7] Start [8] Pulse start [9] Reversing [10] Reversing [11] Start Clockwise [12] Start counterclockwise [13] Jog [14] Freeze reference [15] Freeze output frequency</p>
<p>207 Ramp-up Time 1 0.02 - 3600.00 s, * 3.00 s (VLT 2803 - 2875), * 10.00 (2880 - 2882) 208 Ramp-down Time 1 0.02 - 3600.00 s, * 3.00 s (VLT 2803 - 2875), * 10.00 (2880 - 2882) 209 Ramp-up Time 2 0.02 - 3600.00 s, * 3.00 s (VLT 2803 - 2875), * 10.00 (2880 - 2882) 210 Ramp-down Time 2 0.02 - 3600.00 s, * 3.00 s (VLT 2803 - 2875), * 10.00 (2880 - 2882) 211 Jog Ramp Time 0.02 - 3600.00 s, * 3.00 s (VLT 2803 - 2875), * 10.00 (2880 - 2882) 212 Quick-stop Ramp-down Time 0.02 - 3600.00 s, * 3.00 s (VLT 2803 - 2875), * 10.00 (2880 - 2882) 213 Jog Frequency 0.0 - Par. 202 Output Frequency High Limit, f_{MAX} 214 Reference Function * [0] Sum [1] Relative [2] External/preset 215-218 Preset reference 1-4 0.0 - 400.0 Hz * 0.0 Hz-100.00% - +100.00%, * 0.00% 219 Catch Up/Slow Down Reference 0.00 - 100% of the given reference, * 0.00%</p>	<p>References and Limits 200 Output Frequency Range * [0] Only clockwise, 0 - 132 Hz [1] Both directions, 0 - 132 Hz [2] Counterclockwise only, 0 - 132 Hz [4] Both directions, 0 - 1000 Hz [5] Counterclockwise only, 0 - 1000 Hz 201 Output Frequency Low Limit, f_{MIN} 0.0 - f_{MAX}, *0.0 Hz 202 Output Frequency High Limit, f_{MAX} f_{MIN} - 132/1000 Hz (par. 200 Output frequency range, 132 Hz 203 Reference Range [0] Min. reference - Max. reference [1] Analog Input 53 - Max. reference - +Max. reference</p>	<p>133 Start Voltage 0.00 - 100.00 V, *Dep. on unit 134 Load Compensation 0.0 - 300.0%, 100,0% 135 U/f Ratio 0.00 - 20.00 at Hz, *Dep. on unit</p>		

[16] Speed up [17] Speed down [19] Catch up [20] Slow down [21] Ramp 2 [22] Preset ref, LSB [23] Preset ref, MSB [24] Preset reference on [25] Thermistor [26] Precise stop [27] Precise Start Stop [31] Selection of Set-up, LSB [32] Selection of Set-up, MSB [33] Reset and start [34] Pulse counter start	[27] Precise Start Stop [31] Selection of Set-up, LSB [32] Selection of Set-up, MSB [33] Reset and start [34] Pulse counter start	305 Terminal 29 Digital Input See par. 305 * [13] Jog	314 Terminal 60 Analog Input Current [0] No function [1] Reference *[2] Feedback [10] Wobble	[14] Output current lower than I_{HIGH} par. 224 [15] Feedback higher than FB_{LOW} [16] Feedback lower than FB_{HIGH} par. 228 [17] Relay 123 [18] Reversing [19] Thermal warning [20] Local operation [22] Out of frequency range par. 225/226 [23] Out of current range [24] Out of feedback range [24] Mechanical brake control [25] Control word bit 11
307 Terminal 33 Digital Input *[0] No function [1] Reset [2] Coasting stop inverse [3] Reset and coasting inverse [4] Quick-stop inverse [5] DC braking inverse [6] Stop inverse [7] Start [8] Pulse start [9] Reversing [10] Reversing [11] Start Clockwise [12] Start counterclockwise [13] Jog [14] Freeze reference [15] Freeze output frequency [16] Speed up [17] Speed down [19] Catch up [20] Slow down [21] Ramp 2 [22] Preset ref, LSB [23] Preset ref, MSB [24] Preset reference on [28] Pulse reference [29] Pulse feedback [30] Pulse input [31] Selection of Set-up, LSB [32] Selection of Set-up, MSB [33] Reset and start	305 Terminal 29 Digital Input See par. 305 * [13] Jog	307 Terminal 33 Digital Input *[0] No function [1] Reset [2] Coasting stop inverse [3] Reset and coasting inverse [4] Quick-stop inverse [5] DC braking inverse [6] Stop inverse [7] Start [8] Pulse start [9] Reversing [10] Reversing [11] Start Clockwise [12] Start counterclockwise [13] Jog [14] Freeze reference [15] Freeze output frequency [16] Speed up [17] Speed down [19] Catch up [20] Slow down [21] Ramp 2 [22] Preset ref, LSB [23] Preset ref, MSB [24] Preset reference on [28] Pulse reference [29] Pulse feedback [30] Pulse input [31] Selection of Set-up, LSB [32] Selection of Set-up, MSB [33] Reset and start	315 Terminal 60 Min. Scaling 0.0 - 20.0 mA, * 4.0 mA 316 Terminal 60 Max. Scaling 0.0 - 20.0 mA, * 20.0 mA 317 Time Out 1 - 99 s * 10 s 318 *[0] No operation [1] Freeze output frequency [2] Stop [3] Jog [4] Max speed [5] Stop and trip	327 Pulse reference/feedback 150 - 67600 Hz, * 5000 Hz 328 Maximum Pulse 29 150 - 67600 Hz, * 5000 Hz 341 Digital/Pulse Output Terminal 46 [0] Unit ready Par. [0] - [20], see par. 323 [21] Pulse reference Par. [22] - [25], see par. 323 [26] Pulse feedback [27] Output frequency [28] Pulse current [29] Pulse power [30] Pulse temperature 342 Terminal 46, max. Pulse Scaling 150 - 10000 Hz, * 5000 Hz 343 Precise Stop Function *[0] Precise ramp stop [1] Counter stop with reset [2] Counter stop without reset [3] Speed-compensated counter stop [4] Speed-compensated stop with reset [5] Speed-compensated stop without reset Counter Value 0 - 999999, * 100000 pulses 349 Speed Comp Delay 0 ms - 100 ms, * 10 ms Special Functions 400 Brake Function [0] OFF [1] Resistor brake [4] AC brake [5] Load sharing
303 Terminal 19 Digital Input See par. 302 * [9] Reversing	303 Terminal 19 Digital Input See par. 302 * [9] Reversing	304 Terminal 27 Digital Input [0] No function [1] Reset [2] Coasting stop inverse *[3] Reset and coasting inverse [4] Quick-stop inverse [5] DC braking inverse [6] Stop inverse [7] Start [8] Pulse start [9] Reversing [10] Reversing [11] Start Clockwise [12] Start counterclockwise [13] Jog [14] Freeze reference [15] Freeze output frequency [16] Speed up [17] Speed down [19] Catch up [20] Slow down [21] Ramp 2 [22] Preset ref, LSB [23] Preset ref, MSB [24] Preset reference on [25] Thermistor [26] Precise stop	319 Analog output terminal 42 [0] No function [1] External reference min. - max. 0 - 20 mA [2] External reference min. - max. 4 - 20 mA [3] Feedback min. - max. 0-20 mA [4] Feedback min. - max. 4- 20 mA [5] Output frequency 0 - max 0-20 mA [6] Output frequency 0 - max 4-20 mA *[7] Output current 0 - I_{INV} 0-20 mA [8] Output current 0 - I_{INV} 4-20 mA [9] Output power 0- $P_{M,N}$ 0-20 mA [10] Output power 0- $P_{M,N}$ 4-20 mA [11] Inverter temperature 20-100 °C 0-20 mA [12] Inverter temperature 20-100 °C 4-20 mA 323 Relay Output 1-3 [0] No function *[1] Unit ready [2] Enable/no warning [3] Running [4] Running in reference, no warning [5] Running, no warning [6] Running in reference range, no warnings [7] Ready - mains voltage within range [8] Alarm or warning [9] Current higher than current limit [10] Alarm [11] Output frequency higher than f_{low} [12] Output frequency lower than f_{high} [13] Output current higher than I_{low}	329 Pulse reference/feedback 150 - 67600 Hz, * 5000 Hz 328 Maximum Pulse 29 150 - 67600 Hz, * 5000 Hz 341 Digital/Pulse Output Terminal 46 [0] Unit ready Par. [0] - [20], see par. 323 [21] Pulse reference Par. [22] - [25], see par. 323 [26] Pulse feedback [27] Output frequency [28] Pulse current [29] Pulse power [30] Pulse temperature 342 Terminal 46, max. Pulse Scaling 150 - 10000 Hz, * 5000 Hz 343 Precise Stop Function *[0] Precise ramp stop [1] Counter stop with reset [2] Counter stop without reset [3] Speed-compensated counter stop [4] Speed-compensated stop with reset [5] Speed-compensated stop without reset Counter Value 0 - 999999, * 100000 pulses 349 Speed Comp Delay 0 ms - 100 ms, * 10 ms Special Functions 400 Brake Function [0] OFF [1] Resistor brake [4] AC brake [5] Load sharing
304 Terminal 27 Digital Input [0] No function [1] Reset [2] Coasting stop inverse *[3] Reset and coasting inverse [4] Quick-stop inverse [5] DC braking inverse [6] Stop inverse [7] Start [8] Pulse start [9] Reversing [10] Reversing [11] Start Clockwise [12] Start counterclockwise [13] Jog [14] Freeze reference [15] Freeze output frequency [16] Speed up [17] Speed down [19] Catch up [20] Slow down [21] Ramp 2 [22] Preset ref, LSB [23] Preset ref, MSB [24] Preset reference on [25] Thermistor [26] Precise stop	304 Terminal 27 Digital Input [0] No function [1] Reset [2] Coasting stop inverse *[3] Reset and coasting inverse [4] Quick-stop inverse [5] DC braking inverse [6] Stop inverse [7] Start [8] Pulse start [9] Reversing [10] Reversing [11] Start Clockwise [12] Start counterclockwise [13] Jog [14] Freeze reference [15] Freeze output frequency [16] Speed up [17] Speed down [19] Catch up [20] Slow down [21] Ramp 2 [22] Preset ref, LSB [23] Preset ref, MSB [24] Preset reference on [25] Thermistor [26] Precise stop	308 Terminal 53, Analog Input Voltage [0] No function *[1] Reference [2] Feedback [3] Wobble 309 Terminal 53 Min. Scaling 0.0 - 10.0 V, * 0.0 V 310 Terminal 53 Max. Scaling 0.0 - 10.0 V, * 10.0 V		

<p>405 Reset Function * [0] Manual reset [1] Automatic reset x 1 [3] Automatic reset x 3 [10] Automatic reset x 10 [11] Reset at power-up 406 Automatic Restart Time 0 - 10 s, * 5 s 409 Trip Delay Overcurrent, I_{LM} 0 - 60 s (61 = OFF), * OFF 411 Switching Frequency 3000 - 14000 Hz (VLT 2803 - 2875), * 4500 Hz 3000 - 10000 Hz (VLT 2880 - 2882), * 4500 Hz 412 Variable Switching Frequency * [2] Without LC-filter [3] LC-filter connected 413 Overmodulation Function [0] OFF * [1] ON 414 Minimum Feedback, FB_{MIN} -100,000.000 - par. 415, FB_{MAX}, * 0.000 415 Maximum Feedback, FB_{MAX} FB_{MIN} - 100,000.000, * 1500.000 416 Process Units * [0] No unit [1] % [2] ppm [3] rpm [4] bar [5] Cycles/min [6] Pulses/s [7] Units/s [8] Units/min [9] Units/h [10] ° C [11] Pa [12] l/s</p>	<p>[13] m³/s [14] l/min [15] m³/min [16] l/h [17] m³/h [18] Kg/s [19] Kg/min [20] Kg/h [21] T/min [22] T/h [23] Metres [24] Nm [25] m/s [26] m/min [27] ° F [28] In wg [29] Gal/s [30] Ft³/s [31] Gal/min [32] Ft³/min [33] Gal/h [34] Ft³/h [35] Lb/s [36] Lb/min [37] Lb/h [38] Lb ft [39] Ft/s [40] Ft/min 417 Speed PID Proportional Gain 0.000 (OFF) - 1.000, * 0.010 418 Speed PID Integral Time 20.00 - 999.99 ms (1000 - OFF), * 100 ms 419 Speed PID Differential Time 0.00 (OFF) - 200.00 ms, * 20.00 ms 420 Speed PID D-Gain Limit 5.0 - 50.0, * 5.0 421 Speed PID Lowpass Filter Time 20 - 500 ms, * 100 ms</p>	<p>423 U1 Voltage 0.0 - 999.0 V, * par. 103 424 F1 Frequency 0.0 - par. 426, F2 frequency, * Par. 104 425 U2 Voltage 0.0 - 999.0 V, * par. 103 426 F2 Frequency Par. 424, F1 frequency - Par. 428, F3 frequency, * par. 104 427 U3 Voltage 0.0 - 999.0 V, * par. 103 428 F3 Frequency Par. 426, F2 frequency - 1000 Hz, * par. 104 437 Process PID Normal/Inverse Control * [0] Normal [1] Inverse 438 Process PID Anti Windup [0] Not active [1] Active Process PID Start Frequency f_{MIN} - f_{MAX} (par. 201 - par. 202), * par. 201 440 Process PID Proportional Gain 0.0 - 10.00, * 0.01 441 Process PID Integration Time 0.00 (OFF) - 10.00 s, * OFF 442 Process PID Differentiation Time 0.00 (OFF) - 10.00 s, * 0.00 s 443 Process PID Diff. Gain Limit 5.0 - 50.0, * 5.0 444 Process PID Lowpass Filter Time 0.02 - 10.00, * 0.02 445 Flying Start * [0] OFF [1] OK - same direction [2] OK - both directions [2] DC brake and start 451 Speed PID Feedforward Factor 0 - 500 %, * 100 % 452 Controller Range 0 - 200 %, * 10 %</p>	<p>456 Brake Voltage Reduce 0 - 25 V if 200 V, * 0 0 - 50 V if 400 V, * 0 461 Feedback Conversion * [0] Linear [1] Square root 462 Enhanced Sleep Mode Timer Value 0 - 9999 s, * 0 = OFF 463 Boost Setpoint 1 - 200%, * 100% of setpoint 464 Wakeup Pressure Par. 204, Ref_{MIN} - par. 215-218 setpoint, * 0 465 Minimum Pump Frequency Value par. 201, f_{MIN} - par. 202 f_{MAX} (Hz), * 20 466 Maximum Pump Frequency Value par. 201, f_{MIN} - par. 202 f_{MAX} (Hz), * 50 467 Minimum Pump Power 0 - 500.000 W, * 0 468 Maximum Pump Power 0 - 500.000 W, * 0 469 No Flow Power Compensation 0.01 - 2, * 1.2 470 Dry Run Time Out 5 - 30 s, * 31 = OFF 471 Dry Run Interlock Timer 0.5 - 60 min., * 30 min. 484 Initial Ramp OFF/000.1 s - 360.0 s, * OFF 485 Fill Rate OFF/000000.001 - 999999.999 (units/s), * OFF 486 Filled Setpoint Par. 414 - par. 205, * par. 414</p>
---	--	---	--

1

1.9.1 Warnings/alarm messages

No.	Description	W	A	T	Cause of Problem
2	Live zero error (LIVE ZERO ERROR)	X	X	X	Voltage or current signal on terminals 53 or 60 is below 50% of preset value.
4	Mains phase loss (MAINS PHASE LOSS)	X	X	X	No phase on mains supply side.
5	Voltage warning high (DC LINK VOLTAGE HIGH)	X			The intermediate circuit voltage exceeds the limit set.
6	Voltage warning low (DC LINK VOLTAGE LOW)	X			The intermediate circuit voltage is lower the limit set.
7	Overvoltage (DC LINK OVERVOLT)	X	X	X	The intermediate voltage exceeds the limit set.
8	Undervoltage (DC LINK UNDERVOLT)	X	X	X	The intermediate voltage is lower than the limit set.
9	Inverter overload (INVERTER TIME)	X	X		The frequency converter is close to tripping due to overload.
10	Motor overloaded (MOTOR, TIME)	X	X		The motor is too hot due to overload.
11	Motor thermistor (MOTOR THERMISTOR)	X	X		Either the motor is too hot or the thermistor has been disconnected.
12	Current limit (CURRENT LIMIT)	X	X		Output current is higher than set in par. 221.
13	Overcurrent (OVERCURRENT)	X	X	X	The peak current limit has been exceeded.
14	Earth fault (EARTH FAULT)		X	X	Discharge from output phases to earth.
15	Switch mode fault (SWITCH MODE FAULT)		X	X	Fault in switch mode power supply.
16	Short-circuit (CURR. SHORT CIRCUIT)		X	X	Short-circuit on the motor terminals or in the motor.
17	Serial communication timeout (STD BUS TIMEOUT)	X	X		No serial communication to the frequency converter.
18	HPFB bus timeout (HPFB TIMEOUT)	X	X		No serial communication to the communication option card.
33	Out of frequency range (OUT FREQ RNG/ROT LIM)	X			Output frequency has reached the limit set in either par. 201 or par. 202.
34	HPFB communication fault (PROFIBUS OPT. FAULT)	X	X		Fault only occurs in fieldbus versions. Please see par. 953 in fieldbus literature.
35	Inrush fault (INRUSH FAULT)		X	X	Connected to mains too many times within 1 minute.
36	Overtemperature (OVERTEMPERATURE)	X	X		The upper temperature limit has been exceeded.
37-45	Internal fault (INTERNAL FAULT)		X	X	Please contact Danfoss.

W: Warning, **A:** Alarm, **T:** Trip locked

No.	Description	W	A	T	Cause of Problem
50	AMT not possible		X		Either Rs value is outside permitted limits, or motor current is too low on at least one phase, or the motor is too small for AMA.
51	AMT fault re. nameplate data (AMT TYPE.DATA FAULT)		X		Inconsistency between registered motor data.
54	AMT wrong motor (AMT WRONG MOTOR)		X		AMA has detected a missing motor phase.
55	AMT timeout (AMT TIME-OUT)		X		Calculations are taking too long, probably caused by noise on motor cables.
56	AMT warning during AMT (AMT WARN. DURING AMT)		X		Warning is given while AMA is performed.
99	Locked (LOCKED)		X		See par. 018.

W: Warning, **A:** Alarm, **T:** Trip locked

A warning or an alarm will appear in the display as a numerical code **Err. xx**. A warning will be shown on the display until the fault has been corrected, while an alarm will continue to flash until the [STOP/RESET] key is activated. The table shows the various warnings and alarms, and whether the fault locks the frequency converter. After a *Trip locked* the mains supply is cut off and the fault is corrected. The mains supply is reconnected and the frequency converter is reset. The frequency converter is now ready. A *Trip* can be reset manually in three ways:

1. Via the operating key [STOP/RESET].
2. Via a digital input.
3. Via serial communication.

It is also possible to choose an automatic reset in parameter 405 *Reset function*. When a cross appears in both warning and alarm, this can mean that a warning comes before an alarm. It can also mean that it is possible for the user to programme whether a warning or an alarm will appear for a given fault. For example, this is possible in parameter 128 *Motor thermal protection*. After a trip the motor will coast, and alarm and warning will blink on the frequency converter, but if the fault disappears only the alarm will blink. After a reset the frequency converter will be ready to start operation again.

1

1.10 Specifications

1.10.1 Mains Supply 200 - 400 V

According to international standards		Type	2803	2805	2807	2811	2815	2822	2822 PD2	2840	2840 PD2
	Output current (3 x 200-240V)	I_{INV} [A]	2.2	3.2	4.2	6.0	6.8	9.6	9.6	16	16
		I_{MAX} (60s) [A]	3.5	5.1	6.7	9.6	10.8	15.3	10.6	25.6	17.6
	Output power (230 V)	S_{INV} [KVA]	0.9	1.3	1.7	2.4	2.7	3.8	3.8	6.4	6.4
	Typical shaft output	$P_{M,N}$ [kW]	0.37	0.55	0.75	1.1	1.5	2.2	2.2	3.7	3.7
	Typical shaft output	$P_{M,N}$ [HP]	0.5	0.75	1.0	1.5	2.0	3.0	3.0	5.0	5.0
	Max. cable cross section, motor	[mm ² /AWG]	4/10	4/10	4/10	4/10	4/10	4/10	4/10	4/10	16/6
	Input current (1 x 220-240 V)	$I_{L,N}$ [A]	5.9	8.3	10.6	14.5	15.2	-	22.0	-	31.0
		$I_{L,MAX}$ (60s) [A]	9.4	13.3	16.7	23.2	24.3	-	24.3	-	34.5
	Input current (3 x 200-240 V)	$I_{L,N}$ [A]	2.9	4.0	5.1	7.0	7.6	8.8	8.8	14.7	14.7
		$I_{L,MAX}$ (60s) [A]	4.6	6.4	8.2	11.2	12.2	14.1	9.7	23.5	16.2
	Max. cable cross section, power	[mm ² /AWG]	4/10	4/10	4/10	4/10	4/10	4/10	4/10	4/10	16/6
	Max. pre-fuses	IEC/UL [A]	20/2 0	20/2 0	20/2 0	20/2 0	20/2 0	20/2 0	35/3 5	25/2 5	50/5 0
	Efficiency	[%]	95	95	95	95	95	95	95	95	95
	Power loss at 100% load	[W]	24	35	48	69	94	125	125	231	231
	Weight	[kg]	2.0	2.0	2.0	2.0	2.0	3,7	6.0	6.0	18.5 0
	Enclosure	type	IP 20	IP 20	IP 20	IP 20	IP 20	IP 20	IP 20	IP 20	IP 20/ NEM A 1

1.10.2 Mains Supply 380 - 480 V

According to international standards		Type	2805	2807	2811	2815	2822	2830
	Output current (3 x 380-480V)	I_{INV} [A]	1.7	2.1	3.0	3.7	5.2	7.0
		I_{MAX} (60s) [A]	2.7	3.3	4.8	5.9	8.3	11.2
	Output power (400 V)	S_{INV} [KVA]	1.1	1.7	2.0	2.6	3.6	4.8
	Typical shaft output	$P_{M,N}$ [kW]	0.55	0.75	1.1	1.5	2.2	3.0
	Typical shaft output	$P_{M,N}$ [HP]	0.75	1.0	1.5	2.0	3.0	4.0
Max. cable cross section, motor	[mm ² /AWG]	4/10	4/10	4/10	4/10	4/10	4/10	
	Input current (3 x 380-480 V)	$I_{L,N}$ [A]	1.6	1.9	2.6	3.2	4.7	6.1
		$I_{L,MAX}$ (60s)[A]	2.6	3.0	4.2	5.1	7.5	9.8
	Max. cable cross section, power	[mm ² /AWG]	4/10	4/10	4/10	4/10	4/10	4/10
	Max. pre-fuses	IEC/UL [A]	20/20	20/20	20/20	20/20	20/20	20/20
	Efficiency	[%]	96	96	96	96	96	96
	Power loss at 100% load	[W]	28	38	55	75	110	150
	Weight	[kg]	2.1	2.1	2.1	2.1	3.7	3.7
Enclosure	type	IP 20	IP 20	IP 20	IP 20	IP 20	IP 20	

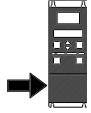
According to international standards		Type	2840	2855	2875	2880	2881	2882
	Output current	I_{INV} [A]	9.1	12	16	24	32.0	37.5
	(3 x 380-480V)	I_{MAX} (60s) [A]	14.5	19.2	25.6	38.4	51.2	60.0
	Output power (400 V)	S_{INV} [KVA]	6.3	8.3	11.1	16.6	22.2	26.0
	Typical shaft output	$P_{M,N}$ [kW]	4.0	5.5	7.5	11.0	15.0	18.5
	Typical shaft output	$P_{M,N}$ [HP]	5.0	7.5	10.0	15.0	20.0	25.0
	Max. cable cross section, motor	[mm ² /AWG]	4/10	4/10	4/10	16/6	16/6	16/6
	Input current	$I_{L,N}$ [A]	8.1	10.6	14.9	24.0	32.0	37.5
	(3 x 380-480 V)	$I_{L,MAX}$ (60s)[A]	13.0	17.0	23.8	38.4	51.2	60
	Max. cable cross section, power	[mm ² /AWG]	4/10	4/10	4/10	16/6	16/6	16/6
	Max. pre-fuses	IEC/UL [A]	20/20	25/25	25/25	50/50	50/50	50/50
	Efficiency	[%]	96	96	96	97	97	97
	Power loss at 100% load	[W]	200	275	372	412	562	693
	Weight	[kg]	3.7	6.0	6.0	18.5	18.5	18.5
	Enclosure type		IP20	IP20	IP20	IP20/ NEMA 1	IP20/ NEMA 1	IP20/ NEMA 1

1.11 General Specifications

Mains supply (L1, L2, L3):

Supply voltage VLT 2803-2840 220-240 V (N, L1)	1 x 220/230/240 V \pm 10%
Supply voltage VLT 2803-2840 200-240 V	3 x 200/208/220/230/240 V \pm 10%
Supply voltage VLT 2805-2882 380-480 V	3 x 380/400/415/440/480 V \pm 10%
Supply voltage VLT 2805-2840 (R5)	380 / 400 V + 10 %
Supply frequency	50/60 Hz \pm 3 Hz
Max. imbalance on supply voltage	\pm 2.0% of rated supply voltage
True Power Factor (λ)	0.90 nominal at rated load
Displacement Power Factor (cos ϕ)	near unity (> 0.98)
Number of connections at supply input L1, L2, L3	2 times/min.
Max. short-circuit value	100,000 A

See *Special Conditions* section in the *Design Guide*

Output data (U, V, W):

Output voltage	0 - 100% of supply voltage
Output frequency	0.2 - 132 Hz, 1 - 1000 Hz
Rated motor voltage, 200-240 V units	200/208/220/230/240 V
Rated motor voltage, 380-480 V units	380/400/415/440/460/480 V
Rated motor frequency	50/60 Hz
Switching on output	Unlimited
Ramp times	0.02 - 3600 sec.

Torque characteristics:

Starting torque (parameter 101 Torque characteristic = Constant torque)	160% in 1 min.*
Starting torque (parameter 101 Torque characteristics = Variable torque)	160% in 1 min.*
Starting torque (parameter 119 <i>High starting torque</i>)	180% for 0.5 sec.
Overload torque (parameter 101 Torque characteristic = Constant torque)	160%*
Overload torque (parameter 101 Torque characteristic = Variable torque)	160%*

Percentage relates to frequency converter's nominal current.

* VLT 2822 PD2 / 2840 PD2 1 x 220 V only 110% in 1 min.

Control card, digital inputs:

Number of programmable digital inputs	5
Terminal number	18, 19, 27, 29, 33
Voltage level	0 - 24 V DC (PNP positive logic)
Voltage level, logic '0'	< 5 V DC
Voltage level, logic '1'	> 10 V DC
Maximum voltage on input	28 V DC
Input resistance, R_i (terminals 18, 19, 27, 29)	approx. 4 k Ω
Input resistance, R_i (terminal 33)	approx. 2 k Ω

All digital inputs are galvanically isolated from the supply voltage (PELV) and other high-voltage terminals. See section entitled Galvanic Isolation in the Operating Instructions.

Control card, analog inputs:

Number of analog voltage inputs	1 pcs.
Terminal number	53
Voltage level	0 - 10 V DC (scaleable)
Input resistance, R_i	approx. 10 k Ω
Max. voltage	20 V
Number of analog current inputs	1 pcs.
Terminal number	60
Current level	0/4 - 20 mA (scaleable)
Input resistance, R_i	approx. 300 Ω
Max. current	30 mA
Resolution for analog inputs	10 bit
Accuracy of analog inputs	Max. error 1% of full scale
Scan interval	13.3 msec

The analog inputs are galvanically isolated from the supply voltage (PELV) and other high-voltage terminals. See section entitled Galvanic Isolation in the Operating Instructions.

Control card, pulse inputs:

Number of programmable pulse inputs	1
Terminal number	33
Max. frequency at terminal 33	67.6 kHz (Push-pull)
Max. frequency at terminal 33	5 kHz (open collector)
Min. frequency at terminal 33	4 Hz
Voltage level	0 - 24 V DC (PNP positive logic)
Voltage level, logic '0'	< 5 V DC
Voltage level, logic '1'	> 10 V DC
Maximum voltage on input	28 V DC
Input resistance, R_i	approx. 2 k Ω
Scan interval	13.3 msec
Resolution	10 bit
Accuracy (100 Hz- 1 kHz) terminal 33	Max. error: 0.5% of full scale
Accuracy (1 kHz - 67.6 kHz) terminal 33	Max. error: 0.1% of full scale

The pulse input (terminal 33) is galvanically isolated from the supply voltage (PELV) and other high-voltage terminals. See section entitled Galvanic Isolation in the Operating Instructions.

Control card, digital/frequency output:

Number of programmable digital/pulse outputs	1 pcs.
Terminal number	46
Voltage level at digital/frequency output	0 - 24 V DC (O.C PNP)
Max. output current at digital/frequency output	25 mA.
Max. load at digital/frequency output	1 k Ω
Max. capacity at frequency output	10 nF
Minimum output frequency at frequency output	16 Hz
Maximum output frequency at frequency output	10 kHz

Accuracy on frequency output	Max. error: 0.2 % of full scale
Resolution on frequency output	10 bit

The digital output is galvanically isolated from the supply voltage (PELV) and other high-voltage terminals. See section entitled Galvanic Isolation in the Operating Instructions.

Control card, analog output:

Number of programmable analog outputs	1
Terminal number	42
Current range at analog output	0/4 - 20 mA
Max. load to common at analog output	500 Ω
Accuracy on analog output	Max. error: 1.5 % of full scale
Resolution on analog output	10 bit

The analog output is galvanically isolated from the supply voltage (PELV) and other high-voltage terminals. See section entitled Galvanic Isolation in the Operating Instructions.

Control card, 24 V DC output:

Terminal number	12
Max. load	130 mA

The 24 V DC supply is galvanically isolated from the supply voltage (PELV), but has the same potential as the analogue and digital inputs and outputs. See section entitled Galvanic Isolation in the Operating Instructions.

Control card, 10 V DC output:

Terminal number	50
Output voltage	10.5 V \pm 0.5 V
Max. load	15 mA

The 10 V DC supply is galvanically isolated from the supply voltage (PELV) and other high-voltage terminals. See section entitled Galvanic Isolation in the Operating Instructions.

Control card, RS 485 serial communication:

Terminal number	68 (TX+, RX+), 69 (TX-, RX-)
Terminal number 67	+ 5 V
Terminal number 70	Common for terminals 67, 68 and 69

Full galvanic isolation. See section entitled Galvanic Isolation in the Operating Instructions. For CANopen/DeviceNet units, see VLT 2800 DeviceNet manual, MG.90.BX.YY.

Relay outputs:¹⁾

Number of programmable relay outputs	1
Terminal number, control card (resistive and inductive load)	1-3 (break), 1-2 (make)
Max. terminal load (AC1) on 1-3, 1-2, control card	250 V AC, 2 A, 500 VA
Max. terminal load (DC1 (IEC 947)) on 1-3, 1-2, control card	25 V DC, 2 A / 50 V DC, 1A, 50W
Min. terminal load (AC/DC) on 1-3, 1-2, control card	24 V DC 10 mA, 24 V AC 100 mA

The relay contact is separated from the rest of the circuit by strengthened isolation.

Note: Rated values resistive load - $\cos\Phi > 0.8$ for up to 300,000 operations.
Inductive loads at $\cos\Phi 0.25$ approximately 50% load or 50% life time.

Cable lengths and cross sections:

Max. motor cable length, screened/armoured cable	40 m
Max. motor cable length, unscreened/unarmoured cable	75 m
Max. motor cable length, screened/armoured cable and motor coil	100 m
Max. motor cable length, unscreened/unarmoured cable and motor coil	200 m
Max. motor cable length, screened/armoured cable and RFI/1B filter	200 V, 100 m
Max. motor cable length, screened/armoured cable and RFI/1B filter	400 V, 25 m
Max. motor cable length, screened/armoured cable and RFI 1B/LC filter	400 V, 25 m

Max. cross section to motor, see next section.

1

Max. cross section to control wires, rigid wire	1.5 mm ² /16 AWG (2 x 0.75 mm ²)
Max. cross section to control cables, flexible cable	1 mm ² /18 AWG
Max. cross section to control cables, cable with enclosed core	0.5 mm ² /20 AWG

When complying with EN 55011 1A and EN 55011 1B the motor cable must in certain instances be reduced. See EMC emission.

Control characteristics:

Frequency range	0.2 - 132 Hz, 1 - 1000 Hz
Resolution of output frequency	0.013 Hz, 0.2 - 1000 Hz
Repeat accuracy of <i>Precise start/stop</i> (terminals 18, 19)	± 0.5 msec
System response time (terminals 18, 19, 27, 29, 33)	26.6 msec
Speed control range (open loop)	1:10 of synchronous speed
Speed control range (closed loop)	1:120 of synchronous speed
Speed accuracy (open loop)	150 - 3600 rpm: Max. error of ±23 rpm
Speed accuracy (closed loop)	30 - 3600 rpm: Max. error of ±7.5 rpm

All control characteristics are based on a 4-pole asynchronous motor

Surroundings:

Enclosure	IP 20
Enclosure with options	NEMA 1
Vibration test	0.7 g
Max. relative humidity	5% - 93% during operation
Ambient temperature	Max. 45 °C (24-hour average max. 40 °C)

Derating for high ambient temperature, see special conditions in the Design Guide

Min. ambient temperature during full-scale operation	0 °C
Min. ambient temperature at reduced performance	- 10 °C
Temperature during storage/transport	-25 - +65/70 °C
Max. altitude above sea level	1000 m

Derating for high air pressure, see special conditions in the Design Guide

EMC standards, Emission	EN 61000-6-4, EN 61800-3, EN 55011 EN 61000-6-1/2, EN 61000-4-2, EN 61000-4-3, EN 61000-4-4, EN 61000-4-5, EN 61000-4-6, EN 61800-3
EMC standards, Immunity	

See section on special conditions in the Design Guide

Safeguards:

- Electronic thermal motor protection against overload.
- Temperature monitoring of the power module ensures that the frequency converter cuts out if the temperature reaches 100 °C. An overload temperature cannot be reset until the temperature of the power module is below 70 °C.

1.12 Special Conditions

1.12.1 Aggressive Environments



The frequency converter is not to be installed in environments, where liquids, particles or gases are in the air that would impact and damage the electronics. Unless the necessary measures are taken to protect the frequency converter, there is a risk of stoppages, which reduce the service life of the frequency converter.

Aggressive gases, such as sulphur, nitrogen and chlorine compounds, together with high humidity and temperature, facilitate possible chemical processes on the components of the frequency converter. These chemical processes quickly impact and damage the electronics. In these areas,

cabinet fitting with fresh-air circulation in the cabinet is recommended, thereby ensuring that aggressive gases are kept away from the frequency converter.

**NB!**

Fitting of frequency converters in aggressive environments increases the risk of stoppages, in addition to considerably reducing the service life of the unit.

Before the frequency converter is installed, it must be checked whether there are liquids, particles or gases in the air. This can be done by looking at existing installations in the same environment. Typical indicators of harmful airborne liquids are water or oil on metal parts or corrosion of metal parts. Too many dust particles are typically observed on top of installation cabinets and on existing electrical installations. Indicators that there are aggressive gases in the air are copper rails and cable ends that are black on existing electrical installations.

1.12.2 Derating for Ambient Temperature

The ambient temperature measured over 24 hours should be at least 5° C lower than the max. ambient temperature.

If the frequency converter is operated above 45° C, the continuous output current should be decreased.

1.12.3 Derating for Low Air Pressure

Above 1000 m the ambient temperature or max. output current must be derated.

For altitudes above 2000 m, please contact Danfoss regarding PELV.

1.12.4 Derating for Running at Low Speeds

When a motor is connected to a frequency converter, it is necessary to check that the cooling of the motor is adequate.

A problem may occur at low speeds in constant torque applications. Running continuously at low speeds – below half the nominal motor speed – may require additional air cooling. Alternatively, choose a larger motor (one size up).

1.12.5 Derating for Long Motor Cables

The frequency converter has been tested using a 75 m unscreened/unarmoured cable and a 25 m screened/armoured cable and has been designed to work using a motor cable with a rated cross-section. If a cable with a larger cross-section is required, it is recommended to reduce the output current by 5% for each step the cable cross-section is increased. (Increased cable cross-section leads to increased capacitance to earth, and thus to an increased earth leakage current).

1.12.6 Derating for High Switch Frequency

The frequency converter will automatically derate the rated output current $I_{VLT,N}$, when the switching frequency exceeds 4.5 kHz.

In both cases, the reduction is carried out linearly, down to 60% of $I_{VLT,N}$.



www.danfoss.com/drives

Danfoss can accept no responsibility for possible errors in catalogues, brochures and other printed material. Danfoss reserves the right to alter its products without notice. This also applies to products already on order provided that such alterations can be made without subsequential changes being necessary in specifications already agreed. All trademarks in this material are property of the respective companies. Danfoss and the Danfoss logotype are trademarks of Danfoss A/S. All rights reserved.

