

IQ 250/260 Transducer Quick Start Guide

Mechanical Installation

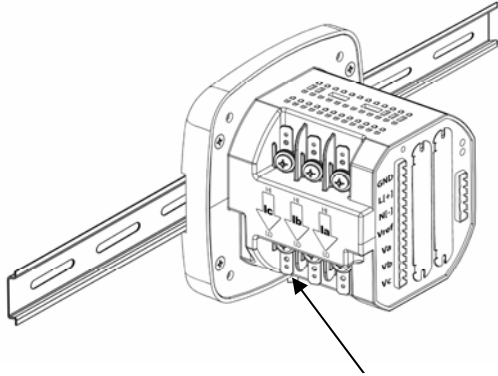

Release Clip

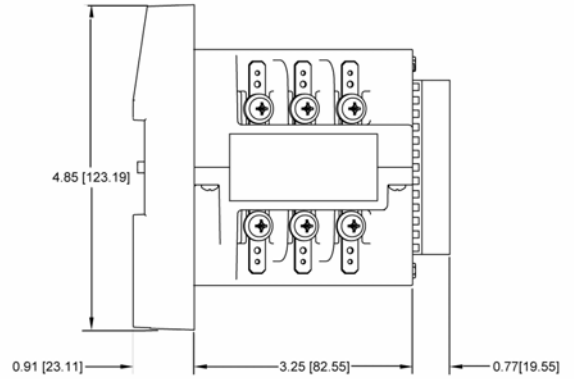

DIN Rail Installation

■ Installation Steps

Slide top of groove of meter onto DIN Rail. Press gently until the meter clicks into place.

If mounting with DIN Rail provided, use Black Rubber Stoppers (also provided) shown below.

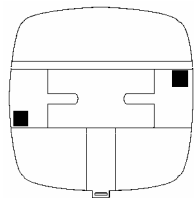

To remove meter, pull down on Release Clip.

Electrical Wiring Diagrams

Select a diagram to meet your application.

NOTE: Other wiring configurations are available. See the IQ 250/260 User and Installation Manual, on the enclosed CD.

IQ 250/260T Dimensions

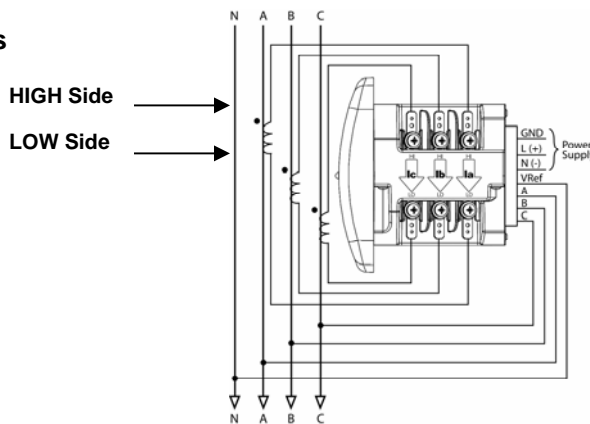

WYE Direct 3 Phase, 4-wire

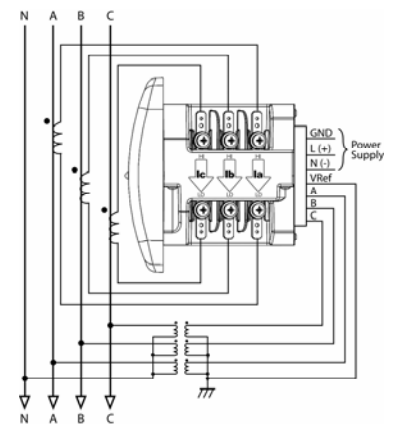

WYE with PTs 3 Phase, 4-wire

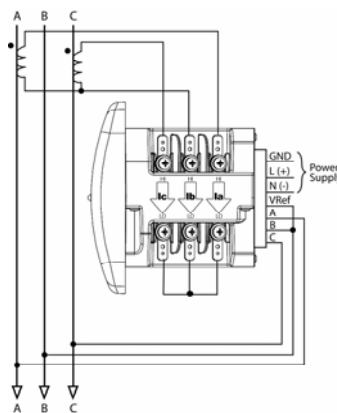

DELTA Direct 3 Phase, 3-wire

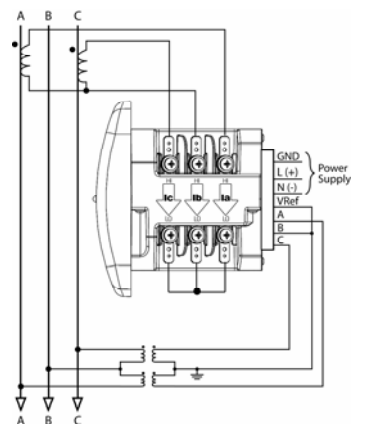

DELTA with PTs 3 Phase, 3-wire

Program the IQ 250/260T Using RS485

Communication Wiring

The IQ 250/260T's RS485 port uses standard 2-wire, Half Duplex Architecture. Connect to Master and Slave devices as shown (+ to +, - to -).

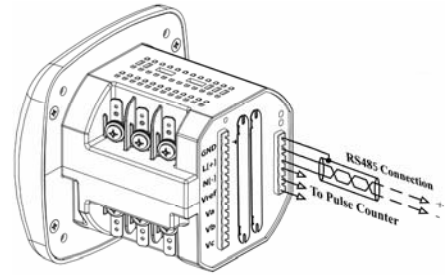

Factory Initial Default Settings

When the IQ 250/260T is powered up, for 10 seconds you can connect to the meter using the Factory Default Settings (even if the Device Profile has been changed). After 10 seconds the Device Profile reverts to the actual Device Profile in use. This is one way you can always connect to the meter. The Factory Initial Default Settings are:

- Device Address:** 1
- Baud Rate:** 9600
- Protocol:** Modbus RTU

Connection Steps

1. Open Eaton Meter Configuration Software.
2. Click **Connect** on the Tool Bar. The Connect screen opens. Make sure your settings match those shown on the right.
3. Click **Connect**. The Device Status screen confirms the connection.
4. Click **OK**. The main screen opens.

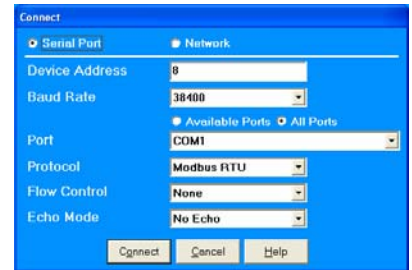

Configuration Steps

5. Click the **Profile** button on the Tool Bar. The Device Profile screen opens, showing the CT, PT Ratios and System Hookup (**Scaling**) fields.
6. Configure Scaling settings based on your application.
7. Click **Communications** and select settings based on your application.

Scaling (CT, PT Ratios and System Wiring)

CT Numerator, Denominator, Multiplier, CT Fullscale (Calculated automatically)
PT Numerator, Denominator, Multiplier, PT Fullscale (Calculated automatically)
System Wiring: Use pull-down menu to select.

Number of Phases: One, Two or Three

NOTE: Voltage Full Scale = PT Numerator x PT Multiplier
 Current Full Scale = CT Numerator x CT Multiplier

IMPORTANT! Specify Primary and Secondary Voltage in Full Scale (NOT Ratios).

Example CT Settings:

- 200/5 Amps: Set the Ct-n value for 200, Ct-S value for 1.
- 800/5 Amps: Set the Ct-n value for 800, Ct-S value for 1.
- 2,000/5 Amps: Set the Ct-n value for 2000, Ct-S value for 1.
- 10,000/5 Amps: Set the Ct-n value for 1000, Ct-S value for 10.

Example PT Settings:

- 14,400/120 Volts: Pt-n value is 1440, Pt-d value is 120, Pt-S value is 10.
- 138,000/69 Volts: Pt-n value is 1380, Pt-d value is 69, Pt-S value is 100.
- 345,000/115 Volts: Pt-n value is 3450, Pt-d value is 115, Pt-S value is 100.
- 345,000/69 Volts Pt-n value is 345, Pt-d value is 69, Pt-S value is 1000.

Communications Settings

- COM2 (RS485):**
- Address** (1-247)
- Protocol** (Modbus RTU, ASCII or DNP)
- Baud Rate** (9600 to 57600)
- Response Delay** (0-750 msec)

Update Device

8. When settings are complete, click the **Update Device** button to send a new profile to the IQ 250/260T.
9. Click **Exit** or click other tabs to update additional screens.
10. Use Eaton Meter Configuration Software to communicate with the device and perform required tasks.

NOTE: For further details and additional programming screens, see the *IQ 250/260 Manual* on the enclosed CD.

