

 **Warning**

**Driver and maintenance personnel must read and understand this manual before operating and maintaining this machine, otherwise, casualty accident may occur. This manual shall be properly kept for relevant personnel's reference and query.**

**L968F WHEEL LOADER  
Operation & Maintenance Manual**

November 2017, Version 1, Printed for the 4th time

---

**SHANDONG LINGONG CONSTRUCTION  
MACHINERY CO., LTD**

*[Faint, illegible text, possibly bleed-through from the reverse side of the page]*





## Preface

Welcome to use rubber-tyred loader produced by Shandong Lingong.

The manual can instruct you to correctly use and maintain the machine, which will be placed in the file pocket behind the seat back in the cab for reference at any time. If the manual cannot be read due to loss or damage, you will contact our company or distributor for timely supplement or replacement.

If you sell the machine, you will guarantee that the manual will be also transferred to new user.

Parameters, charts and relevant contents involved in the manual are applicable to basic model. As for transformed product, you can consult our company or refer to relevant materials. (Note: as for diagram for figurative description in the manual, product appearance will be subject to actual product).

When selecting working machine and tool, you will dismantle, install, replace and use as per operation manuals of working machine and tool.

In addition, you will carefully read technical documents related to operation, use, repair and maintenance of functional parts such as engine and transmission installed on the machine.

The company has been dedicated to enhancement and improvement of our products so that our products will be more advanced and reliable. We will reserve the right for making these changes, but we don't promise that these changes will also be brought to delivered products. We also reserve the right for changing data and machine and instructions for maintenance and repair. Design change and change about instructions for repair and maintenance will be conducted without notification. As for latest information of machine or questions about the manual, you can consult our company.

If you discover any defect when using our products, please timely feedback information to us so that we can constantly enhance product quality and better comply with your demands.

The copyright of the manual is owned by Shandong Lingong Construction Machinery Co., Ltd.. The manual cannot be copied or reprinted without written consent of Shandong Lingong.



### Warning

Only personnel with corresponding qualification through professional training can operate and maintain the machine.

Operators shall carefully read the manual before operating or maintaining the machine. Don't operate, repair and maintain the machine before reading and understanding the manual.

Operation instructions and prevention specified in the manual are only applicable to usage designated for the machine. If it is used in operations beyond the provision that are not prohibited, you must guarantee that this operation will not cause injury to you or others.

Operation and behavior that have been prohibited in the manual cannot be conducted under any circumstance.



# Contents

Preface .....	I
Contents .....	II
Safety Matters .....	V
Identification Number .....	1
Safety .....	2
Pasting position and content of safety sign .....	2
Safety rules .....	13
Safe operation .....	17
Safe starting .....	24
Safe driving .....	28
Safe operation .....	35
Safe parking .....	42
Safety check and repair .....	43
Safe transportation .....	64
Avoid environmental damage .....	66
Product introduction .....	67
Appearance and name of all parts .....	67
Outline dimensional drawing .....	68
Constituent and meaning of product model .....	72
Scutcheon .....	72
Function .....	74
Requirement for working environment .....	74
Characteristics .....	74
Technical performances and parameters .....	76
Product standard .....	78





Operation and utilization.....	79
Get acquaintance with the machine.....	79
Breaking-in of new vehicle .....	115
Use of the loader.....	116
Accessory device.....	135
Release pressure .....	136
Signal Diagram.....	137
Repair and Maintenance.....	139
Repair position .....	139
Maintenance guide .....	141
Clean machine.....	141
Maintenance of painting surface .....	142
Engine.....	142
Fuel system.....	145
Air filter of engine.....	148
Cooling system.....	150
Electrical system.....	153
Transmission box .....	156
Drive axle .....	162
Braking system.....	165
Wheel.....	166
Front window wiper system .....	168
Air conditioning (option) .....	169
Hydraulic system.....	171



Lubricating ..... 174

Detailed utilization rules for oil and coolant..... 174

Selection of oil..... 178

Diagram of lubricating part of loader..... 179

Detailed rules for maintenance of electrical system..... 180

Maintenance tools..... 180

Maintenance table..... 180

System principle diagram..... 184

Transmission system ..... 184

Hydraulic system ..... 185

Braking system ..... 190

Electrical system..... 193



## Safety Matters

Operators shall understand and abide by existing national and local safety provisions. If there are not national or local provisions, operators shall abide by safety instructions in the manual.

Most of accidents are caused as failing to abide by provisions on operation and maintenance of the machine. To avoid occurrence of accident, operators will read, understand and abide by all warning requirements and instructions in the manual and on the machine before operating and maintaining the machine.

Safety measures are specified in the chapter I "safety".

As it is impossible to foresee all possible dangers, safety instructions in the manual and on the machine don't include all safety preventive measures. If steps and operations that are not recommended in the manual have been used, you must guarantee safety of you and others and will not damage the machine. If you cannot confirm safety of some operations, you can consult our company or distributor.

Preventive measures about operation and maintenance specified in the manual are just applicable to usage as per provision. If the machine is used in the scope that has not been listed in the manual, our company will not undertake any safety liability, safety liability in these operations will be undertaken by the user and operators.

Operations prohibited in the manual cannot be conducted under any circumstance.

The following markers are used to identify safety information in the manual:

**⚠** Danger—if it is not avoided, the consequence will cause serious injury or death. This word is also applicable that serious damage will be caused to the machine if the danger is not avoided.

**⚠** Warning—if it is not avoided, consequence of potential danger may cause serious injury or death. This word is also applicable that serious damage will be caused to the machine if the danger is not avoided.

**⚠** Attention—if it is not avoided, it may cause slight or intermediate injury. This word is also applicable that machine damage may be caused or lifetime of the machine may be shortened if the danger is not avoided.





## Identification Number

Identification numbers of the machine and the following parts will be input. Identification number shall be specified when communicating with the manufacturer or purchasing spare parts. Position of scutcheon is shown in the P82.

Manufacturer	Shandong Lingong Construction Machinery Co., Ltd.
Product identification number (PIN)	
Engine	
Transmission	
Front axle	
Rear axle	
Bucket	
Cab	

# Safety

**⚠ Warning**

You must read and execute all safety instructions, otherwise, it may cause serious casualty.

## Pasting position and content of safety sign

Pasting position of safety sign of the machine is shown in the below figure. You will carefully read and abide by all descriptions about safety sign on the machine. You will properly keep safety signs. If safety signs are lost, damaged or unclear, they must be immediately replaced. If component that is equipped with safety sign need be replaced, you shall guarantee new component has corresponding safety sign.

When scrubbing safety signs, cloth and soapy water will be used. Cleaning agent and gasoline cannot be used for scrubbing.

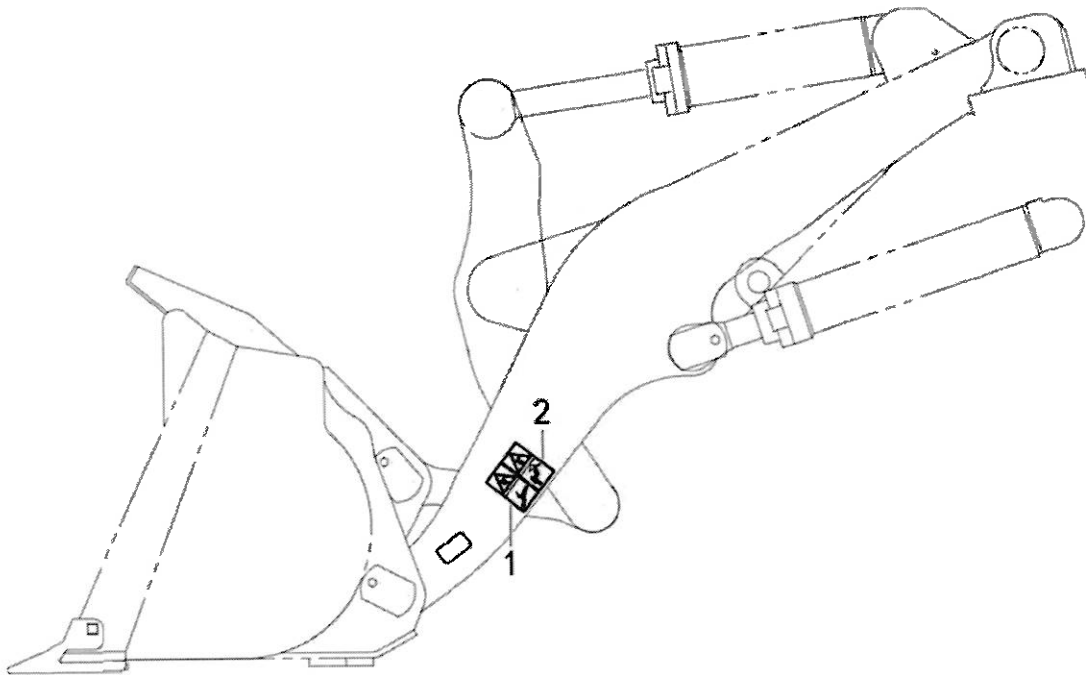

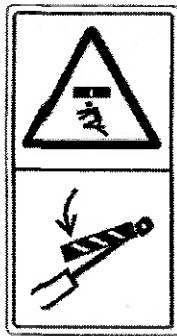

- 1 Safety sign at the position of lifting arm is on two sides of boom.

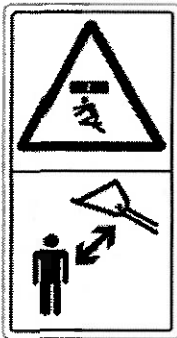

- 2 Danger sign of boom is on two sides of boom.

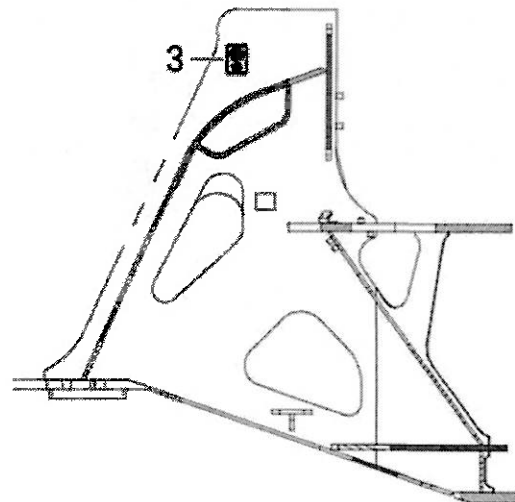
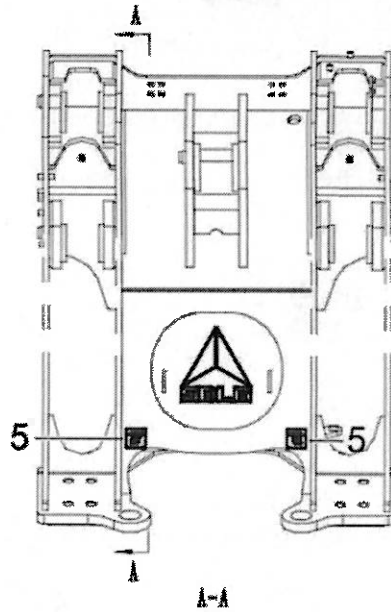
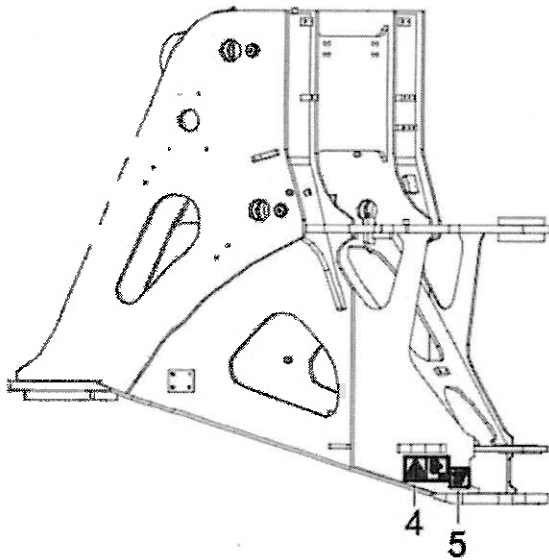

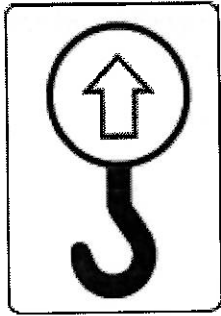

3 Lifting sign is at the lifting place of front and rear frames.

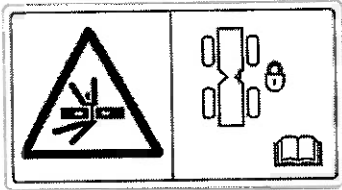

4 Identification of lock-up is near the frame locking rod.

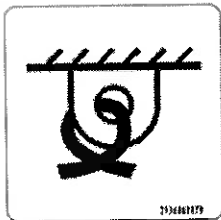

5 Lifting eye sign is at the lifting place of front and rear frames, which is used to fix vehicle and prohibit traction when transporting.

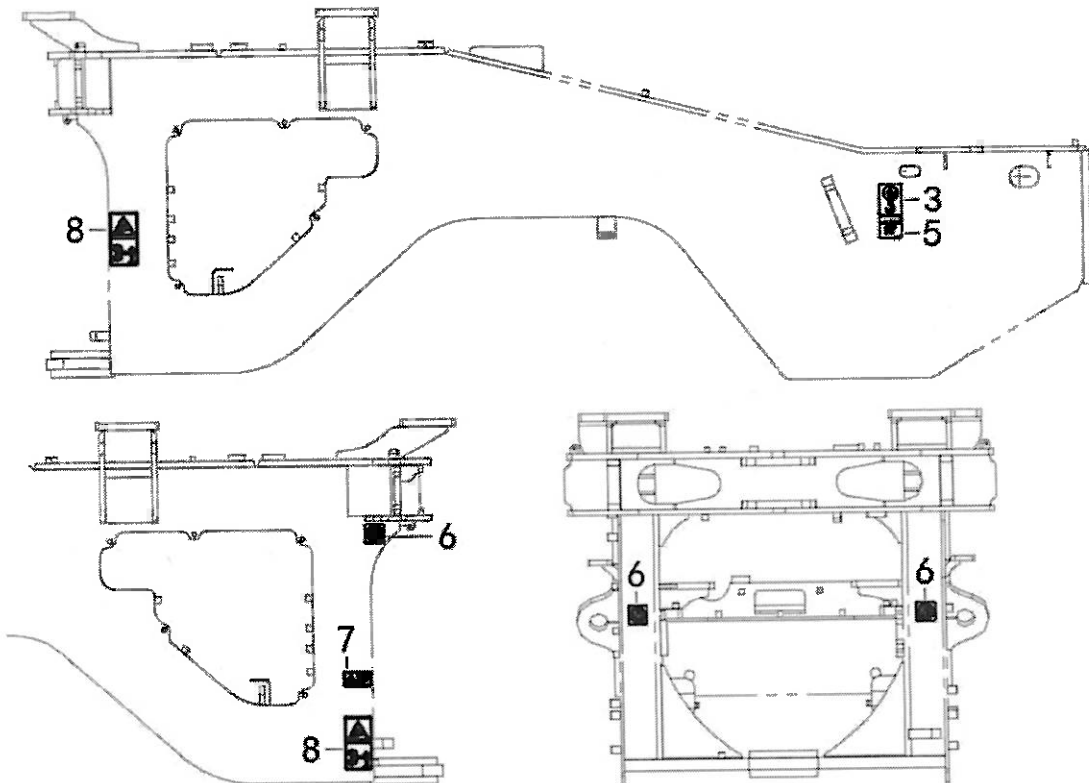



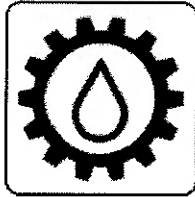

6 Identification of transmission oil is near the filler of transfer box and gearbox.

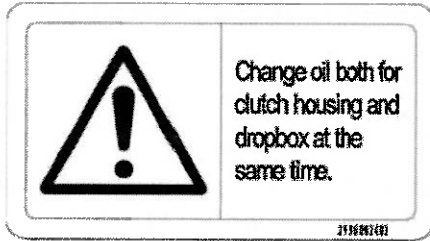

7 Identification of filling transmission oil is near the filler of gearbox and transfer box.



8 Identification of hinge joint steering graph is at hinge joint place of front and rear frames.

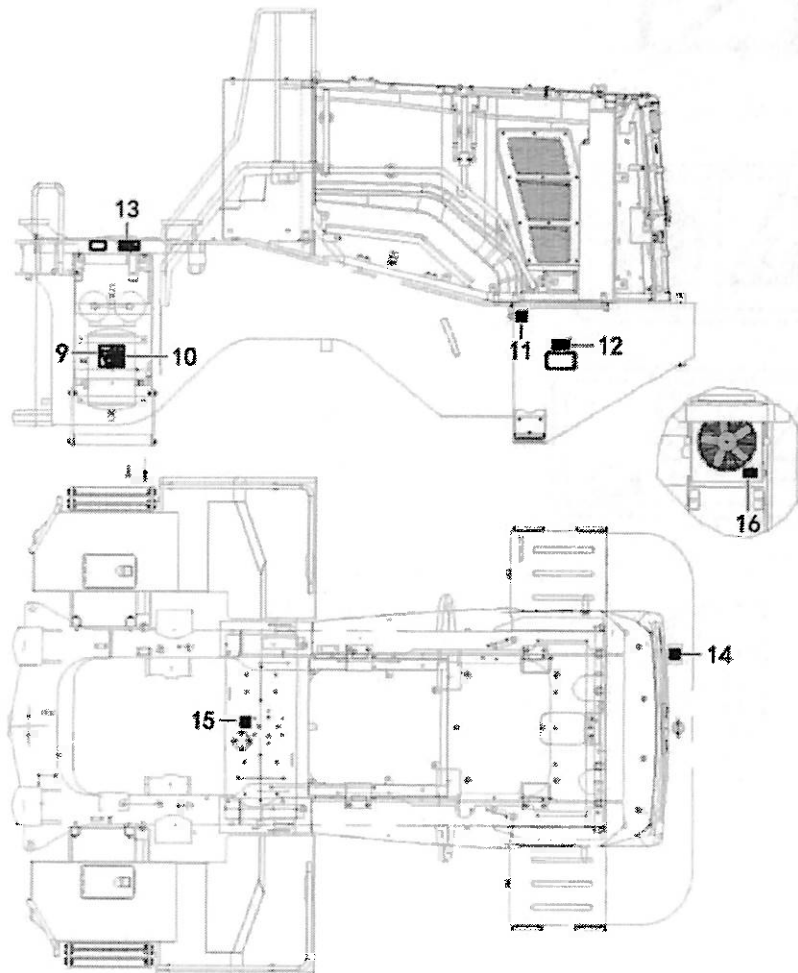

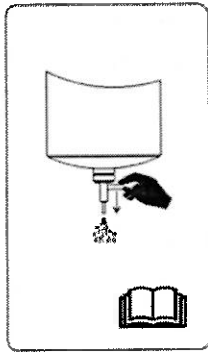

9 Identification of water drainage indication of gas storage tank is near the gas storage tank on the right side of rear frame.



10 Identification for water drainage attention of gas storage tank is near the gas storage tank on the right side of rear frame.

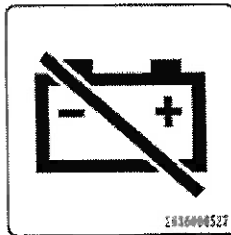

11 Storage battery disconnection identification is on the storage battery box.



12 Sign of smoke prohibition due to explosion of storage battery is on the storage battery box.

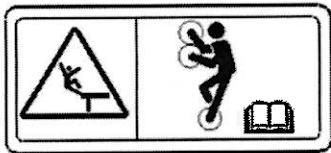

13 Sign for keeping three-point contact is on the left and right racks.

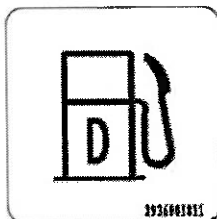

14 Sign of fuel tank is on the fuel tank.

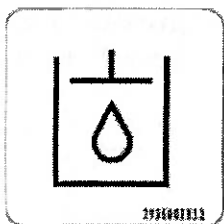

- 15 Sign of hydraulic oil tank is on the hydraulic oil tank.

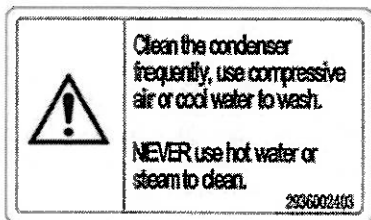

- 16 Sign of periodic cleaning of condenser is on the condenser cover on the right side of the cab

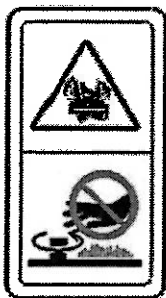
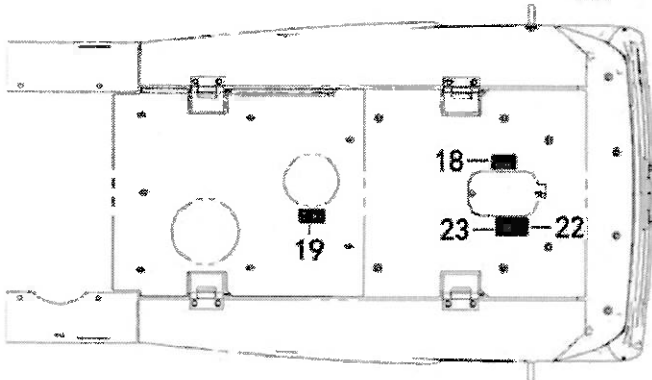
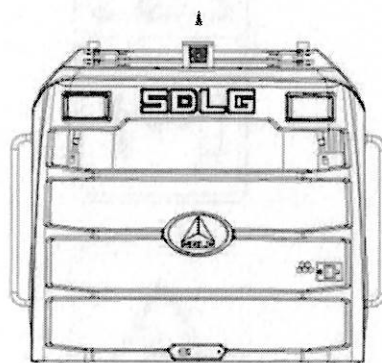
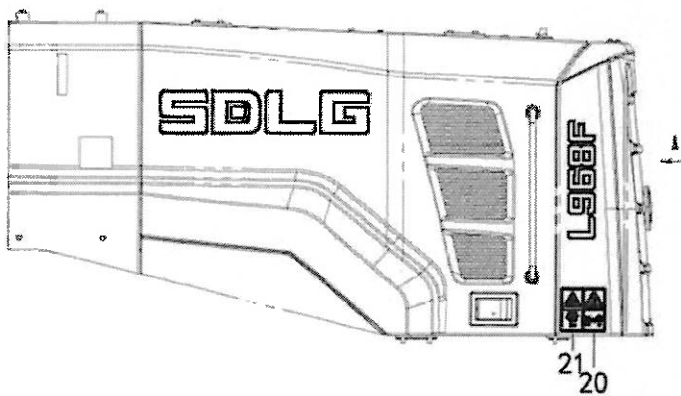

- 18 High temperature fluid attention identification is at water tank of engine hood.

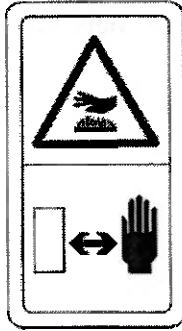

19 Identification for avoiding high temperature burning is on the engine of the engine hood.



20 Safety distance danger sign is on two sides of the engine hood.

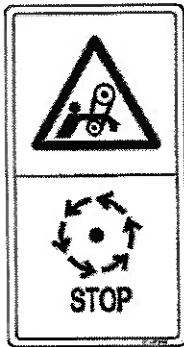

21 Warning sign for contacting machine is on two sides of the engine hood.

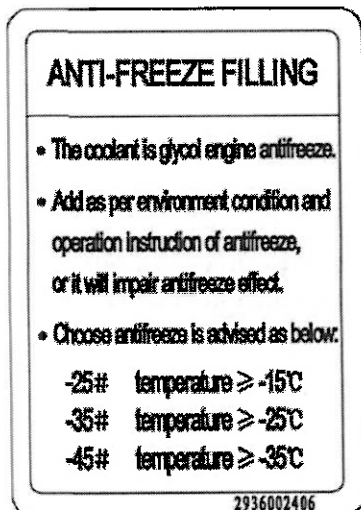

22 Sign of antifreeze is at left door of cab and at filler of water tank of engine hood.

	<p>When replacing antifreeze, the same model must be used. It's forbidden to fill water instead of antifreeze!</p>
--	--

23 Attention identification for filling antifreeze is at the water tank cover of the engine hood.

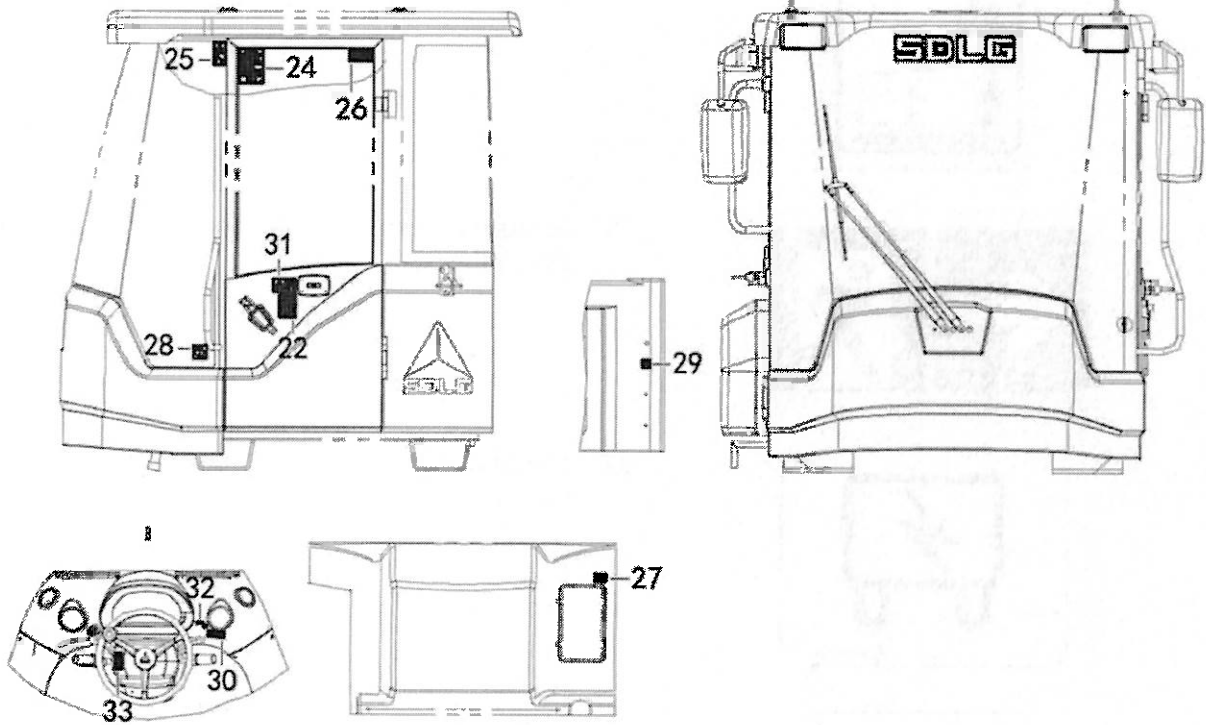

<p><b>CAUTION</b></p>
<p><b>IT IS THE RESPONSIBILITY OF THE OPERATOR TO:</b></p> <ul style="list-style-type: none"> <li>- CHECK ALL FLUID LEVELS DAILY</li> <li>- CHECK TIRE PRESSURES WEEKLY</li> <li>- GREASE DAILY</li> <li>- KEEP MACHINE CLEAN</li> <li>- REPORT ANY MACHINE PROBLEMS</li> <li>- READ MANUAL BEFORE OPERATING</li> </ul> <p>Do Read Manual Before Operating Machine!</p>

24 Operation instruction sign of loader is on the right glass in the cab.

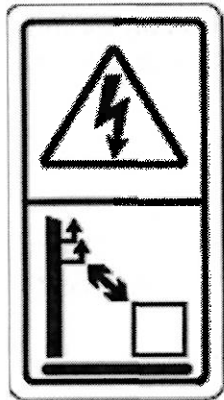

25 Driving attention sign of the loader is on the left glass of the cab.



26 Emergency exit identification is on the right glass of the cab.

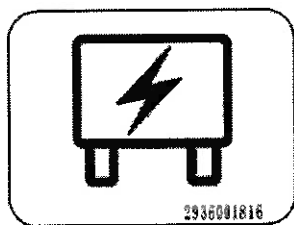

27 Identification of fuse position is near the fuse box cover in the left-rear corner in the cab.

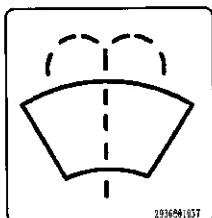

28 Identification of sprinkler of windscreen is at the place of left-front glass in the cab.



29 Identification of installation position of the fire extinguisher is left-rear corner of the cab.

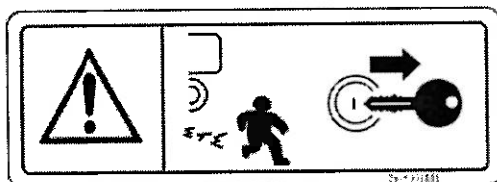

30 Warning sign of starting switch is above the starting switch

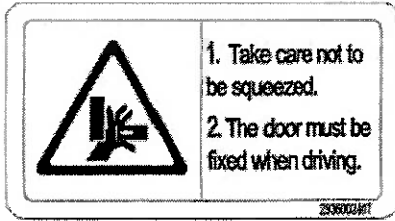

31 Attention sign of cab gate is outside of the cab gate.

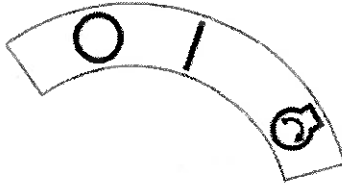

32 Electric lock indication identification is above the starting switch.

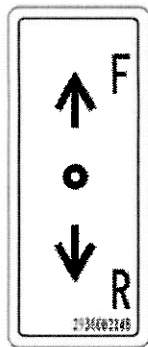

33 Identification of indication of gear control lever is near the gear control lever.

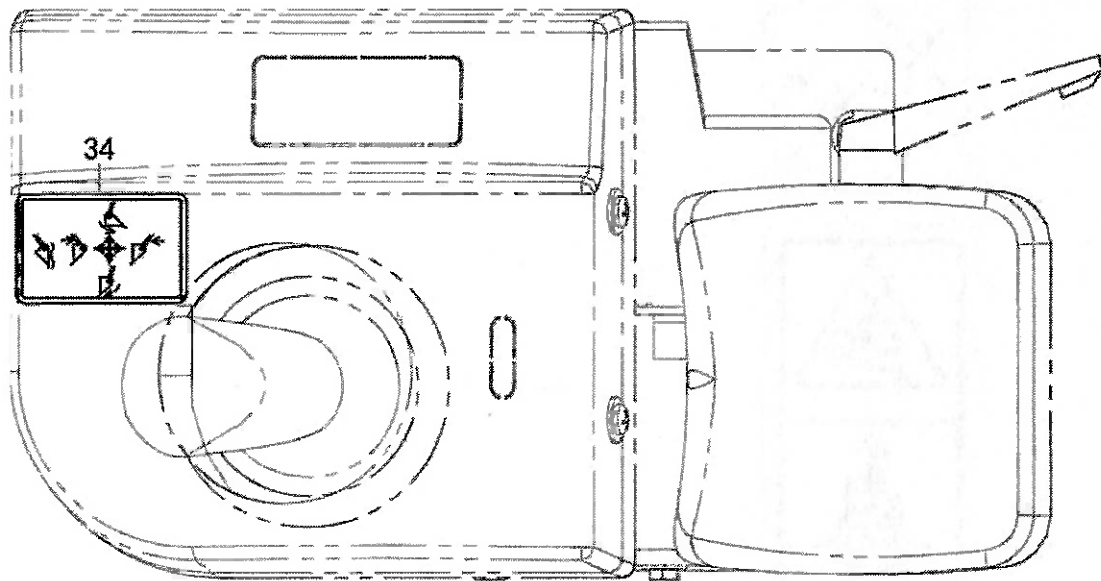

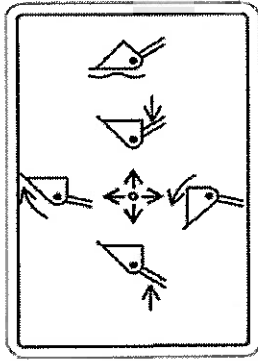

34 Identification of pilot mono-lever control is on the right operation box.

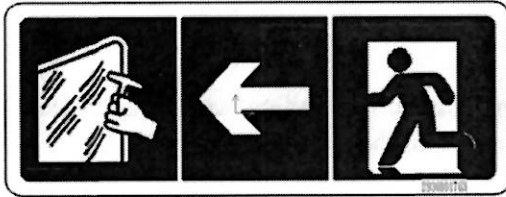

35 Emergency exit identification is on the rear glass of the cab.(with ROPS and FOPS)

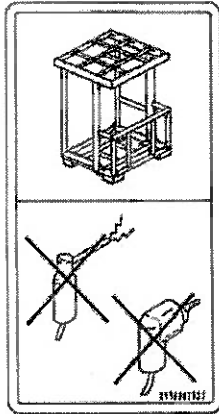

36 Sign for prevent tip-over(if affix) is located on the left glass of the operator cab. (with ROPS and FOPS)

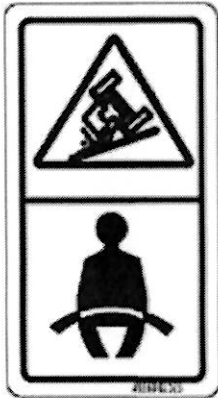

37 Sign for safety belt is located on the left instrument platform in operator cab. (with ROPS and FOPS)

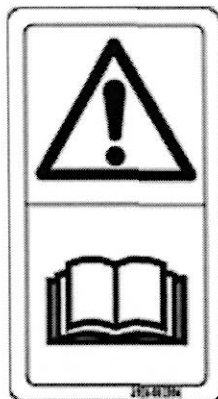

38 Notice of required reading manual is located on the right instrument platform in operator cab. (with ROPS and FOPS)



## Safety rules

The chapter has included provisions that must be abided by to guarantee that the loader can be safely used for work. Of course, these provisions don't conflict with laws and national provisions about traffic safety, industrial safety and labor welfare for operators.

To avoid accident, vigilance, judgment and respect for existing safety provisions are necessary conditions.

## Safety provisions

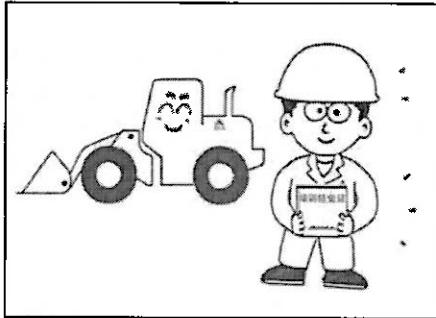

1. Only personnel with corresponding qualification through professional training can operate and maintain the machine.

2. You must be familiar with and abide by all safety provisions, instructions and commands when operating and maintaining the machine. In addition, you must pay attention to statutory and national provisions or special requirements as well as possible danger on the working site.

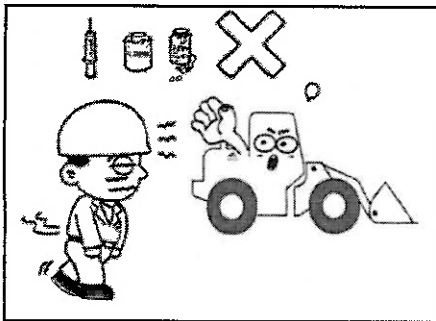

3. You will usually adjust physical condition and don't operate when you are in poor health. If you feel uncomfortable or feel sleepy after eating medicine or drink, you cannot operate the machine. Under this situation, it will cause wrong judgment and accident.

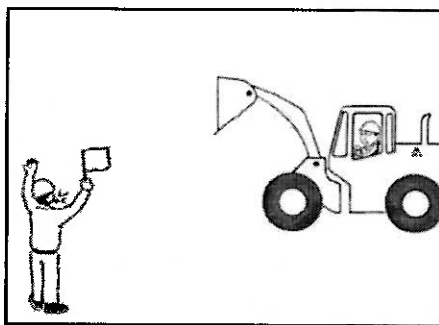

4. When you are working together with other operators or commanders who are responsible for traffic on the construction site, you must guarantee all personnel understand gesture signals.

### Safety device

1. All shields and protective covers are correct positions. Damaged parts are repaired.
2. Safety devices such as joy stick of parking brake and safety belt will be correctly used.
3. Don't dismantle any safety device and guarantee it is under good working state.
4. Incorrect use of safety device may cause serious personal injury or death.
5. If there is danger of fragment splashing as using hydraulic hammer for operation, protective device such as impact-resistant material and mesh protection or protective device with equal protective effect shall be installed.

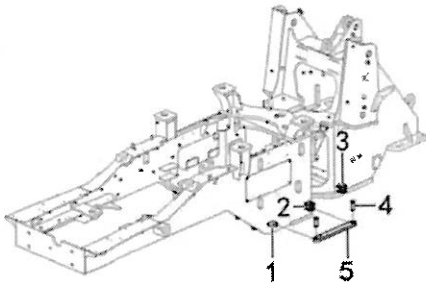

### Locking rod of frame

The locking rod 5 of the frame is used to lock front and rear frames to prevent rotation of front and rear frames when repairing, maintaining or transporting vehicles. When the locking rod of the frame is installed at 1 and 2, it is at the opening position; when it is installed at 2 and 3, it is at the locking position.

After pin roll at 1 or 3 is loosened, locking rod of frame is rotated around 2 and pin roll 4 is fixed at 3 or 1, locking rod of vehicle frame is under locking or opening state.



**Warning: when repairing, maintaining or transporting machine, locking rod of front and rear frames must be used. When normally driving, locking rod of frame must be opened.**

### Fire extinguisher

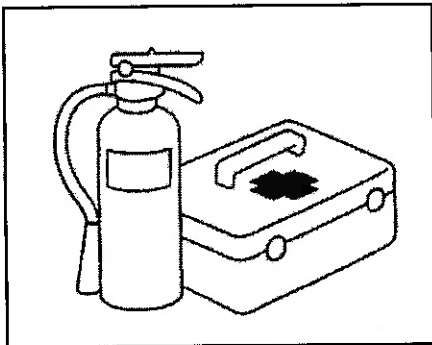

1. The machine has been equipped with installation holder in the lower part of left-rear upright at the driver position of the cab. You must install proper fire extinguisher, carefully instructions for use of the fire extinguisher and must know how to use it.
2. First-aid case must be prepared on the working site, which will be regularly checked. If necessary, some medicines will be prepared. When fire disaster occurs or you are injured, you shall know how to operate.
3. Telephone numbers of some personnel (such as doctor, first-aid center, light of fire station) will be selected for contacting under emergent situation. These telephone numbers will be pasted in stipulated place to guarantee all personnel know these numbers and correct contact methods.

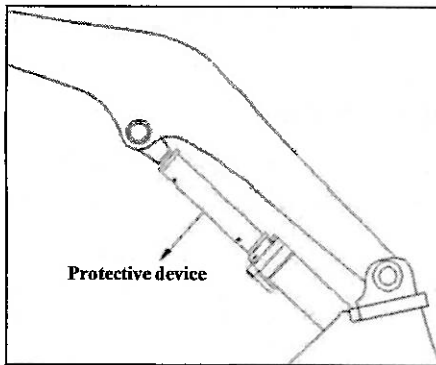

### Protective device (option)

Mounting plate of protective device of the loader will have supporting function when the loader is under no-load situation and boom is lifted to the highest position to prevent boom and bucket from falling for preventing danger.

Installation method: when the loader is under no-load situation, the boom will be lifted to the highest position, mounting plate of boom supporting device is removed from the frame, and bolt is dismantled and placed on the piston rod of the lifting cylinder. In addition, its opening is pointed to downside, and two bolts will be placed in two pairs of long grooves on side of mounting plate. Flat gasket is installed and nut is tightened.

### Bucket

The connection of the bucket will be checked to confirm whether it is reliable or not and confirm whether pin roll has been extended enough or not.

### Other fixation protection device

Relevant tools must be used to dismantle or open fixation protection device such as protecting wire net of fan and engine hood. Unarmed operation is prohibited.

### Safety protection article

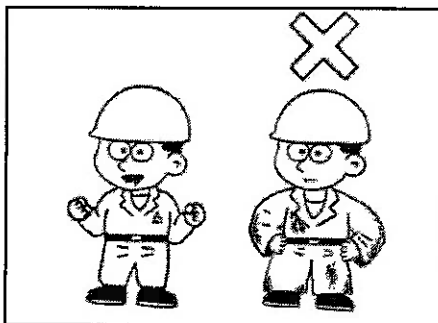
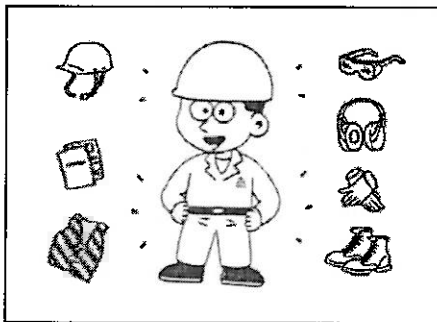

1. When operating or maintaining machine, personal protective articles shall be confirmed in accordance with specific working situations such as safety helmet, safety glasses, safety shoes, reflecting waistcoat or mask, earphone and thick glove that are made of hard materials.
2. When throwing metal chips and tiny sundries, especially when removing sundries in the air filter by using compressed air, you must wear safety glasses and wear safety helmet and thick gloves that are made of hard materials. In addition, check will be conducted to guarantee no person is close to the machine.
3. You cannot wear loose clothes and jewelry and cannot have loose long hair to prevent you from being hooked by control handle or other moving parts to cause casualty.
4. Don't wear clothes with too much oil dirt to prevent burning.
5. Compressed air may cause personal injury. When using compressed air to clean, mask, protective clothes and safety shoes will be worn. The maximum pressure of clean compressed air shall be lower than 0.3MPa.



6. Before using all protective articles, check will be conducted to confirm whether its function is normal or not.

### **Unauthorized transformation**

1. Any transformation without consent of Shandong Lingong Construction Machinery Co., Ltd. may cause danger.
2. Before transforming machine, you can consult Shandong Lingong Construction Machinery Co., Ltd. or its designated distributor.
3. Shandong Lingong Construction Machinery Co., Ltd. will not undertake liability for any damage due to unauthorized transformation.

## Safe operation

### Get acquaintance with the machine

1. *Operation and Maintenance Manual of L968F Rubber-tyred Loader* is on the rear side of the seat in the cab. Before operating and maintaining the machine, you must carefully read the manual to learn machine structure, operation and maintenance and get acquaintance with positions and functions of all buttons, handles, instruments and alarming devices of the machine.
2. You must know various rules and regulations about operation and understand gesture signals of commanders.
3. If oil grease exists in operation position and near the operation position, it must be immediately removed due to risk of slipperiness.
4. Various checks must be accurately conducted before operation. For example: check all safety protective devices to confirm whether they are under safe conditions or not; check tyre to confirm whether it has abrasion or not and whether tyre pressure is normal or not. If ignoring oil leakage, water leakage, air leakage, deformation, looseness and abnormal sound, there will be potential hazards of fault and serious accidents. Therefore, regular check must be conducted.

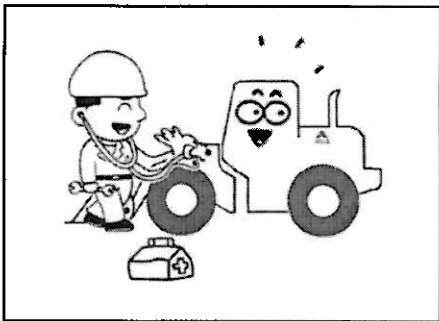
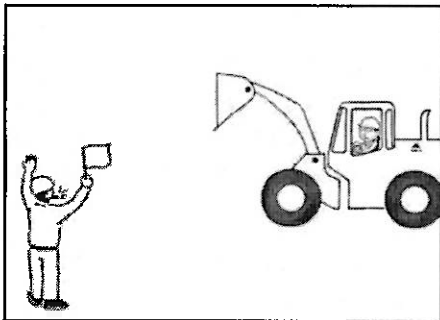

### When driver leaves the seat

1. Parking brake switch is reliably at the brake position.
2. Working device is completely descended to the ground, bucket is placed horizontally, control handle of the transmission and control handle of working device will be placed in the center position, and then the engine will be closed, starting switch is closed and stop dog will be placed on the front and rear tyres if necessary.
3. The vehicle must be locked and key will be kept properly

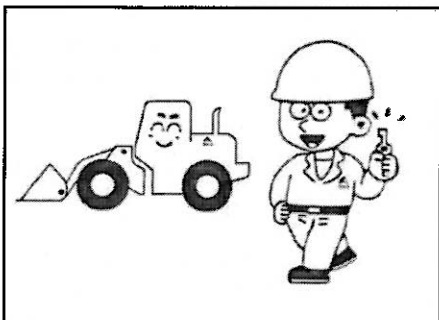

### Boarding machine and leaving the machine

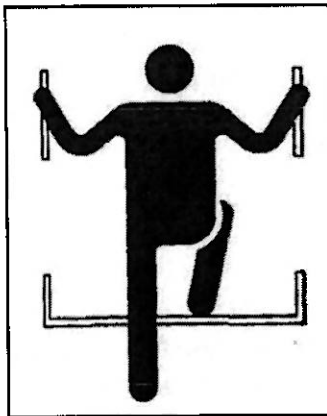
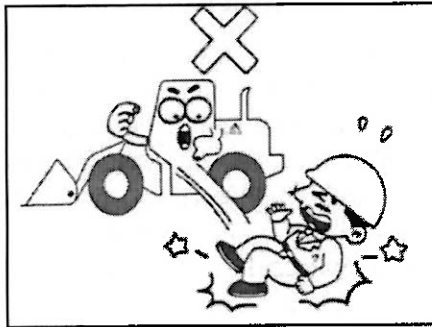

1. Handrail or ladder will be checked before boarding the machine or leaving the machine. If there is oil stains, lubricant or sludge, it shall be immediately cleared to prevent slipping when boarding the machine or leaving the machine. In addition, damaged parts will be repaired and loose bolt will be tightened.
2. Don't jump on or off the machine. When the vehicle is moving, don't get on and off.
3. You must face to the machine, seize the handrail and stamp the ladder to guarantee three-point contact (two feet and one hand or two hands and one foot) and healthy body when boarding the machine or leaving the machine.
4. Don't seize any control handle when boarding the machine or leaving the machine.
5. Don't enter into the cab from the ladder behind the machine or get off the machine from tyre near the cab.
6. Don't climb on or off the machine when carrying tools or other objects on hands, you shall use rope to lift necessary tools to the operation platform.

### Fire protection

Fuel oil and lubricating oil used by the engine of the loader, hydraulic oil used by the hydraulic system, hydraulic transmission oil and gear oil used by the transmission system and antifreeze used by the cooling system are flammable substances, and it is very dangerous if smoke is close to the machine. Attention must be paid to fire protection especially for fuel oil. Therefore, attentions must be paid to the following matters:

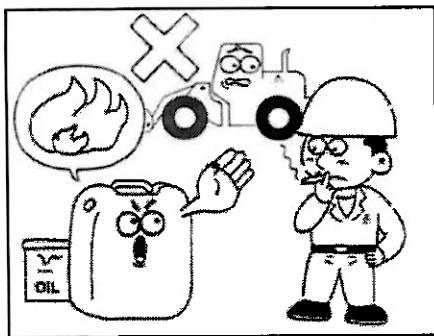

1. Fire source will be kept far away from flammable liquid.
2. The above flammable liquid shall be filled at ventilating place. In addition, the engine shall be closed. It is prohibited to smoke and be close to open fire in the oil filling process.
3. All covers of storage tank of the above flammable liquid will be tightened.
4. The above flammable liquid will be placed in vessel with corresponding marks, placed in fixed place and stored as per category to prevent non-working personnel from use.

5. Electric welding or flame cutting will not be conducted for pipelines containing flammable liquid. Before electric welding or cutting, electric welding or cutting can be conducted after using non-inflammable liquid to clean.
6. Flammable substances such as wood bits, leaves and paper on engine and brake caliper will be completely removed. Fuel oil, lubricating oil or other mince on the machine will be cleared to guarantee there is not oil cloth or other flammable substance.
7. When the machine is working, if the exhaust port of the silencer is close to places where there are flammable substances such as withered grass and paper, special attentions will be paid.
8. When parking vehicles, attention will be paid to surrounding environment of the vehicle. In particular, you shall select the place where there is not flammable substance near high temperature components such as silencer.
9. Check will be conducted to confirm whether fuel oil, lubricating oil and hydraulic oil have leakage or not. If there is leakage, damaged elements shall be immediately repaired or replaced. Operation can be conducted after repairing and cleaning.

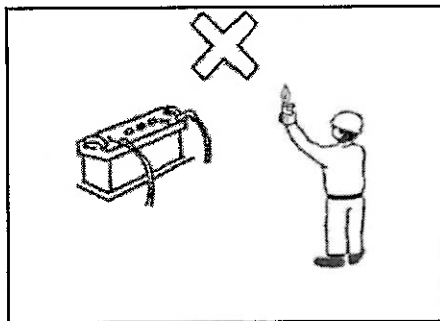

10. Explosive gas will be generated near the storage battery. Smoke is prohibited. The storage battery will be repaired, maintained and used strictly in accordance with product specification.
11. Dark place will be checked. Open fire (matchstick and lighter) cannot be used.
12. Fire extinguisher shall be prepared and you shall know how to use fire extinguisher. The fire extinguisher will be checked and repaired in accordance with operation instruction.
13. The machine cannot be operated near the open fire.
14. Line short circuit is prohibited.

**Safety measures when operating under high temperature**

1. When the work stops, coolant of the engine, engine oil and hydraulic oil are under high temperature and high pressure state. If the cover is removed, oil and water is discharged or filter is replaced at this moment, it may cause serious burning. After temperature is decreased, operation will be conducted as per stipulated steps.

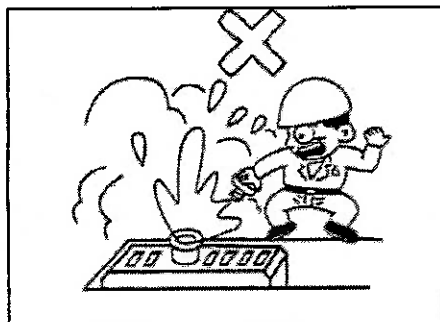

2. Before taking out the cover of the radiator, the engine will be closed. After the radiator is cooled, the cover will be opened slowly, internal high pressure gas will be released and the cover will be removed.

### **Driving and operating (working) on public road**

Operators of the vehicle are also considered as road users. Therefore, you need know and must abide by existing traffic rules.

You need remember that driving speed of the vehicle driven by you is slow and vehicle body is wide and large compared with other vehicles, therefore, it may cause traffic jam. It is very important to remember this point. What's more, you need also pay attention to vehicles behind you and it is prohibited to pass.

SMV plate (slow vehicle plate) can be used. It shall be placed in the position that is easily seen, but not placed on rear window or other windows; it is 0.6m to 1.8m higher than the ground (2ft-6ft) (measured from the bottom of the plate).

1. Driving on highway:
  - a) Accessory device shall be emptied and placed at transfer position (30cm -40cm above the ground, namely 12ft-16ft). What's more, it will be completely reversed. The front end of cargo boom of materials must be marked with red flag. As the machine has working device, there is barrier in the front. Meanwhile, weight is centralized on the front wheel when loading cargos. When driving on the road, special attentions will be paid to front and rear stability of the machine.
  - b) All working lights and warning lights shall be turned off.
  - c) Danger warning scintillator cannot be used.
  - d) Accessory devices and buckets shielding sight line cannot be used to guarantee large accessory device or bucket will not shield the driving light. Enough lighting must be available in the area in the front of the equipment in accordance with traffic rules.
2. Operating on highway (working)
  - a) When considering vehicle speed and busyness degree as well as local situation, road sign, restricted traffic arrangement and other safety equipment must be used.
  - b) When moving equipment with suspended load, observation must be conducted. If necessary, you can seek help from signal personnel.
  - c) Utilization of warning light



- It is used on vehicle when conducting road maintenance work.
  - It is used on auxiliary or connected equipment, when it is wider than the vehicle body.
  - It is used when bringing barrier or danger to other vehicles.
  - When working on traffic lane or near traffic lane
- d) Observe whether there is flog, dust or smoke that will cause vision barrier or not.
  - e) Know working site in advance, observe road situation to confirm whether there is hole, barrier, sludge, ice and snow or not.
  - f) Completely understand various operation requirements to guarantee meanings of various signal flags, signals and signs.

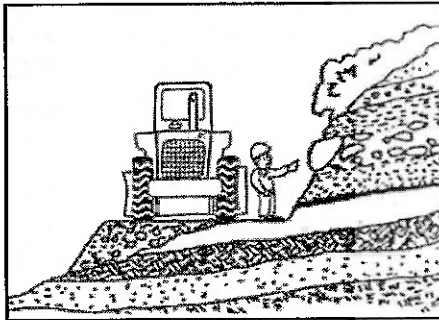

### Prevent injury or cutoff

1. Don't enter or place hand, arm or any other part of the body among movable parts, such as between working device and oil cylinder, between vehicle body and working device and at hinge joints of front and rear frames. With movement of working device, space at the link mechanism will be increased or decreased. If you are close to it, it may cause serious accident or personal injury. If you need to enter among moving parts of the machine, you must close the engine and lock the working device.
2. When working below the machine, the equipment or accessories will be correctly supported. You cannot lean against hydraulic oil cylinder to support. If the control mechanism is moving or hydraulic pipeline leaks, the accessory will fall to cause danger.
3. Unless otherwise stipulated in the manual, any regulation cannot be conducted when the machine is operating or the engine is started.
4. All rotating and moving components will be avoided.
5. You will guarantee fan blade of the engine does not have sundries. Fan blade will throw tools and sundries fallen or pushed into it away or cut off.
6. It is very dangerous to check and maintain when the engine is started, which is prohibited in principle.

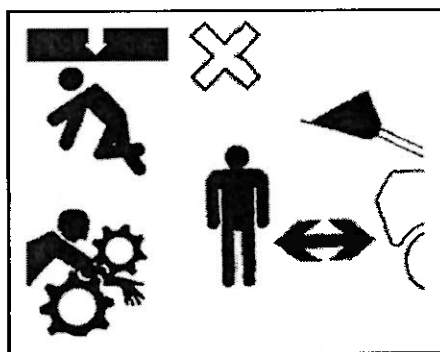
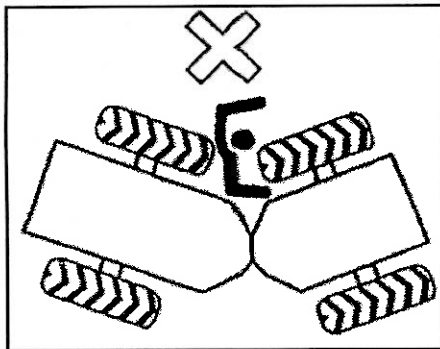

## **Instructions for using FOPS&ROPS (falling object protection system or rolling over protection system)**

Rolling over protection system ROPS and falling object protection system FOPS of products of Shandong Lingong Construction Machinery Co., Ltd. are installed outside of the framework of the cab. Installation of FOPS&ROPS is to prevent heavy object in the top from falling when the machine is working and protect operators once the machine is rolled over. ROPS device can not only support load when the machine is rolling over, but also can absorb impact energy. Attentions will be paid when using:

1. If the machine is damaged due to object falling or rolling over, its strength will be reduced, which will not comply with its normal protection functions. You shall contact Shandong Lingong Construction Machinery Co., Ltd. or its designated distributor to obtain new ROPS or FOPS structure under this situation and you cannot repair on your own.
2. Design requirement of the cab complies with protection requirement for falling object. The weight of the falling object is consistent with the testing method of "FOPS".
3. Even if ROPS has been installed, operators can obtain effective protection only when they have tied safety belts. Operators must tie safety belt when operating the machine. Even if they don't discover abnormality, the safety belt will be replaced every three years.
4. It is strictly prohibited to arbitrarily drill and electrically weld inside and outside of ROPS to avoid damaging or reducing strength of ROPS.
5. The cab can protect operators of the loader. It complies with requirements of "ROPS" rolling over protection structure as per testing standard. Therefore, if the loader encounters rolling over accident, the injury can be reduced by abiding by the following instructions:
  - a) Solidly hold the steering wheel;
  - b) Tilt the body;
  - c) Use feet to stake the bottom plate of the cab;
  - d) It is prohibited to jump off from the vehicle.



**Attention: if "ROPS" rolling over protection structure is deformed or damaged due to some reasons or accident impact, new "ROPS" rolling over protection structure must be replaced. You can contact distributor of Shandong Lingong that is the closest to you for obtaining this equipment.**

### Diethyl ether (if your machine is equipped with diethyl ether cold starting device)

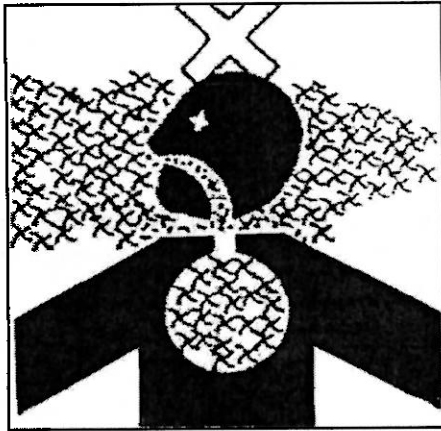

1. Diethyl ether is toxic and flammable substance.
2. Person will be injured if absorbing diethyl ether vapor or skin usually contacts diethyl ether.
3. Place where diethyl ether is used shall have good ventilating conditions.
4. Smoke is prohibited when replacing diethyl ether.
5. Attention will be paid to fire protection when using diethyl ether.
6. Diethyl ether cannot be stored in living area or stored in the cab.
7. The diethyl ether cylinder cannot be placed in place with direct sunshine or place where temperature is more than 39°C(102F).
8. Waste diethyl ether cylinder will be placed in safe place. You cannot punch a hole or conduct barbecue on it.
9. The diethyl ether cylinder will be placed in the place that is far away from working personnel.

### Prevent danger of asbestos dust

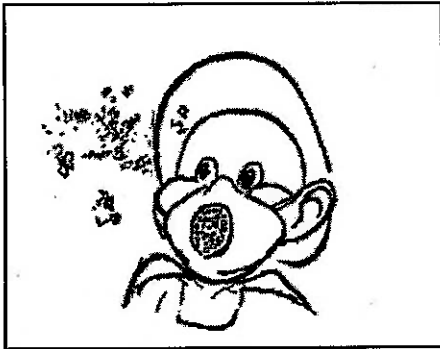

1. It is harmful for health to absorb asbestos dust.
2. Products of Shandong Lingong don't use asbestos. If you need to dispose materials containing asbestos fiber, you will abide by the following rules:
3. Compressed air cannot be used when cleaning.
4. Water will be used to clean so that dust will submerge.
5. If air contains asbestos dust, it is dangerous. The machine shall be operated at the uptake if possible.
6. If necessary, qualified mask can be used.

### Instructions for working machines and tools

1. When installing and using standby working machines and tools, you need read operation manuals of relevant working machines and tools and information related to working machines and tools.
2. You cannot use working machines and tools that are not authorized by Shandong Lingong Construction Machinery Co., Ltd. or distributors designated by Shandong Lingong Construction Machinery Co., Ltd. Utilization of working machines and tools that are not authorized may cause safety problem and is not favorable for normal operation of the machine and will affect lifetime.

3. Shandong Lingong Construction Machinery Co., Ltd. will not be responsible for injury, accident and machine damage as you use unauthorized working machines and tools.

### Safe starting

#### Before starting the machine

Safety of the working site

1. Before starting the machine, you will carefully check whether there is any abnormal situation that may cause danger in the surrounding or not.
2. You will check terrain, soil quality and ground condition of the construction site and confirm the best and the safest working method. Before starting working, you shall level and compact the ground. If the sandy dust on the construction site is heavy, watering shall be conducted before working.
3. When operating on highway, full-time personnel shall command traffic. In addition, fence will be set and sign of "No entry" will be pasted to guarantee safety of pedestrian and vehicle.
4. You shall contact competent department to confirm positions of embedded facilities for places where there are embedded facilities such as water pipe, gas pipe and high voltage cable pipelines. These facilities cannot be damaged to guarantee safety of construction.
5. When operating in water or bog area or passing embankment, you will check ground condition, water depth and water flow speed at first to guarantee water depth is not more than allowable water depth. The bottom of driving axle housing cannot be immersed into water. After working is completed, you will clean and check filler of lubricating oil. Forging depth is shown in "P84 requirements for working environment".
6. If working in the indoor, you must guarantee that there is effective ventilation.

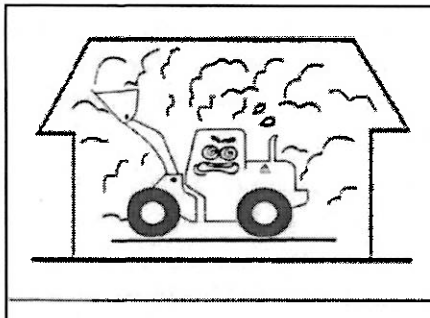

Check before starting the engine

1. The machine will be carefully checked before daily working. If discovering any abnormality, you will immediately report to the management personnel and start to work after removing abnormal situation. If the loader is under good condition, various faults that will cause accident shall be removed in advance.
2. You will conduct daily maintenance. If it is in the winter, you will guarantee freezing point of coolants much lower than cold weather and lubricating oil is



applicable to being used in the winter.

3. You will check whether there is flammable substance such as wood chip, leave or paper surrounding the engine and storage battery or not and remove it to prevent fire disaster.
4. The machine will be checked to confirm whether there is oil leakage, water leakage, loose bolt, abnormal sound or loss or damage of component or not.
5. Floor of the cab, rearview mirror, control handle, pedal and handrail will be checked to confirm whether oil dirt, lubricating grease, snow or other dirt is on them or not. If having, it will be immediately removed.
6. Liquid level of cooling solution, oil level of fuel oil and oil level of engine sump will be checked to confirm whether they are normal or not. Air filter will be checked to confirm whether it is blocked or not.
7. Seat of operator will be adjusted to the position where it is convenient for operation in accordance with "P92 seat adjustment". Seat safety belt and fixation position of safety belt will be checked to confirm whether they are damaged or not. Safety belt must be replaced after it has been used for three years.
8. Various instruments will be checked to confirm whether they work normally or not. Parking position of joy stick (or control handle) will be checked.
9. All dirt on window glasses and all lights of the cab will be removed to guarantee good visibility.
10. The rearview mirror will be adjusted to suitable position to guarantee operators have good view. If glass of the rearview mirror is damaged, it shall be timely replaced with new one.
11. Component or tool cannot be placed or left surrounding seat of operator. As vibration will be generated when running or working, these objects may fall off and damage the control handle or switch; or make the control handle of the working device move so that the working device is started, which will cause accident.
12. All lighting and signal lights will be checked to confirm whether they are normal or not. If check result has any abnormal situation, they shall be repaired.
13. Locking rod of rear and front frames will be checked to confirm whether it has been separated from locking or not.
14. Oil grease on handrail and pedal and sludge and fine sand on shoes will be removed to avoid slipping and affecting operation when boarding the vehicle.

15. The tyre will be checked to confirm whether it is worn out or damaged or not. In addition, bolt and nut will be checked to confirm whether they are loosened or not. Special attention will be paid to check of rim nut. If discovering any abnormality, you need timely repair or replace damaged part.

When the engine is starting

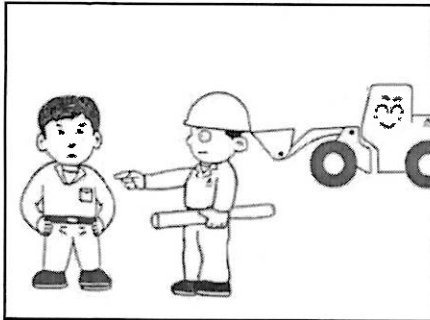

1. Before boarding the machine, you will conduct patrol check for your machine again and check whether there is person or barrier on the machine, below the machine or in surrounding area. Attention will be paid to confirming whether there is any person in the working area or not. If there is any person, you will ask them to leave.

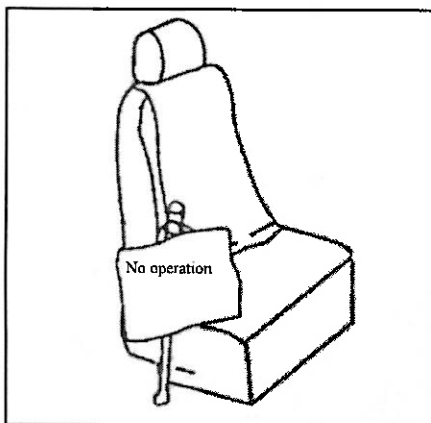

2. If control handle of the working device or control handle of the transmission is equipped with the warning label of "don't operate", it is prohibited to start the engine.
3. You need always sit on the seat of operator, tie button-type safety belt or three-point type safety belt.
4. Hands of the driver will be kept far away from part with risk of being squeezed such as cover, window and door.
5. Door shall be closed tightly.
6. Accessory device has been correctly connected and locked through check.
7. You need be familiar with warning device, instrument and control mechanism on the instrument panel.
8. You need guarantee parking brake switch is at the brake position and all control mechanisms are in the neutral position.
9. You need honk for warning.
10. The engine will be started. Operation for starting the engine is shown in "P126 engine starting".
11. The engine can only be started in the cab. It is strictly prohibited to give short circuit to starting motor to start the engine, which will damage electrical system of the machine via bypass starting system. What's worse, this operation is very dangerous.
12. When using diethyl ether cooling starter, you shall read the specification in advance. Diethyl ether is flammable substance, and attention will be paid to fire protection.



13. If the engine has been equipped with plug preheater, it is prohibited to use diethyl ether.

Check after starting the engine

1. The following check shall be conducted after starting the engine and before operating the machine to guarantee there is not potential safety hazard.
2. When checking, it must be conducted in a vast place without barrier and no person is close to the machine.
3. Check will be conducted to confirm whether there is abnormal sound or abnormal vibration when the engine is operating. If having, the machine may have fault. You shall immediately report to the management personnel and start to operate after removing abnormal situation.
4. Speed control of the engine will be tested under neutral position.
5. Instrument, apparatus and warning light will be observed to guarantee they can normally work and are within designated working range.
6. Gear control mechanism will be operated to guarantee front, middle and rear gears of the machine are accurate and guarantee all control handles can be operated flexibly.
7. Foot brake valve and accelerator operating valve will be tested in accordance with operation instruction and left and right steering will be tested under low speed to confirm whether they are flexible or not.
8. Before the machine driving, you will guarantee parking brake switch is under the position of brake cancellation.

## Safe driving

### Acoustic signal alarming

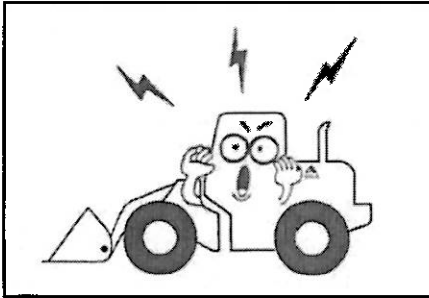

1. When danger alarming is sent to other road users who drive towards the road and leave the road as the machine cannot work or works at low speed due to fault, danger alarming signal need be opened.
2. Reversing alarm is in the left-rear corner inside the engine hood. When the loader is reversing, the alarm will be automatically started; if the alarm is damaged, the machine will be operated again after repairing.

### Pay attention to safety of yourself and others

1. For personal safety of every one, good operation habit need be cultivated.
2. Before driving the vehicle, you shall honk to send signal and drive after confirming it is safe.
3. Particular confirmation will be conducted to confirm that there is not person or barrier in the surrounding area.
4. Braking effect will be checked on dry, level and solid pavement.
5. You cannot place your arms and feet on the working device or extend outside of the vehicle.
6. Door need be closed or fixed when driving. Attention will be paid to prevent hands from being squeezed.
7. The height of the working device will be adjusted to the position below pivoted pin of boom that is 400mm to 500mm (16in to 20in) above the ground. The machine will drive on flat ground.
8. You need be focused when operating and cannot in the clouds. You shall pay special attention to driving direction and surrounding personnel and honk for alarming when there is danger.
9. When driving, you shall reliably fix the cab door. The machine cannot be driven when the door leaf is not locked tightly.

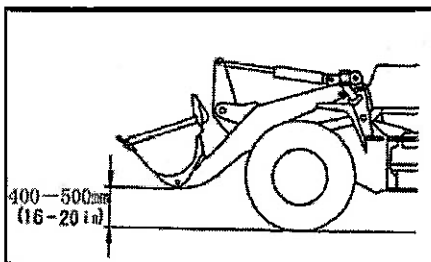
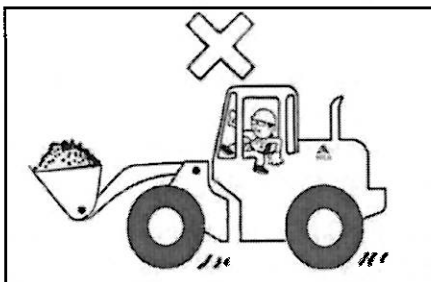



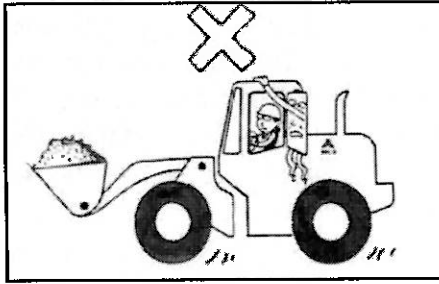

10. It is very dangerous to ride some personnel. No one is allowed in the cab except for operators. Any person cannot sit on the machine body.

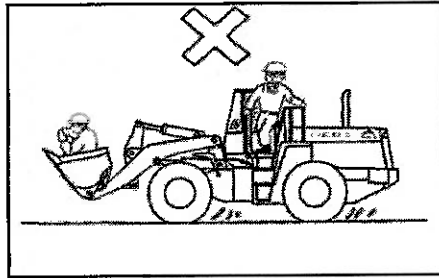

11. It is strictly prohibited to regard the bucket as the working platform or load person.
12. You shall abide by traffic rules when driving on common roads and cannot cause road traffic jam. In particular, you shall rapidly go through railway opening.
13. You need drive to the road side and need given in other vehicles and keep suitable vehicle space.
14. If the engine is closed when driving, you shall immediately brake and stop the machine. Accessory device has falling danger at this moment. It is strictly prohibited that any personnel stand close the machine or enter in the scope of the working device, otherwise, it may cause accident and even fatal accident.

 **Warning**

- **The steering gear cannot work after the engine is closed.**
- **Emergency brake may cause personal injury!**
- **It is very dangerous to conduct conversion of forward gear and reserving gear when driving at high speed, operation is prohibited.**

**Load transportation**

1. Operators of the loader will be responsible for loader load when working on highway or working on the site.
  - a) The danger of load falling is prohibited when operating.
  - b) Load with obvious danger cannot be loaded.

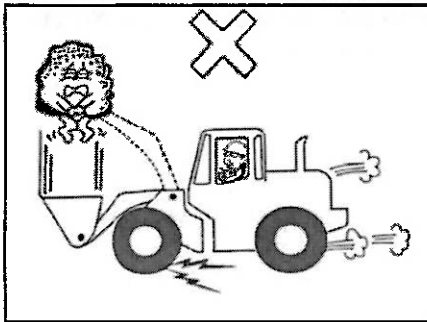

2. It is very dangerous to lift bucket with materials for transportation. When transporting with full load, suitable speed shall be selected and the bucket shall be lowered down at the position of reversed stop dog. The machine will operate at suitable height (400 mm-500mm), which can reduce gravity center and guarantee stability of the vehicle.
3. Load capacity cannot exceed rated bearing capacity of the machine. You shall confirm that load of the machine is within the allowable scope to avoid overload. In addition, you will pay close attention to influence of different distances on gravity center and different accessory devices. Shandong Lingong Construction Machinery Co., Ltd. will not undertake any liability for damage of personnel or machine due to overload use.
4. When transporting, emergency driving, emergency brake, emergency turning and driving around are prohibited.
5. It is very dangerous to make working device stop and descend at high speed. If the working device stops or descends at high speed, loads on the vehicle may be thrown away or vehicle may roll over. This operation shall be avoided.

**Speeding is strictly prohibited.**

1. You need be very familiar with performances of the vehicle and determine suitable driving speed according to actual situation of the working site. Meanwhile, you will determine machinery operation route and working method that need be known by relevant operators.
2. You need operate at low speed so that the vehicle is under controlled state all the time.
3. When driving on rough and smooth pavement or slope, high-speed driving, turning and emergency brake will be avoided.
4. It may be difficult to control the steering wheel in places that have not been collated or uneven pavement or pavement where there are sundries. Improper control may cause rolling over accident. Therefore, the speed must be reduced when driving.
5. The engine will be operated stably. It is strictly prohibited to drive at high speed when steering.

### Guarantee good visibility

1. The speed will be reduced or you need honk to tell other vehicles if necessary or you need ask some personnel to guide to avoid aimless operation in places where front vision is not good or narrow road intersection.
2. Dust, fog and storm will affect visibility. When the visibility is reduced, you need decrease your speed. Work need be stopped if view is not good. Work will be re-started when weather gets better.
3. Loader is special vehicle. You shall be very careful when descending, lifting, forwarding, reversing and changing gear if loading and unloading long object and view is bad. Meanwhile, any personnel are not allowed to enter the working scope or full-time personnel will be responsible for guidance.

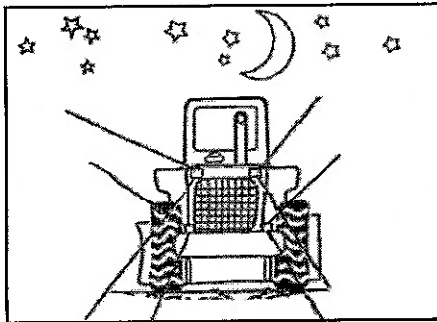

4. Misconception is easily generated for distance and ground height in the evening. Therefore, you must maintain lighting and drive at suitable speed.
5. When working in dark place, front headlight, rear headlight and work light will be lit.

### Attention will be paid to barriers

1. When vehicle is driving or is making turn in places with barriers (ceiling of buildings or upper part of gate), vehicle cannot collide with loaded object.
2. When driving or steering in narrow place, attention will be paid to safety of the surrounding area and speed will be reduced to confirm whether there is barrier in the surrounding area or not.
3. When the pavement condition is not good, loading and unloading are not stable, therefore, you shall be cautious about operation to prevent loaded object from losing stability.

### Attention when driving in severe environment

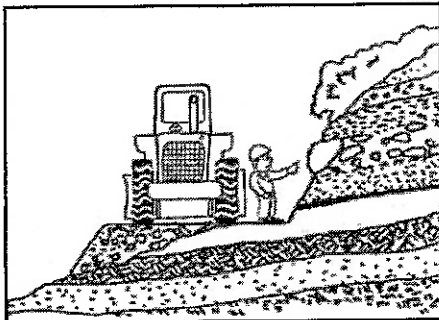

1. Close attention will be paid to safety when driving and working in severe environment. Independent operation cannot be conducted in dangerous place. Advance investigation shall be conducted for condition of driving pavement, bridge strength, terrain of working site and state of geology. Work shall be conducted under good ground conditions.
2. When driving in damp place or loose and soft place, you shall pay attention to wheel submergence and braking effect.

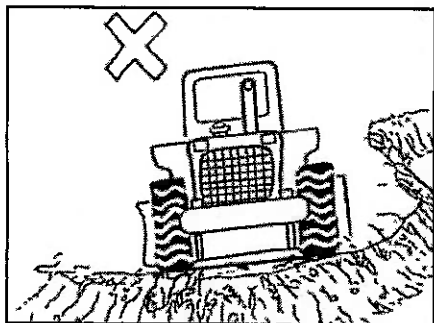

3. When working in the water or bog area, the bottom of driving axle housing cannot be immersed into water. After the vehicle is immersed into water or is rained, the loader will be driven at low speed, braking pedal will be lightly stamped as per certain interval and the brake need be kept dry.
4. Soil stacked on the ground and soil near ditch are loose, which may be collapsed under weight of the machine or vibration of the machine so that the machine is rolled over.
5. Vehicle cannot be operated near suspended object or deep gully. These places may be collapsed due to weight of the machine or vibration of the machine, which will cause machine rollover and personal casualty.
6. When there is risk of rock falling in working place or the machine may be rolled over, falling object protection system or rolling over protection system shall be installed.
7. When continuous operation is conducted in rainy days, operation shall be conducted carefully as working environment will change. There is debris on the site after earthquake and blasting, you shall be careful when working.
8. When driving on snowy road, tyre chain will be installed, vehicle will be driven at low speed and sudden starting, parking or turning will be avoided; what's worse, sudden brake cannot be conducted. Interrupted brake shall be conducted. If necessary, the bucket will be descended to the ground to stop the machine.
9. When working on snowy ground, adhesive force of the ground will be greatly changed due to accumulated snow. Therefore, load capacity will be correspondingly reduced to prevent the machine from slipping.
10. When executing the task for removing snow, as the shoulder cannot be seen or other objects cannot be seen, you shall be very careful.

### **Driving safely on slope**

1. When driving on abrupt slope, dam or inclined slope, improper operation may cause rollover or slipping. You shall be very careful.
2. When you are driving along the longitudinal direction on slope, dam or inclined slope, the bucket will be closed to the ground, which is about 200 to 300mm above the ground. The bucket shall be rapidly descended to the ground under emergency situation to help vehicle to be parked or to prevent rolling over.

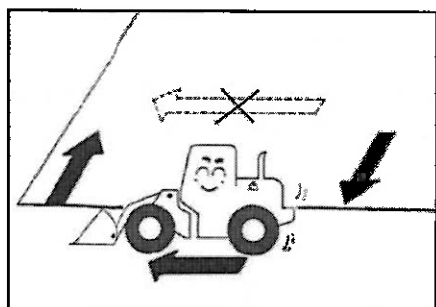

3. You cannot make turn on slope and cannot drive along horizontal direction or change direction on the slope as there is danger of rolling over. You can conduct these operations after driving to flat ground.
4. Steering is prohibited in inclined slope. Steering can be conducted only when the vehicle arrives on flat ground. When working on hilltop, dam or inclined slope, speed shall be reduced and small angle steering shall be adopted.
5. If possible, you had better drive up and down the slope rather than small alley or sidewalk.
6. Suitable gear will be selected when going down the slope. You cannot change the gear in the process of leaving the slope.
7. When driving on the slope, as the gravity center of the vehicle is moved to the front wheel or rear wheel, you will be cautious about operation and cannot use emergency brake.
8. If driving to the slope with full load: gear I will be used for driving; you will go forward when going up the slope and drive backwards when going down the slope; turning is prohibited.
9. If you implement braking when going down the slope, you cannot place the control handle of the transmission at the neutral position.
10. You shall drive slowly when going down the slope. It is strictly prohibited that the engine is closed.
11. If the engine is closed on inclined slope (gradient shall be less than  $15^{\circ}$ ), you need immediately stamp the braking pedal and place the bucket on the ground and press the parking brake switch so that the vehicle is under parking brake state. The control handle of the transmission will be at the neutral position and the engine will be re-started.
12. When loading, the bucket will be faced to the slope direction. Namely, the vehicle will move forward when going up the slope and move backward when going down the slope.

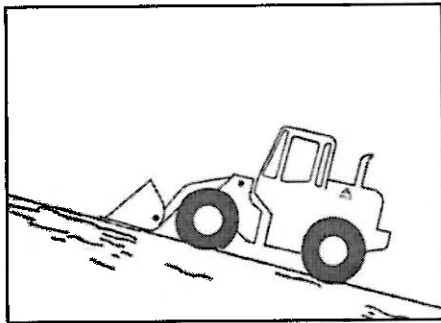

## Traction

 **Warning**

**Wrong traction method or wrong steel wire rope may cause injury or death.**

1. Operation will be conducted in accordance with instruction in the “P108 traction operation”. Other wrong traction methods may cause danger.
2. Leather glove will be worn when disposing steel wire rope.
3. When making preparation for dragging together with other workers, signal must be determined before working.
4. It is dangerous to drag one set of machine on inclined slope. You shall select a place whose gradient is flat to the largest extent.
5. If the machine with fault is dragged by another machine, used steel wire rope must be adequate to bear weight of the dragged machine. Used steel wire rope cannot have cutoff piled yarn, twisted or shortened diameter.
6. When connecting to the machine that need be dragged, any person is not allowed to stand between the traction machine and dragged machine.
7. You cannot stride your feet to stand on dragging wire rope or steel wire rope.
8. Hook of dragged machine and dragging part of the machine are in the same straight line. In addition, you will guarantee they are installed at proper positions.
9. If the engine of the machine with fault cannot be started or braking system has fault, you need contact distributor designated by Shandong Lingong Construction Machinery Co., Ltd. for repair.

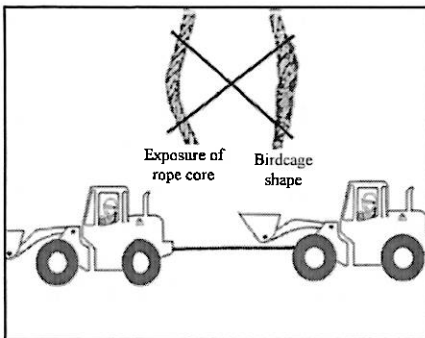

## Safe operation

### Keep good operation habit

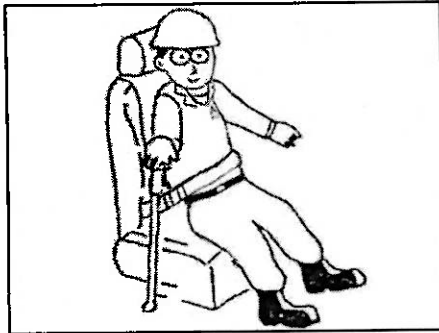

1. Seat of operator will be regulated and steering wheel will be regulated (if the loader has this function).
2. You shall sit on the seat and tie safety belt when working. The vehicle shall be under the controlled state all the time.
3. Casement window will be cleaned before operation to guarantee clear view.
4. The control handle of the working device will be accurately operated to avoid maloperation.
5. You need carefully observe and listen to fault. If there is fault, you shall immediately alarm. You cannot repair components under working state.
6. Vibration occurred in the operation process (shake) may be harmful for operators. Vibration can be reduced by:
  - a) Regulating seat and tightening safety belt.
  - b) Selecting the flattest operation face for loader (if necessary, the ground will be leveled).
  - c) Adjusting your speed.

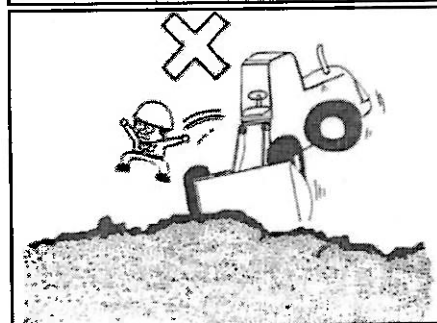
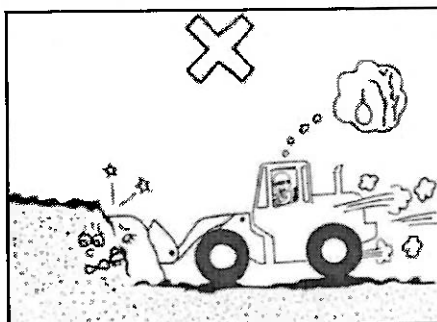
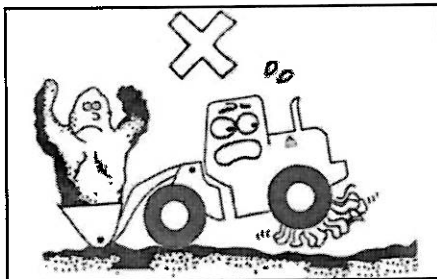

7. Load cannot exceed its bearing capacity. It is extremely dangerous to conduct operation beyond vehicle performance. Therefore, you shall confirm load weight at first to avoid overload.
8. Shandong Lingong Construction Machinery will not undertake any liability for injury of machine or personnel due to overload use.
9. High-speed rushing is a kind of very dangerous and wrong operation method, which will not only damage the vehicle and injure operators, but also will damage cargos.
10. It is strictly prohibited to open the door in the process of driving and working.
11. Vehicle will keep perpendicularity for loaded object. If operation is conducted along the oblique direction, it will not only aggravate damage of steering oil cylinder and differential mechanism, but also make the vehicle lose balance to endanger safety. This operation cannot be conducted.

12. You shall walk in front of the loaded object to confirm surrounding condition and commence working.
13. You shall check site clearing situation before conducting operation in narrow areas such as tunnel, overhead bridge and garage. You cannot damage working device in the operation process.
14. Materials shall be loaded following the wind in heavy windy days.
15. Operation must be cautiously conducted when the boom is lifted to the highest height. Loading operation by lifting the working device to the highest height may make the vehicle unstable. Therefore, movement of the vehicle will be slow and forerake of the bucket shall be conducted slowly.

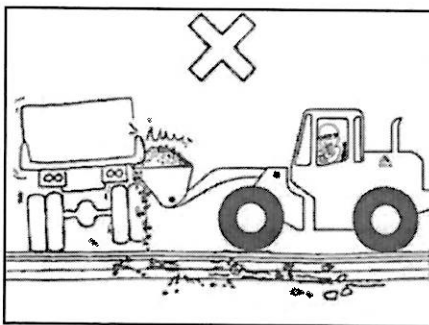

16. When loading objects to truck or tilting cart, you shall prevent bucket from colliding with truck or tilting cart. Personnel cannot stand below the bucket and bucket cannot place above the cab of the truck.

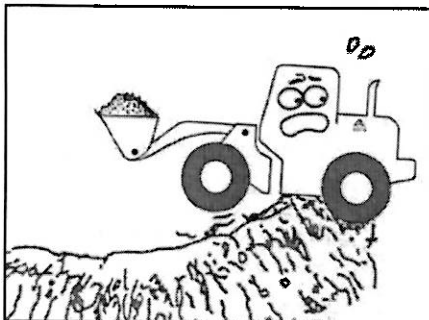

17. You shall carefully observe the rear of the vehicle before reversing.

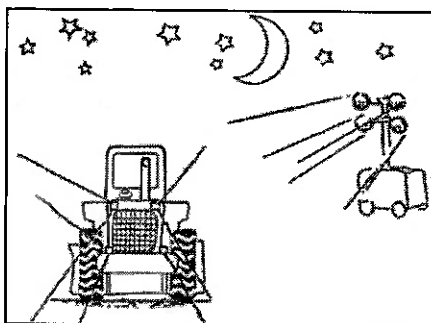

18. Operation shall be stopped when the visibility is reduced due to smoke, fog and dust. If lighting is not enough on the working site, lighting equipment must be installed.
  - a) Attention will be paid to the following key points when working in the evening:
  - b) Suitable lighting equipment has been installed through confirmation;
  - c) Work light on the loader works normally.
  - d) It is not easy to know height and distance of object when working in the evening.
  - e) You shall be cautious when working in the evening and you shall usually observe surrounding situation and check vehicle by closing the machine.



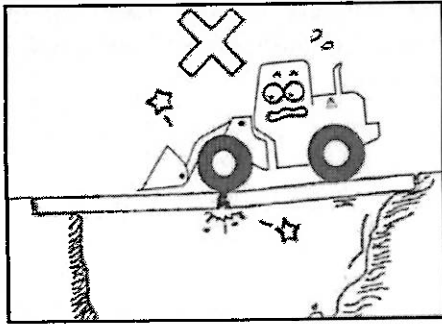

19. Before crossing bridge or other buildings, you shall guarantee it is strong enough for vehicle to cross.

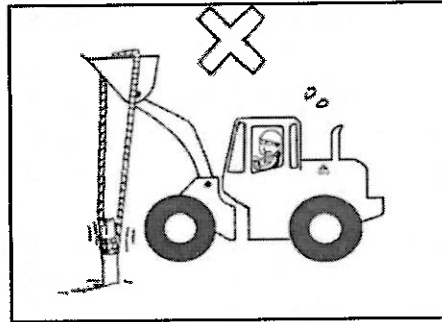

20. Vehicle cannot be used for other purposes beyond professional operation. Use of the head end or a part of working device for lifting, seizing, moving or pushing or use of working device for traction operation may damage the machine or cause accident.

### Working in dangerous area

#### Pay attention to the surrounding area

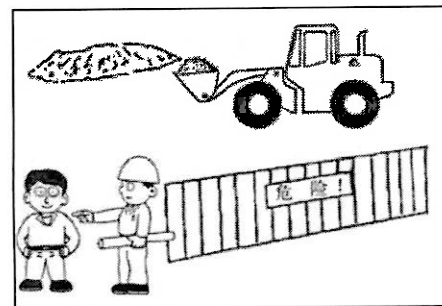

1. Operators of the loader must be responsible for working area of the loader.
2. Unconcerned person cannot enter the working scope. As the working device is for lifting, descending, left rotation, right rotation, moving forward and backward, the area surrounding the working device (bottom, front, rear, inside and two sides) is dangerous, no unconcerned person is allowed to enter.
3. Personnel cannot enter or stay in dangerous area (namely, the scope that is at least 7m (23ft) away from all directions of the loader under operation). One operator can stay in the dangerous area, but it need observe and can operate the loader when it can be seen or its specific position has been specified.
4. It is prohibited that personnel stand below the boom that has been lifted or walk below it, unless the boom has adopted safety measures or has been supported.
5. When working on the road side or place where cliff may be collapsed, methods guaranteeing safety must be adopted and monitoring personnel must be assigned and operators must abide by its command.
6. When throwing sandy soil or rock away from height, you shall pay enough attention to safety of falling place.
7. When loaded object is thrown away from cliff or vehicle reaches in the top of the inclined slope, load will be suddenly decreased, and vehicle speed will be suddenly increased. Therefore, speed must be reduced in advance.

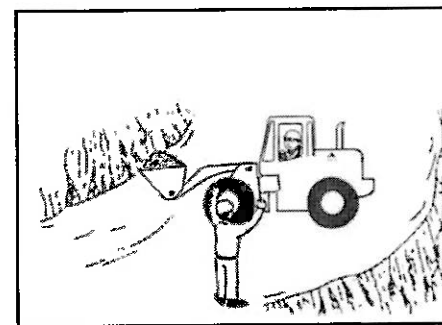

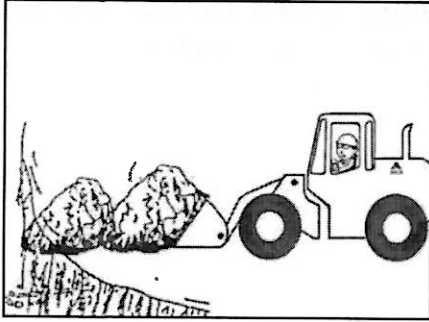

8. When banking or bulldozing or soil dumping, one stack will be dumped and then the second stack will be used to push the first stack.

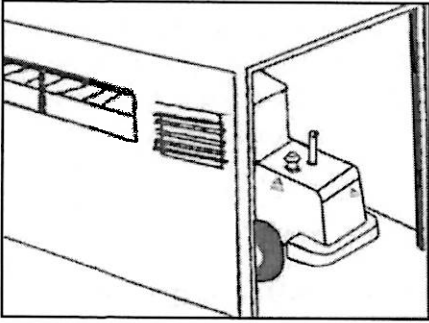

Enough ventilation will be guaranteed when working in closed space

1. If operation must be conducted or fuel oil must be disposed, component or paint must be cleaned in closed or place with bad ventilation, door and window must be opened to guarantee enough ventilation to prevent personal injury. If enough ventilation cannot be provided by opening door and window, ventilating equipment such as fan shall be installed.

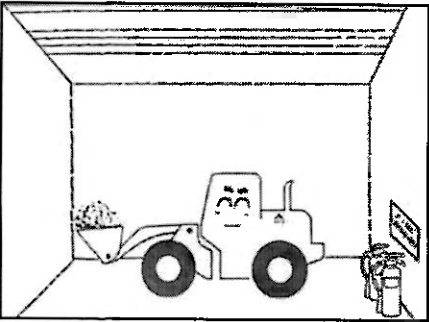

2. When working in closed space, fire extinguisher shall be configured at first. In addition, you shall remember its storage position and know utilization methods.

Working in dangerous area

 **Warning**

**When working, other work personnel cannot be close to dangerous area.**

1. Working in areas with pipelines, power transmission line or cable
  - a) The employer has liability to understand positions of gas pipeline, water pipe, sewage pipe or power transmission line or cable on the construction site and make marks. Then, it will notify operators about relevant situations. If this work has not been conducted, it will undertake legal liability. If necessary, it shall contact local authority and (or) telecommunications and electric power departments about map and suggestions.
  - b) Power transmission line and cables must be protected in proper way to avoid damage. What's more, it shall obtain information where gas and water can be closed. Once pipeline is broken, it can rapidly close them.
  - c) If gas discharged by the silencer is discharged to flammable substances, or exhaust pipe is close to flammable substances, it is easy to cause fire disaster. Therefore, special attentions will be paid to places with oil grease, raw cotton, paper, withered grass and chemical products.

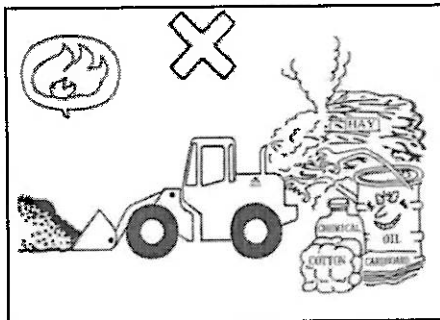

 **Attention: if excavation operation must be conducted in places near cable, pipeline or overhead line, manual excavation may be required.**

2. Working in area near high voltage cable

	Voltage	Minimum safe distance	
Low voltage	100~200V	2m	7ft
	6,600V	2m	7 ft
High voltage	22,000V	3m	10 ft
	66,000V	4m	14 ft
	154,000V	5m	17ft
	187,000V	6m	20 ft
	275,000V	7m	23 ft
	500,000V	11m	36 ft

When working near high voltage overhead transmission line, you will carefully observe as electric arc may damage loader and injure operators in places that are very far away from power transmission line. Attention will be paid to the following matters:

- a) The safe distance shown in the below table will be kept between the machine and cable.



**Attention: this safe distance is also applicable to any load. Therefore, lifting positioning of boom (lifting height) must be adjusted.**

- b) When the machine may contact cable on the construction site, you shall query voltage of cable from electrical power company and consult about relevant existing laws and regulations to confirm whether action is feasible or not before operation.
- c) The machine cannot contact overhead cables. It may cause electric shock even if it is close to high voltage cable.
- d) Rubber boots will be worn and rubber glove will be worn. One piece of rubber pad will be placed on the seat of operator. In addition, any exposed part of your body can not contact metal chassis.
- e) One signal personnel will be designated. If the machine is too close to cable, it will send alarming signal.
- f) Once the working device contacts cable, operators cannot leave the cab and cannot move on the seat and cannot contact the machine until others on the ground have safely cut off power supply.
- g) When working near the high voltage cable, any personnel cannot be close to the machine.

### 3. Operating under the ground

Special equipment such as engine through certification is required in European countries and countries in European economic area. You can contact the distributor who is the closest to you to discuss about this issue.

### 4. Working in restricted area

- a) Check will be conducted to confirm whether there is enough space for the loader and load to use or not.
- b) Slow movement
- c) If the passageway is too narrow and two vehicles cannot pass parallelly, they need rive in the center of the entrance and exit.

### 5. Working near dangerous area

- a) You will carefully observe when working in places with danger sign.
- b) Operation cannot be conducted near the embankment and edge of the slope.

### Operation in cold weather

1. If the temperature is too low, the engine will be difficultly started; the radiator may be frozen. Therefore, the following points shall be achieved:
  - a) Fuel oil, hydraulic oil and lubricating oil with low viscosity will be used. Antifreeze will be filled. Specific oil is shown in the "P184 table of oil selection".
  - b) Instructions for using antifreeze:
    - Antifreeze containing methanal, ethanol and propyl alcohol cannot be used.
    - Any water seal agent cannot be used.
    - Different antifreezes cannot be mixed.
    - Antifreeze will be replaced in accordance with requirements, which is shown in the "P159 cooling system".
2. Requirements for using storage battery
  - a) When surrounding temperature is decreased, the capacity of the storage battery will also be decreased. If the charging rate of the storage battery is low, electrolyte may be frozen. You shall maintain the charging rate close to 100% as much as possible and achieve thermal insulation. Therefore, the engine can be easily started in the following day.

 <b>Attention</b>
---

<b>Oil quantity must be checked before operation or 15 minutes after the engine is closed.</b>
--

- b) If the storage battery is frozen, it cannot be charged or the engine cannot be started. The storage battery shall be dismantled and placed into greenhouse or warm water (don't allow water to enter into the storage battery). Temperature will be slowly increased to 15°C, otherwise, it may explode.
  - c) Storage battery that can be resistant to extreme coldness shall be used in extremely cold regions.
3. Instructions after daily work has been completed

To prevent machine from frozen to affect vehicle operation of the following day, the following work will be conducted:

- a) Sludge and water on the machine will be completely removed to prevent sludge, water or snow from entering into sealing place and being frozen and damaging sealing element.
- b) The vehicle will be parked on dry hard ground. If it is not possible, the vehicle will be parked on wooden plate. Use of wooden plate can prevent vehicle from being frozen on the ground so that the vehicle can be driven in the following day.
- c) The capacity of the storage battery under low temperature will be obviously decreased, the storage battery shall be covered or it shall be transferred to warm place and reassembled when working in the following day.

4. After cold weather is over

After it becomes warm, corresponding parts shall be changed to engine oil, fuel oil and hydraulic oil that are adapted to ambient temperature.

### **Safe parking**

#### **Attention will be paid to safety of yourself and others**

1. Parking position of the vehicle will be flat ground. In addition, working device will be descended to the ground for placing horizontally.
2. The vehicle cannot be parked on inclined slope. If necessary, the slope of the inclined slope must be less than 20%. Meanwhile, the wedge block shall be placed below the wheel to prevent machine from moving. Then, the bucket will be descended to the ground.
3. When vehicle breaks down or if need be parked in place with traffic jam, fence, signal, banner or warning light will be placed. In addition, other necessary signals will be placed to guarantee passing vehicles can clearly see the machine. What's more, machine, fence and banner cannot disturb traffic.
4. When parking, materials on the vehicle will be removed. The bucket will be completely descended to the ground, the engine will be closed and rest pressure will be released. The parking brake switch will be pressed and placed at the brake position. Key will be used to lock all equipment and then removed. When getting off the vehicle, you need climb down slowly. You must guarantee three-point contact of handrail and ladder. Jumping off is prohibited.

 **Warning**

**It is strictly prohibited to board the vehicle or get off the vehicle when the vehicle is driving.**

**Instructions in cold region**

1. After operation is completed, water, snow or sludge on the wire, connection peg of wire, switch or sensor as well as covers of these components will be cleared. If these substances have not been cleared, moisture among them will be frozen, which will make the machine break down and cause unexpected accident.
2. Pre-heating operation will be conducted adequately. Before starting to operate the control handle of the working device, if the machine has not been preheated adequately, response of the machine shall be slow, which may cause unexpected accident.
3. The control handle of the working device will be operated to circulate hydraulic oil in the hydraulic system (increase system pressure to system setting pressure, and then release pressure, and oil flows back to the hydraulic oil tank) to heat hydraulic oil, which can guarantee the machine can have good response and prevent breakdown.
4. If the electrolyte of the storage battery has been frozen, the storage battery cannot be charged and other power supply cannot be used to start the engine, as it is danger and it will ignite the storage battery. Operation will be conducted in accordance with "P136 operation in cold weather".

**Safety check and repair**

**Instructions before maintenance**

1. Personnel of machine operation and repair will obtain training and corresponding qualification; personnel who are not related to maintenance and repair work cannot enter working area. If necessary, full-time personnel will be assigned to be on duty. Personnel who are not related to work cannot be close to machine or component.

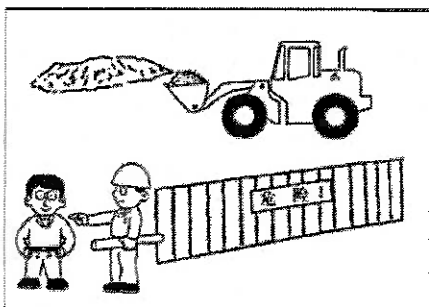

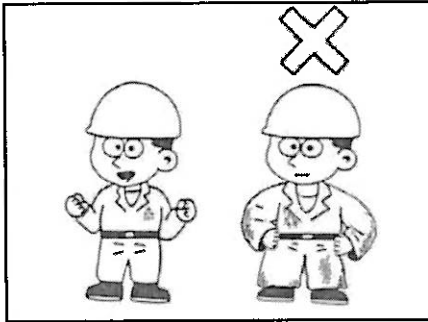

2. Person in charge of operation shall be determined before repairing the vehicle to formulate operation procedures and operate as per steps in the procedure. If it does not know how to operate, it shall seek for help from Shandong Lingong Construction Machinery Co., Ltd.
3. Person in charge of operation shall be determined before repairing the vehicle to formulate operation procedures and operate as per steps in the procedure.
4. Working clothes with tight cuff and trouser les shall be worn. Hard cap, safety glasses, protective shoes and gloves shall be worn. If necessary, qualification respirator and other protective articles through review will be worn too.
5. Correct repair tools will be used and damaged and low-quality tools cannot be used. If tool, lifting device or working methods that are not specified in the manual, the company will not undertake any liability.
6. To prevent personal injury, the working device will be descended to the ground horizontally, the engine will be closed, parking brake switch will be pressed so that the vehicle is under parking brake state and the vehicle will be pegged when repairing; front and rear frames will be fixed with frame locking rod to prevent injuring personnel due to rotation.
7. You will carefully read *Operation and Maintenance Manual* and nameplate and instructions on the vehicle before repair to obtain necessary knowledge and information related to the vehicle. You will strictly abide by instructions on warning sign. If sign is peeling off or polluted, it will be pasted again or cleaned.
8. Before implementing repair work, the identification of "Do not operate" or other similar warning identifications shall be attached to starting switch and instrument panel to prevent others from starting the engine or operating control handle of the working device. Otherwise, it will cause casualty of operators.
9. The working site will be kept clean and neat. When emptying or discharging oil or fuel, pump or flexible pipe will be used and suitable vessel will be used to collect liquid. Splashing will pollute the environment and cause fire disaster or cause personnel to slip. Waste oil and other polluted liquid shall be disposed by the company with special authorization for conducting similar work.
10. Smoke is strictly prohibited when injecting oil or checking storage battery. If necessary, the escutcheon of No smoking shall be set on repair site.





11. Components dismantled from the machine will be placed in a safe place and guarantee components will not fall off. Handrail will be placed surrounding it and the sign of "No entry" will be hanged on it to prevent personnel without consent from entry.
12. Equipment such as strap, sling, ratchet wheel, pulley and ground supporting that used for supporting parts will be checked to confirm it can cope with born stress and complies with existing national provisions. When lifting is required, the front and rear frames must be locked by using frame locking rod. What's more, the loader will lift lifting eye that is used for purpose.
13. If necessary, overhauling and maintenance work will be conducted when the bucket of the boom is lifted and all control handles must be at the neutral position and all necessary oil cylinders of boom and supporting device of rotating bucket oil cylinder will be used to protect working device from falling. In addition, safe joy stick must be solidly placed at locking position and parking brake will be used.
14. Band 2 radio, holding type steering or other similar equipment must be installed by professional personnel with experience, which is because that installation error may interfere with electronic device that is used to control important functions of the vehicle.
15. Even if the loader stops and the engine are closed, pressure vessel, flexible pipe, pipeline and quick-change connector may have pressure. Pressure in pressure pipeline/vessel, part and system will be carefully released to prevent danger when maintaining. Dismantling of these parts shall be conducted by professional personnel through training. Methods for discharging residual pressure include: the level will be smoothly operated for three to four times when ignition switch is at the position of "ON". Air filter on the hydraulic oil tank will be slowly opened for discharging residual pressure in the hydraulic pipelines.
16. When repairing electrical system or conducting electric welding operation on the machine, the cathode of storage battery will be removed to prevent current flow.
17. Protective devices such as protecting wire net of fan, hood and storage battery will be dismantled by using designated tools. When dismantling, the machine will be placed at repair position (refer to P147, after the machine body is cooled, it will be dismantled by using designated tools).

### Working under special situations

1. Gas discharged by the engine can cause pathopoiesia and even lethal of personnel. If the engine is started in closed place, air exhausting device will be used to exhaust gas in the area. If there is not air exhausting device, adequate ventilation will be guaranteed.
2. When operating in area with pollution or danger, the loader must be equipped with special equipment. When operating and repairing the vehicle in these areas, it will comply with local special safety provisions.

### Maintenance work when the frame is lifted

1. When the special jack is used to lift the frame, personnel cannot enter into another side.
2. Before lifting, frame locking rod must be used to lock front and rear frames, control handle is at neutral position and wheel will be pegged from the opposite side. After lifting, pad will be placed below the machine.

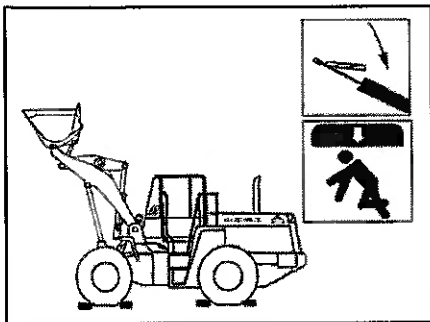

### Working below the machine

1. The machine will stop on solid and flat ground. Before maintenance or repairing below the machine, the working device will be descended to the ground horizontally.
2. The wedge block will be used to fix tyre.
3. It is very dangerous to work below the machine if the tyre is only supported by the working device.
4. Don't work below the machine that is not sufficiently supported.

### Working in the top of the machine

1. When conducting maintenance work in the top of the machine, you will guarantee cleanliness of foothold and there is not barrier and comply with the following instructions to prevent falling.

#### Attention

- Without falling lubricating oil or lubricating grease.
- Tools cannot be placed surrounding the machine.
- The machine will travel stably.

2. Don't jump on or off the machine. When boarding or getting off the machine, you need face to the machine and use ladder and handrail. In addition, three-point contact will be kept (two feet and one hand or two feet and one hand).
3. If necessary, protective equipment will be used.
4. As the top of the engine hood is smooth and dangerous, personnel cannot stand on it.
5. As the top of the tyre is smooth and dangerous, personnel cannot stand on it.

### **Maintenance work when the engine is operating**

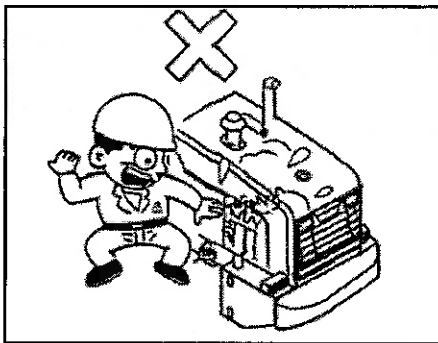

The engine shall be closed before opening the engine hood. Maintenance work cannot be conducted when the engine is operating to prevent injury. If maintenance must be conducted when the engine is operating, the following instructions must be abided by:

1. One operator will be arranged on the seat to guarantee all repair and maintenance personnel can smoothly contact it and prepare to close the engine at any time.
2. High temperature parts including tail pipe and silencer cannot be contacted to prevent burning.
3. When the operation point is close to the rotating component, you shall be very careful as there is the danger that you may be rolled by rotating component.
4. Any control handle cannot be contacted. If the control handle must be operated, signal will be sent to other personnel to warn they need go to safe place.
5. Any tool or any part of the body cannot contact fan blade or belt of the fan. Otherwise, it may cause serious injury.
6. Parts that you don't understand cannot be adjusted.

### **Foreign matter cannot fall inside the machine**

1. When opening the overhaul window or the filler of the oil tank to overhaul, foreign matter that may damage tools (such as nut, bolt, cotton yarn, tool and so on) cannot fall into the machine. If these objects fall into the machine, it may cause machine damage, maloperation and other faults. If any foreign matter falls into the machine, it must be safely taken out from the machine.
2. When overhauling, pocket cannot have any unnecessary tools and components.



## Cleaning

1. Anti-skid shoes will be worn to prevent slipping on damp surface when cleaning the machine. When the machine is flushed with high pressure water, protective clothes will be worn.
2. The machine will be timely cleaned, which can prevent dirt or sludge on the machine from splashing into eyes or avoid slipping and injury dangers when the machine has oil stain.
3. Non-flammable cleaning agent will be used to clean the machine.
4. When cleaning the interior of the machine, the engine shall be closed, the control handle of the working device shall be placed at the neutral position, control handle of the transmission shall be placed at the neutral position and the parking brake switch shall be pressed and at the brake position.
5. Water cannot directly spray to electric elements (such as sensor, electric wire connection peg) or cab. If water enters into electric system, it may cause operation fault or circuit damage.
6. When the filter element is cleared by using compressed air, protective clothes and safety glasses must be worn.

## Heavy object

1. When using the hammer, protective clothes, protective shoes, protective glasses, glove and safety helmet must be worn. In addition, one copper rod will be placed between the hammer and the hammered part.
2. If the hammer is used to hammer hard component such as pin or bearing, fragment may splash into eye and cause injury.
3. Tool and heavy object will be used carefully to prevent falling.

## Welding repair

Electric welding operation will be conducted by welders with corresponding qualification and skills in place where suitable equipment is installed. Electric welding will generate gas, therefore, it may cause fire disaster and electric shock when operating and personnel without qualification cannot operate. The following instructions must be abided by when welding:

1. Protective clothes and recognized respirator must be worn when conducting electric welding operation.
2. Ventilation on the electric welding site must be adequate.

3. All flammable materials will be cleared and fire extinguisher must be installed on the working site.
4. Modification that may affect performances, safety and strength of the vehicle and working device cannot be conducted.
5. Terminal of the storage battery will be disconnected to prevent explosion of the storage battery.
6. Wire terminal on the computer control panel of the transmission will be disconnected to prevent impact current from damaging the computer control panel when conducting electric welding operation; after repair is completed, the wire terminal of computer control panel must be connected in accordance with requirements. Otherwise, the machine cannot be started and driven.
7. Oil paint of the position that need be welded will be removed to prevent generation of hazardous gas.
8. If electric welding is conducted on hydraulic equipment or pipelines or places that are very close to it, it will generate flammable vapor and spark and there is danger of ignition or explosion. Therefore, electric welding cannot be conducted in such places.
9. Splashed spark when welding will directly fall on flexible rubber pipe, wire or pressure pipelines. These pipes may be suddenly broken, electric wire insulation will be damaged. Therefore, they will be covered with fire damper.
10. When conducting electric welding operation in the place near tyre, special attention shall be paid as tyre may be exploded when heated.

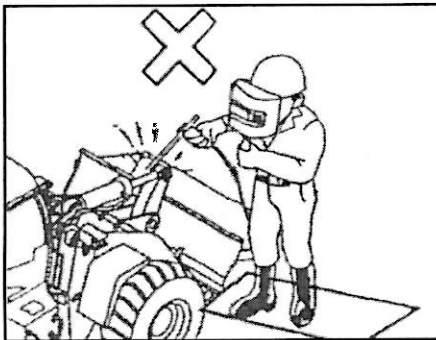

### Overhaul of the cooling system

1. Temperature of hydraulic oil, engine oil and water and oil and water in the radiator is still very high and pressure is still existed when operation is completed just now. Any operation of opening cover of oil tank, cover of radiator, pouring oil or water or replacing filter at this moment may cause serious burning. The above operations can be conducted in accordance with stipulated procedures after the temperature has been decreased.
2. To prevent hot water from erupting, the engine shall be closed to cool down the water and the cover shall be slowly loosened to release pressure. When checking to confirm whether water temperature has been decreased or not, hand can be close to front of the radiator to check air temperature. Hands cannot contact radiator.

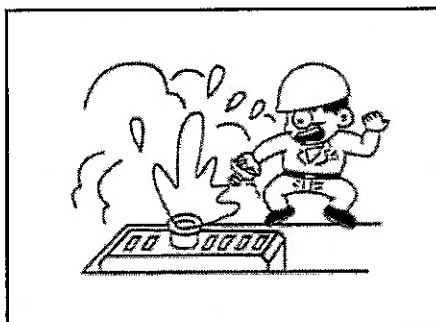

3. To prevent hot oil from erupting, the engine shall be closed to cool down the oil and the cover shall be slowly loosened to release pressure. When checking to confirm whether oil temperature has been decreased or not, hand can be close to hydraulic oil and front of the radiator and torque converter to check air temperature. Hands cannot contact radiator.
4. Don't contact the engine or silencer, tail pipe and relay to avoid burning when heating the vehicle.
5. Water temperature sensor of the engine, oil temperature sensor of torque converter and water pipe of air conditioning cannot be dismantled to avoid burning when heating the vehicle.
6. As the cooling system contains alkaline matter, your skin and eyes cannot contact it.
7. Suitable vessel shall be used to accommodate liquid when replacing cooling solution, engine oil, oil of transmission and components such as filter. Waste liquid disposal is shown in "P69 disposal of dangerous materials and waste materials".
8. When dismantling connecting pipes of air condition compressor, open fire is strictly prohibited. Otherwise, toxic gas will be generated to cause poisoning accident.

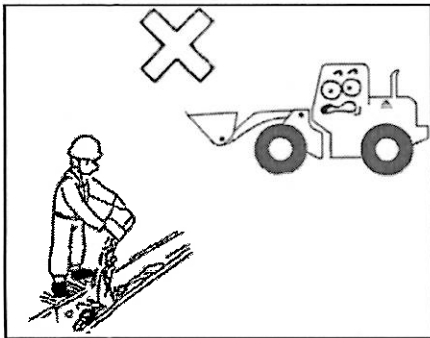

### Overhaul of hydraulic system

#### Attention

- If the following problems are discovered, it shall be replaced:
- Connector is damaged or leaked;
- Exterior layer of flexible pipe is worn out or cracked or reinforced steel wire is exposed.
- Local eminence of flexible pipe
- Flexible pipe has obvious twisting or flattening.
- Reinforced steel wire of flexible pipe is embedded into exterior layer.
- End connector is dislocated.

1. Oil cylinder and other hydraulic devices will be safely locked when overhauling the hydraulic system and hydraulic oil will be cooled, pressure of pressure pipeline, vessel, part and every system will be carefully released to prevent danger when maintaining. Such pipeline, part and system with pressure shall be dismantled by professional personnel through training.



2. High pressure pipeline cannot be bent or hammered. Hard pipe or flexible pipe that has been abnormally bent or damaged cannot be installed on the machine.
3. Any loose or damaged fuel oil and lubricating oil pipeline, hard pipe and flexible pipe of the hydraulic system will be timely repaired. Leakage may cause fire disaster, so, they will be timely repaired or replaced.
4. To prevent oil leakage and eruption of high pressure liquid from injuring personnel, pressing type rubber pipe (or flexible pipe) cannot be repaired and used again after damaging. New component will be replaced.
5. Pipeline (hard pipe and flexible pipe) will be carefully checked. All connectors will be tightened as per stipulated torque. Leakage cannot be checked by bare hands, which need be checked by using plate or paperboard. Even if pinhole liquid leakage may penetrate into muscle and even cause casualty. If solution is sprayed to skin, it shall be handled by surgeon who is familiar with this injury within several hours.
6. Installation of all pipe clamps, guard plates and heat resistant covers is correct to avoid vibration or overheating due to friction with other components.
7. Suitable vessel shall be selected to accommodate liquid when replacing oil of hydraulic system and components such as filter. Disposal of waste liquid is shown in "P69 disposal of dangerous materials and waste materials".

### **Safely conduct maintenance of air conditioning system**

1. If refrigerant splashed to skin, it may generate local cold injury.
2. When maintaining air conditioning system, you will refer to correct utilization method of Freon vessel.
3. Recycling and recirculating system will be used to prevent Freon emission from entering air.
4. Freon vapor cannot contact skin.
5. When dismantling connecting pipe of air condition compressor, open fire is prohibited. Otherwise, it will generate toxic gas to cause poisoning accident. At this moment, mask will be worn.

### Air storage tank

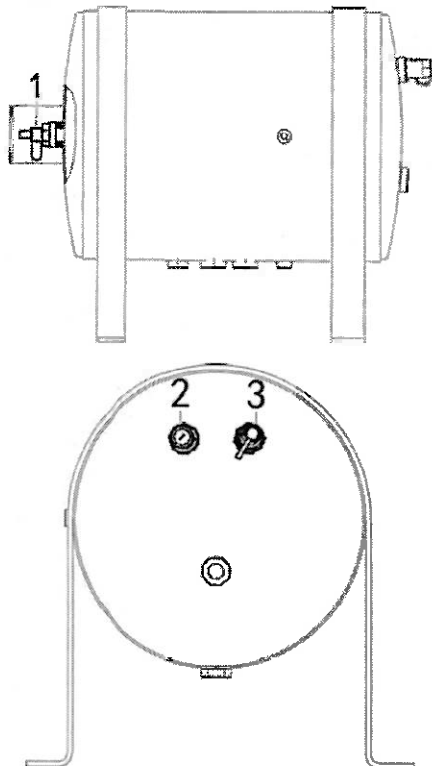

- 1 Water drain valve
- 2 Safety valve
- 3 Tyre inflation valve

- Operation methods to discharge water from air storage tank: the machine will be parked on flat ground, the parking brake switch will be pressed or the parking brake lever will be pulled up, brake pedal will be stamped and loosened continuously, pressure in the air storage tank will be released and then the water drain valve in the bottom of the air storage tank will be opened for discharging water.

**Attention: water will be discharged from air storage tank every day. In particular, complete water discharge will be conducted for at least once in every day in the winter. The water drain valve must have been closed before starting the machine.**

- Air storage tank will be maintained strictly in accordance with identification on the air storage tank.
- As the air storage tank has high pressure gas, external check shall be usually conducted for air storage tank, and erosion resistant coating and weld joint will be checked to guarantee utilization safety.
- When the pressure of air storage tank is too large, the air storage tank can automatically discharge pressure via the safety valve on the tank.

### Electrical system

- Repair and maintenance work of electrical system shall be conducted by personnel with professional qualification.
- When regulating external power supply, the grounding cable will be connected at last to prevent spark generated surrounding the battery from explosion.
- Key of starting switch must be taken out before repairing electric system.

### Avoid fire disaster

1. Fire extinguishing system will be checked to guarantee it is under good condition all the time. You need know positions and utilization methods of fire extinguisher and first aid kit. Once fire disaster occurs, it is helpful for operators to adopt remedy measures.
2. The engine must be closed when injecting fuel oil or fuel system is opened to contact surrounding air. Smoke and open fire are prohibited in the process of oil filling.
3. Fuel oil, lubricating oil or other flammable substances will be stored in place with low temperature and good ventilation. They cannot be used together with suction air electric pre-heating device. What's more, open fire



is prohibited.

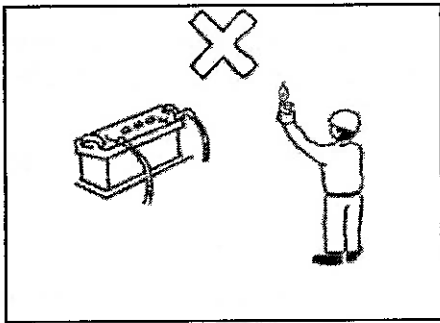

4. Condenser will be regularly cleaned by using compressed air or cold water. It is strictly prohibited to use hot water to clean the condenser.
5. The site of working, repair and maintenance site will be kept clean. The ground will become slippery due to oil and water. What's more, oil and water are also dangerous to electric equipment and electrical tools. Clothes containing engine oil and grease are potential hazard of fire disaster.
6. The loader and equipment will be daily checked to guarantee there is not oil and ash on the lower plate of the vehicle body; flammable materials such as fuel oil, lubricating oil or other fragment and flammable substances stacked on the machine have been cleared. On in this way, can fire disaster danger be reduced and can easily figure out fault or loose components.
7. Explosive gas will be generated surrounding the storage battery. Smoke cannot be close to it. The storage battery will be repaired, maintained and used strictly in accordance with product specification.
8. When parking the vehicle, attentions will be paid to the environment surrounding the vehicle. In particular, flammable substances such as withered grass and old paper are prohibited near the high temperature parts such as silencer.
9. Fuel pipeline, hydraulic and braking flexible pipes will be checked to confirm whether they have been worn out or whether there is damage risk due to incorrect installation or being squeezed.
10. Electric wire will be checked to confirm whether there is leakage or not. If it is damaged, it need be repaired or replaced. Any damaged wire need be repaired or replaced, which is vital significant for non-fuse circuit. Its color is red and marked with R(B+). The line is:
  - a) Among storage batteries
  - b) Between storage battery and starting engine
  - c) Between AC generator and starting motor



**Attention: cable cannot be directly leaned against oil pipe or placed on fuel pipe.**

11. Component shall be cleaned by using non-flammable solvent, which cannot be cleaned by using gasoline or other flammable liquid. Component will be cleaned by using recognized solvent. You need remember that some solvent will cause rash and constitute potential hazard of fire disaster. Therefore, special attention is

required when using.

12. Electric welding or flame cutting cannot be conducted for pipelines or tanks containing flammable liquid. Before electric welding or cutting, they shall be cleaned by using non-flammable liquid. Welding operation will be conducted carefully in places near these areas. Fire extinguisher shall be at hand all the time.
13. Open fire cannot be used (matchstick, lighter, and so on) when checking dark place.
14. Measures once fire disaster occurs:
  - a) If situation permits, and your safety can be guaranteed, the following steps will be adopted when the smallest sign of fire disaster occurs:
  - b) The machine shall be stopped if the machine is being operated.
  - c) Accessory device is descended to the ground.
  - d) Control locking rod will be moved to locking position, if it has been installed.
  - e) Ignition key is adjusted to the position of "STOP".
  - f) Leave the cab.
  - g) Call fire brigade.
  - h) Try to put out the fire if possible. If the fire cannot be put out, you need keep away from the machine and dangerous area.
15. Measures after fire disaster:
  - a) When disposing machinery equipment suffering from fire disaster or superheat damage, the protective measures must be adopted under any circumstance:
  - b) Thick rubber protective gloves and safety glasses will be worn.
  - c) Hand cannot directly contact parts to prevent contacting melted polymeric materials. Lots of whitewash will be used (a solvent containing calcium hydroxide namely hydrated lime dissolved in water) to completely flush.
  - d) As preventive measures, way for disposing seal ring (O-shaped seal ring and other oil seal) is the same to that for disposing fluororubber products.
  - e) As for skin that may have previously contacted fluororubber, hydrofluoric acid burn cream will be coated and doctor's opinions are required. As symptom will occur after several hours.

- f) Gloves and duster cloth that may have contacted burning fluororubber must be scraped.



**Attention:** heated fluoro-carbon rubber will be disposed in accordance with the P70.

### **Provisions on filling fuel oil or lubricating oil**

Fuel oil, lubricating oil, hydraulic oil and antifreeze can be ignited by open fire. Therefore, the following provisions must be abided by:

1. The engine will be closed when filling fuel oil or lubricating oil.
2. No smoking
3. Overflowed fuel oil, lubricating oil, hydraulic oil and antifreeze will be immediately cleared.
4. The top covers of vessels of fuel oil, lubricating oil, hydraulic oil and antifreeze will be tightened.
5. Places for filling or storing fuel oil, lubricating oil, hydraulic oil and antifreeze will have adequate ventilation.

### **Maintenance of storage battery**

Electrolyte of the storage battery contains sulfuric acid and can generate hydrogen and oxygen when the storage battery is being charged. Therefore, wrong disposal of the storage battery will cause serious injury or fire disaster. Thus, the following instructions must be abided by:

1. As the storage is strongly corrosive due to sulfuric acid, children need keep away from it. Users shall wear protective glasses and rubber gloves when operating the battery. Once eyes, skin and clothes contact sulfuric acid, they will be immediately flushed with lots of clean water. If the situation is serious, they need to get medical treatment.
2. If any personnel drinks electrolyte, it shall drink lots of water or milk or eat raw eggs or vegetable oil and immediately seek for help of doctors or emergency center.
3. The engine will be closed before conducting work related to the storage battery.
4. The storage battery will generate hydrogen and oxygen when being charged. Explosion will occur once open fire is close or exhaust port is blocked. Therefore, the storage battery shall be far away from open fire and short circuit due to careless contact of metal object (such as tool) will be avoided.



5. When cleaning the top surface of the storage battery, it will be scrubbed with cloth. Gasoline, solvent, any organic solvent or cleaning agent cannot be used. Battery housing is flammable substance, which shall be far away from open fire.
6. The battery cannot be reversed and lay down and cannot receive any mechanical impact and great pressure.
7. The storage battery shall be stored in dry, clean and ventilated environment under the temperature of 5-25°C. Direct sunshine shall be avoided. It shall be at least 2m away from heat source. If the environmental temperature is too high, it will cause great influence to performance of the battery. It can be stored for six months under room temperature. Battery can be used without charging within six months. If the storage period is over six months, the battery can be used after charging. If battery installed on vehicle is not used for long time (in general, it means to over fifteen days), it will be dismantled from the vehicle and stored in ventilated and dry place and will be charged for once every three to six months (determined based on whether the indicator blackens or not).
8. Before installing the battery, attentions will be paid to safety sign on the battery label to prevent occurrence of unnecessary accident. In addition, a little Vaseline shall be coated on end post to prevent corrosion. Wiring shall be solid and reliable. It is strictly prohibited to knock on end post to prevent end post from loosening so that battery leaks acid.
9. When installing, the positive pole of the storage battery shall be connected to the positive pole of the vehicle engine at first and negative pole of the storage battery will be connected to the negative pole of the engine. When dismantling the storage battery, the negative pole will be disconnected (on one side of the ground wire). If electrolyte of the storage battery is close to "lower liquid level", distilled water will be filled. Distilled water cannot exceed "upper liquid level".
10. The battery will be solidly placed on the battery rack by means of upper fixation or lower fixation to avoid battery damage due to loosening. The top cover of the storage battery will be tightened.
11. The battery cover is equipped with indicator displaying electrical charge state of the battery. When the indicator is green, the battery can be normally used. When the indicator is black, the battery shall be timely charged. When the indicator is white, the battery shall be immediately replaced.



Power-lack battery due to various reasons in the utilization process shall be timely charged to prevent performance reduction due to sulfation of the battery.

### **Charging of the storage battery**

If the storage battery has not been disposed correctly when charging the storage battery, the storage battery may be exploded. Therefore, it shall be executed in accordance with disposal regulation of the storage battery and provisions related to charging in the specification and the following instructions shall be abided by:

1. Constant voltage charging method is recommended for the storage battery:
  - a) Supplementary charging of the battery: the battery will be charged for 16 hours via 16.0V (maximum current is not more than 25A).
  - b) Normal charging of the battery: the battery will be charged for 24 hours via 16.0V (maximum current is not more than 25A).
2. The storage battery will be removed from the machine before charging. Charging will be conducted in ventilated place. The top cover will be removed from the storage battery, which can diffuse hydrogen and prevent explosion.
3. When the battery is being charged, positive pole of the battery charger shall be connected to the positive pole of the storage battery and the negative pole of the battery charger will be connected to the negative pole of the storage battery. Reverse charging is strictly prohibited.
4. The battery will generate gas when charging. Therefore, the battery shall be regularly checked to confirm the exhaust port is not blocked to prevent battery from explosion.
5. In the charging process, when the electrolyte temperature of the battery is over 45°C, the charging voltage or charging current shall be reduced based on actual situation to prevent electrolyte from splashing due to high temperature.
6. Excessive charging is strictly prohibited in the utilization process and in the charging process of the battery to prevent battery from too early invalidity due to excessive water loss, production of grid and falling of diachylon.

7. If the charging rate of the storage battery is lower than I/O, high-speed charging will be conducted and the value will be set below the rated capacity of the storage battery. If the charging current is too large, it may cause electrolyte leakage or evaporation, which may cause ignition or explosion.
8. If the electrolyte of the storage battery has been frozen, the storage battery cannot be charged and the engine cannot be started by using other power supply, which is dangerous and will ignite the storage battery. When charging or using other power supply to start the engine, electrolyte of the storage battery will be melted before starting and check will be conducted to confirm whether there is leakage or not.

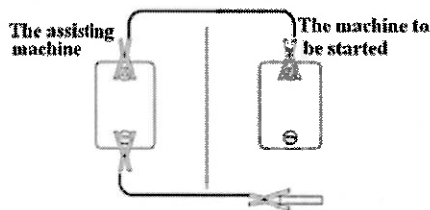

### **Start with booster cable**

If connection method of booster cable has any error, it may cause fire disaster. Therefore, it shall be conducted as per the following methods.

1. Two operators are required for conducting starting operation (one operator sits on the seat of operator).
2. When starting another machine, two machines cannot contact.
3. When connecting booster cable, the starting switches of normal machine and machine with fault will be closed.
4. When installing booster cable, positive (+) cable must be connected at first. When dismantling booster cable, ground wire or negative pole (-) cable will be disconnected at first.
5. At last, the ground wire will be reliably connected to car frame of machine with fault. Connection will be conducted in place that is far away from the battery.
6. When dismantling booster cable, clamp of the booster cable cannot contact each other or clamp cannot contact the machine.

## Disposal of dangerous materials and waste material

### 1. Heated oil paint

 **Warning:** all oil paint will be decomposed when heating, which may generate thrill compound. These substances will cause allergy. It is very harmful for health if any personnel is exposed in it for long time or frequently exposed in it.

Heated oil paint will release toxic gas. Therefore, oil paint must be cleared from an area whose radius is at least 10cm (4 in) before welding, polishing or gas cutting. Except for health hazard, quality and strength of weld joint will be very poor, which will cause weld breakage in the future. Therefore, welding operation cannot be directly conducted on oil paint surface.

Technology and instructions when removing paint surface:

- a) Strong air (use respirator and safety glasses);
- b) Oil paint remover or other chemicals (use portable air pump, respirator and safety glasses);
- c) Polishing machine (after using portable air pump, respirator, protective gloves and safety glasses, parts coated with oil paint cannot be burned. They shall be disposed by a factory with license);

2. Heated rubber and plastics

Polymeric materials may form compound that is harmful for health and environment when heating. Therefore, it cannot be burned when scraping.

If gas cutting or welding is conducted near these materials, the following safety instructions must be abided by:

- a) Prevent these materials from being heated.
- b) Protective gloves, safety glasses and respirator will be used.

3. Heated fluororubber



**Warning: design of some sealants can bear high working temperature such as sealant on engine, master control valve and pump as they may be made of fluorocarbon compound. When it is heated to high temperature, fluorocarbon compound rubber will be decomposed into hydrogen fluoride and hydrofluoric acid. They are strongly corrosive to skin and respiratory tract.**

The following measures shall be adopted when disposing machine that has been burned or has been previously exposed in high heat:

- a) Thick rubber glove and safety glasses will be used.
- b) Gloves, cloth and other objects that have contacted heated fluorocarbon rubber will be discarded, which will be cleaned with whitewash (a solvent of calcium hydroxide namely soluble hydrated lime) at first.
- c) Hydrated lime shall be used to adequately and completely eliminate pollution surrounding parts that were very hot and may be made of fluorine-carbon.
- d) As a preventive measure, all seal parts (O-shaped ring or other oil seal) shall be disposed as fluorine-carbon rubber
- e) After fire disaster, hydrofluoric acid may stay on the machine for several years.
- f) If edema, swollen or pricking that may be caused due to contacting heated fluorine-carbon rubber occurs, you will immediately contact doctors. Symptom will occur several hours later and there is not any real-time alarm.
- g) Acid cannot be flushed from skin, which shall be disposed by using hydrofluoric acid gel or similar product. In addition, you will contact doctors.



#### 4. Refrigerant



**Attention:** maintenance conducted on air conditioning unit must be undertaken by personnel with experience and corresponding qualification certificates in the qualified repair plant.



**Warning:** if refrigerant 134a contacts exposed skin, it is very easy to generate cold injury. It will form gas after heating, which will harm lung and nervous system.

Air conditioning unit of the machine has been filled with refrigerant R134a in the factory. R134a does not have adverse influence on ozone layer, but it will increase greenhouse effect. Therefore, it cannot be released to air on purpose.



**Important:** R134a cannot be mixed with other types of refrigerants such as R12, which may cause unit fault.

If contacting escaped refrigerant, the following measures shall be adopted:

- a) If any leakage, you need leave the dangerous area and contact a qualified repair plant to understand measures that shall be adopted.
- b) Gas generated by heated refrigerant may harm lung and nervous system even if the concentration is very low and no odor cannot be smelt. High concentration will have anesthesia effect. Personnel exposed in it shall be moved out of dangerous area and enter into fresh air. If symptom continues, you need ask for medical treatment.
- c) Liquid refrigerant may cause cold injury. Warm water or warm clothes will be used to warm injured area. If symptom continues, you need ask for medical treatment.
- d) If liquid refrigerant enters into eyes, you need ask for medical opinions.

#### 5. Silicon crystal (quartz) dust



**Warning:** don't expose in dust containing silicon crystal particle. As it will cause serious injury to lung (silicosis).

Silicon crystal is basic composition of sand and granite. Therefore, many activities conducted on buildings and mining field such as excavation, saw cutting and drilling will generate silicon crystal dust. This dust may cause silicosis.



The employer and manager of the working site shall provide information about existence of silicon crystal in the working place and special working instructions and preventive measures as well as necessary personal protective equipment for operators. What's more, they shall check local and national provisions on silicon dioxide and silicosis.

6. Waste that is harmful for the environment
  - a) Oil discharged by the machine will be placed in the vessel. Oil cannot be directly discharged to the ground or poured into underground pipeline and rivers.
  - b) When disposing hazardous substances such as lubricating oil, fuel oil, cooling solution, solvent, filter, storage battery and other substances, relevant laws and regulations will be abided by.
  - c) Components to be scraped and that have been painted or components made of plastic or rubber cannot be burned, which must be disposed by recycling treatment plant with approval.

## Hood

Non-gold-plating metal hood cannot be repaired on your own. Dust generated due to polishing non-metallic hood may explode: in addition, dust absorption will be harmful for your health.

## Regular replacement of wear-out part and key safety components

Wear-out part and key safety components shall be regularly replaced.

### 1. Details of quick-wear parts

No.	Name	Quantity	Remark
1	Tyre	4	
2	Bucket	1	
3	Brake	6	

### 2. Details of safety parts:

No.	Name	Quantity	Remark
1	Locking rod	1	
2	Mounting plate	1	Optional
3	Triangle shim	2	

## Safe transportation

### Loading and unloading machine

1. Loading and unloading of the machine exist potential hazard all the time, and it shall be handled with care. When loading and unloading machine, the engine will be operated at low speed and the machine will be driven at low speed.
2. The machine will be loaded and unloaded on solid flat ground and kept safe distance away from the roadside.
3. The tyre of the transport vehicle will be fixed when loading and unloading the machine to guarantee transport vehicle will not be moved and cushion block will be placed below the spring board.
4. Cantboard with enough strength will be used. The cantboard will have enough width and length to provide a safe inclined slope for loading and unloading. The angle between the cantboard and the ground cannot be more than 15°. Distance among cantboards will be adapted to the wheelspan of the machine.
5. The cantboard will be located solidly and heights on two sides are the same.
6. The surface of cantboard is clean without oil stain, lubricant, ice and scattered material. Dirt on the tyre of the machine will be cleared.
7. Steering cannot be conducted on the cantboard. If necessary, the machine shall be driven away from the cantboard and drive on it after the direction is adjusted.
8. After loading, safety locking rod will be used to tighten the steering mechanism and peg tyre of the machine. The machine will be tightened with rope via the lifting eye for fixation. Lifting eye for fixation is shown in the P 4 and P14.

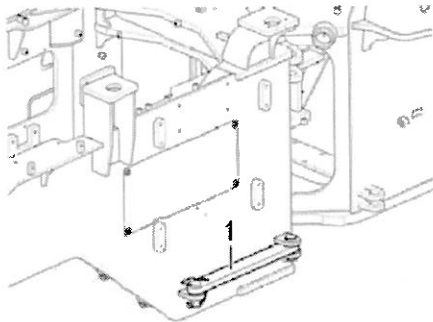

1 Frame locking rod

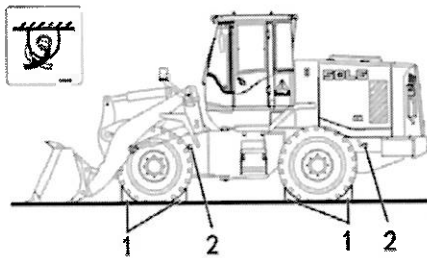

1 Support the wheel

2 Tie the fixation point

### Road transportation



**Attention: to prevent air from being squeezed into air exhaust pipe in the process of transportation, suitable protective articles (non-plastic) shall be used to cover the air exhaust pipe, otherwise, it may damage the turbocharger.**

1. When transporting the loader, the bucket direction will be consistent with the driving direction of transport vehicle.
2. When the machine is transported by using trail, provisions of the local and national laws on weight, height, width and length will be abided by. In addition, relevant traffic laws and regulations shall also be

abided by.

3. Weight, height, width and length of the machine will be considered when determining transportation route.
4. When crossing the bridge or structures in private area, the strength will be checked at first to confirm whether it can support weight of the machine or not. When driving on public roads, it need comply with relevant provisions and abide by these provisions.
5. When considering other ways to transport, the machine may be dismantled. You need contact Shandong Lingong Construction Machinery Co., Ltd. or distributor designated by it.

### Lifting

When the loader need be moved to the transport equipment, it will be lifted by using lifting points on the front and rear frames. More information of lifting point is shown in the P3 and P13.

Suitable lifting machine will be selected as per weight of the machine. It is very dangerous if exceeding load limit of the lifting machine. Special attention shall be required.

Instructions for lifting:

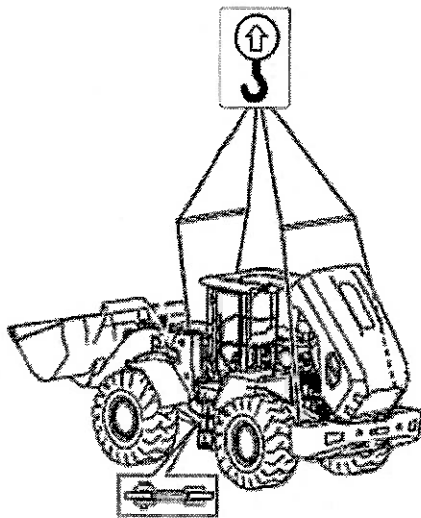

1. Before lifting, the loader is under transportation state, front and rear frames must be centered. In addition, frame locking rod must have solidly locked the front and rear frames to avoid mutual rotation of front and rear frames when lifting. More information about frame locking rod is shown in the P14.
2. All control handles shall be at the neutral position.
3. The engine will be closed, and key will be used to lock all equipment and then will be removed.
4. No one is in the cab.
5. It is prohibited to use a section of steel wire rope to connect two hooks of front frame.
6. Four pieces of steel wire ropes with the same length (not less than 7m) can be used for lifting.
7. The machine can be under horizontal state after being lifted.
8. Attention will be paid to avoiding hood, cab and hydraulic pipe from being damaged.
9. When lifting, any personnel or vehicle cannot stand below the lifted loader.
10. After lifting is completed, the frame locking rod must be collected before rotating the loader.

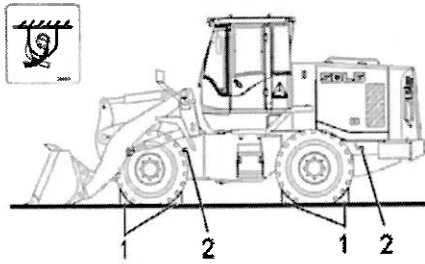

1. Support the wheel
2. Tie to the fixation point

### Tie the machine

1. After loading, frame locking rod will be used to tighten and connect steering mechanism.
2. Support the wheel (1)
3. Special fixation point (2) will be used to tie the machine to prevent machine from roll over or reversion.

### Avoid environmental damage

Attention shall be paid to environmental protection during the period of maintenance and repair. If oil liquid that is harmful for the environment is discharged to the environment, it will pollute the environment. Degradation of oil in water and sediment is very slow. One liter of oil is enough to pollute millions of liters of drinking water.



#### Attention

**As for the following points, all wastes must be sent to officially recognized waste management company for disposal.**

1. When discharging, oil liquid must be collected in suitable vessel and measures will be adopted for preventing overspill.
2. Before disposing used filter, all working solution must be discharged. If the machine works in environment containing asbestos or other dust that is harmful for health, used filter of the machine will be placed in the seal bag of new filter.
3. As the storage battery contains substance that is harmful for personal health and environment, used storage battery must be disposed as waste that is harmful for the environment.
4. Used consumables including duster cloth, gloves and bottle may also be polluted by oil liquid that is harmful for the environment. Therefore, they must be disposed as waste that is harmful for the environment.

# Product introduction

## Appearance and name of all parts

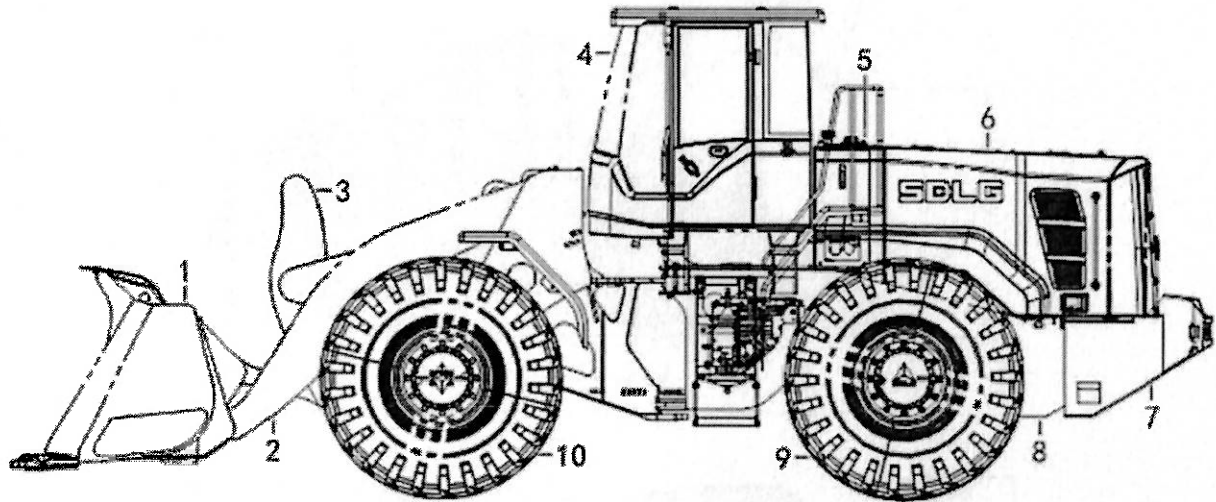

1.Bucket 2.Boom 3.Rocker arm 4.Cab 5.Hydraulic oil tank 6.Engine hood 7.Balance weight 8.Rear frame

9. Rear wheel 10. Front wheel

Appearance and name of all parts

### Outline dimensional drawing

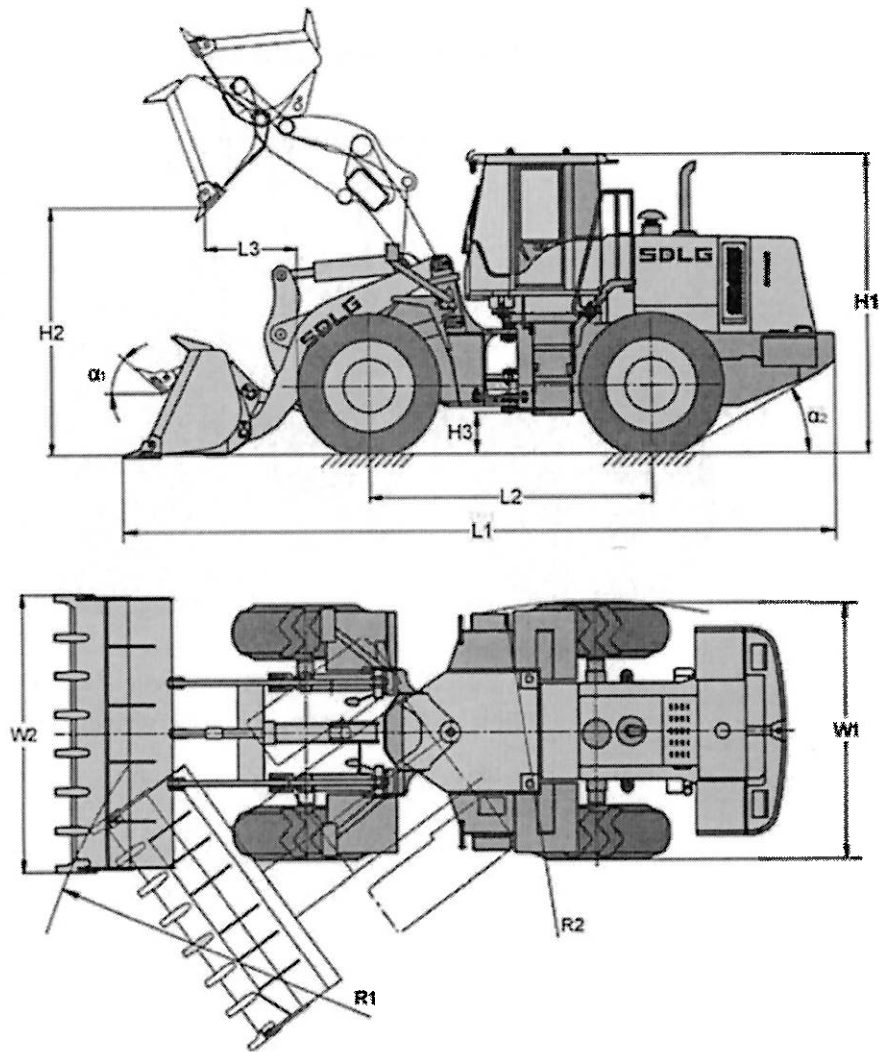

Outline dimensional drawing of the complete machine





## Operation & Maintenance Manual for L968F Wheel Loader

### Domestic

Parameter Item (unit mm)	Standard boom	Heightened boom	Superhigh boom
Vehicle length L1	8680	9120	9420
Vehicle width (outside of the wheel) W1	2925	2925	2925
Vehicle height H1	3520	3510	3510
Maximum unloading height H2 (-45° unloading angle)	3270	3630	3875
Corresponding unloading distance L3 (-45° unloading angle)	1070	1190	1276
Wheel base L2	3400	3400	3400
Bucket width W2	3038	3038	3038
Minimum ground clearance H3	530	530	530
Horizontal clearance radius R1 (outside of bucket)	7057	7260	7406
Minimum turning radius R2 (outside of rear wheel)	6062	6062	6062



## Operation & Maintenance Manual for L968F Wheel Loader

Domestic (Tyre of 23.5-25)

<b>Item (unit mm)</b> \ <b>Parameter</b>	<b>Standard boom</b>	<b>Heightened boom</b>	<b>Superhigh boom</b>
Vehicle length L1	8680	9120	9420
Vehicle width (outside of the wheel) W1	2845	2845	2845
Vehicle height H1	3410	3410	3410
Maximum unloading height H2 (-45° unloading angle)	3200	3580	3805
Corresponding unloading distance L3 (-45° unloading angle)	1140	1250	1345
Wheel base L2	3400	3400	3400
Bucket width W2	3038	3038	3038
Minimum ground clearance H3	470	470	470
Horizontal clearance radius R1 (outside of bucket)	7057	7260	7406
Minimum turning radius R2 (outside of rear wheel)	6062	6062	6062



## Operation & Maintenance Manual for L968F Wheel Loader

Exported

<b>Parameter Item (unit mm)</b>	<b>Standard boom</b>	<b>Heightened boom</b>	<b>Superhigh boom</b>
Vehicle length L1	8680	—	—
Vehicle width (outside of the wheel) W1	2845	—	—
Vehicle height H1	3520	—	—
Maximum unloading height H2 (-45° unloading angle)	3200	—	—
Corresponding unloading distance L3 (-45° unloading angle)	1140	—	—
Wheel base L2	3400	—	—
Bucket width W2	3038	—	—
Minimum ground clearance H3	470	—	—
Horizontal clearance radius R1 (outside of bucket)	7057	—	—
Minimum turning radius R2 (outside of rear wheel)	6062	—	—

## Constituent and meaning of product model

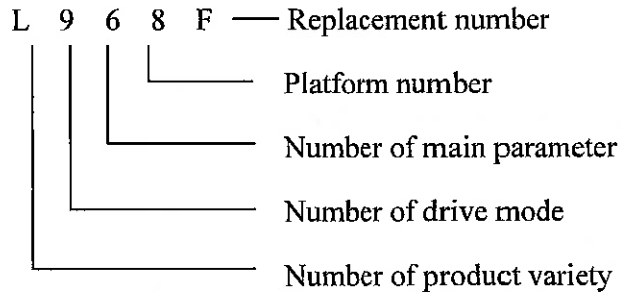

## Scutcheon

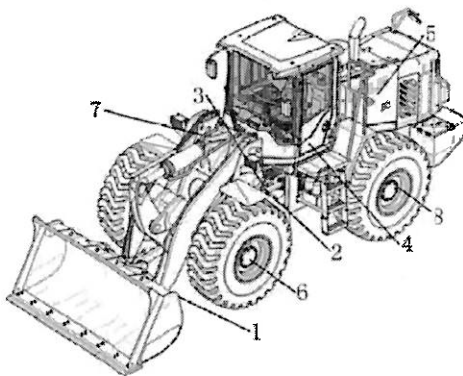

The left figure has shown positions of all scutcheons on the machine, the following comes with description. When purchasing spare parts and conducting telephone consulting or contacting, model of the machine and product identification number must be provided.

### 1. Bucket scutcheon

This scutcheon is installed in the top of the bucket to show serial number of bucket, part number and rated capacity.

### 2. Main sign

Product identification number (PIN) of the machine is printed on the left side of the rear end of the front frame.

### 3. Product scutcheon

This scutcheon of the machine is on the left side of the rear end of the front frame showing vehicle type, product identification number, manufacturing date and manufacturer. The scutcheon type is shown in the left figure.

	<input type="text"/>	<b>WHEEL LOADER</b>	
Rated Load	<input type="text"/> kg	Operating Mass	<input type="text"/> kg
Engine Model	<input type="text"/>	Engine Power	<input type="text"/> kW
Dimension	<input type="text"/> mm	Manufacturing Year	<input type="text"/>
Product Identification Number <input type="text"/>			
<small>SHANDONG LINGONG CONSTRUCTION MACHINERY CO.,LTD. LINGONG INDUSTRY PARK, ECONOMIC &amp; TECHNOLOGY DEVELOPMENT ZONE, JIANGSU PROVINCE</small>			



## Operation & Maintenance Manual for L968F Wheel Loader

---

### 4. Cab

This scutcheon has shown material number, supplier number and delivery number of the cab.

### 5. Engine scutcheon

The scutcheon has shown model name of the engine and part number.

### 6. Front axle

Component number, type and production serial number of front drive axle

### 7. Transmission

Name and address of the manufacturer and part number of the transmission

### 8. Rear axle

Component number, type and production serial number of rear drive axle.

## Function

### Warning

The following operations are prohibited for the loader:

1. Use under overload
2. Use under unbalance loading
3. Excavate hard material
4. Rope is directly hanged to bucket teeth for lifting heavy object.
5. Excavation is conducted above the machine by lifting the bucket.

The machine is tyred loader with single bucket, front discharging and hinge joint. It has been widely applied in operation on mine field, infrastructure, road construction, enterprise, goods yard and port. It is a kind of construction machinery with multiple functions and high efficiency. The machine is mainly engaged in the following operations:

- Loading operation
- Shoveling operation
- Transportation operation
- Unloading operation

Details are shown in the P131 operation.

### Requirement for working environment

The loader is applicable to the following environment:

1. Altitude:  $\leq 2000\text{m}$ ;
2. Ambient temperature:  $-15^{\circ}\text{C}$ - $+40^{\circ}\text{C}$  ;
3. Fording depth:  $\leq 500\text{mm}$ .

The loader is common construction machinery, which is used in various applications mentioned in the manual under normal conditions. If it is used for other purposes or in environment with potential hazard, such as flammable and explosive air or area containing asbestos dust. At this moment, special safety provisions must be abided by. What's more, this machine must be equipped with corresponding device with corresponding functions.

**Attention: please contact our company in advance if it need be used beyond this environmental condition, otherwise, incurred consequence will not be undertaken by the company.**

## Characteristics



## Operation & Maintenance Manual for L968F Wheel Loader

---

1. It is equipped with electric control engine meeting Phase III emission standard with low speed and big torque, strong impetus and high reliability; it has fault test interface, which can conveniently achieve test and maintenance of the engine. (Domestic-oriented)
2. It is equipped with engine meeting national Phase II emission standard with low speed and big torque, strong impetus and high reliability. (Export-oriented)
3. Employ SDLG self-made VRT200 fixed shaft electro-hydraulic shift transmission, four forward and four reverse, with high transmission efficiency and stable operation. Employ enhanced drive axle which has strong carrying capacity and prolongs life-span of 50%.
4. The wheelbase is 3400, which promotes the stability of the overall and the tipping load is increased; the front and rear axle employs 20 ply rating 26.5-25 oversized tire with strong carrying capacity and is fit for heavy load conditions.
5. A new generation of optimized front and rear frame with reasonable load distribution that can reduce vibration and promote twice of the fatigue life.
6. Employ new streamlined appearance design and the overall has attractive appearance; the space of the new generation cab is enlarged 15%, safe and comfortable.



**Technical performances and parameters**

L968F (Domestic)

		Equipped with standard boom	Equipped with heightened boom	Equipped with superhigh boom	
Bucket capacity (m <sup>3</sup> )		3.5	3.5	3.5	
Rated load(kg)		6000	6000	5500	
Lifting time of bucket(full load) (s)		≤5.8	≤5.8	≤5.8	
Fall time of bucket (no-load) (s)		≤4.2	≤4.2	≤4.2	
Discharging time of bucket (no-load) (s)		≤1.2	≤1.2	≤1.2	
Speed (km/h)	Forward	Gear I	0~7	0~7	0~7
		Gear II	0~13	0~13	0~13
		Gear III	0~28	0~28	0~28
		Gear IV	0~38	0~38	0~38
	Backward	Gear I	0~7	0~7	0~7
		Gear II	0~13	0~13	0~13
		Gear III	0~28	0~28	0~28
		Gear IV	0~38	0~38	0~38
Max. breakout force (kN)		≥210	≥180	≥180	
Max. tractive force (provided by the engine) (kN)		180	180	180	
Tipping load (kN)		≥128	≥120	≥110	
Max. climbing gradient ( °)		—	—	—	
Max. turning angle ( °)		38	38	38	
Inflation pressure of tyre (MPa)	Front wheel	0.40±0.01	0.40±0.01	0.40±0.01	
	Rear wheel	0.35±0.01	0.35±0.01	0.35±0.01	
Specification of tyre		26.5-25	26.5-25	26.5-25	
Working mass of the complete machine (kg)		19800	20400	20900	
Rated power of the engine (kW)		178	178	178	





## Operation & Maintenance Manual for L968F Wheel Loader

L968F (Tyre 23.5-25)

			Equipped with standard boom	Equipped with heightened boom	Equipped with superhigh boom
Bucket capacity (m <sup>3</sup> )			3.5	3.5	3.5
Rated load(kg)			6000	6000	5000
Lifting time of bucket(full load) (s)			≤5.8	≤5.8	≤5.8
Fall time of bucket (no-load) (s)			≤4.2	≤4.2	≤4.2
Discharging time of bucket (no-load) (s)			≤1.2	≤1.2	≤1.2
Speed (km/h)	Forward	Gear I	0~7	0~7	0~7
		Gear II	0~13	0~13	0~13
		Gear III	0~28	0~28	0~28
		Gear IV	0~38	0~38	0~38
	Backward	Gear I	0~7	0~7	0~7
		Gear II	0~13	0~13	0~13
		Gear III	0~28	0~28	0~28
		Gear IV	0~38	0~38	0~38
Max. breakout force (kN)			≥210	≥180	≥180
Max. tractive force (provided by the engine) (kN)			180	180	180
Tipping load (kN)			≥123	≥115	≥105
Max. climbing gradient ( °)			—	—	—
Max. turning angle ( °)			38	38	38
Inflation pressure of tyre (MPa)	Front wheel		0.39±0.01	0.39±0.01	0.39±0.01
	Rear wheel		0.33±0.01	0.33±0.01	0.33±0.01
Specification of tyre			23.5-25	23.5-25	23.5-25
Working mass of the complete machine (kg)			19700	20040	20800
Rated power of the engine (kW)			178	178	178



## Operation & Maintenance Manual for L968F Wheel Loader

L968F (Exported)

		Equipped with	Equipped with	Equipped with	
Bucket capacity (m <sup>3</sup> )		3.5	—	—	
Rated load(kg)		6000	—	—	
Lifting time of bucket(full load) (s)		≤5.8	—	—	
Fall time of bucket (no-load) (s)		≤4.2	—	—	
Discharging time of bucket (no-load) (s)		≤1.2	—	—	
Speed (km/h)	Forward	Gear I	0~7	—	—
		Gear II	0~13	—	—
		Gear III	0~28	—	—
		Gear IV	0~38	—	—
	Backward	Gear I	0~7	—	—
		Gear II	0~13	—	—
		Gear III	0~28	—	—
		Gear IV	0~38	—	—
Max. breakout force (kN)		≥210	—	—	
Max. tractive force (provided by the engine) (kN)		170	—	—	
Tipping load (kN)		≥123	—	—	
Max. climbing gradient ( °)		—	—	—	
Max. turning angle ( °)		38	—	—	
Inflation pressure of tyre (MPa)	Front	0.39±0.01	—	—	
	Rear wheel	0.33±0.01	—	—	
Specification of tyre		23.5-25	—	—	
Working mass of the complete machine (kg)		19800	—	—	
Rated power of the engine (kW)		178	—	—	

Note: parameters involved in the manual are applicable to basic configuration. About parameters of modified product, please contact the company for the latest information.

### Product standard

Product execution standard: Q/LGJ 001rubber-tyred loader

# Operation and utilization

## Get acquaintance with the machine

### Control mechanism and instrument (Domestic)

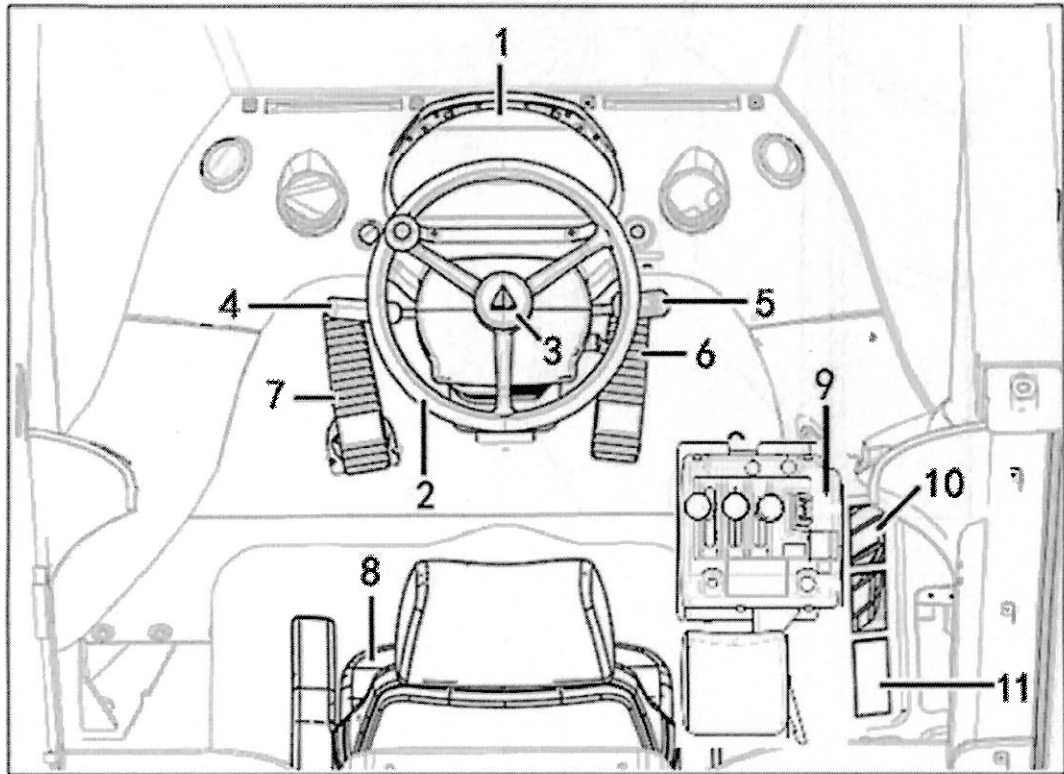

No.	Name
1	Instrument panel
2	Steering wheel
3	Horn button
4	Joy stick of gear
5	Combination switch
6	Accelerator pedal
7	Brake pedal
8	Seat
9	Operation handle of working devices
10	Rocker switch
11	A/C control panel

### Control mechanism and instrument (Exported)

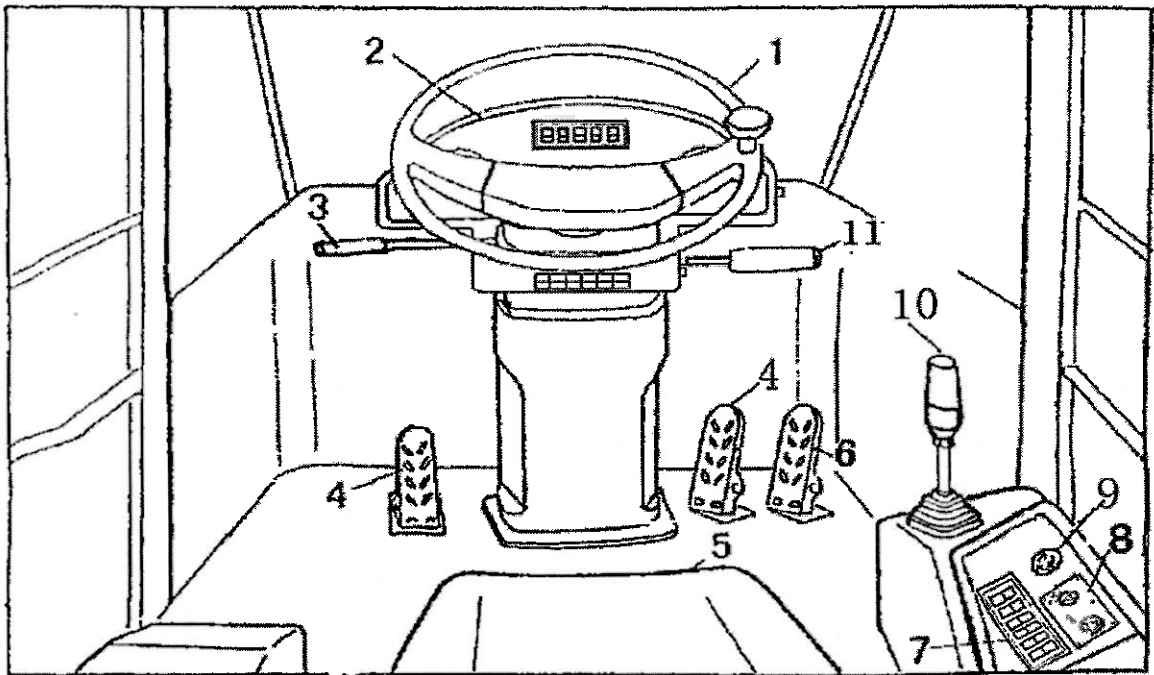

No.	Name
1	Steering wheel
2	Instrument panel
3	Joy stick of gear
4	Brake pedal (each at left and right)
5	Seat
6	Accelerator pedal
7	Rocker switch
8	A/C control panel
9	Parking brake switch
10	Operation handle of working devices
11	Combination switch

### Introduction of instrument and control mechanism

The following is description about instrument and control mechanism that will be used when operating the machine. You must completely understand their operation methods and functions.

Instrument and light of the vehicle (domestic-oriented)

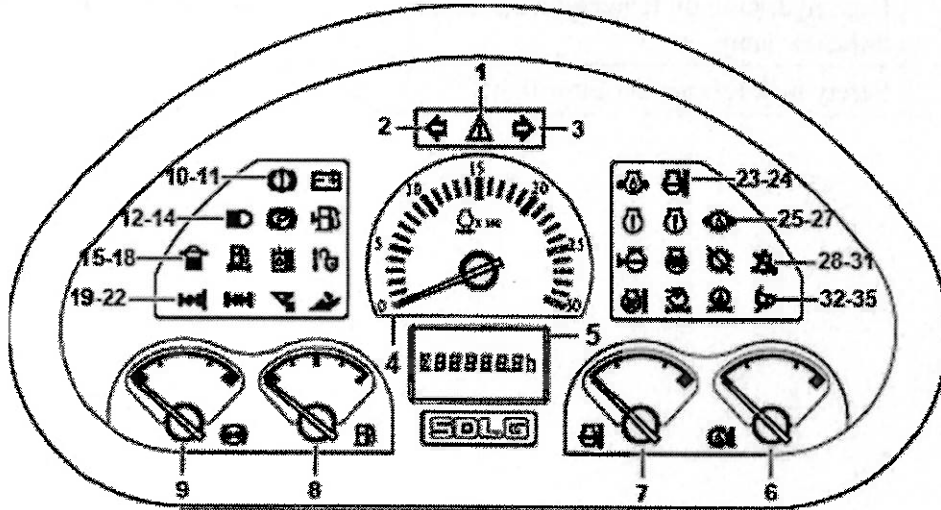

No.	Name	No.	Name
1	Center alarm indicator lamp	19	Bridge heat dissipation indicator light
2	Left steering alarm indicator lamp	20	Differential lock indicator light
3	Right steering alarm indicator lamp	21	Pressure stabilizing system indicator light
4	Engine speed indicator	22	Quick change release indicator light
5	Liquid crystal display	23	Low engine oil pressure alarm indicator lamp
6	Oil temperature gauge of torque converter	24	High coolant temperature alarm indicator lamp
7	Water temperature gauge of engine	25	Engine fault alarm indicator lamp (red)
8	Fuel oil level gauge	26	Engine fault alarm indicator lamp (yellow)
9	Brake pressure gauge	27	Low transmission oil pressure alarm indicator lamp
10	Low brake pressure alarm indicator lamp	28	Low coolant level alarm indicator lamp
11	Charging alarm indicator lamp	29	Preheating indicator light
12	High beam indicator lamp	30	Power shutoff indicator lamp



## Operation & Maintenance Manual for L968F Wheel Loader

13	Parking brake indicator light	31	Mute indicator light
14	Low fuel oil level alarm indicator lamp	32	Independent heat dissipation indicator light
15	Fuel oil moisture alarm indicator lamp	33	Air filter blockage alarm indicator lamp
16	Fuel oil rough filtration alarm indicator lamp	34	Transmission oil rough filtration alarm indicator lamp
17	High hydraulic oil temperature alarm indicator lamp	35	Rear hood opening alarm indicator lamp
18	Safety lock release indicator light	36	

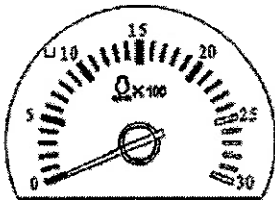
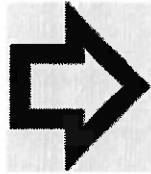

1 Center alarm indicator lamp (red)  
Before starting, engine oil pressure and charging indicator lamps will be lit, this lamp will not alarm. When other faults occur, this lamp will flicker.

2 Left steering alarm indicator lamp (green)  
The symbol will flicker when turning on the alarm lamp or left steering switch.

3 Right steering alarm indicator lamp (green)  
The symbol will flicker when turning on the alarm lamp or right steering switch.

4 Engine speed indicator  
This indicator displays present speed of the engine.

5 Liquid crystal display  
Liquid crystal display will display Shandong Lingong "SDLG" logo in the process of electrification and self-check. Working state is displayed as below:

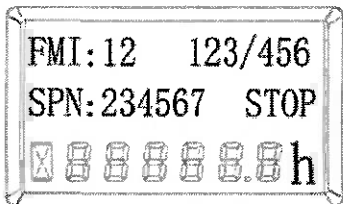
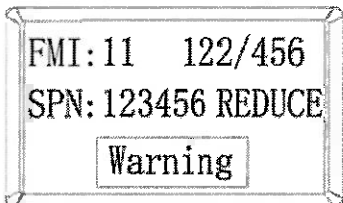
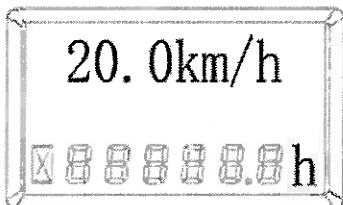

- a) Normal mode:
  - Hourmeter: display format is 00000.0h, maximum display 99999.9h, the icon of funnel shape timing flickers at 2.5S frequency.
- b) Fault mode: liquid crystal display is displayed as per three rows.
  - Row 1 displays FMI:12 (effective digital with one bit or two bits); 1/1 (respectively display present fault /total quantity of faults);
  - Row 2 displays SPN:123456 (effective digital with two to six bits);
  - Row 3 displays: alternately displays WARNING and hourmeter as per 2S replacement frequency (WARNING is reverse display), hourmeter sand clock does not flicker.

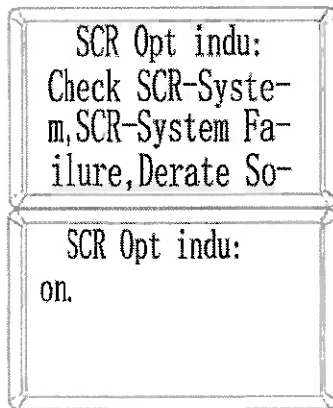

- c) Human-computer interface: liquid crystal display is displayed in four rows
  - Row 1 displays: information title;
  - Rows 2 -4 display: information contents.

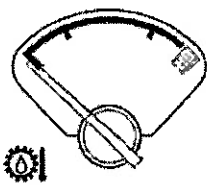

6 Oil temperature gauge of torque converter

When the pointer of oil temperature gauge is within the green range (40°C-120°C), oil temperature is normal. When the pointer reaches red area, the machine shall be stopped for check.

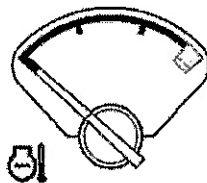

7 Water temperature gauge of engine

This gauge indicates temperature of cooling water of the engine. When the pointer of the water temperature gauge is within the green range(40°C-103°C) , water temperature is normal.



**Attention: if the water temperature of the engine enters into red area, the machine shall be stopped for check.**

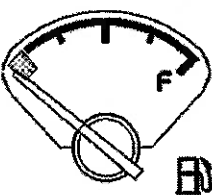

8 Fuel oil level gauge

This gauge shows residual amount of fuel in the fuel tank. When the pointer is within the red area (0~1/8), the machine needs to be filled with fuel timely.

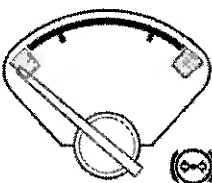

9 Brake pressure gauge

This gauge shows gas pressure in braking system.

When the pointer is within the green range (0.4Mpa~0.9 MPa), the pressure is normal. When it is within other areas, the machine shall be stopped for check.



10 Low brake pressure alarm indicator lamp (red)

When the brake pressure is lower than the alarm point (0.4Mpa) or signal is grounded, it will alarm, this lamp will flicker and the buzzer will send sound.



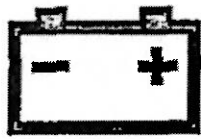

11 Charging alarm indicator lamp (red)

The indicator lamp will be lit after opening the starting switch; after the engine is started, the indicator lamp will go out; otherwise, it means that the storage battery system breaks down, which shall be checked and repaired.



12 High beam indicator lamp (blue)

When the front combination lamp turns on high beam lamp, the symbol will be normally on.



13 Parking brake indicator light (red)

After the instrument is electrified, when the speed of the engine is not more than 1,000n/min and manual braking is not cancelled, this light will be lit;

After the instrument is electrified, when the speed of the engine is more than 1,000n/min and manual braking is not cancelled, this light will be lit and buzzer will alarm, center alarm symbol will flicker;

The parking brake button will be loosened or the parking brake lever will be put down to cancel brake, and this lamp will go out.



14 Low fuel oil level alarm indicator lamp (red)

When fuel oil level is lower than 1/8, this lamp will flicker.

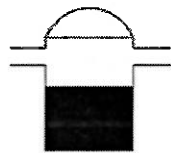

15 Fuel oil moisture alarm indicator lamp (yellow)

When the key is adjusted to ON, moisture in the oil-water separator is too much, and switch is closed, the indicator lamp will be lit. When the lamp is lit, attention will be paid to water discharge of oil-water separator.



16 Fuel oil rough filtration alarm indicator lamp (yellow)

If the lamp is lit, it means rough filter of fuel oil is blocked, which shall be cleared or replaced.

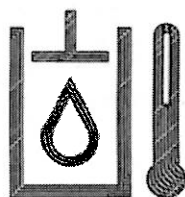

17 High hydraulic oil temperature alarm indicator lamp (red)

When the hydraulic oil temperature is higher than the set value, this lamp will be lit.

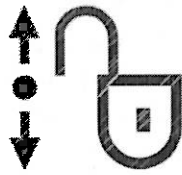

18 Safety lock release indicator light (red)

When the lock switch is connected, and the working device is a free state, this light will be lit, and the buzzer will alarm.



19 Bridge heat dissipation indicator light (yellow)

It is on standby.



20 Differential lock indicator light (yellow)

When the starting switch is adjusted to “ | ” position and the switch is closed, this light will be lit for standby use.



21 Pressure stabilizing system opening indicator light (green)

When device of the pressure stabilizing system is opened, this light will be lit. It is on standby.



22 Quick change indicator light (red)

When the quick change switch is connected, and the accessory device is in a state of quick change, this light will be lit, and the buzzer will alarm. It is on standby.



23 High coolant temperature alarm indicator lamp (red)

When the temperature of coolant of the engine is not less than 103°C, this lamp will be lit, center alarm lamp will be lit and buzzer will send sound.

If such situation occurs, the engine will be immediately closed for investigating reasons.



24 High coolant temperature alarm indicator lamp (red)









When the temperature of coolant of the engine is not less than 103°C, this lamp will be lit, center alarm lamp will be lit and buzzer will send sound.

If such situation occurs, the engine will be immediately closed for investigating reasons.



25 Engine fault alarm indicator lamp (red)

It is on standby.

- |   |  |
|---|--|
|    | <p>26 Engine fault alarm indicator lamp (yellow)</p> <p>When the engine breaks down and signal is grounded, the symbol will be normally on, and buzzer will alarm.</p>   |
|    | <p>27 Low transmission oil pressure alarm indicator lamp (red)</p> <p>After starting, when pressure is low, and switch is closed, signal will be grounded and symbol will flicker, buzzer will alarm; when the switch is disconnected, the symbol will not be lit.</p> |
|    | <p>28 Low coolant level alarm indicator lamp (red)</p> <p>It is on standby.</p>  |
|   | <p>29 Preheating indicator light (yellow)</p> <p>When cold starter is installed, starting switch is adjusted to the preheat position, and this light will be lit; this light at the non-preheat position will go out.</p>  |
|  | <p>30 Power shutoff indicator light (red)</p> <p>When cutting off driving power of the transmission, this light will be lit.</p>   |
|  | <p>31 Mute indicator light (yellow)</p> <p>When parts of faults occur, there will be sound alarm; when mute switch is connected, the sound alarm will stop, indicator light will be lit.</p>   |
|  | <p>32 Independent heat dissipation indicator light (yellow)</p> <p>It is on standby.</p>   |
|  | <p>33 Air filter blockage alarm indicator lamp (yellow)</p> <p>When the engine operates, if this indicator lamp is lit, it means that the air filter is blocked, and needs to be cleaned or replaced.</p>  |
|  | <p>34 Transmission oil rough filtration alarm indicator lamp (yellow)</p> <p>When water content of the transmission oil is higher than the set value on the switch, the switch will be closed, and the alarm symbol will be lit.</p>                                   |



35 Rear hood opening alarm indicator lamp (yellow)

When door of rear hood of the engine is opened, this lamp will be lit. It is on standby.

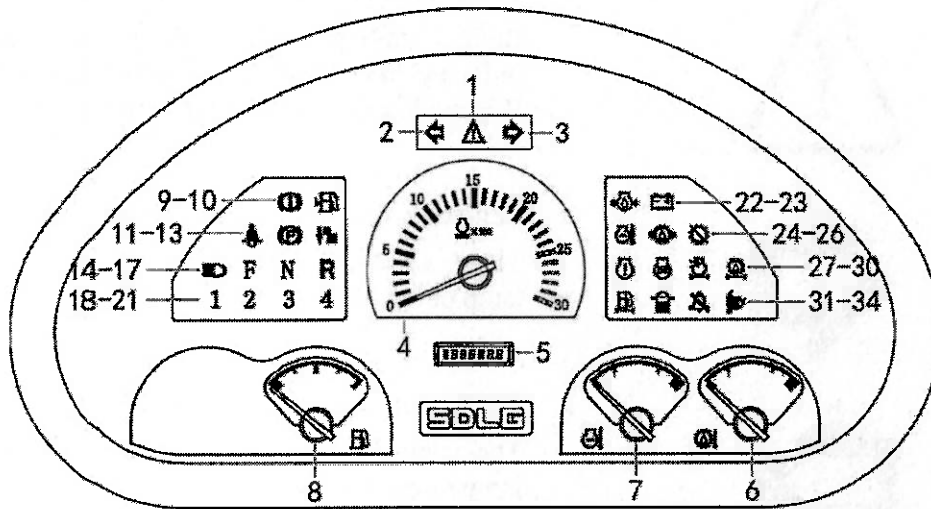

No.	Name	No.	Name
1	Center alarm indicator lamp	18	Gear 1 indicator light
2	Left steering alarm indicator lamp	19	Gear 2 indicator light
3	Right steering alarm indicator lamp	20	Gear 3 indicator light
4	Engine speed indicator	21	Gear 4 indicator light
5	Working hourmeter	22	Low engine oil pressure alarm indicator lamp
6	Oil temperature gauge of torque converter	23	Charging indicator lamp
7	Water temperature gauge of engine	24	High coolant temperature alarm indicator lamp
8	Fuel oil level gauge	25	Low transmission oil pressure alarm indicator lamp
9	Low brake pressure alarm indicator lamp	26	Power shutoff indicator lamp
10	Low fuel oil level alarm indicator lamp	27	Engine fault alarm indicator lamp (yellow)
11	Safety belt indicator light	28	Preheating indicator light
12	Parking brake indicator light	29	Air filter blockage alarm indicator lamp
13	Safety lock indicator light	30	Transmission oil rough filtration alarm indicator lamp
14	High beam indicator lamp	31	Fuel oil rough filtration alarm indicator lamp
15	Forward gear indicator light	32	Oil-water separation alarm indicator lamp
16	Neutral position indicator light	33	Mute indicator light
17	Reverse gear indicator light	34	Rear hood opening alarm indicator lamp



1 Center alarm indicator lamp (red)

Before starting, engine oil pressure and charging indicator lamps will be lit, this lamp will not alarm. When other faults occur, this lamp will flicker.



2 Left steering alarm indicator lamp (green)

The symbol will flicker when turning on the alarm lamp or left steering switch.



3 Right steering alarm indicator lamp (green)

The symbol will flicker when turning on the alarm lamp or right steering switch.

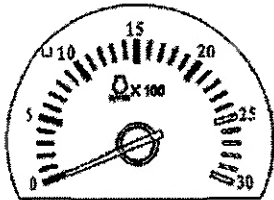

4 Engine speed indicator

This indicator displays present speed of the engine.

5 Working hourmeter

Display format of this meter is 00000.0h, and maximum display is 99999.9h. When the engine speed is no less than 400n/min, it keeps time and beats once every 6 minutes, and the memory stores once every minute.

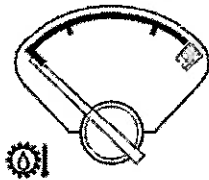

6 Oil temperature gauge of torque converter

When the pointer of oil temperature gauge is within the green range (40°C-120°C), oil temperature is normal. When the pointer reaches red area (120°C-140°C), the machine shall be stopped for check.

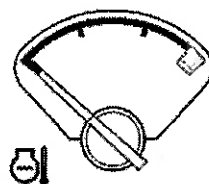

7 Water temperature gauge of engine

This gauge indicates temperature of cooling water of the engine. When the pointer of the water temperature gauge is within the green range (40°C-103°C), water temperature is normal.



**Attention: if the water temperature of the engine enters into red area, the machine shall be stopped for check.**

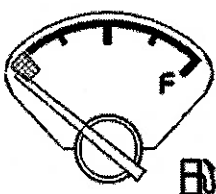

8 Fuel oil level gauge

This gauge shows residual amount of fuel in the fuel tank. When the pointer is within the red area (0~1/8), the machine needs to be filled with fuel timely.



- 9 Low brake pressure alarm indicator lamp (red)  
When the brake pressure is lower than the alarm point (0.4Mpa) or signal is grounded, it will alarm, this lamp will flicker and the buzzer will send sound.



- 10 Low fuel oil level alarm indicator lamp (red)  
When fuel oil level is lower than 1/8, this lamp will flicker.



- 11 Safety belt indicator light (red)  
When the safety belt is not fastened, the indicator light will be lit, to draw attention of the driver.



- 12 Parking brake indicator light (red)  
After the instrument is electrified, when manual braking is not cancelled, this light will flicker;



- 13 Safety lock indicator light (red)  
When rocker switch of safety lock is connected, and hydraulic circuit of working device is locked by safety solenoid valve, the indicator light will be lit.



- 14 High beam indicator lamp (blue)  
When the front combination lamp turns on high beam lamp, the symbol will be on.

- 15-21 Transmission gear state indicator light (green)  
It indicates state of transmission gear.



- 22 Low engine oil pressure alarm indicator lamp (red)  
If the starting switch is connected, this indicator lamp will be immediately lit; after the engine is started, this lamp will immediately go out. Otherwise, it means that lubricating oil level is too low or lubricating system breaks down, and the engine shall be immediately closed for check.



- 23 Charging alarm indicator lamp (red)  
The indicator lamp will be lit after opening the starting switch; after the engine speed is larger than or equal to 400n/min, the indicator lamp will go out. Otherwise, it means that the storage battery system breaks down, which shall be checked and repaired.



24 High coolant temperature alarm indicator lamp (red)

When the temperature of coolant of the engine is not less than 105°C, this lamp will be lit, center alarm lamp will be lit and buzzer will send sound.

If such situation occurs, the engine will be immediately closed for investigating reasons.



25 Low transmission oil pressure alarm indicator lamp (red)

After starting, when pressure is low, and switch is closed, signal will be grounded and symbol will flicker, buzzer will alarm; when the switch is disconnected, the symbol will not be lit.



26 Power shutoff indicator lamp (red)

When cutting off driving power of the transmission, this light will be lit.



27 Engine fault alarm indicator lamp (yellow)

When the engine breaks down and signal is grounded, the symbol will be normally on, and buzzer will alarm.



28 Preheating indicator light (yellow)

When cold starter is installed, the engine preheater works, and this light will be lit.

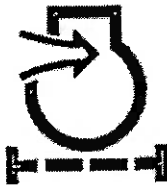

29 Air filter blockage alarm indicator lamp (yellow)

When the engine operates, if this indicator lamp is lit, it means that the air filter is blocked, and needs to be cleaned or replaced.



30 Transmission oil rough filtration alarm indicator lamp (yellow)

When water content of the transmission oil is higher than the set value on the switch, the switch will be closed, and the alarm symbol will be lit.



31 Fuel oil rough filtration alarm indicator lamp (yellow)

If the lamp is lit, it means that rough filter of fuel is blocked, and shall be cleaned or replaced.



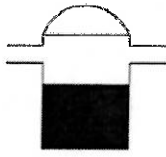

32 Oil-water separation alarm indicator lamp (yellow)

When the key is adjusted to ON, moisture in the oil-water separator is too much, and when switch is closed, the indicator lamp will be lit. When the lamp is lit, attention will be paid to water discharge of oil-water separator.



33 Mute indicator light (yellow)

When parts of faults occur, there will be sound alarm; when mute switch is connected, the sound alarm will stop, indicator light will be lit.



34 Rear hood opening alarm indicator lamp (yellow)

When door of rear hood of the engine is opened, this lamp will be lit.

Switch

1. Starting switch

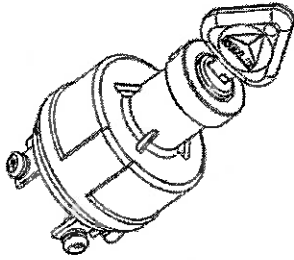



This switch is used to open or close electrical system and starting engine of the vehicle.

a)  position

Key can be inserted into or removed from this position. If the key is placed at this position, the circuit will be closed.

b)  position

When opening electrical system of the vehicle and the engine is under operation, the key will be at the position of 

c)  position

It is the position of the starting engine. During the starting period, key will be kept at this position. After the engine has been started, the key will be immediately loosened and it will automatically return to the position /.

2. Control panel of CD player /radio-cassette payer

This control panel is located at right side of the ceiling of the cab. Its operation method is shown in *Utilization and Operation Manual of CD Player / Radio-cassette Player*.

3. Combination (light) switch (L956F)

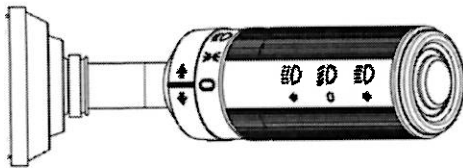

The combination light switch controls headlights, high and low beam, and turn signals, refer to page 76 for its location.

a) Lights

When the ignition switch is in the ON position, rotating this switch will turn on the front headlights, rear lights, and back-up lights.

b) High/low beam

When the ignition switch is in the ON position, pull combination light switch up toward the steering wheel to illuminate the front headlights (high beam). Turn the switch to “”, the font headlights (low beam) will be on. Pull the switch up and release it to switch between the “high beam” and “low beam”. Push the switch downward to illuminate the front headlights (high beam).

c) Turn signals

Push this switch forward towards the windshield and the left turn signals are on. Push this switch backwards toward the operator's seat and the right turn signals are on.



**Attention: when operating this switch, steering indicator light on the instrument panel will be lit at the same time. After steering operation is completed, this switch will be put back manually.**

4. Rocker switch

Rocker switch in the upper left of the cab is shown in the below figure.

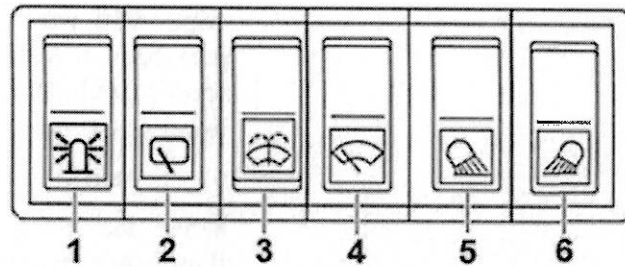

Rocker switch on the right side of the driver's seat is shown in the below figure.

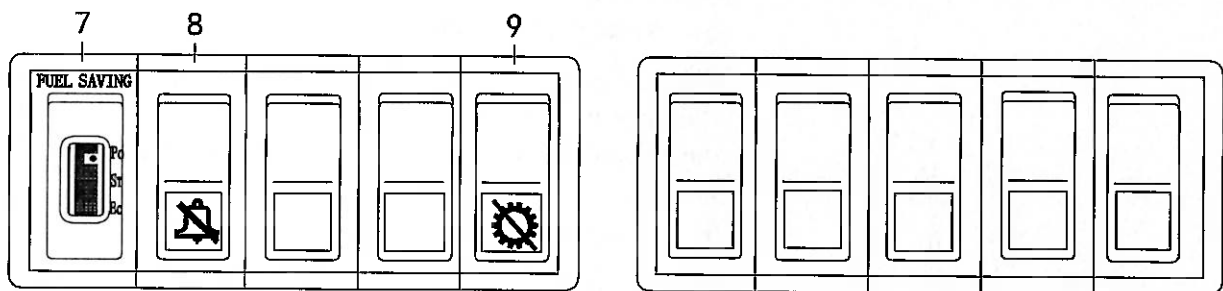

No.	Name	No.	Name
1	Switch of warning top light (option)	6	Switch of front illuminator
2	Switch of rear window wiper (option)	7	Oil-saving switch (option)
3	Switch of sprinkler	8	Mute switch
4	Switch of front window wiper	9	Switch of Power cut off (option)
5	Switch of Rear illuminator	10	Switch of caution light

1) Switch of warning top light (option)

When the lower end of the switch is pressed in, the warning top light in the top of the cab will glisten, which is used to cause attentions of other vehicles and pedestrians under emergency situation or situation that visibility is bad; when the upper end is pressed in, the light will go out.

2) Switch of rear window wiper (option)

When the lower end of the switch is pressed in, the window wiper will work; when the upper end of the switch is pressed in, it will stop working. Both high and low working speeds can be obtained due to different positions where the lower end is pressed in.

3) Switch of sprinkler

When the lower end of the switch is pressed in, the sprinkler motor will work, and water will be sprayed from water injection nozzle of the window wiper for cleaning front window in the cab; when it is loosened, the switch

will return automatically, and water spray will be stopped.

#### 4) Switch of front window wiper

When the lower end of the switch is pressed in, the window wiper will work; when the upper end of the switch is pressed in, it will stop working. Both high and low working speeds can be obtained due to different positions where the lower end is pressed in.

#### 5) Switch of Rear illuminator

When the lower end of the switch is pressed in, rear illuminator on the upper end of the cab will be lit; when the upper end of the switch is pressed in, the illuminator will go out.

#### 6) Switch of front illuminator

When the lower end of the switch is pressed in, front illuminator on the upper end of the cab will be lit; when the upper end of the switch is pressed in, the illuminator will go out.

#### 7) Oil-saving switch (Option)

Gear Ec, gear S<sub>T</sub> and gear Po of this switch are respectively corresponding to no-load, half load and full load construction conditions of the engine, which will switch over to save oil at these positions of scroll wheel.

#### 8) Mute switch

When the instrument panel sends buzzing sound for alarming, this switch can be pressed for closing sound alarm of the instrument panel.

#### 9) Switch of power cut off

Press the bottom end of switch, the power will be cut off; press the top end, the power is not cut off.

#### 10) Switch of caution light

This switch is on the left side of the instrument panel. When the lower end of the switch is pressed in, all steering lights will glisten at the same time, which are used under emergency situations for emitting warning light to cause attention of other vehicles and pedestrians. When the upper end of the switch is pressed in, all steering lights will stop glistening at the same time.



5. Rocker switch (export-oriented)

Rocker switch in the upper left of the cab is shown in the below figure.

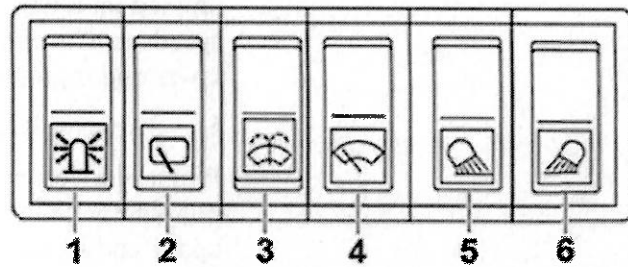

Rocker switch on the right side of the driver's seat is shown in the below figure.

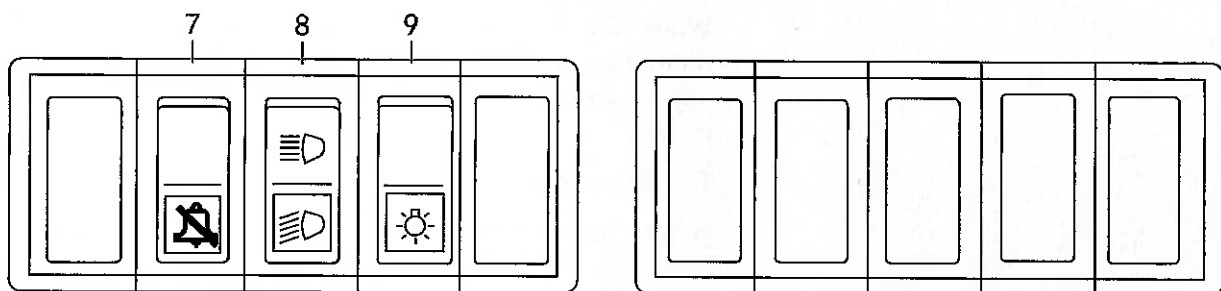

No.	Name	No.	Name
1	Switch of warning top light (option)	6	Switch of front illuminator
2	Switch of rear window wiper (option)	7	Mute switch
3	Switch of sprinkler	8	Switch of front headlamp
4	Switch of front window wiper	9	Switch of backlight
5	Switch of Rear illuminator	10	Switch of caution light

1) Switch of warning top light (option)

When the lower end of the switch is pressed in, the warning top light in the top of the cab will glisten, which is used to cause attentions of other vehicles and pedestrians under emergency situation or situation that visibility is bad; when the upper end is pressed in, the light will go out.

2) Switch of rear window wiper (option)

When the lower end of the switch is pressed in, the window wiper will work; when the upper end of the switch is pressed in, it will stop working. Both high and low working speeds can be obtained due to different positions where the lower end is pressed in.

3) Switch of sprinkler

When the lower end of the switch is pressed in, the sprinkler motor will work, and water will be sprayed from water injection nozzle of the window wiper for cleaning front window in the cab; when it is loosened, the switch will return automatically, and water spray will be stoped.

### 4) Switch of front window wiper

When the lower end of the switch is pressed in, the window wiper will work; when the upper end of the switch is pressed in, it will stop working. Both high and low working speeds can be obtained due to different positions where the lower end is pressed in.

### 5) Switch of Rear illuminator

When the lower end of the switch is pressed in, rear illuminator on the upper end of the cab will be lit; when the upper end of the switch is pressed in, the illuminator will go out.

### 6) Switch of front illuminator

When the lower end of the switch is pressed in, front illuminator on the upper end of the cab will be lit; when the upper end of the switch is pressed in, the illuminator will go out.

### 7) Mute switch

When the instrument panel sends buzzing sound for alarming, this switch can be pressed for closing sound alarm of the instrument panel.

### 8) Switch of front headlamp

When the lower end of the switch is pressed in, lower beams of front headlamp on the front frame will be lit.

When the upper end of the switch is pressed in, higher beams of front headlamp on the front frame will be lit.

When the lower and the upper end are not pressed in, the front headlamp will not be lit.

### 9) Switch of backlight

When the lower end of the switch is pressed in, the backlight and front and rear clearance lamps will be lit at the same time; when the upper end of the switch is pressed in, they will go out.

### 10) Switch of caution light

This switch is on the left side of the instrument panel. When the lower end of the switch is pressed in, all steering lights will glisten at the same time, which are used under emergency situations for emitting warning light to cause attention of other vehicles and pedestrians. When the upper end of the switch is pressed in, all steering lights will stop glistening at the same time.

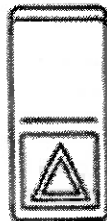

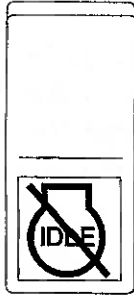

11) Switch of emergency acceleration (option)

When parking brake is not cancelled, the engine speed is limited to 1000r/min, so as to prevent burnout of parking brake caused due to driving at the time of parking, and play a role of protecting the parking brake. Under some special situations, in case of needing to raise the engine speed, long press lower end of the switch, and meanwhile step on the accelerator, so as to raise the engine speed.



**Attention: it can only be used under emergency situation.**

5. Switch of parking brake

This switch is on the right side of the driver's seat, which is used for controlling parking brake. When this switch is pressed in, parking brake will be implemented; when this switch is rotated clockwise, the parking brake will be cancelled after the button pops up.



**Attention: after the engine is started, this control lever must be pressed to cancel parking brake to prevent seriously damaging the parking brake.**

6. Switch of top light

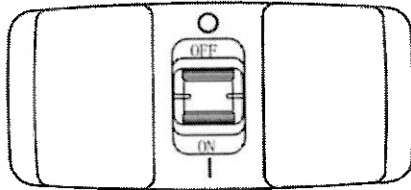

This switch is in the center of the cab. When it is pushed at the "ON" position, the top light will be lit; when pushing to "OFF" position, it will go out. When driving, the top light must be turned off.

7. Switch of electric fan

This fan is located in the upper part of the cab. When the lower end of the switch is pressed in, the speed is relatively small; when the upper end of the switch is pressed in, the speed is relatively big; when the switch is in the middle, the fan will stop revolving.

8. Horn button

The horn will ring after pressing the button in the center of steering wheel; the horn will stop ringing after releasing the button.

9. Cover of Sprinkler

This filler is on the front interior panel on the left side of the cab.

10. Standby plug and standby socket

This equipment is on the right side of the instrument panel. If illumination is not enough, standby lamps can be used via it.



**Attention: standby lamps must have protective device such as metal wire cover, and so on.**

11. Cigarette lighter

When the cigarette lighter is pressed, it will come back to the original position in a few seconds, and then it can be used.

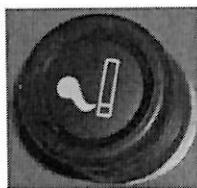



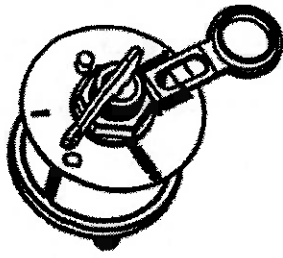

## 12. Master power switch

This switch is in the battery compartment. When the switch is adjusted to “O” position, the power of the vehicle will be closed; when the switch is adjusted to “I” position, the power of the vehicle will be connected. The master power switch will be closed when the vehicle will be parked for a long time.

## Steering wheel

Steering wheel is in the cab. The steering wheel is connected to the steering gear. When the machine is normally working, the steering wheel will be revolved by clockwise, the machine will turn right; when the steering wheel is revolved by anti-clockwise, the machine will turn left.

Its characteristics are as below:

- a) Revolving angle of the steering wheel is not equal to the steering angle of the machine. The steering angle of the machine will be enlarged until reaching to required steering position if continuously revolving the steering wheel.
- b) The faster when the revolving speed of the steering wheel, the faster the revolving speed of the machine.
- c) The steering wheel will not automatically return to the original position after steering and steering angle of the machine will be kept the same. Therefore, after the machine has completed steering, the steering wheel shall be revolved reversely so that the machine will drive along the horizontal and straight direction.

Control lever and pedal

1. Transmission control lever (Gear selector)

This lever is used to control the transmission gear and machine direction (forward/reverse).

Rotating the transmission control lever to the proper gear, pushing the transmission control lever forward or backwards, and modulating the accelerator pedal will allow the machine to achieve the desired operating speed and direction.

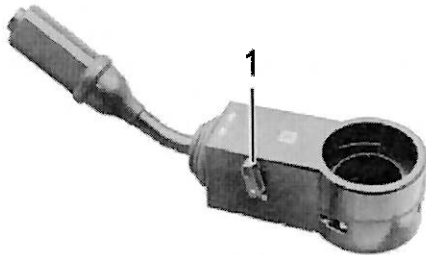

1 Neutral lock switch

Neutral lock switch: When this switch is set to "N" position, the transmission control lever will be locked in the neutral gear, to prevent the machine moving due to misoperation.

N = The transmission is electrically engaged in neutral. This position for the lever is in the center mode. The machine will not move in this mode.

F = The transmission is engaged in forward. Rotate the lever to position "1" for forward gear I, position "2" for forward gear II, position "3" for forward gear III, and position "4" for forward gear IV.

R = The transmission is engaged in reverse. Rotate the lever to position "1" for reverse gear I, position "2" for reverse gear II, and position "3" for reverse gear III.

Put the control lever in the "N" (neutral) position before starting the engine. Set the neutral lock switch to the "N" position after stopping the engine.

KD (Kick Down) function: Also called forced shift function. When engaged in forward gear II, and when moving forward into a pile of material, push the top (from left to right) of transmission control lever and the gear will be automatically reduced to forward I. When the bucket is full, turn the shift lever to reverse gear, and the gear can be automatically converted from forward gear I to reverse gear II. After stopping reverse motion and returning the lever to forward, and rotating the lever to gear II, the transmission will be in forward II gear. The KD function will be

removed once rotating the lever.

Start interlock function: Only when the transmission control lever is in neutral position can the engine be machine be started, which is a protective function of the system adopted by the machine.

2. Control rod fixing seat and control function(L968F domestic)

a) boom control lever (1)

Before and after there are four working positions, used to control the lifting of the boom, the median, descent and floating.

A = lift: boom lift.

B = middle position: the movable arm is kept in a certain position.

C = drop: boom drop.

D = floating: free movement of the movable arm under the action of the external force.

b) bucket lever (2)

There are three working positions for manipulating the bucket forward, median and tilt

A = forward: unloading.

B = A: bucket maintain at a certain position.

C = rear dump: receiving bucket.

The working device control lever also has the following functions:

c) automatic leveling function

The loader in the highest position after unloading, the bucket lever (2) in the backward position, the lever (2) by electromagnetic lock. Bucket in the process of collecting bucket, when in automatic flat position, manipulation rod

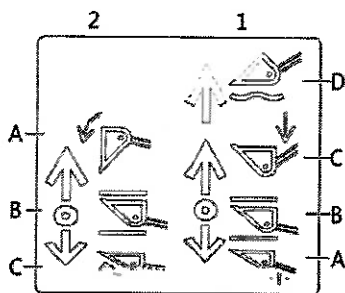
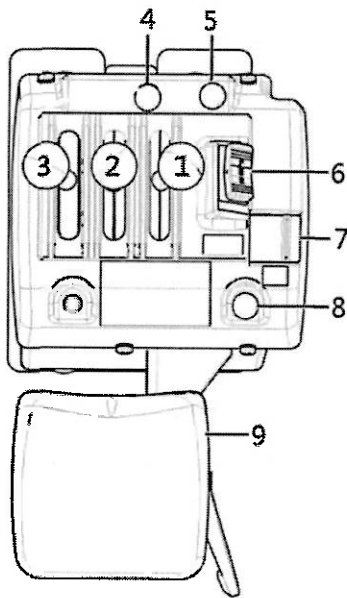

(2) automatic back in place, and then the moving arm lever (1) is arranged in the down position, working device into the ground, bucket automatic flat shovel in the material position, realize the automatic leveling function, improve the whole machine operation efficiency.

d) Lifting limit function

When the boom control rod (1) placed in a position to upgrade, control rod (1) by electromagnetic lock; when moving the arm lifting to the highest point, manipulation handle back in position, the lifting limit, avoid the damage of the working device of hydraulic impact.

e) automatic locking function

Loader in the flat land or scraping the flat ground and the boom lever (1) is arranged in the floating position, handle by electromagnetic lock, achieve boom automatic locking function; boom control rod (1) pull away from the floating position, control handle to automatically return bit and improve the work efficiency.

**⚠ ATTENTION**

**Do not use the floating position to put down the arm.**

f) third lever (3) (optional time)

If the machine is equipped with a wooden fork, the double action hydraulic outlet.

g) KD button (4)

Switch to auxiliary handle, the default for the neutral condition, when the vice handle direction switch is arranged in the f (or R) position, vice handle in move the second block (or back to second gear). At this time click on the button on the KD, block a switch to forward a block (or

back a block).

Once again press the KD button or change the direction of the block, the KD function is canceled, the vehicle back to the original block.

**⚠ATTENTION**

**Regardless of the current state in the control of the main handle or side handle, two KD button works.**

h) horn button (5)

Press this button, horns, release the button to stop ringing.

i) direction file F-N-R (6)

In order to be able to use the control rod fixed on the forward / backward function, we must first press the button 8 (3 seconds), the transmission gear box from the master handle to the control state of the auxiliary handle.

Press this switch forward = forward operation

The switch is in the middle position = neutral switch

Press this switch back end = reverse operation

j) control lever lock switch (7)

The control lever in neutral lock. In order to prevent the malfunction of the control rod (for example, in a transport machine), the control lever can be used to lock the function.

k) the direction of the gear (8)

**⚠ATTENTION**

**The rod seat is fixed on the shift function using a joystick, the steering wheel on the left side of the gear lever and the control rod seat is fixed on the rocker switch (G) must be in the neutral position.**

If the gear control lever is started on the left side of the

steering wheel, the shift function on the control rod fixing seat will not work, and the gear selector will decide the position of the shift control lever on the left side of the steering wheel.

1) arm pad (9)

The arm pad and the control rod fixing seat can be adjusted to the most comfortable operating position of the operator.

3. Control handle of working device (Exported)

This handle can be used to operate the bucket and the boom. It has four working positions in front and in the rear, for controlling lifting, neutral position, descending and floating of the boom; it has three working positions on the left and right sides, for controlling forerake, neutral position and rear reverse of the bucket.

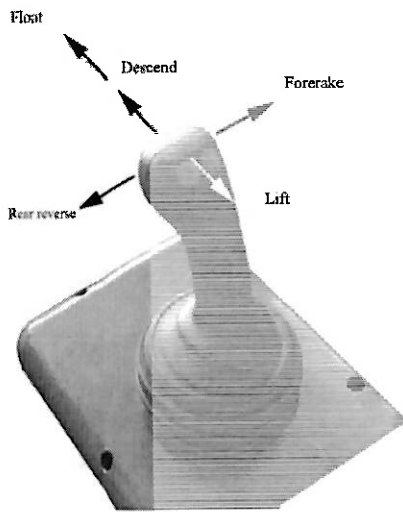

a) Bucket

Rear reverse: collect the bucket.

Neutral position: the bucket is kept at certain position.

Forerake: unloading.

b) Boom

Lift: the boom is lifted.

Neutral position: the boom is kept at certain position.

Descend: the boom is descended.

Float: boom moves freely under external force.

c) Quick change device

The button on the left side of the control handle controls extension of piston rods of double-rod hydraulic cylinder, and connects working accessories; the button on the right side controls retraction of piston rods of double-rod hydraulic cylinder, and disconnect working accessories.



**Attention: it is strictly forbidden to disconnect the working accessories during the operation.**

In addition, the control handle of working device has the following functions:

## d) Automatic flat function

After the loader unloads materials in the highest position, place the control handle in the position of rear reverse, and the control handle will be electromagnetically locked. In the process of retraction of the bucket, when it is in an automatic flat position, the control handle will automatically come back to the neutral position. Then place the control handle in the position of descending and place the working device on the ground, and the bucket will become flat automatically and be in the position of spading, so as to realize the automatic flat function, thus increasing operation efficiency of the whole machine.

## e) Lifting limit function

When the control handle is placed in the position of lifting, the control handle will be electromagnetically locked; when the boom is lifted to the highest point, the control handle will come back to the neutral position, so as to realize lifting limit, thus avoiding damage to the working device caused due to hydraulic shock.

## f) Automatic locking function

When the loader is leveling the land or slicking the ground, place the control handle in the position of floating, and the control handle will be electromagnetically locked, so as to realize automatic locking function of the boom; pull the control handle away from the position of floating, and the control handle will automatically come back to the neutral position, thus increasing operation efficiency.



**Attention: do not use the position of floating to place the boom.**

### 4. Brake pedal

Brake pedal is used to brake the vehicle, which is shown in "P88 control mechanism and instrument".

### 5. Accelerator pedal

This pedal is used to control accelerator of the engine, which is shown in "P88 control mechanism and instrument". The speed of the engine can be regulated between idling and full speed.

### Locking rod of cab door

Outdoor locking rod: when the left and right doors are opened to 180°, the alignment pin will contact lock catch outside of the cab and be locked, the door will be locked outdoor, and control lever of the alignment pin is in the middle of the door. If the rod is drawn downwards, the locking will be cancelled.

Indoor locking rod: it will be automatically locked after closing the door; key will be inserted outside of the cab and taken out after revolving by 180° along the clockwise direction. The door can be opened by pulling the door and pressing the door lock by hand. If the rod is drawn upwards in the cab, the door will be opened.



**Attention: locking of cab door has two states including semi-locking and full locking. The vehicle can be locked under two states. However, it can be sealed only when full locking state. Therefore, if leaving the cab for a long time, the cab door must be completely locked.**

### Emergency exit

The cab has two emergency exits: door and rear window. No matter the rear window is fixed or slide-type, the hammer hanged on the rear side in the cab shall be used to break glass to escape from the cab.



**Attention: it can only be used under emergency situation.**



Fuse

**! Attention**

- Before replacing fuse, the starting switch must be closed. The fuse is used to protect electric equipment and cable to prevent burning. If the fuse is corroded or loosened, it shall be replaced in time.
- When replacing, specification of the fuse will be the same.

Fuse box is located in the hood in the bottom left of the instrument desk of the cab. The box can be opened for checking fuse after rotating the rotary switch.

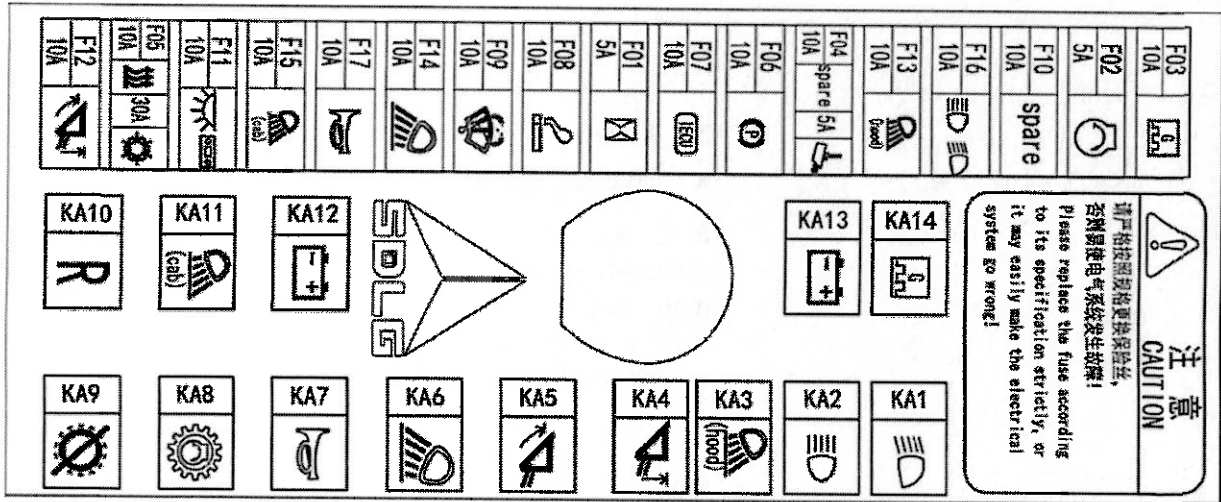

No.	Specifications	Application/Circuit	No.	Specifications	Application/Circuit
F01	5A	Hourmeter	F10	10A	-
F02	5A	Starting switch	F11	10A	Radio/top light
F03	10A	Flasher	F12	10A	Bucket proximity switch
F04	10A	-	F13	10A	Switch of Rear illuminator (engine hood)
F05	30A/10A	Air conditioning/warm	F14	10A	Switch of front
F06	10A	Switch of brake taillight	F15	10A	Switch of Rear illuminator (cab)
F07	10A	I-ECU (Instrument-electronic)	F16	10A	Switch of high beam lamp
F08	10A	Cigarette lighter	F17	10A	Horn
F09	10A	Switch of front window wiper/sprinkler			

### Air conditioning

#### 1. Panel appearance

Panel of the air conditioning is on the right side of the driver's seat.

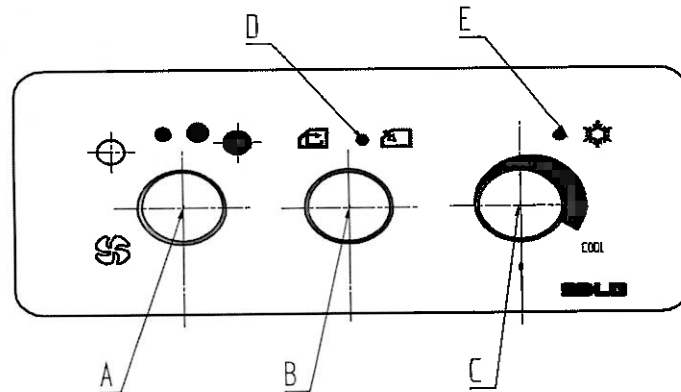

#### 2. Function of operating components

##### A. Blowing rate switch

It is system switch, and controls rotation speed of evaporating fan. It is divided into three gears including high, medium and low gears, and power switch, so as to choose proper blowing rate and open or close the air conditioning system.

##### B. Fresh air change-over switch

It controls operation of fresh air actuator, and controls air intake through inner and outer circulation.

##### C. Cooling starting change-over switch

Through clockwise rotation, it opens cooling system and regulates refrigerating capacity.

##### D. Fresh air opening indicator light.

##### E. Cooling starting indicator light.

#### 3. Operation method

##### a) Cooling

- Start the engine.
- Turn on the blowing rate switch, and you can feel that the system has started to be in the blowing state. Turn on cooling change-over switch to cooling gear, and then the cooling indicator light is lit, and the system is in the cooling state.
- Rotate the blowing rate switch, and choose different gears, so as to obtain air volume at three gears including high, medium and low gears.

- When lowering the temperature to the required one, slowly rotate the cooling starting change-over switch anticlockwise until the indicator light goes out and the compressor stop working, and at this time, the temperature in the cab is the set temperature. When the indoor temperature is higher than this temperature, the indicator light will be lit, the compressor will automatically start, and the system will start cooling; when the indoor temperature is lower than this temperature, the indicator light will go out, and the system will stop working

b) Heating

- Before use, adjust the cooling starting change-over switch to “off” state first.
- Start the engine, and rotate switch of hot water valve clockwise.
- Turn on the blowing rate switch of the fan, choose a gear, and regulate the blowing rate to the required one.



**Attention: please close hot water valve at the time of cooling in summer, and close temperature control switch at the time of cooling in winter.**

Seat adjustment

1. Suspension setting stroke

The machine is equipped with mechanical suspension seat. Full suspension mechanism on the seat chassis is protected by rubber sleeve to prevent erosion of external sewage and pollutant. Suspension setting stroke is 70mm.

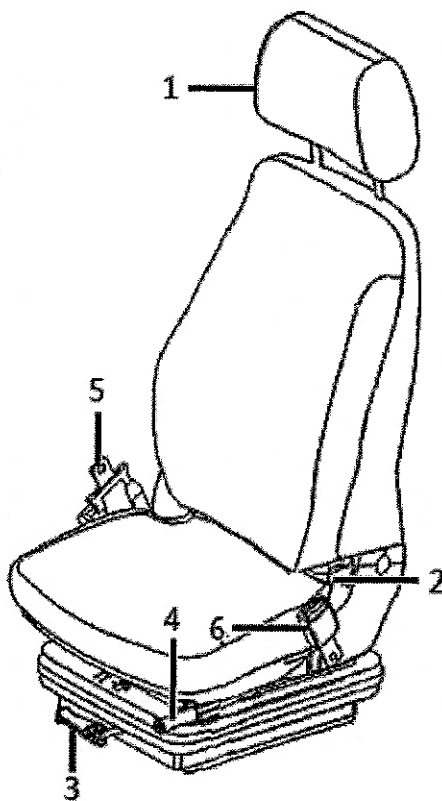

- 1 Headrest
- 2 Back adjustment handle
- 3 Bearing adjustment knob
- 4 Front and rear adjustment handle
- 5 Spring bolt
- 6 Locker

 **Warning**

- When adjusting driving seat, the vehicle will be parked in safe place and the engine will be closed.
- Before starting operation or replacing driver, the driving seat will be adjusted.
- Your back must lean on the back of the seat to completely stamp brake pedal.



### 2. Bearing adjustment

Adjusting knob 2 is in the downside center in the front of the seat, operator will rotate the knob by anti-clockwise to reduce rigidity of vibration reduction; if rotating the knob by clockwise, the rigidity of vibration reduction will be increased. Operator can achieve infinitely variable control between 50 and 120kg by manually rotating the adjusting knob of vibration reduction rigidity knob until operator feels comfortable according to its weight.

### 3. Front and back adjustment

Front and back adjustment handle 4 is on the left side of the seat. It can be adjusted by lifting up the front and back adjustment handle along the front and back directions of the seat until it reaches ideal position. It will be automatically locked after releasing the handle.

### 4. Backrest angle adjustment

The backrest adjustment handle 2 is lifted up, backrest will be moved until the backrest angle is suitable, and then the handle will be loosened for locking the backrest angle.

### 5. Height adjustment

Seat height has three position heights that are divided into three card positions. Operator can adjust as per demand. When adjusting, both hands will hold the substrate below the cushion and stably pull up. The seat will contact the card position in the lifting process and cracking sound will be heard. At this moment, the seat will be fixed at this position if loosening the hand. If the seat position is adjusted to the highest position, the seat will be descended to the lowest position after pulling up and pressing. Adjustment scope is 60mm.

### 6. Adjustment of headrest height

Hold the seat headrest with both hands, up-pull or press downwards emphatically stably to adjust the headrest height of the seat.

#### Use of safety belt (when installed)

If the seat is equipped with safety belt, driver shall tie safety belt when operating the machine. Before using the safety belt, attrition rate and fastness degree of the safety belt shall be checked. If necessary, the safety belt will be replaced in time.

The length of the safety belt shall be adjusted before use to guarantee the safety belt can have safety guarantee function and certain comfort. Position of spring bolt of the safety belt at the safety belt can be moved to adjust length of the safety belt. The locker of the safety belt is on the left side of the seat. The locker will lock the spring bolt if the spring bolt of the safety belt is inserted into opening of the locker.

There is a red button near the opening of locker. The spring bolt will jump out of the locker after pressing the red button. Before using the safety belt, locker of the safety belt will be checked to confirm whether it is normally locked and loosened or not.

#### Rearview mirror

Rearview mirror is located on left side and right side of the cab. Before operating the machine, the rearview mirror must be adjusted. Elevation angle of the rearview mirror will be adjusted after revolving rearview mirror to guarantee driver has good back view.

#### Fire extinguisher

Installation hole for installing holder of the fire extinguisher has been reserved in the left rear side of the seat in the cab. Fire extinguisher will be installed in accordance with national laws and local requirements. (All distributors of the company have prepared holder of fire extinguisher and fire extinguisher for selection).

#### 1. Key points for using fire extinguisher:

- a) Stand on weather side and keep suitable distance (two to three meters).
- b) Remove the safety pin.
- c) Hold the sprayer nozzle by one hand; press the handle by the other hand.
- d) Align at the root of fire source.

#### 2. Daily check and instructions of fire extinguisher:

- a) Pressure of the fire extinguisher will be checked for once every half a year. If the pointer of the pressure gauge is in the red area, the fire extinguishing agent shall be immediately supplemented or new fire extinguisher shall be replaced.
- b) Hydraulic test shall be conducted every five years or before supplementing fire extinguishing agent, only after it passes the test, it can be used.
- c) The fire extinguisher is mainly used for preliminary fire disaster.

#### Key

The loader is equipped with two sets of keys (two keys per set):

1. Key of starting switch of the engine (3)
2. Keys of hood doors (left and right) and the cab door (2)

Bucket

 **Attention**

When it is changed to another accessory device, hole of lock pin of new accessory device shall be cleaned and lubricated.

 **Warning**

**Crushing danger.**

Falling accessory device may cause serious personal casualty. The holder of accessory device must be locked correctly before operation.



## Breaking-in of new vehicle

New vehicle must conduct breaking-in. Load will be gradually increased from idling to conduct adequate running-in for all friction parts to prolong lifetime of the machine. New vehicle will go through breaking-in for ten hours. The following provisions will be abided by during the breaking-in period:

1. After the machine is started, it will operate at low speed for five minutes so that the engine will conduct adequate preheating operation.
2. The engine cannot suddenly speed up at the preheating stage.
3. Sudden starting, sudden speed-up, sudden steering and sudden braking will be avoided except for emergency situation.
4. When the machine is driving when idling, all gears will be conducted from low speed to high speed. Stable left and right steering and braking shall be conducted in the driving process.
5. During the period of breaking-in, forward gear, reverse gear and other gears shall be arranged for uniform breaking-in.
6. The loader shall be loaded with loose materials during the period of breaking in. operation cannot be too rough and urgent. Loading weight cannot exceed 70% of rated weight. Driving speed cannot exceed 70% of maximum speed.
7. Attention will be paid to lubrication situation of the machine. Lubricating oil will be replaced or added as per stipulated time.
8. Attentions must be paid to temperature of transmission, torque converter, front and rear axles, wheel hub and drum brake. If there is overheating phenomenon, reasons shall be figured out and removed.
9. Fastening situation of bolts and nuts of all parts will be checked.

The following work shall be conducted after new vehicle has experienced ten hours of breaking-in and the period of breaking in is due:

10. Fastening situation of bolts and nuts of all parts will be comprehensively checked. In particular, bolt of air cylinder cover of diesel engine, bolt of air exhaust pipe, fixed bolts of front and rear axles, rim nut and connecting bolt of transmission shaft shall be checked for once.



11. Rough and refined engine oil filters and fuel filter will be cleaned.
12. Tightness degree of fan belt and belt of engine will be checked.
13. Electro-hydraulic proportion and reserve of storage battery will be checked. Connector of the storage battery will be tightened.
14. Oil level of the transmission will be checked in accordance with "P165 oil level check of transmission oil of transmission".
15. Leakproofness of hydraulic system and braking system will be checked.
16. Connection, fixation and flexibility of all control levers will be checked.
17. Temperature and connection situation of all parts of the electric system, power supply state of the generator and working situations of instrument, lamp and steering signal will be checked.

After the period of breaking in is due, the following work shall be conducted too:

18. Filter screen of oil sump of the transmission and filter element of oil filter of the torque converter will be cleaned.
19. Element of scavenge filter of hydraulic oil tank will be cleaned.
20. Engine oil will be replaced, which is shown in "P150 replacement of engine oil". In addition, the engine will be maintained in accordance with *Operation and Maintenance Manual of the Diesel Engine* enclosed with the machine.

### **Use of the loader**

#### **Instructions for use**

1. Diesel used by the loader must be pure and clean. Diesel mark number shall comply with requirements.
2. Hydraulic transmission oil used by the transmission and torque converter and hydraulic oil used by the hydraulic system must be clean.
3. The loader must be regularly maintained and lubricated in accordance with provisions.
4. After the engine is started, after water temperature is 55°C and braking pressure is 0.4MPa through idling, it will drive again.
5. In general, when the air temperature is less than -5°C, the engine will be preheated before starting.



6. The vehicle need not be parked and brake pedal need not be stamped when changing forward gear in the driving process. The accelerator will be loosened from low speed to high speed and the transmission handle will be operated. Then, accelerator will be stamped; when changing from high speed to low speed, the accelerator will be loosened and gear will be changed after the speed is reduced slowly.
7. When the boom and rotating bucket reach required position, control handle of the working device shall be returned to the middle position.
8. Driving towards front and the rear directions will be changed when the vehicle is parked.
9. The machine can be operated under full load only when the water temperature of the engine is higher than 60°C and oil temperature of the engine is higher than 50°C. When operating, water temperature and oil temperature of the engine will not be more than 95°C, oil temperature of the torque converter will not be more than 120°C. If the temperature is more than the allowable value, the vehicle shall be parked for cooling.
10. The bucket cannot be lifted to the highest position for transporting materials. The lower hinge joint of the boom shall be about 400mm to 500mm above the ground when transporting materials to guarantee stable driving.
11. As for the diesel engine used by the loader, the power will be decreased with the increase of altitude, environmental temperature and relative temperature. Therefore, user must pay attention to local environment and obtain actual power of the diesel engine under local situation when using the loader.

## **Starting**



### Comprehensive check before starting

1. Bottom and periphery of the vehicle will be checked to observe whether bolt is loosened or not and whether there is dirt, oil leakage, leakage of coolant and component damage or not. State of accessories and hydraulic parts will be checked.
2. Check before starting:
  - a) Oil quantity of fuel tank will be checked, which is shown in "P184 table of oil selection".
  - b) Oil quantity of hydraulic oil tank will be checked, which is shown in "P184 table of oil selection".
  - c) Oil quantity of engine sump will be checked.



- d) Water level of the water tank will be checked after opening the water tank cover.
- e) Tightness of all oil pipes, water pipes, gas pipes and all parts will be checked.
- f) Tightness of pipelines and surrounding areas of hydraulic system will be checked.
- g) Wiring of the storage battery will be checked;
- h) Tyre pressure will be checked. Inflation pressure of tyre is shown in "P86 and P87 technical performances and parameters".
- i) All control handles will be checked to confirm whether they are flexible and placed in neutral position or not.
- j) Seat position will be adjusted to so that you can comfortably control. Seat adjustment is shown in "P118 seat adjustment".
- k) Safety belt of the seat will be checked (if have) and various safety devices will be checked;
- l) All control levers and caution lights can be used normally.
- m) The engine can be started after confirming that battery disconnecting switch and frame locking rod have been opened through confirmation; the wheel has not been blocked, covers of all inspection ports and engine hood have been closed and fastened, fuel is enough and all parts are normal.

## Engine starting

1. Instructions for starting the engine:
  - a) The control handle of the working device of the loader must be at the neutral position, transmission control handle must be at the neutral gear and switch is at the original position before starting.
  - b) The accelerator cannot be adjusted to the largest position at the starting moment to prevent damaging parts of the diesel engine.
  - c) The engine will be started in accordance with correct steps for starting the engine.
2. Steps for starting the engine:
  - a) Transmission control handle on the left side below the steering wheel is at the neutral gear.
  - b) Starting key is rotated to the position of “” as per clockwise and master power switch is connected.
  - c) Accelerator is stamped slightly, and the engine can be started after rotating to the position of  as per clockwise direction. The key of starting switch will be loosened after starting, the key will automatically return to the position of “”. Starting time per time cannot be more than 5 to 10 seconds (continuous working time of starting motor shall not be more than 15 seconds).
  - d) If it cannot be started, and it need be started again, the interval shall be more than 1 minute. If the engine cannot be started for three times in succession, the engine can be started after figuring out reasons and removing faults.

## After starting the engine

1. Honk and release parking brake.
2. The engine will be operated at low speed. If the pressure gauge of engine oil cannot point to normal range within ten seconds, the engine can be started after figuring out reasons, otherwise, it will cause engine fault.
3. When the engine oil pressure fails to reach stipulated value, if the speed of the engine is too fast, the turbocharger will be damaged.
4. To increase temperature of hydraulic elements, the control handle of the working device will be used repeatedly so that hydraulic oil through preheating will flow circularly in all hydraulic oil cylinders and hydraulic pipelines.

5. After the diesel engine has been started, it will go through idling for several minutes to guarantee adequate lubrication (such as turbocharger, and so on); then, the engine will speed up gradually to 1,000r/min-1,200r/min for partial load operation. In the operation process, attention must be paid to change of instrument readings.
6. The engine cannot be operated at high speed in the neutral gear or at low speed for over 20 minutes in succession.
7. If necessary, the engine will be operated at the neutral gear. In addition, load will be constantly added or the engine shall be operated at medium speed.
8. Accessory device will be checked to confirm whether it has been locked solidly or not by using the method that is used to press the accessory device to the ground.

### Driving

#### Starting

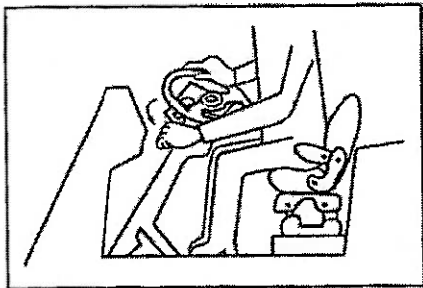
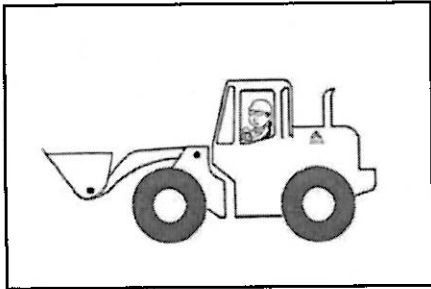

1. To prevent accident, unrelated personnel cannot be on the vehicle or surrounding the vehicle before driving and the vehicle must be under control all the time.
2. The boom is lifted, bucket is reversed and driving post will be kept.
3. Transmission control handle is placed at the forward gear I or reverse gear I.
4. The brake pedal will be stamped, parking brake switch is released to cancel parking brake.
5. The brake pedal is loosened, accelerator pedal is stamped slowly, the loader drives forwards or backwards.
6. Driving safety can be guaranteed only when the vehicle pressure is higher than emergency brake pressure (0.4MPa).
7. The bucket cannot be lifted to the highest position for transporting materials. The lower hinge joint of the boom shall be about 400mm to 500mm (16in-20in) above the ground when transporting materials to guarantee stable driving.

Conversion among transmission, forward and reverse

 **Attention**

- **It is strictly prohibited to drive at high speed when driving on slope or pavement with poor road condition.**
- **Suitable gear will be selected before leaving the slope and it is prohibited to change gear in the process of leaving the slope.**
- **It is strictly prohibited to exceed the stipulated speed when leaving the slope. Brake pedal can be used (left brake pedal cannot be used if double brake pedals are installed) to reduce the speed.**

1. When changing the gear, the accelerator will be stamped properly to prevent the drive system from obtaining too large impact.
2. To provide comfort for driver and prolong lifetime of driving element to the largest extent, change of driving direction will be conducted after the vehicle is parked (from forward to reverse and from reverse to forward).
3. If gear is changed when driving, the vehicle needn't be parked and brake pedal needn't be stamped. The accelerator will be loosened and gear control lever will be controlled for changing from low speed to high speed, and then the accelerator will be stamped. When changing from high speed to low speed, the accelerator will be loosened and gear will be changed after the speed is reduced slowly.

**Steering**

 **Warning**

- **When the vehicle is under high speed state, sudden steering or steering on abrupt slope is prohibited.**
- **When driving along the straight line, if the engine is closed, the vehicle cannot steer.**

1. The vehicle can make a turn when the steering wheel is rotated towards change direction when driving.
2. The vehicle is centered on the swivel pin. Front and rear frames will bend and steer.

## Braking

### Warning

Vehicle when driving cannot use parking brake switch to reduce speed of vehicle or park the vehicle except for emergency (such as: service brake loses effect). If it has been used, friction plate will be checked and replaced after cancelling brake.

1. Unless it is necessary, the feet cannot be placed on the brake pedal.
2. Unless it is necessary, the pedal cannot be stamped repeatedly.
3. If the transmission need be at the neutral gear when braking, the rocker switch of power shutoff will be pressed to shut off transmission output power. When loosening the rocker switch of power shutoff, the machine will automatically recover to the gear used before braking.
4. When leaving the slope, it is prohibited to close the engine. The gear control lever cannot be placed at the neutral gear.

## Parking

### Parking steps

1. Speed of the engine is reduced.
2. After the vehicle is parked stably by loosening the accelerator pedal and stamping brake pedal, all gear control levers will be adjusted to the neutral gear.
3. Bucket or other working device will be descended to the ground and placed horizontally.
4. The vehicle is parked safely. Parking brake switch is pressed so that the machine is under braking state.
5. The machine is parked on the flat ground. There shall not be rockfall, landslide or flood danger. If the machine must be parked on inclined slope temporarily, the wedge block shall be used to block the wheel to prevent machine from moving.

## Steps for stopping the engine

 **Attention**

**Before the engine is cooled, it is prohibited to draw up the shutdown control flexible axle to shut down the engine.**

1. To maintain lubrication and cooling of turbocharger, the engine will be operated under idling for about five minutes before parking so that all parts will be cooled uniformly.
2. Press switch of parking brake.
3. Rotate the key to the position of “○” and keep it properly after taking out.

## Leave the loader

1. Ladder and handrail will be used when getting off the vehicle. Operators need face to the loader when getting off. It is prohibited to jump off.
2. If the engine is under operation, attentions are required when leaving the cab. Operators cannot unconsciously rotate the steering wheel.
3. The structure of the engine will be checked to confirm whether there are fragmental substances or not. If have, they shall be immediately removed to prevent fire disaster.
4. All flammable substances surrounding the vehicle will be removed to prevent fire disaster.
5. Door, window and side door will be locked and keys will be taken out and taken away.

The following work must be conducted after daily operation is completed

1. Fuel oil reserve will be checked.
2. Oil level and cleanliness situation of the engine sump will be checked. If the oil level is too high and it is thin, reason shall be figured out and removed.
3. All oil pipes, water pipes and all parts will be checked to confirm whether they have any leakage phenomenon or not.
4. Fixation and seal of transmission, torque converter, hydraulic oil pump, steering gear, front and rear axles will be checked. Whether they are overheated or not.
5. Fixation of rim bolt, bolt of transmission shaft and all pins will be checked to confirm whether they are loose or not.
6. Whether working device is normal or not;

7. Appearance and pressure of tyre will be checked.
8. Grease will be injected into all lubricating points of the working device.
9. Appearance of the machine and soil and sundries in the bucket will be cleared.

## Operation

### Operation preparation

Working site will be cleared, pit will be leveled and barriers that will damage and hinder operation such as sharp rock will be eradicated.

### Operation way

1. Loading operation
  - a) When the loader cooperates with truck, especially when the transportation distance is relatively far, operation efficiency will be enhanced.
  - b) When operating through cooperation, the loader will shovel material and the truck will be responsible for long-distance transportation and unloading.
  - c) Loading ways generally include two ways:
    - Crossing loading

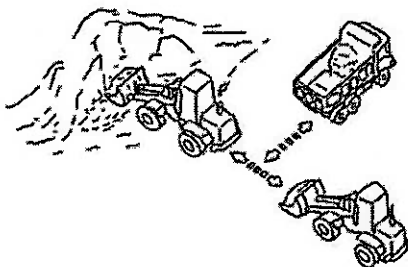

The loader will face to material pile and be filled with materials. The loader will back up, and then the dump truck will be between the loader and the material pile. This loading method requires the shortest time, therefore, it can effectively reduce circulating time to the largest extent.

- V-type loading

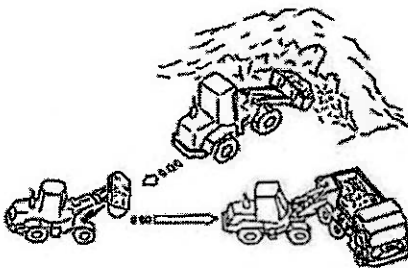

The position of the dump truck will be set so that the angle between it and the reverse direction of the loader is about 60°. After the bucket is filled with materials, the loader will return and drive towards the dump truck after rotating by certain angle. The smaller the V-type angle when the loader is operating, the higher the working efficiency.

2. Shoveling operation

- a) Shovel soil block or aggregated rock

When shoveling soil block or aggregated rock, the vehicle will be pointed to the material pile and operation will be conducted in accordance with the following requirements:



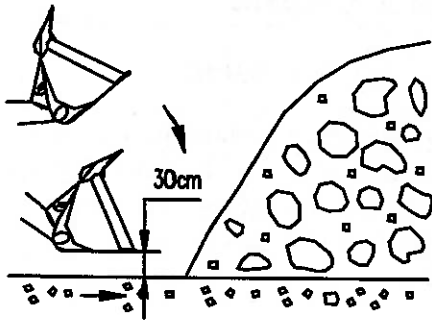

- When lifting the bucket down when the vehicle is driving forward, the vehicle shall be parked when the bucket is 30cm above the ground and then the bucket will be lifted down slowly.
- If the bucket collides with the ground, the front wheel will leave the ground and slide.
- The speed shall be immediately reduced in front of the material pile. When completing variable speed, accelerator pedal shall be stamped and the bucket shall be inserted into the material pile.
- If it is crushed aggregate, the bucket will be kept horizontal. If it is stone, the bucket shall have an angle.

 **Attention:**

Stone cannot be under the bucket, which will make the front wheel leave the ground and generate slipping. The load shall be in the center of the bucket. If the gravity center is on one side of the bucket, balance will lose.

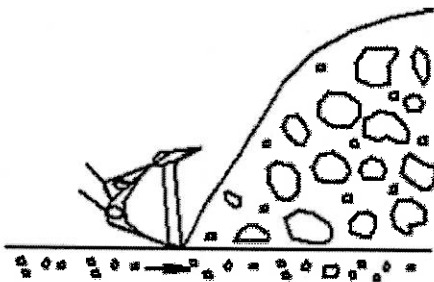

- When the bucket is being inserted into the material pile, the boom shall be lifted so that the bucket will not be inserted too deeply. Tyre will generate enough traction force by enhancing the boom.

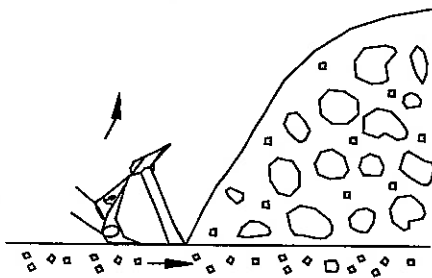

- When the bucket has enough materials, the control handle of the bucket will be controlled to collect the bucket so that it is filled with materials.

 **Attention:**

When the bucket is inserted into the material pile or it is excavating, the front wheel will leave the ground and generate slipping.

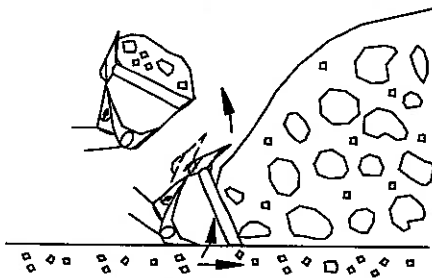

- If the load in the bucket is too large, the bucket shall be rapidly reversed and collected and excessive load will be removed to prevent material from scattering when transporting.

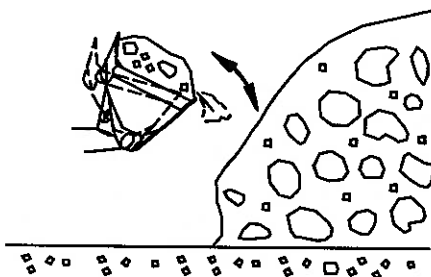

b) Spading material on flat ground

 **Attention**

**When conducting shoveling operation, the two sides of the bucket shall be uniformly fed and try to avoid conduct lateral feeding operation. The loader will be directly pointed to the front and front and rear frames cannot have angle.**

In the process of spading material on the flat ground, the edge of the shovel will be slightly pointed to the ground as shown in the figure. However, load cannot be centralized on one side to cause imbalance. Gear I will be used to carefully operate.

- The edge of the shovel will be slightly pointed to the bottom.
- When the vehicle drives forward, the control handle of the boom will be controlled so that the boom will be descended to suitable position and thin soil can be removed in the execution process.
- When the vehicle drives forward, the control handle of the boom will be slightly moved forward and backward to reduce resistance when the vehicle drives forward.

3. Handling operation

Independent handling can be adopted under the following situations:

- a) Truck cannot be used under too soft pavement and unlevelled road.
- b) If the distance is within 500 meters, it is not economical to use truck.
- c) Handling speed is determined as per handling distance and pavement condition.
- d) To guarantee safety, stability and good sight line when handling, the bucket shall be lifted to extreme position (the bucket contacts the limited block of the boom) and the lower hinge joint of the boom is at the transportation position (about 400mm to 500mm above the ground).

4. Unloading operation

- a) After the truck or the goods yard dumps materials, the boom shall be lifted to the bucket position (when inclining to the largest position) until it cannot contact the truck bed and material pile. Control handle of the bucket will be controlled so that the bucket inclines and unloads. All or part of materials can be unloaded via control over the control handle. Action need be

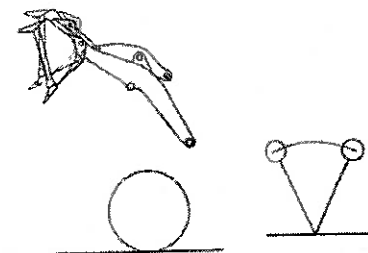

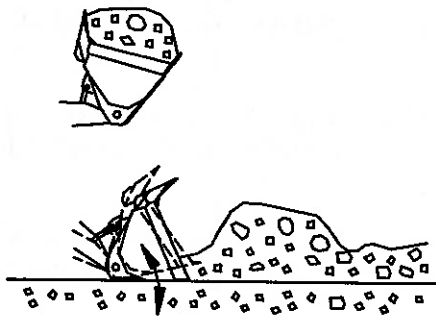

- slow when unloading to reduce impact of the material for the truck.
- b) When material is adhered to the bucket, the control handle of the bucket can be controlled repeatedly to make the bucket incline forwards or backwards and make material fall via bucket vibration.
  - c) After unloading operation is completed, the bucket will be placed horizontally and the control handle of the boom will be controlled to descend the boom for next cyclic operation.

5. Handling operation

**! Attention**

**Close attention will be paid to oil temperature of working hydraulic oil in the process of handling operation. If the oil temperature is too high, the machine shall be shut down and start to work again after oil temperature is reduced.**

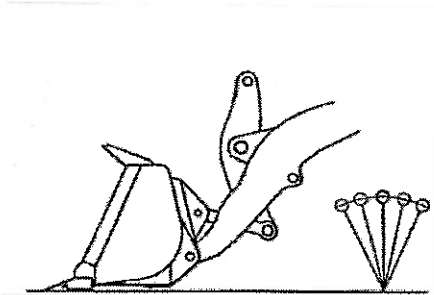

The bucket will be pasted to the ground and the vehicle will move forwards by stamping the accelerator. When discovering that the vehicle is blocked, the boom can be slightly lifted and move forward. The control handle shall be conducted between lifting and descending when controlling the lifting and descending of the boom. The boom cannot be lifted or descended to any position to guarantee successful handling operation.

6. Leveling operation

The bucket will be overturned completely so that the cutting board contacts the ground; as for hard pavement, the control handle of the boom shall be placed at the floating position. As for soft pavement, it shall be placed in the center; after connecting the reverse gear, the cutting board will be used to level the ground.

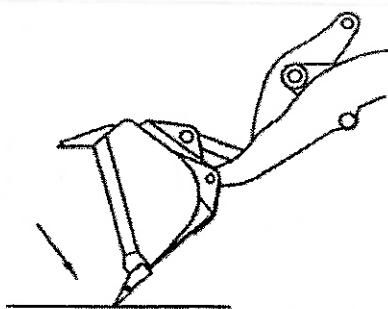

7. Traction operation

**! Warning**

- **Before traction, parking brake must be used and the wheel will be blocked to prevent the loader from rolling.**
- **When dragging, you must be very careful to avoid serious injury and fatal injury.**

- a) If possible, the engine of the dragged vehicle shall be kept operating so that the brake and steering can be operated.

- b) If the engine of the dragged vehicle cannot be started, or pressure for releasing parking brake cannot be established due to other reasons, it can be loosened by using mechanical method such as dismantling front and rear transmission shafts. When steering cannot be operated, the steering oil cylinder will be dismantled.



Attention: this method is just for allowing traction. Parking brake shall be immediately recovered after traction is completed.

- c) Connecting hole on the rear frame inside the rear wheel is just used for lifting and binding and cannot be used for traction.
- d) If the vehicle to be dragged does not have brake, soft traction cannot be used, but fixed traction rod. The traction pin 1 will be inserted into balance weight 2 and the traction rod will be connected to the traction pin on the rear part of the loader.
- e) If the vehicle to be dragged cannot steer or brake, anyone cannot board the fault vehicle.
- f) Guide rope or traction pin will be checked to confirm whether they have enough strength to bear weight of the dragged vehicle. If the vehicle need cross muddy land or slope, two pieces of guide rope or traction rod that can at least bear 1.5 times of machine weight will be used.
- g) The angle of the guide rope will be reduced to guarantee angle between the guide rope and center line of two vehicles is within  $30^\circ$ . Height of traction points of two vehicles shall be similar.
- h) Connection between dragged vehicle and the vehicle will be solid.
- i) Weight of the dragging vehicle or the machine cannot be lighter than the dragged loader and must have enough traction force and braking ability so that they can drag and brake two vehicles when going up or down the slope.
- j) When dragging the vehicle down from the slope, vehicle with enough traction force and braking ability will be used and another vehicle will be used to drag behind the dragged vehicle, which can guarantee dragged vehicle will not lose control and roll over.
- k) Beginning and stopping will be slow and the alarm flashlight will be turned on when dragging.
- l) When dragging the loader, the dragging speed cannot be more than 10km/h. the vehicle will be dragged to the closest repair plant as much as possible. If the

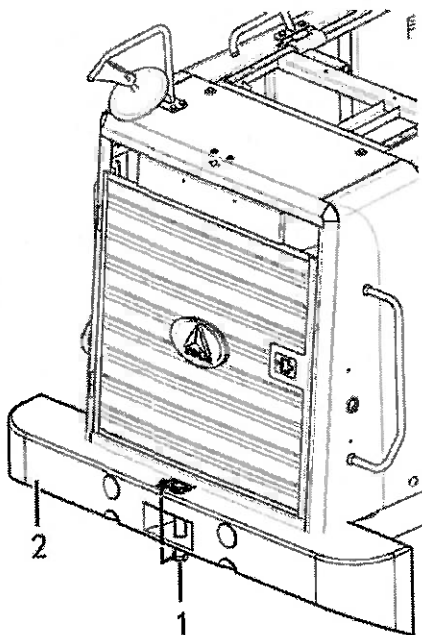

1 Traction pin

2 Balance weight

traction distance is more than 10km, or traction speed is more than 10km/h, front and rear transmission shafts must be dismantled or the loader must be placed on the trail for transportation.

Dismantle transmission shaft:

- ◇ The loader will be parked in flat place. Instructions for maintenance and repair will be abided by.
- ◇ All brakes will be loosened.
- ◇ Bolt of transmission shaft will be dismantled and transmission shaft will be removed from the drive shaft.



**Attention: after dismantling drive shaft, function of parking brake will lose effect; the engine cannot be started via traction; if there is provision about it in the country, operation will be conducted in accordance with these provisions.**

- m) After traction, before loosening traction rod and steel wire rope, the vehicle shall be parked on flat ground if possible and the wheel shall be blocked to prevent it from rolling. If the parking brake is loosened by means of mechanical method, it will be recovered.



**Attention: if you have not recovered parking brake before leaving the loader, you must leave a label on the steering wheel to explain —parking brake has lost effect.**

Operation in cold weather

Instructions in low temperature

If the temperature is too low, the engine will be difficultly started; the radiator may be frozen. Therefore, the following points shall be achieved:

- Fuel oil, hydraulic oil and lubricating oil with low viscosity will be used. Antifreeze will be filled. Specific oil is shown in the “P184 table of oil selection”.
- Instructions for using antifreeze:
  1. Antifreeze containing methanal, ethanol and propyl alcohol cannot be used.
  2. Any water seal agent cannot be use no matter it is used independently or used together with antifreeze.
  3. Different antifreezes cannot be mixed.

 **Attention**

**When filling antifreeze, you must keep far away from open fire.**

● Instructions for using the storage battery:

1. When surrounding temperature is decreased, the capacity of the storage battery will also be decreased. If the charging rate of the storage battery is low, electrolyte may be frozen. You shall maintain the charging rate close to 100% as much as possible and achieve thermal insulation. Therefore, the engine can be easily started in the following day.
2. If the storage battery is frozen, it cannot be charged or the engine cannot be started. The storage battery shall be dismantled and placed into greenhouse or warm water (don't allow water to enter into the storage battery). Temperature will be slowly increased to 15°C, otherwise, it may explode.
3. Storage battery that can be resistant to extreme coldness shall be used in extremely cold regions.

● Instructions after daily work has been completed

To prevent machine from frozen to affect vehicle operation of the following day, the following work will be conducted:

1. Sludge and water on the machine will be completely removed to prevent sludge, water or snow from entering into sealing place and being frozen and damaging sealing element.
2. The vehicle will be parked on dry hard ground. If it is not possible, the vehicle will be parked on wooden plate. Use of wooden plate can prevent vehicle from being frozen on the ground so that the vehicle can be driven in the following day.
3. The capacity of the storage battery under low temperature will be obviously decreased, the storage battery shall be covered or it shall be transferred to warm place and reassembled when working in the following day.
4. If the air temperature is less than 0°C, when antifreeze is not filled into cooling water, the bottom of the water tank and all water drain valves on the engine shall be opened to discharge all cooling water in the cooling system and evaporator of the air conditioning system to prevent machine and parts from frost crack. If it has been filled with antifreeze, it will be executed in accordance with instructions on the scutcheon of



antifreeze.

After cold weather is over

After it becomes warm, corresponding parts shall be changed to engine oil, fuel oil and hydraulic oil that are adapted to ambient temperature.



## Storage

### Before storage

If the loader need be stored for a long term, you need abide by the following steps:

1. If possible, the loader shall be parked on flat ground. If impossible, the wheel will be blocked to prevent it from rolling and the accessory device will be descended to the ground. In addition, all switches and all control handles will be checked to confirm they are at positions of "close" and in the middle. The parking brake switch will be pressed so that the vehicle is under parking brake state. All covers, windows and doors will be locked.
2. All parts of the vehicle will be cleaned and dried. Exposed components will be coated with anti-rust agent and the vehicle will be completely lubricated; surface that has not been painted (such as exposed part of lifting cylinder and piston rod of steering cylinder) will be coated with one layer of thin lubricating grease.
3. Tyre pressure will be checked to prevent tyre from strong sunshine.
4. Fuel tank and hydraulic oil tank will be filled to the largest mark.
5. Battery cathode will be dismantled and then covered or dismantled from the vehicle and then stored separately.

### Under storage

1. Daily storage
  - a) The bucket will keep horizontal grounded state to the ground via the vehicle. The vehicle will be stored in flat place. It will be stored in indoor dry place as much as possible. If it is stored outdoor, it need be covered with cloth.
  - b) The starting switch will be placed at the position of " |  
".
  - c) The control handle of the working device will be moved back and forth for two or three times. In addition, the handle will be kept for three seconds at its end to remove residual pressure of oil cylinder and flexible pipe. Then, control handle will be placed in the middle.
  - d) Transmission control lever will be placed at the neutral gear and parking brake switch will be pressed.



- e) The starting switch is placed at the “○” position and then the key will be removed for proper storage.
- f) Fixed lever will be used to connect the front frame and rear frame.
- g) All parts with lock shall be locked tightly and key will be removed for proper storage.

### 2. Long-term storage

The machine storage is divided into long-term storage and short-term storage. Short-term storage period cannot be more than two months and long-term storage period is over two months. Storage site of the loader shall be covered, ventilated and dry and shall not have corrosive and hazardous substances and gases. Before storing the loader, exposed part that is easily be corroded (such as piston rod and axle) shall be coated with anti-rust grease. Before long-term storage, the surface of the machine body shall be waxed for corrosion prevention.

- a) When the loader is not used for one month
  - In addition to instructions for “daily storage”, the following items will also be implemented:
  - The vehicle will be started for once per week and working device will be controlled at the same time for use at any time.
- b) When the loader is not used for over one month
  - In addition to instructions for “daily storage”, the following items will also be implemented:
  - Oil feeding place of all parts will be checked to confirm whether there are stipulated quantity of oil or not.
  - Considering storm runoff in the rainy season, the loader shall be parked on high hard pavement.
  - The storage battery will be dismantled.



**Attention: even if it is parked indoor, if it is hot or damp place, the storage battery shall also be stored in other dry places and charged for once in every month.**

- Cover will be covered in place with moisture (ventilating device, air filter).
- Tyre pressure is adjusted to standard pressure. Abrasion and damage of tyre will be checked.
- To remove load born by the tyre, it had better to be floated by lifting the vehicle. If it cannot be lifted, pressure must be checked for once in every week to maintain suitable pressure.

- Check will be implemented for once in every week so that the vehicle can be reset to the starting state. After starting the engine and conducting adequate heating operation, the vehicle will be moved forwards and backwards. Grease on the piston rod shall be cleared before operating the working device. After operation is completed, grease will be coated.

### After storage

When the loader completes long-term storage, the following operations will be conducted:

1. Covering for preventing damp will be removed.
2. Anti-rust grease that is coated on the exposed part will be cleared.
3. Crank case of the engine, transmission and drive axle will be cleaned and replaced with new oil after discharging oil.
4. Pollutant and water will be discharged from working oil tank and fuel tank.
5. Cylinder cover of the engine will be removed. Oil will be filled into valve and rockshaft. Working state of all valves will be checked.
6. Storage battery that has been dismantled will be reassembled and connected to cables.
7. Tyre pressure will be adjusted as per stipulated pressure.
8. Check prior to operation will be conducted.
9. Heating operation will be conducted.
10. All hinge joints will be filled with lubricating grease.



**Attention: if the loader has not been maintained and repaired as per month when being stored, you shall consult Shandong Lingong Construction Machinery Co., Ltd. or your distributor of Shandong Lingong.**

## Accessory device

### **Warning**

#### **Risk of fatal accident**

**Utilization of lifting or transportation accessory device may cause serious crushing injury or fatal accident such as death.**

**Accessory device cannot be used to lift or transport personnel.**

As for machine capacity, it is a decisive factor to use suitable accessory device for specific operation.

Abide by instructions in the operation and maintenance manual.

The machine owner will be responsible for accessory device that is installed on the machine. The machine owner will also be responsible for safety of the combination of the machine and accessory device.

Please contact distributor of Shandong Lingong to obtain duplicate of accessory device directory for more details about selecting accessory device.

Stability of the machine will be changed due to difference of accessory device and material density.

The machine has the function that working device or accessory device can be descended to the ground when the engine accidentally shuts down. When the engine shuts down, control lever of the working device will be slowly operated to descend the working device or accessory device to the ground



## Release pressure

Residual pressure in flexible pipes will cause huge difficulty to closure and trip of quick-change connector.

When disconnecting hydraulic flexible pipe, this problem can be overcome by releasing pressure of the hydraulic system.

1. Close the engine
2. Ignition switch is at the position of “ | ”.
3. Control levers with relevant functions will be moved forth and back and control levers will be kept at their ends for three seconds.

After pressure has been released, flexible pipe will become “loose”.

Accessory device must fall down to the ground when releasing pressure.

Residual pressure in hydraulic accessory device can be released by loosening locknut between flexible pipe and hydraulic oil pipe and then tightening. Meanwhile, attention will be paid to observation of accessory device.

Residual oil liquid will be collected.

### Signal Diagram

If view of operator is restricted, such as large volume load, signal personnel will be assigned.

If lifting, descending or moving is faster, moving action of signal personnel shall also be faster. If two or several operators use the same signal personnel, they need to confirm how to complete lifting and how to send signal to every operator in advance.

 <p><b>Start</b> Arm is stretched out horizontally and the palm points to the front.</p>	 <p><b>Stop</b> Right arm points up and palm points to the front.</p>	 <p><b>End</b> Both hands hold tightly at chest.</p>
 <p><b>Lift</b> Right arm points up and palm points to the front, hand marks a round slowly.</p>	 <p><b>Descend</b> Right arm points down and palm points to the front, hand marks a round slowly.</p>	 <p><b>Vertical distance</b> Both hands indicate corresponding distance.</p>
 <p><b>Move forward</b> Two arms are bent, palm points up, lower arm points to body slowly and moves upwards repeatedly</p>	 <p><b>Move backward</b> Two arms are bent, palm points down, lower arm leaves away from the body slowly and moves downwards repeatedly.</p>	 <p><b>Danger (emergency stop)</b> Two arms point up, palm points to the front,</p>



## Operation & Maintenance Manual for L968F Wheel Loader



Operating at the specific direction

The arm is stretched out horizontally, palm points down, and moves forth and back slowly towards the right.

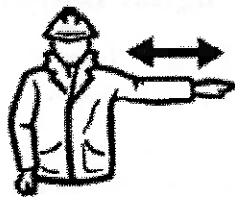

Operating at the specific direction

The arm is stretched out horizontally, palm points down, and moves forth and back slowly towards the left.



Horizontal distance

Both hands indicate corresponding distance.

# Repair and Maintenance



**Warning!**

**Burning danger!**

**Hot machine component may cause burning.**

**Before adjusting or repairing, the machine component will be cooled down and personal protective equipment will be worn.**

This part introduces some repair and maintenance operations that can be executed to machine operators. They have been summarized in “lubricating diagram and maintenance table” that has provided maintenance periods of relevant oils by means of graphic mode, which is shown in the P185.

Other work will be conducted by personnel through training or special equipment in the repair workshop. As for the work, you shall contact repair workshop authorized by Shandong Lingong.

## Repair position

Before you start maintenance work, the machine must be parked on the horizontal ground and make preparatory work as per the following figure.

After you complete maintenance operation, all fenders must be re-installed and all covers of the engine must be closed and locked.

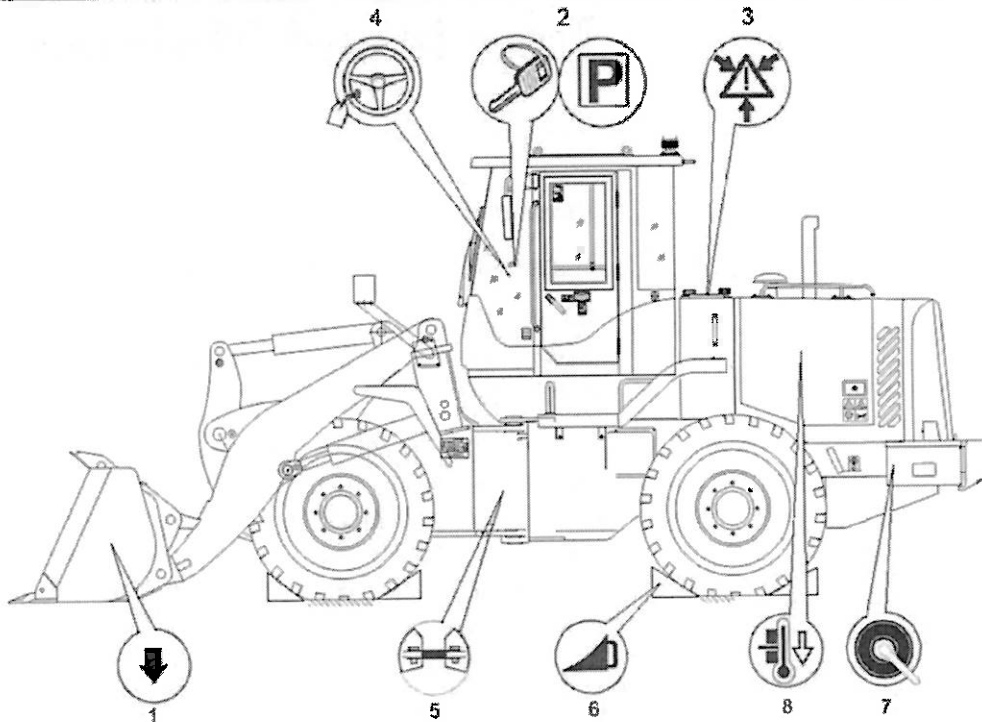

1. Accessory device is placed horizontally on the ground.
2. The engine is closed and ignition key is removed.
3. Decompression shall be conducted for pressure pipeline and oil tank to release high pressure to prevent accident.

### **Warning**

**If pressure is not reduced before opening the hydraulic system, hydraulic oil will be erupted under high pressure and may cause serious personal injury accident.**

4. Yellow-black warning banner shall be connected to the steering wheel (red warning banner can be used in USA).
5. Frame locking rod has been connected.
6. Vehicle is under parking brake state and vehicle will be pegged.
7. Master power switch will be closed.
8. The machine will be cooled down.

### **Warning**

**If you must operate before the machine has been cooled down, you must be very careful about hot liquid and machine part to avoid burning.**



## Maintenance guide

You shall carefully read the following contents before repair and maintenance of the vehicle:

### Instructions before repair:

- Repair shall be conducted on solid and flat pavement.
- Working device is close to the ground and bucket will be placed horizontally.
- All control levers must be placed in the middle.
- Control handle of manual brake valve will be drawn up or parking brake switch will be pressed to implement braking.
- Stop dog shall be placed in the front and rear of the tyre.
- Frame locking rod will be used to lock front and rear frames.

### Clean machine

Traditional automobile maintenance product shall be used to regularly clean the machine to remove damaged paint surface and potential hazard of other machine surfaces.

#### Reminder

Powerful cleaning agent or chemical agent cannot be used to minimize danger for damaging the painting surface.

### Attention!

**Parts with dust, fragment or similar matters on the machine shall be cleaned in every day to remove fire disaster risk, which is shown in the P113.**

Suggestions for cleaning the machine:

- The machine is parked in place that is specially for cleaning.
- Abide by instructions provided in the vehicle maintenance product.
- Water temperature cannot be more than 60°C(140 °F) .
- If using high pressure cleaning device, spray nozzle must be at least 20 to 30cm (8in to 12 in) away from the machine. If pressure is too high or distance is too close, the machine may be damaged. Suitable method will be adopted to protect electric wire.

### Reminder

If you use high pressure cleaning device, you need be careful to guarantee that the label is not loose.

- Soft sponge will be used.
- At last, the machine will be flushed with water.
- After cleaning, the machine will be lubricated.
- If necessary, the painting surface will be repaired.
- If the label is broken or is difficult to identify, it must be immediately replaced. You can obtain more information from the P3 to P21.

### Maintenance of painting surface

Machine that is used under corrosive conditions is easier corroded. As preventive measure, the painting surface shall be maintained for once every six months. If utilization condition cannot be confirmed whether it is corrosive or not, you can contact the distributor.

- The machine will be cleared at first.
- One layer of Dinol 77B whose thickness is 70-80  $\mu$  (or equivalent anti-rust agent of transparent wax) will be coated.
- One Dinol 447 (or equivalent) protective layer shall be coated at parts that may be abraded under the fender.

### Repair coating layer

- The machine will be cleared at first.
- The painting surface will be checked to confirm whether it is damaged or not.
- Any damaged painting surface will be repaired in professional way.

### Engine

#### Check of engine oil level

Oil level will be checked for once every ten hours.



#### Attention

**Oil quantity must be checked before operation or 15 minutes after the engine is closed.**

- The loader will be parked in flat place, transmission control lever is at the neutral position, the parking brake switch will be pressed and stop dog will be placed in the front and rear of the tyre.

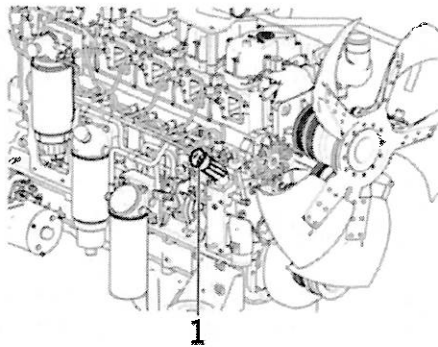

1 Engine oil inlet

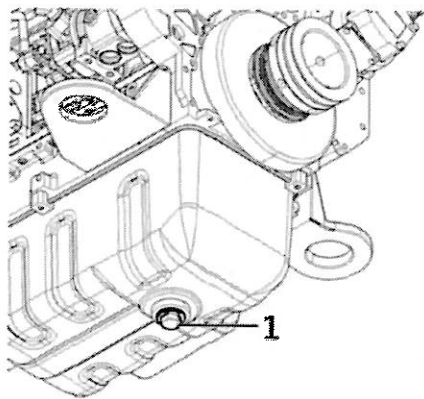

1 Drain plug

- Side door of the engine hood on the right side of the engine hood will be opened.
- Oil gauge will be removed and inserted after cleaning and then removed for check (at least twice).
- Oil level shall be between marks on the oil gauge.
- Oil gauge will be placed at original position, side door of the engine hood will be closed. Engine oil will be selected in accordance with "P157 table of oil selection".

### Replacement of engine oil

Engine oil will be replaced for once every 250 hours (first time: 100 hours).

- The loader will be parked in flat place, transmission control lever is at the neutral position, the parking brake switch will be pressed and stop dog will be placed in the front and rear of the tyre, the engine will be started for idling operation, after the oil temperature is between 20°C and 40°C, the engine will shut down.
- Purge cock in the bottom of the engine will be loosened and oil will be discharged and placed in the vessel.
- Old oil will be discharged completely, purge cock will be tightened, right side door of the engine will be opened, engine oil will be injected from the engine oil filler, the engine will be operated under idling state. Purvey cock and engine oil filter will be checked to confirm whether oil leakage is existed or not.
- After the engine has been shut down for about 15 minutes, engine oil will adequately return to the oil pan and oil level of engine oil will be checked again.

### Replacement of engine oil filter

#### Warning

#### **Burning danger**

**Hot engine oil may cause serious burning to exposed skin.**

**When disposing hot engine oil, you must wear personal protective glove, safety glasses and protective clothes.**

 **Warning**

**Burning danger**

**Boiling liquid and machine parts will cause burning. Overhauling can be conducted after the machine has been cooled down.**

 **Attention**

- **After replacing filter element, the engine must be operated for at least one minute under idling state to guarantee engine has been lubricated before working.**
- **Excessive mechanical screwing may damage thread or damage seal of engine oil filter.**

When replacing engine oil, engine oil filter element will also be replaced.

**Dismantling**

- Area surrounding the mounting base of engine oil filter will be cleared and filter will be dismantled by using filter element wrench.

**Installation**

- Filter element is filled with diesel and rubber seal ring is coated with engine oil.
- After seal ring contacts the foundation bed, it will be tightened for 3/4 to 1 circle.
- The engine is started and seal ring is checked to confirm it has been sealed. If not, the filter element will be dismantled for checking the seal face.

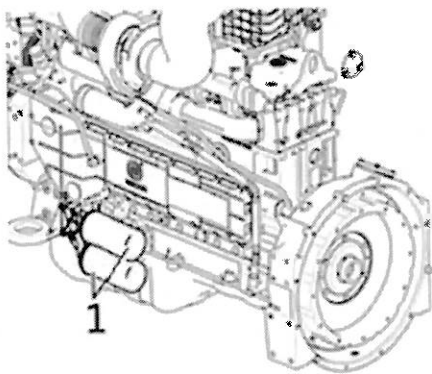

1 Engine oil filter

## Fuel system

### Filling of fuel

Clean fuel is very important for guaranteeing non-fault operation of the diesel engine.

- Surrounding area will be carefully cleaned before dismantling the filler cover.
- Fuel cannot leak when filling. Top of the fuel tank will be kept clean. Saw dust immersed into diesel and dirt and dust on oil tank will constitute serious potential hazard of fire disaster!
- Fuel tank will be kept at filled state to prevent water in fuel tank from coagulation in cold season.

#### Attention!

**The machine is equipped with electric control engine. Requirement for oil is strict. You shall fill diesel complying with GB252-2015 standard, otherwise, it will cause fuel system fault.**

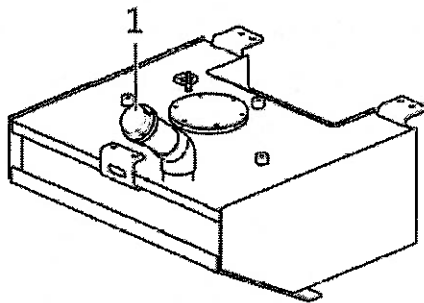

1 Filler cover

### Discharge of fuel tank

Sediment will be discharged for once every 100 hours.

If low-quality fuel is used to operate the machine, the fuel tank will be more frequently discharged.

1. Suitable vessel will be placed below the discharge outlet.
2. Open discharge plug.
3. All sediments will be discharged.

**Important! Filter/liquid will be disposed by means of environment-friendly and safe way.**

4. Install discharge plug.
5. Close filler cover.

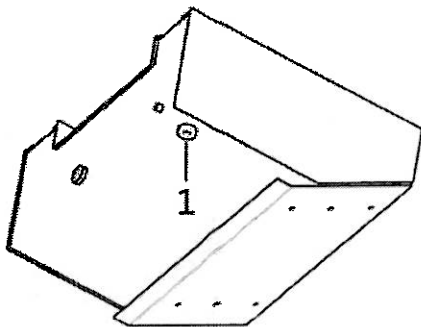

1 Oil discharge plug

## Replacement of fuel filter, main and grade-II filters

Fuel filter will be replaced for once every 500 hours.

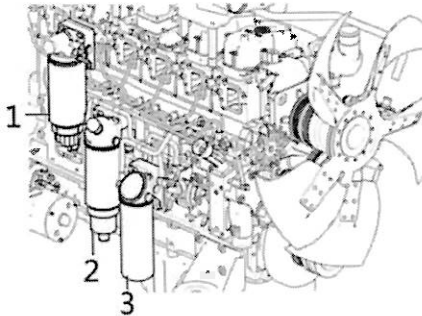

- 1 Primary fuel filter
- 2 Grade-II fuel filter
- 3 Grade-II fuel filter

1. The vessel will be placed below the filter.
2. Primary fuel filter will be dismantled. Filter will be dismantled by using engine oil filter wrench.
3. Packing cup will be loosened.
4. Grade-II filter will be dismantled.
5. Sealing element of new filter will be coated with new engine oil. Filter will be tightened in accordance with instructions on the filter.
6. After replacing filter, fuel system must be deflated in accordance with P155.

### Attention!

Old filter will be disposed by using environment-friendly way.

### Deflation of fuel system

1. The machine is at the maintenance position, which is shown in P147.
2. Rotate hand pump anticlockwise, so as to make it stop at pumping position. Pump for about 200~300 strokes, until you start to feel that there is resistance in the hand pump. Then pump for about 20 strokes. Push the hand pump and rotate it clockwise to lock it.

Attention!

Starting motor cannot be used for deflation.

3. Power is opened; engine is started and operated for several minutes under idling state. If the engine is difficultly started, hand pump will be used to deflate.

### Attention!

Hand pump cannot be used when the engine is under operation.

Filter and fuel will be disposed by using environment-friendly way, which is shown in the P77.

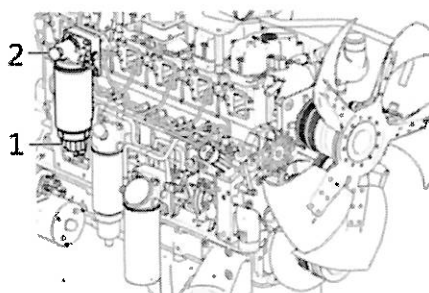

- 1 Dehydrator
- 2 Hand pump in the top of the filter

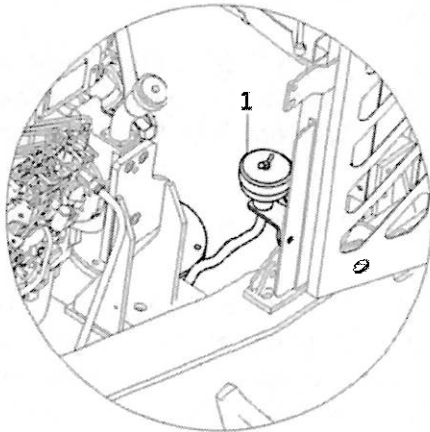

1 filter of fuel tank ventilation device

## Replacement of the filter of fuel tank ventilation device (L956F)

The filter of fuel tank ventilation device is replaced every 2000 hours.

The filter, oil and working fluid are disposed in an environmentally friendly way. Please refer to page 75.

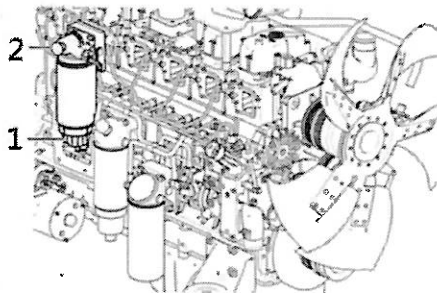

1 Dehydrator

2 Hand pump in the top of

## Oil-water separator

When display screen shows information, the dehydrator will be discharged.

Water in fuel must be manually discharged.

One-way valve in the head of the filter is used to prevent fuel from returning to oil tank. As fuel cannot return, pressure is maintained. Unless new fuel is pumped, water in fuel will not be discharged.

1. One end of flexible pipe is inserted into vessel.
2. Drain pipe is loosened until fuel flows out of flexible pipe and is pumped to remove water. Bubble in the dehydrator can be gradually seen.
3. Discharge pipe outlet will be tightened after discharging water.

Filter and fuel will be disposed by using environment-friendly way, which is shown in the P77.

### Attention!

**Oil-water separator will be checked and water will be timely discharged in every shift, otherwise, fuel system will break down.**

## Air filter of engine

Attrition rate of the engine greatly lies in cleanliness of absorbed air. Air filter can prevent dust or other impurities from entering the engine. Therefore, regular check and correct maintenance of air filter are very important.

Main filter element of air filter of the engine, cleaning and replacement

Main filter element and safety filter element shall be replaced or cleaned every 500 hours or when engine air filter blockage warning signal appears on the instrument panel. Working time between two adjacent replacements of filter is different due to difference of working conditions. Filter element need be more frequently replaced under special environment.

Filter element can be replaced in accordance with instructions of the repair workshop authorized by Shandong Lingong. However, filter element must be replaced after it has been cleaned for five times or if the filter element is damaged.

### Mechanical cleaning

1. Pull the snap ring 2 and open the cover 1.
2. Press the main filter element 4 with two thumbs and pull it out at the same time. It is to prevent pulling the safety filter element together with the main filter element.
3. End of the air filter element is carefully beaten by aiming to a soft and clean surface.
4. Air filter element and cover will be re-installed.

### Attention! Don't knock hard surface.

### Clean with compressed air

1. Clean and dry compressed air will be used. Maximum pressure is 500 kPa (5 bar) (73 psi). The distance from spray nozzle to the filter element face will be at least 3 to 5 cm (1-2 in).
2. Filter will be blown along the folding part of the interior.
3. Filter will be checked by using a lamp.
4. The filter must be scraped and discarded if there is minimum hole, crack, scratch or other damages.
5. Air filter element and cover will be installed.

**Attention! Damage need be easily discovered. This check can be conducted in dark room.**

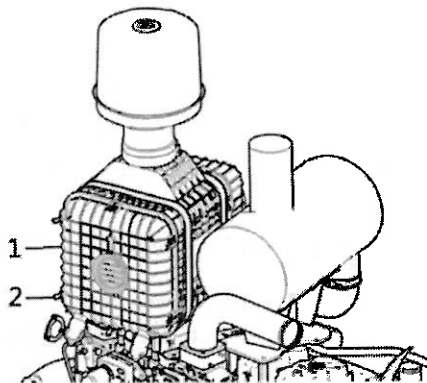

1 Air filter  
2 Snap ring



### Safety filter element of air filter of the engine, replacement

**Attention!** The safety filter element cannot be cleaned, and can only be replaced.

**Attention!** The safety filter element can be dismantled only at the time of replacement.

If the main filter element is damaged, the safety filter element shall work as protective filter.

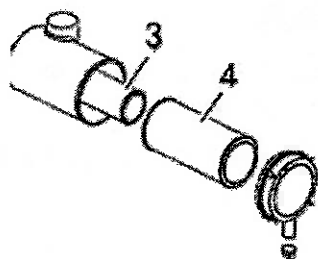

3 Safety filter element  
4 Main filter element

1. The safety filter element shall be dismantled carefully and accurately, so as to prevent impurities from entering the engine.
2. Carefully check whether the new safety filter element is installed correctly.

### Cover of air filter, cleaning

When cleaning air filter element, the cover of the air filter shall be cleaned.

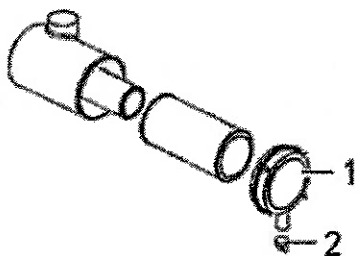

1 Cover  
2 Vacuum valve

1. Cover (1) and valve (2) will be removed from the air filter.
2. Cover and valve will be cleaned.
3. They will be installed on the air filter again.

## Cooling system

### Liquid level of coolant, check

Liquid level of coolant will be checked every 10 hours or when the display screen displays information

The liquid level shall be between the marks of "FULL" and "LOW" on the expansion tank.

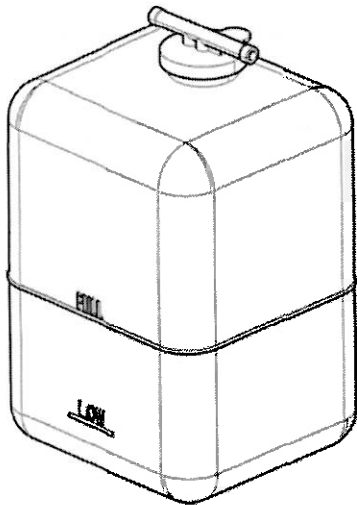

### Replacement of coolant

Coolant will be replaced for once every 2000 hours or one year, which will be subject to the earlier one.

#### Warning

**Skin without protection has risks of serious burning and scald.**

**High pressure hot coolant will rush out of the water tank and cause serious burning. Before dismantling cover of the expansion tank:**

- The engine is closed.
- Engine is cooled.
- Pressure cap will be slowly rotated to release pressure.

#### Attention

**Machine damage danger.**

**Utilization of coolant that exceeds the stipulated interval will block the cooling system and damage the engine. Coolant will be replaced as per stipulated interval.**

Discharge

1. The engine will be closed for cooling.
2. The cover of the water tank of the radiator will be dismantled.
3. The discharge point of coolant is located in the lower left corner of the radiator.
4. Flexible pipe is placed into suitable vessel.
5. Drain valve 1 will be opened.
6. The discharge point will be recovered.

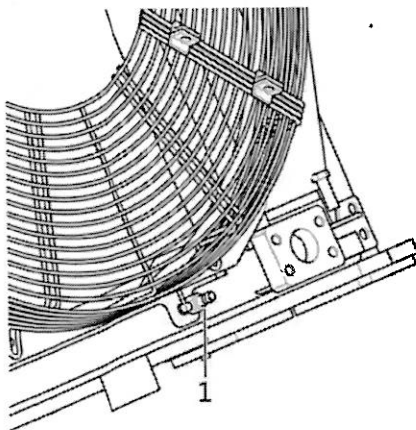

1 Drain valve of coolant

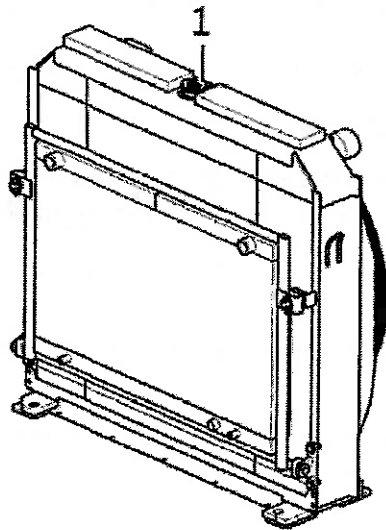

1 Filler of coolant

#### Filling

Coolant will be filled via the cover of the water tank of the radiator.

1. Coolant is filled into water tank of the radiator.

#### Attention

Cooling system will operate under high pressure. You must guarantee that seal ring is not damaged and is reliable and fixed.

2. The engine will be kept operating until the engine is heated and all air in the system has been exhausted.
3. The engine will be heated and then cooled. Liquid level will be checked.

#### Attention

Coolant cannot be filled when the engine is still hot, which will cause crack to engine body and air cylinder cover.

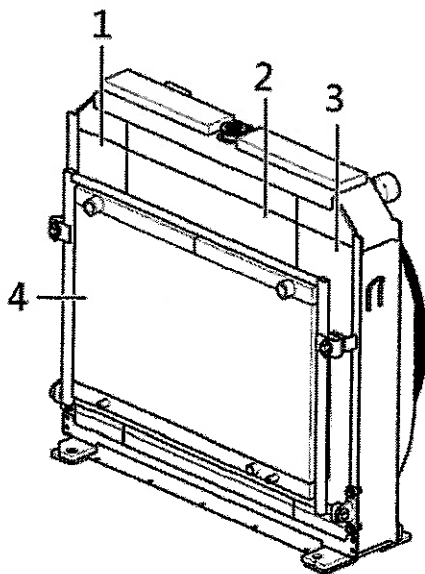

1 Hydraulic oil radiator  
2 Water radiator  
3 Air cooler  
4 Transmission oil radiator

#### Radiator, cleaning

The radiator shall be regularly cleaned to guarantee cooling effect of the engine. Radiator will be checked in every day when operating under conditions with lots of dust.

#### Attention

The radiator shall be cleaned when the engine is closed.

#### Attention

Careless operation will easily damage filter of the radiator.

1. Engine hood will be opened.
2. Compressed air will be used to blow the radiator.
3. The interior of the radiator will be checked and cleaned.
4. Engine hood will be closed.

Fan belt, check

Tensity of fan belt will be checked for once every 50 hours.

 **Warning**

**Danger of serious personal injury**

**Rotating components may cause serious crushing or cut. The engine will be closed before checking tensity of the belt.**

Check and adjust belt tensity

1. Driving belt of Air condition compressor; tensity and condition will be checked.
2. Driving belt of AC generator, coolant pump, fuel pump and fan; condition will be checked; tensity roller will be checked to confirm whether it has been worn out or not.

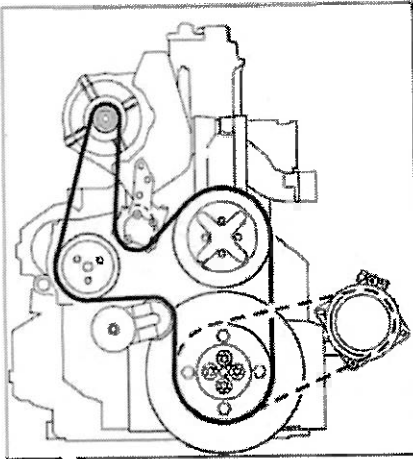

## Electrical system

Driving light and control light shall be checked in every day.

### Storage battery

Storage battery includes two 12V storage batteries in series to provide 24V voltage for the system.

Master power switch

Master power switch is in the battery compartment, which is connected to the storage battery. If the machine need be idled for certain period, the master power switch shall be closed.

### Storage battery, maintenance

The storage battery is free from maintenance.

Cable joint and terminal of the storage battery will be checked every 250 hours. Cable joint and terminal of the storage battery must be good and clean. Exterior of them will be coated with lubricating grease, for example: Vaseline will be coated as anti-corrosive agent.

### Storage battery, charging



#### Warning

**Danger of serious personal injury**

**Short-circuit, open fire or spark near the rechargeable battery may cause explosion.**

**Charging current will be cut off before disconnecting connection of charging cable clamp. It is strictly prohibited to charge the storage battery near open fire or spark. Storage battery will be charged in areas with adequate ventilation.**



#### Warning

**Danger of chemical burning!**

**Electrolyte of the storage battery contains corrosive sulfuric acid, which may cause serious chemical burning. If electrolyte splashes to exposed skin, you need immediately remove it and use soap or lots of clean water to flush injured parts. If electrolyte splashes into eyes or other important parts, they need be cleaned with lots of clean water and obtain medical treatment at once.**

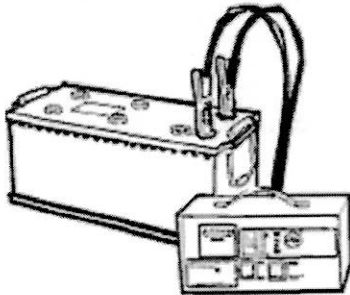

1. Charger will be connected.

**⚠ Attention**

**Charging voltage must be the same to voltage of the storage battery.**

2. Two storage batteries will be charged to equal electric quantity.
3. The charger will be disconnected before starting.

**Welding**

**⚠ Attention**

**Welding operation related to the machine can only be conducted by qualified welders.**

**⚠ Attention**

**It is strictly prohibited to weld when the electrical system is electrified. If welding is necessary, the cathode of the storage battery must be cut off and plug connectors on all ECU must be removed, otherwise, the controller of the complete machine will be damaged.**

The following operations shall be executed before electric welding is conducted for the machine or accessory device connected to the machine:

1. Master power switch will be closed.
2. The storage battery will be disconnected, cathode amphenol connector will be disconnected at first and then the positive amphenol connector will be disconnected.
3. Electronic unit will be removed. You can contact repair workshop authorized by SDLG for more information.
4. Ground joint of welding equipment will be connected and it need be as close as to the welding point. Current will not go through the bearing.

**Relay and fuse**

The relay and fuse are located in the fuse box on left-rear side of the operator's seat. Identification is attached to the external side of the fuse box, which has provided power utilization equipment that is connected to all relays and fuses.

Fuse whose current is higher than the rated current specified in the identification cannot be installed (otherwise, circuit board may be damaged or ignited).

If one of relays breaks down, another relay whose function is not so important can be used to replace the relay with fault to temporarily remove fault.

You can refer to the P116 for more information about relay and fuse.

### **Bulb, replacement**

Bulb replacement and other operations for working light shall be conducted by the repair workshop authorized by Shandong Lingong.



### **Attention**

**As bulb contains mercury, after the bulb has been replaced, it shall be disposed in accordance with local laws and regulations for dangerous waste.**

## Transmission box

### Oil level checking

Check the oil level every 50 working hours.

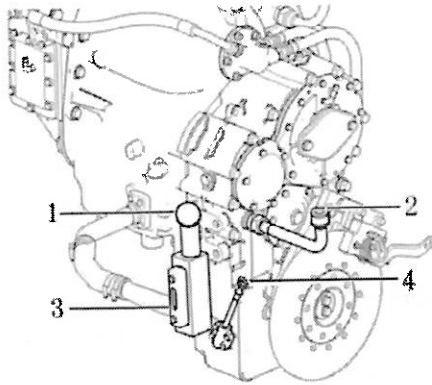

- 1 Transmission refueling port
- 2 Transfer box filler
- 3 Gearbox oil level gauge
- 4 Transfer gear oil gauge

1. Park the machine on level ground and put the transmission control handle in the neutral "N" position. Pull the brake valve manual control handle or press the parking brake switch to carry out braking. Block the front and back of the tire.
2. The temperature of transmission box is in the operating temperature range.
3. Start engine and let the engine run in the idle status about 700rpm for 2-3 minutes.
4. Insert the oil dipstick inside oil pipe and tighten it. Then take it out to read the oil level (do this at least twice).
5. Transmission box
 

When the oil temperature is between 50°C~60°C, oil level should be between bottom scale and middle scale.

When the oil temperature is between 70°C~90°C, oil level should be between highest scale and middle scale.
6. Transfer case
 

When the temperature is above 50°C, the oil level should be between the lower and upper graduation line of vernier.
7. If the oil level is not between defined ranges, please fill defined hydraulic transmission oil. The choice of the hydraulic transmission oil can be found in page 174.



 **WARNING**

- When the engine stops rotating, the transmission oil level basically will rise, increased much with a gearbox installation conditions. The transfer gear oil and engine whether in idle has nothing to do, but the oil must be hot!
- The cold car level check is to ensure that transmission, torque converter has adequate circulation flow, decide the level at the end of the standard is to meet the requirement of the hot oil.

**NEW OIL REPLACEMENT**

Change the oil every 1000 working hours (100 working hours for the initial replacement).

 **WARNING**

The temperature of transmission oil may be high, so wear protective clothing, and operate it carefully to prevent injury.

 **WARNING**

- **Put the oil when attention should not be carried out under cold state, the oil temperature at about 40 °C when the oil discharge effect is the best. When you put the oil, not only to the transmission of the oil in the tank clean, but also to the radiator and oil pipe within the clean.**
- **Before transmission, according to the provisions of the oil by adding proper amount of oil, and should be considered the first refueling, coolers, filters, tubing and oil filled volume of the converter. The amount of fuel to in the future than conventional gas amount to.**
- **If it is found that the old oil is dirty, should not be directly refueling, but also should take out the side of the rough filter, cleaning the parts. If there is a large amount of metal powder or debris, please contact the maintenance personnel.**
- **In order to install the demolition of the various parts, adding a small amount of hydraulic transmission oil, start the engine, idle running for 3 to 5 minutes, to release the oil in the bottom of the oil, to rejoin the provisions of oil.**

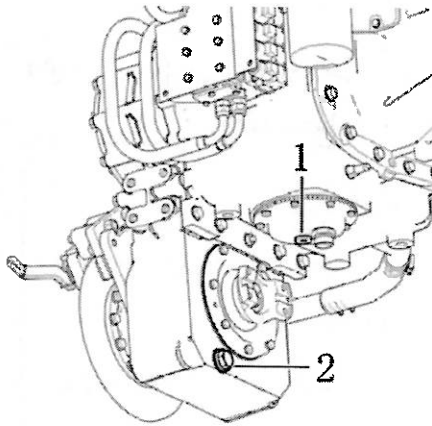

1 gearbox oil drain plug  
2 transfer gear oil drain

1. Park the machine on level ground, place in the service position, and put the transmission control handle in the neutral position. Pull the brake valve manual control handle or press the parking brake switch to carry out braking. Block the front and back of the tire.
2. Transmission box should be at working temperature. Loosen the oil drain plug on the side of the transmission box and transfer gear to drain the oil, and contain it with container.
3. Drain all the oil out and clean the oil on the drain plug, the transmission box and the transfer gear. Install a seal on the oil drain plug when screwing it back in.
4. Open the oil filler cover of transmission box and the transfer gear on the left of loader. Fill the defined hydraulic transmission oil, and then fasten the cover of the oil filler.
5. Start the engine and run it at idle. Fill the oil until the oil level gets between bottom scale and middle scale.
6. All the gears should be selected once.
7. Check the oil level. If the oil is low, fill it again.
8. Close filler cap.

## REPLACEMENT OF TRANSMISSION OIL FILTER

Change the oil filter every 1000 working hours (100 working hours for the initial replacement).

### WARNING

- Transmission oil filter must be changed at the same time to replace the transmission oil.
- Daily work should pay attention to the filter bypass safety valve is open, such as the long-term opening of the safety valve will make the filter loss.
- The filter is an important guarantee to ensure the cleanliness of the transmission oil. The normal operation of the transmission control valve is closely related to the cleaning of the lubricating oil.
- Attention should be paid to the installation, transportation and storage of the filter! Damaged filter must not be used.
- When installing the filter, should avoid its external stress, and pay attention to not too tight.

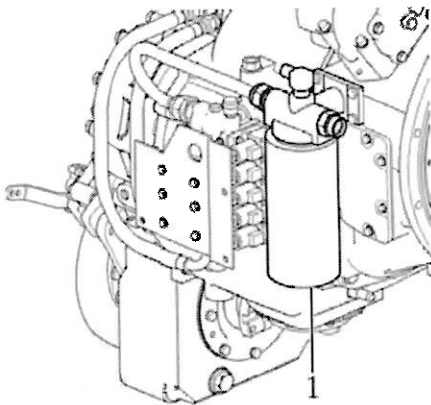

1 Transmission oil filter

1. Put a clean vessel under the filter, and use a wrench to remove the filter.
2. Install new filter and tighten it according to the instructions on the filter.

Deal the filter in an environmentally friendly way.



## **CLEAN THE OIL ABSORPTION FILTER SCREEN OF TRANSMISSION BOX**

**Clean the oil filter screen every 1000 working hours.**

The oil absorption filter screen is located in the bottom of transmission box.

1. Remove the cover and oil absorption filter screen, and clean the internal parts. Check and ensure the parts are not damaged.
2. Install a new gasket between cover and transmission box
3. Reassemble the absorption screen.

## Drive axle

### OIL LEVEL CHECKING

Since it is hard to set both the oil drain plugs of front drive axle and rear drive axle to horizontal position at the same time, you have to take two times to check the oil level.

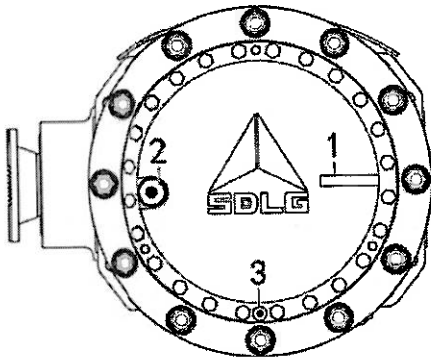

1 Line

2 Round border oil plug

3 The wheel oil drain plug

1. Drive the machine to level ground and move at low speed. Make the drive axle of the wheel side surface of groove in a horizontal position, round border oil drain plug at this time should be in the groove downwards, and the wheel side put oil screw is in below, as shown in the figure. Set transmission control handle to neutral. Pull the brake valve manual control handle or press the parking brake switch to carry out braking. Block the front and back of the tires.
2. Clean the wheel side oil drain plugs and the oil check plug on middle of axle shell. Remove the plugs and check, the oil level should get to the lower edge of each plug hole. Add specified gear oil if necessary. For selections of gear oil, please refer to page 174.
3. Check the oil level of the other axle in the same way.

## GEAR OIL REPLACEMENT

Change the gear oil every 1000 working hours (100 working hours for the initial replacement).

### ATTENTION

When checking, maintaining, testing or adjusting the machine, be sure to collect the liquid that produced by disconnecting any oil pipes or disassembling any components that contains liquid with clean vessel. Oil discharging should be done after driving the machine for a period of time so that the sediment in the axle can be mixed in the oil thoroughly.

### WARNING

The temperature of gear oil may be high, so wear protective clothing, and operate it carefully to prevent injury.

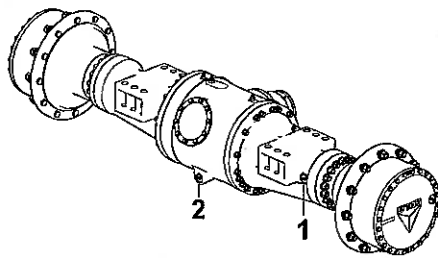

1 Oil filling point on axle shell  
2 Oil drain point on axle shell

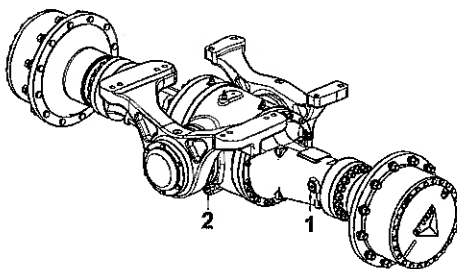

1 Rear axle housing fill plug  
2 Rear axle housing drain plug

1. Park the machine on level ground and run in idle status for about 10 minutes. Press on the accelerator gently to move the machine slowly to let the oil drain plug on the wheel side of the front axle go to the lowest position.
2. Stop the engine. Set transmission control handle to the neutral position. Pull the brake valve manual control handle or press the parking brake switch to carry out braking. Block the front and rear wheels.
3. Loosen the oil drain plugs on the two wheels on the end sides of the front axle and the oil drain plugs at the center bottom of the axle shell to drain oil to the container.
4. Drain out all the old oil and tighten the oil drain plugs at the center bottom of the axle shell and wheel side.
5. Unscrew the front drive axle wheel bridge shell gas plug.
6. Add new gear oil from the oil drain port at the end of two wheels sides of the front axle and the oil filler at the middle of the axle shell. Then check the oil level again.



7. Tighten the oil drain plugs at the end of two wheels sides of the front axle and the oil filling plug in the middle of the axle shell.
8. Replace the rear axle gear oil according to the procedures above.

### **LUBRICATION OF TRANSMISSION SHAFTS AND SUPPORT BEARINGS**

Apply grease to the transmission shafts and support bearings every 10 working hours. See page 170.



## **Braking system**

Service braking system is air over hydraulic disc type brake. Parking brake system is power-driven gas-control disc type

### **Brake disc of service braking, check**

Thickness of brake disc and residual situation of brake pad will be checked. If brake pad has been completely worn out, it must be replaced by repair workshop authorized by Shandong Lingong.

### **Parking brake and check**

#### **Warning**

**Crushing danger!**

**Accidental moving of the machine will cause serious injury.**

**If some personnel are in dangerous area, parking brake test cannot be conducted.**

## Wheel

### Tyre and check pressure

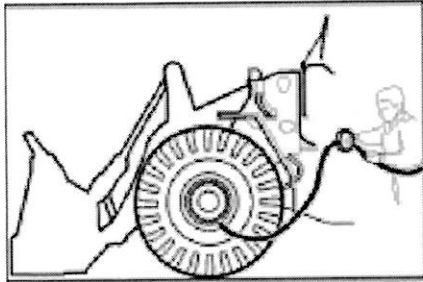

### Warning

#### Explosion danger

**Tyre may be exploded when inflating to tyre. Tyre explosion may cause fatal injury. Self-locking type pneumatic chuck with long enough flexible pipe is used to inflate tyre so that personnel need not stand in front of the rim and can keep far away from it. During the inflation period, no one stands in the front of rim or passes through the rim.**

Recommended pressure shall be usually used, which is shown in P187. Pressure may be regulated under special ground conditions, which will comply with instructions of tyre manufacturer and cannot exceed maximum allowable pressure.

Before delivery, tyre pressure may have been increased. Therefore, tyre pressure will be checked and regulated according to suggestions before the machine is used for the first time.

### Warning

#### Explosion danger.

**Rim may be damaged or tyre may be exploded if trying to repair or weld rim equipped with inflated tyre. Tyre explosion may cause fatal injury.**

Repair work of tyre and rim must be conducted by repair technicians through training.

Pneumatic tyre that is applicable to pressure rising will be described in the below. If tyre has lost all pressure, a repair technician through training shall be assigned.

1. When checking pressure, tyre shall be under cold state and the machine shall not have load.
2. All other personnel will leave dangerous area (front of the rim).
3. Stand near the tyre face. Tyre installed on open type rim may explode and cause injury or cause death under the worst situation.
4. One piece of long flexible pipe will be used so that you can stand outside of dangerous area (with self-locking pneumatic chuck).
5. Tyre on the stock wheel (standby wheel) shall be stored horizontally and shall be inflated enough so that rim component will be kept under suitable position.



6. If the machine has been operated when the tyre pressure is lower than the 80% of recommended tyre pressure mentioned in the specification, or tyre or / and rim has obvious damage or is suspicious of damage, tyre cannot be inflated again.

### **Wheel bolt and checking and tightening**

If the tyre has been replaced or dismantled due to other reasons and wheel has been re-installed, tightness of wheel bolt must be checked after working for ten hours.



## **Front window wiper system**

### **Cleaning liquid storage pot**

Liquid storage pot of the cleanser is on the left front side of the cab.

1. When there is risk of freezing, cleaning solution shall have enough antifreeze.
2. It will be filled if necessary.

## Air conditioning (option)

### Attention

If the loader needs to operate under high temperature environment, the users are advised to optionally install air conditioning system.

Filter element of air conditioning shall be replaced once every 500 hours.

In case of poor environment, pat with hand or clean the filter element with dried compressed air. If still apparently feeling that the blowing rate is insufficient, replace it in advance.

Let a repair shop authorized by SDLG check the air conditioning once every year. Handling rules of refrigerant is shown in P71.

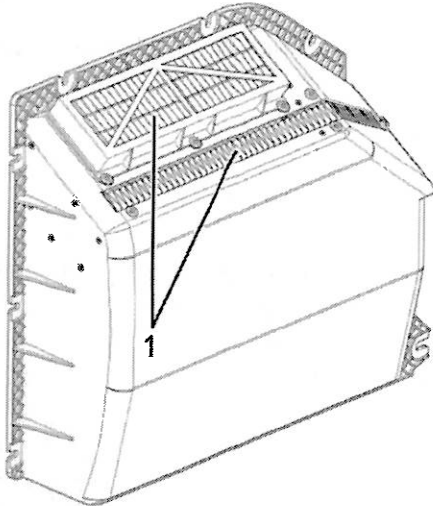

1 Filter element of air conditioning

## Driving belt, check

### Warning

**Danger of serious personal injury**

Rotating components may cause serious crushing or cut. The engine will be closed before checking tensivity of the belt.

Regularly check tension and wear of the driving belt.

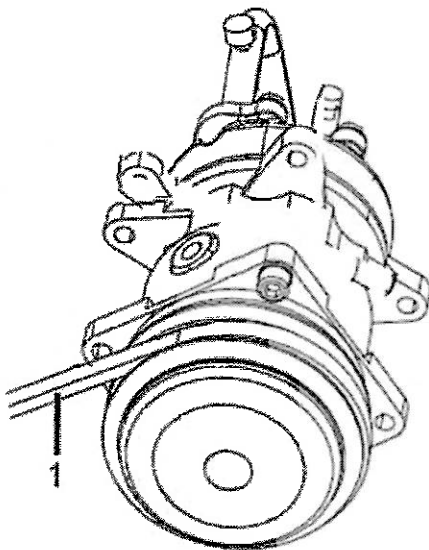

1 Driving belt of air condition compressor

## Condenser, clean

### Attention

**Do not wash it at high pressure.**

The condenser shall be cleaned regularly according to the following steps:

1. Open the condenser cap.
2. Use the compressed air to blow the condenser clean from below.
3. Close the condenser cap.

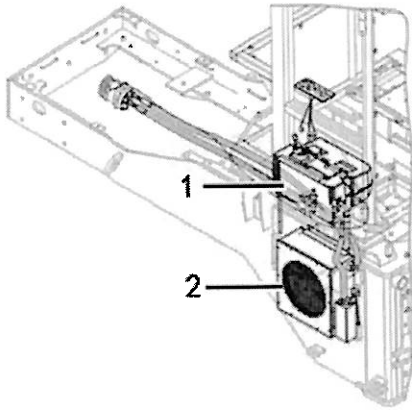

1 Evaporator  
2 Condenser

### Attention

**If the system pressure becomes too high due to blockage of the condenser, the air conditioning will be cut off. Before the system is restarted with switch, the condenser must be cleaned firstly.**

## Evaporator, clean

### Attention

**Do not wash it at high pressure.**

The evaporator shall be cleaned regularly. Simple cleaning can be conducted if the evaporator remains in the state of installation. Use soft brush, and do not use compressed air.

Evaporator cap and filter element of air conditioning shall be dismantled first before cleaning, and then shall be reinstalled.

In case of more thorough cleaning, the evaporator must be loosened from its mounting seat, and cleaned from behind. So this work shall be carried out in a repair shop authorized by Shandong Lingong.

## Hydraulic system

Working hydraulic system and steering system use the same hydraulic oil tank.

Absolute cleanliness is required for any operation of the system. Even if extremely small particle may also damage or block the system. Therefore, relevant areas shall be cleaned before executing any work.

Pressure limiting valve of the hydraulic system has been set correct value before delivery. If other personnel who don't belong to repair workshop authorized by SDLG has changed setting of the valve, the warranty provided by the manufacturer will become invalid.

### Hydraulic oil level and check

Oil level will be checked for once every 50 hours.

- a) The loader will be parked on flat site, bucket is horizontally placed on the ground, front and rear frames don't have included angle.
- b) Check the oil level indicator of the hydraulic oil box on the left side of the machine. The oil level is normal if the level indicator scale is at a range of  $\pm 2$  of middle scale. If the oil level indicator is lower than scale 10 of the middle scale, please add hydraulic oil. Selection of hydraulic oil is shown in "P187 table of oil selection", similarly below.

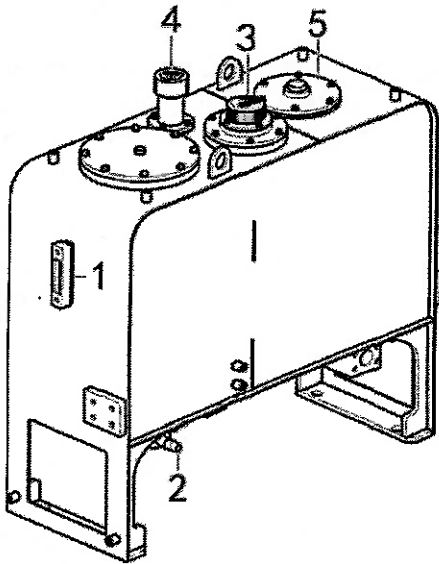

1. Oil level pointer
2. Oil drain (ball valve)
3. Oil filler filter element
4. Vent (air) filter
5. Return oil filter element

### Hydraulic oil and replacement

#### Warning

**In the oil replacement process, various operations of the machine shall be conducted in accordance with relevant safety**

#### Attention

**Special attentions shall be paid to cleanliness of hydraulic oil and foreign matter cannot enter into hydraulic system in the oil replacement process.**

#### Warning

**Hydraulic oil may be under high temperature, protective articles will be worn and careful operation is required to avoid personal injury.**



1. Sundries in the bucket will be cleared. Loader will be parked on flat site. Gear control lever is at the neutral position, parking brake switch will be pressed, and the engine will be started for idling operation for ten minutes. Boom lifting, boom descending, and bucket inclining forwards and backwards will be conducted repeatedly.
2. Boom will be lifted to the highest position, bucket will be inclined backwards to the largest position, and then the engine will be closed.
3. Control handle of working device will be controlled so that the bucket will roll over under dead load and discharge oil liquid in the rotating bucket cylinder; after the bucket has been rotated to a suitable position, control handle of working device will be pushed forward so that the boom will descend under dead load and discharge oil liquid in the boom cylinder.
4. Oil discharge ball valve in the bottom of hydraulic oil tank will be loosened to discharge dirt oil that is collected in the vessel. Meanwhile, filler cap will be loosened to accelerate oil discharge process.
5. Blind flange in the bottom of the oil tank will be dismantled; filler and all filter elements of oil suction and return ports in the oil tank will be cleaned. If filter element is damaged, it must be replaced.
6. Blind flange and oil discharge ball valve will be tightened again.
7. Stipulated hydraulic oil will be filled from the filler in the top of the hydraulic oil tank to the scale  $\pm 10\text{mm}$  of the liquidometer. Then the filler cap will be tightened. Filter element of filler cannot be removed for directly filling oil in the oil tank.
8. The engine will be started, boom will be lifted and descended and bucket will be inclined forward and backward for two times to three times. In addition, it will be steered towards the left by the largest angle so that hydraulic oil is filled in the oil cylinder and oil pipe. Then, the engine will be operated for idling for five minutes to discharge air in the system.
9. The engine will be shut down, oil level will be checked and oil will be filled if it is not enough.

### **Ventilation filter of hydraulic system and replacement**

The filter will be replaced for once every 1000 hours.

Filter cannot be cleaned but can be replaced.





### **Scavenge filter of hydraulic system and replacement**

Scavenge filter will be replaced for once every 1,000 hours.

1. Cover and hood will be dismantled.
2. Filter will be dismantled.
3. New filter will be installed.
4. Sealing ring of the hood will be checked when installing.

## Lubricating

### Bearing and lubricating

If the machine has been regularly and correctly lubricated, it can greatly prolong lifetime of bushing and axle pin.

Bearing lubricating mainly has two purposes:

1. Lubricating grease will be added to bearing to reduce friction between pin and bushing.
2. Old lubricating grease that may contain impurities will be replaced. Lubricating grease in the interior space of the outside seal will absorb dirt. Water and dirt will be prevented from entering the bearing.

Before lubricating, filler and grease gun of lubricating grease will be cleaned to prevent dirt and sand from filling in the interior part via filler of lubricating grease.

The bearing will be lubricated until new lubricating grease is squeezed from outside seal, which is shown in P185.



### Detailed utilization rules for oil and coolant

#### Fuel

1. Fuel pump is precision device. If fuel contains water or sundries, fuel pump cannot work normally.
2. You shall be very careful when replacing or filling fuel. Sundries cannot enter!
3. Fuel shall be used strictly in accordance with mark number specified in the manual.
4. Fuel will be solidified under low temperature (especially when the temperature is lower than  $-15^{\circ}\text{C}$ ), therefore, fuel shall be replaced according to different ambient temperature.
5. To prevent water vapor in air from coagulation and entering into fuel tank, after work is completed, it shall be filled with fuel.
6. If fuel cannot be absorbed or oil filter has been replaced just now when starting, air in the circuit shall be discharged at first.
7. Fuel shall be used strictly in accordance with below mark numbers:
  - 0# diesel (minimum temperature is at least  $4^{\circ}\text{C}$ )
  - 10# diesel (minimum temperature is at least  $-5^{\circ}\text{C}$ )
  - 20# diesel (minimum temperature is at least  $-14^{\circ}\text{C}$ )



-35# diesel (minimum temperature is at least -29°C)

-50# diesel (minimum temperature is at least -44°C)

8. There is a filter screen at oil-taking joint of fuel delivery pump, which is used to filter impurities in the diesel. This filter screen will be cleaned regularly.
9. Users shall fill qualified diesel in formal gas station, otherwise, the glib will be easily blocked. Our company will not be responsible for fault due to utilization of disqualified diesel.

### **Engine oil**

1. As different brands of engine oil have different formulas, mixed use may cause adverse influence to the engine.
2. It is strictly prohibited to use poor-quality engine oil. Otherwise, it will cause serious damage to the engine. Incurred fault will not obtain warranty.
3. When engine oil becomes thin, thickened and black and loses viscosity, engine oil must be replaced in time. Recommended replacement cycle is 250 hours.
4. When replacing engine oil, engine oil filter must be replaced at the same time. Users must use engine oil filter with high quality.

### **Coolant**

1. To prevent incurred incrustation from blocking the radiator or affecting cooling performance, antifreeze stipulated by Shandong Lingong must be used as coolant of the engine all the year around. It is strictly prohibited to use water as coolant.
2. If the engine is too hot, coolant shall be added after the engine has been cooled.
3. Coolant will be added to the stipulated height. If the coolant level is too low, the engine will be too hot and cooling system will be corroded.
4. As the engine will easily generate overheating phenomenon in hot weather with the temperature of more than 30°C, vehicle will be parked in shady and cool place.
5. After operation is completed, low-speed operation must be conducted for five minutes and the engine can be closed after water temperature has been reduced to prolong lifetime of the engine.
6. Anti-freezing agent is flammable product; antifreeze need be filled away from the open fire.
7. Antifreeze shall be replaced every year.



8. 100% of anti-freezing agent cannot be used as coolant.
9. When filling, different antifreezes will be used according to environmental conditions. Recommended selection scope:
  - a) -25 # will be selected when the environmental temperature is at least -15°C.
  - b) -35 # will be selected when the environmental temperature is at least -25°C.
  - c) -45 # will be selected when the environmental temperature is at least -35°C.
10. Antifreeze is used as coolant especially when environmental temperature is too low and altitude is high. Antifreeze has functions of anti-freezing, corrosion prevention, cavitation erosion prevention, scale prevention, high boiling point and so on.
11. High-quality antifreeze refers to qualified brand tested by testing station designated by the nation. Seeing from the appearance: limpid, transparent, without impurity, not muddy and without pungent smell. Outer package of the product shall have name of manufacturer, product specification and specific instructions.
12. Utilization of poor quality antifreeze cannot prevent freezing and boiling, but will accelerate corrosion of cooling system.

### **Brake fluid**

1. Brake fluid of different brands cannot be mixed. If replacing oil that is different from brake fluid that is being used, brake fluid that is being used will be discharged completely. It can be replaced and used after conducting feasibility test. Otherwise, Shandong Lingong Construction Machinery Co., Ltd. will not be responsible for accidents and brake invalidity due to mixed use of brake fluid or replacement problem.
2. To better maintain and use your machine, you need use brake fluid stipulated by Shandong Lingong.

### **Lubricating oil**

1. Lubricating oil can prevent abrasion and noise of the junction surface.
2. Connector that is not involved in the manual (such as joint, adapter sleeve) is disposed when overhauling and lubricating oil is not required. If some parts are not flexible as they have not been used for a long time, lubricating oil will be used.

3. Lubricating oil that has been leaked will be cleared when filling lubricating oil.

### **Storage of oil**

1. Water, dirt and other impurities will be avoided.
2. To guarantee quality of long-term stored oil, the principle of first in first out shall be abided by (oil whose storage period is the longest and is within the effective period shall be used at first).

### **Filter**

1. Filter is the important safety part, which can prevent impurities in fuel from entering important devices to cause fault. Filter will be regularly replaced. Maintenance cycle of filter is shown in the "P186 table of maintenance cycle". When working environment becomes severe, time interval of replacing filter will be shortened.
2. Paper filter element cannot be cleaned after using, which shall be replaced with new filter element.
3. When replacing new filter, oil filter shall be checked to confirm whether there is metal particle or not.

If having, you must contact repair personnel.

4. Package of new filter cannot be opened before use.
5. Special filter accessories of Shandong Lingong will be used.
6. Replacement steps are shown in the instruction on the surface of the filter or enclosed with the filter.



## Selection of oil

### Table of oil selection

Oil Category	Standard	Recommended viscosity at varying ambient temperatures											Capacity	Remark
		-50	-40	-22	-4	14	32	50	68	86	104	122°F		
		-50	-40	-30	-20	-10	0	10	20	30	40	50°C		
Engine oil	SAE J183-2013	CF-4 5W-40											20L	grade CF-4 or above
		CF-4 10W-30												
		CF-4 15W-40												
		CH-4 5W-40											20L	DDE & other Tier III engine
		CH-4 10W-30												
		CH-4 15W-40												
Transmission oil	SAE J183-2013	CH-4 15W-40											(17.1+4.7)L	
Gear oil	API 1560-2013	GL-5 75W/90											28+2×6 L 24+2×6 L	
		GL-5 80W/90												
		GL-5 85W/90												
		GL-5 85W/140												
Hydraulic oil	ISO 11158-2009	L-HS32											250L	VG46
		L-HV46												
		L-HM46												
		L-HV68												
Brake fluid	SAE J1703-2012	DOT3											2×2L	
Grease	ISO 6743-1987	NLGI2											—	
		NLGI3												
		EP2												
		EP3												
Antifreeze	ISO 6743-1987	-35											45±2L	
		-45												

Note: filling quantity listed in the table is just for reference, which will be subject to oil inspection standard.

### Diagram of lubricating part of loader

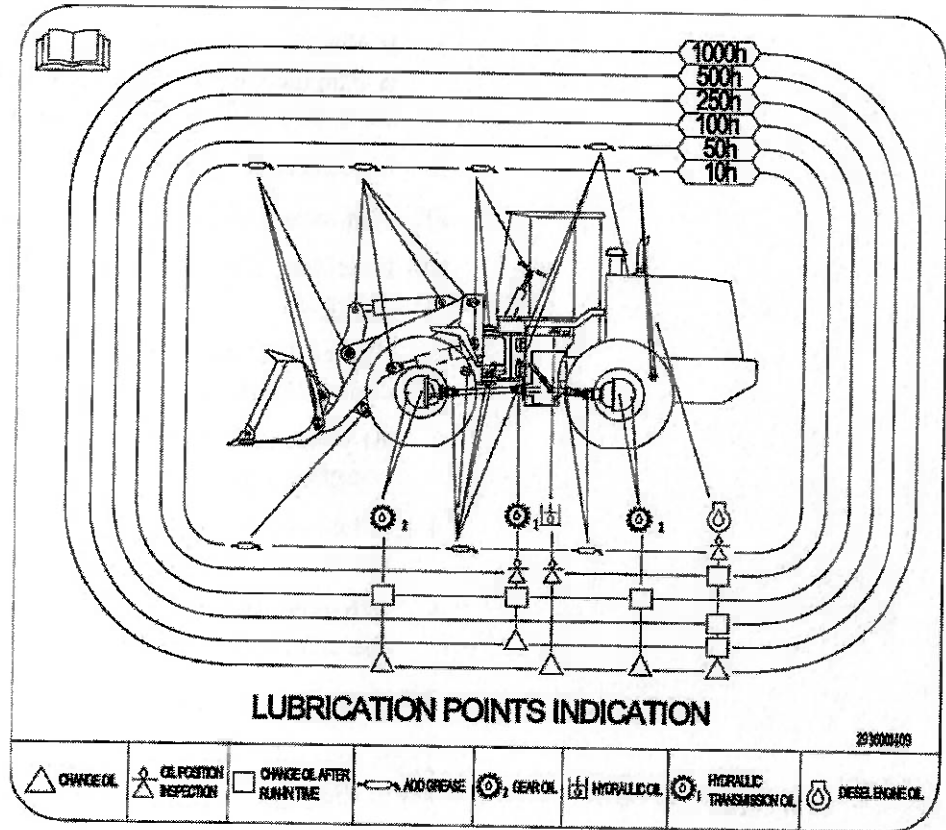

### Detailed rules for maintenance of electrical system

1. If electric wire is under damp environment or insulator is damaged, electrical system will easily leak electricity to cause dangerous accident.
2. Maintenance of parts related to electric system:
  - a) Tightness and damage of fan belt will be checked;
  - b) Liquid level of electrolyte of the storage battery will be checked.
  - c) Electric components that have been installed cannot be dismantled at will.
3. Any electric component cannot be added unless the company approves.
4. When cleaning the machine or using under rainy and snowy environment, electrical system will be kept dry.
5. When constructing by the sea, corrosion of sea water to the electrical system will be prevented.

### Maintenance tools

Tools for maintenance are shown in the tools in the packing list of the product.

### Maintenance table

Maintenance conducted every ten hours (day)

Measures	Page
Check engine oil level	150
Check coolant level	159
Check oil level of fuel tank	153
Check sealing of hydraulic system of working device	
Check sealing of steering hydraulic system	
Check sealing of foot braking system	
Check braking reliability and flexibility	
Check circuit and electric elements of electrical system to confirm whether they are normal or not	
Fill lubricating grease to fan shaft of diesel engine, hinge joints of front and rear frames, transmission shaft, swing hinge joint of rear axle and all hinge joints of working device.	180
Check other abnormalities	
Check oil of torque converter to confirm whether it is damaged or not and whether there is oil pumping phenomenon or not.	





## Operation & Maintenance Manual for L968F Wheel Loader

Maintenance conducted every 50 hours (week)

Maintenance conducted every ten hours will be conducted at the same time

Measures	Page
Clean filter element of air conditioning	
Check and adjust tightness of fan belt	161
Check transmission oil level	165
Check hydraulic oil level	177
Check brake fluid level of booster pump	
Check and tighten connecting bolts of all transmission shafts	
Check and tighten connecting bolts of rim	173
Check and tighten connecting bolts of brake caliper	
Check and tighten connecting bolts of Bucket teeth	

Maintenance conducted every 100 hours

Maintenance conducted every ten hours and every 50 hours will be conducted at the same time

Measures	Page
Replace engine oil	150
Replace engine oil filter element	151
Clean radiator set	160
Clean oil filter of fuel tank	
Discharge sediment from fuel tank	154
Replace gear oil of front and rear axles	169
Replace transmission oil	166
Replace transmission oil filter element	167



Maintenance conducted every 250 hours (month)

Maintenance conducted every ten hours, every 50 hours and every 100 hours will be conducted at the same time

Measures	Page
Replace engine oil (first time: 100 hours)	150
Replace engine oil filter element (first time: 100 hours)	151
Check storage battery, clean surface of binding post, coat thin Vaseline.	162
Check connecting bolt of working device to confirm whether it is loose or not and whether welding joint has crack or not.	
Check connecting bolt of front and rear frames to confirm whether it is loose or not and whether welding joint has crack or not.	
Check connection between front and rear axles and frame to confirm whether it is loose or not.	
Check connection between engine and holder or frame to confirm whether it is loose or not.	
Check connection between transmission and frame to confirm whether it is loose or not.	
Measure tyre pressure (26.5-25)	172
Pressure of front tyre (MPa) $0.40 \pm 0.01$	
Pressure of rear tyre (MPa) $0.35 \pm 0.01$	
Measure tyre pressure (23.5-25)	172
Pressure of front tyre (MPa) $0.39 \pm 0.01$	
Pressure of rear tyre (MPa) $0.33 \pm 0.01$	

Maintenance conducted every 500 hours (quarter)

Maintenance conducted every ten hours, every 50 hours, every 100 hours and every 250 hours will be conducted at the same time

Measures	Page
Replace fuel filter element	154
Replace air filter element	157
Replace filter element of air conditioning	175
Replace brake fluid	
Check and clean oil storage screen of booster pump	
Check and adjust brake gap of braking system	
Check wear situation of brake disc and friction plate of braking system, if necessary, they will be replaced.	



## Operation & Maintenance Manual for L968F Wheel Loader

Maintenance conducted every 1,000 hours (half year)

Maintenance conducted every ten hours, every 50 hours, every 100 hours, every 250 hours and every 500 hours will be conducted at the same time

Measures	Page
Replace gear oil of front and rear axles (first time 100 hours)	169
Check the braking system to confirm whether there is any leakage or not	
Replace filter element of transmission breather	
Replace transmission oil (first time 100 hours)	166
Replace transmission oil filter element (first time 100 hours)	167
Replace scavenge filter element of hydraulic oil tank	179
Replace guide filter element of hydraulic oil (guide control)	
Replace hydraulic oil of hydraulic system	177
Check the hydraulic system to confirm whether there is any leakage or not	
Clean hydraulic oil tank	
Check gap and abrasion between axle pin and sleeve of all hinge joints	

Maintenance conducted every 2,000 hours

Maintenance conducted every ten hours, every 50 hours, every 100 hours, every 250 hours, every 500 hours and every 1,000 hours will be conducted at the same time.

Measures	Page
Replace hydraulic oil of hydraulic system (first time 1000 hours)	177
Replace antifreeze (or replace for once in every year, subject to the earlier one)	159
Check performances of torque converter, transmission, differential mechanisms of front and rear axles and wheel reducer.	
Check sealing of multi-way valve and hydraulic oil cylinder and measure system working pressure by testing natural settling volume of hydraulic oil cylinder.	
Check welding joint and stressing parts of rim and calibrate its deformation.	

# System principle diagram

## Transmission system

Transmission system is composed of hydraulic torque converter, transmission, transmission shaft, front and rear drive axles and wheel. Principle of transmission system is shown in the below figure:

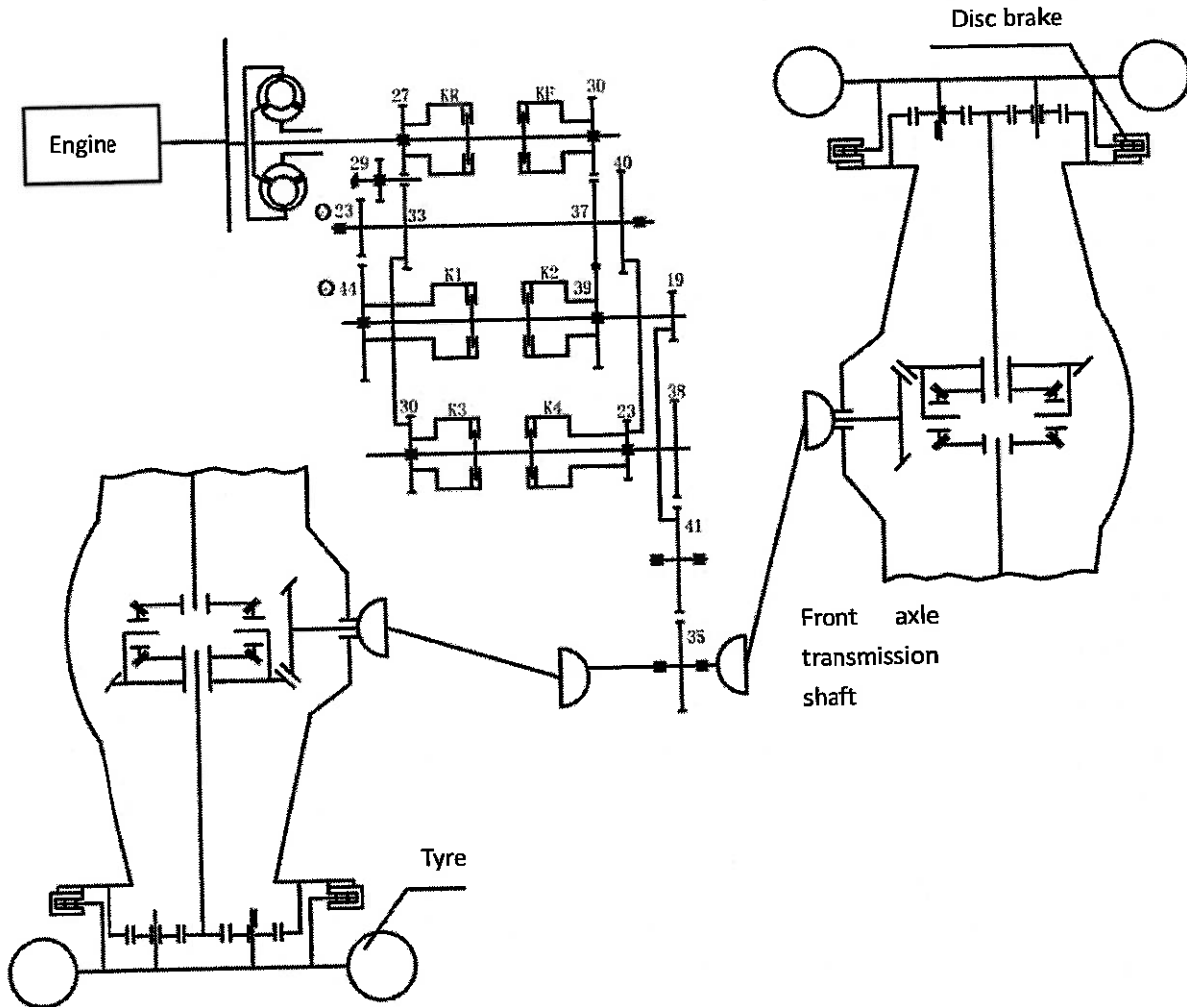

Transmission system principle diagram

## Hydraulic system

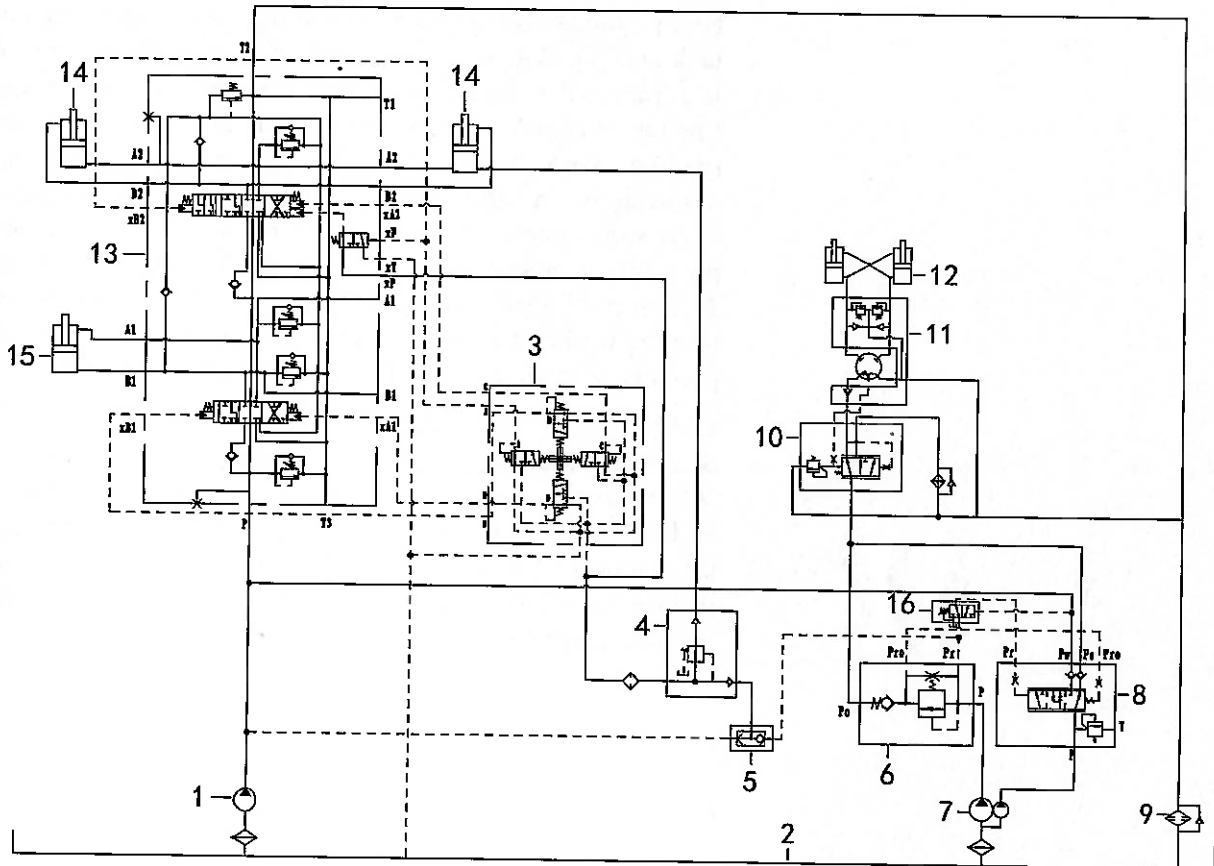

1. Working pump
2. Hydraulic oil tank
3. Pilot valve
4. Pressure selection valve
5. Shuttle valve
6. Flow signal valve
7. Double pump
8. Switch valve
9. Filter Hydraulic oil radiator
10. Pressure-gradient control valve
11. Steering gear
12. Steering cylinder
13. Multi-way valve
14. Boom cylinder
15. Oil cylinder of rotating bucket
16. Sequence valve

Principle diagram of pilot control hydraulic system  
(duplex valve)

As shown in the figure, hydraulic system of working device adopts pilot control, which is composed of working pump, multi-way valve, pilot valve, pressure selection valve, boom cylinder, oil cylinder of rotating bucket, hydraulic oil tank and pipeline accessories. KM300-II-21 multi-way valve is duplex valve. Rotating bucket is divided into unloading (incline forward), neutral position and collecting bucket (incline backward); boom is divided into floating, descending, neutral position and lifting to achieve operation control of working device of the loader. Set pressure of safety valve of hydraulic system is between 20.7 and 21.2MPa, overload pressure of large cavity of rotating bucket is between 22.5 and 23.5MPa, and overload pressure of small cavity is between 11.5 and 12.5MPa.

L968F adopts hydraulic articulated steering system. Steering hydraulic system is load-sensing hydraulic system. When steering, this system will supply oil to the steering hydraulic system at first, residual oil will flow to hydraulic oil radiator for cooling. Safety valve is set on the pressure-gradient control valve. Set pressure of the system is 16MPa, which is shown in the figure.

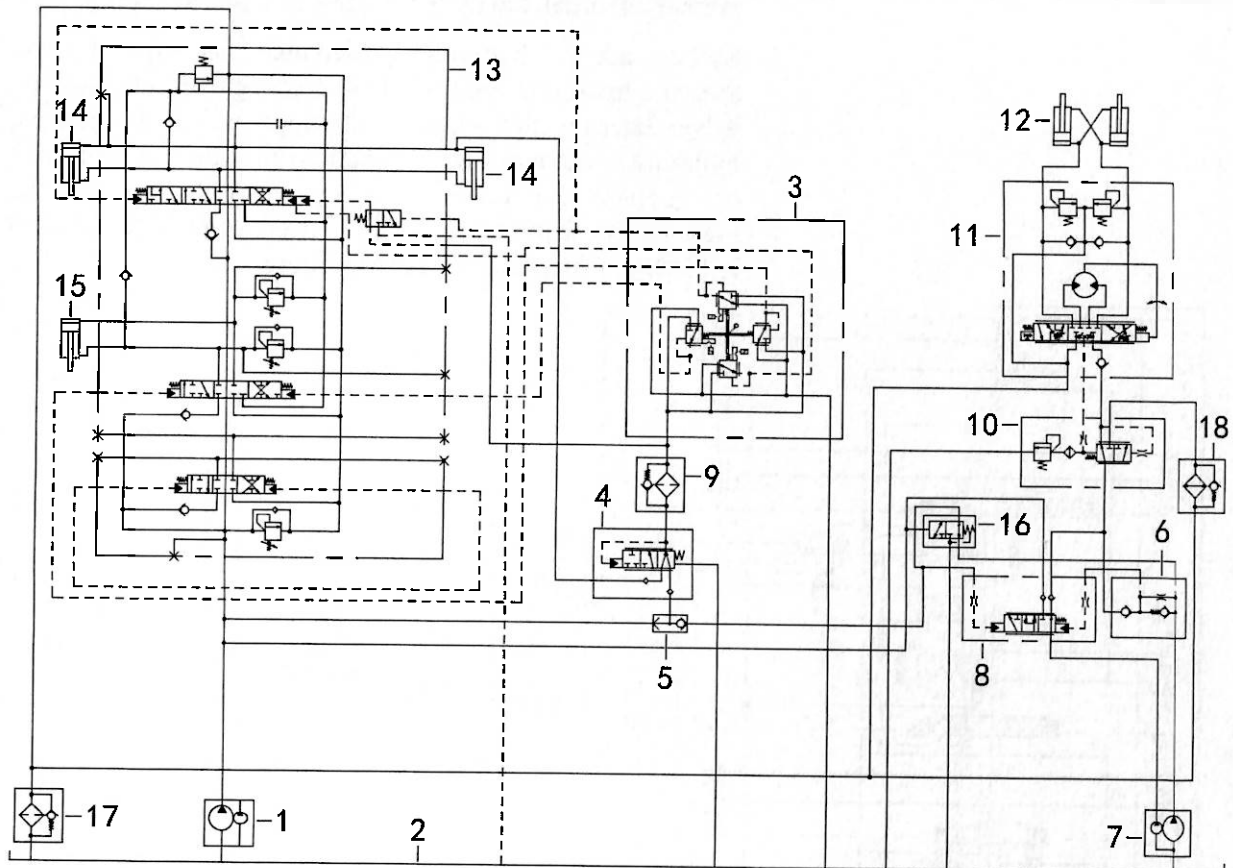

- 1. Working pump    2. Hydraulic oil tank    3. Pilot valve
- 4. Pressure selection valve    5. Shuttle valve
- 6. Flow signal valve    7. Double pump    8. Switch valve
- 9. Pilot filter    10. Pressure-gradient control valve
- 11. Steering gear    12. Steering cylinder    13. Multi-way valve
- 14. Boom cylinder    15. Oil cylinder of rotating bucket
- 16. Sequence valve    17. By-pass oil filter
- 18. Hydraulic oil radiator

**Principle diagram of hydraulic system (triple valve)**

As shown in the figure, hydraulic system of working device adopts pilot control, which is composed of working pump, multi-way valve, pilot valve, pressure selection valve, boom cylinder, oil cylinder of rotating bucket, hydraulic oil tank and pipeline accessories. KM300-III-21 multi-way valve is triple valve. Rotating bucket is divided into unloading (incline forward), neutral position and collecting bucket (incline backward); boom is divided into floating, descending, neutral position and lifting to achieve operation control of working device of the loader. Set pressure of safety valve of hydraulic system is between 20.7 and 21.2MPa, overload pressure of large cavity of rotating bucket is between 22.5 and 23.5MPa, and overload

pressure of small cavity is between 11.5 and 12.5MPa.

L958F adopts hydraulic articulated steering system. Steering hydraulic system is load-sensing hydraulic system. When steering, this system will supply oil to the steering hydraulic system at first, residual oil will flow to hydraulic oil radiator for cooling. Safety valve is set on the pressure-gradient control valve. Set pressure of the system is 16MPa, which is shown in the figure.

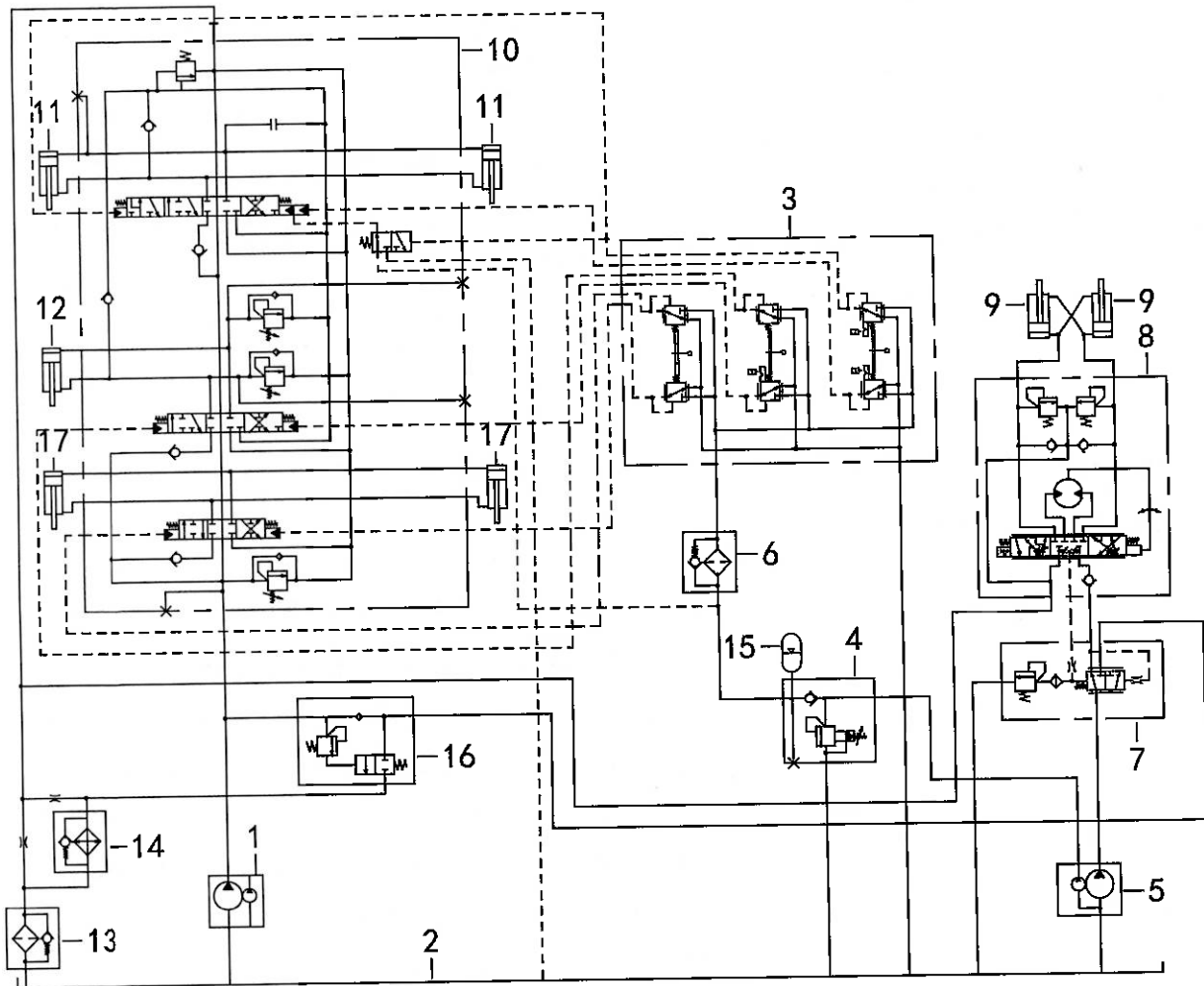

- 1. Working pump 2. Hydraulic oil tank 3. Pilot valve
- 4. Pressure selection valve 5. Double pump 6. Pilot filter
- 7. Pressure-gradient control valve 8. Steering gear
- 9. Steering cylinder 10. Multi-way valve
- 11. Boom cylinder 12. Oil cylinder of rotating bucket
- 13. Filter Hydraulic oil radiator 14. Hydraulic oil radiator
- 15. Accumulator 16. Uninstal valve 17. Grab fork cylinder

Principle diagram of pilot control hydraulic system  
(L068FW2215A39EM)



As shown in the figure, hydraulic system of working device adopts pilot control, which is composed of working pump, multi-way valve, pilot valve, pressure selection valve, boom cylinder, oil cylinder of rotating bucket, hydraulic oil tank and pipeline accessories. KM300- III-21 multi-way valve is triple valve. Rotating bucket is divided into unloading (incline forward), neutral position and collecting bucket (incline backward); boom is divided into floating, descending, neutral position and lifting to achieve operation control of working device of the loader. Set pressure of safety valve of hydraulic system is between 20.7 and 21.2MPa, overload pressure of large cavity of rotating bucket is between 22.5 and 23.5MPa, and overload pressure of small cavity is between 11.5 and 12.5MPa.

L968F adopts hydraulic articulated steering system. Steering hydraulic system is load-sensing hydraulic system. When steering, this system will supply oil to the steering hydraulic system at first, residual oil will interflow with hydraulic oil from work pump. Safety valve is set on the pressure-gradient control valve. Set pressure of the system is 16MPa, which is shown in the figure.

## Braking system

Braking system is used to reduce speed or park when driving and park for a long time on flat ground or slope. As shown in the principle diagram, the braking system includes service braking system, emergency and parking brake system.

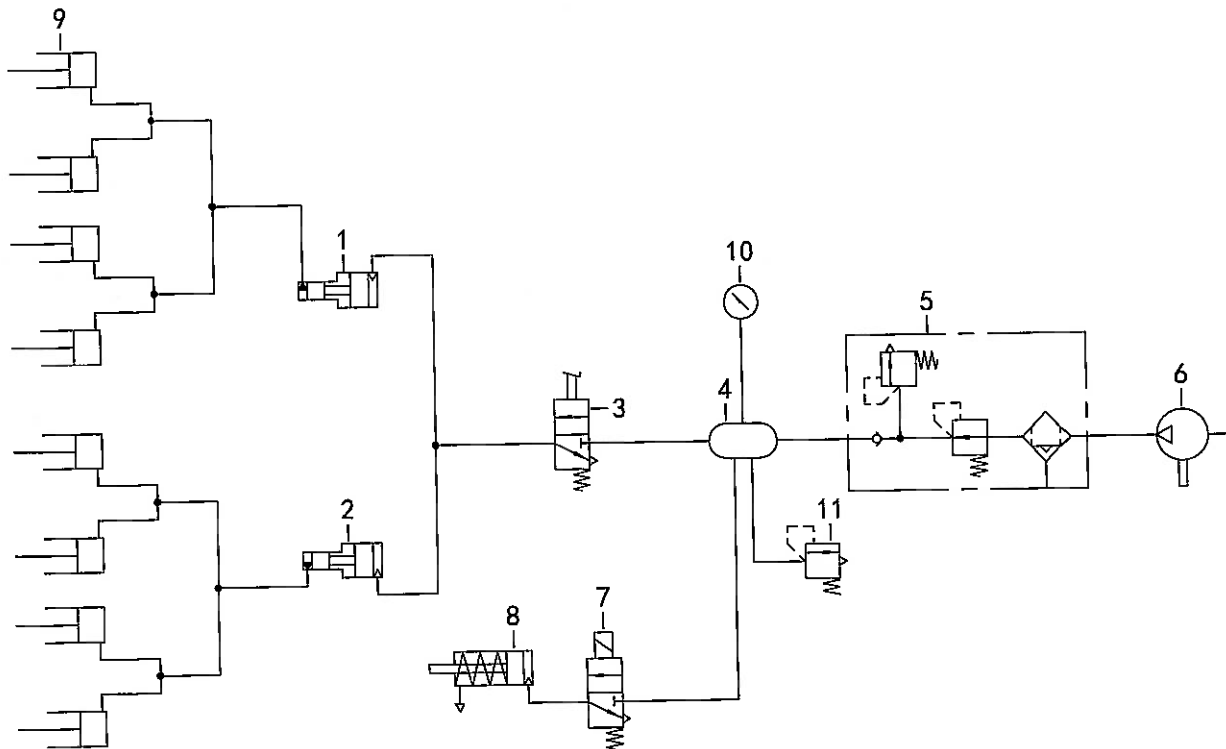

- 1. Air booster pump of front axle
- 2. Air booster pump of rear axle
- 3. Foot brake valve
- 4. Air storage tank
- 5. Oil-water separation combination valve
- 6. Air compressor
- 7. Brake solenoid valve
- 8. Parking brake chamber
- 9. Brake caliper
- 10. Air pressure gauge
- 11. Relief valve

Principle diagram of braking system (single brake pedal)

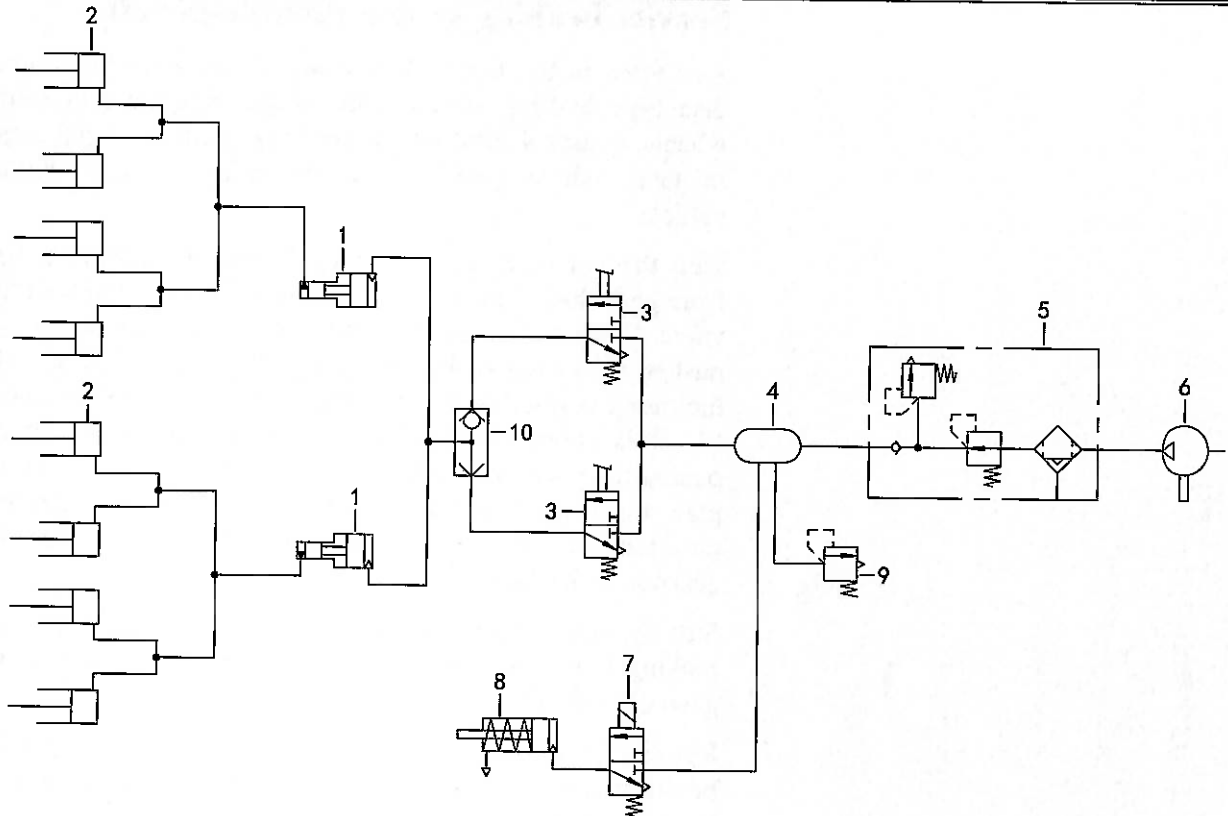

1. Air booster pump   2. Brake caliper   3. Foot brake valve  
 4. Air storage tank   5. Oil-water separation combination valve   6. Air compressor   7. Brake solenoid valve  
 8. Parking brake chamber   9. Safety valve  
 10. Shuttle valve

Principle diagram of braking system (double-pedal)

### Service braking system (Single pedal)

As shown in the figure, this system is air over hydraulic disc type braking system with single pipeline and four wheels. It uses 4 front and 4 rear brake calipers, eight sets in total, which greatly improves safety of the whole vehicle.

When the brake pedal is stamped in the driving process, compressed air in the air storage tank 4 will enter into air chamber of air booster pump via brake valve 3 to boost piston of the booster pump and convert to oil way (oil pressure is about 14MPa). The brake fluid will push piston of disc type brake so that the friction plate will be pressed on the brake wheel of the brake disc to reach the purpose of speed reduction or parking.

When the brake pedal is loosened, compressed air of the booster pump is discharged from the brake valve into air, and brake state is cancelled.

### **Service braking system (double-pedal)**

As shown in the figure, this system is air over hydraulic disc type braking system with single pipeline and four wheels. It uses 4 front and 4 rear brake calipers, eight sets in total, which greatly improves safety of the whole vehicle.

Step the left brake pedal during driving. Compressed air from gasholder 4 goes through air brake valve 3 and shuttle valve 10 enters in gas chamber of gas booster pump 1, pushes the piston of booster pump, the other chamber of the pump is filled with brake fluid (the maximum pressure of oil is about 14MPa), then high pressure brake fluid pushes the piston of caliper disc brake to make the friction plate touch the brake discs, which can brake the vehicle; pneumatic signal will be output to cut off the power of gearbox at the same time.

Step the right brake pedal during driving. The principle of braking is the same as using the left pedal, but power of gearbox will not be cut off.

Release the brake pedal, and gas in the booster pump will be discharged into the atmosphere through the brake valve, the braking state will be removed.

### **Emergency and parking brake system**

As shown in the figure, this system adopts power-driven gas-control internal shoe type braking system. When driving, lightly rotate operation button of brake solenoid valve 7, the button will pop up automatically, and then compressed air in the air storage tank 4 will flow into parking brake chamber 8 via brake solenoid valve 7, and enable the spring to push the piston away, so as to release the brake, and cancel braking; when parking, press operation button of brake solenoid valve 7, compressed air in parking brake chamber 8 will be discharged into air via exhaust port of brake solenoid valve 7, and the brake will be pulled up under the action of spring force, so as to reach the purpose of braking.

When the system pressure is less than 0.4MPa, brake solenoid valve 7 will be power off automatically, which enables compressed air in parking brake chamber 8 to be discharged into air via solenoid valve, to realize emergency braking, thus protecting vehicle and personnel safety.



## Electrical system

Electrical system includes: storage battery, starting motor, charging generator, instrument, switch, lamp and other power equipment.

Voltage of the system is DC 24V, minus earth, line adopts single wire system. You shall carefully read principle diagram of circuit of electrical system for mutual relationship and working principle of all power equipment.

