

AP65

Quality Changes the World



# Tandem Roller

## STR130C-8C

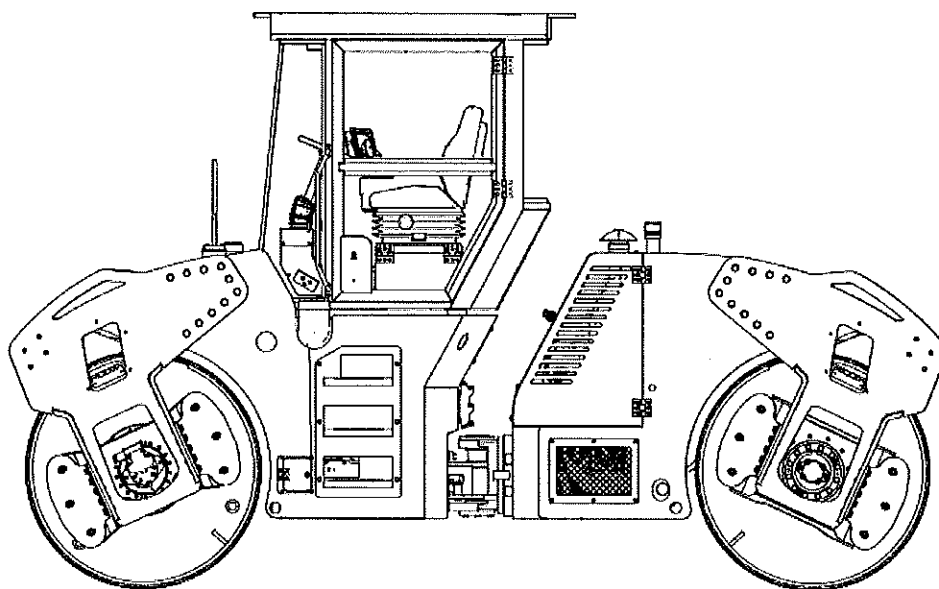

---

**Parts Book**

209A

# Parts Book

**STR130C-8C**

**Roller**

---

Equipment No.    YZ2113CC2309



## **Overview**

This book provides illustrations and parts listings required to properly identify and order replaceable parts on your Sany machine.

If this book becomes damaged, lost or illegible, request a replacement copy from your Sany distributor.

In case you sell this machine, be sure to give this parts book to the new owner.

Improvements in the design may lead to changes in detail which may not be indicated in this book. Always consult your Sany distributor for the latest available information on your equipment or if you have questions regarding information in this book.

## **Storing this parts book**

This publication applies only to this specific machine and should not be used with any other machines.

Always keep this book available for reference.

## **Contact Details**

SANY Industry Town, Economic and Technological Development Zone, Changsha, Hunan China 410100

Tel: 0731-84031888

Fax: 0731-84031999

Service Hotline: 4008 87 8318

Complaint Hotline: 4008 87 9318

Email: Sanyservice@sany.com.cn

Website: www.sanyglobal.com

## **Sany Group Service Information System**

<http://sis.sanygroup.com>

Page header with parts code, and parts description

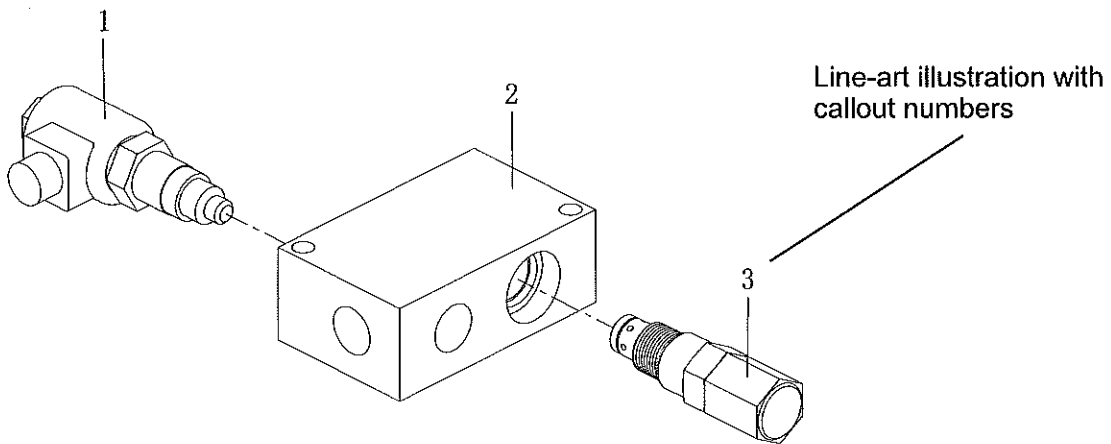

Page footer with page number, chapter title, machine model and product name

Page header with parts code, and parts description

INDEX: that matches callout numbers on previous illustration page

SEE PAGE: for page information of the part or assembly

INDEX	PART NO.	DESCRIPTION	QTY	SEE PAGE
1	B220401000459	Valve Assembly, Solenoid	1	
2	A820103010415	Change Valve Block, Cooling Oil Motor	1	
3	B220400000083	Relief Valve	1	

PART NO.: to be used along with DESCRIPTION to identify the part or assembly

DESCRIPTION: to be used along with PART NO. to identify the part or assembly

QTY: it indicates the number of each part used in this assembly

Page footer with page number, chapter title, machine model and product name

BLANK PAGE



# Table of Contents

<b>Group 1 STR130C-8S Sany Tandem Roller .....</b>	<b>1-1</b>
YLJ100000041 STR130C-8S Sany Tandem Roller .....	1-2
<b>Group 2 vibration drum assem.....</b>	<b>2-1</b>
YLJ005563219 vibration drum assem .....	2-2
14385045 Travel supporting in vibration end.....	2-6
12844503 Modulator, amplitude .....	2-8
12844646 Modulator, amplitude .....	2-10
12744699 Bearing seat component.....	2-12
<b>Group 3 Front carriage.....</b>	<b>3-1</b>
YLJ005417704 Front carriage .....	3-2
YLJ004954617 Diesel box assembly component .....	3-6
YLJ004677594 Rearview mirror bracket.....	3-8
13685018 Hose clip unit .....	3-10
YLJ004895853 The Maintenance Door.....	3-12
13445924 Battery component.....	3-14
13892932 Hose clip unit .....	3-16
<b>Group 4 controlling system assembly .....</b>	<b>4-1</b>
YLJ006656466 controlling system assembly .....	4-2
13352079 Display Mounting Rack .....	4-4
14155306 Steering Control System .....	4-6
14352067 Console bracket assembly .....	4-8
13175451 Electrical control penal component .....	4-12
YLJ004680731 side box .....	4-14
<b>Group 5 air .....</b>	<b>5-1</b>
YLJ005602041 air.....	5-2
<b>Group 6 Center hinge frame .....</b>	<b>6-1</b>
YLJ004859632 Center hinge frame .....	6-2
12364147 Steering Cylinder.....	6-6
14160181 Cylinder Assembly, Steering .....	6-8
12955991 Lock pin .....	6-10
<b>Group 7 Dynamical system.....</b>	<b>7-1</b>
YLJ005110467 Dynamical system .....	7-2
13920410 engine installation .....	7-4
14506058 pump connection.....	7-8

YLJ005110427 Cooling assembly .....	7-10
YLJ005110623 Exhaust System.....	7-14
YLJ005105952 Oil road and nearby installation .....	7-18

**Group 8 Hydraulic system assembly ..... 8-1**

14511191 Hydraulic system assembly.....	8-2
14511380 Traveling motor .....	8-6
13686364 Steering component .....	8-8
13448213 Crablke valve mounting.....	8-10
13686363 Priority valve assembly .....	8-12
14511533 Vibratory motor .....	8-14
13917318 Return Block assembly .....	8-16
14511708 Steering Pump .....	8-18
13686274 Fan valve mounting .....	8-20
14511747 Fan motor component.....	8-22
13916302 BLOCK OF collecting assembly .....	8-24
13918399 filter assembly.....	8-26
14512102 Triple Pump .....	8-28
A810201060027 Vibration switch valve installation.....	8-30
14513076 Radiator of vibratory system.....	8-32
14513087 Pipeline layout of brake and steering systems .....	8-34
14513010 Piping diagram of vibratory system .....	8-36
14512830 Piping diagram of traveling system .....	8-38
13989791 Braking valve mounting .....	8-40
YLJ005720436 Traveling motor .....	8-42

**Group 9 covering parts ..... 9-1**

YLJ005110634 covering parts .....	9-2
-----------------------------------	-----

**Group 10 rear frame ..... 10-1**

YLJ005103971 rear frame.....	10-2
14510385 oil tank.....	10-6

**Group 11 Bridging BeamComponent..... 11-1**

YLJ005651966 Bridging BeamComponent .....	11-2
13687649 Under scraper assem .....	11-4
YLJ005652578 Upper scraper assem. ....	11-6

**Group 12 water ..... 12-1**

YLJ005639941 water .....	12-2
--------------------------	------

**Group 13 Electrical system of roller ..... 13-1**

14511035 Electrical system of roller .....	13-2
13455256 Power assembly .....	13-4
14512008 Electrical Control Box Assembly .....	13-6

14514219 Electric system assembly of Control box .....	13-8
14173552 Electrical system , rear carriage.....	13-10
14388807 Electrical system , front carriage.....	13-14
YLJ005348321 Electrical harness assembly basic diagram .....	13-22
<b>Group 14 Driver's Cab Assy .....</b>	<b>14-1</b>
YLJ005573749 Driver's Cab Assy .....	14-2
130901000268B Cab(JRTR07A) .....	14-4
130901000269B JRTR07 double steel roller cab console body.....	14-6
JSS005361405 Cab body .....	14-8
JSS005364030 JRTR07A inner&outer-decoration assembly.....	14-10

BLANK PAGE

# Group 1

## STR130C-8S Sany Tandem Roller

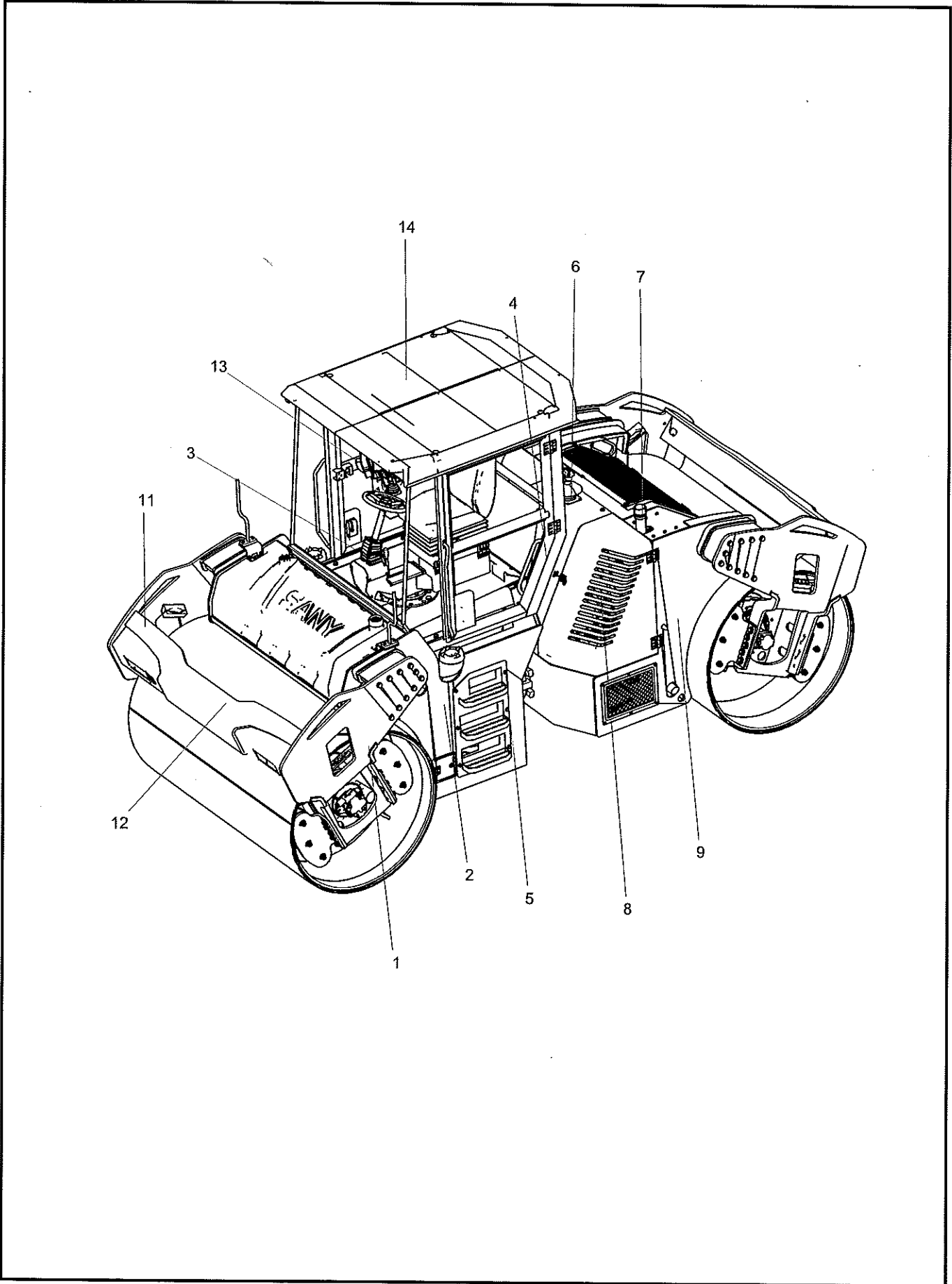

INDEX	PART NO.	DESCRIPTION	QTY	SEE PAGE
1	YLJ005563219	vibration drum assem	2	2-2
2	YLJ005417704	Front carriage	1	3-2
3	YLJ006656466	controlling system assembly	1	4-2
4	YLJ005602041	air	1	5-2
5	YLJ004859632	Center hinge frame	1	6-2
6	YLJ005110467	Dynamical system	1	7-2
7	14511191	Hydraulic system assembly	1	8-2
8	YLJ005110634	covering parts	1	9-2
9	YLJ005103971	rear frame	1	10-2
11	YLJ005651966	Bridging BeamComponent	2	11-2
12	YLJ005639941	water	1	12-2
13	14511035	Electrical system of roller	1	13-2
14	YLJ005573749	Driver's Cab Assy	1	14-2

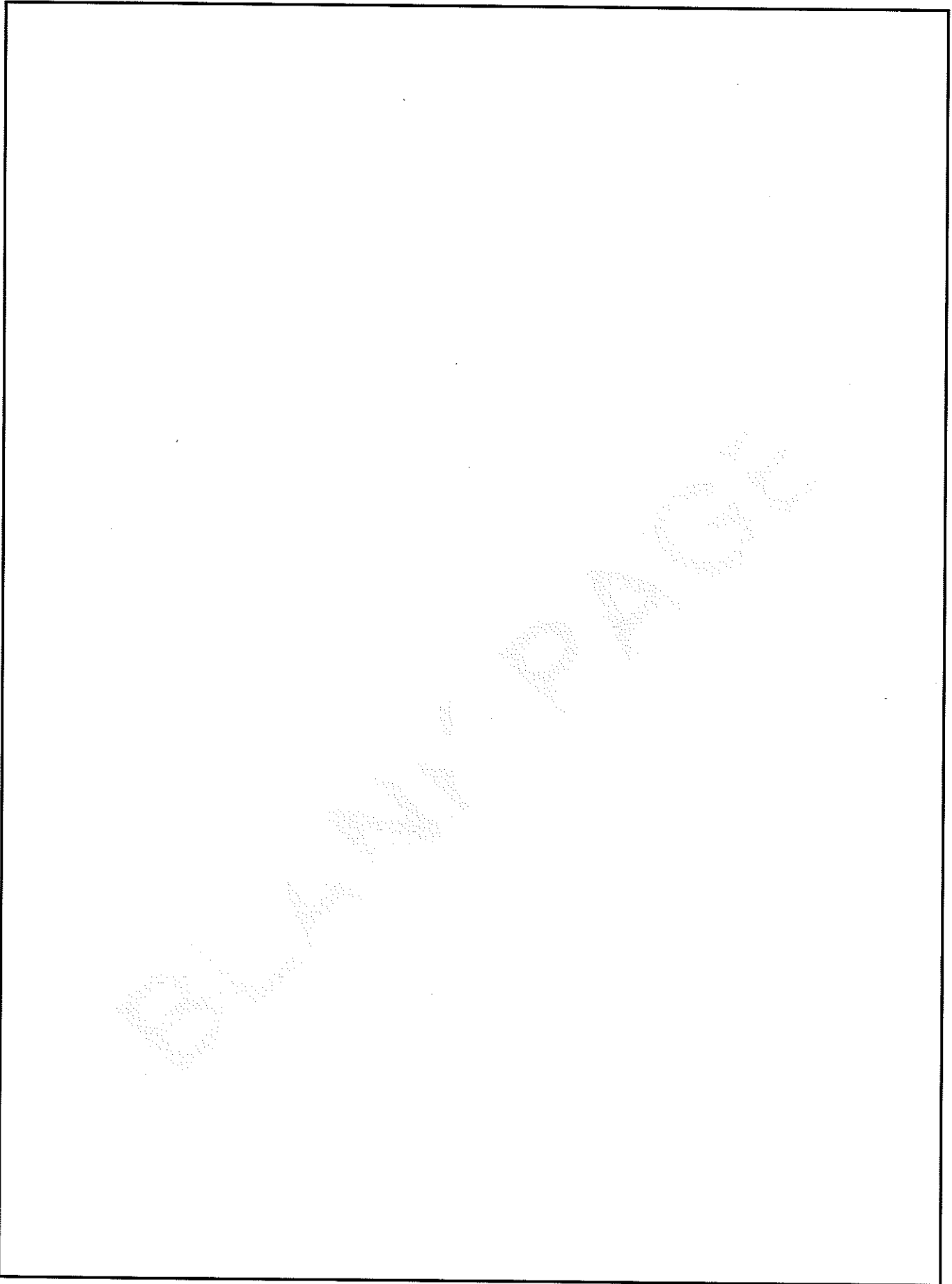



# Group 2

## vibration drum assem

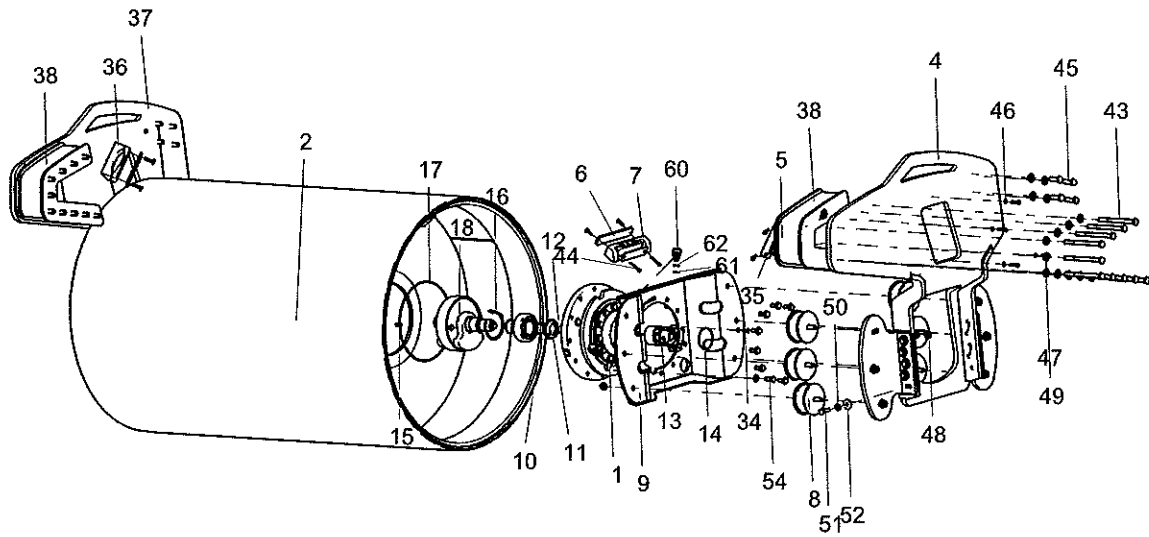

INDEX	PART NO.	DESCRIPTION	QTY	SEE PAGE
1	14385045	Travel supporting in vibration end	1	2-6
2	14160284	Roller Wheel	1	
3	14321843	vibration dummy club welding	1	
4	14321909	Fork leg	1	
5	14395896	Clamp	1	
6	14009225	Fixing plate	2	
7	14545154	Clamp	1	
8	60034012	Damp block	12	
9	13818666	Support plate welding	1	
10	A210204000131	Screw	4	
11	11405879	Retaining disc	1	
12	A210414000028	Retainer Ring	1	
13	61016820	Flexible Coupling	1	
14	A210609000284	O-ring	1	
15	A210509000037	Key	1	
16	A210416000006	Ring, Retainer	4	
18	12844503	Modulator, amplitude	1	2-8
34	A210111000026	Bolt	8	
35	14380664	Fixing plate	4	
36	14395968	Clamp	1	
37	14321920	Fork leg	1	
38	14321864	driving dummy club welding	1	
43	A210110000331	Bolt	20	
44	A210204000342	Screw	4	
45	A210111000062	Bolt	8	
46	A210405000011	Washer	12	
47	A210204000346	Screw	12	
48	A210315000005	Nut	24	
49	A210491000132	Washer	52	
50	A210491000118	Washer	58	
51	A210111000054	Bolt	20	
52	13867303	Shim	20	
54	A210114000007	Bolt	29	
60	60109047	Breather	1	
61	A210434000010	Washer	1	
62	13403379	Spacer	1	

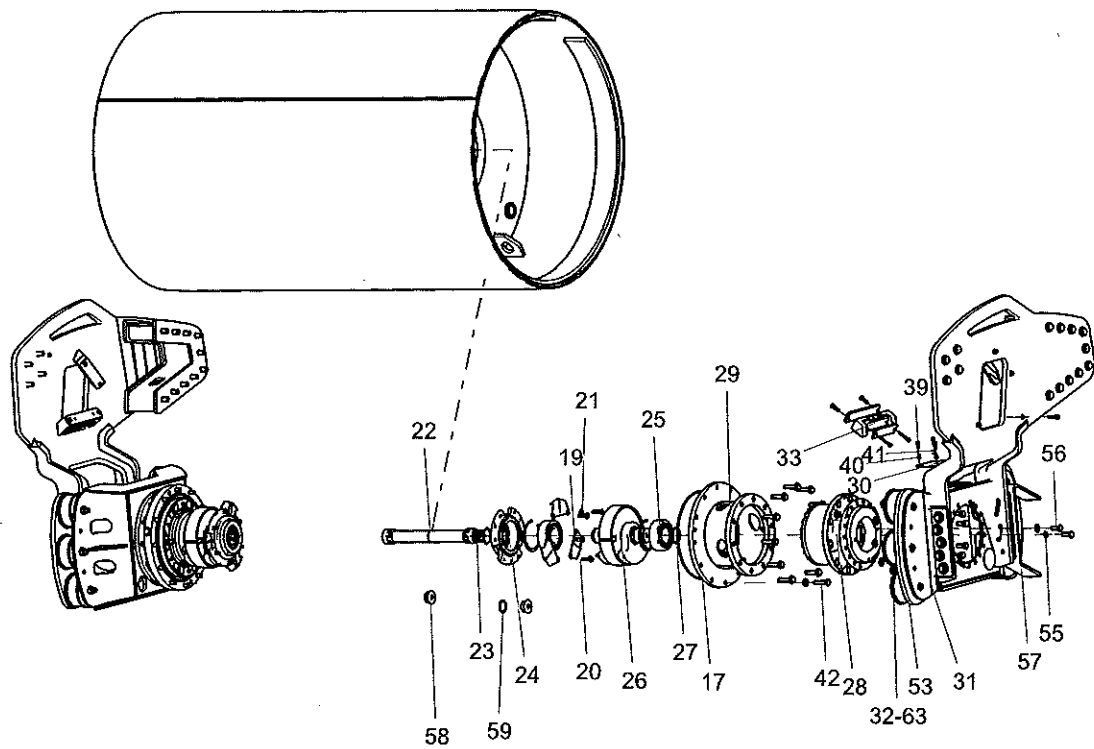

INDEX	PART NO.	DESCRIPTION	QTY	SEE PAGE
17	24002383	O-ring	2	
19	13311381	Scraper welding	6	
20	A210114000001	Bolt	12	
21	A210491000121	Washer	12	
22	60244891	Flexible Coupling	1	
23	A210204000356	Screw	8	
24	13309251	Intermediate bearing seat	2	
25	60231763	Rolling Bearing	4	
26	12844646	Modulator, amplitude	1	2-10
27	A210414000065	Retainer Ring	4	
28	61005880	Reducer	1	
29	12744699	Bearing seat component	1	2-12
30	12984281	Cover plate	2	
31	13817935	Support plate welding	1	
32	A210401000007	Washer	10	
33	14545153	Clamp	1	
39	A210111000090	Bolt	8	
40	A210405000007	Washer	8	
41	A210401000017	Washer	8	
42	A210114000012	Bolt	24	
53	14000982	Supporting Plate	4	
55	A210401000004	Washer	17	
56	A210111000053	Bolt	2	
57	14000983	Pedal	1	
58	A210333000007	Screw Plug	2	
59	A210434000020	Washer	2	
63	60082193	Screw	10	

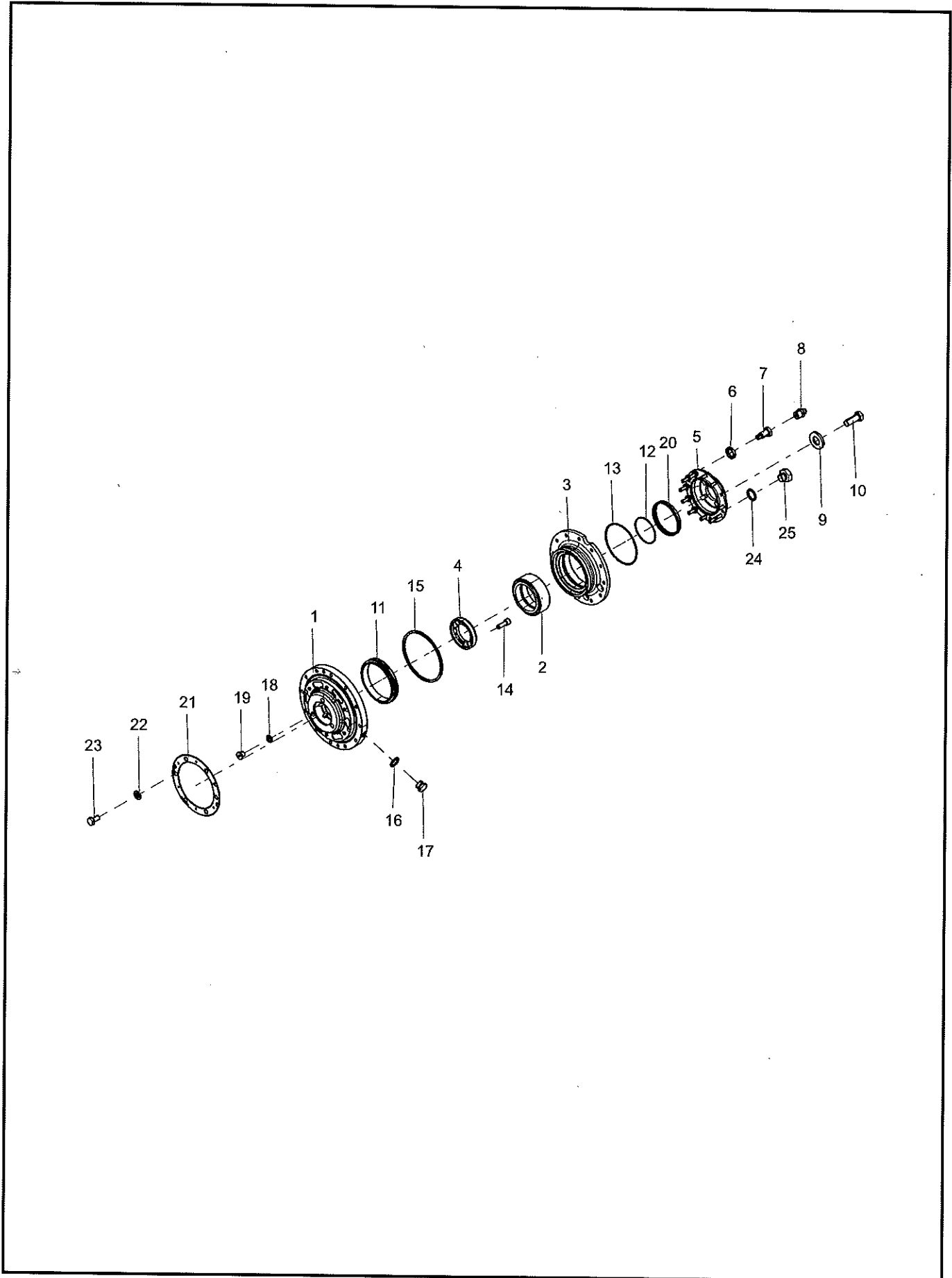

INDEX	PART NO.	DESCRIPTION	QTY	SEE PAGE
1	13977278	Vibratory end bearing holder	1	
2	A210628000009	Rolling bearing	1	
3	13309621	Connection sleeve	1	
4	A820201000779	Pressure cover	1	
5	13309783	End plate	1	
6	A210453000007	Washer	2	
7	13208018	Oil Cup Base	2	
8	A210804000002	Oil Cup	1	
9	A210491000118	Washer	12	
10	A210114000007	Bolt	12	
11	151402030066A	Oil seal	1	
12	A210609000013	O-ring	1	
13	A210609000035	O-ring	1	
14	A210204000221	Screw	12	
15	60035082	Felt Seal Ring	1	
16	A210434000011	Washer	3	
17	60033283	Magnetic screw plug	3	
18	A210434000007	Washer	3	
19	A210333000001	Plug, Screw	3	
20	A230101000302	FB Oil Seal	1	
21	12278981	Cover	1	
22	A210405000007	Washer	6	
23	A210111000088	Bolt	6	
24	A210453000004	Washer	1	
25	A210332000004	Screw Plug	1	

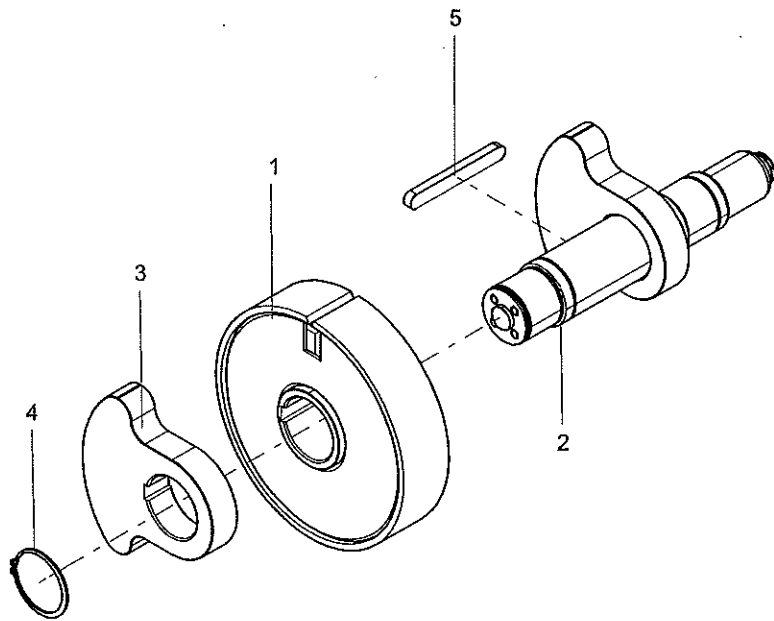



INDEX	PART NO.	DESCRIPTION	QTY	SEE PAGE
1	12844446	Movable block chamber welding	1	
2	13201312	Vibratory shaft	1	
3	12844477	Fixed eccentric block	2	
4	A880804040007	Retainer Ring	2	
5	A210509000088	Key	1	

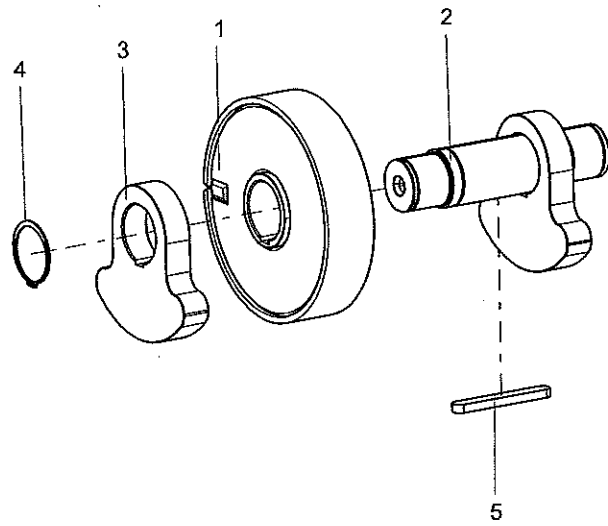

INDEX	PART NO.	DESCRIPTION	QTY	SEE PAGE
1	12844446	Movable block chamber welding	1	
2	13201192	Vibratory shaft	1	
3	12844477	Fixed eccentric block	2	
4	A880804040007	Retainer Ring	2	
5	A210509000088	Key	1	

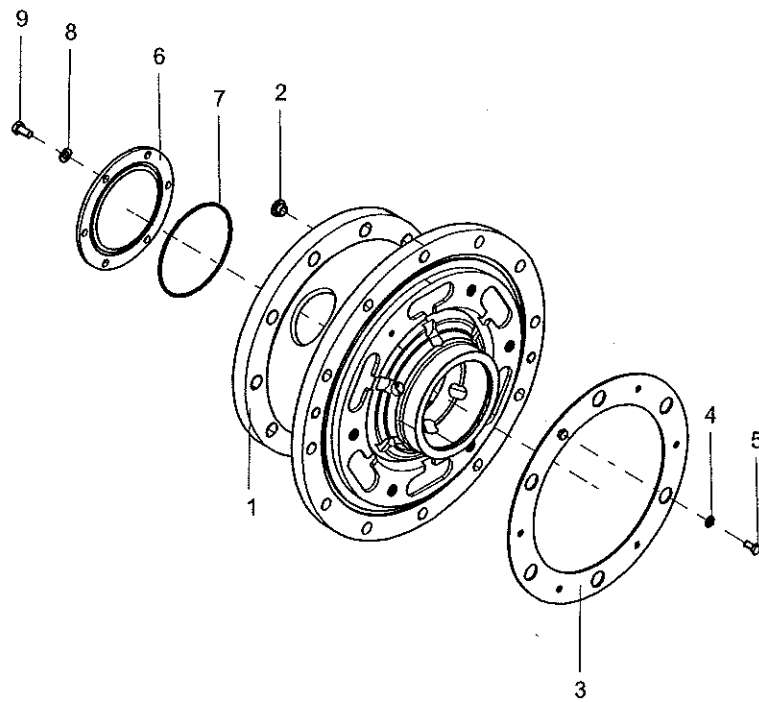

INDEX	PART NO.	DESCRIPTION	QTY	SEE PAGE
1	12732056	Bearing seat welding	1	
2	10891721	Threaded Cover	2	
3	12281495	Cover	1	
4	A210405000007	Washer	6	
5	A210111000088	Bolt	6	
6	13021799	End cover of bearing seat	1	
7	A210609000174	O-ring	1	
8	A210405000011	Washer	6	
9	A210111000011	Bolt	6	

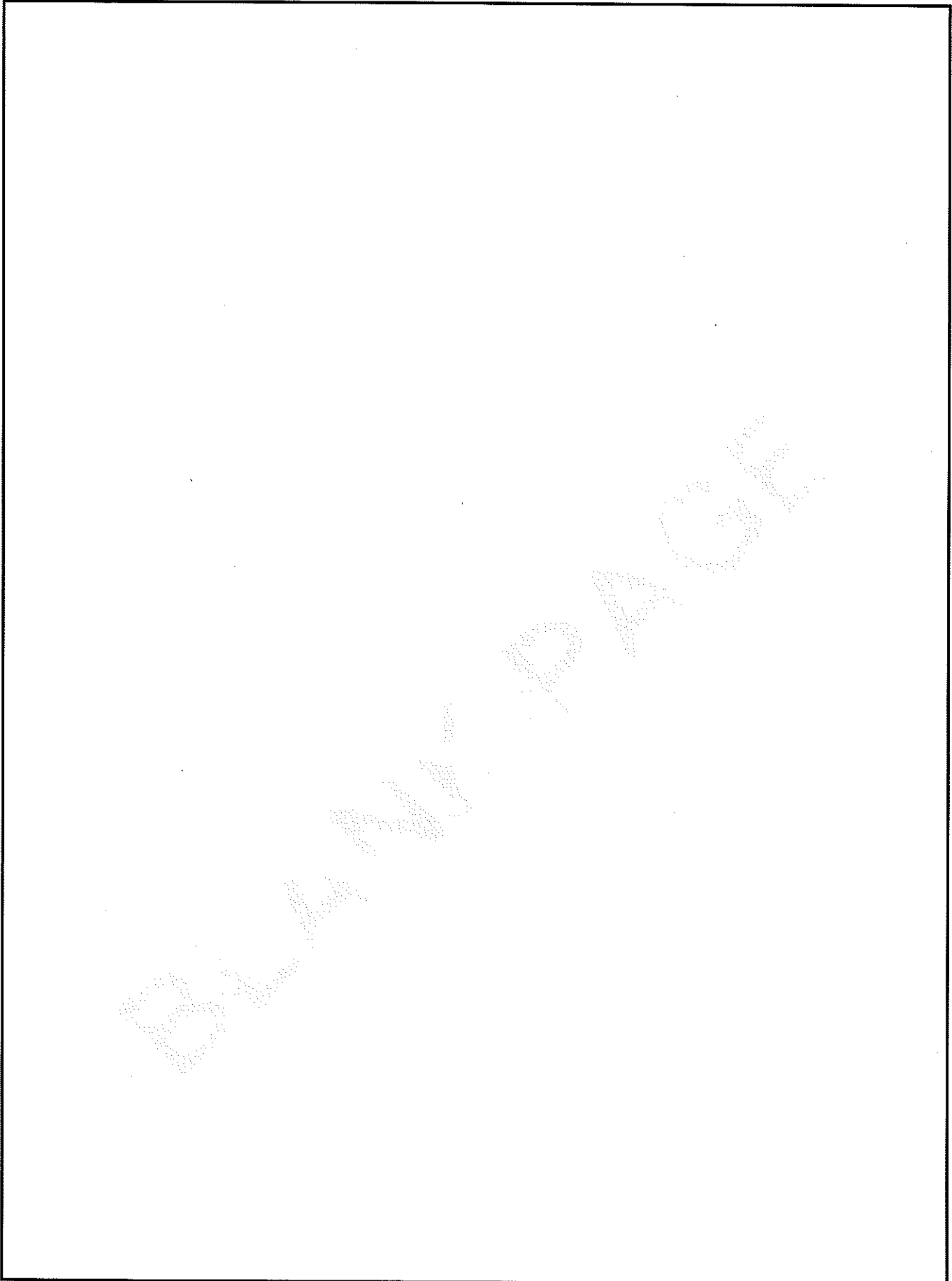

# Group 3

## Front carriage

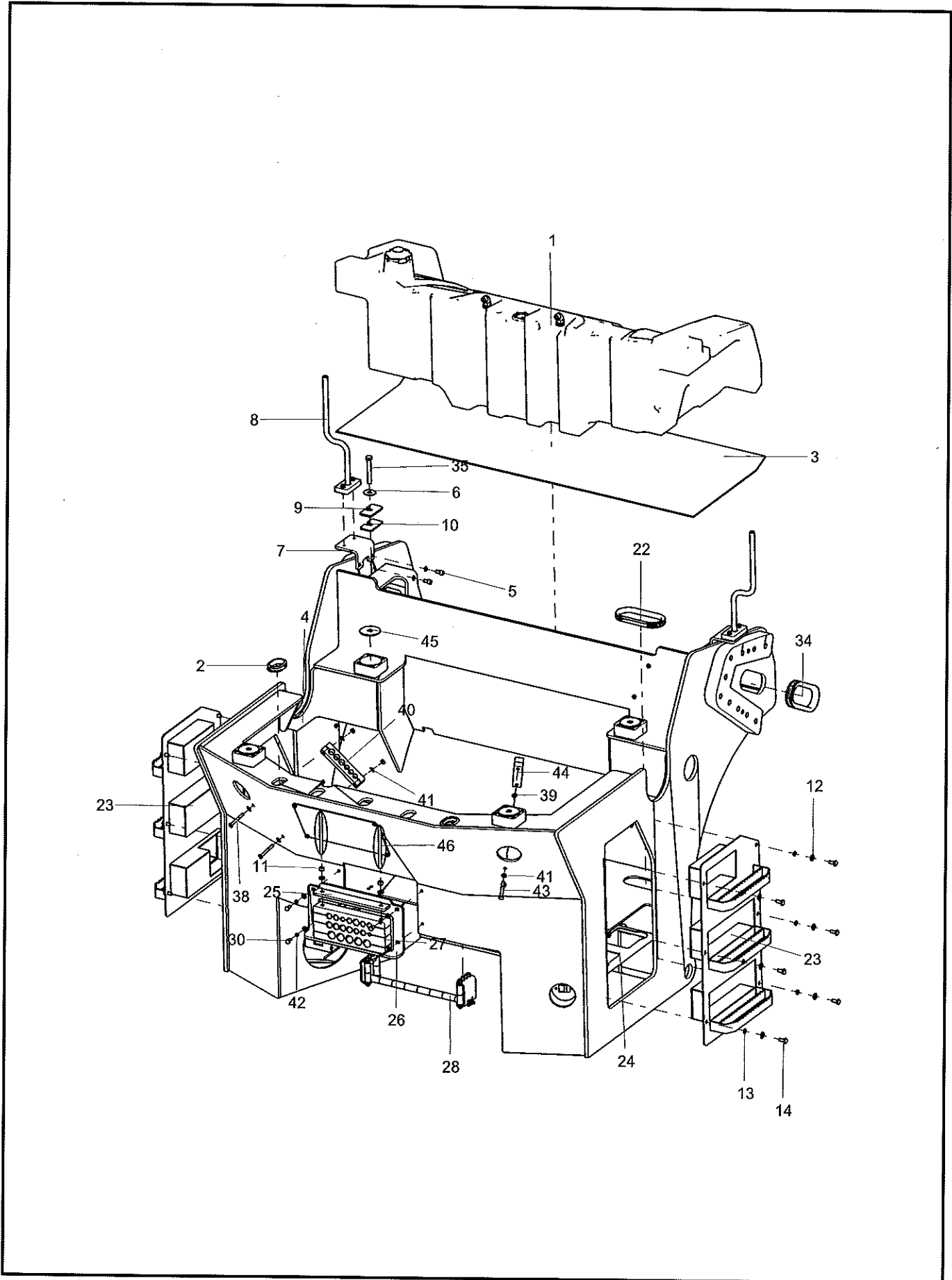



INDEX	PART NO.	DESCRIPTION	QTY	SEE PAGE
1	YLJ004954617	Diesel box assembly component	1	3-6
2	A820606030474	Protecting Ring	2	
3	YLJ007366684	Rubber tie-plate	1	
4	YLJ005417572	Front carriage weld assem.	1	
5	A210204000019	Screw	4	
6	A210404000008	Washer	2	
7	YLJ004687645	Mounting plate of rearview mirror braket	2	
8	YLJ004677594	Rearview mirror bracket	2	3-8
9	13449188	Pressure plate	2	
10	13449189	Rubber Cushion	2	
11	A210307000001	Nut	7	
12	A210405000001	Washer	14	
13	A210401000002	Washer	16	
14	A210111000037	Bolt	12	
17	YLJ004857847	The left stairs	1	
22	14130377	Rubber retainer (3)	4	
23	YLJ004857866	The right stairs	1	
24	13445924	Battery component	1	3-14
25	YLJ005427066	PLATE	1	
26	YLJ005426878	plate	1	
27	YLJ005338651	Clip	1	
28	13892932	Hose clip unit	1	3-16
30	A210111000011	Bolt	4	
33	A210405000007	Washer	8	
34	14523445	Rubber retainer	2	
35	A210111000364	Bolt	2	
38	A210111000307	Bolt	2	
39	A210307000017	Nut	4	
40	YLJ005336985	Clip	1	
41	A210405000011	Washer	12	
42	A210401000001	Washer	6	
43	A210110000218	Bolt	2	
44	YLJ005336947	Clip	1	
45	A820102010065	Adjusting Spacer	4	
46	YLJ005340419	bolt	2	

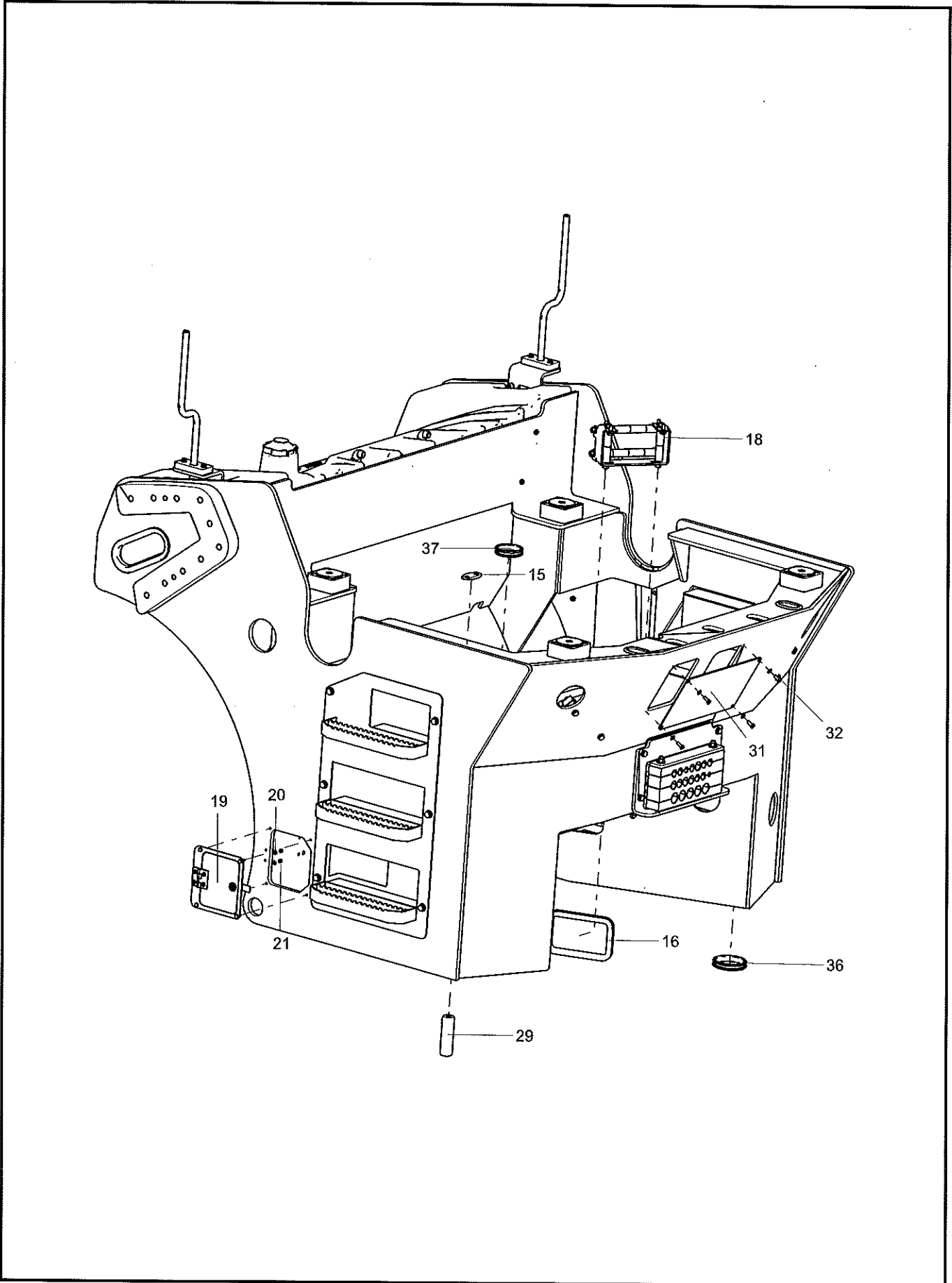

INDEX	PART NO.	DESCRIPTION	QTY	SEE PAGE
15	A820101339360	Guard	1	
16	13684348	Rubber retainer	2	
18	13685018	Hose clip unit	2	3-10
19	YLJ004895853	The Maintenance Door	1	3-12
20	A210405000006	Washer	2	
21	A210307000016	Nut	2	
29	A820301018783	Shaft, pin	1	
31	13686715	Cover plate	1	
32	A210111000089	Bolt	4	
36	YLJ005044599	ring	2	
37	14309087	Ring	1	

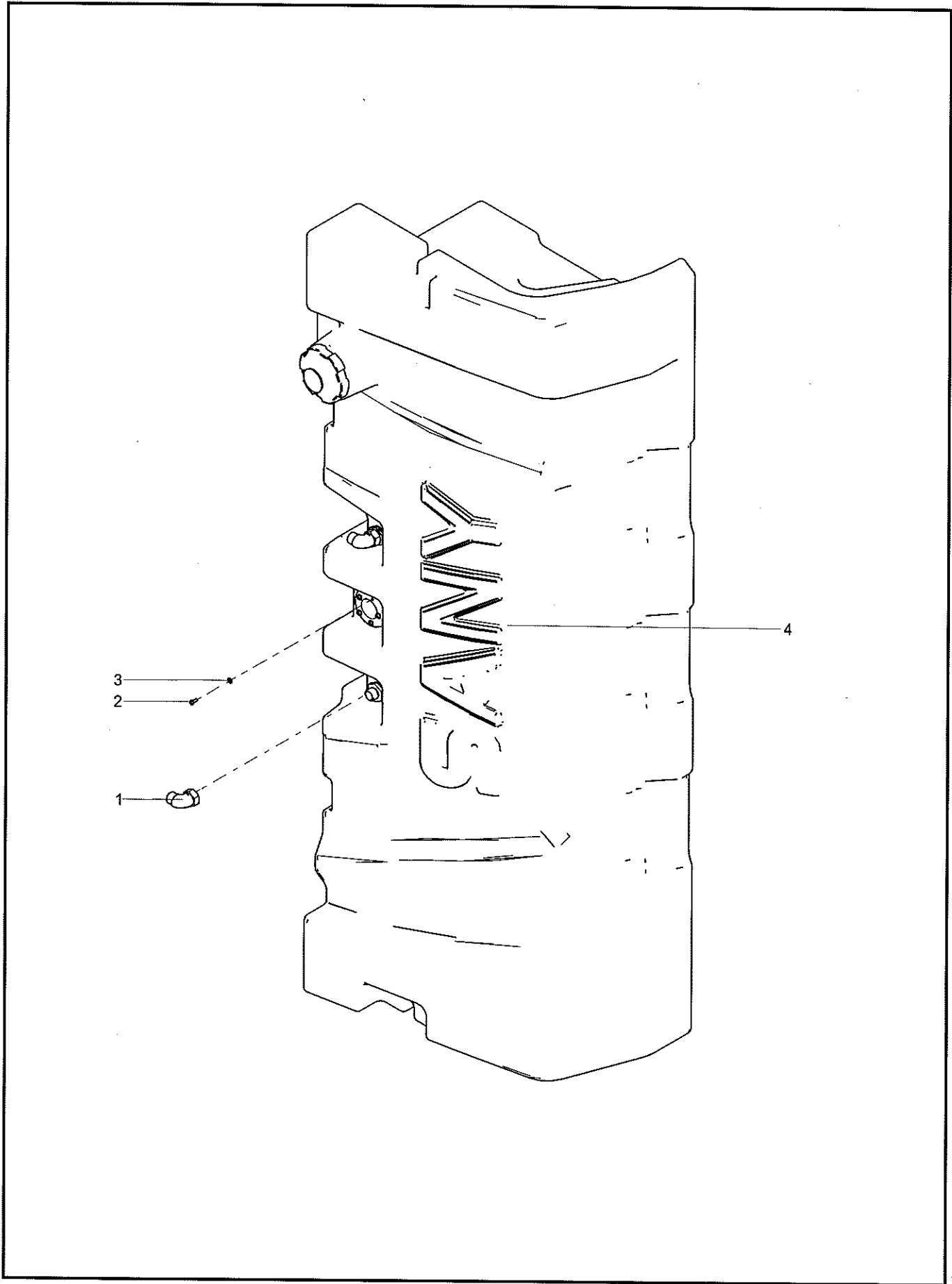

INDEX	PART NO.	DESCRIPTION	QTY	SEE PAGE
1	B21078000025	Elbow Fitting	2	
2	A21021000003	Screw	5	
3	A21040500005	Washer	5	
4	YLJ004797181	Oil	1	

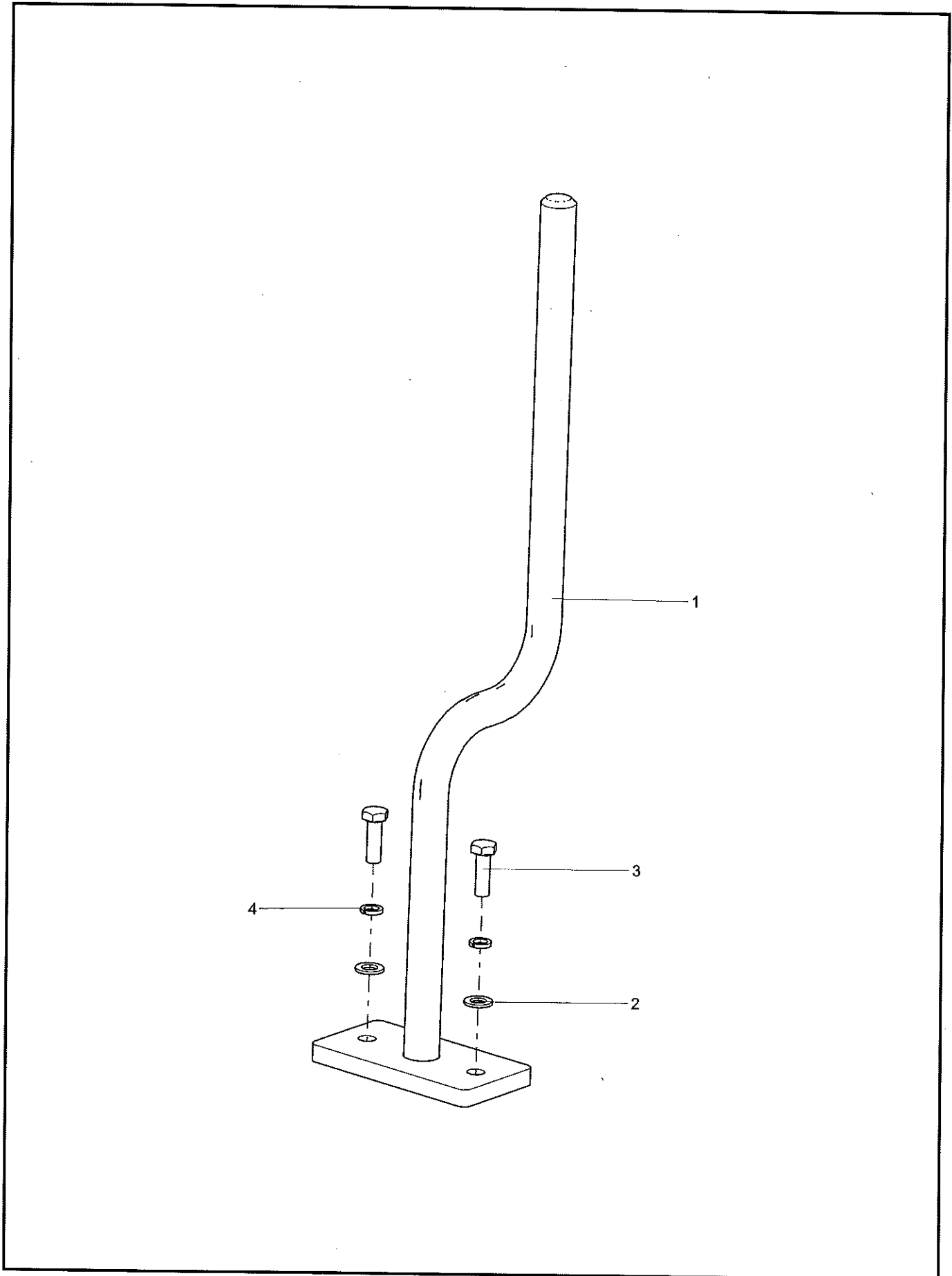

INDEX	PART NO.	DESCRIPTION	QTY	SEE PAGE
1	YLJ004677591	Rearview mirror bracket welding	1	
2	A210405000007	Washer	2	
3	A210111000092	Bolt	2	
4	A210401000017	Washer	2	

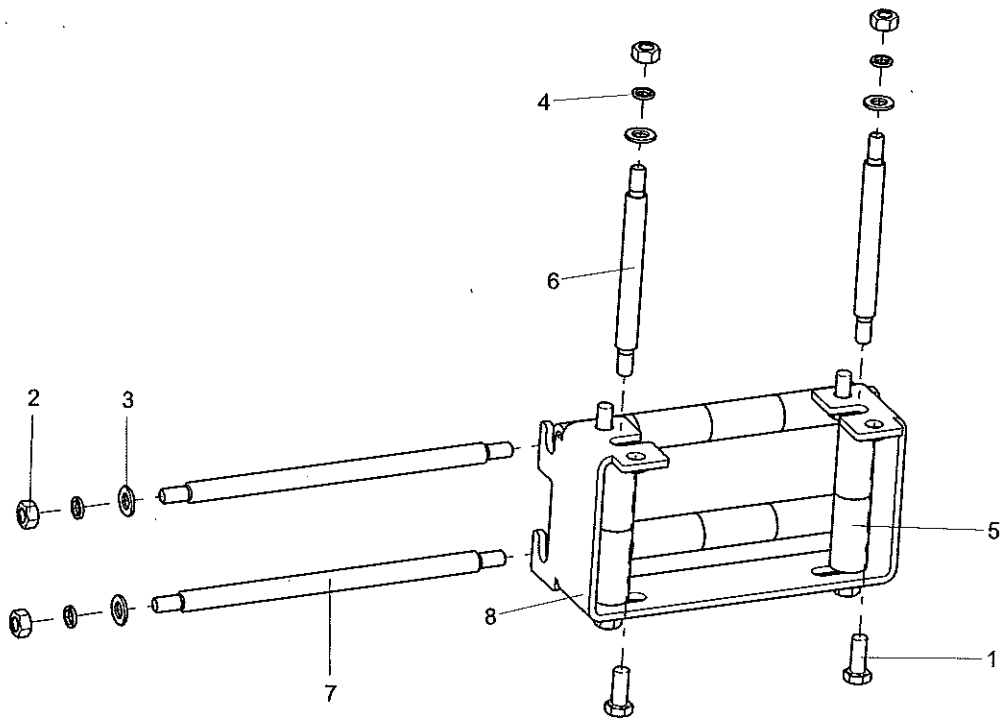



INDEX	PART NO.	DESCRIPTION	QTY	SEE PAGE
1	A210111000018	Bolt	4	
2	A210307000017	Nut	8	
3	A210405000011	Washer	12	
4	A210401000001	Washer	12	
5	13089922	Bushing	12	
6	13684351	Axle supporting	2	
7	13684352	Axle supporting	2	
8	13684350	Supporting plate	1	

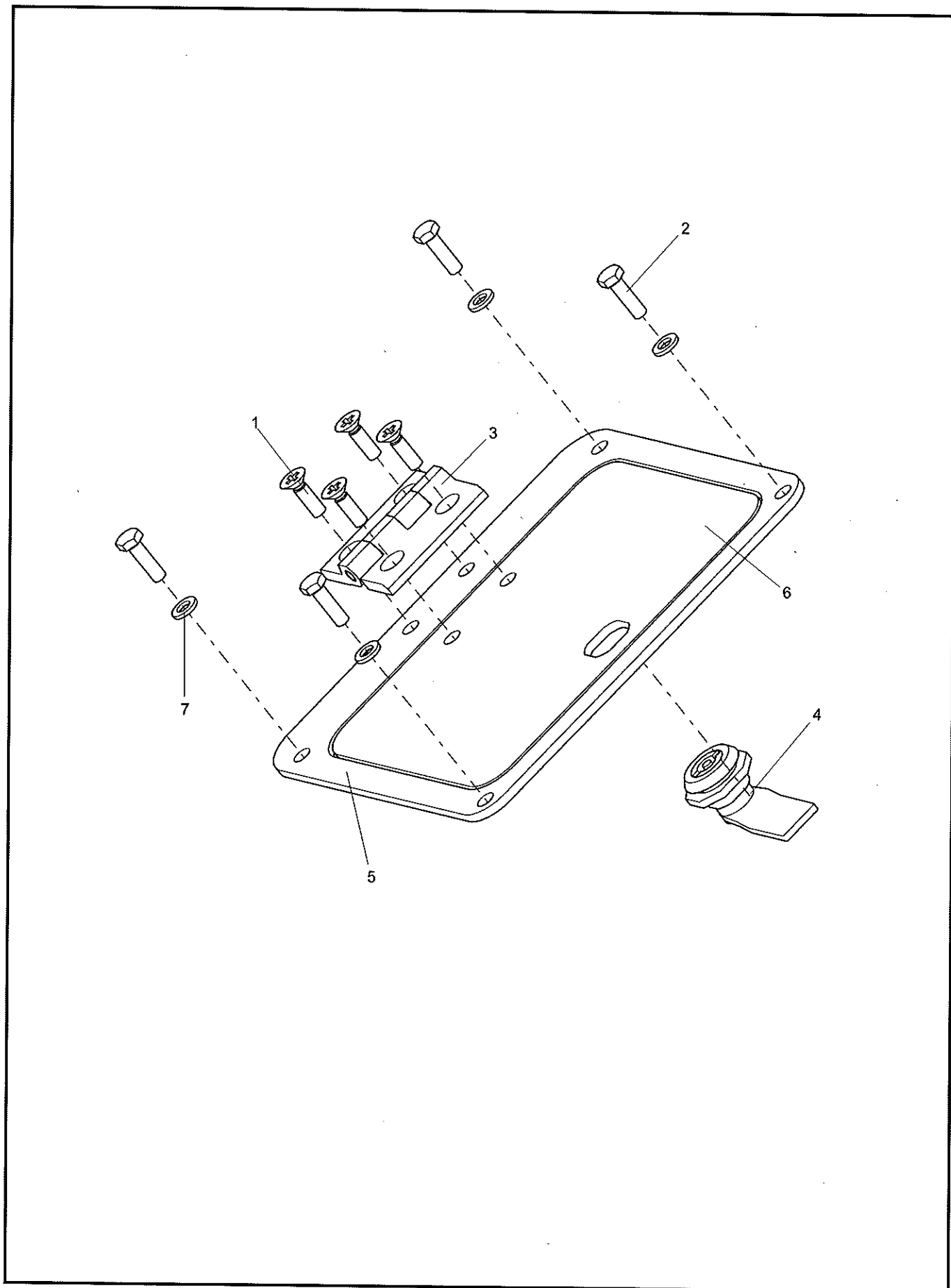

INDEX	PART NO.	DESCRIPTION	QTY	SEE PAGE
1	A210211000008	Screw	4	
2	A210111000080	Bolt	4	
3	60015644	Hinge	1	
4	A222200000058	Cover Latch Accessories	1	
5	YLJ004858317	The Mounting Door	1	
6	YLJ004895828	Door	1	
7	A210405000006	Washer	4	

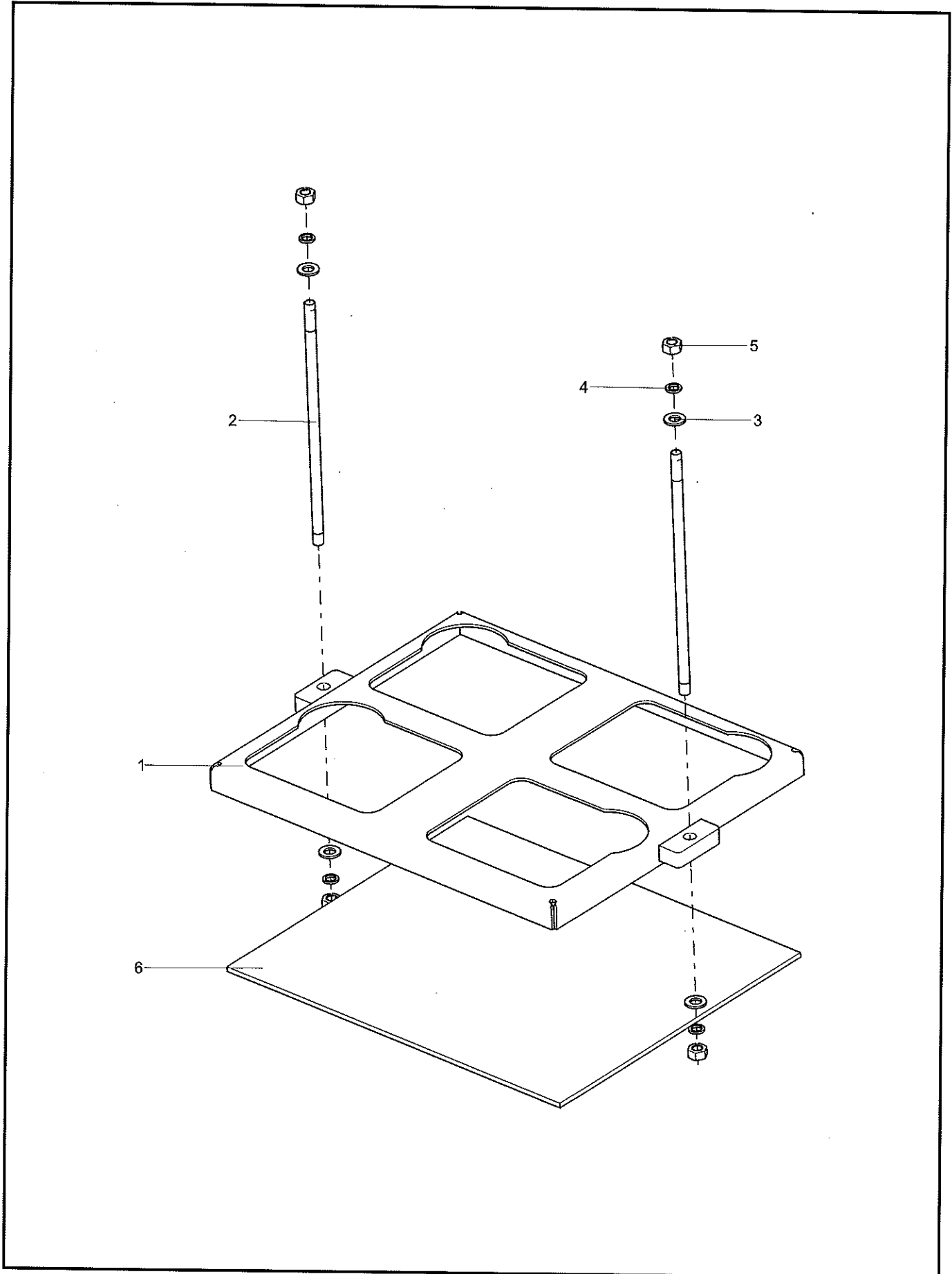

INDEX	PART NO.	DESCRIPTION	QTY	SEE PAGE
1	13445919	Battery cover assembly	1	
2	14159223	Screw	2	
3	A210405000011	Washer	4	
4	A210401000001	Washer	4	
5	A210307000017	Nut	4	
6	13445921	Rubber liner plates	1	

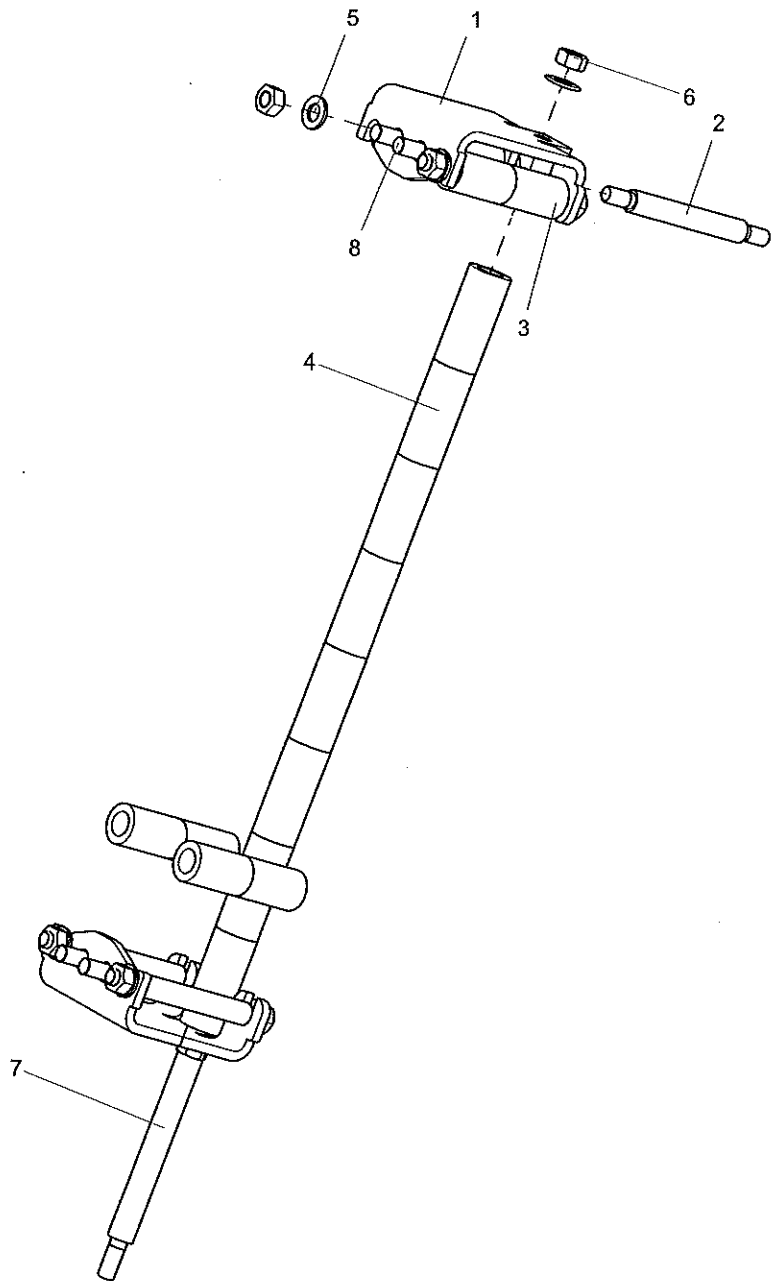

INDEX	PART NO.	DESCRIPTION	QTY	SEE PAGE
1	13892899	Supporting plate	2	
2	13836405	Axle supporting	4	
3	13836428	Bushing	8	
4	13892906	Bushing	8	
5	A210405000011	Washer	14	
6	A210307000017	Nut	10	
7	12844740	Support shaft	1	
8	A210204000161	Screw	4	

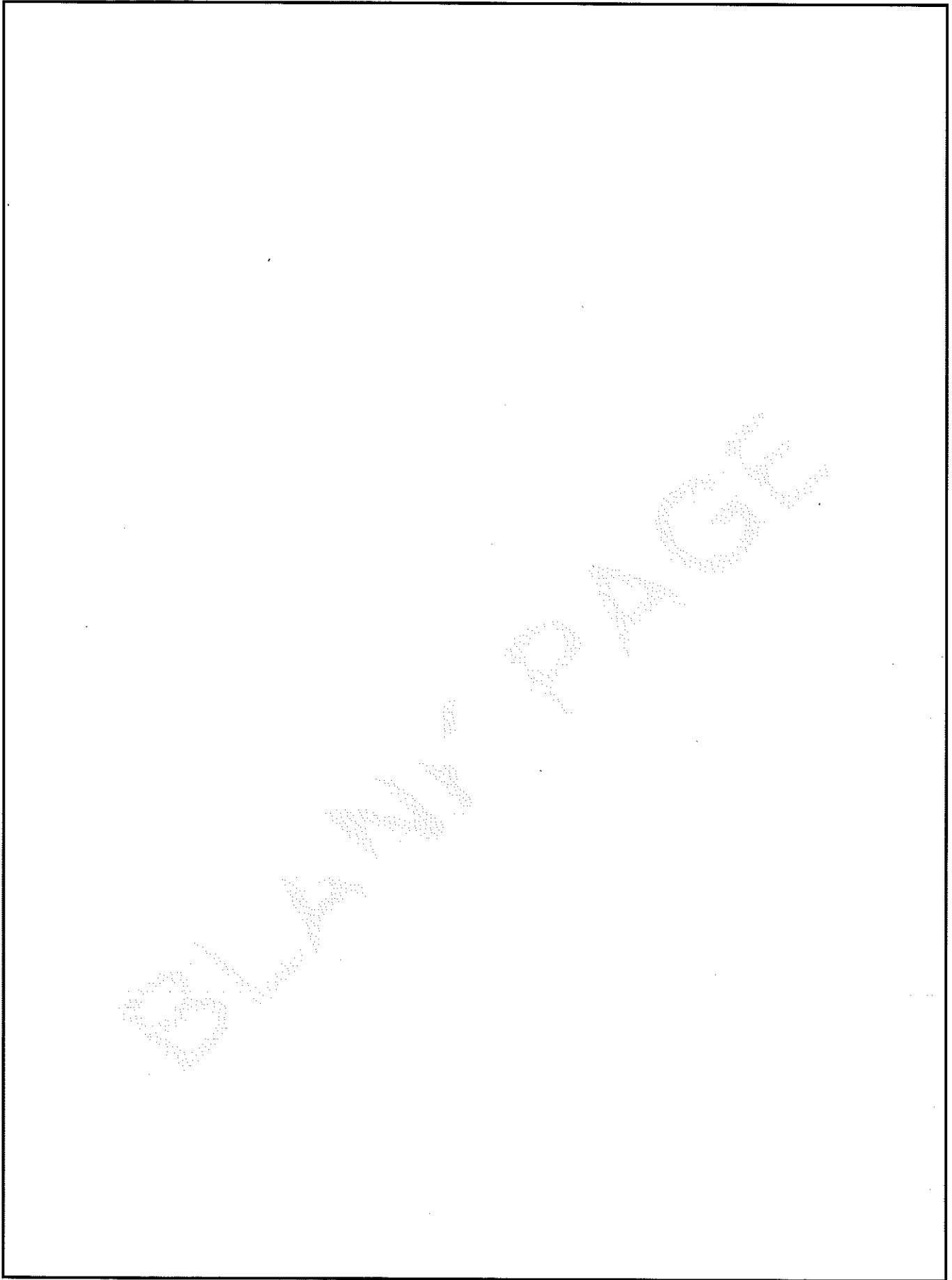



# Group 4

## controlling system assembly

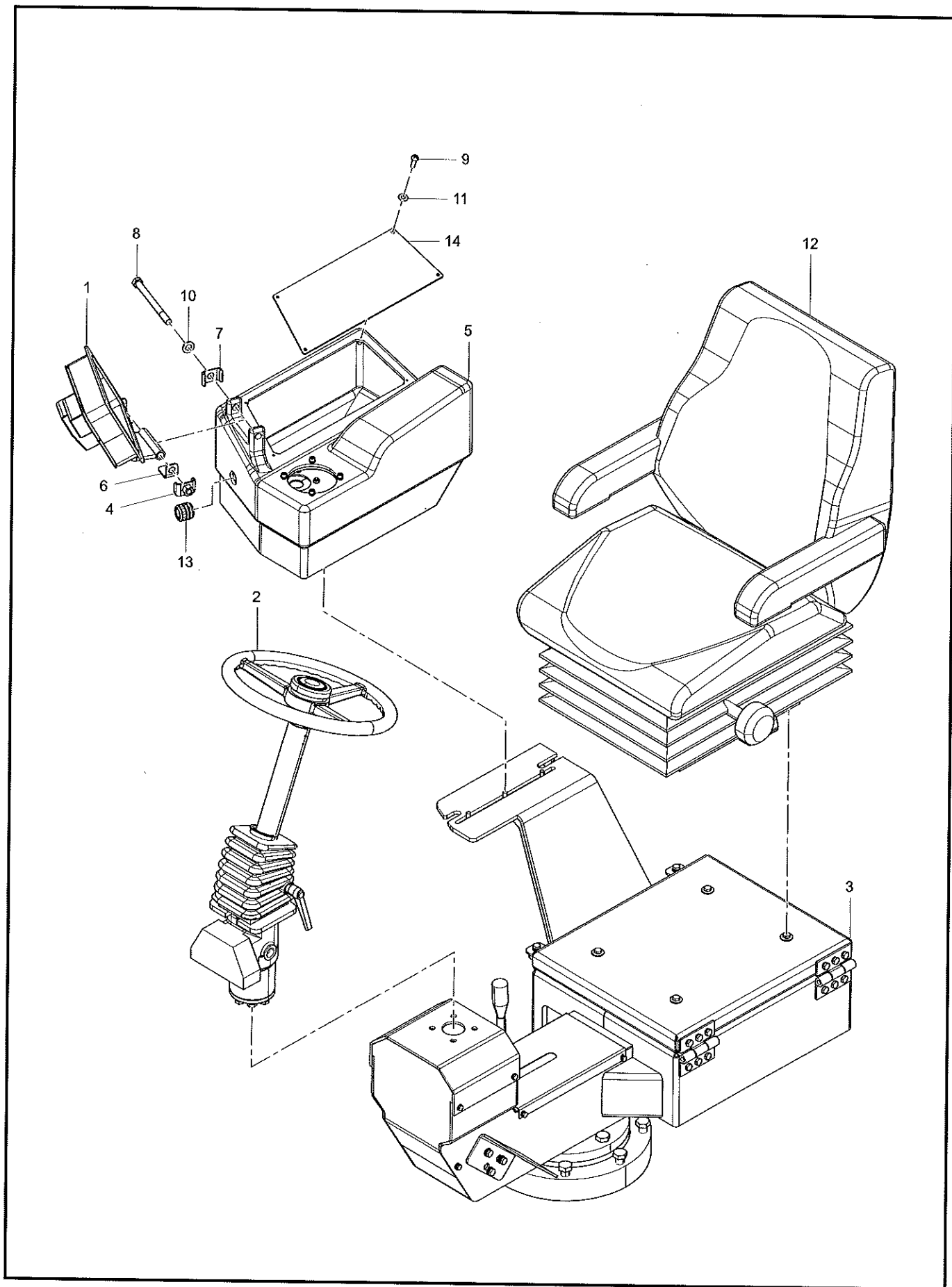

INDEX	PART NO.	DESCRIPTION	QTY	SEE PAGE
1	13352079	Display Mounting Rack	1	4-4
2	14155306	Steering Control System	1	4-6
3	14352067	Console bracket assembly	1	4-8
4	14463848	U plate	1	
5	YLJ004680731	side box	1	4-14
6	14463742	L-shape plate	2	
7	14464030	U plate	1	
8	A210110000006	Bolt	1	
9	A210210000030	Screw	4	
10	A210405000001	Washer	1	
11	A210405000004	Washer	4	
12	A229900001929	Mechanical Suspension Driver seat	1	
13	A249900000600	Cable Connector	1	
14	YLJ006552828	plate	1	

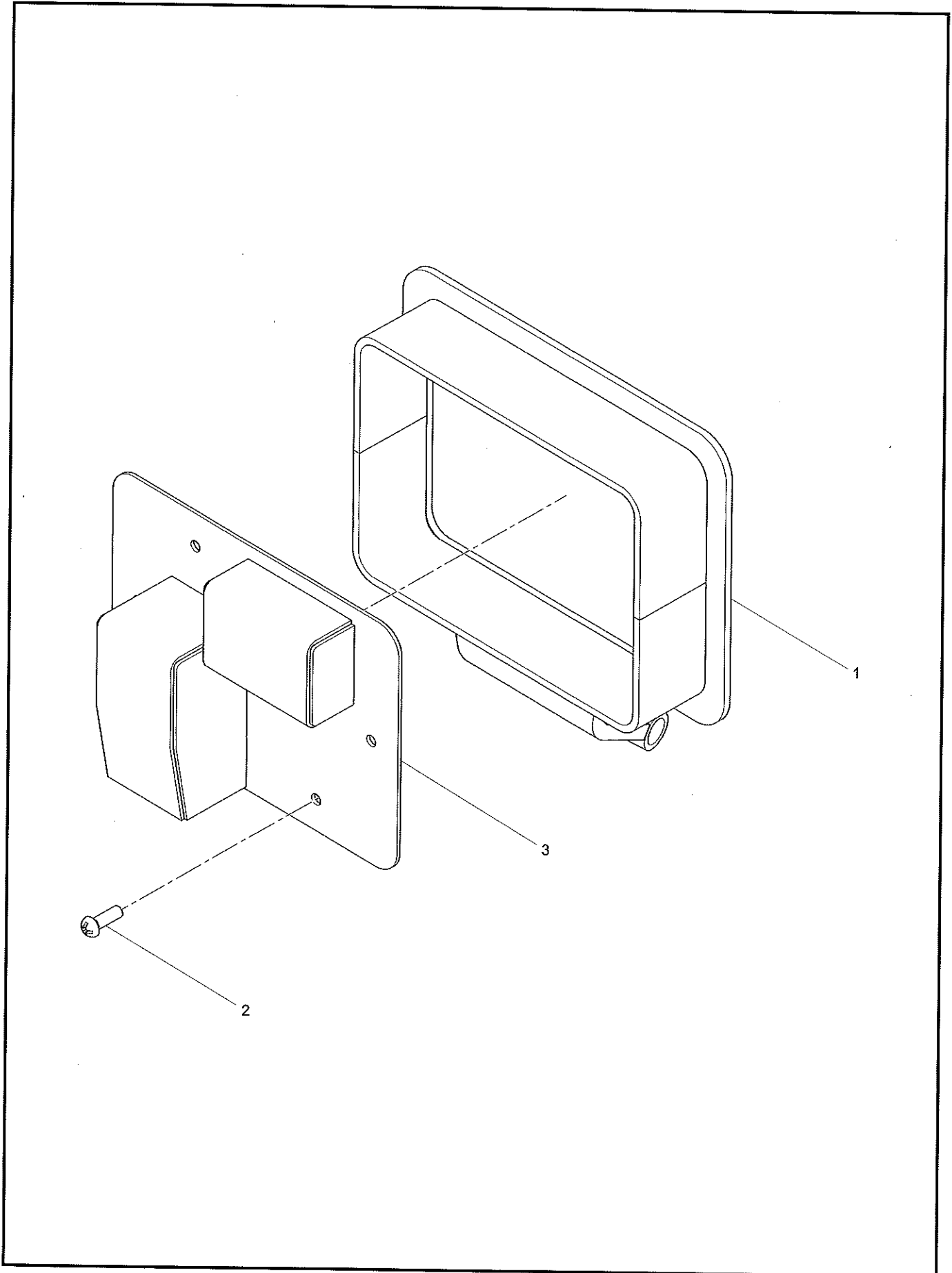

INDEX	PART NO.	DESCRIPTION	QTY	SEE PAGE
1	13352058	Mounting Rack Welding	1	
2	A210210000030	Screw	4	
3	YLJ004776713	Rear Cover Welding	1	

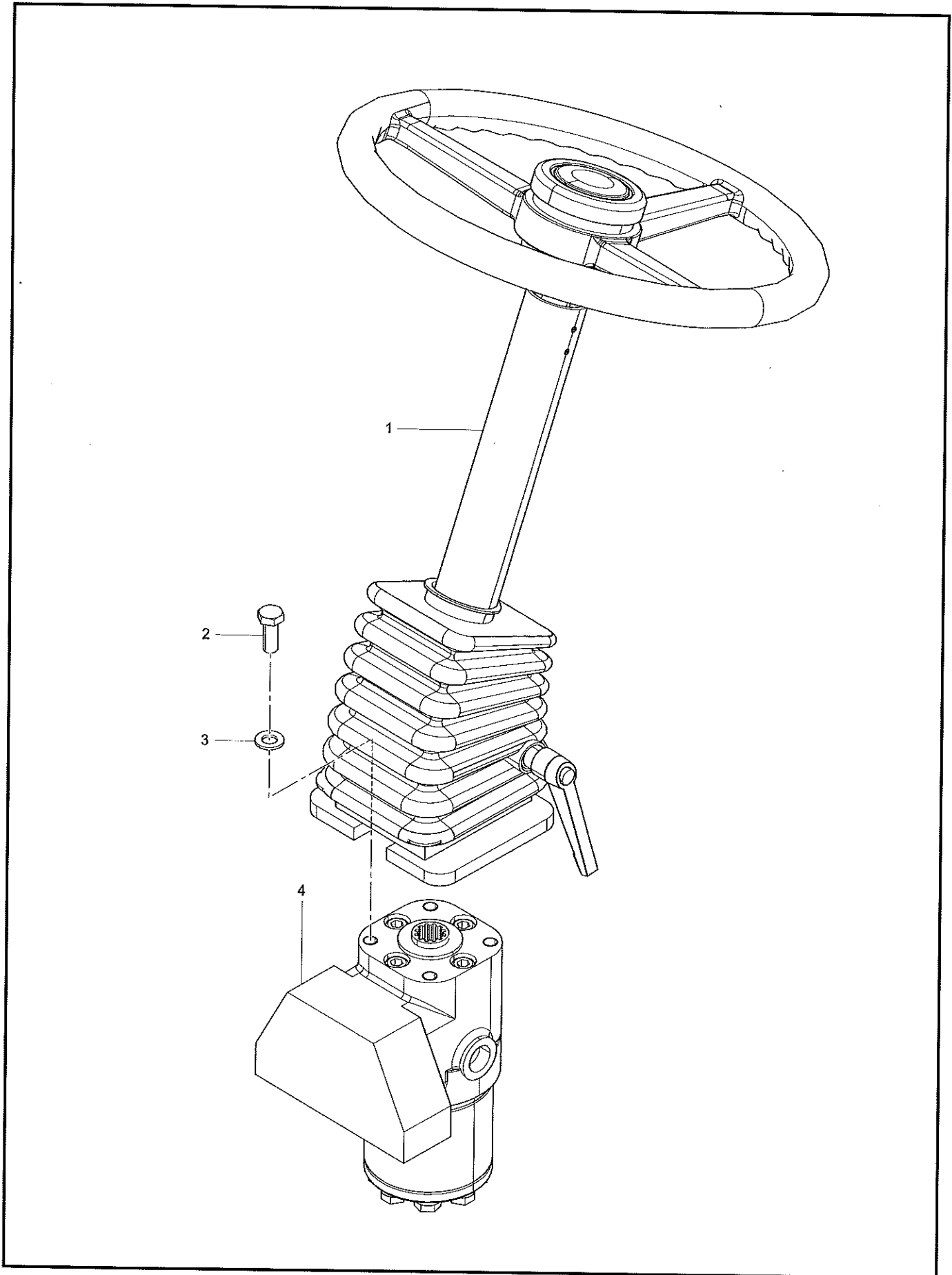

INDEX	PART NO.	DESCRIPTION	QTY	SEE PAGE
1	61010743	Instrument panel assembly	1	
2	A210111000018	Bolt	3	
3	A210405000011	Washer	3	
4	A229900002460	Steering Gear	1	

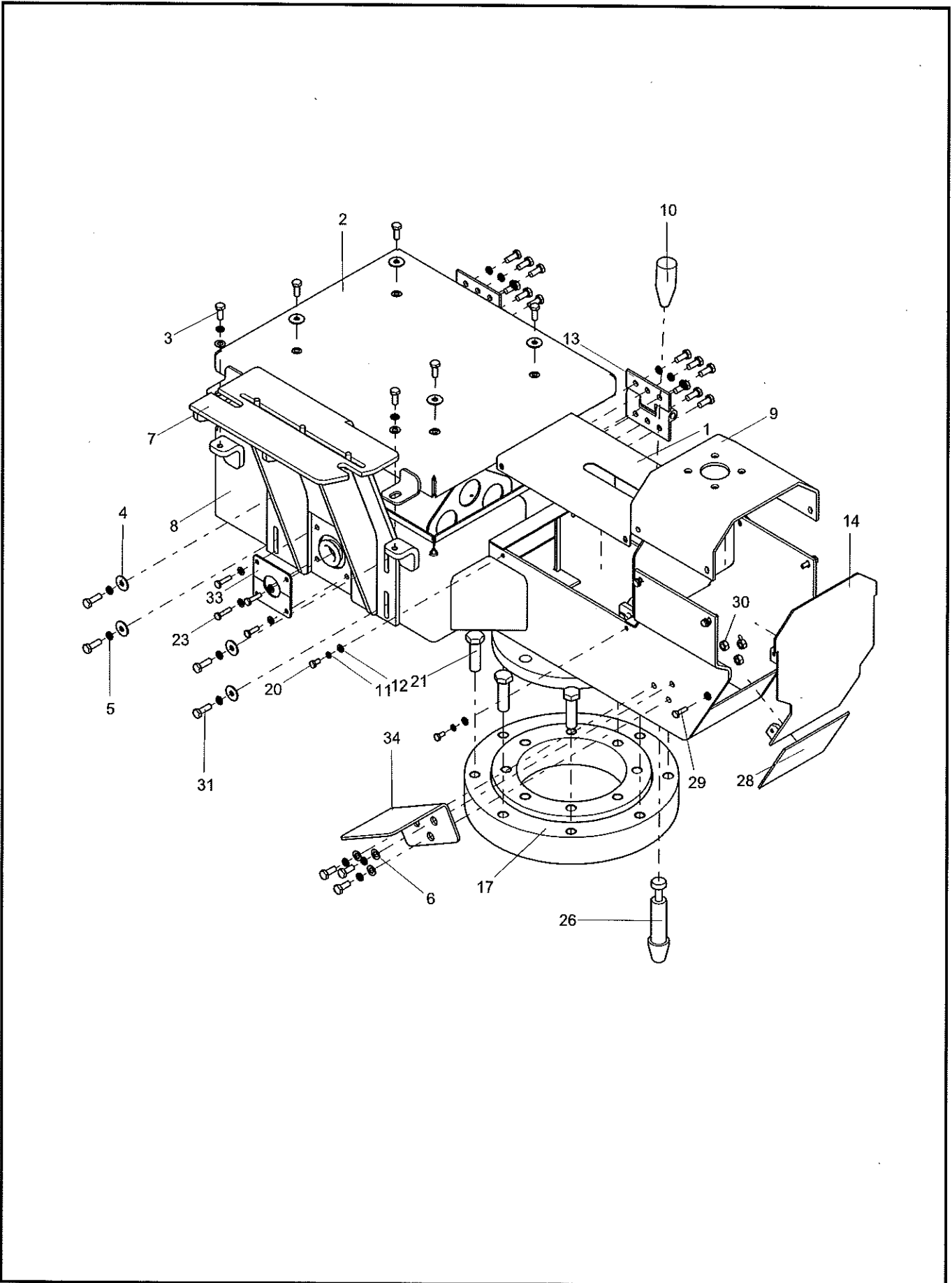



INDEX	PART NO.	DESCRIPTION	QTY	SEE PAGE
1	13731104	Bracket uppercover board	1	
2	13688857	Upper cover welding of control cabinet	1	
3	A210111000089	Bolt	29	
4	A210404000005	Washer	11	
5	A210401000017	Washer	29	
6	A210405000007	Washer	14	
7	14517625	Side box support plate welding	1	
8	14485553	Console bracket weldment	1	
9	14242649	Steering board weldedment	1	
10	A219900000089	Handle Ball	1	
11	A210401000016	Washer	16	
12	A210405000006	Washer	14	
13	A210891000007	Hinge	2	
14	14519482	Front cover plate weldment	1	
17	A229900003184	Slewing bearings	1	
20	A210111000078	Bolt	6	
21	A210111000283	Bolt	12	
23	A210111000081	Bolt	5	
26	10211702	Coupling bar	1	
28	14155632	Rubber pad	1	
29	A210111000080	Bolt	3	
30	A210307000012	Nut	6	
31	A210111000090	Bolt	4	
33	14354664	Lock plate	4	
34	13394536	Foot pedal	2	

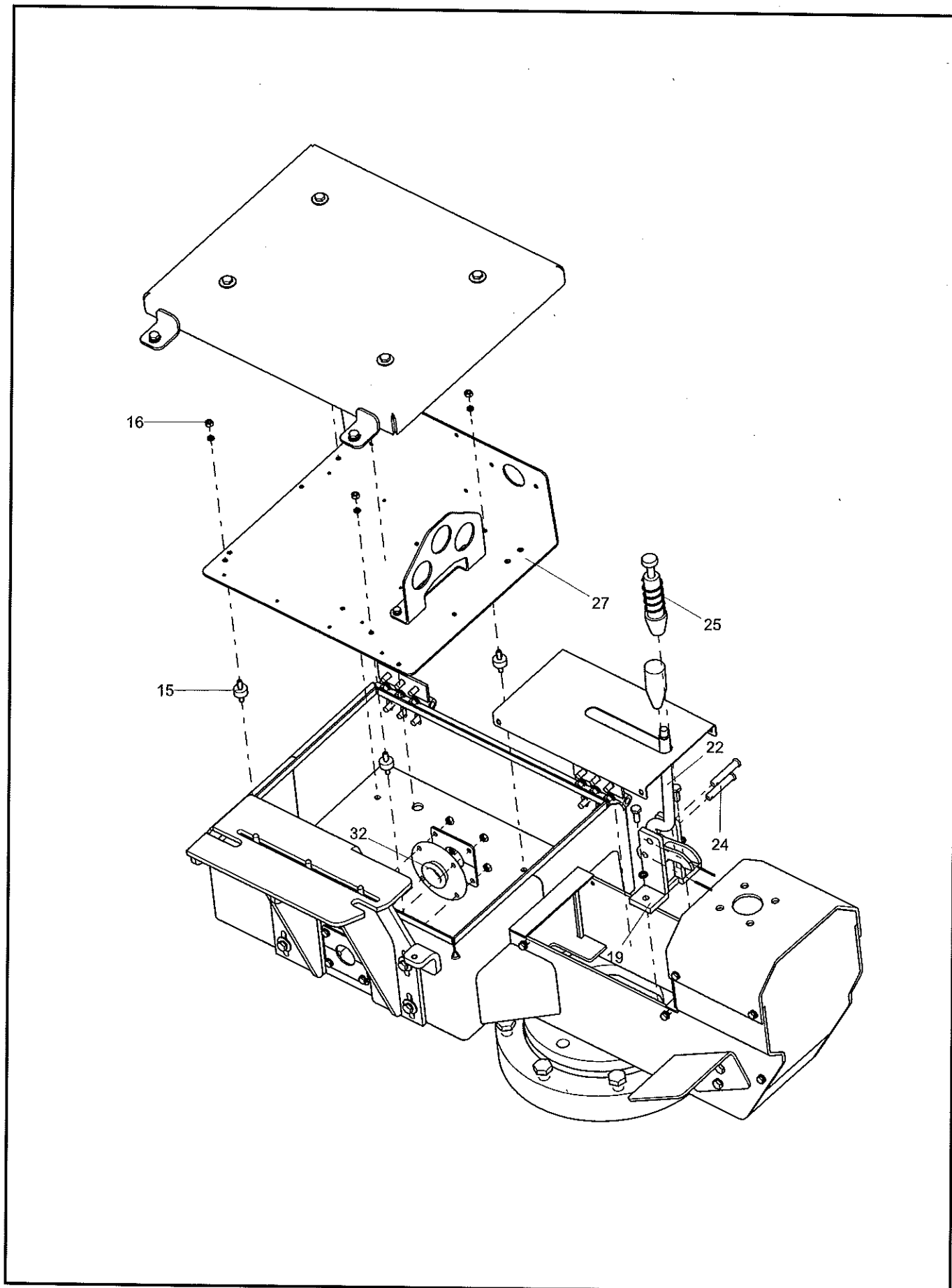

INDEX	PART NO.	DESCRIPTION	QTY	SEE PAGE
15	A222000000080	Damper	4	
16	A210307000016	Nut	12	
18	A210501000043	Pin	2	
19	10212192	Support welding	1	
22	13610941	Rock Arm	1	
24	A210508000067	Pin	2	
25	A210616000012	Spring	1	
27	13175451	Electrical control penal component	1	4-12
32	14354634	Sealing ring	1	

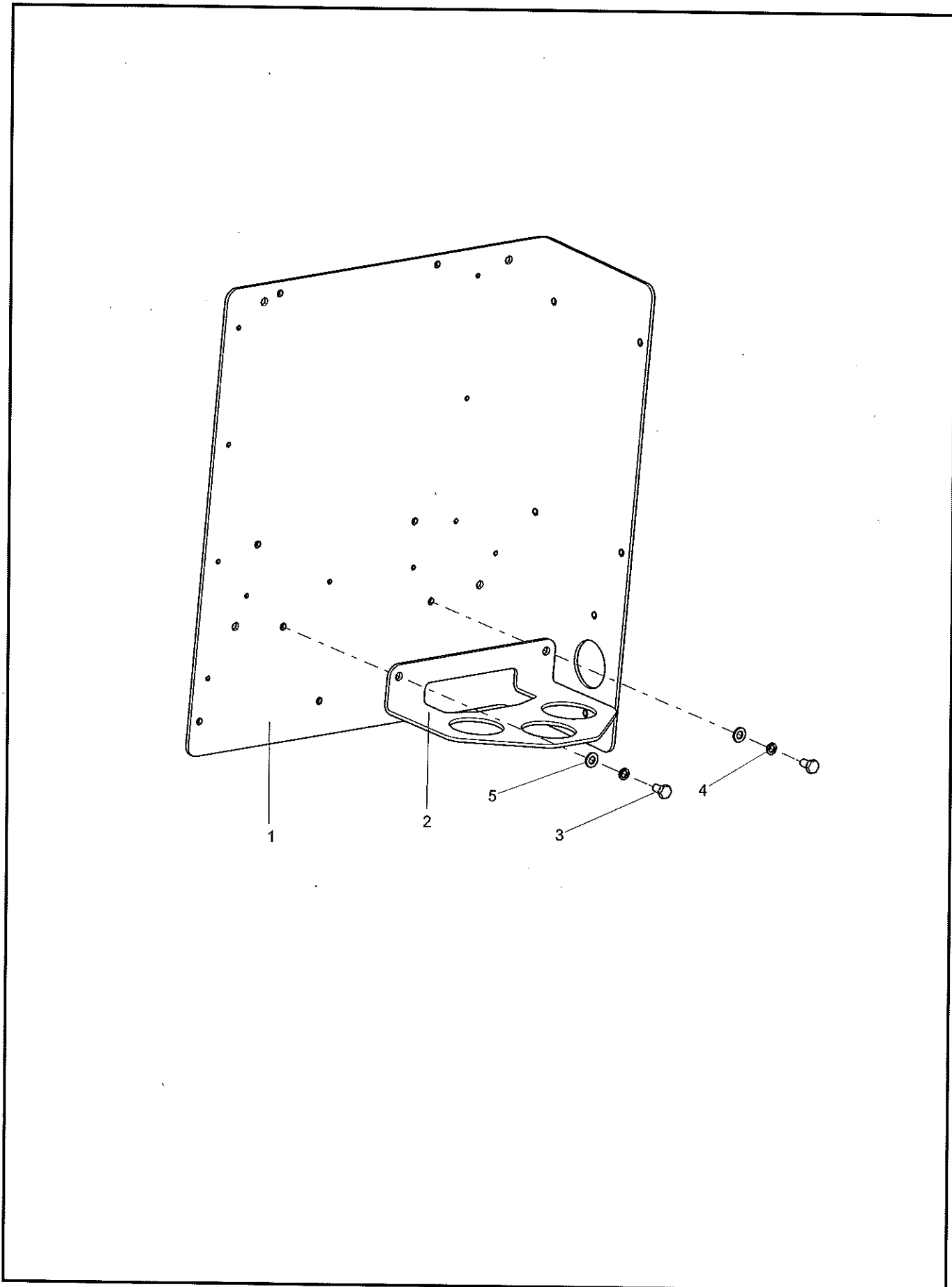

INDEX	PART NO.	DESCRIPTION	QTY	SEE PAGE
1	13175440	Electrical control penal	1	
2	13175443	Fixing plate	1	
3	21005327	Bolt	2	
4	A210401000016	Washer	2	
5	A210405000006	Washer	2	

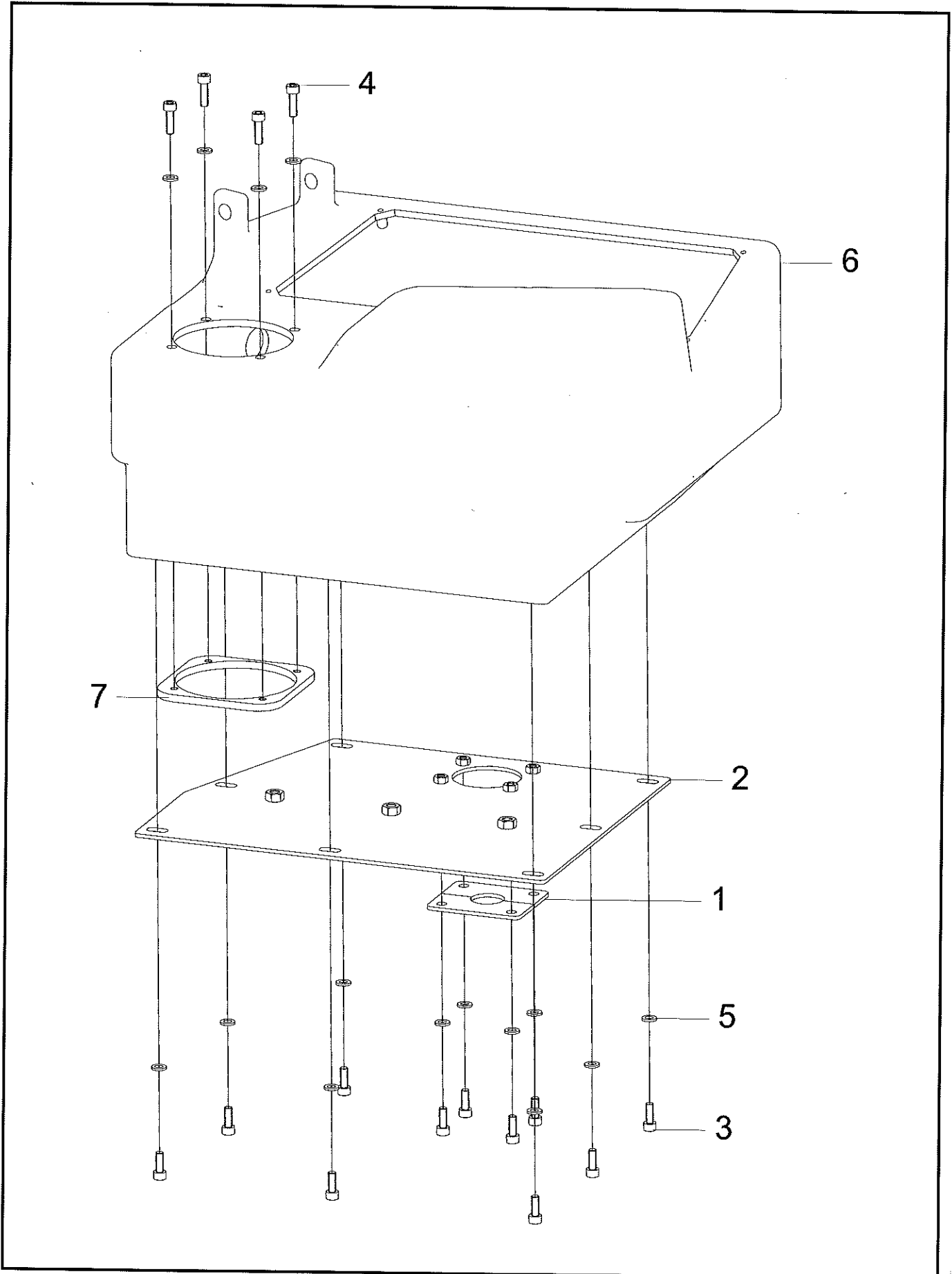

INDEX	PART NO.	DESCRIPTION	QTY	SEE PAGE
1	14353444	Harness installation plate	2	
2	14353567	Side box base plate	1	
3	A210204000130	Screw	11	
4	A210204000131	Screw	4	
5	A210405000006	Washer	15	
6	YLJ004680167	Deputy box manipulation	1	
7	YLJ004680723	plate	1	

BLANK PAGE



Group 5

air

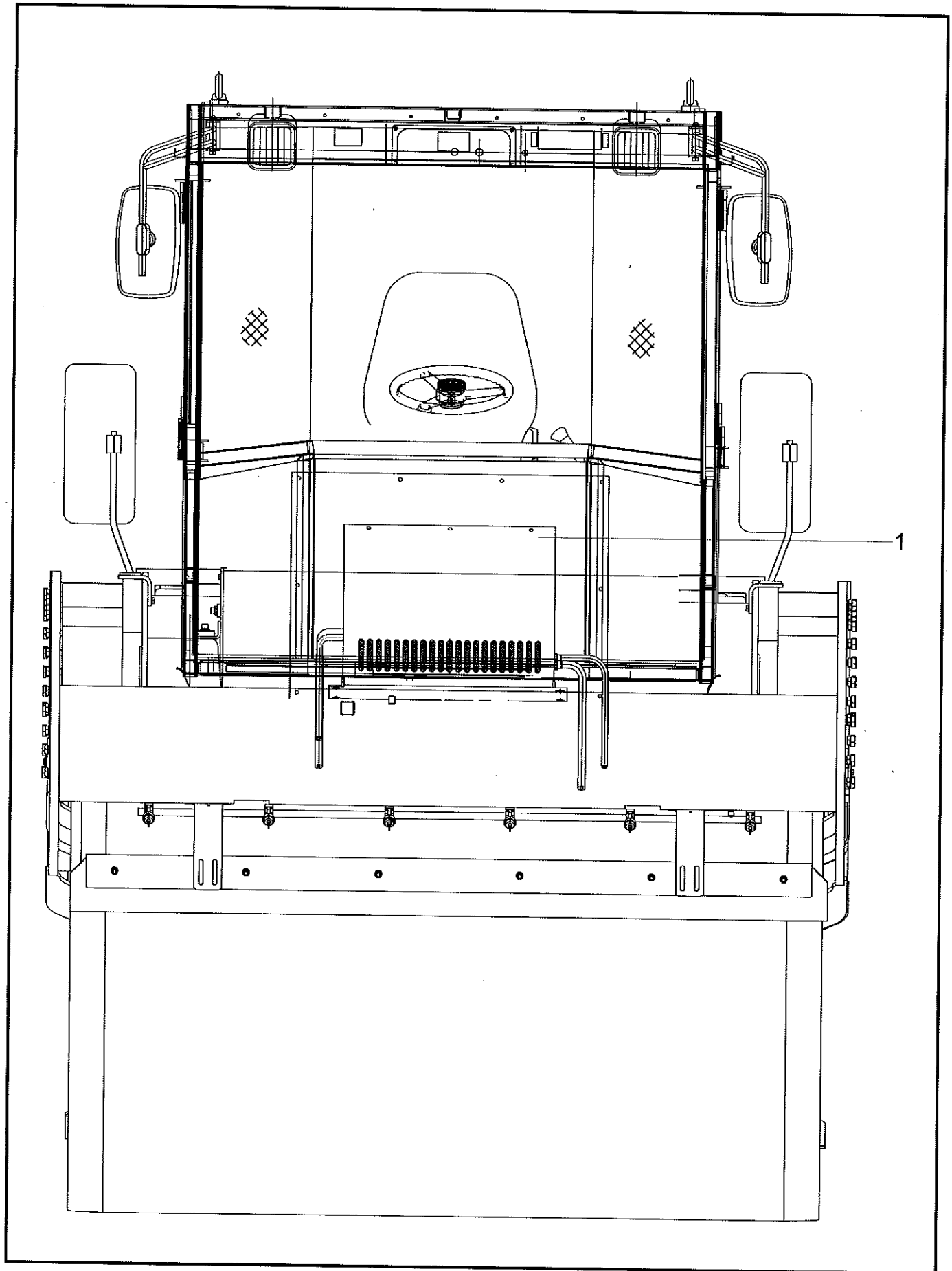

INDEX	PART NO.	DESCRIPTION	QTY	SEE PAGE
1	61030482	Double Drum Vibratory Roller Air-condition Assy	1	

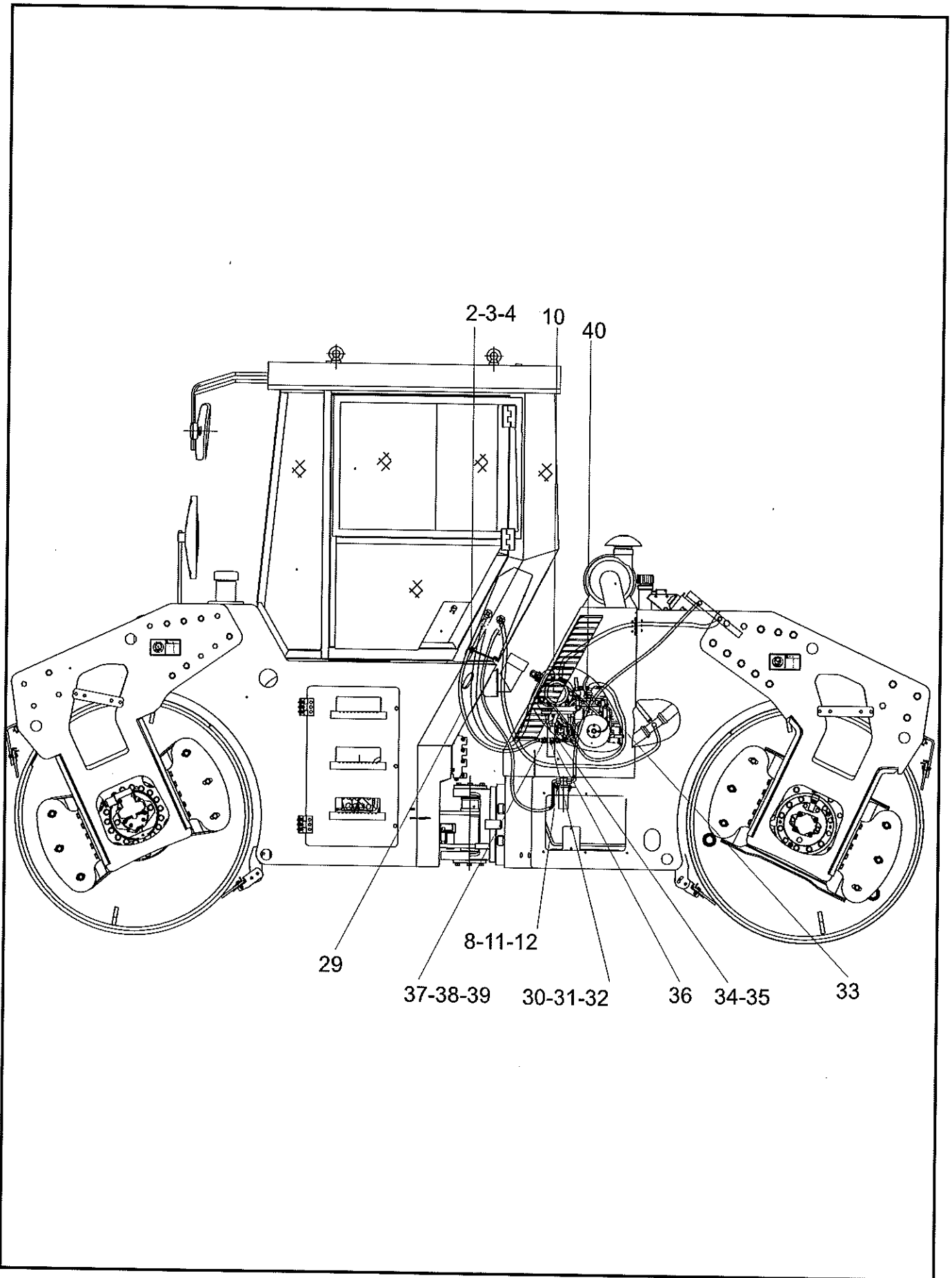

INDEX	PART NO.	DESCRIPTION	QTY	SEE PAGE
2	A210111000018	Bolt	4	
3	A210401000001	Washer	13	
4	A210404000003	Washer	4	
8	A210405000006	Washer	4	
10	11026326	Compressor bracket	1	
11	A210111000078	Bolt	4	
12	A210307000016	Nut	4	
29	60253934	Rubber Hose	1	
30	A220400000070	Ball Valve	1	
31	A820301012683	Screw Rod, U-type	2	
32	A210401000016	Washer	4	
33	A820205001582	Fitting	2	
34	A210855000066	Hole-type Hose Clamp	6	
35	60200724	Fastening Clamp	4	
36	11534382	Rubber pad	1	
37	10993801	Connector	1	
38	A229900001355	Bibow	1	
39	10993805	Connector	3	
40	120701080001A	Type A Triangular Belt	1	

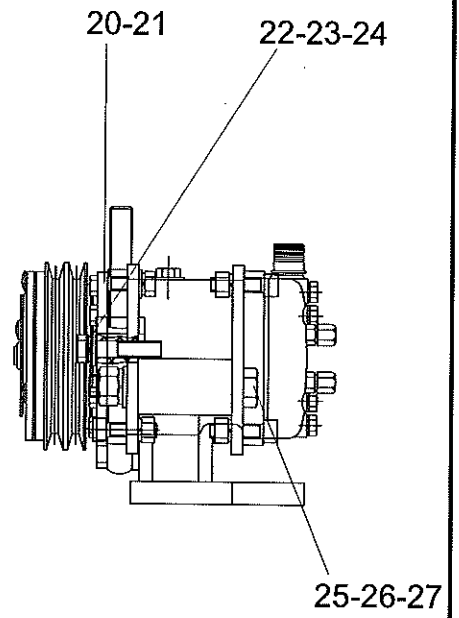
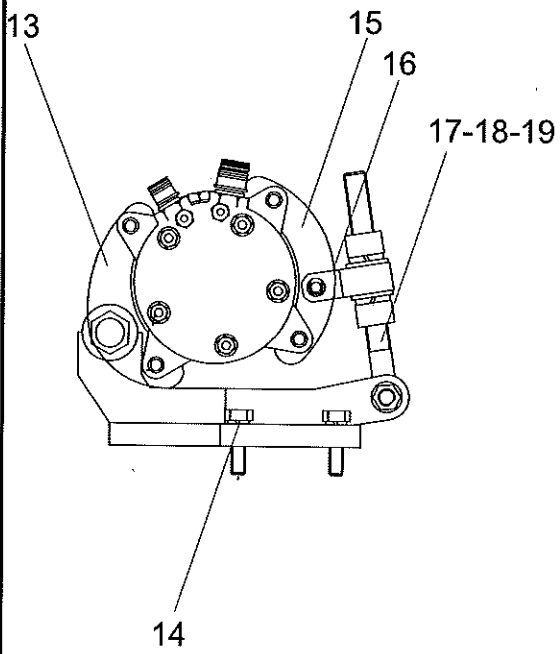

INDEX	PART NO.	DESCRIPTION	QTY	SEE PAGE
13	A820101319357	Crescent Shaped Plate	2	
14	A210111000026	Bolt	3	
15	A820101320930	Bent Plate	1	
16	A820101348563	Adjusting Block	1	
17	A210307000040	Nut	2	
18	A210401000004	Washer	2	
19	A820301014728	Bolt, Hinged	1	
20	A210204000197	Screw	6	
21	A210307000017	Nut	6	
22	A210111000119	Bolt	1	
23	A210405000001	Washer	1	
24	A210401000002	Washer	1	
25	A210110000304	Bolt	1	
26	A210401000006	Washer	1	
27	A210307000029	Nut	1	

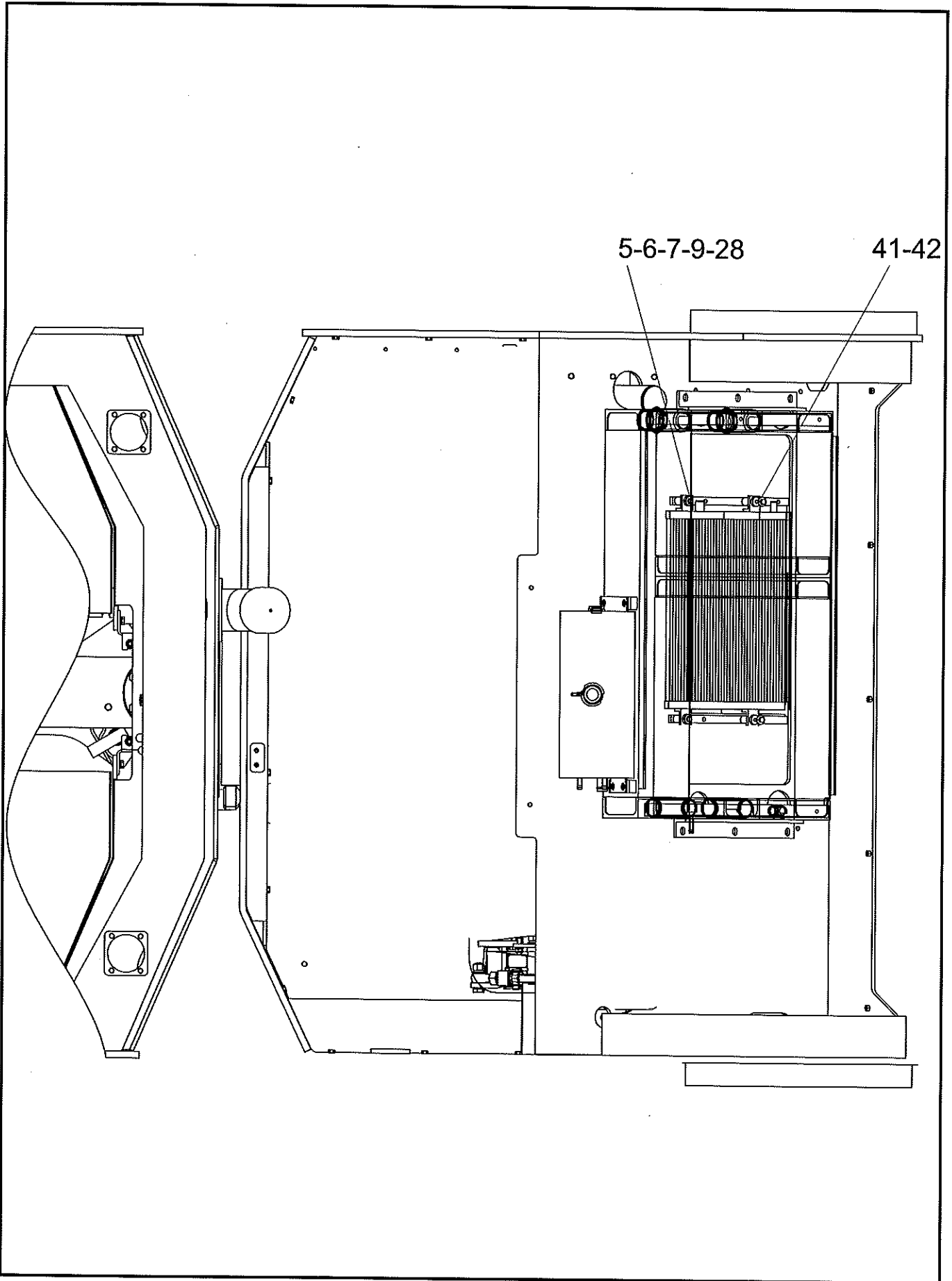



INDEX	PART NO.	DESCRIPTION	QTY	SEE PAGE
5	21005351	Bolt	4	
6	A210401000017	Washer	8	
7	A210405000007	Washer	8	
9	A210111000090	Bolt	4	
28	14071075	cylinder	4	
41	14495199	Right plate	1	
42	14495244	Left plate	1	

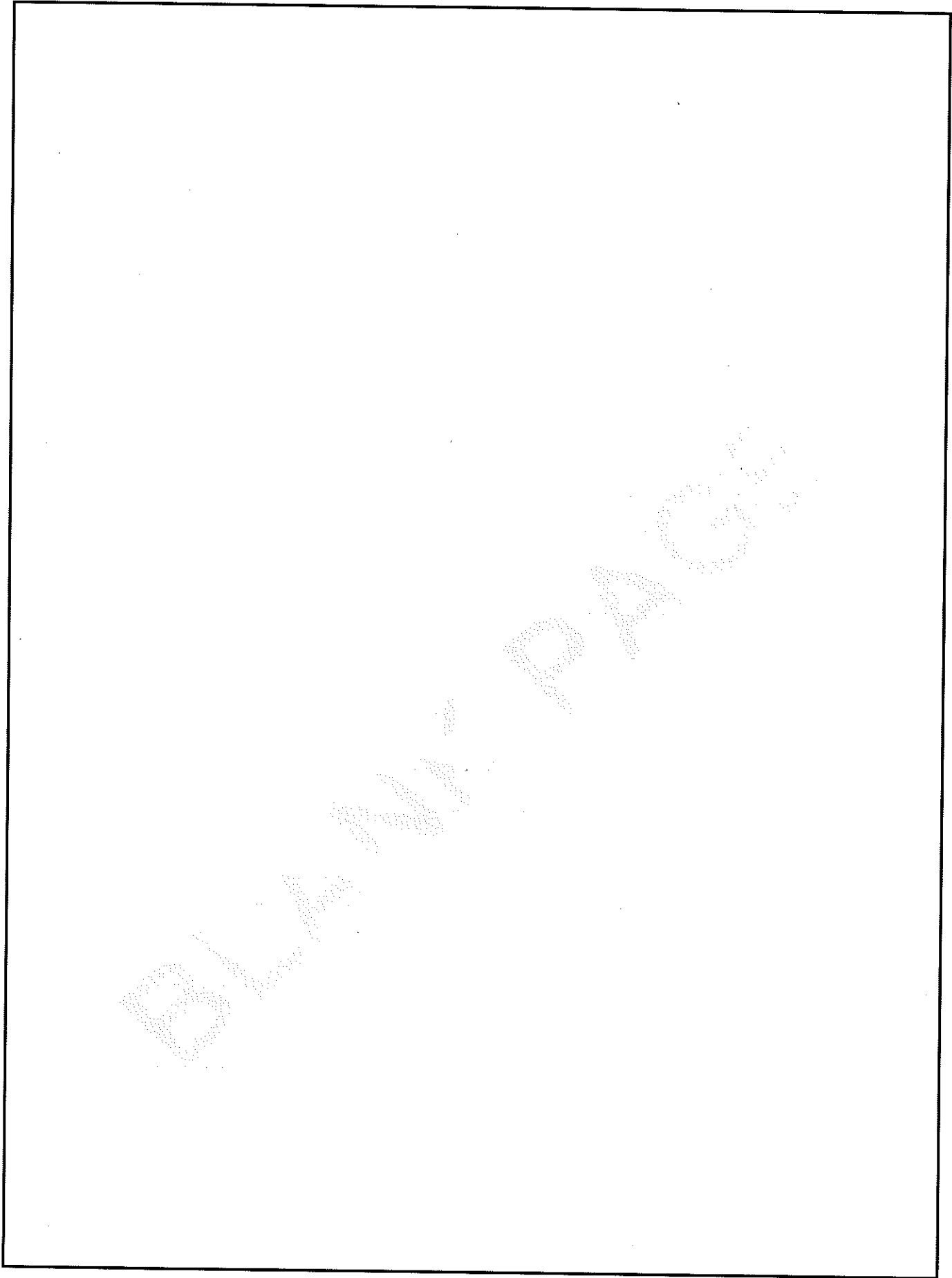

# Group 6

## Center hinge frame

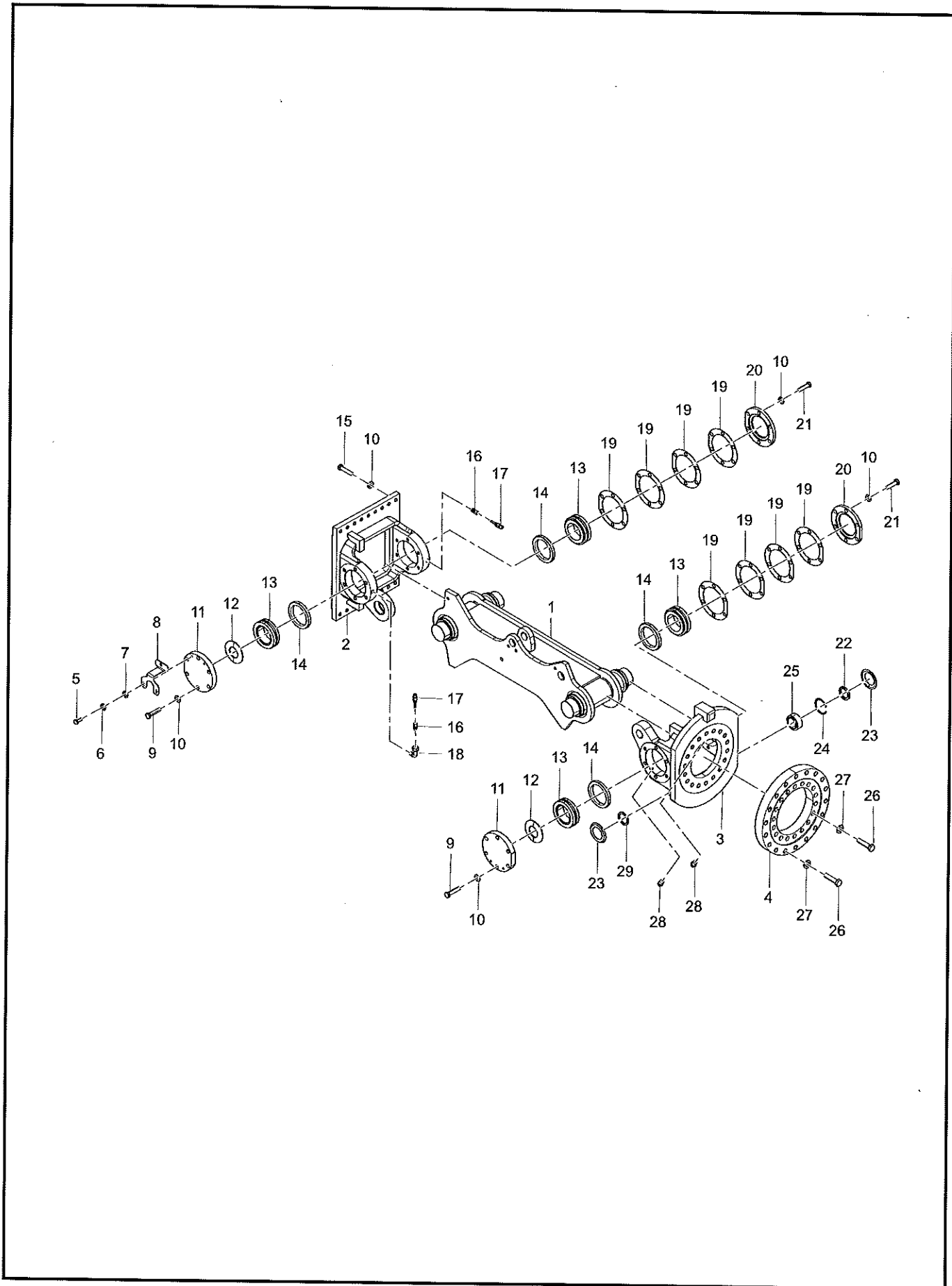

INDEX	PART NO.	DESCRIPTION	QTY	SEE PAGE
1	YLJ004856829	Hinged body	1	
2	YLJ004863424	Articulation Seat	1	
3	YLJ004846605	Rotary Support	1	
4	A229900002724	Slewing bearing	1	
5	A210111000089	Bolt	2	
6	A210401000017	Washer	2	
7	A210405000007	Washer	2	
8	YLJ004908102	Plate	1	
9	A210111000282	Bolt	12	
10	A210491000118	Washer	42	
11	YLJ004896675	Bearing cover	2	
12	A210491000003	Belleville Spring	2	
13	60082894	Joint Bearing	4	
14	YLJ004858996	Dust Ring	4	
15	A210111000291	Bolt	18	
16	60191773	Right-angle Joint, Clamp Sleeve-type	4	
17	60045017	Detachable Fitting	4	
18	60191772	Right-angle Joint, Clamp Sleeve-type	1	
19	YLJ004899944	Paper Washer	8	
20	YLJ004897639	Bearing cover	2	
21	A210111000281	Bolt	12	
22	13181668	Retainer Ring	2	
23	12359619	Sealing Ring	4	
24	A210416000034	Retainer Ring	2	
25	A210612000013	Joint Bearing	2	
26	A210110000201	Bolt	36	
27	A210491000132	Washer	36	
28	A210804000002	Oil Cup	4	
29	12359672	Retainer Ring	2	

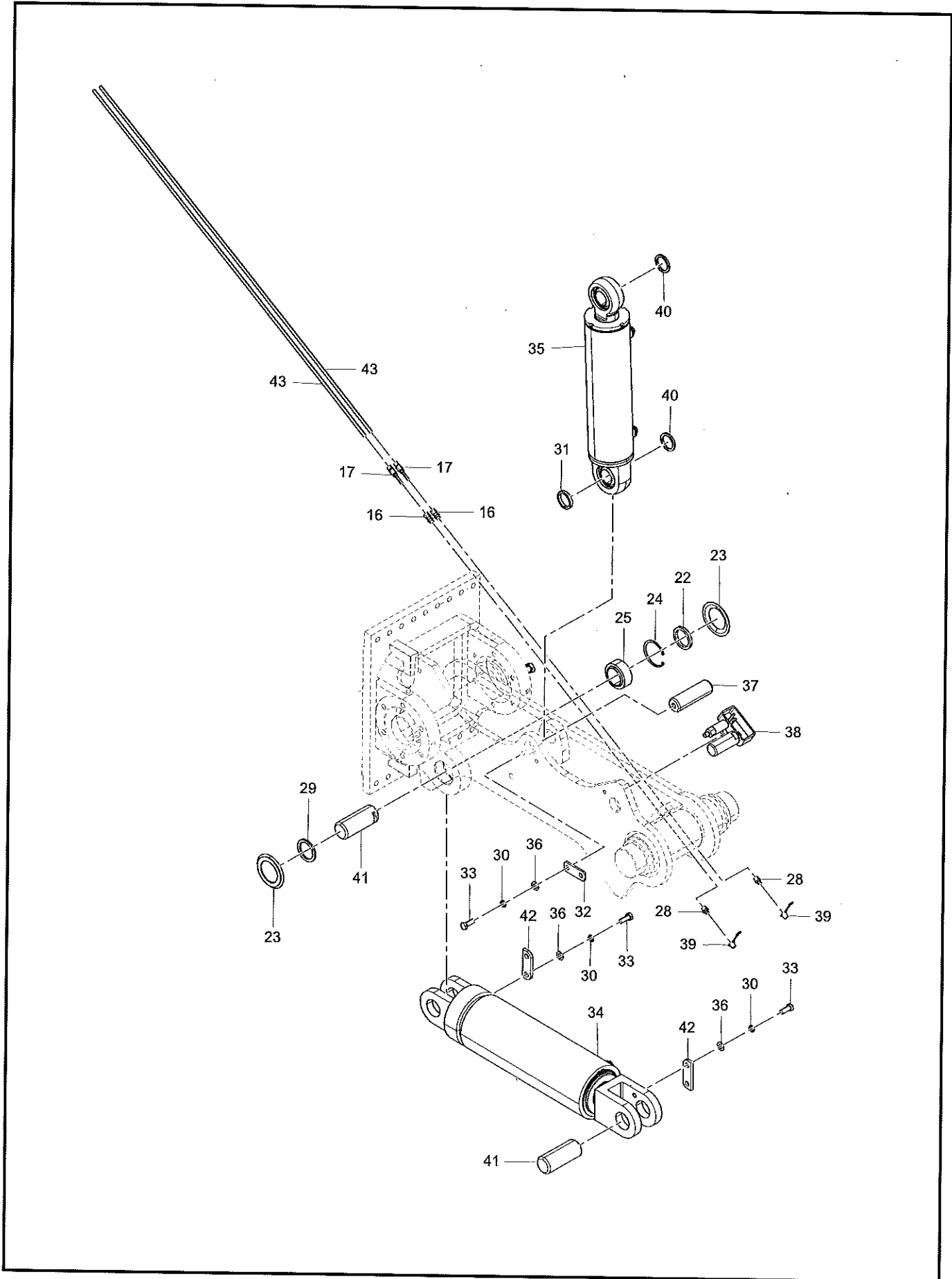

INDEX	PART NO.	DESCRIPTION	QTY	SEE PAGE
16	60191773	Right-angle Joint, Clamp Sleeve-type	4	
17	60045017	Detachable Fitting	4	
22	13181668	Retainer Ring	2	
23	12359619	Sealing Ring	4	
24	A210416000034	Retainer Ring	2	
25	A210612000013	Joint Bearing	2	
28	A210804000002	Oil Cup	4	
29	12359672	Retainer Ring	2	
30	A210401000002	Washer	6	
31	13297001	Retaining ring II	1	
32	A820101339360	Guard	1	
33	A210111000038	Bolt	6	
34	12364147	Steering Cylinder	1	6-6
35	14160181	Cylinder Assembly, Steering	1	6-8
36	A210405000001	Washer	6	
37	A820301018783	Shaft, pin	1	
38	12955991	Lock pin	1	6-10
39	A290000002660	Nozzle Universal Protective Cap	4	
40	13297012	Retainer Ring	2	
41	12360169	Lock pin	2	
42	A820101345222	Clamp Plate	2	
43	YLJ004899560	tube	2	





INDEX	PART NO.	DESCRIPTION	QTY	SEE PAGE
1	12364146	Clipping key cap	1	
2	12364145	Rear clipping key	1	
3	12364143	Piston	1	
4	12364148	Cylinder assem	1	
5	12364150	Piston rod assem.	1	
6	10250742	Retainer Ring	2	
7	12364139	Guide sleeve	1	
8	11123065	Snap ring	1	
9	11122499	Stopper ring	1	
10	A210434000011	Washer	2	
11	12355725	Screw Plug	2	
12	A210414000037	Retainer Ring	1	
13	B230101000138	OK Seal Ring	1	
14	A210609000062	O-ring	2	
15	B230101001371	UP Guide Ring	2	
16	B230101001492	UP Guide Ring	2	
17	A210609000009	O-ring	2	
18	13599611	GSJ Seal Ring	1	
19	B230101002124	ZBR Seal Ring	1	
20	A210414000015	Retainer Ring	1	
21	A880808070038	PWD Dust Ring	1	

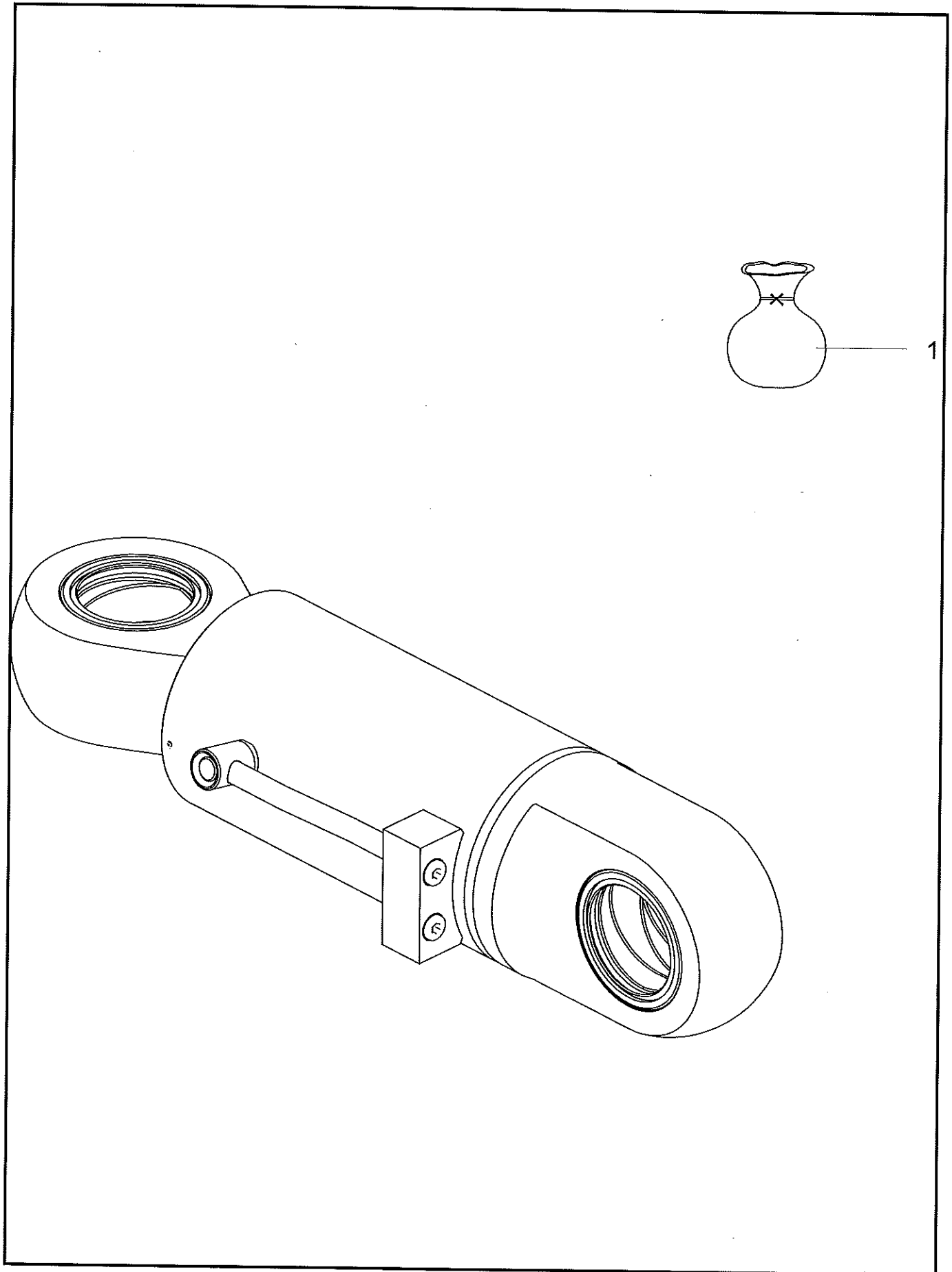

INDEX	PART NO.	DESCRIPTION	QTY	SEE PAGE
1	14163131	Package of process sealing parts	1	

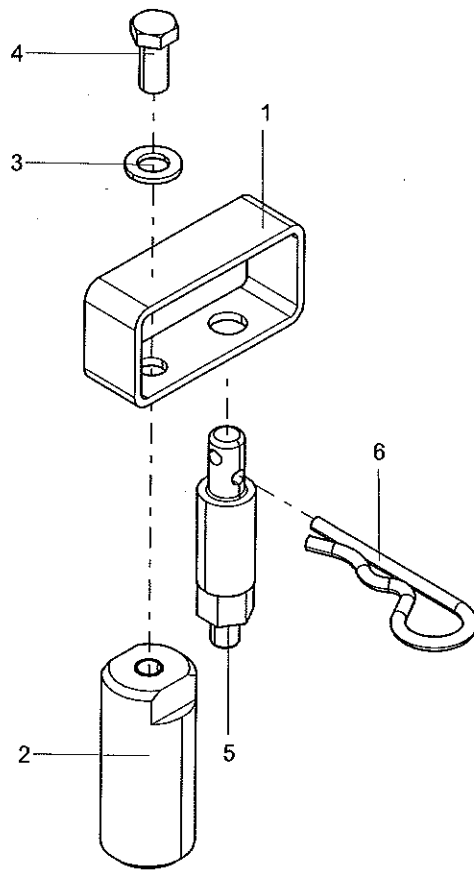

INDEX	PART NO.	DESCRIPTION	QTY	SEE PAGE
1	11109315	Handle	1	
2	12955989	Pin	1	
3	A210405000001	Washer	1	
4	A210111000037	Bolt	1	
5	11109312	Lock pin	1	
6	A820301010152	Clamp Pin	1	

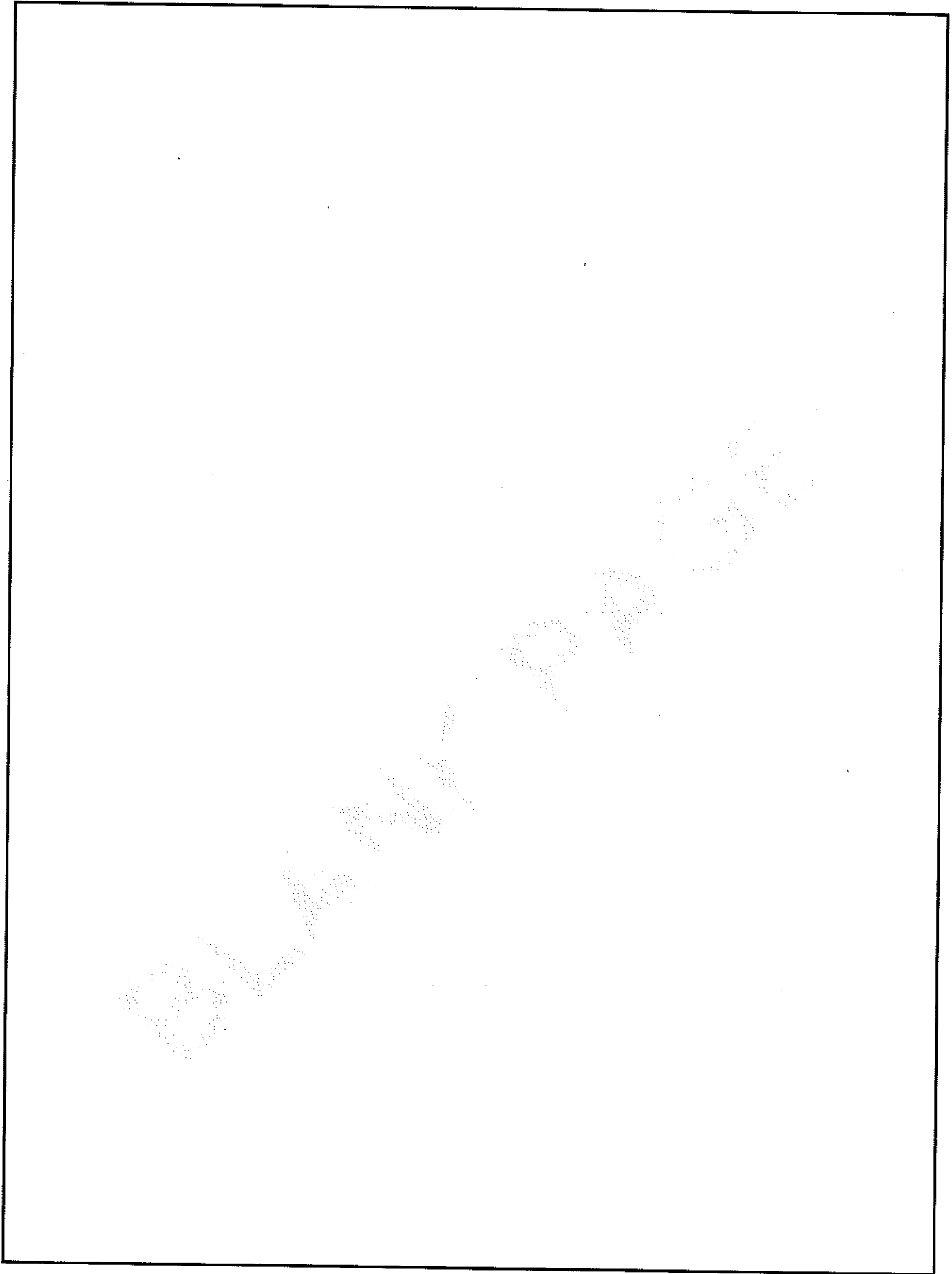

# Group 7

## Dynamical system

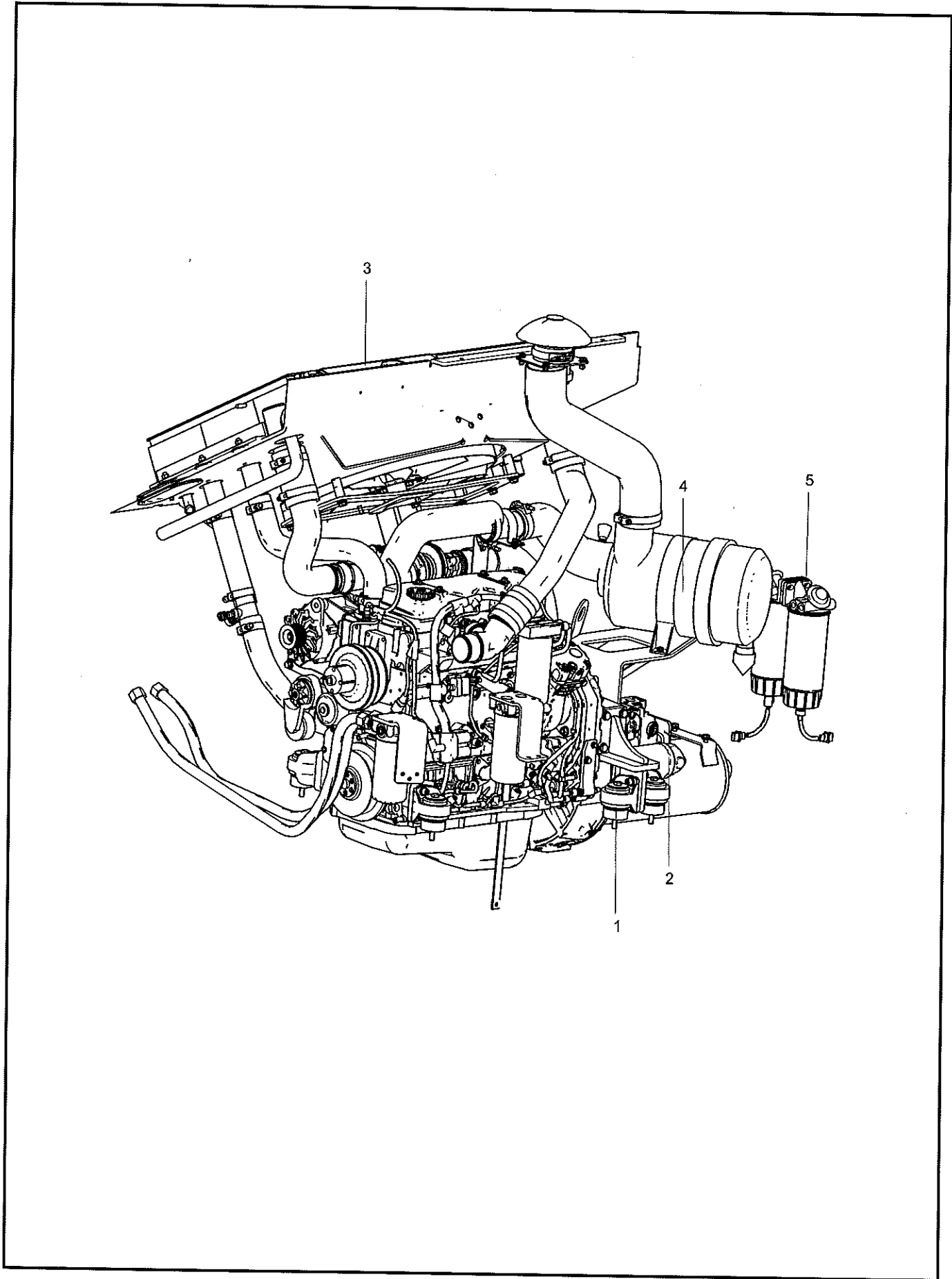



INDEX	PART NO.	DESCRIPTION	QTY	SEE PAGE
1	13920410	engine installation	1	7-4
2	14506058	pump connection	1	7-8
3	YLJ005110427	Cooling assembly	1	7-10
4	YLJ005110623	Exhaust System	1	7-14
5	YLJ005105952	Oil road and nearby installation	1	7-18

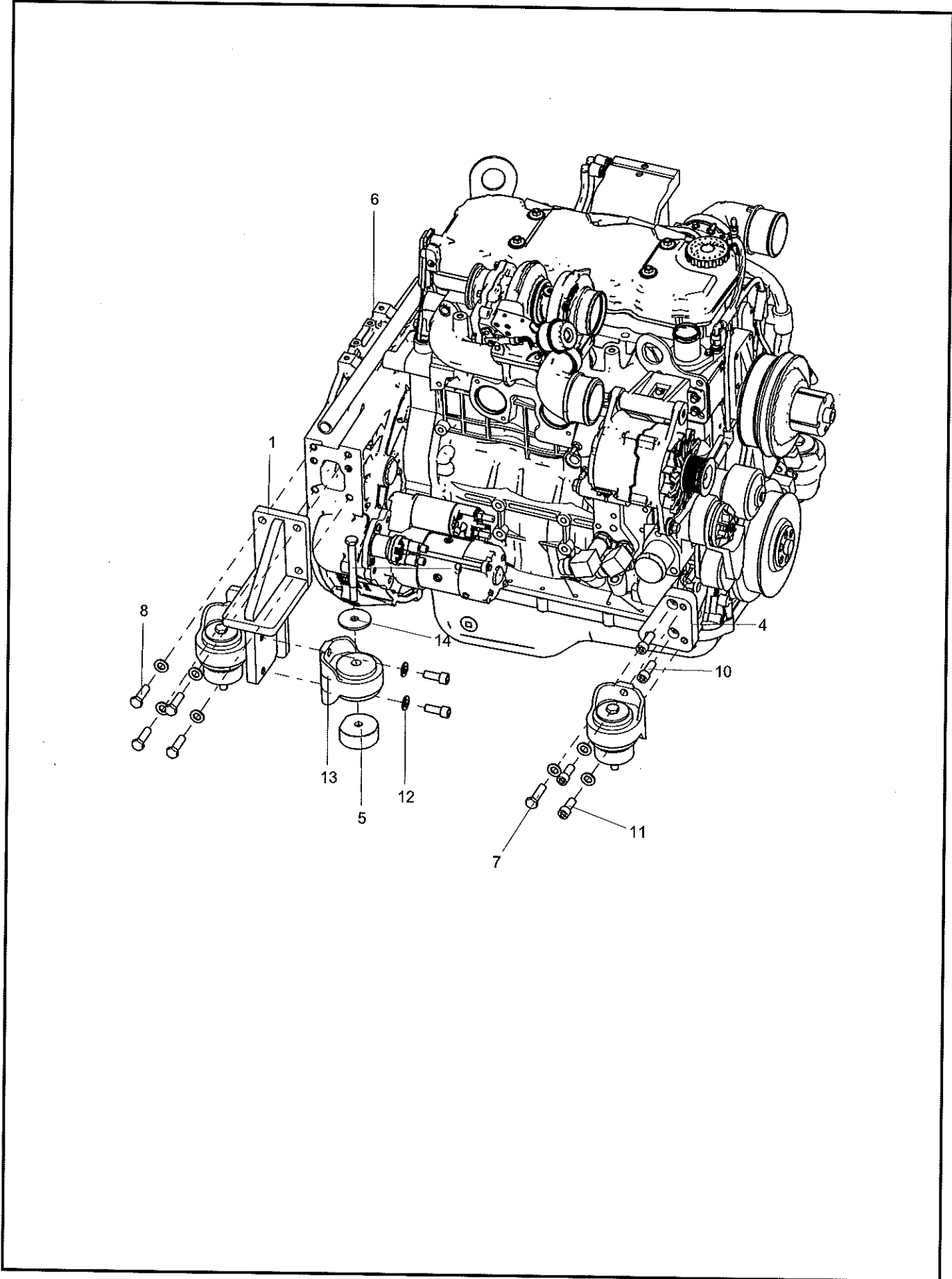

INDEX	PART NO.	DESCRIPTION	QTY	SEE PAGE
1	14217405	left outrigger welding assembly	1	
4	13589449	rear outrigger	1	
5	14217318	cushion block	6	
6	160102050024A	engine	1	
7	A210111000119	Bolt	2	
8	A210111000204	Bolt	8	
9	A210113000039	Bolt	6	
10	A210204000206	Screw	4	
11	A210204000337	Screw	12	
12	A210405000001	Washer	22	
13	A229900005421	Shock Pad	6	
14	A820202003593	Big Washer	6	

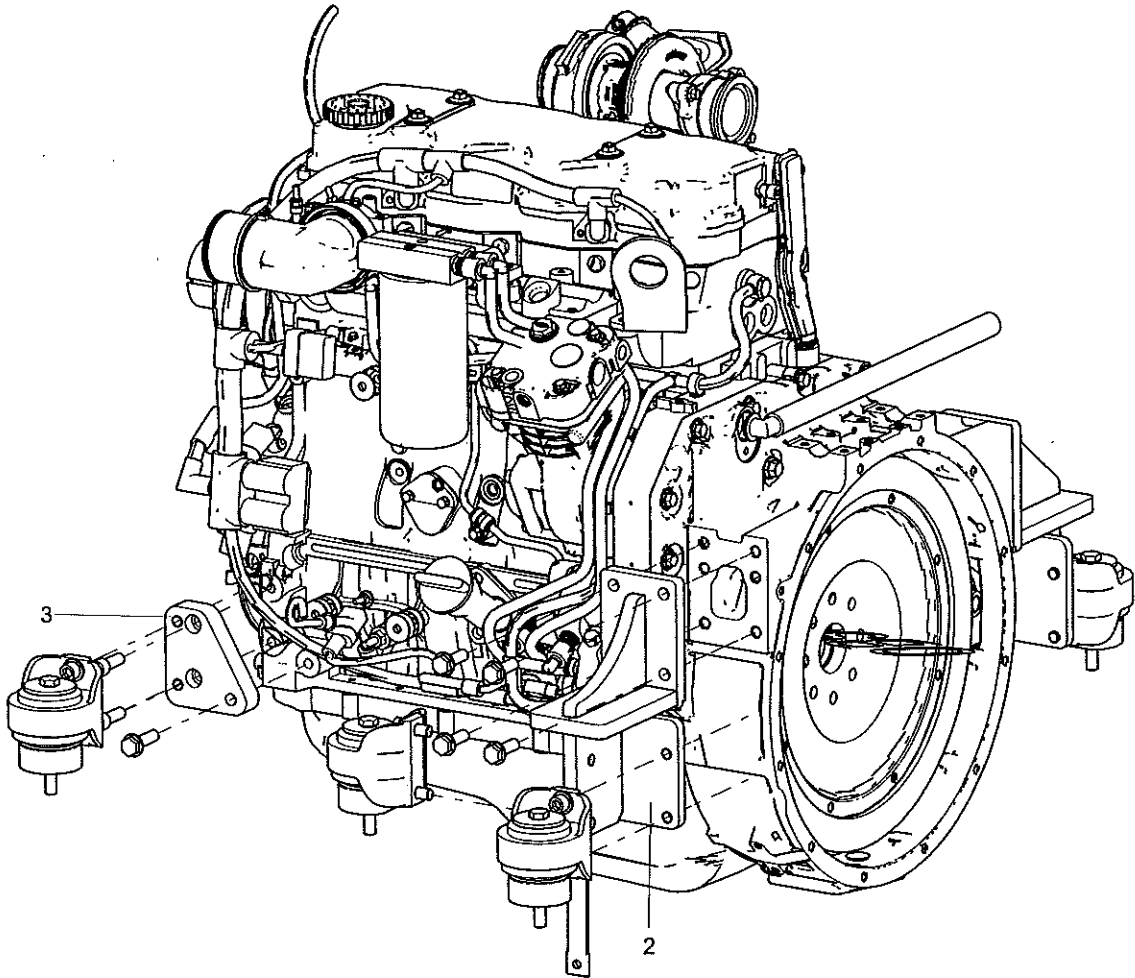

INDEX	PART NO.	DESCRIPTION	QTY	SEE PAGE
2	14217505	Right outrigger welding assembly	1	
3	13523768	Front bearer board	1	

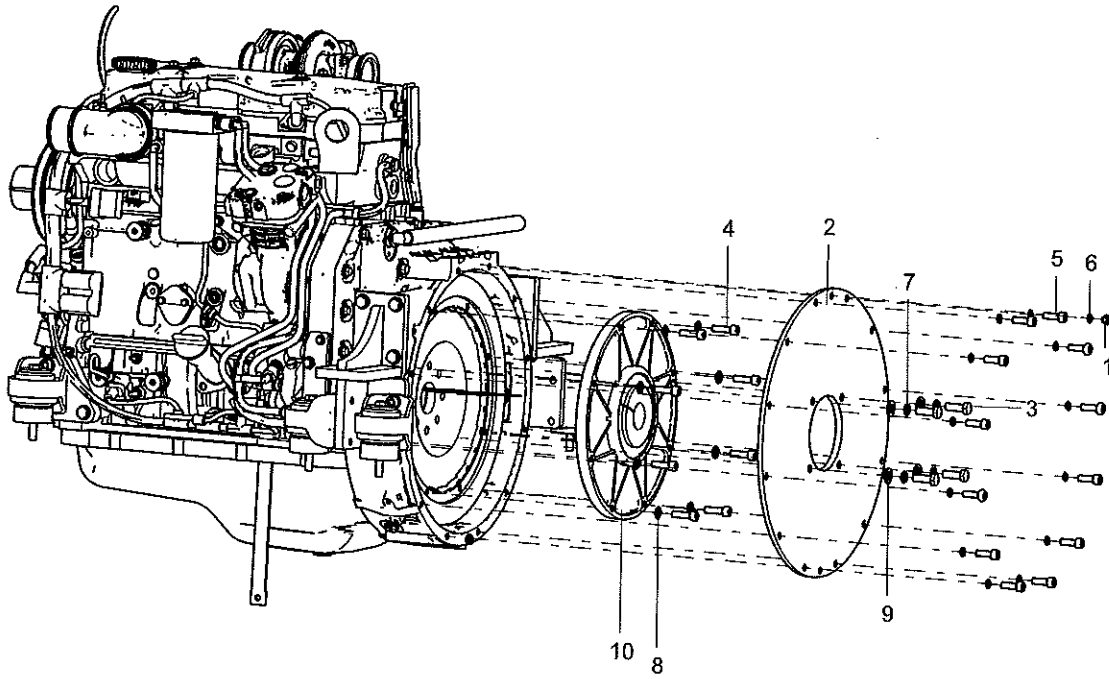

INDEX	PART NO.	DESCRIPTION	QTY	SEE PAGE
1	10891719	Threaded Cover	2	
2	13520944	Connecting Disk	1	
3	A210111000202	Bolt	4	
4	A210204000215	Screw	8	
5	A210204000354	Screw	12	
6	A210401000001	Washer	14	
7	A210401000002	Washer	4	
8	A210405000011	Washer	8	
9	A210491000121	Washer	4	
10	B221701000095	Flanging Coupling	1	

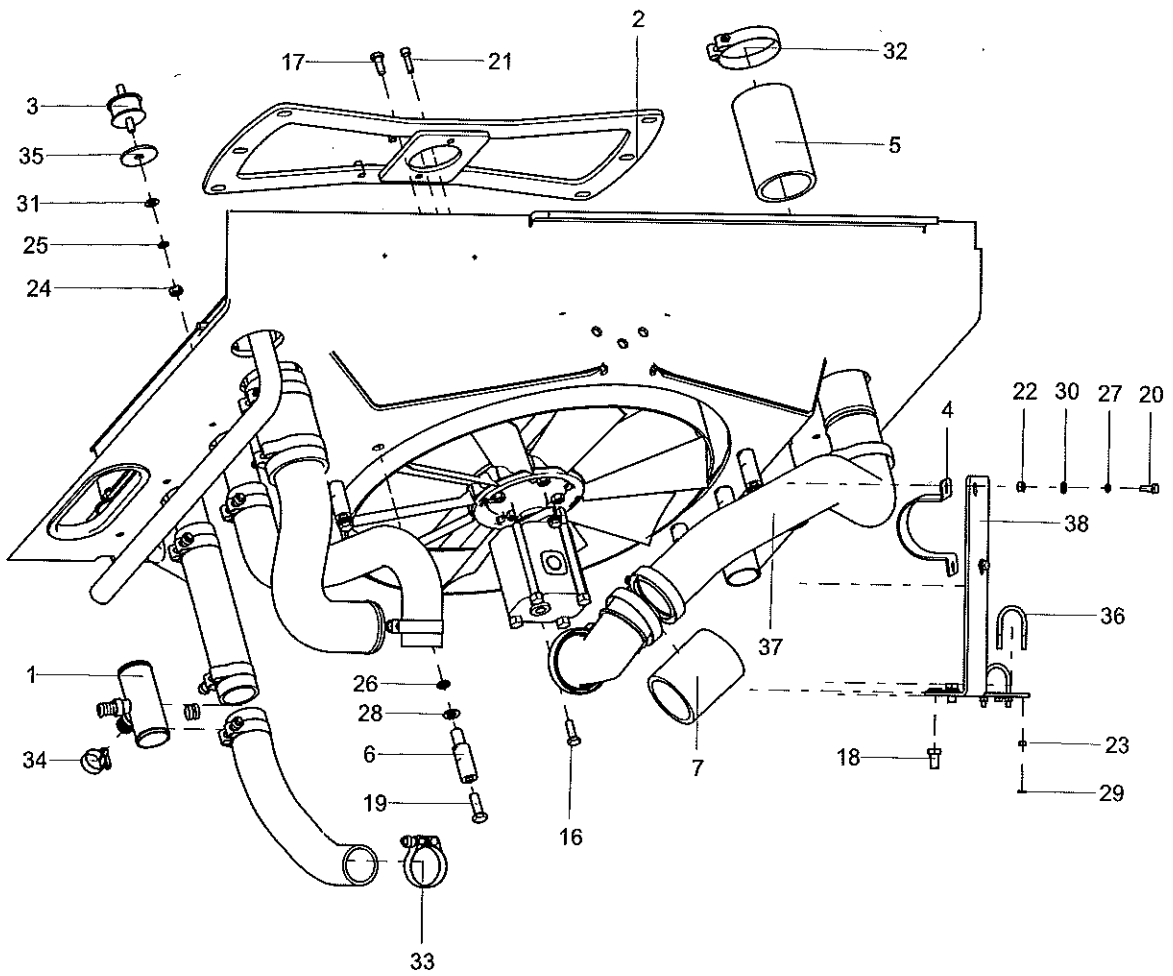



INDEX	PART NO.	DESCRIPTION	QTY	SEE PAGE
1	14184596	Weldment of watering tube	1	
2	YLJ006231480	Mounting plate of motor	1	
3	11101836	Damping Pad Of Radiator	6	
4	11558668	Hoop	1	
5	11563406	Connecting Rubber Hose	3	
6	13689958	Cushion block	6	
7	13919808	Connecting Rubber Hose	1	
16	A210111000024	Bolt	2	
17	A210111000197	Bolt	4	
18	A210111000199	Bolt	2	
19	A210111000203	Bolt	6	
20	A210111000343	Bolt	2	
21	A210204000164	Screw	1	
22	A210307000012	Nut	2	
23	A210307000016	Nut	4	
24	A210307000017	Nut	10	
25	A210401000001	Washer	12	
26	A210401000002	Washer	8	
27	A210401000017	Washer	2	
28	A210405000001	Washer	8	
29	A210405000006	Washer	4	
30	A210405000007	Washer	3	
31	A210405000011	Washer	12	
32	A210855000052	T-type Anchor Ear	8	
33	A229900002031	T-type Anchor Ear	6	
34	A229900002965	Hose Clamp	1	
35	A820202003593	Big Washer	6	
36	A820301012683	Screw Rod, U-type	2	
37	YLJ005359029	Out air	1	
38	YLJ005683988	Plate	1	

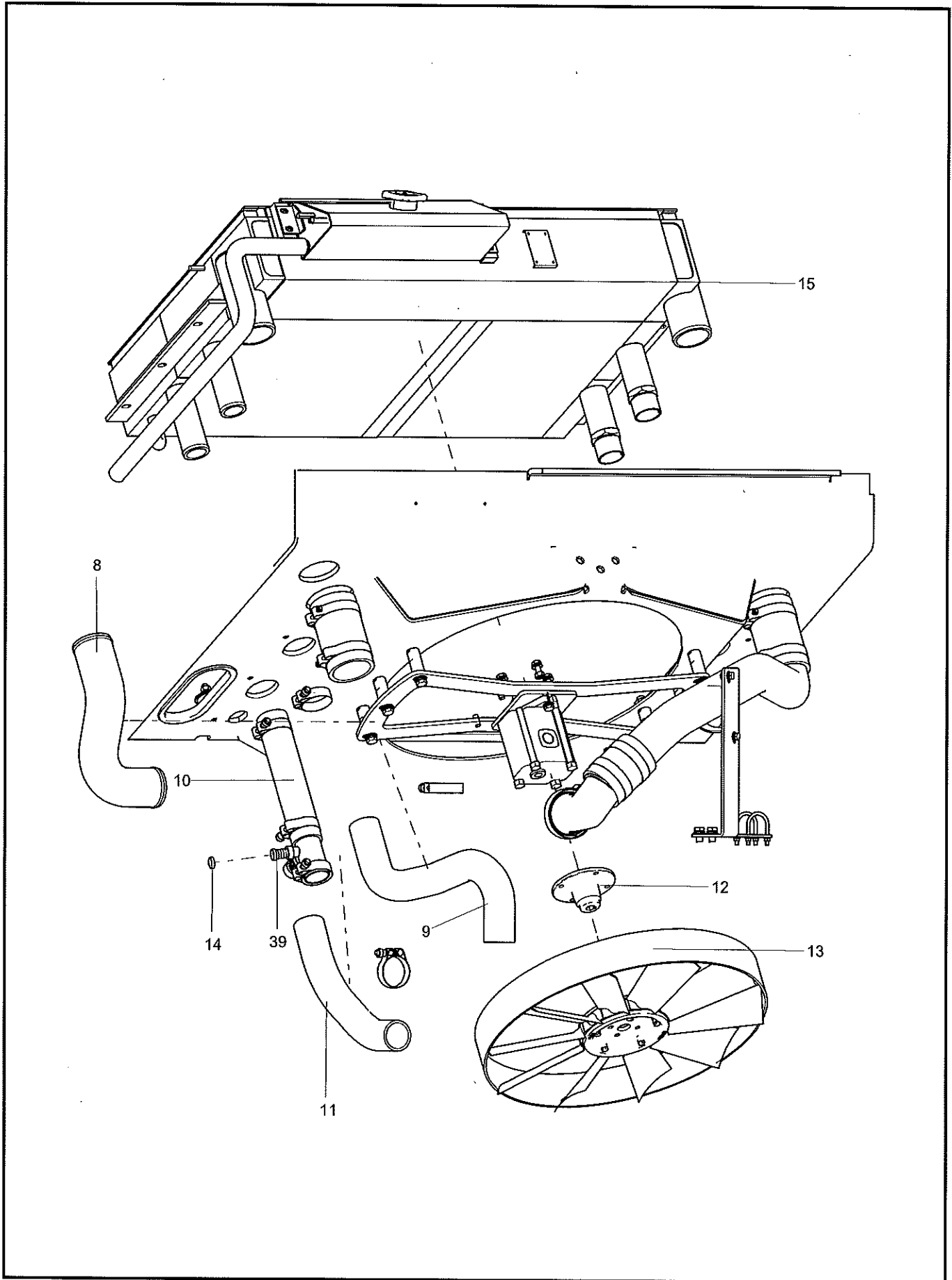

INDEX	PART NO.	DESCRIPTION	QTY	SEE PAGE
8	13919828	Inter-cooler intake pipe	1	
9	13919833	Discharging tube	1	
10	14057294	water-in tube	1	
11	14057339	water-in tube	1	
12	14414864	Installation adaptor of fan	1	
13	60034933	Fan	1	
14	60134354	Throat Collar	2	
15	60340908	Radiator	1	
39	13718118	Degassing pipe	1	

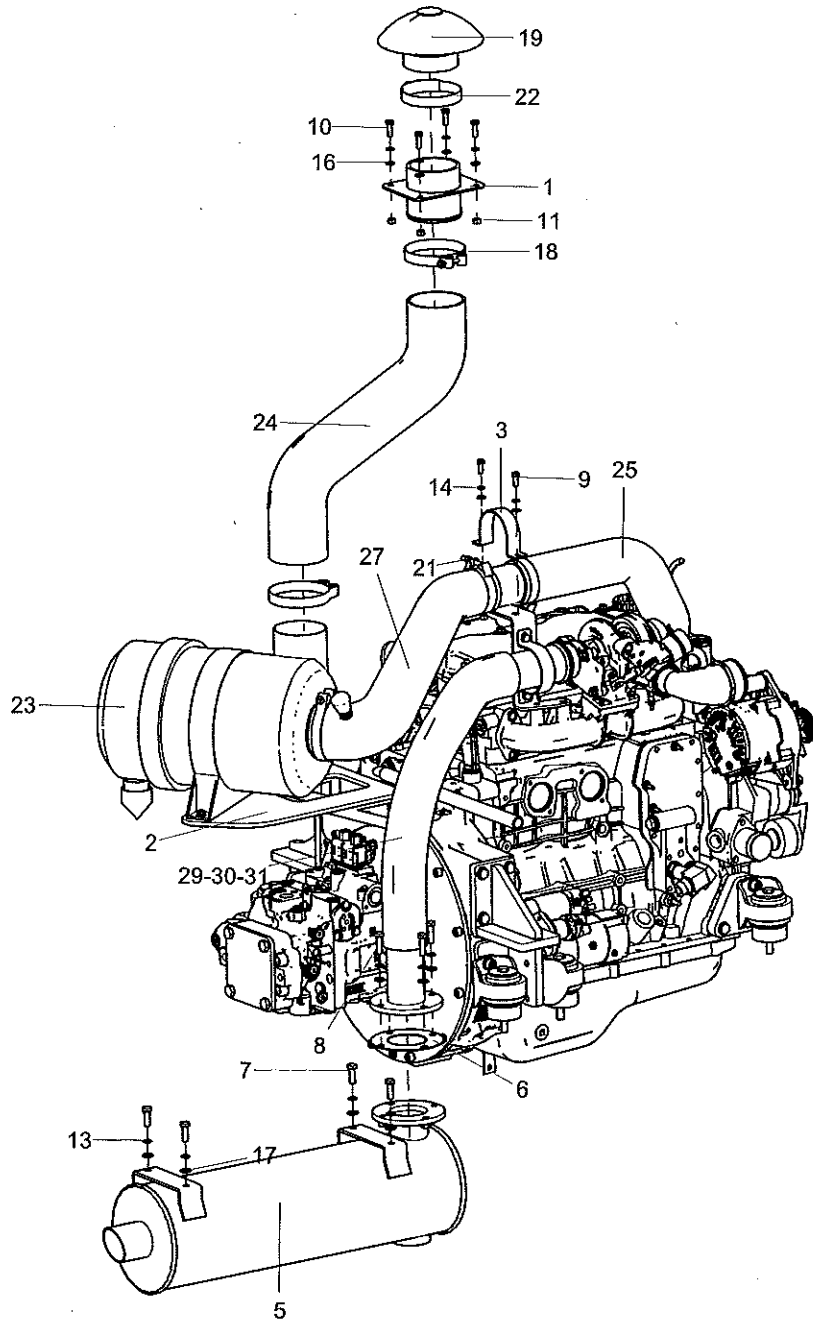

INDEX	PART NO.	DESCRIPTION	QTY	SEE PAGE
1	YLJ004758616	Mounting Assem.	1	
2	YLJ005359967	mounting assem. for air cleaner	1	
3	11558668	Hoop	2	
5	13673659	muffler	1	
6	13688588	Exhaust Pipe Spacer	1	
7	A210111000024	Bolt	4	
8	A210111000026	Bolt	4	
9	A210111000089	Bolt	4	
10	A210111000090	Bolt	6	
11	A210307000012	Nut	10	
13	A210401000001	Washer	8	
14	A210401000017	Washer	10	
16	A210405000007	Washer	10	
17	A210405000011	Washer	8	
18	A229900002263	T-type Clamp	3	
19	A229900002381	Rain Hat	1	
21	A229900003759	T-type Anchor Ear	3	
22	A229900003898	T-type Anchor Ear	1	
23	B222100000368	Air Filter	1	
24	YLJ005358886	In air	1	
25	YLJ005358917	In air	1	
27	YLJ005359665	In air	1	
29	13921420	Exhaust hose	1	
30	A230200000026	PTFE glass fiber varnish cloth	1	
31	A239900000239	Fiberglass felt strip	1	

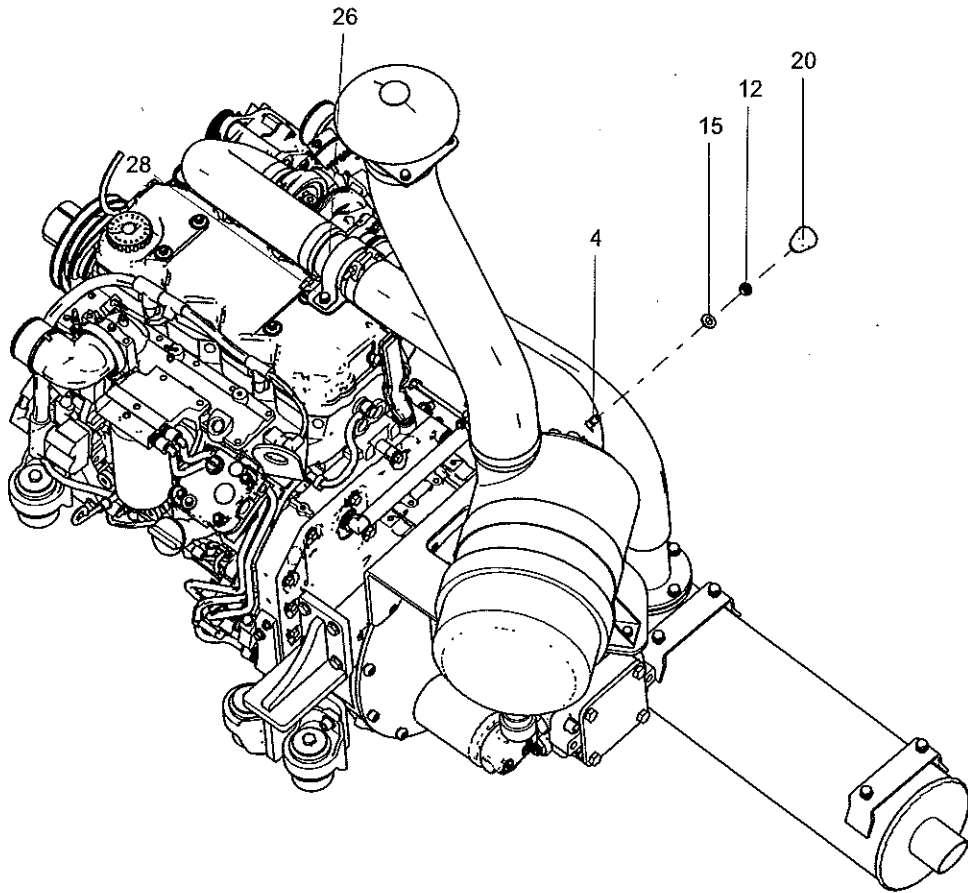

INDEX	PART NO.	DESCRIPTION	QTY	SEE PAGE
4	13300057	Sensor Connector	1	
12	A210309000016	Nut	1	
15	A210405000001	Washer	1	
20	A229900003542	Mechanical Differential Pressure Indicator	1	
26	YLJ005358995	In air	1	
28	YLJ005359771	bracket for exhaust hose	1	

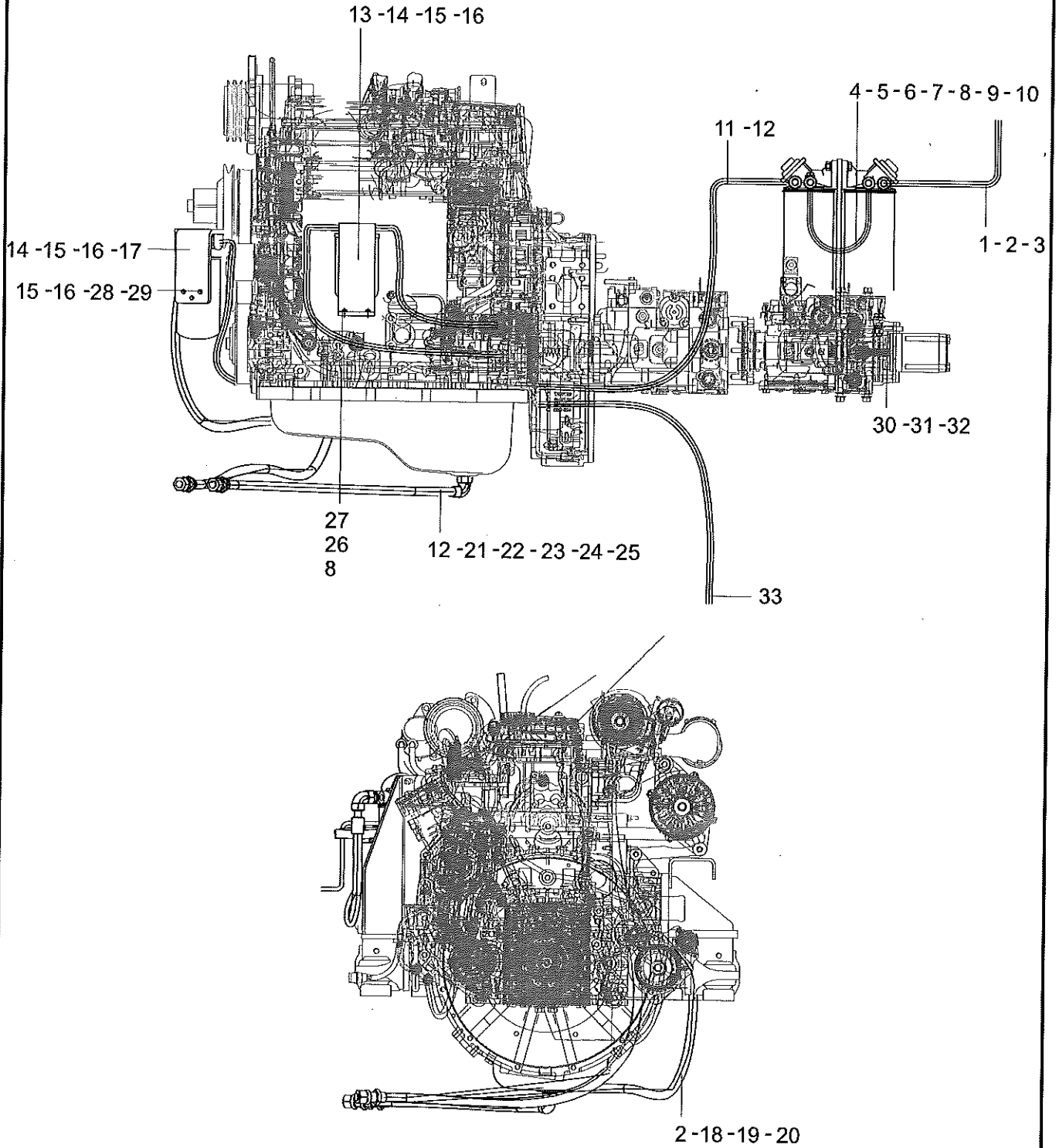



INDEX	PART NO.	DESCRIPTION	QTY	SEE PAGE
1	B210780000344	Adapter Fitting	5	
2	B210780000245	Bulkhead Fitting	4	
3	B230103007493	Rubber Hose	1	
4	60312939	Rubber Hose	1	
5	B210780001026	Adapter Fitting	4	
6	B210780000636	Elbow Fitting	2	
7	A210111000029	Bolt	2	
8	A210405000011	Washer	4	
9	A210307000017	Nut	2	
10	14274679	prefiltration support	1	
11	B230103000129	Hose	1	
12	B210780000025	Elbow Fitting	4	
13	13922408	ecise filtration supporting board	1	
14	A210111000091	Bolt	8	
15	A210405000007	Washer	11	
16	A210401000017	Washer	11	
17	13922412	Engine oil cleaner filtration supporting board	1	
18	21017994	Screw Plug	2	
19	B230103000949	Hose	1	
20	13925123	Drainage adaptor	1	
21	B210780000040	Fitting, Adapter	1	
22	B230103000043	Rubber hose	1	
23	A210405000010	Washer	2	
24	A210405000014	Washer	1	
25	13765129	Preheating Mounting Rack	1	
26	A210111000023	Bolt	2	
27	A210401000001	Washer	2	
28	A210111000094	Bolt	3	
29	A210307000012	Nut	3	
30	A210111000040	Bolt	2	
31	A210405000001	Washer	2	
32	A210307000001	Nut	2	
33	21021914	Rubber Hose	1	

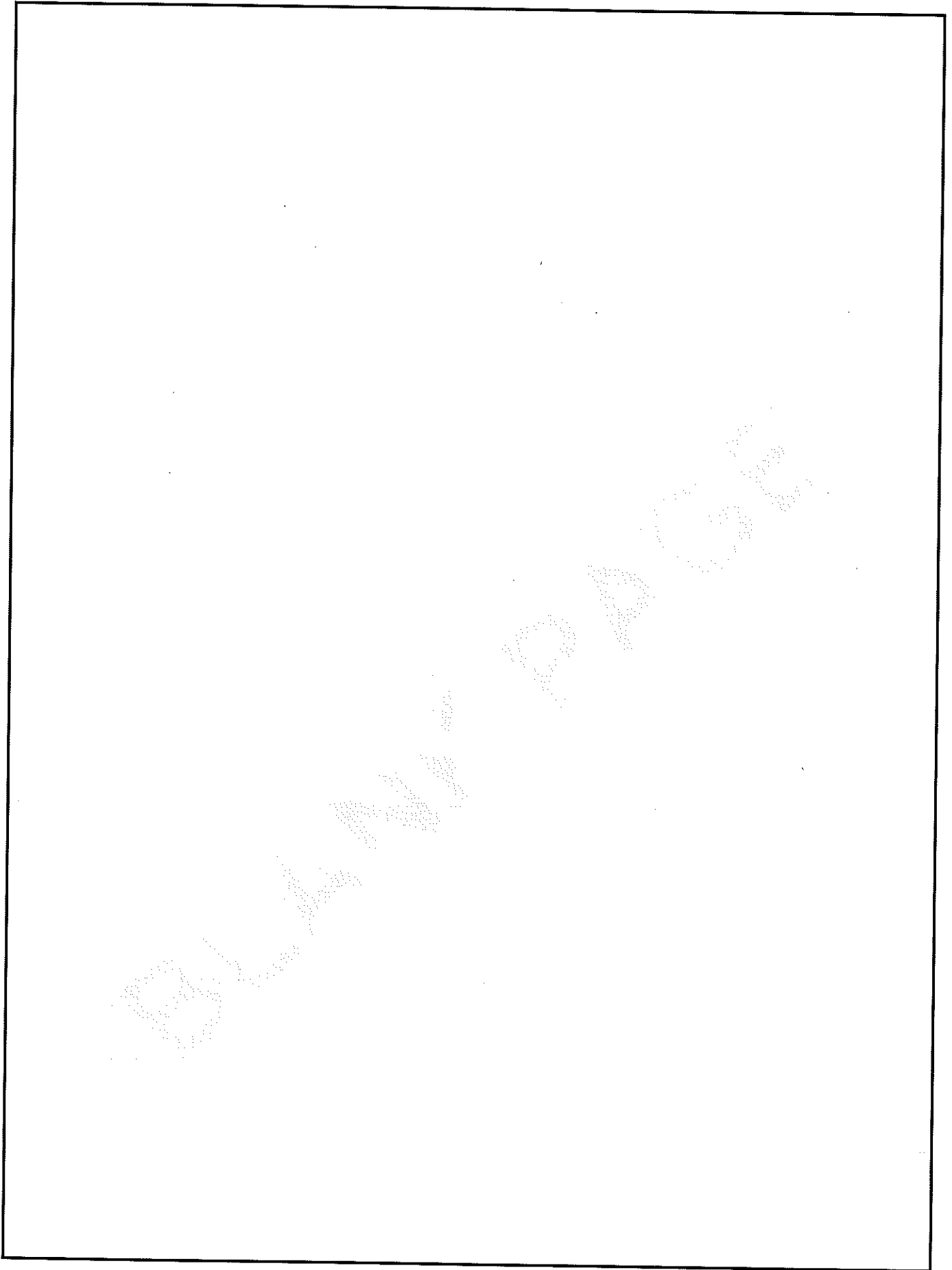

# Group 8

## Hydraulic system assembly

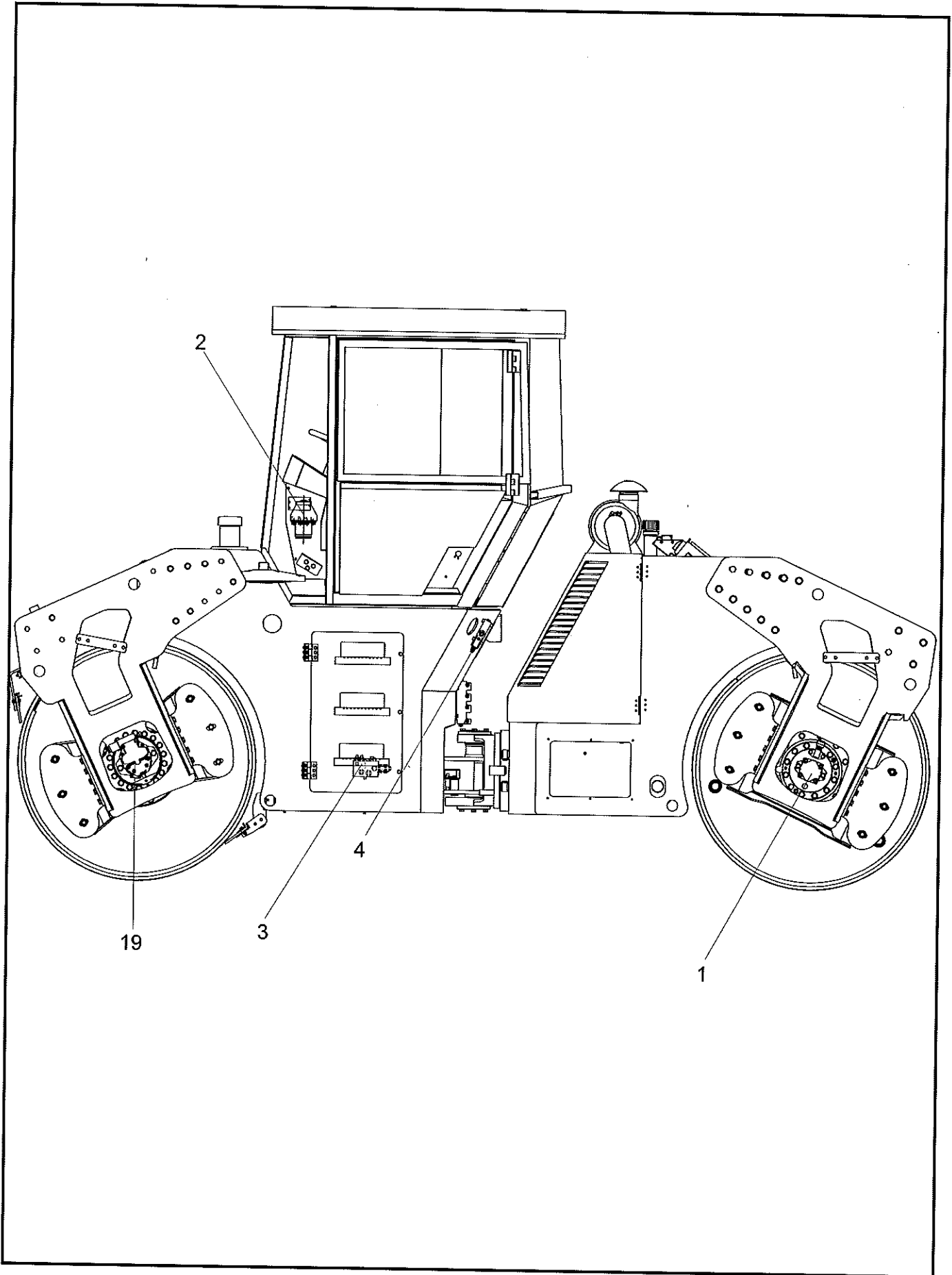

INDEX	PART NO.	DESCRIPTION	QTY	SEE PAGE
1	14511380	Traveling motor	1	8-6
2	13686364	Steering component	1	8-8
3	13448213	Crablike valve mounting	1	8-10
4	13686363	Priority valve assembly	1	8-12
19	YLJ005720436	Traveling motor	1	8-42

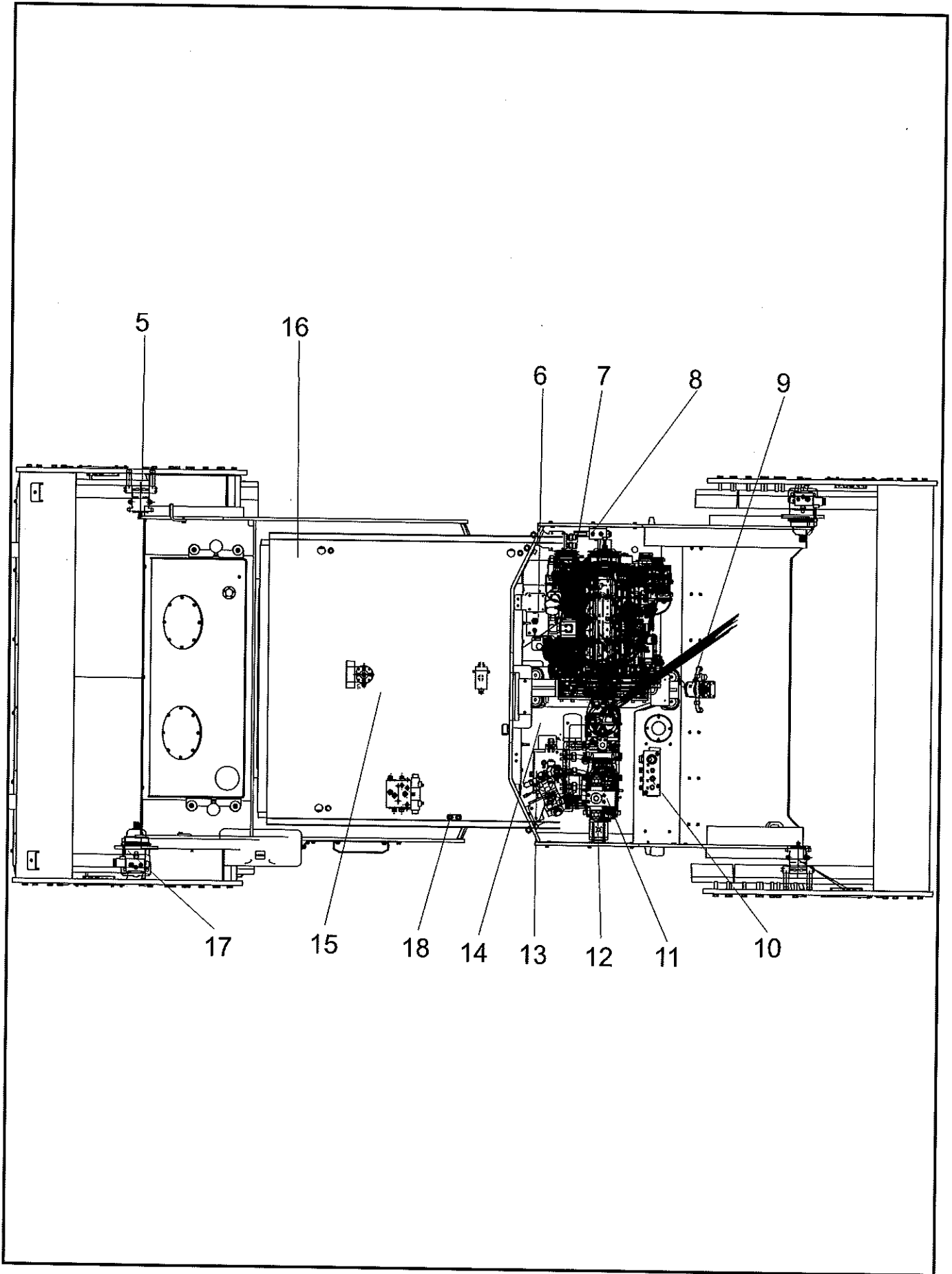

INDEX	PART NO.	DESCRIPTION	QTY	SEE PAGE
5	14511533	Vibratory motor	2	8-14
6	13917318	Return Block assembly	1	8-16
7	14511708	Steering Pump	1	8-18
8	13686274	Fan valve mounting	1	8-20
9	14511747	Fan motor component	1	8-22
10	13916302	BLOCK OF collecting assembly	1	8-24
11	13918399	filter assembly	1	8-26
12	14512102	Triple Pump	1	8-28
13	A810201060027	Vibration switch valve installation	1	8-30
14	14513076	Radiator of vibratory system	1	8-32
15	14513087	Pipeline layout of brake and steering systems	1	8-34
16	14513010	Piping diagram of vibratory system	1	8-36
17	14512830	Piping diagram of traveling system	1	8-38
18	13989791	Braking valve mounting	1	8-40

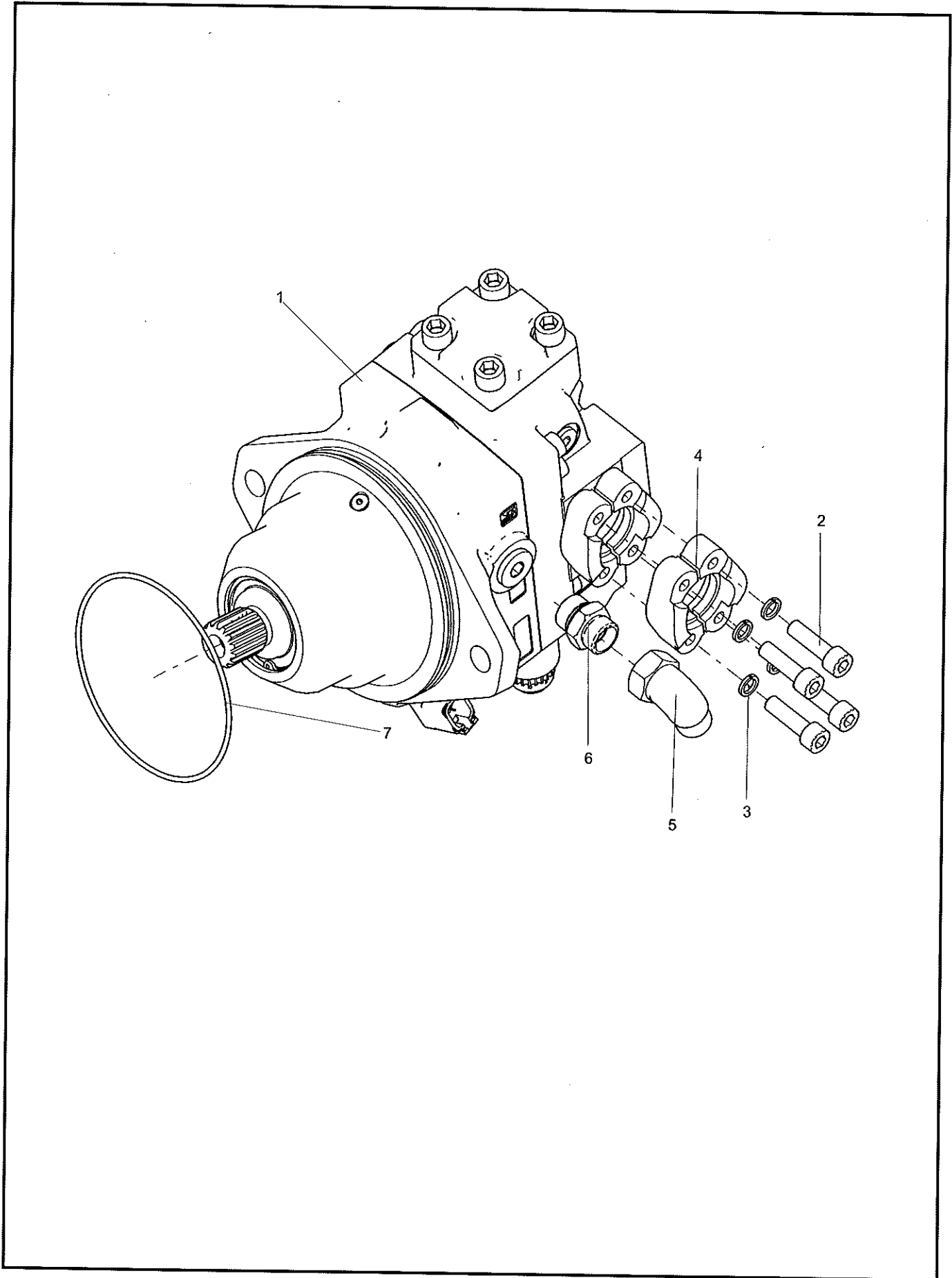



INDEX	PART NO.	DESCRIPTION	QTY	SEE PAGE
1	150202040038B	Plunger Motor	1	
2	A210204000215	Screw	8	
3	A210401000001	Washer	8	
4	B210780000007	Split Flange	4	
5	B210780000025	Elbow Fitting	1	
6	B210780000587	Adapter Fitting	1	
7	B230101000461	O-ring	1	

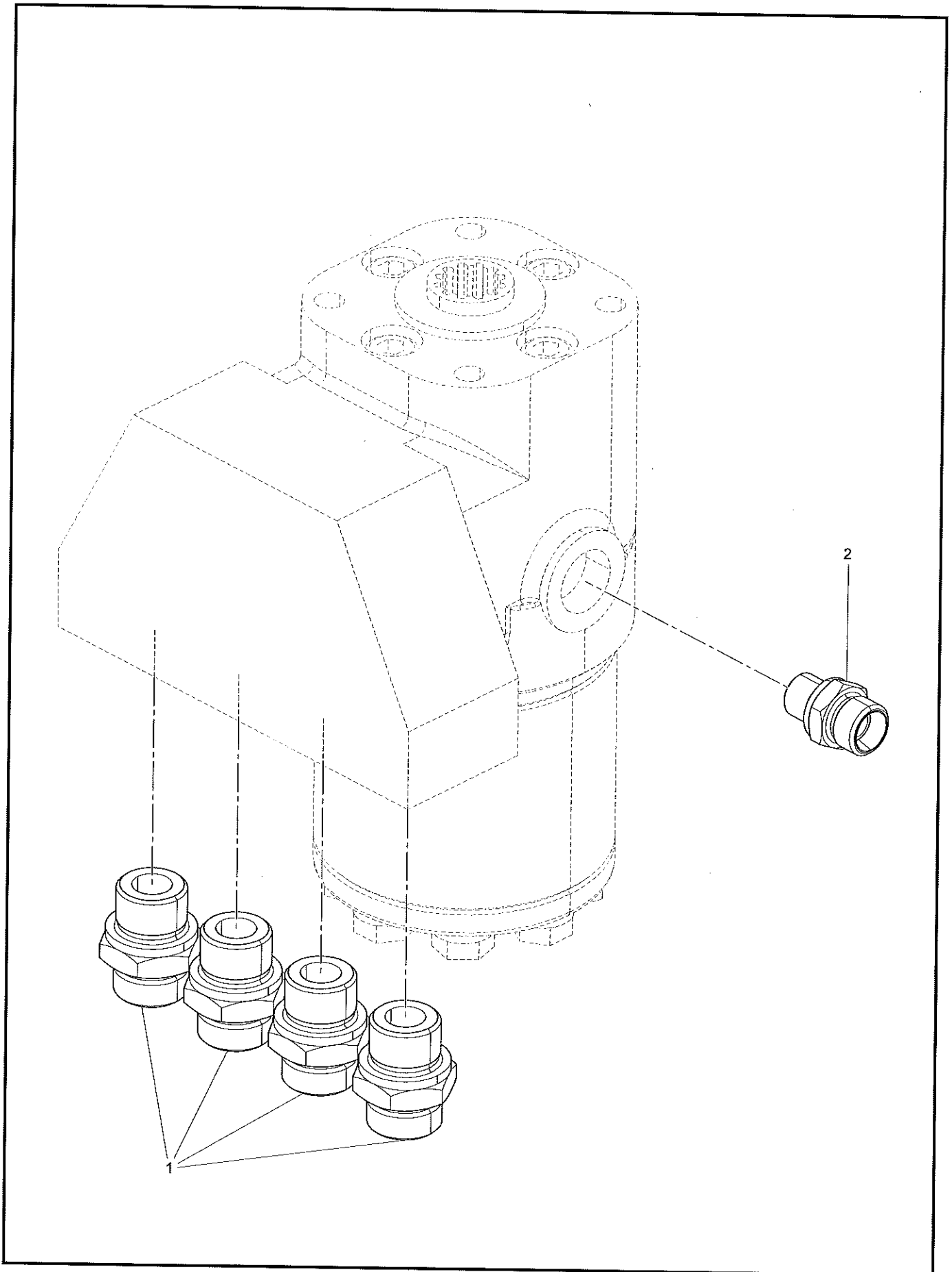

INDEX	PART NO.	DESCRIPTION	QTY	SEE PAGE
1	B21078000043	Fitting	4	
2	B210780000733	Adapter Fitting	1	

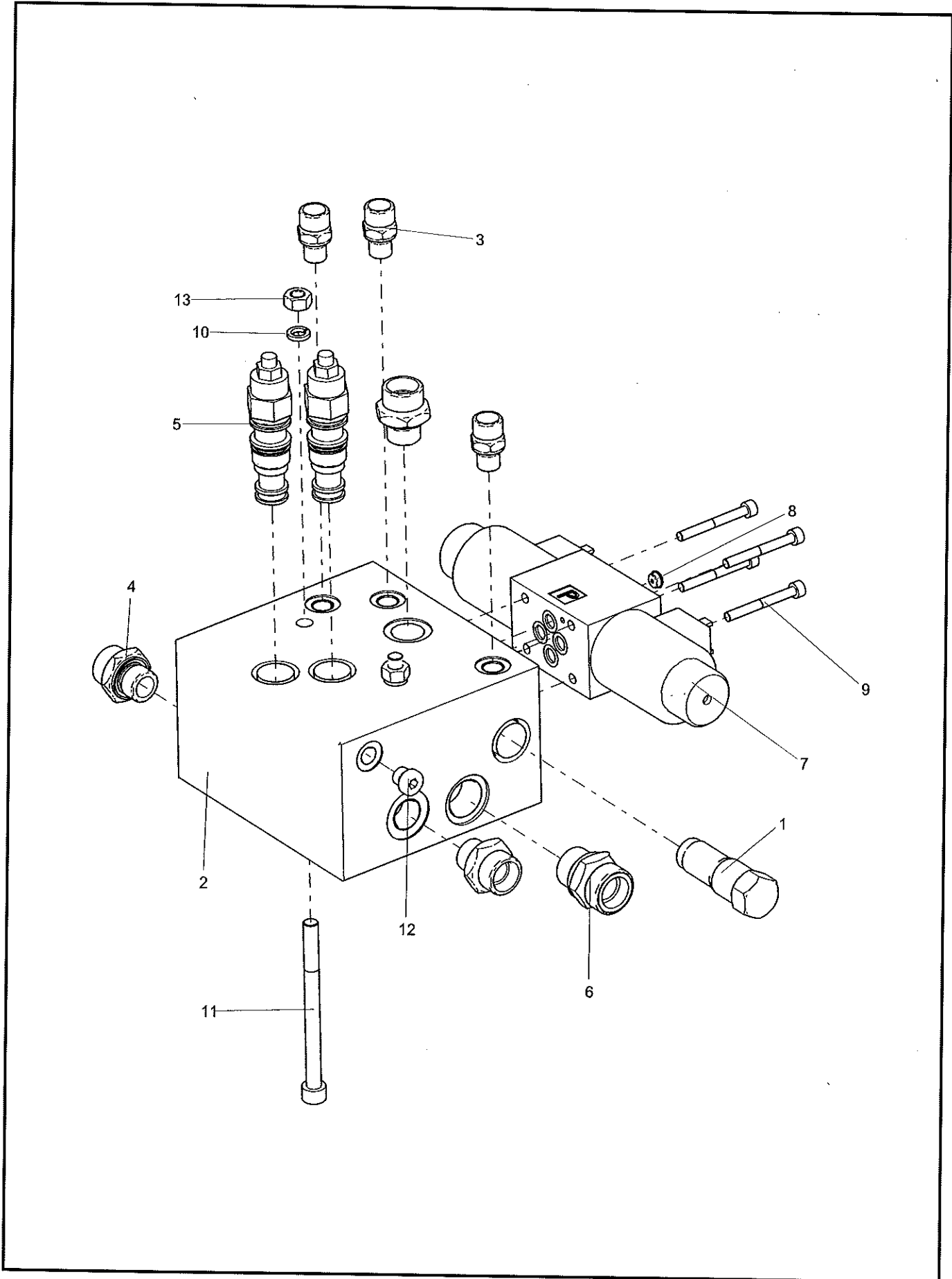

INDEX	PART NO.	DESCRIPTION	QTY	SEE PAGE
1	B220401001276	Shuttle Valve	2	
2	13448212	Valve block	1	
3	B210780001286	Adapter Fitting	3	
4	B210780000040	Fitting, Adapter	4	
5	60235408	Hydraulic Control One-way Valve	2	
6	B210780000131	Adapter Fitting	1	
7	60035539	Electromagnetic Reversing Valve	1	
8	60033445	Throttle Screw Plug	1	
9	A210204000122	Screw	4	
10	A210401000017	Washer	2	
11	60249822	Screw	2	
12	B210399000003	Screw Plug	8	
13	A210307000012	Nut	2	

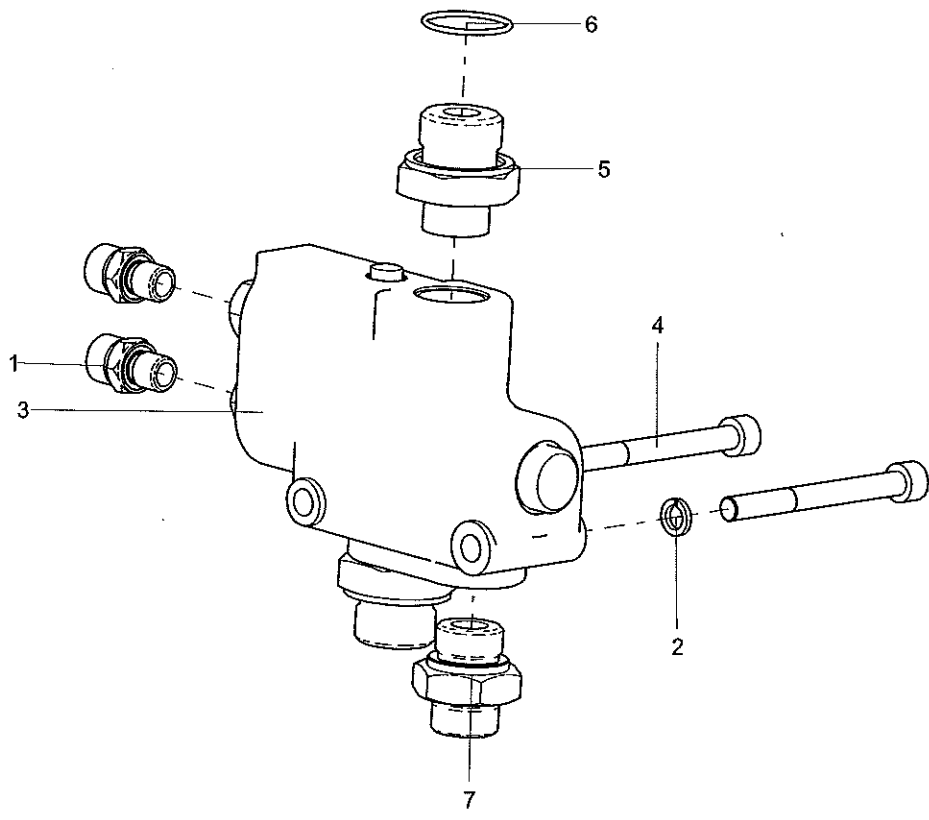

INDEX	PART NO.	DESCRIPTION	QTY	SEE PAGE
1	B210780001286	Adapter Fitting	2	
2	A210401000017	Washer	2	
3	A220401000030	Priority Valve	1	
4	A210204000179	Screw	2	
5	A820205000995	Pipe connector	2	
6	A210609000041	O-ring	2	
7	B210780000266	Adapter Fitting	1	

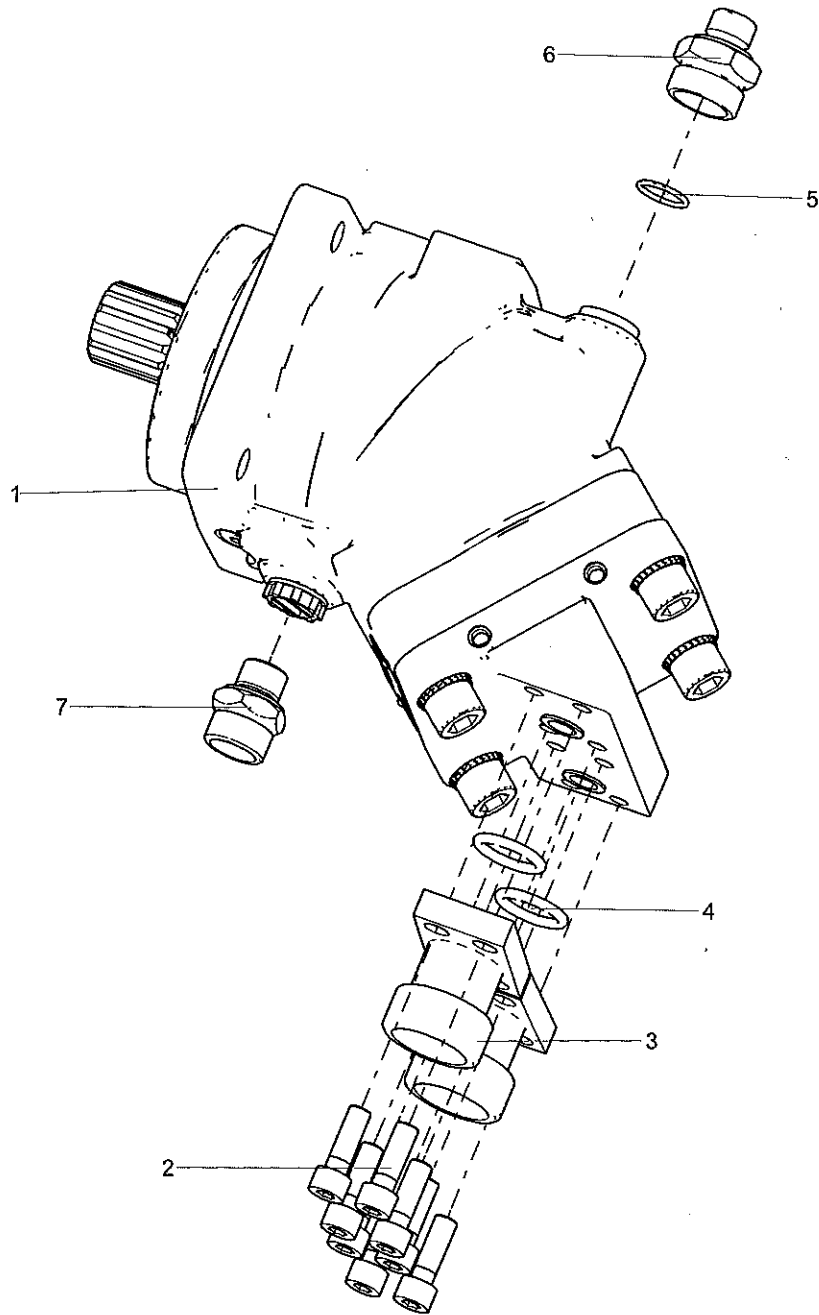



INDEX	PART NO.	DESCRIPTION	QTY	SEE PAGE
1	60105336	Plunger Motor	1	
2	A210204000162	Screw	8	
3	A820203000641	Flange Straight Joint	2	
4	B230101000233	O-ring	2	
5	B230101000241	O-ring	1	
6	13308908	Pipe Connector of LINON Motor	1	
7	B210780000344	Adapter Fitting	1	

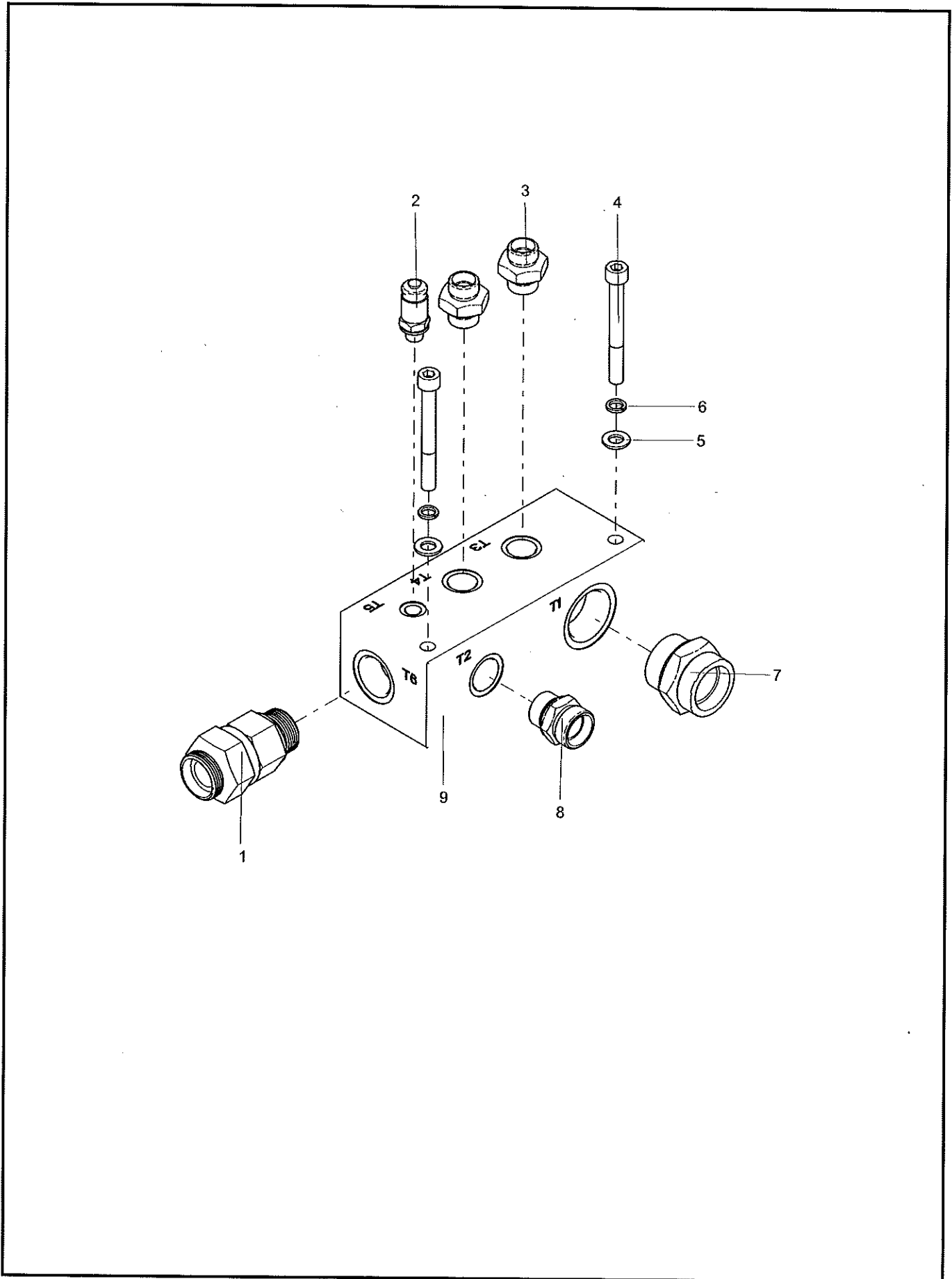

INDEX	PART NO.	DESCRIPTION	QTY	SEE PAGE
1	60311658	Check Valve	1	
2	B210780001749	Pressure-measuring Fitting	1	
3	B210780000266	Adapter Fitting	2	
4	A210204000017	Screw	2	
5	A210405000011	Washer	2	
6	A210401000001	Washer	2	
7	B210780000054	Adapter Fitting	1	
8	B210780000049	Adapter Fitting	1	
9	13917155	Return Block	1	

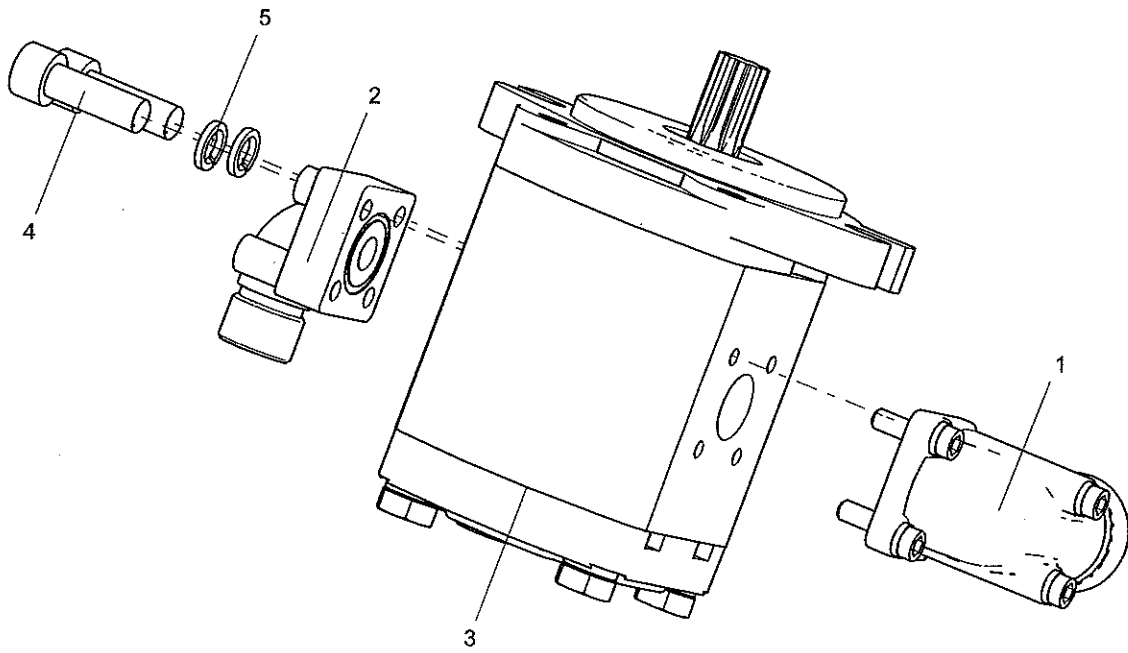

INDEX	PART NO.	DESCRIPTION	QTY	SEE PAGE
1	B210780000652	Square Flange Right-angle Joint	1	
2	B210780000438	Square Flange Right-angle Joint	1	
3	60280112	Gear Pump	1	
4	A210204000354	Screw	2	
5	A210401000001	Washer	2	

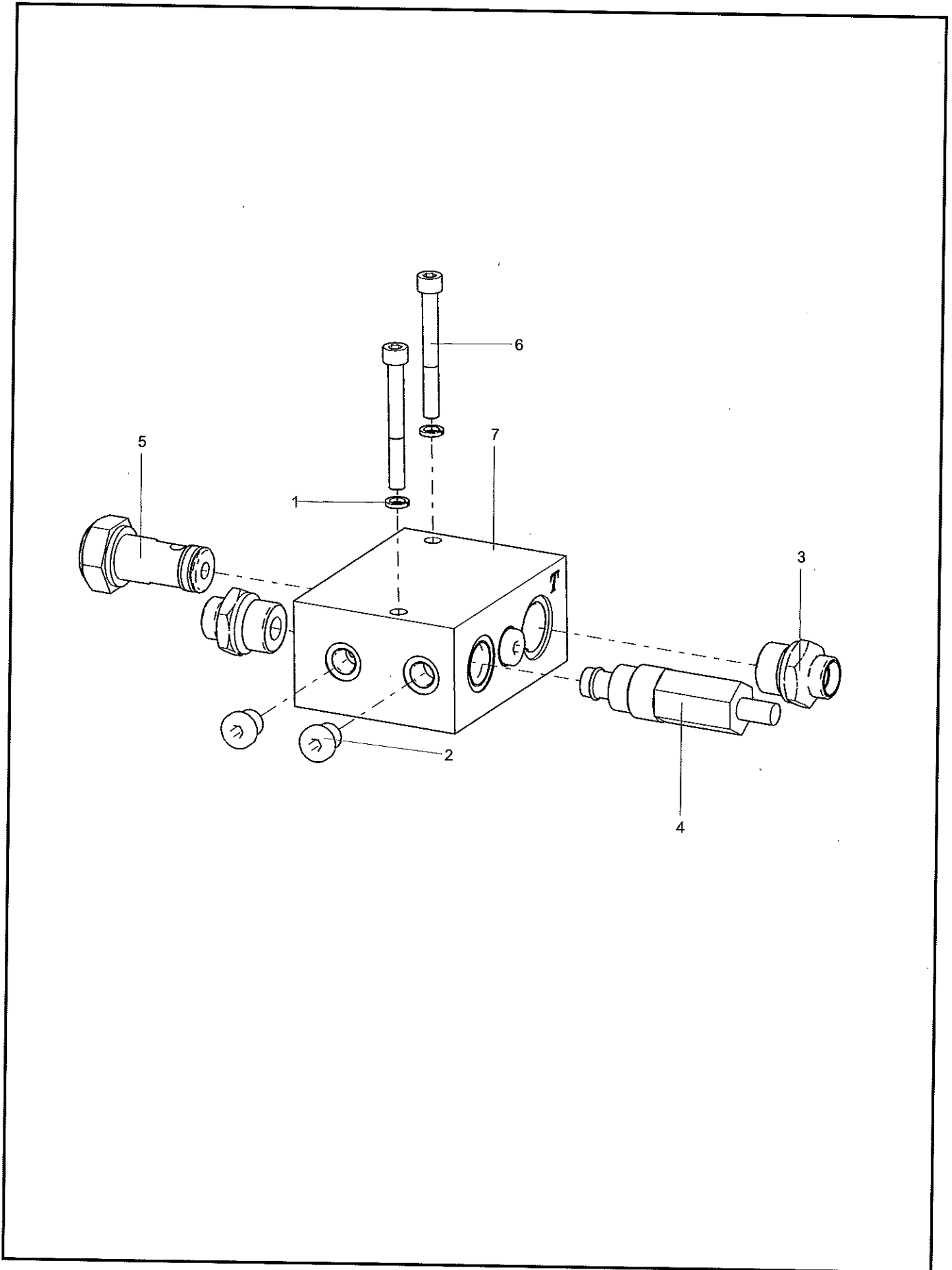

INDEX	PART NO.	DESCRIPTION	QTY	SEE PAGE
1	A210401000017	Washer	2	
2	B210780000201	Screw Plug	4	
3	B210780000824	Fitting, Adapter	2	
4	B220400000217	Valve, Relief	1	
5	B220401000540	Check Valve	1	
6	A210204000151	Screw	2	
7	13360514	Valve block body	1	

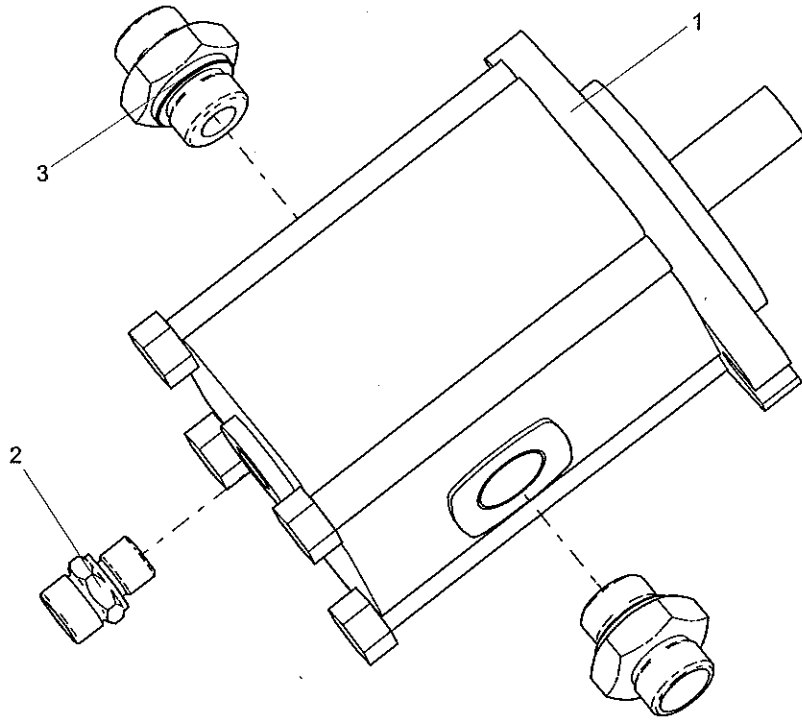



INDEX	PART NO.	DESCRIPTION	QTY	SEE PAGE
1	60283185	Gear Motor	1	
2	B21078000232	Adapter Fitting	1	
3	B21078000266	Adapter Fitting	2	

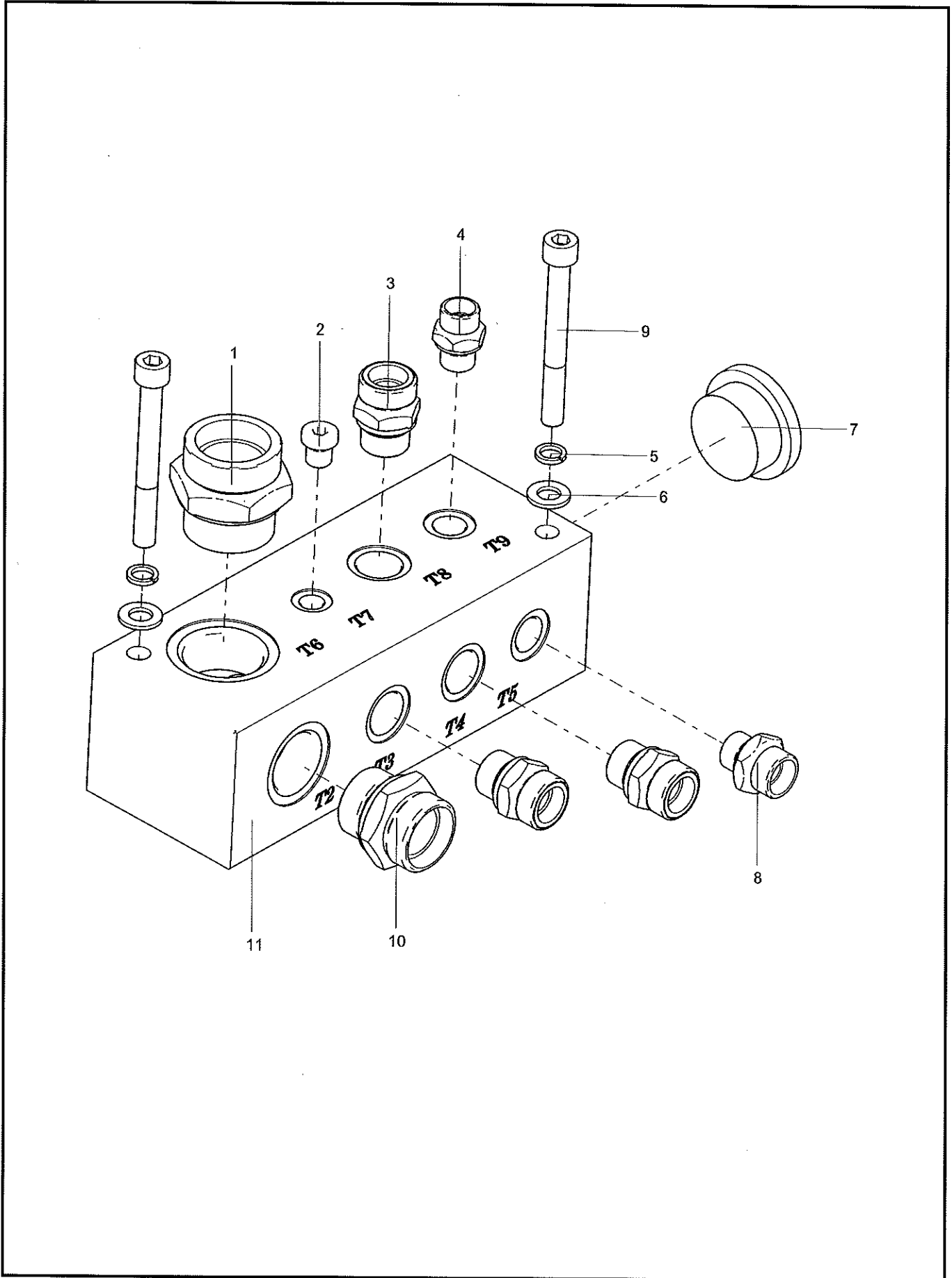

INDEX	PART NO.	DESCRIPTION	QTY	SEE PAGE
1	B210780000054	Adapter Fitting	1	
2	B210780000609	Screw Plug	1	
3	B210780000131	Adapter Fitting	3	
4	B210780000037	Adapter Fitting	1	
5	A210401000001	Washer	2	
6	A210405000011	Washer	2	
7	23000678	Screw Plug	1	
8	B210780000040	Fitting, Adapter	1	
9	A210204000017	Screw	2	
10	B210780000052	Adapter Fitting	1	
11	13915464	Oil collection block	1	

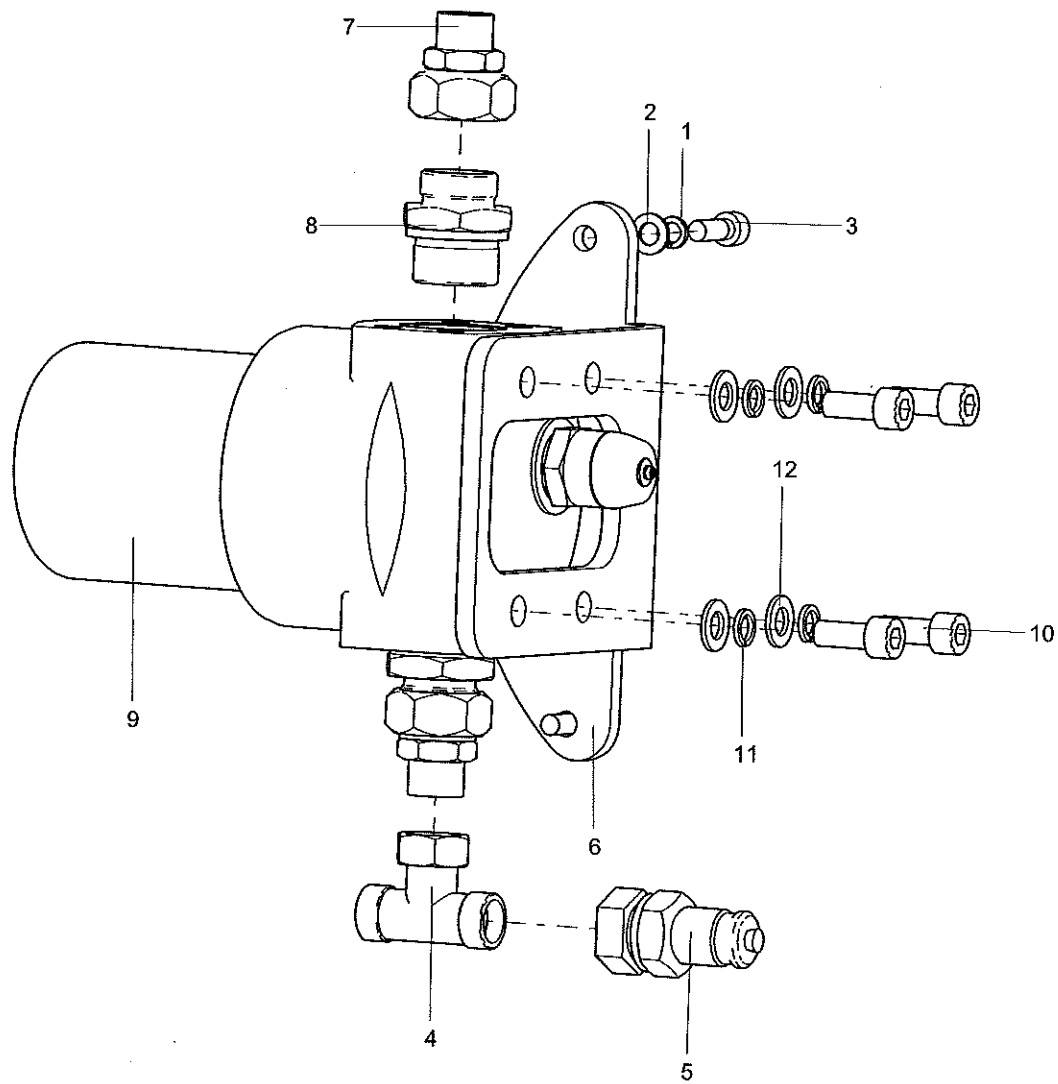

INDEX	PART NO.	DESCRIPTION	QTY	SEE PAGE
1	A210401000017	Washer	3	
2	A210405000007	Washer	3	
3	A210204000162	Screw	3	
4	B210780000413	Tee Joint	1	
5	151207000029B	Pressure-measuring Connector	1	
6	14208716	Filter supporting board	1	
7	B210780000070	Fitting	2	
8	60229226	End straight joint	2	
9	60260271	High Pressure Filter	1	
10	A210204000161	Screw	4	
11	A210401000001	Washer	4	
12	A210405000011	Washer	4	

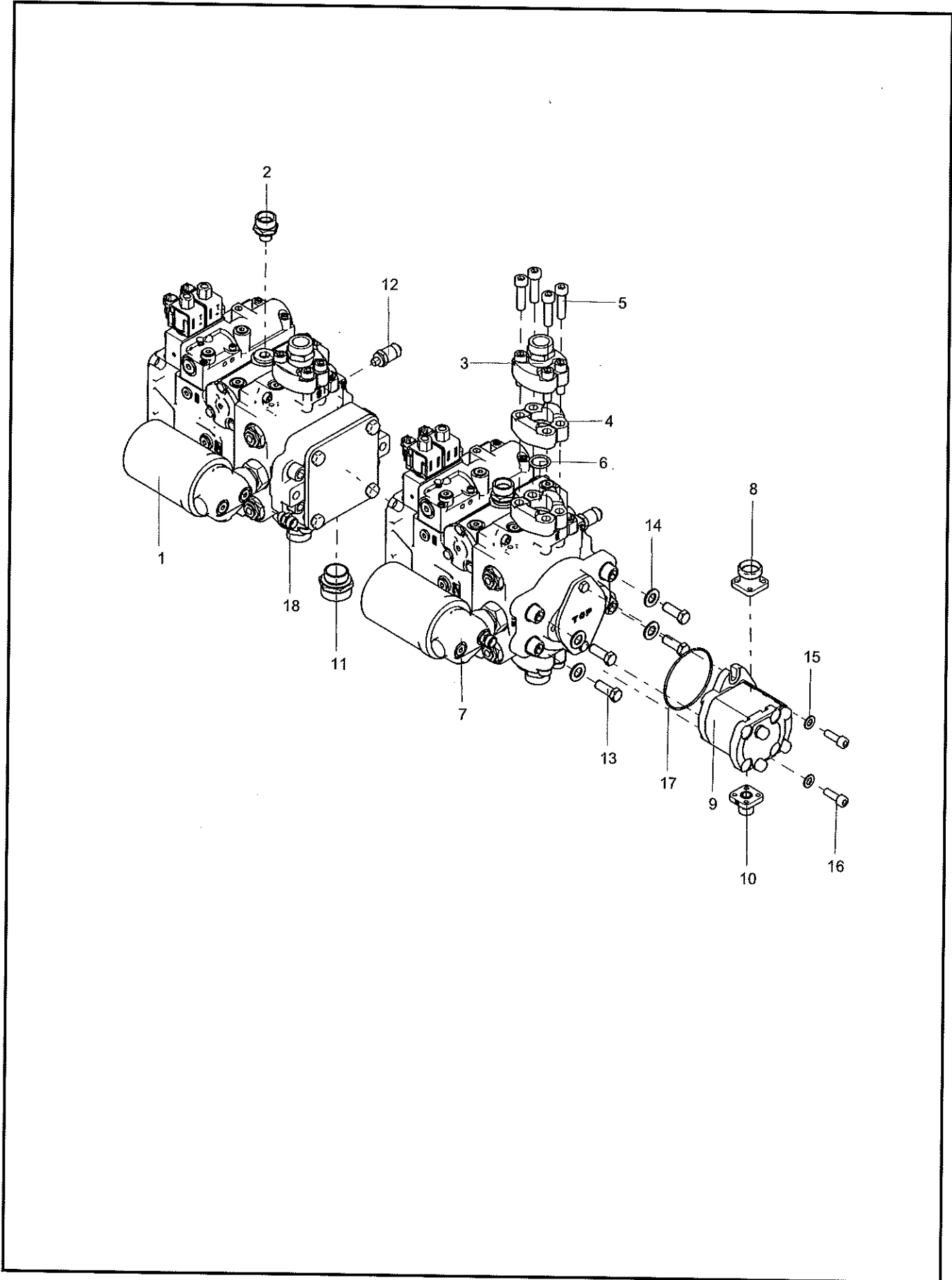

INDEX	PART NO.	DESCRIPTION	QTY	SEE PAGE
1	150102030013A	Plunger Pump	1	
2	B210780000107	End Through Adapter	2	
3	B210780000059	Fitting, Elbow	4	
4	B210780000004	Split Flange	8	
5	B210299000026	Screw	16	
6	A210609000038	O-ring	4	
7	150102030012A	Plunger Pump	1	
8	B210780000008	Square Flange Joint	1	
9	60277744	External-meshing Gear Pump	1	
10	B210780000009	Square Flange Joint	1	
11	B210780000671	End Through Adapter	2	
12	B210780001175	Pressure-measuring Connector	4	
13	A229900009970	Bolt	8	
14	B210299000005	Screw	2	
15	A210405000002	Washer	8	
16	A210405000011	Washer	2	
17	B230101000960	O-ring	1	
18	B210780000898	End Through Adapter	2	

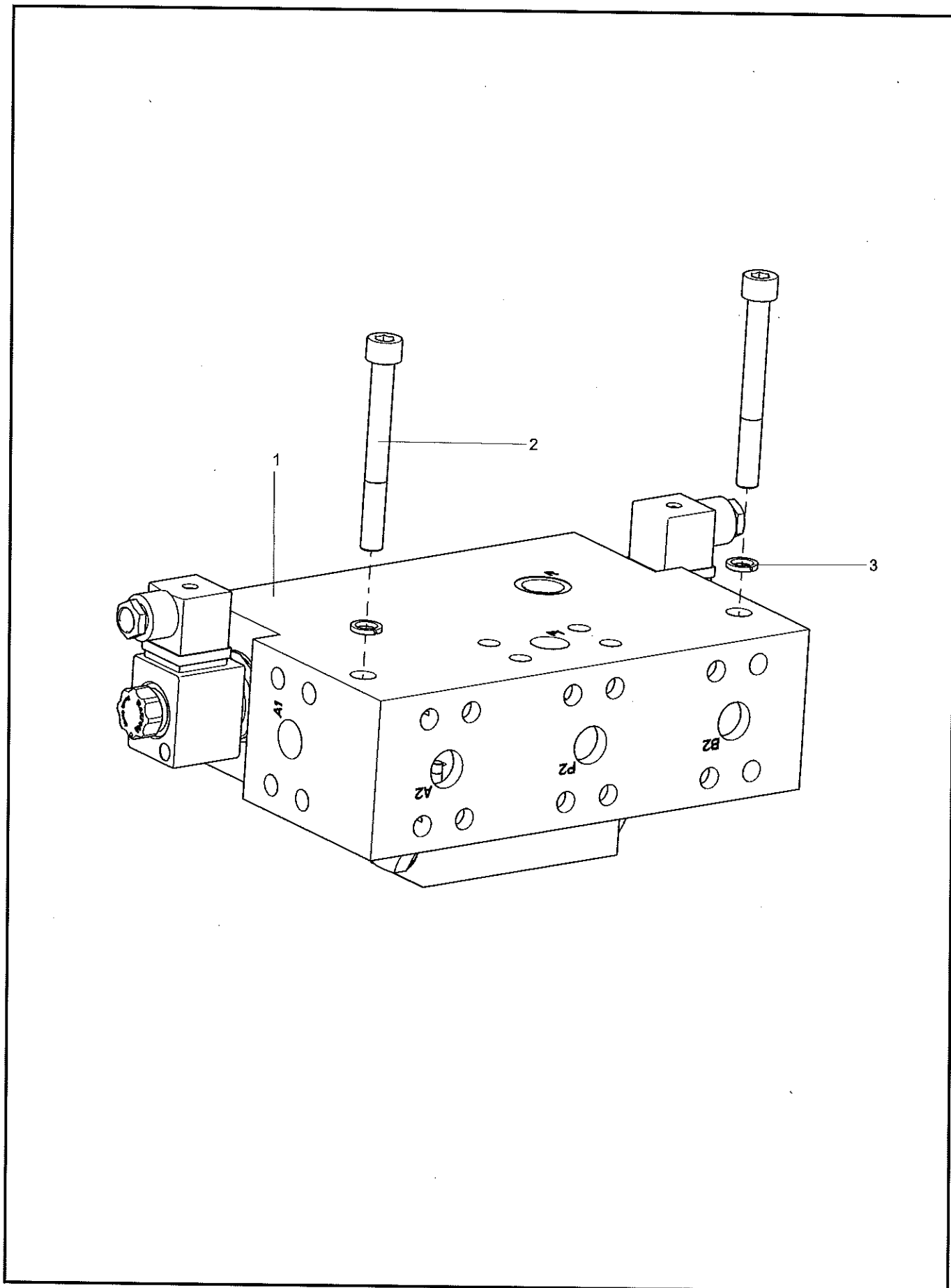



INDEX	PART NO.	DESCRIPTION	QTY	SEE PAGE
1	A810201060028	Vibration Switch Valve	1	
2	A210204000017	Screw	2	
3	A210401000001	Washer	2	

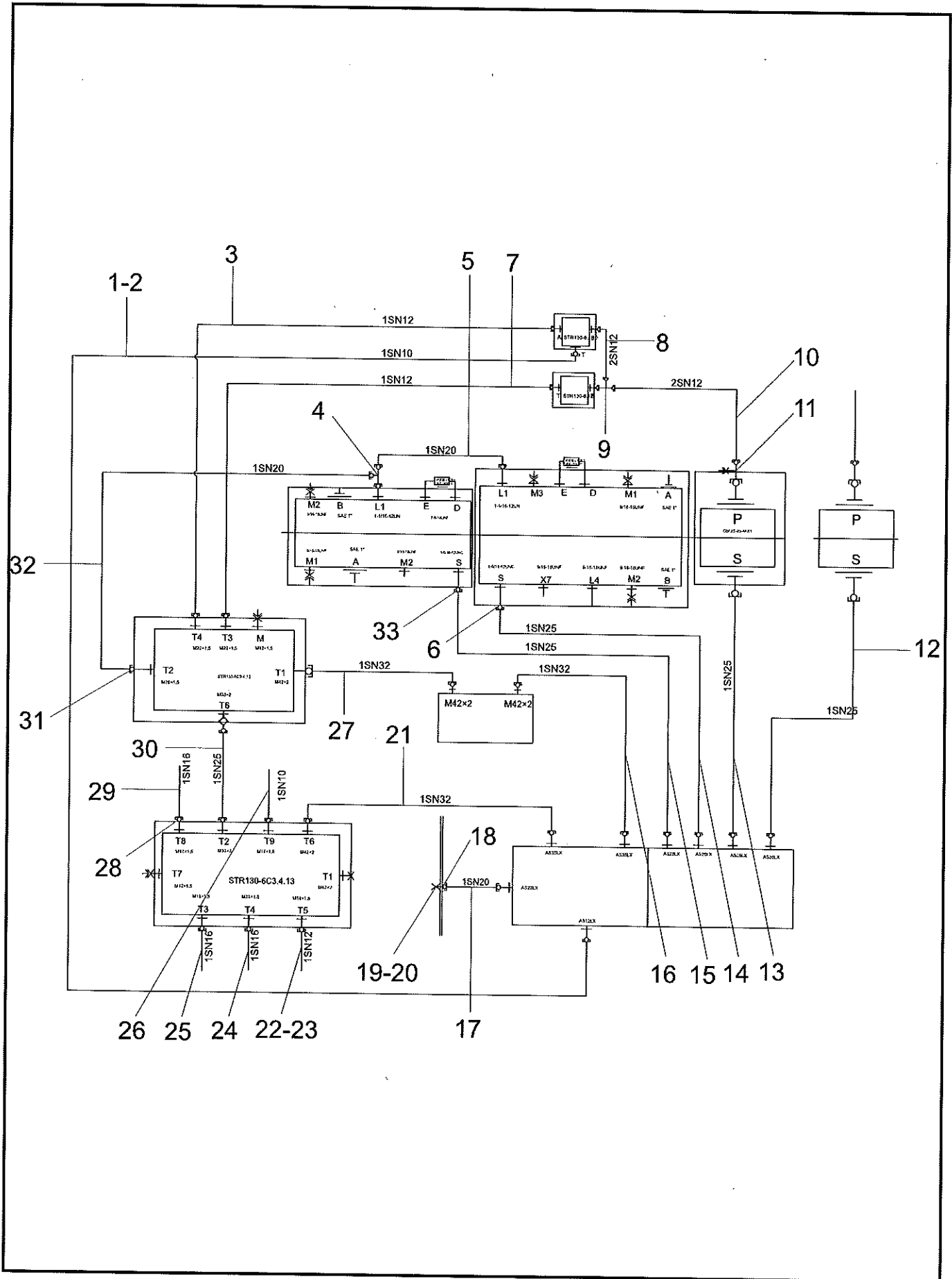

INDEX	PART NO.	DESCRIPTION	QTY	SEE PAGE
1	B230103001057	Rubber Hose	1	
2	A229900003852	Clip	1	
3	21021877	Hose	1	
4	B210780000018	Tee Joint	1	
5	B230103000869	Hose Assembly	1	
6	B210780000838	Elbow Fitting	3	
7	B230103000059	Hose	1	
8	21011473	Rubber Hose	1	
9	B210780000017	Tee Joint	3	
10	B230103000137	Rubber Hose	1	
11	151207000029B	Pressure-measuring Connector	1	
12	B230103006189	Rubber Hose	1	
13	B230103006405	Rubber Hose	1	
14	B230103000066	Hose	2	
15	B230103002218	Rubber Hose	1	
16	B230103005096	Rubber Hose	1	
17	151007060002	Rubber Hose Assembly	1	
18	B210780000685	Baffle Adapter	1	
19	B210334000010	Nut	1	
20	21023547	Screw plug	1	
21	60332213	rubber hose	1	
22	B230103004287	Rubber Hose	1	
23	B210780001396	Pipe connector	1	
24	B230103004027	Hose	1	
25	60034759	Rubber Hose	1	
26	B230103005873	Rubber Hose	1	
27	B230103002298	Rubber hose	1	
28	60165875	Pipe Adapter	2	
29	21020350	Rubber Hose	1	
30	23001025	Rubber Hose	1	
31	B210780000028	Elbow Fitting	1	
32	B230103001113	Hose	1	
33	B210780000186	End Straight Adapter	2	

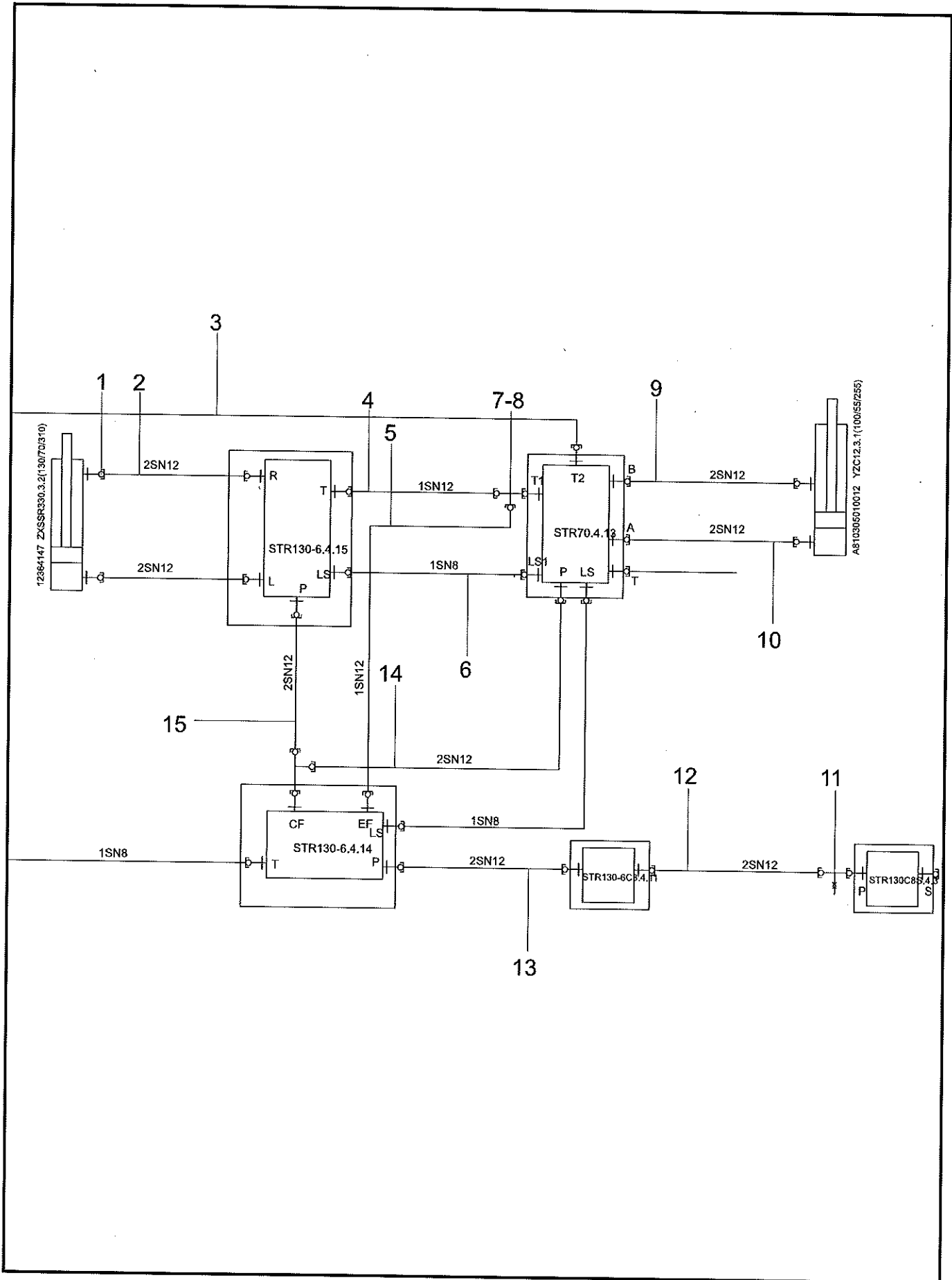

INDEX	PART NO.	DESCRIPTION	QTY	SEE PAGE
1	B210780000266	Adapter Fitting	4	
2	B230103001629	Hose	1	
3	21003889	Hose	2	
4	B230103000295	Hose	1	
5	B230103000779	Rubber Hose	1	
6	21032394	Rubber Hose	1	
7	B210780000017	Tee Joint	3	
8	B210780000025	Elbow Fitting	5	
9	60127341	Hose	1	
10	13112771	Hose	1	
11	151207000029B	Pressure-measuring Connector	1	
12	B230103000345	Hose Assembly	1	
13	B230103007175	Hose Assembly	1	
14	60008237	Rubber Hose	1	
15	B230103001881	Rubber Hose	1	

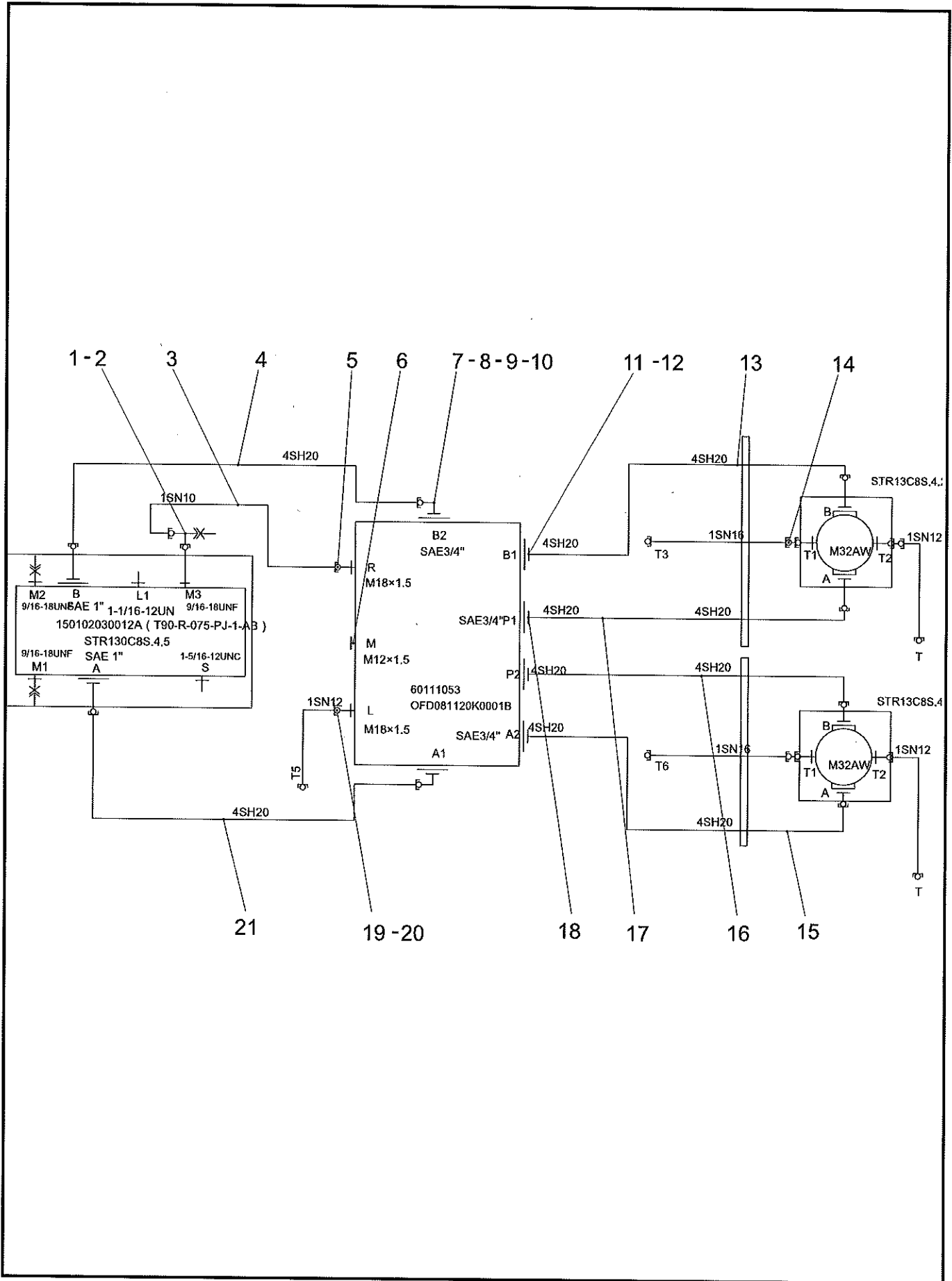

INDEX	PART NO.	DESCRIPTION	QTY	SEE PAGE
1	B210780000019	Tee Joint	1	
2	151207000031B	Pressure-measuring Connector	1	
3	B230103000712	Hose	1	
4	B230103001790	Rubber Hose	1	
5	B210780000228	Adapter Fitting	1	
6	B210780000609	Screw Plug	1	
7	A210609000038	O-ring	6	
8	B210780000007	Split Flange	12	
9	A210204000215	Screw	24	
10	A229900002752	Fitting, Elbow	2	
11	B210780000029	Elbow Fitting	1	
12	B210780000056	Flange Connection	4	
13	60065473	Rubber Hose	1	
14	B210780001310	Elbow Fitting	2	
15	60345453	rubber hose	1	
16	60207510	rubber hose	1	
17	151007260304B	Hose Assembly	1	
18	60202197	Pipe connector	1	
19	B210780000025	Elbow Fitting	1	
20	B210780000040	Fitting, Adapter	1	
21	60345452	rubber hose	1	

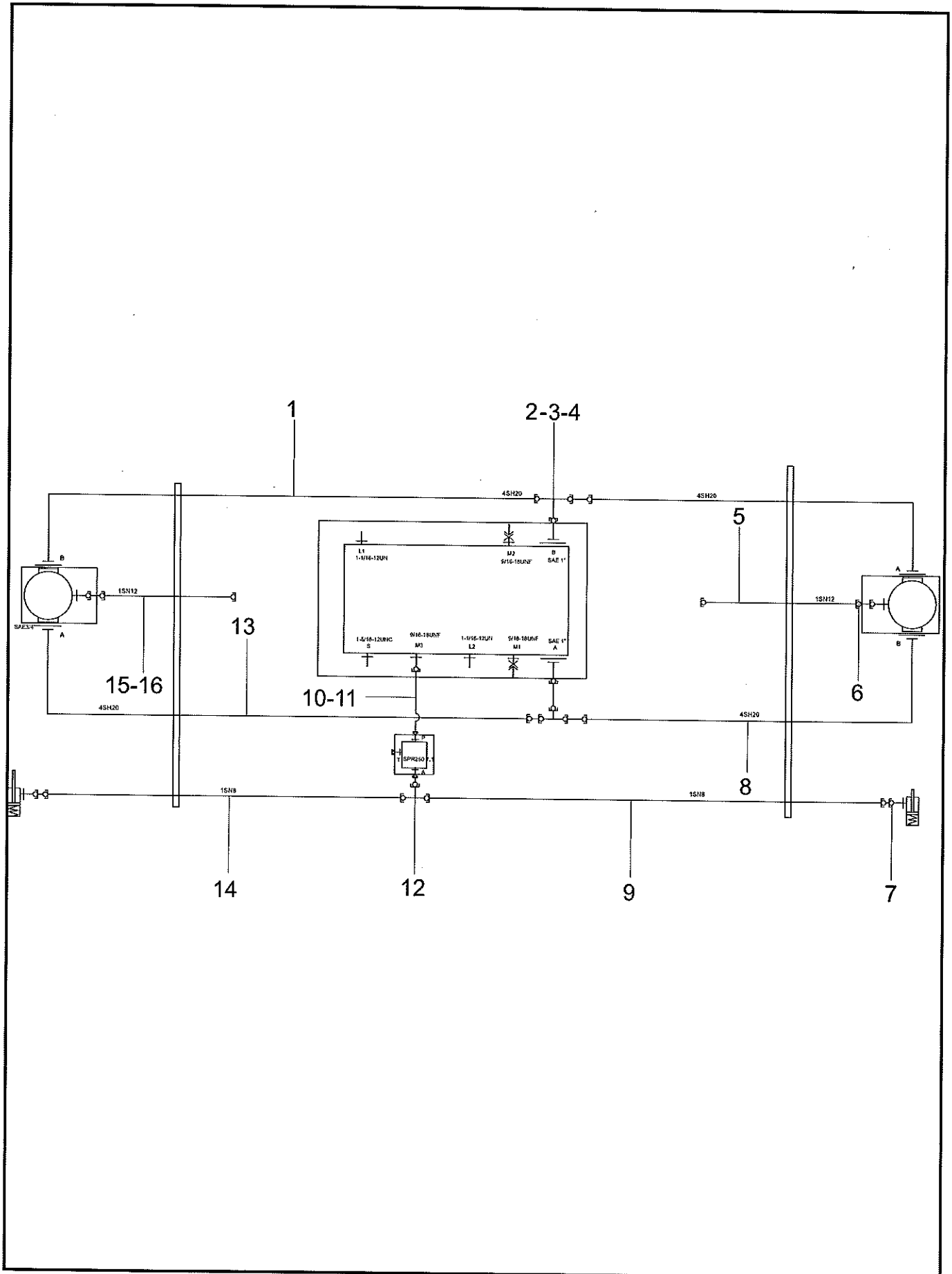



INDEX	PART NO.	DESCRIPTION	QTY	SEE PAGE
1	B230103005108	Rubber Hose	1	
2	B210780000021	Tee Joint	2	
3	60202197	Pipe connector	1	
4	B210780000029	Elbow Fitting	3	
5	B230103007493	Rubber Hose	1	
6	151399000452A	protective sleeve	1	
7	B210780000636	Elbow Fitting	3	
8	151007260233A	Rubber Hose Assembly	2	
9	B230103006274	Rubber Hose	1	
10	B230103001352	Rubber Hose	1	
11	B210780000829	Adapter Fitting	1	
12	B210780000631	Tee Joint	1	
13	B230103005107	Rubber Hose 4SH20-DKOS-SFS90-3850	1	
14	B230103006195	Hose Assembly	1	
15	151005110049A	Rubber hose assembly	1	
16	A229900003852	Clip	4	

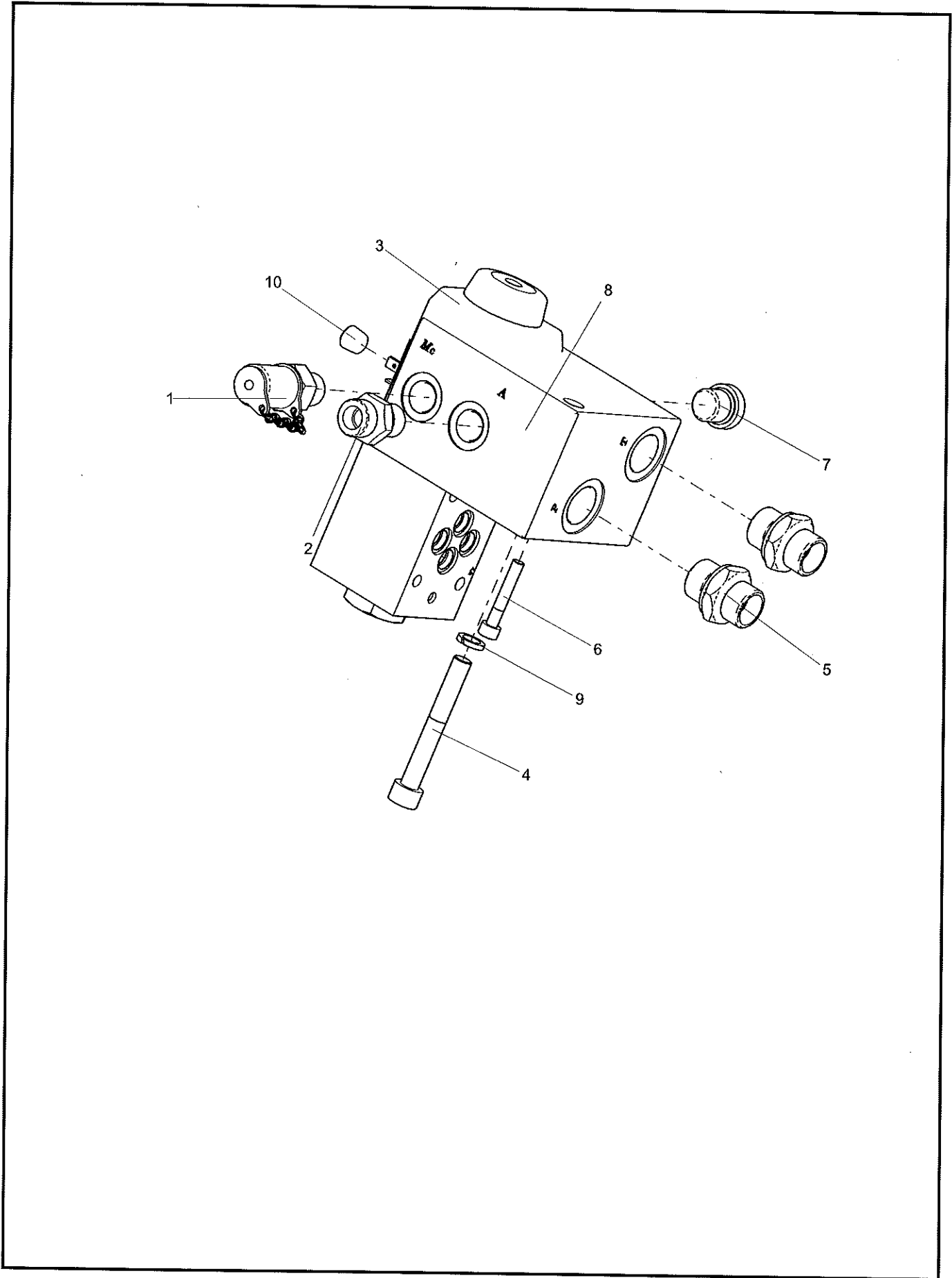

INDEX	PART NO.	DESCRIPTION	QTY	SEE PAGE
1	60016447	Pressure-measuring Fitting	1	
2	B210780000036	Adapter Fitting	1	
3	B220400000079	Directional Solenoid Valve	1	
4	A210204000342	Screw	2	
5	B210780000228	Adapter Fitting	2	
6	A210204000119	Screw	4	
7	B210780000201	Screw Plug	1	
8	A820101342410	Control Valve Body	1	
9	A210401000017	Washer	2	
10	60005842	Plug Screw	1	

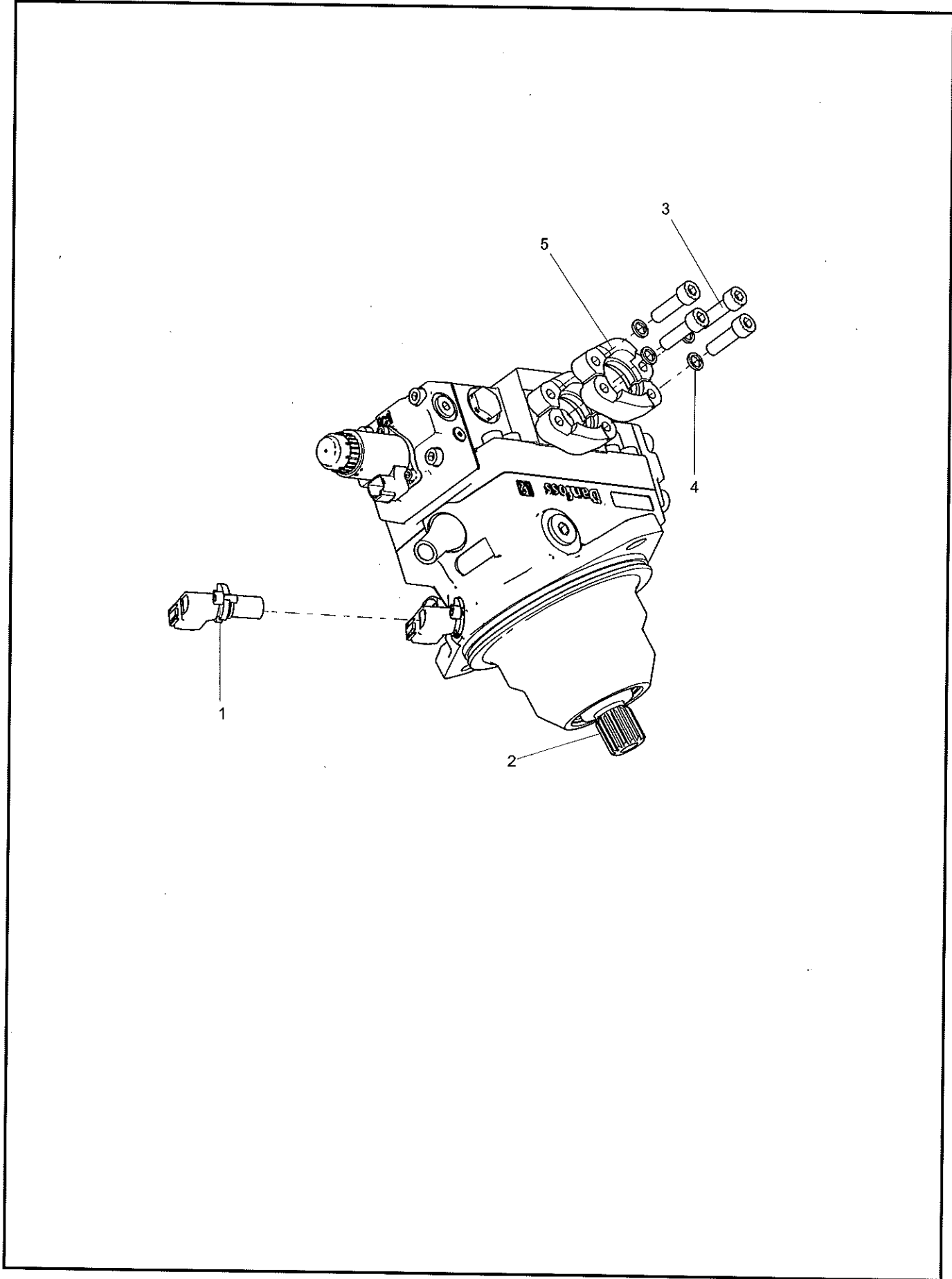

INDEX	PART NO.	DESCRIPTION	QTY	SEE PAGE
1	60220963	Speed Sensor	1	
2	150202040038B	Plunger Motor	1	
3	A210204000215	Screw	8	
4	A210401000001	Washer	8	
5	B210780000007	Split Flange	4	

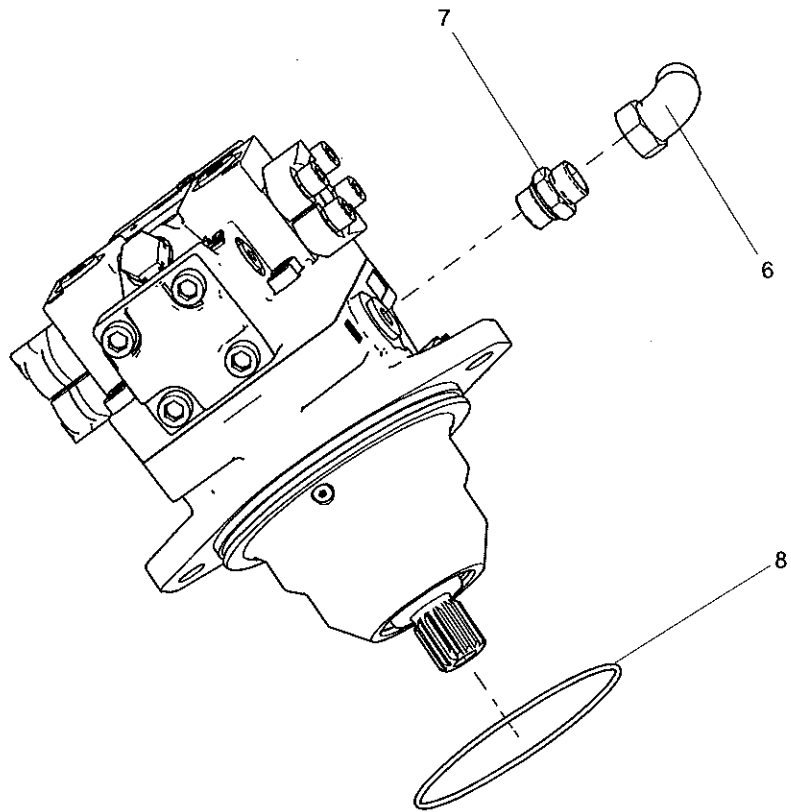

INDEX	PART NO.	DESCRIPTION	QTY	SEE PAGE
6	B210780000025	Elbow Fitting	1	
7	B210780000587	Adapter Fitting	1	
8	B230101000461	O-ring	1	

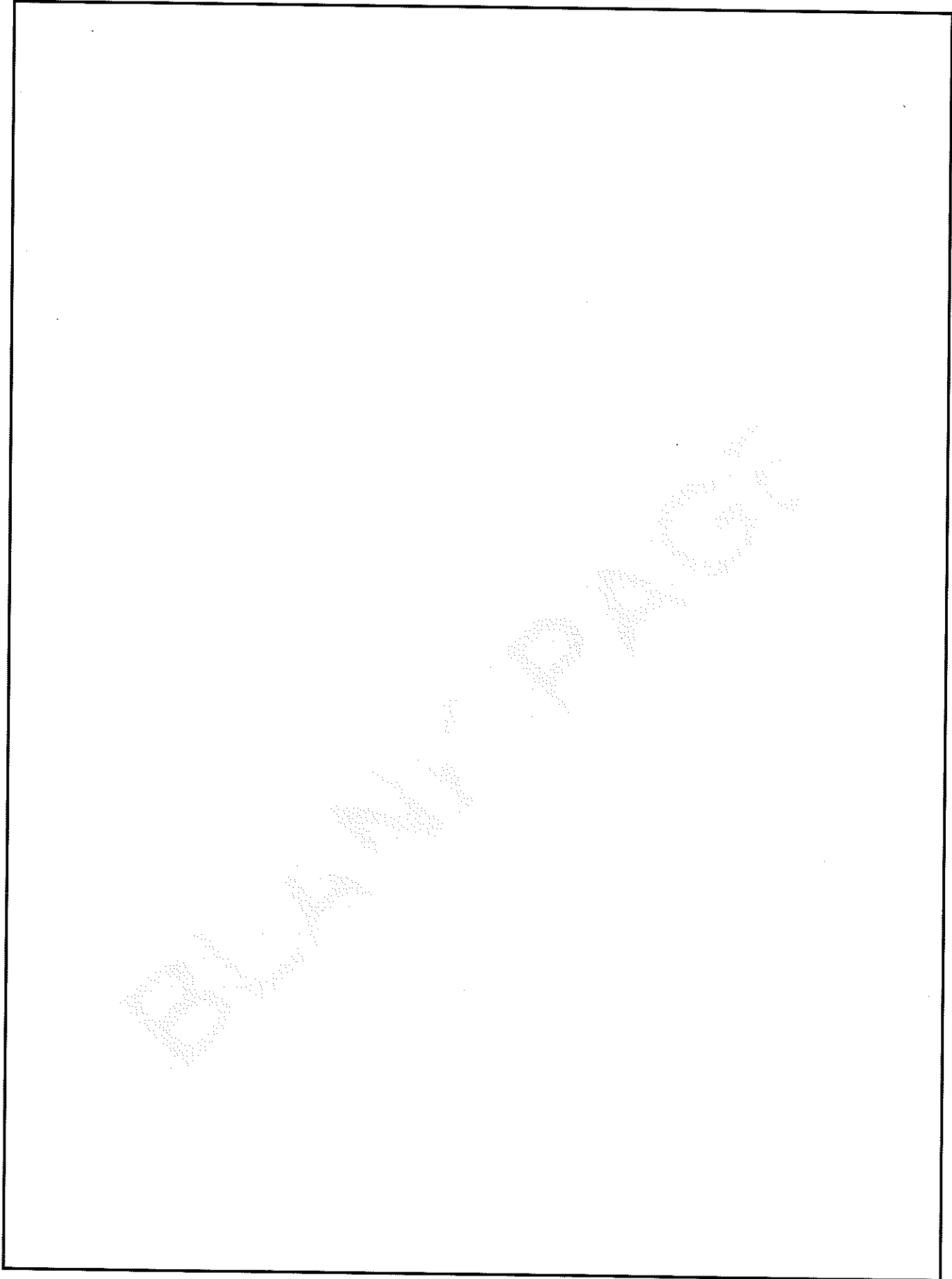



**Group 9**  
**covering parts**

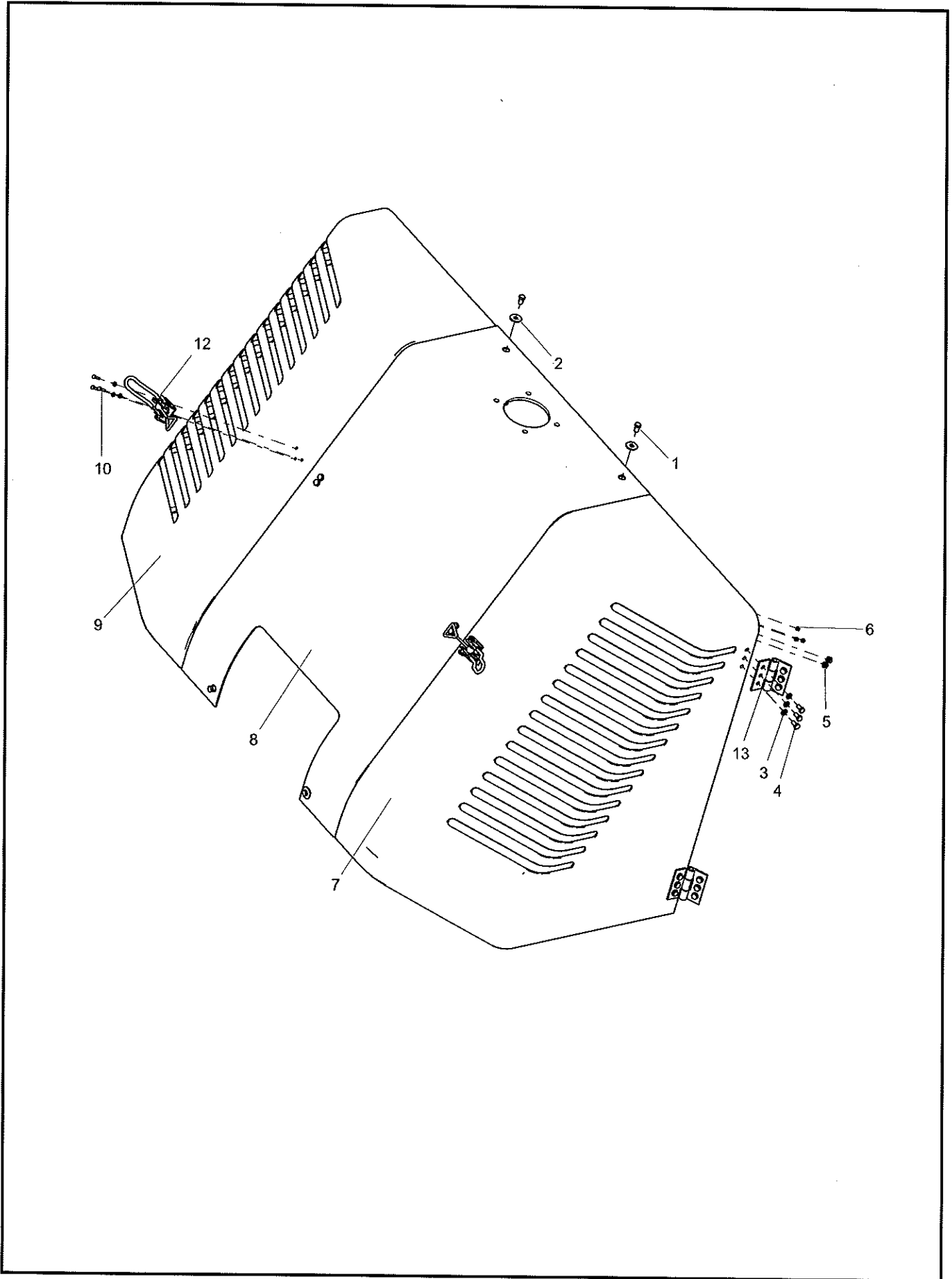

INDEX	PART NO.	DESCRIPTION	QTY	SEE PAGE
1	A210111000125	Bolt	4	
2	A210404000003	Washer	4	
3	A210891000007	Hinge	4	
4	A210111000088	Bolt	28	
5	A210307000012	Nut	4	
6	A210307000015	Nut	6	
7	YLJ004727975	left covering parts	1	
8	YLJ004728021	Covered in a	1	
9	YLJ005110630	Corver	1	
10	A210111000071	Bolt	6	
11	A210405000005	Washer	6	
12	60031250	Tool hasp	2	
13	A210405000007	Washer	28	

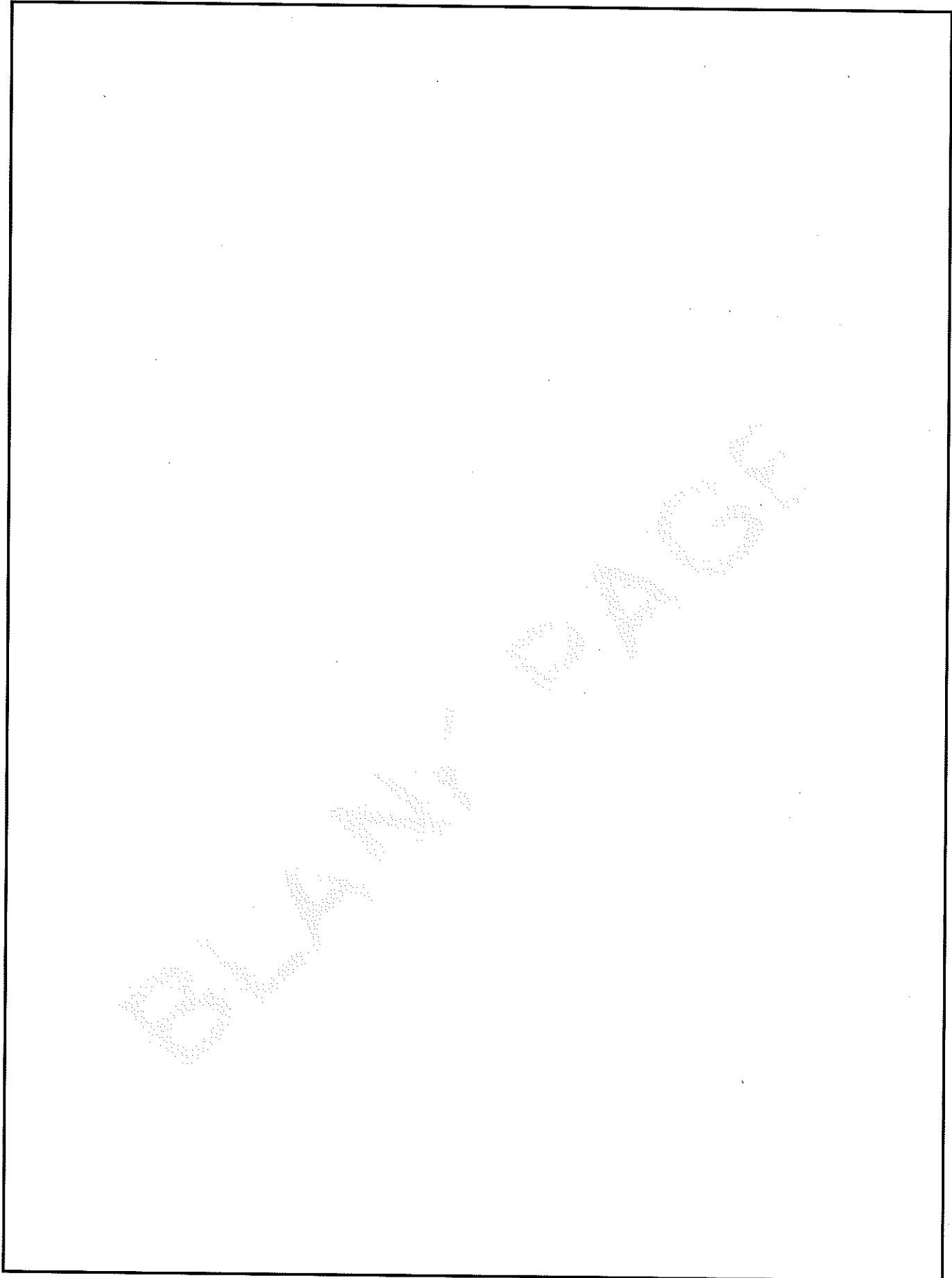

Group 10

rear frame

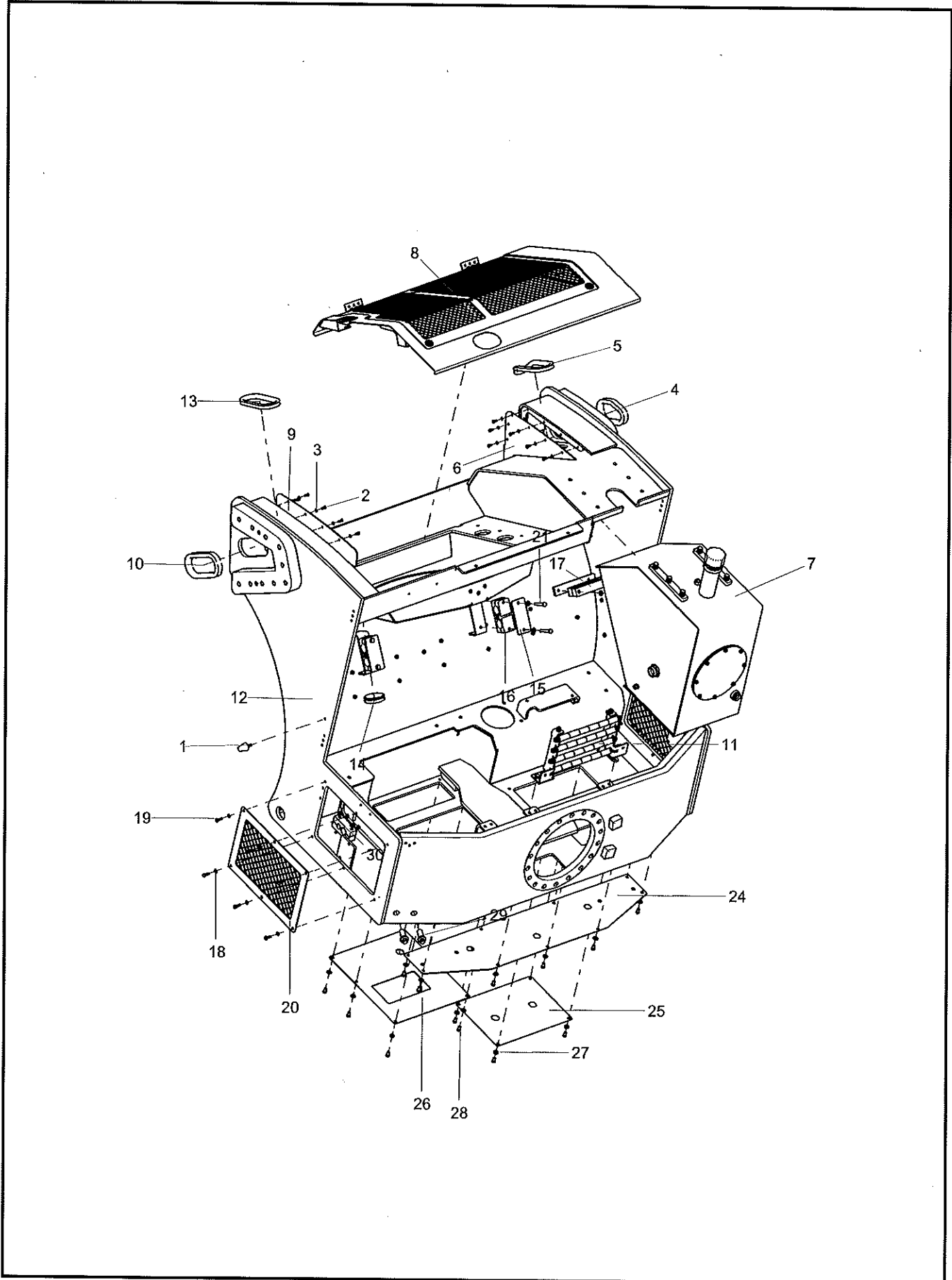

INDEX	PART NO.	DESCRIPTION	QTY	SEE PAGE
1	11104119	Damping bearer	2	
2	A210111000079	Bolt	12	
3	A210405000006	Washer	12	
4	14309077	Rubber retainer	1	
5	14529231	Rubber retainer	1	
6	14396915	Cover plate	1	
7	14510385	oil tank	1	10-6
8	YLJ005101815	air intake hood	1	
9	14396902	Cover plate	1	
10	14523445	Rubber retainer	1	
11	YLJ005393615	hose clip unit	1	
12	YLJ005103707	rear carriage weld assem	1	
13	14524432	Rubber retainer	1	
14	14309087	Ring	1	
15	10994336	Cover Board, Tube Clamp	2	
16	12884288	Tube Clamp	4	
17	YLJ005337392	Clip	1	
18	A210405000007	Washer	12	
19	A210111000090	Bolt	12	
20	13979898	Net plate	2	
21	A210111000032	Bolt	14	
22	YLJ005337594	Clip	1	
23	YLJ005337130	Clip	2	
24	13920581	cover plate	1	
25	13689696	cover plate	1	
26	YLJ005770629	cover plate	1	
27	A210405000011	Washer	31	
28	A210111000125	Bolt	17	
29	A820205001562	Spacer Plate Joint	2	
30	YLJ005337280	Clip	1	

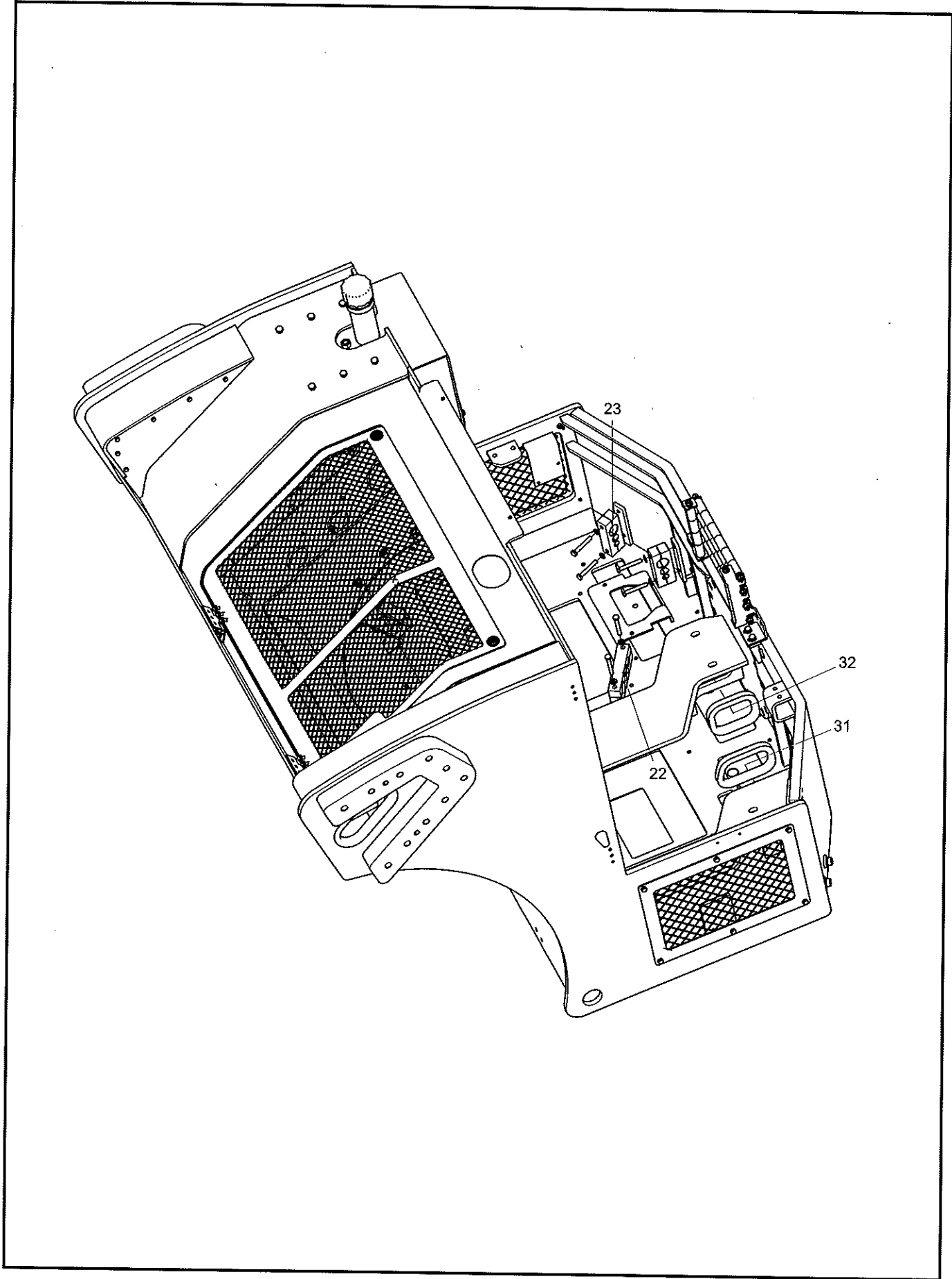



INDEX	PART NO.	DESCRIPTION	QTY	SEE PAGE
22	YLJ005337594	Clip	1	
23	YLJ005337130	Clip	2	
31	YLJ005619004	rubber retainer	1	
32	YLJ005619017	rubber retainer	2	

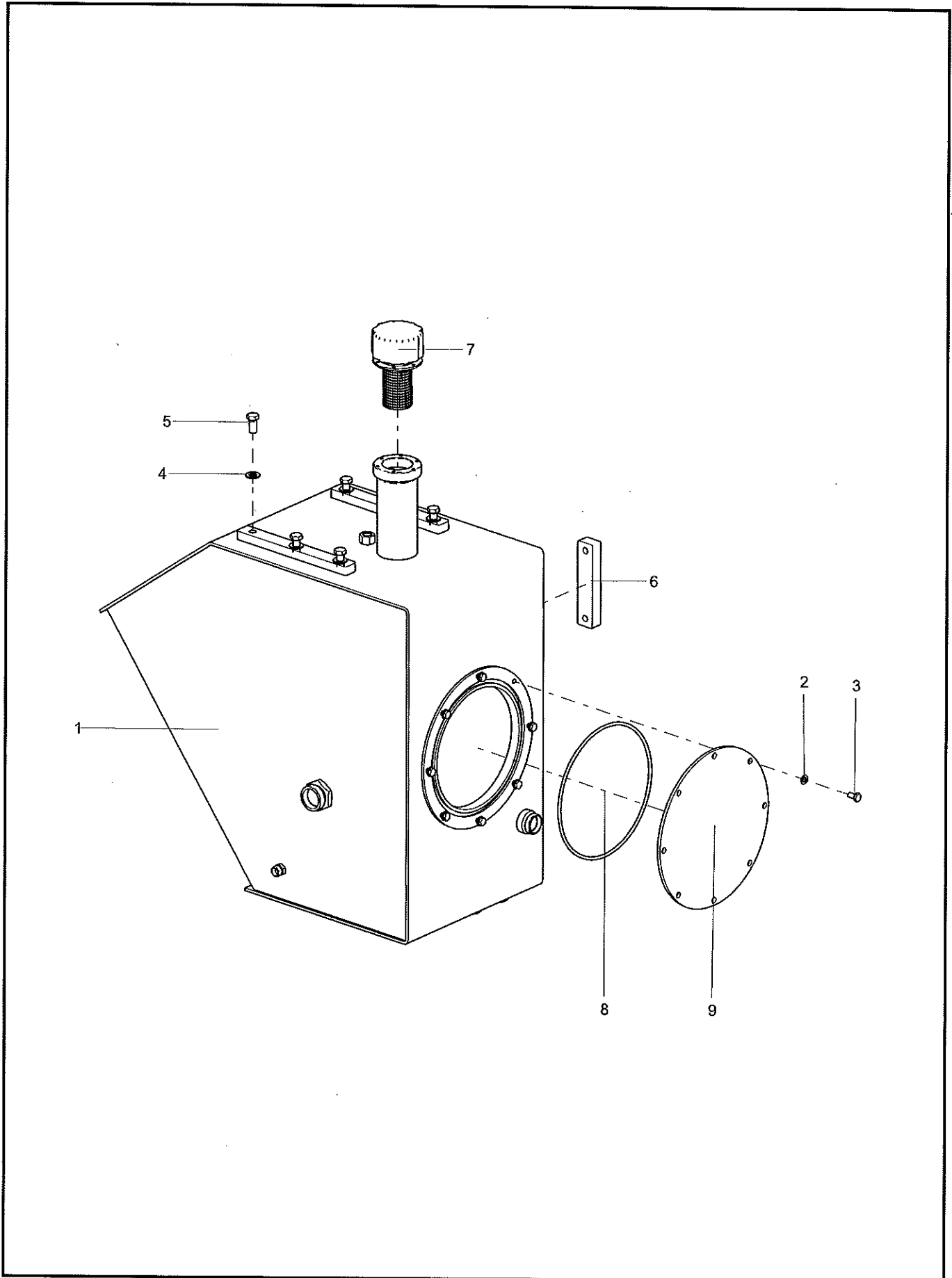

INDEX	PART NO.	DESCRIPTION	QTY	SEE PAGE
1	14510370	hydraulic fuel tank welding assy	1	
2	A210405000007	Washer	8	
3	A210111000088	Bolt	8	
4	A210405000001	Washer	6	
5	A210111000037	Bolt	6	
6	A250100000043	Liquid Level Meter	1	
7	A222100000044	Air Filter	1	
8	A210609000035	O-ring	1	
9	10245100	Cover Plate, Flange, Oil Tank	1	

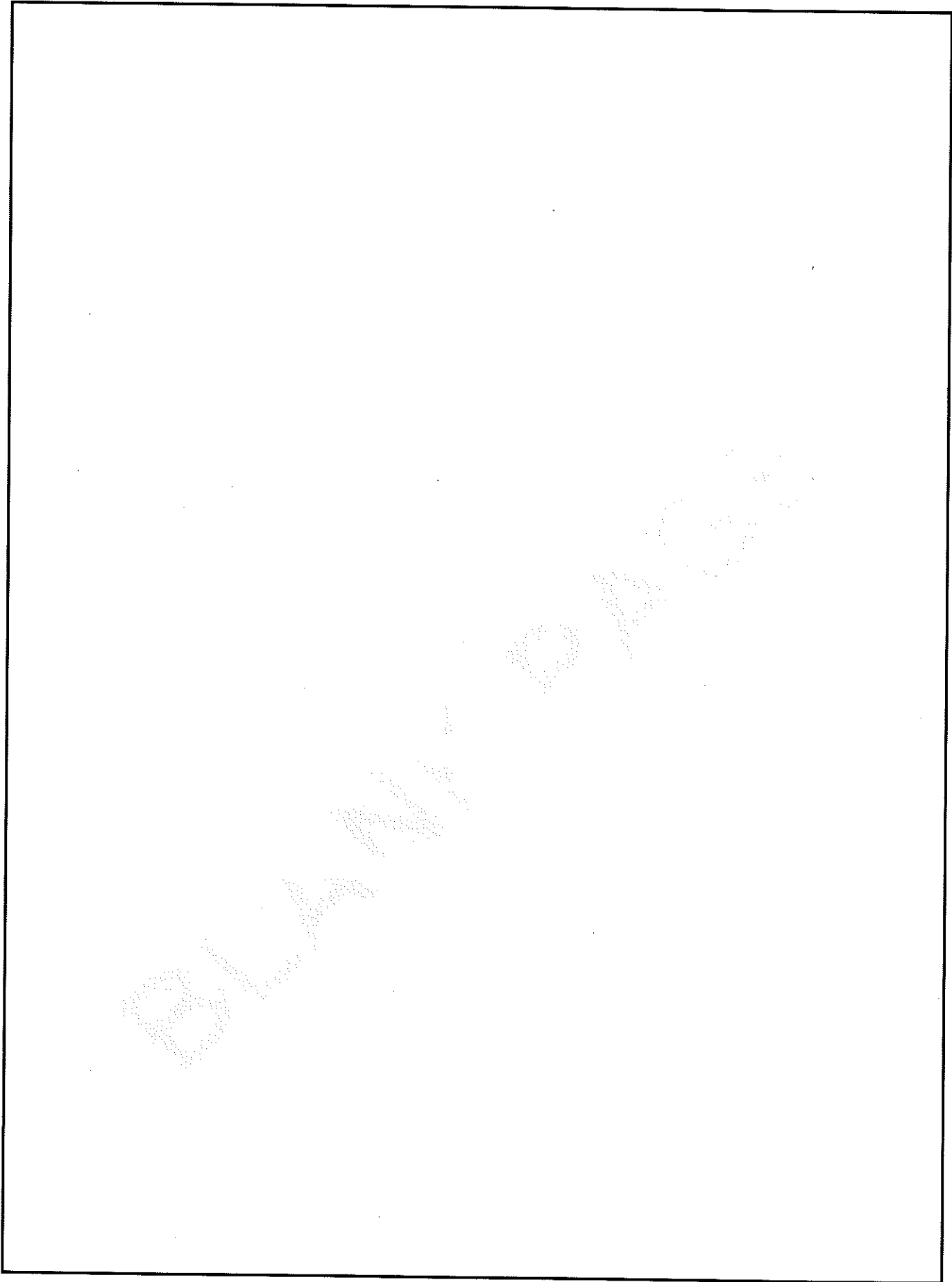

# Group 11

## Bridging BeamComponent

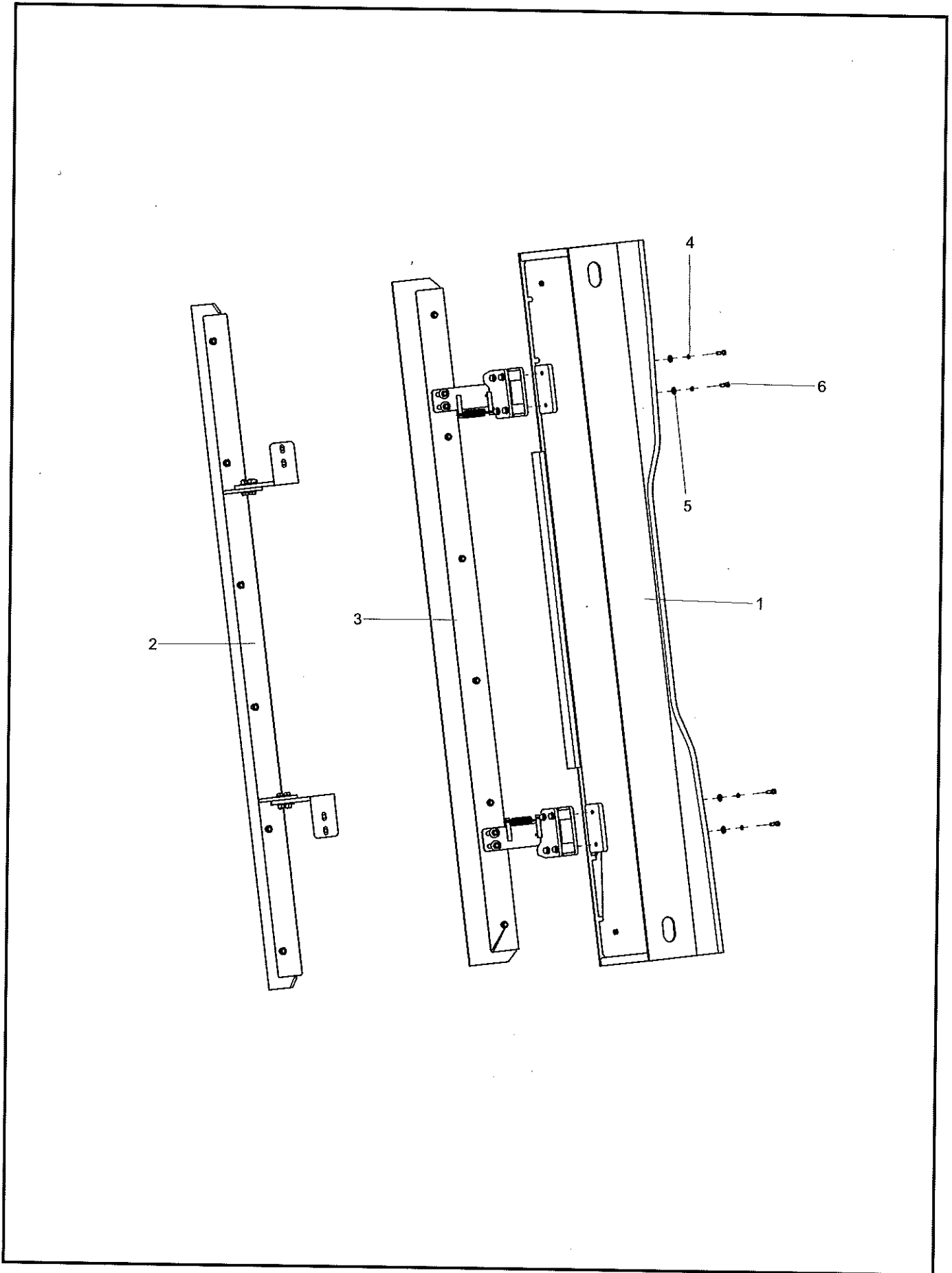

INDEX	PART NO.	DESCRIPTION	QTY	SEE PAGE
1	YLJ006045976	Cross beam welding	1	
2	13687649	Under scraper assem	1	11-4
3	YLJ005652578	Upper scraper assem.	1	11-6
4	A210401000017	Washer	4	
5	A210405000011	Washer	4	
6	A210204000347	Screw	4	

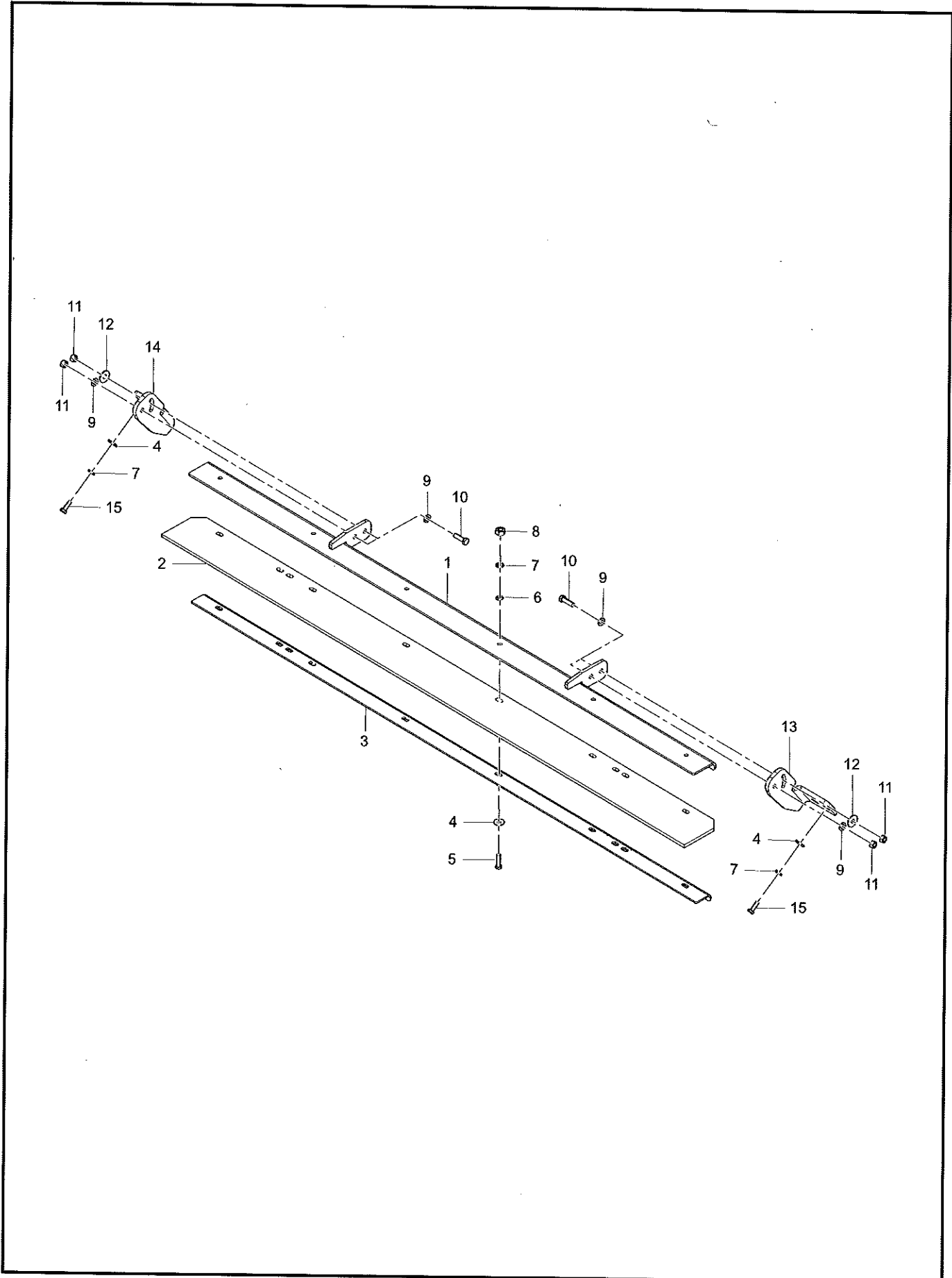



INDEX	PART NO.	DESCRIPTION	QTY	SEE PAGE
1	13687111	Supporting plate welding	1	
2	13687079	Scraper	1	
3	13687080	Pressure plate	1	
4	A210404000003	Washer	10	
5	A210111000027	Bolt	6	
6	A210405000011	Washer	6	
7	A210401000001	Washer	10	
8	A210307000017	Nut	6	
9	A210405000001	Washer	6	
10	A210111000040	Bolt	4	
11	A210307000001	Nut	4	
12	A210404000004	Washer	2	
13	13687570	Support plate	1	
14	13687571	Support plate	1	
15	A210111000023	Bolt	4	

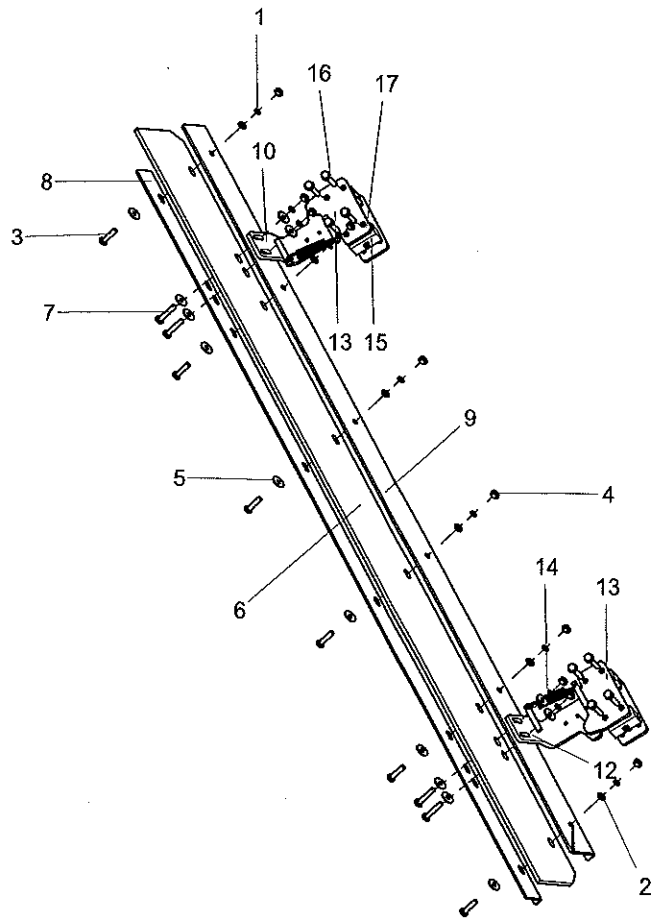

INDEX	PART NO.	DESCRIPTION	QTY	SEE PAGE
1	A210401000001	Washer	18	
2	A210405000011	Washer	14	
3	A210111000027	Bolt	6	
4	A210307000017	Nut	12	
5	A210404000003	Washer	14	
6	13687079	Scraper	1	
7	A210111000029	Bolt	6	
8	13687080	Pressure plate	1	
9	13687078	Support plate	1	
10	YLJ005567022	Scraper mounting plate	1	
11	YLJ005568451	mounting plate welding	1	
12	YLJ005568781	Scraper mounting plate	1	
13	YLJ005568841	mounting plate welding	1	
14	120801010021A	Spring	2	
15	151302010028A	Pipe Clip	4	
16	A210111000297	Bolt	8	
17	YLJ005567030	Mounting plate	2	

BLANK PAGE

Group 12

water

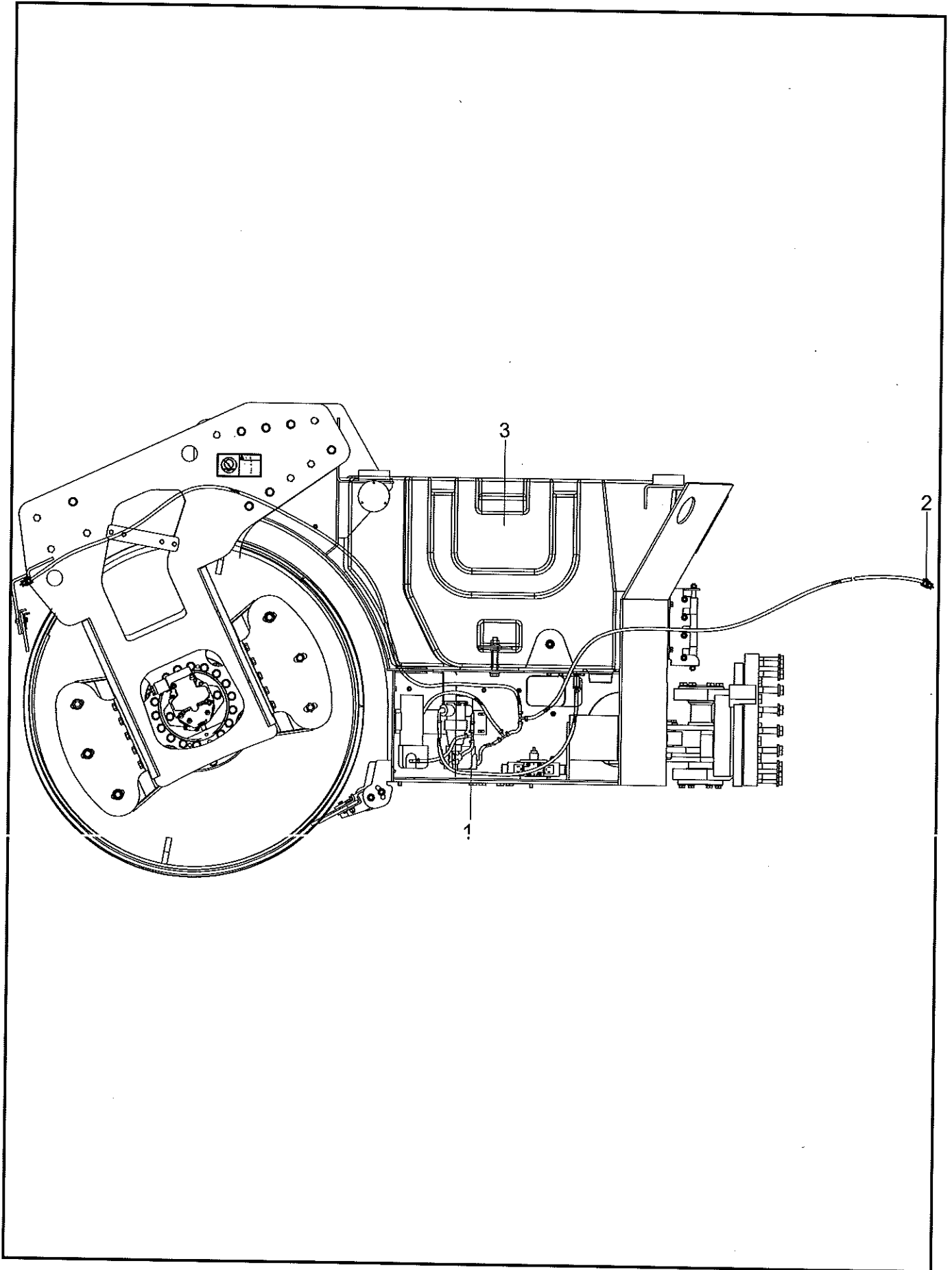

INDEX	PART NO.	DESCRIPTION	QTY	SEE PAGE
1	14323427	Outlet piping installation	1	
2	YLJ005419735	Water sprinkling tube component	2	
3	YLJ004856263	Water Tank	1	

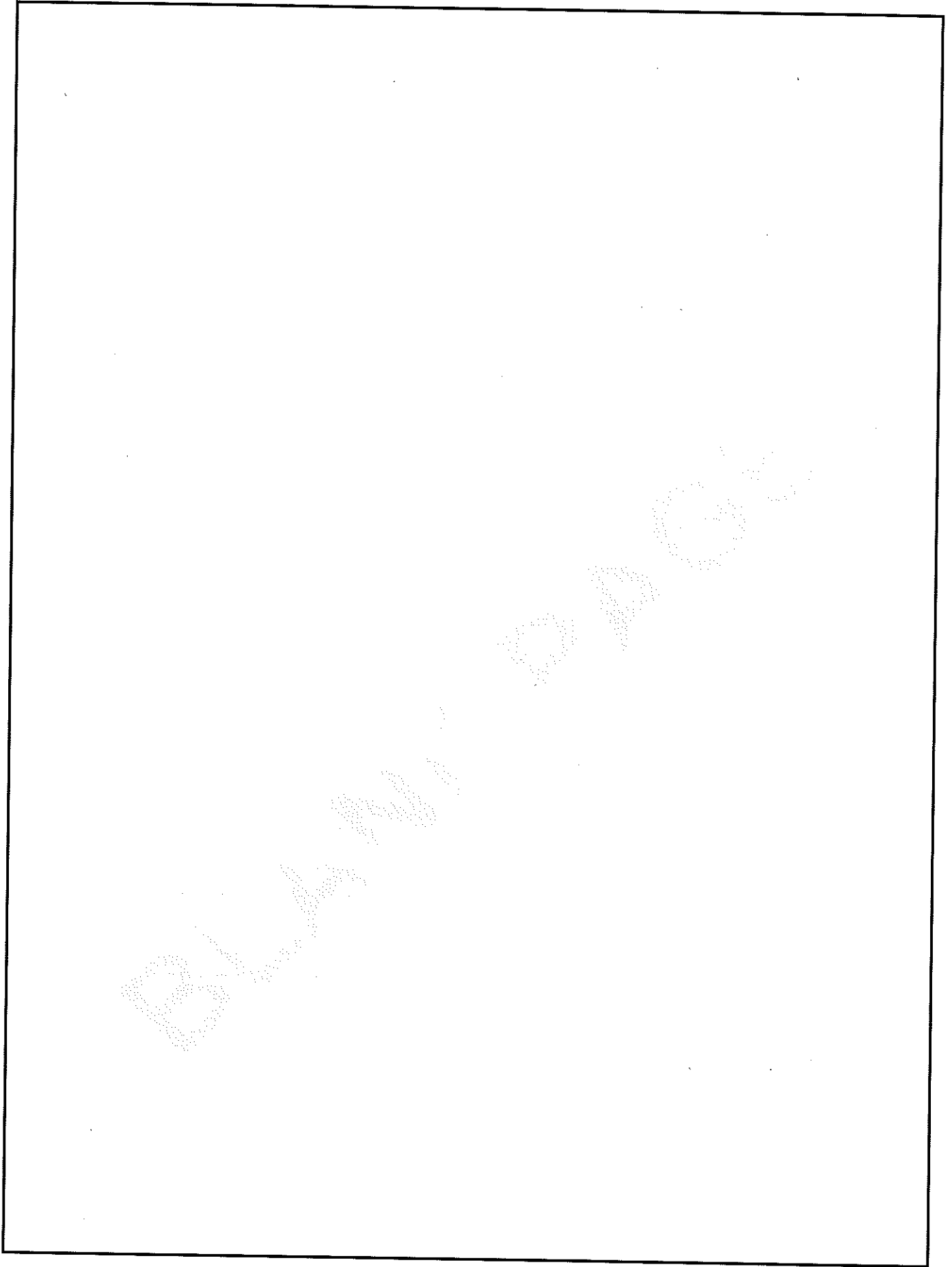



# Group 13

## Electrical system of roller

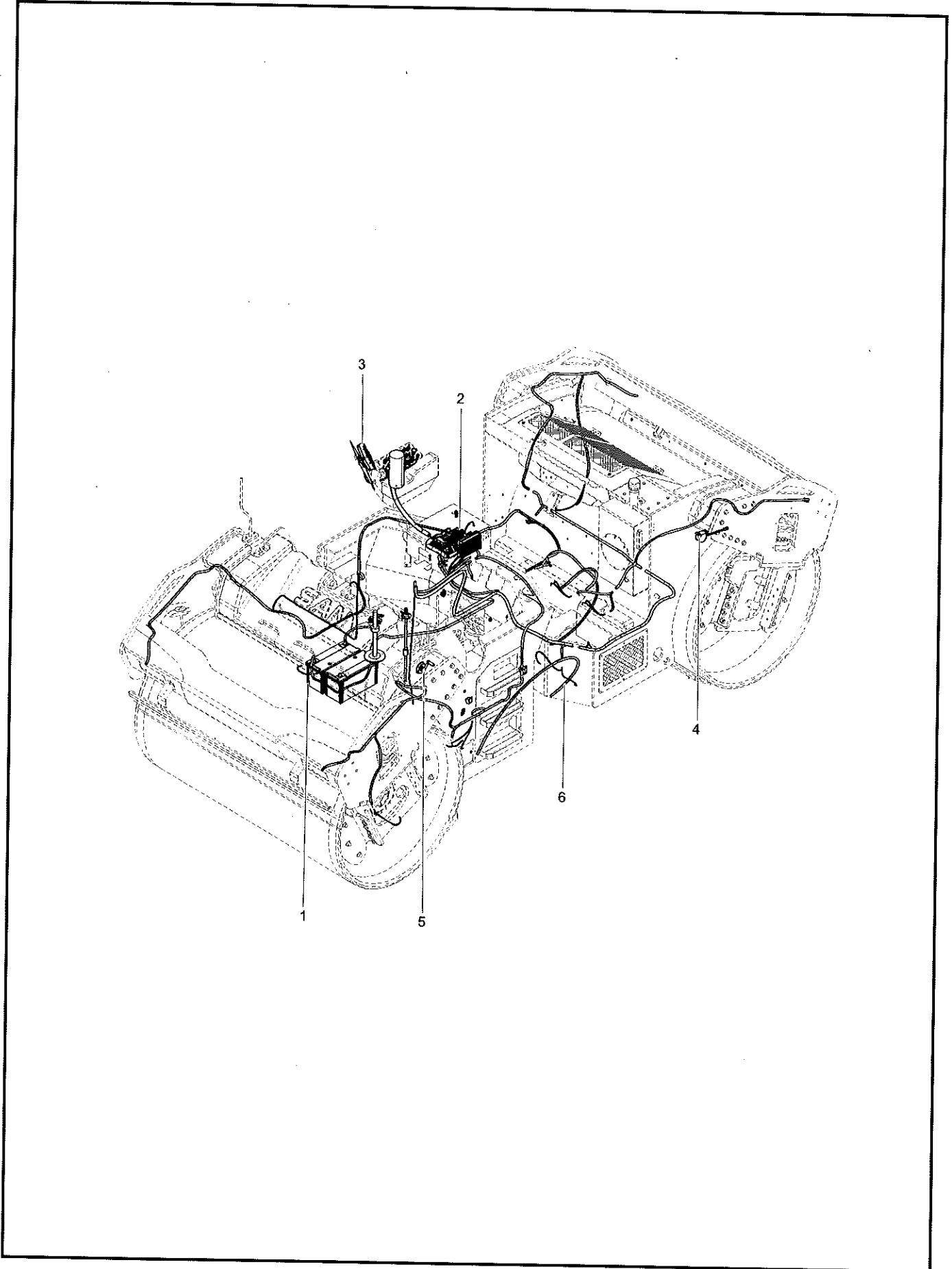

INDEX	PART NO.	DESCRIPTION	QTY	SEE PAGE
1	13455256	Power assembly	1	13-4
2	14512008	Electrical Control Box Assembly	1	13-6
3	14514219	Electric system assembly of Control box	1	13-8
4	14173552	Electrical system , rear carriage	1	13-10
5	14388807	Electrical system , front carriage	1	13-14
6	YLJ005348321	Electrical harness assembly basic diagram	1	13-22

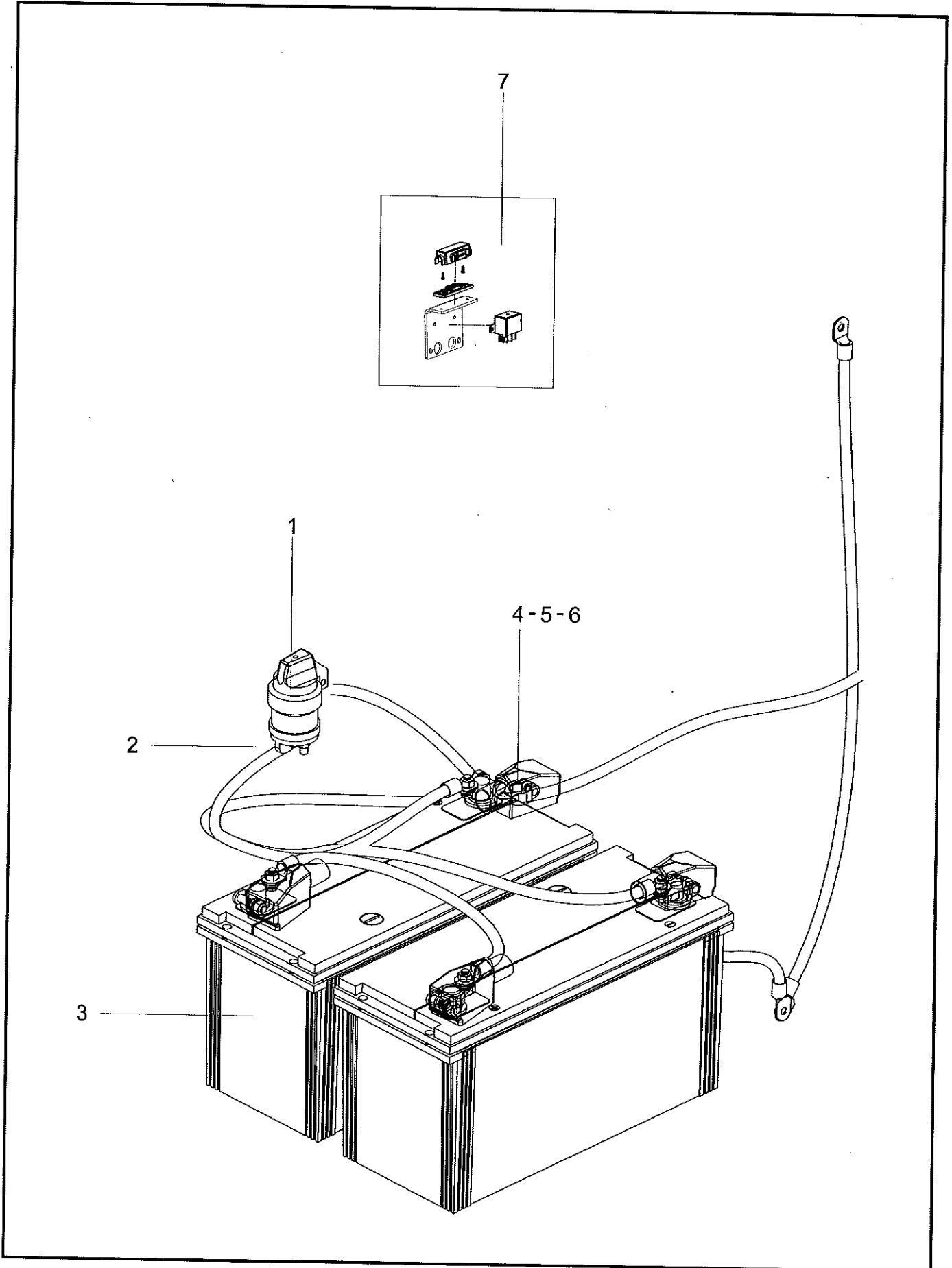

INDEX	PART NO.	DESCRIPTION	QTY	SEE PAGE
1	142507000007A	Power Supply Master Switch	1	
2	A210319000001	Nut	3	
3	60190637	Battery	2	
4	A210319000003	Nut	1	
5	60243535	Nut	1	
6	A210319000009	Nut	2	
7	13523222	Preheating System Assembly	1	

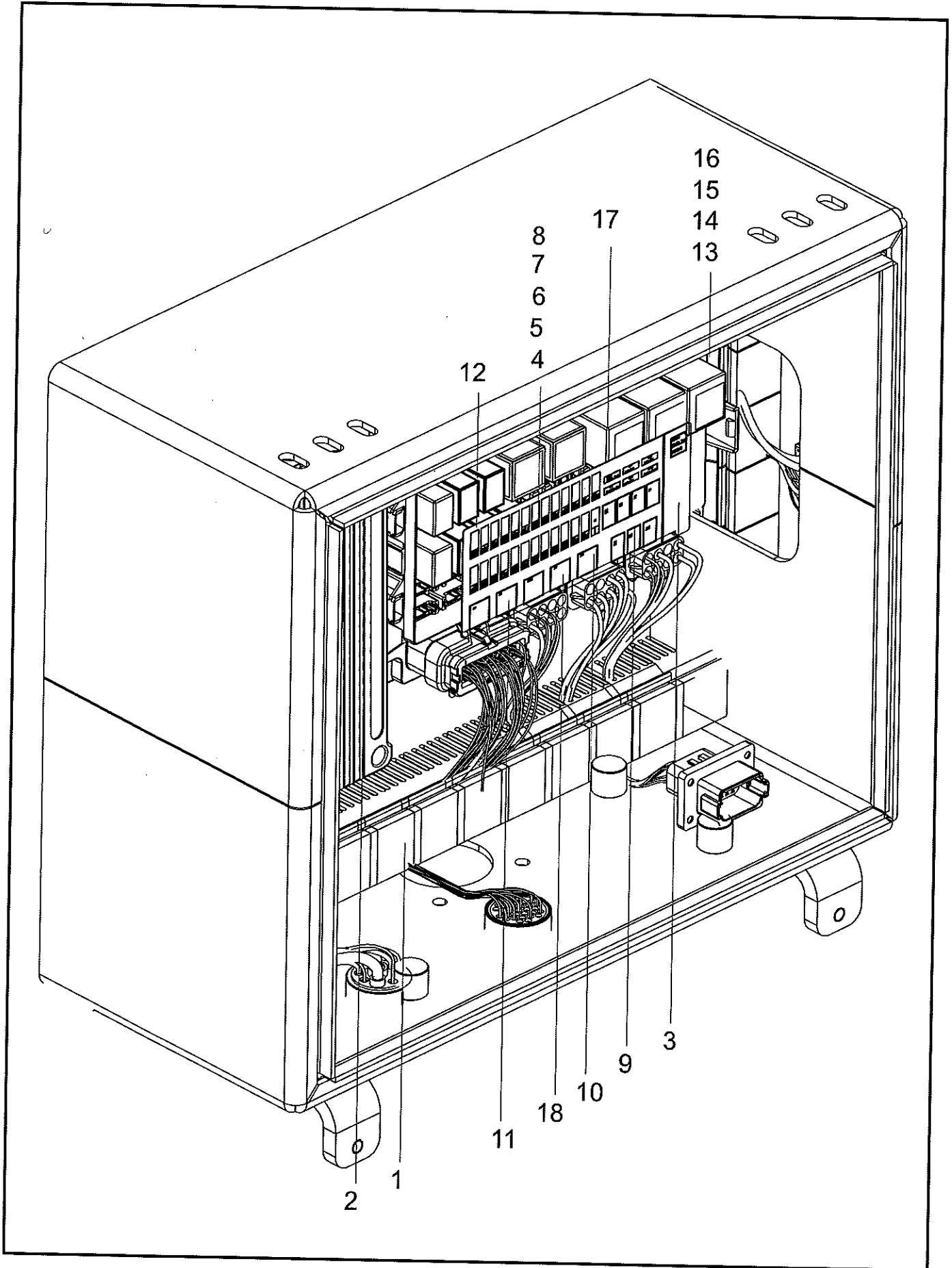

INDEX	PART NO.	DESCRIPTION	QTY	SEE PAGE
1	60208351	Gauge Line Groove	1	
2	A810201206116	Controller Assembly	1	
3	60146855	Central Appliance Case	1	
4	B241300000020	Fuse	6	
5	B241300000021	Fuse	7	
6	B241300000024	Fuse	1	
7	B241300000022	Fuse	3	
8	B241300000026	Fuse	2	
9	60151326	Intermediate Relay	5	
10	B240700000006	Intermediate Relay	2	
11	B2407000000262	Relay	2	
12	14511713	Face film	1	
13	A210111000240	Bolt	20	
14	A210111000084	Bolt	4	
15	A210111000078	Bolt	7	
16	60200720	Fastening Clamp	1	
17	60202971	Flasher Relay	1	

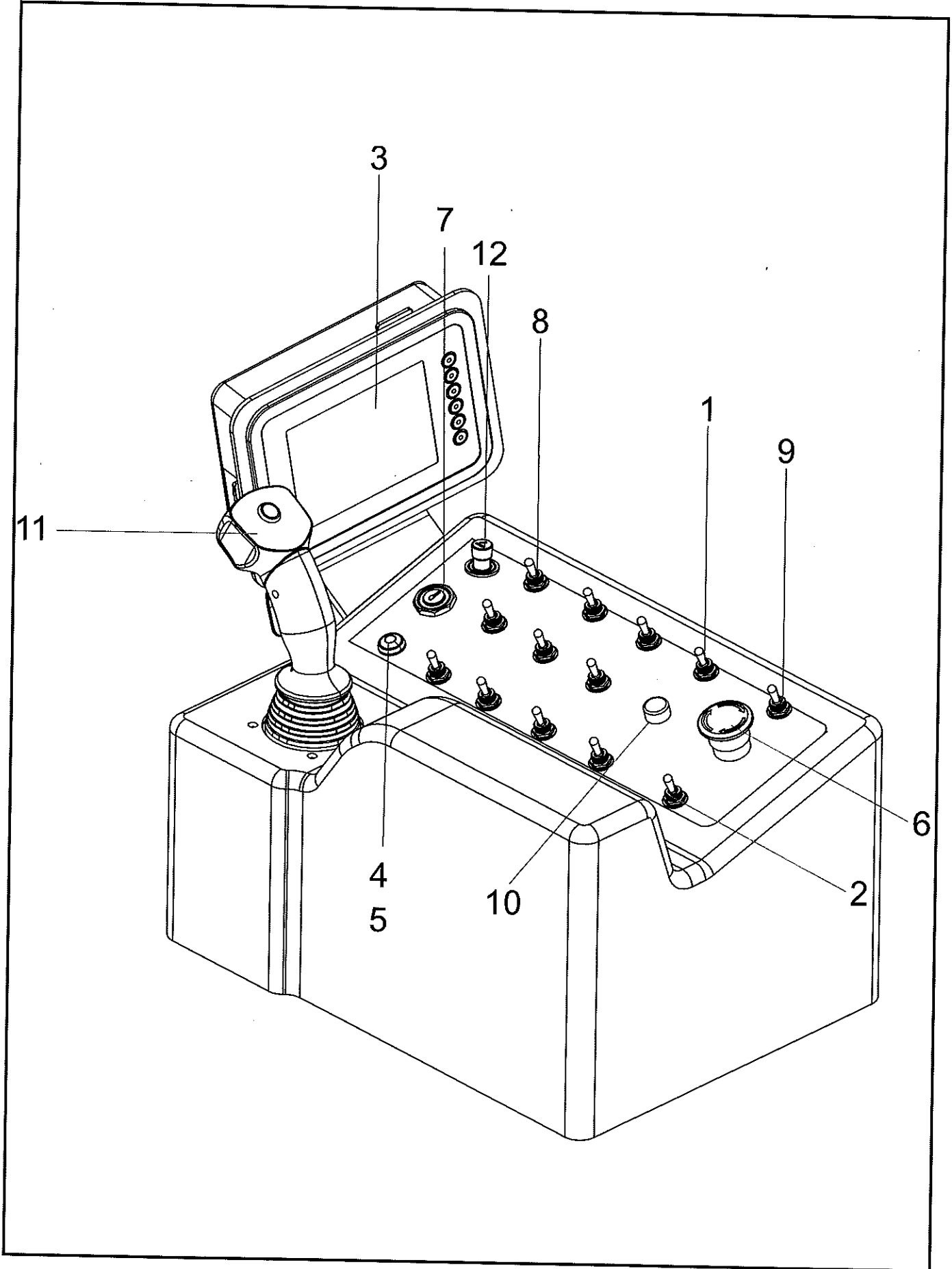



INDEX	PART NO.	DESCRIPTION	QTY	SEE PAGE
1	B241200000529	Toggle Switch	3	
2	B241200000532	Toggle Switch	3	
3	SZN007370178	SANY intelligent date DISPLAY	1	
4	60000164	Button Switch	1	
5	60026374	Contact Block, Normally-opened	1	
6	B240200000059	Emergency Stop Button	1	
7	B241200001124	Ignition Switch	1	
8	B241200000530	Toggle Switch	6	
9	B241200000531	Toggle Switch	2	
10	60134345	Indicator Lamp	1	
11	142601000026A	Electric Handle	1	
12	60105071	24V Cigarette Lighter	1	

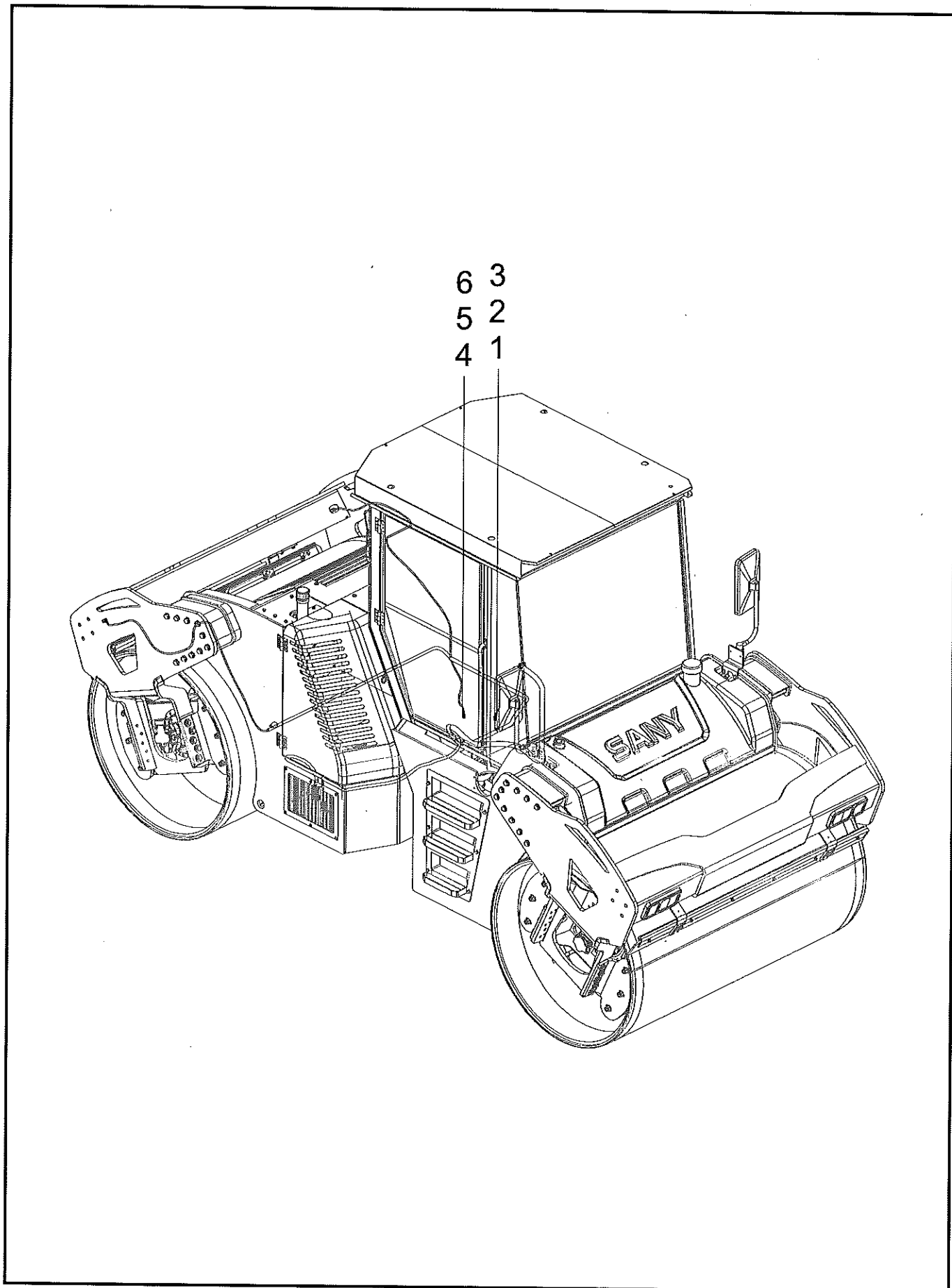

INDEX	PART NO.	DESCRIPTION	QTY	SEE PAGE
1	B241200000582	2-core Rectangular Socket	1	
2	A249900001139	Secondary Lock 2-wire (Pin)	1	
3	B249900000288	Pin	5	
4	B241200000604	Rectangular Socket	1	
5	A222200000164	Secondary Lock 4-wire Pin	1	
6	B229900002528	Blocked Up	1	
7	146399000011A	Backup Alarm	1	

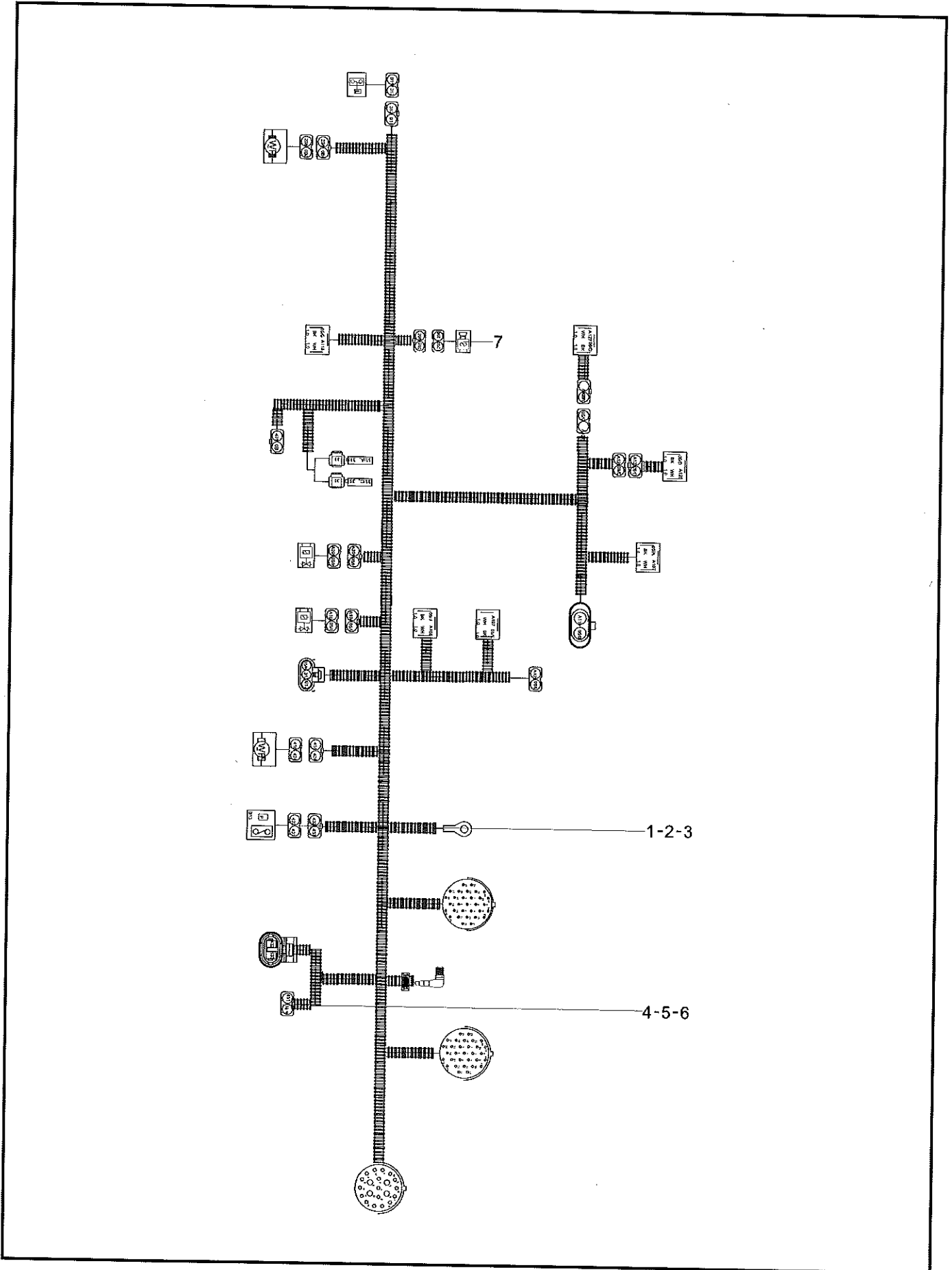

INDEX	PART NO.	DESCRIPTION	QTY	SEE PAGE
1	B241200000582	2-core Rectangular Socket	1	
2	A249900001139	Secondary Lock 2-wire (Pin)	1	
3	B249900000288	Pin	5	
4	B241200000604	Rectangular Socket	1	
5	A222200000164	Secondary Lock 4-wire Pin	1	
6	B229900002528	Blocked Up	1	
7	146399000011A	Backup Alarm	1	

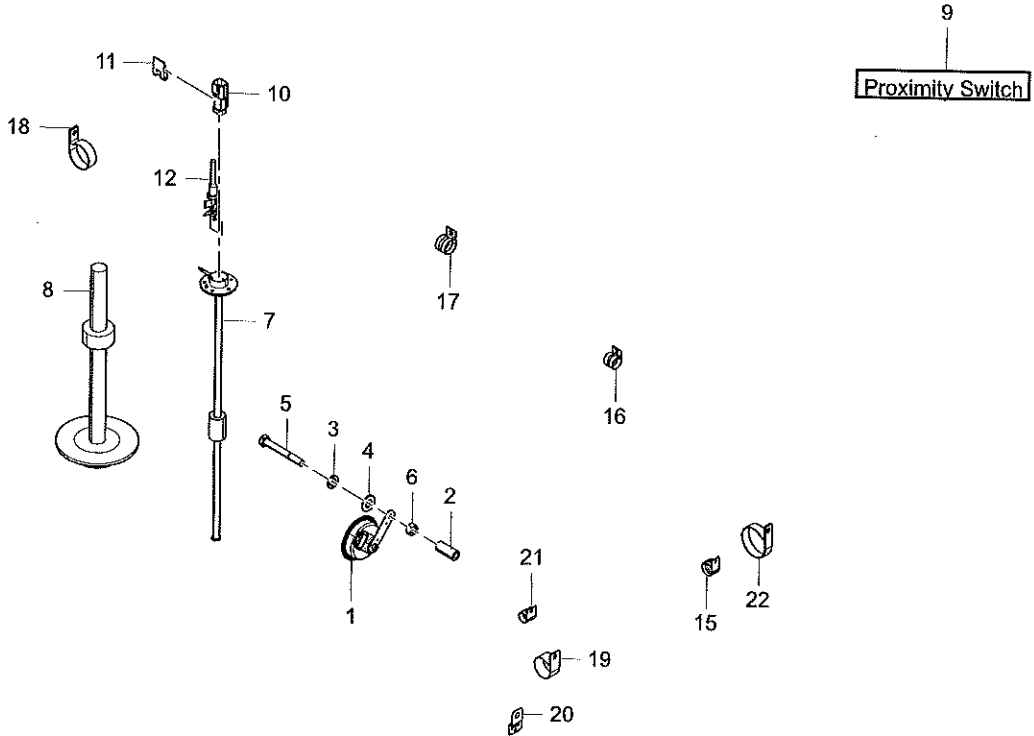
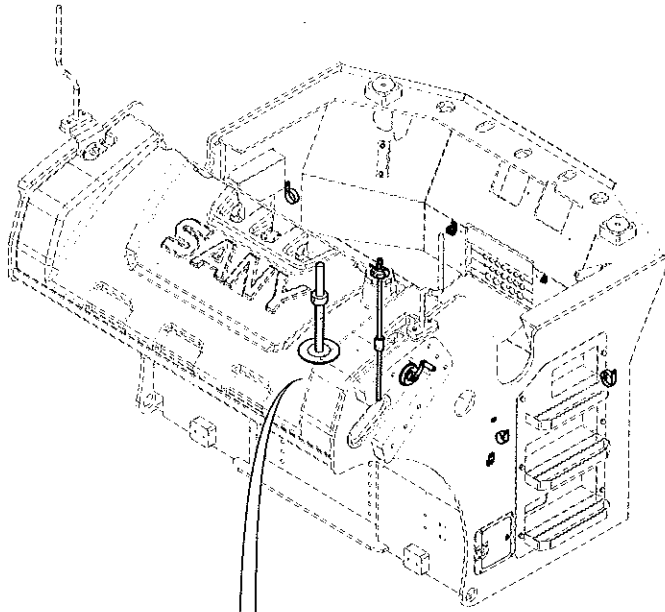

INDEX	PART NO.	DESCRIPTION	QTY	SEE PAGE
1	60246671	Speaker	1	
2	12737754	Spacer Sleeve	1	
3	A210401000017	Washer	1	
4	A210405000007	Washer	1	
5	A210110000306	Bolt	1	
6	A210307000012	Nut	1	
7	60206740	Fuel Sensor	1	
8	60282750	Level Sensor	1	
9	60203058	Proximity Switch	1	
10	B241200000582	2-core Rectangular Socket	6	
11	A249900001139	Secondary Lock 2-wire (Pin)	6	
12	B249900000288	Pin	12	
15	60200720	Fastening Clamp	15	
16	60200721	Clamp	20	
17	60200723	Fastening Clamp	15	
18	A229900003852	Clip	10	
19	60200725	Fastening Clamp	10	
20	60041902	90 Degree Metal Mounting Bracket	2	
21	60200719	Fastening Clamp	10	
22	A229900003853	Clamp	10	

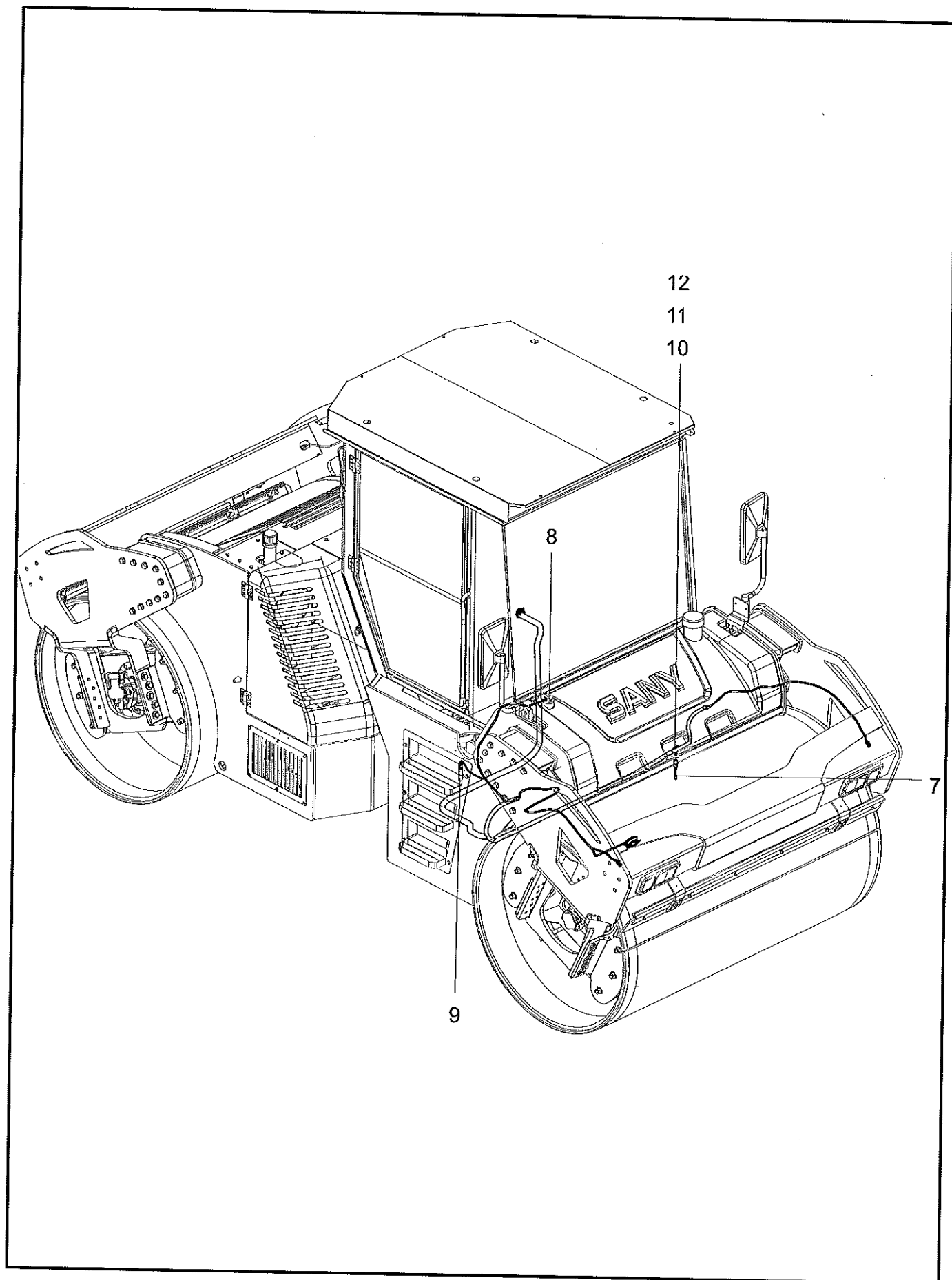



INDEX	PART NO.	DESCRIPTION	QTY	SEE PAGE
7	60206740	Fuel Sensor	1	
8	60282750	Level Sensor	1	
9	60203058	Proximity Switch	1	
10	B241200000582	2-core Rectangular Socket	6	
11	A249900001139	Secondary Lock 2-wire (Pin)	6	
12	B249900000288	Pin	12	

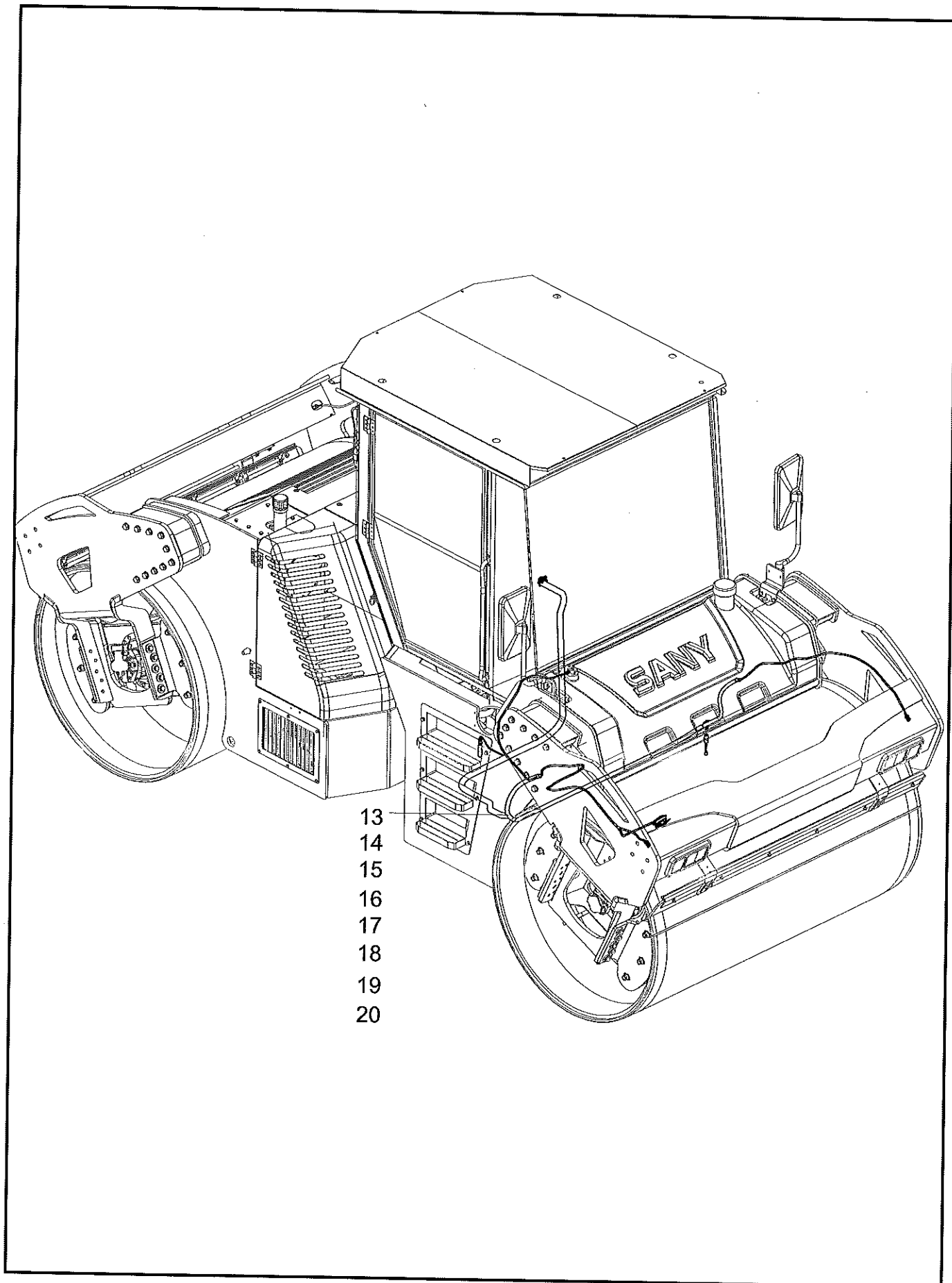

INDEX	PART NO.	DESCRIPTION	QTY	SEE PAGE
13	141601010057A	Headlamp	2	
14	141601010056A	Headlamp	2	
15	60200720	Fastening Clamp	15	
16	60200721	Clamp	20	
17	60200723	Fastening Clamp	15	
18	A229900003852	Clip	10	
19	60200725	Fastening Clamp	10	
20	60041902	90 Degree Metal Mounting Bracket	2	

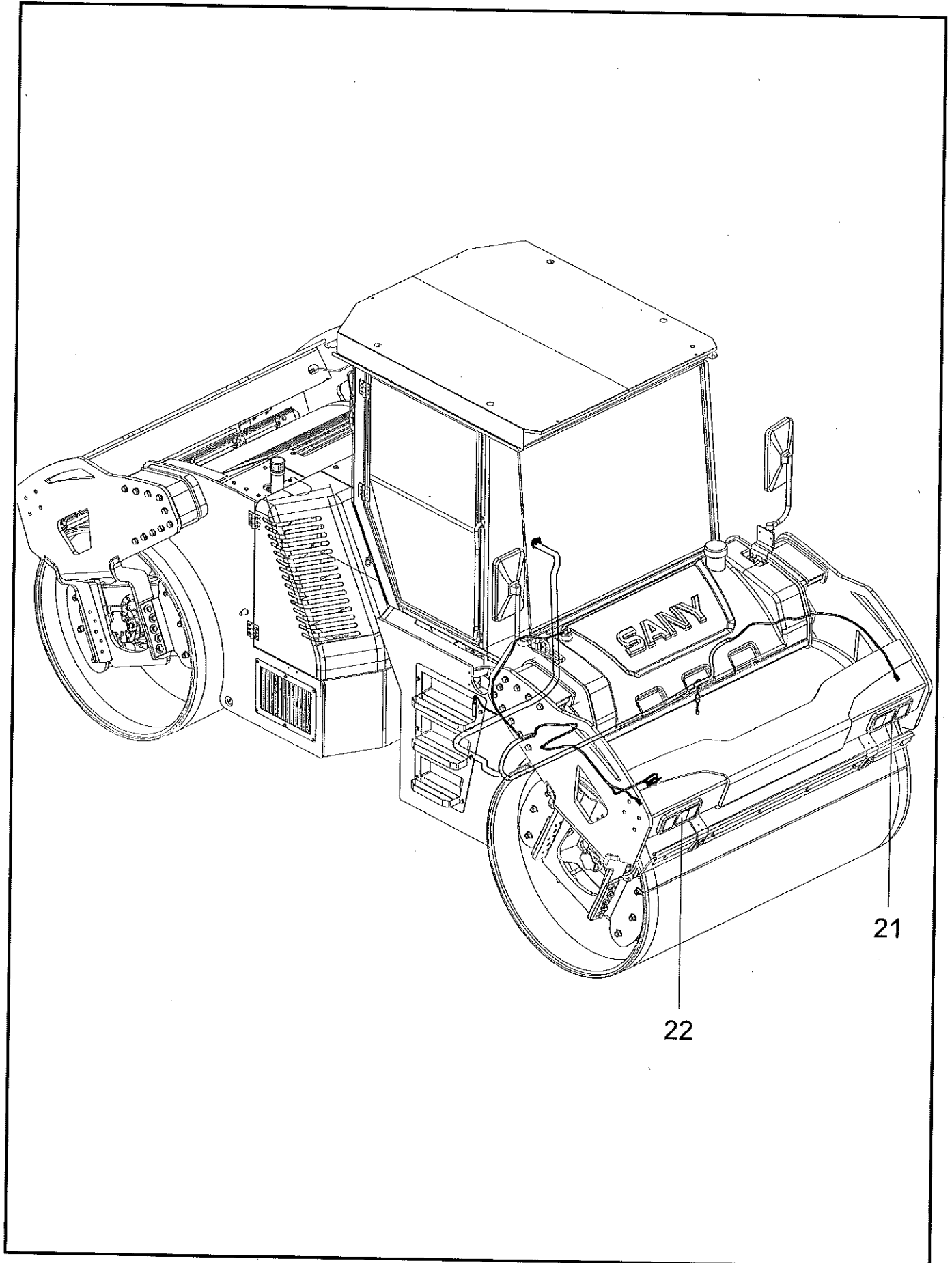

INDEX	PART NO.	DESCRIPTION	QTY	SEE PAGE
21	60200719	Fastening Clamp	10	
22	A229900003853	Clamp	10	

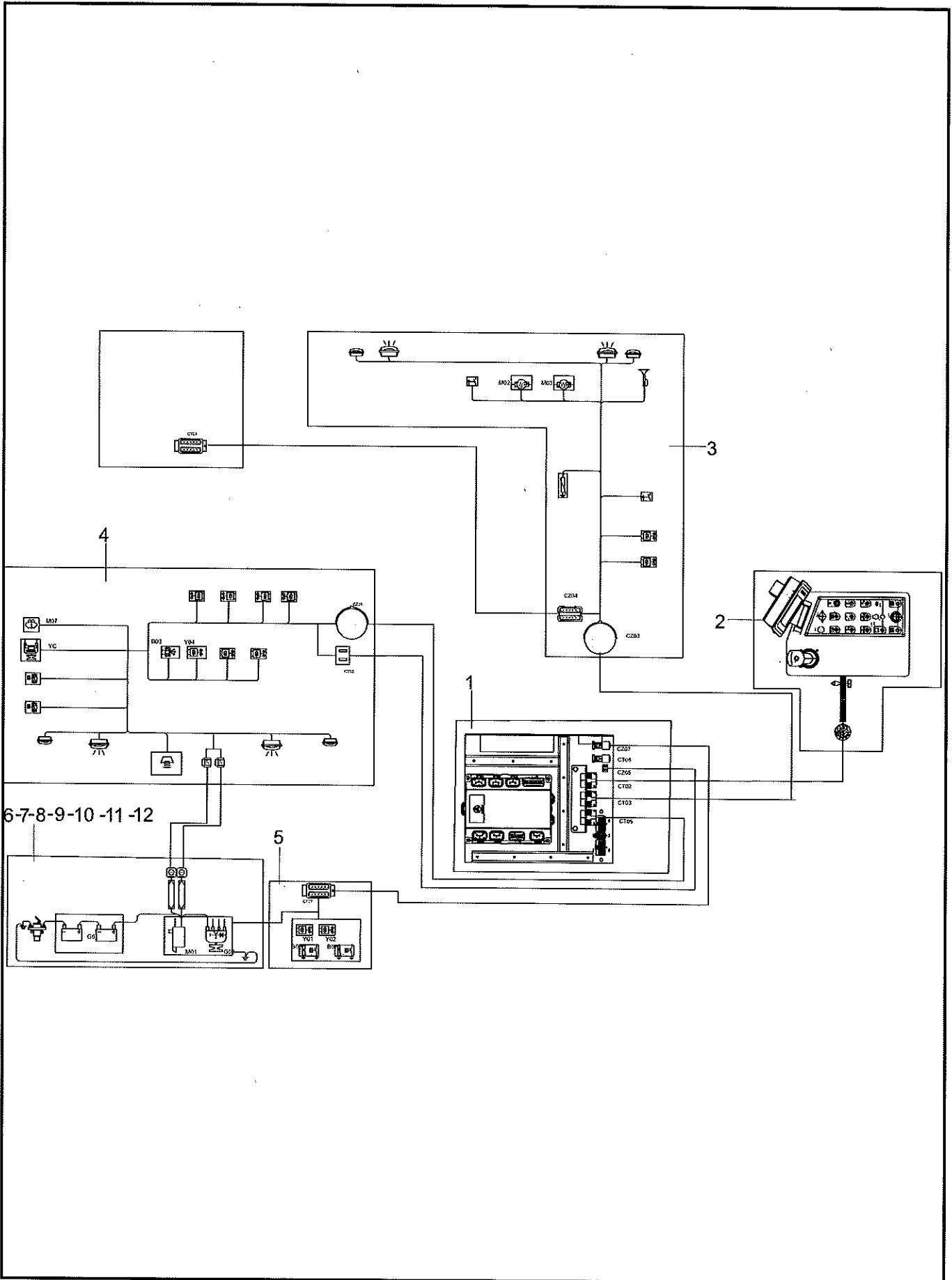

INDEX	PART NO.	DESCRIPTION	QTY	SEE PAGE
1	YLJ005348333	Electrical harness in Electric Control Cabinet wiring diagram	1	
2	14511690	Electrical harness of Control box	1	
3	YLJ005348359	Front Frame Electrical Harness wiring diagram	1	
4	YLJ005348340	Rear Frame Electrical Harness basic diagram	1	
5	YLJ005348415	Electrical harness of Engine wiring diagram	1	
6	13636316	Engine Ground Cable	1	
7	13636366	Battery switch connection	1	
8	13690724	Front Frame to Rear Frame Connecting Wire	1	
9	13127937	Wire connecting to battery	1	
10	13690725	Battery Motor connection Wire	1	
11	13690722	Earthing wire of power supply master switch	1	
12	13549882	Preheat Harness	1	

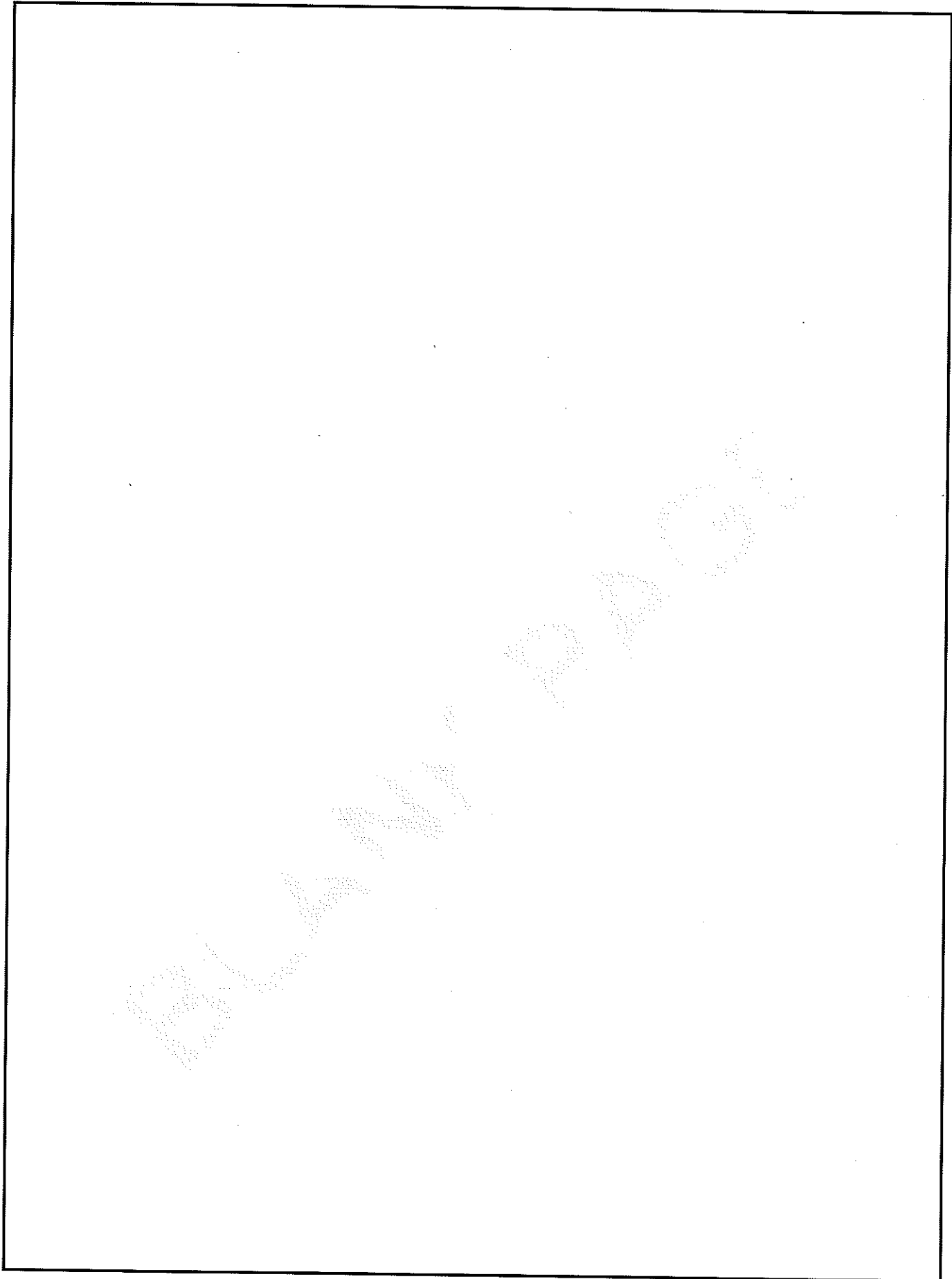



# Group 14

## Driver's Cab Assy

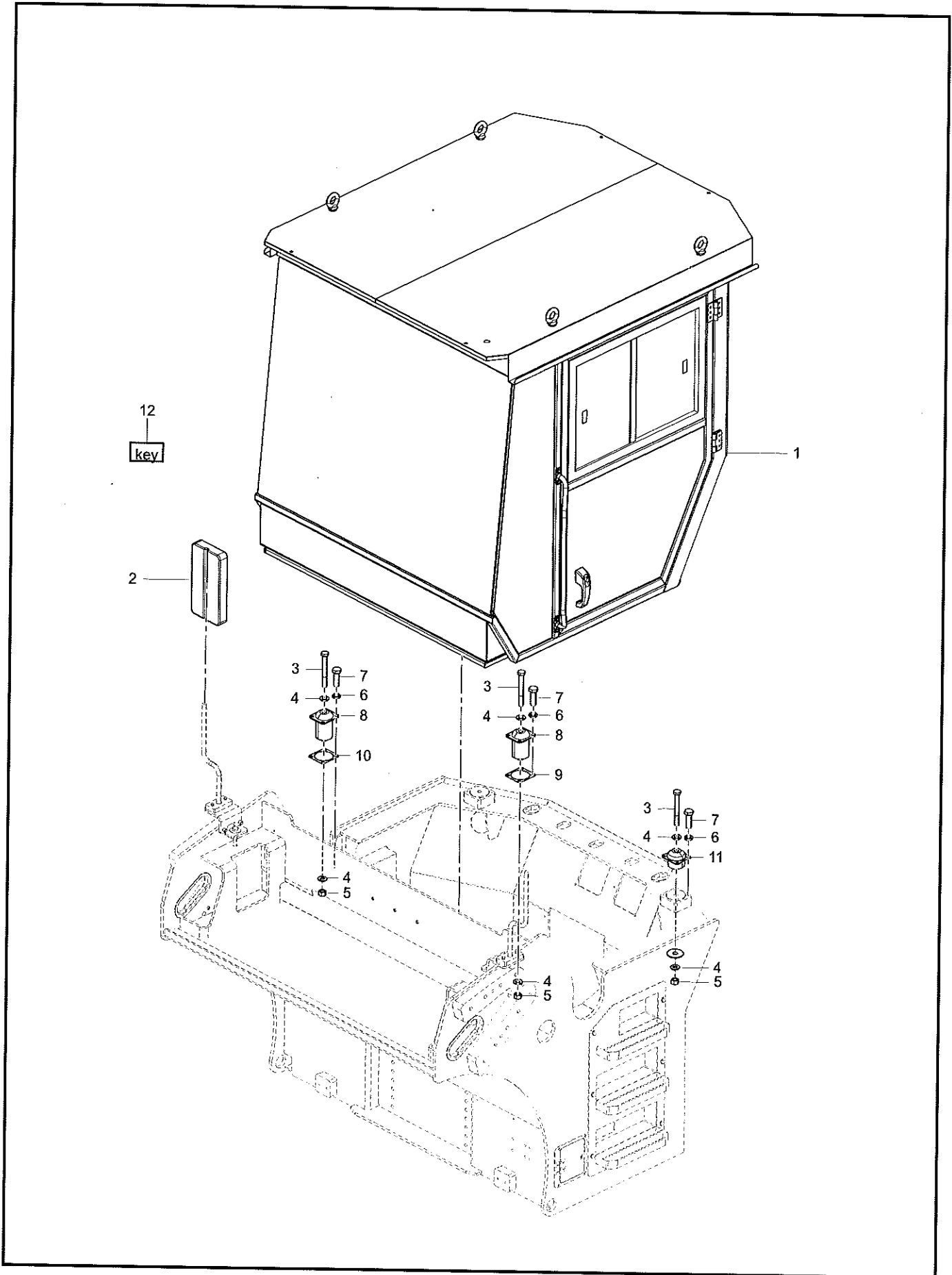

INDEX	PART NO.	DESCRIPTION	QTY	SEE PAGE
1	130901000268B	Cab(JRTR07A)	1	14-4
2	130907000166A	Rearview mirror assy	2	
3	A210110000347	Bolt	4	
4	A210491000132	Washer	8	
5	A210307000005	Nut	4	
6	A210401000002	Washer	16	
7	A210111000203	Bolt	16	
8	60017650	Damperr	2	
9	13177140	Adjusting Spacer	1	
10	13177149	Adjusting Shim	1	
11	131602000090A	Shock Absorber	2	
12	60062854	Key Ring	1	

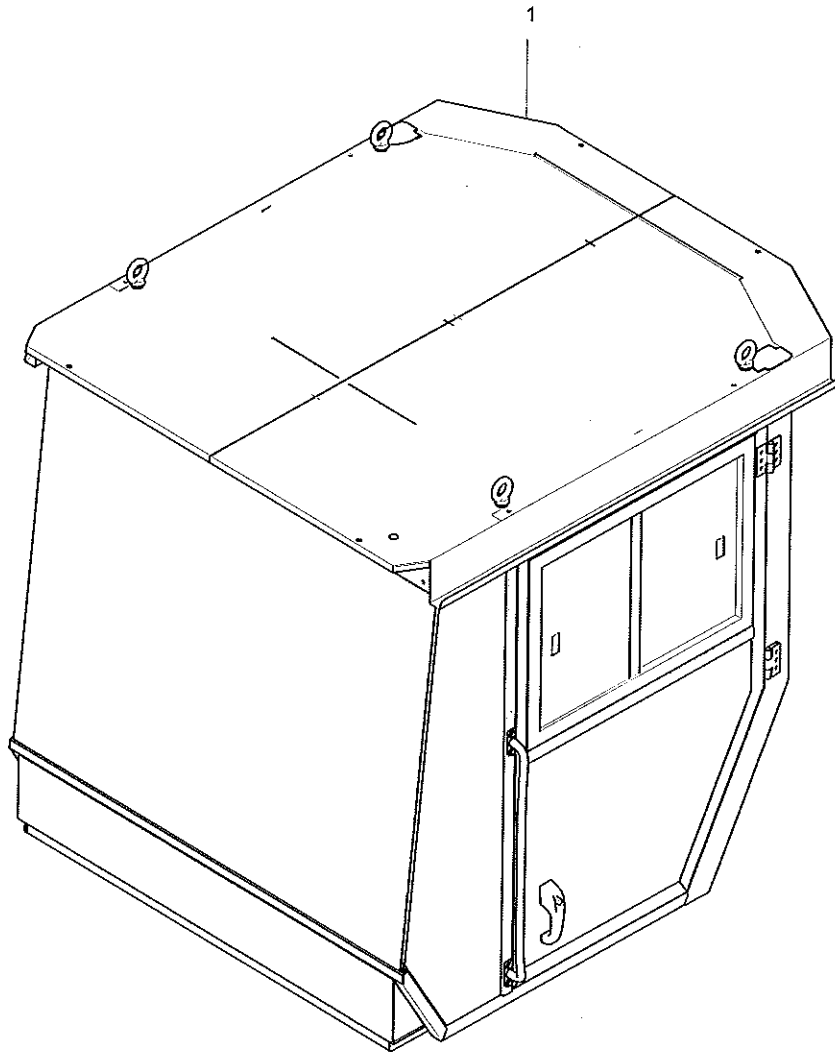

INDEX	PART NO.	DESCRIPTION	QTY	SEE PAGE
1	130901000269B	JRTR07 double steel roller cab console body	1	14-6

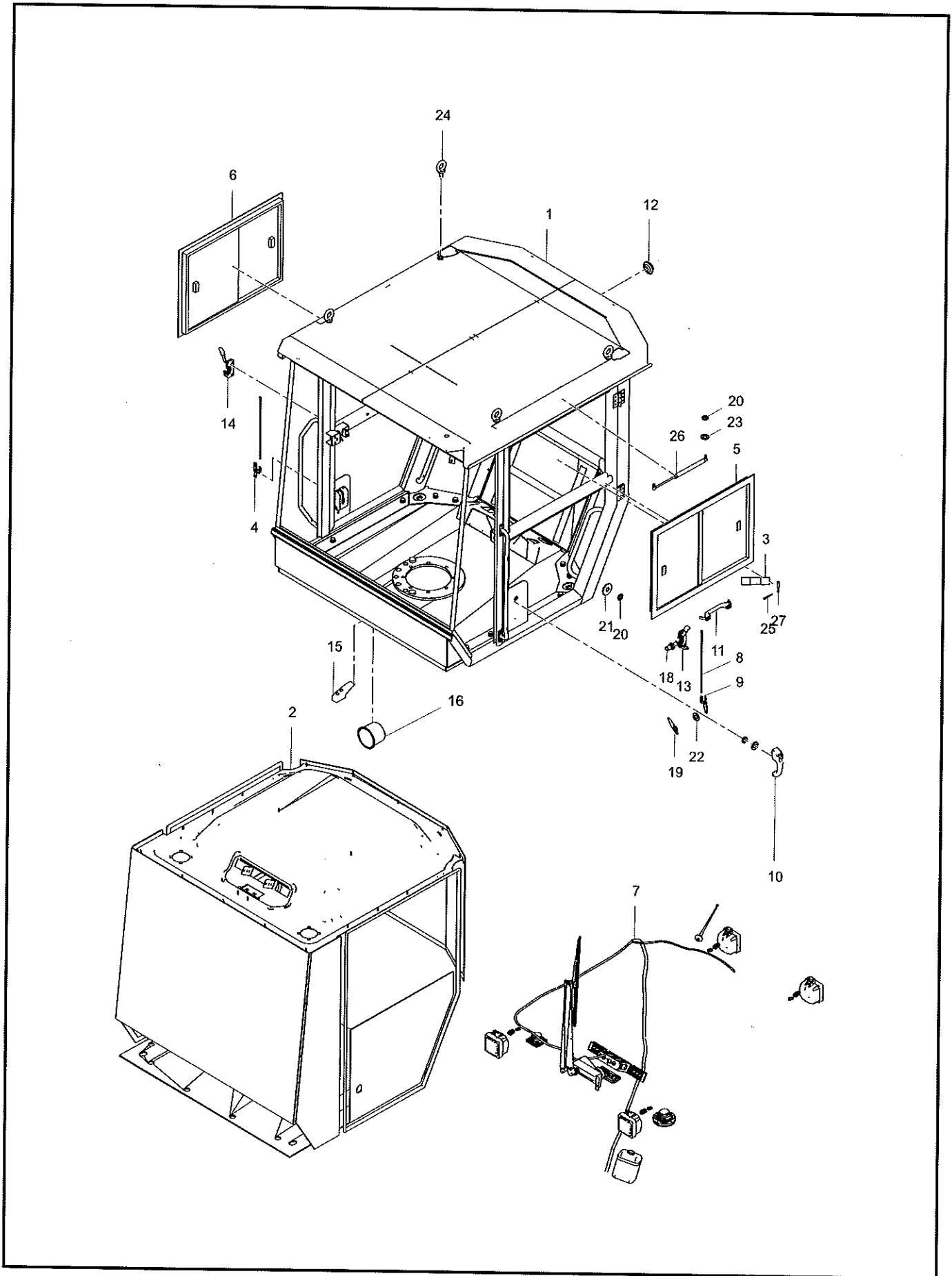

INDEX	PART NO.	DESCRIPTION	QTY	SEE PAGE
1	JSS005361405	Cab body	1	14-8
2	JSS005364030	JRTR07A inner&outer-decoration assembly	1	14-10
3	11262101	Positioning Belt, Door	2	
4	13437990	Change-over Mechanism	1	
5	13701323	Left sliding window	1	
6	13701324	Left sliding window	1	
7	13740132	Electric assembly	1	
8	13744688	Pull rod	2	
9	13755945	Change-over Mechanism	1	
10	60024135	Handle	2	
11	60031309	Handle, Auxiliary	2	
12	60042056	Plug	2	
13	60263714	Door Lock	1	
14	60312227	Right door lock	1	
15	A229900005559	Coat Hook	1	
16	JSS006065140	Big cup holder	1	
17	YLJ004964826	Phone cup	1	
18	A820301017645	Lock Pole	2	
19	A210401000016	Washer	32	
20	A210401000017	Washer	27	
21	A210404000005	Washer	23	
22	A210405000006	Washer	32	
23	A210405000007	Washer	4	
24	A210491000001	Screw	4	
25	A210491000009	Pin	4	
26	A229900009879	Gas Spring	2	
27	A31907100070B	Axis Pin	4	

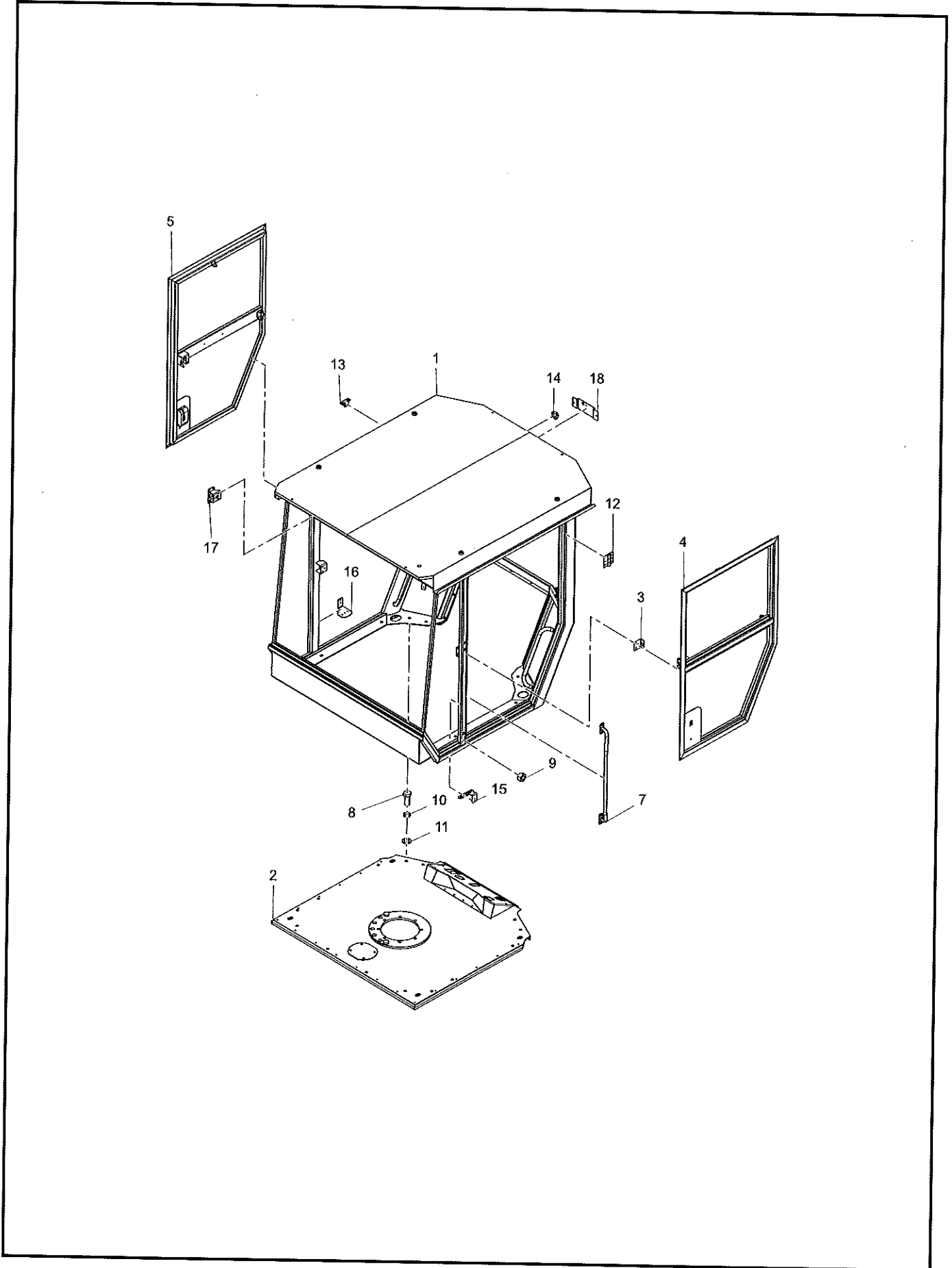



INDEX	PART NO.	DESCRIPTION	QTY	SEE PAGE
1	JSS005361407	Driver's cab welding assy	1	
2	JSS005361404	Floor welding assembly	1	
3	10347509	Support Plate II	2	
4	13707111	Left door welding assy.	1	
5	13707117	Right door welding assembly	1	
6	13707120	Rear panel assembly	1	
7	13744486	Outer armrest	2	
8	A210111000053	Bolt	14	
9	A210307000012	Nut	8	
10	A210401000004	Washer	14	
11	A210405000003	Washer	14	
12	A210891000007	Hinge	4	
13	A820101362643	Installation Seat	2	
14	60040336	Nut	2	
15	JSS006345517	Bracket	1	
16	JSS006345753	support	1	
17	JSS006382136	Fan stay Welding Assy.	1	
18	JSS006467729	stiffening plate	1	

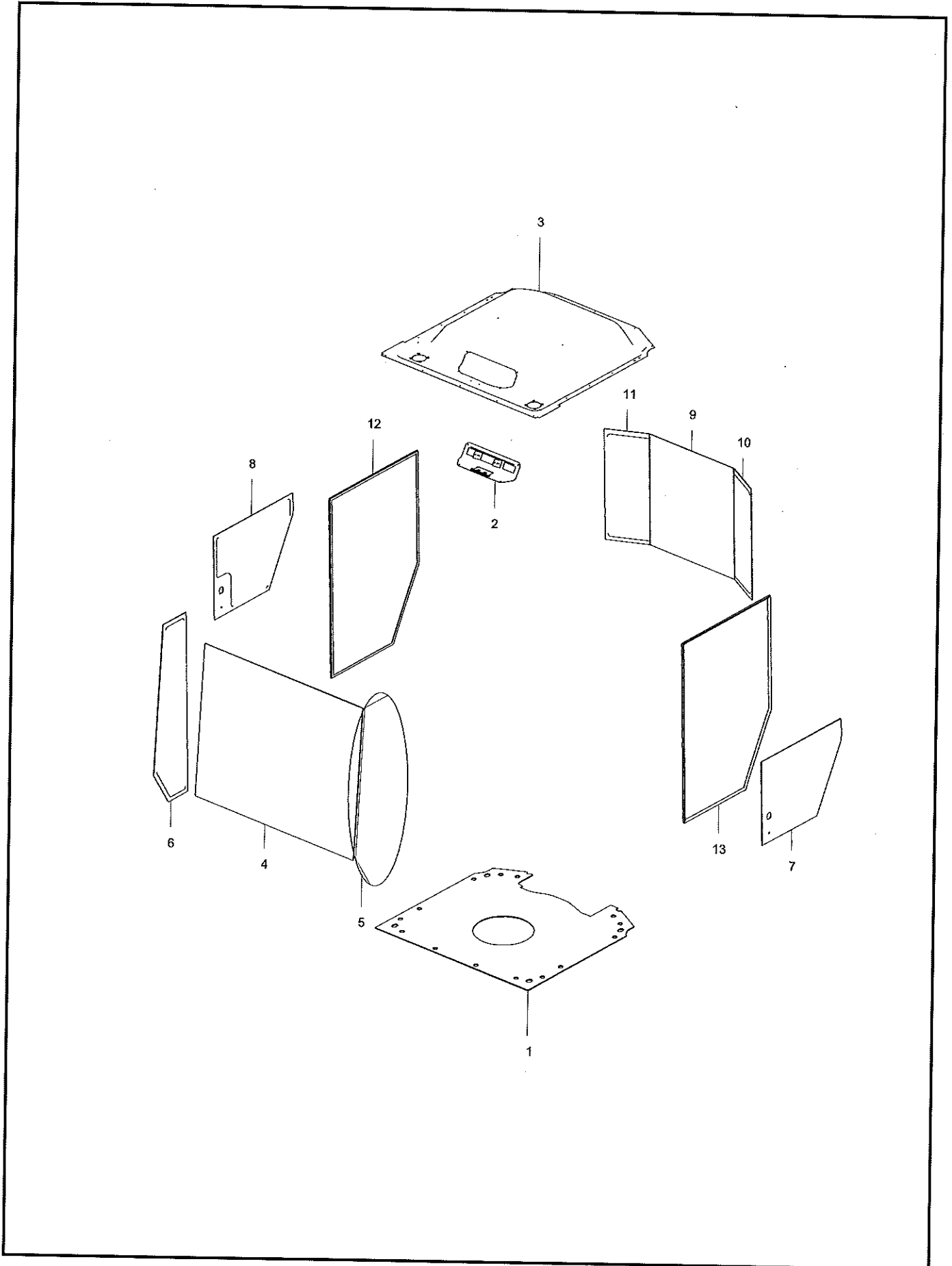

INDEX	PART NO.	DESCRIPTION	QTY	SEE PAGE
1	JSS005350459	Floor leather JRTR07A	1	
2	12332585	Overhaul, cap	1	
3	13696112	Roof guard plate	1	
4	13702460	Front window glass	1	
5	13702461	Left-front window glass	1	
6	13702462	Right-front window glass	1	
7	13702463	Left-door window glass	1	
8	13702464	Rightt-door window glass	1	
9	13702465	Rear window glass	1	
10	13702466	Left-rear window glass	1	
11	13702467	Right-rear window glass	1	
12	13705022	Right, door, sealing, strip	1	
13	13705345	Left, door, sealing, strip	1	

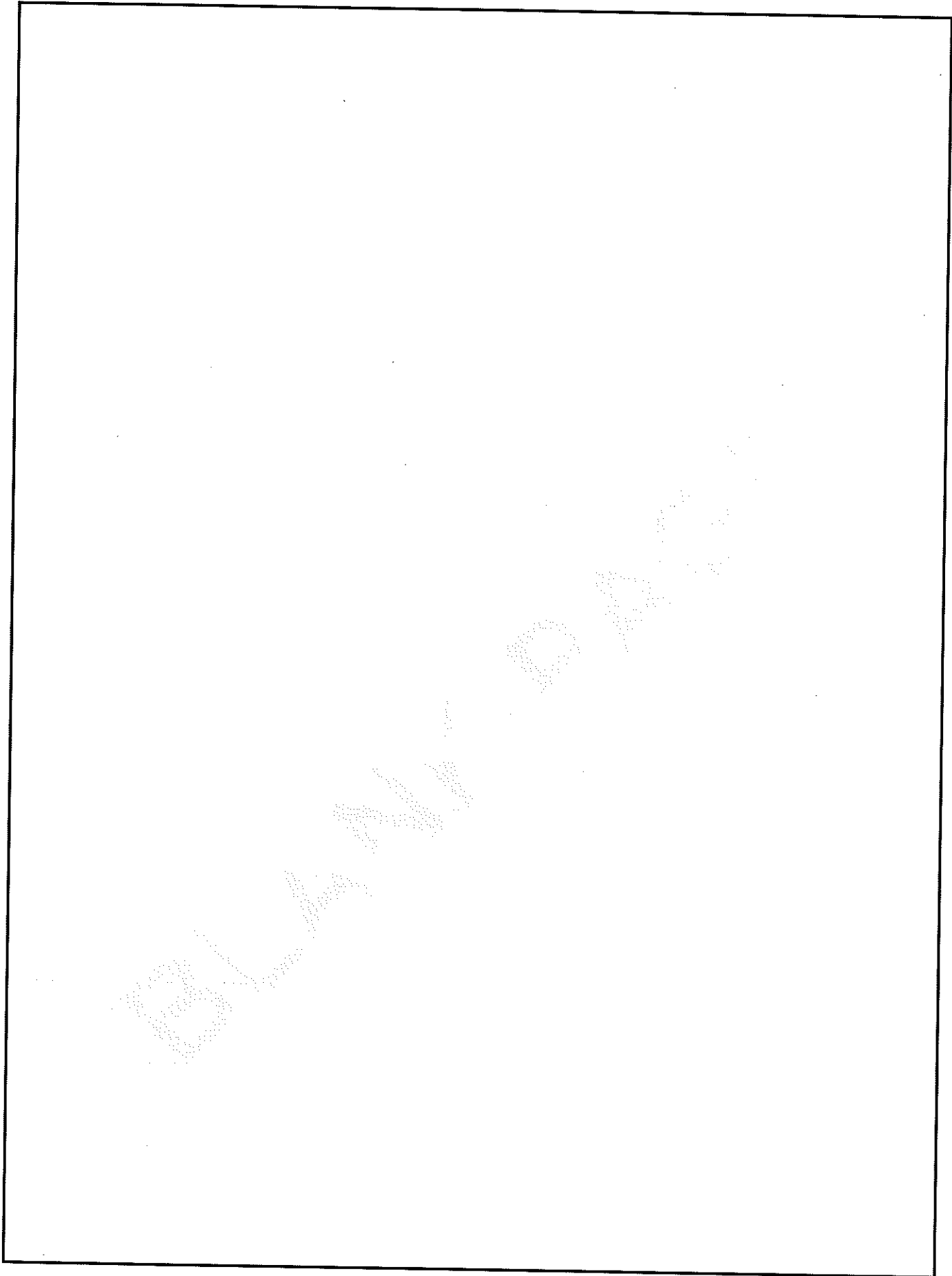

# Index

10211702 Coupling bar.....	4-9	130907000166A Rearview mirror assy.....	14-3
10212192 Support welding.....	4-11	13112771 Hose.....	8-35
10245100 Cover Plate, Flange, Oil Tank.....	10-7	13127937 Wire connecting to battery.....	13-23
10250742 Retainer Ring.....	6-7	131602000090A Shock Absorber.....	14-3
10347509 Support Plate II.....	14-9	13175440 Electrical control penal.....	4-13
10891719 Threaded Cover.....	7-9	13175443 Fixing plate.....	4-13
10891721 Threaded Cover.....	2-13	13175451 Electrical control penal component.....	4-11
10993801 Connector.....	5-5	13177140 Adjusting Spacer.....	14-3
10993805 Connector.....	5-5	13177149 Adjusting Shim.....	14-3
10994336 Cover Board, Tube Clamp.....	10-3	13181668 Retainer Ring.....	6-3, 6-5
11026326 Compressor bracket.....	5-5	13201192 Vibratory shaft.....	2-11
11101836 Damping Pad Of Radiator.....	7-11	13201312 Vibratory shaft.....	2-9
11104119 Damping bearer.....	10-3	13208018 Oil Cup Base.....	2-7
11109312 Lock pin.....	6-11	13297001 Retaining ring II.....	6-5
11109315 Handle.....	6-11	13297012 Retainer Ring.....	6-5
11122499 Stopper ring.....	6-7	13300057 Sensor Connector.....	7-17
11123065 Snap ring.....	6-7	13308908 Pipe Connector of LINON Motor.....	8-15
11262101 Positioning Belt, Door.....	14-7	13309251 Intermediate bearing seat.....	2-5
11405879 Retaining disc.....	2-3	13309621 Connection sleeve.....	2-7
11534382 Rubber pad.....	5-5	13309783 End plate.....	2-7
11558668 Hoop.....	7-11, 7-15	13311381 Scraper welding.....	2-5
11563406 Connecting Rubber Hose.....	7-11	13352058 Mounting Rack Welding.....	4-5
120701080001A Type A Triangular Belt.....	5-5	13352079 Display Mounting Rack.....	4-3
120801010021A Spring.....	11-7	13360514 Valve block body.....	8-21
12278981 Cover.....	2-7	13394536 Foot pedal.....	4-9
12281495 Cover.....	2-13	13403379 Spacer.....	2-3
12332585 Overhaul, cap.....	14-11	13437990 Change-over Mechanism.....	14-7
12355725 Screw Plug.....	6-7	13445919 Battery cover assembly.....	3-15
12359619 Sealing Ring.....	6-3, 6-5	13445921 Rubber liner plates.....	3-15
12359672 Retainer Ring.....	6-3, 6-5	13445924 Battery component.....	3-3
12360169 Lock pin.....	6-5	13448212 Valve block.....	8-11
12364139 Guide sleeve.....	6-7	13448213 Crablake valve mounting.....	8-3
12364143 Piston.....	6-7	13449188 Pressure plate.....	3-3
12364145 Rear clipping key.....	6-7	13449189 Rubber Cushion.....	3-3
12364146 Clipping key cap.....	6-7	13455256 Power assembly.....	13-3
12364147 Steering Cylinder.....	6-5	13520944 Connecting Disk.....	7-9
12364148 Cylinder assem.....	6-7	13523222 Preheating System Assembly.....	13-5
12364150 Piston rod assem.....	6-7	13523768 Front bearer board.....	7-7
12732056 Bearing seat welding.....	2-13	13549882 Preheat Harness.....	13-23
12737754 Spacer Sleeve.....	13-15	13589449 rear outrigger.....	7-5
12744699 Bearing seat component.....	2-5	13599611 GSJ Seal Ring.....	6-7
12844446 Movable block chamber welding ..	2-9, 2-11	13610941 Rock Arm.....	4-11
12844477 Fixed eccentric block.....	2-9, 2-11	13636316 Engine Ground Cable.....	13-23
12844503 Modulator, amplitude.....	2-3	13636366 Battery switch connection.....	13-23
12844646 Modulator, amplitude.....	2-5	13673659 muffler.....	7-15
12844740 Support shaft.....	3-17	13684348 Rubber retainer.....	3-5
12884288 Tube Clamp.....	10-3	13684350 Supporting plate.....	3-11
12955989 Pin.....	6-11	13684351 Axle supporting.....	3-11
12955991 Lock pin.....	6-5	13684352 Axle supporting.....	3-11
12984281 Cover plate.....	2-5	13685018 Hose clip unit.....	3-5
13021799 End cover of bearing seat.....	2-13	13686274 Fan valve mounting.....	8-5
13089922 Bushing.....	3-11	13686363 Priority valve assembly.....	8-3
130901000268B Cab(JRTR07A).....	14-3	13686364 Steering component.....	8-3
130901000269B JRTR07 double steel roller cab console body.....	14-5	13686715 Cover plate.....	3-5
		13687078 Support plate.....	11-7

13687079	Scraper.....	11-5, 11-7	13925123	Drainage adaptor.....	7-19
13687080	Pressure plate.....	11-5, 11-7	13977278	Vibratory end bearing holder.....	2-7
13687111	Supporting plate welding.....	11-5	13979898	Net plate.....	10-3
13687570	Support plate.....	11-5	13989791	Braking valve mounting.....	8-5
13687571	Support plate.....	11-5	14000982	Supporting Plate.....	2-5
13687649	Under scraper assem.....	11-3	14000983	Pedal.....	2-5
13688588	Exhaust Pipe Spacer.....	7-15	14009225	Fixing plate.....	2-3
13688857	Upper cover welding of control cabinet.....	4-9	14057294	water-in tube.....	7-13
13689696	cover plate.....	10-3	14057339	water-in tube.....	7-13
13689958	Cushion block.....	7-11	14071075	cylinder.....	5-9
13690722	Earthing wire of power supply master switch.....	13-23	14130377	Rubber retainer (3).....	3-3
13690724	Front Frame to Rear Frame Connecting Wire.....	13-23	14155306	Steering Control System.....	4-3
13690725	Battery Motor connection Wire.....	13-23	14155632	Rubber pad.....	4-9
13696112	Roof guard plate.....	14-11	14159223	Screw.....	3-15
13701323	Left sliding window.....	14-7	141601010056A	Headlamp.....	13-19
13701324	Left sliding window.....	14-7	141601010057A	Headlamp.....	13-19
13702460	Front window glass.....	14-11	14160181	Cylinder Assembly, Steering.....	6-5
13702461	Left-front window glass.....	14-11	14160284	Roller Wheel.....	2-3
13702462	Right-front window glass.....	14-11	14163131	Package of process sealing parts.....	6-9
13702463	Left-door window glass.....	14-11	14173552	Electrical system , rear carriage.....	13-3
13702464	Right-door window glass.....	14-11	14184596	Weldment of watering tube.....	7-11
13702465	Rear window glass.....	14-11	14208716	Filter supporting board.....	8-27
13702466	Left-rear window glass.....	14-11	14217318	cushion block.....	7-5
13702467	Right-rear window glass.....	14-11	14217405	left outrigger welding assembly.....	7-5
13705022	Right, door, sealing, strip.....	14-11	14217505	Right outrigger welding assembly.....	7-7
13705345	Left, door, sealing, strip.....	14-11	14242649	Steering board weldedment.....	4-9
13707111	Left door welding assy.....	14-9	142507000007A	Power Supply Master Switch.....	13-5
13707117	Right door welding assembly.....	14-9	142601000026A	Electric Handle.....	13-9
13707120	Rear panel assembly.....	14-9	14274679	prefiltration support.....	7-19
13718118	Degassing pipe.....	7-13	14309077	Rubber retainer.....	10-3
13731104	Bracket uppercover board.....	4-9	14309087	Ring.....	3-5, 10-3
13740132	Electric assembly.....	14-7	14321843	vibration dummy club welding.....	2-3
13744486	Outer armrest.....	14-9	14321864	driving dummy club welding.....	2-3
13744688	Pull rod.....	14-7	14321909	Fork leg.....	2-3
13755945	Change-over Mechanism.....	14-7	14321920	Fork leg.....	2-3
13765129	Preheating Mounting Rack.....	7-19	14323427	Outlet piping installation.....	12-3
13817935	Support plate welding.....	2-5	14352067	Console bracket assembly.....	4-3
13818666	Support plate welding.....	2-3	14353444	Harness installation plate.....	4-15
13836405	Axle supporting.....	3-17	14353567	Side box base plate.....	4-15
13836428	Bushing.....	3-17	14354634	Sealing ring.....	4-11
13867303	Shim.....	2-3	14354664	Lock plate.....	4-9
13892899	Supporting plate.....	3-17	14380664	Fixing plate.....	2-3
13892906	Bushing.....	3-17	14385045	Travel supporting in vibration end.....	2-3
13892932	Hose clip unit.....	3-3	14388807	Electrical system , front carriage.....	13-3
13915464	Oil collection block.....	8-25	14395896	Clamp.....	2-3
13916302	BLOCK OF collecting assembly.....	8-5	14395968	Clamp.....	2-3
13917155	Return Block.....	8-17	14396902	Cover plate.....	10-3
13917318	Return Block assembly.....	8-5	14396915	Cover plate.....	10-3
13918399	filter assembly.....	8-5	14414864	Installation adaptor of fan.....	7-13
13919808	Connecting Rubber Hose.....	7-11	14463742	L-shape plate.....	4-3
13919828	Inter-cooler intake pipe.....	7-13	14463848	U plate.....	4-3
13919833	Discharging tube.....	7-13	14464030	U plate.....	4-3
13920410	engine installation.....	7-3	14485553	Console bracket weldment.....	4-9
13920581	cover plate.....	10-3	14495199	Right plate.....	5-9
13921420	Exhaust hose.....	7-15	14495244	Left plate.....	5-9
13922408	ecise filtration supporting board.....	7-19	14506058	pump connection.....	7-3
13922412	Engine oil cleaner filtration supporting board.....	7-19	14510370	hydraulic fuel tank welding assy.....	10-7
			14510385	oil tank.....	10-3
			14511035	Electrical system of roller.....	1-3
			14511191	Hydraulic system assembly.....	1-3
			14511380	Traveling motor.....	8-3

14511533 Vibratory motor.....	8-5	60033445 Throttle Screw Plug.....	8-11
14511690 Electrical harness of Control box.....	13-23	60034012 Damp block.....	2-3
14511708 Steering Pump.....	8-5	60034759 Rubber Hose.....	8-33
14511713 Face film.....	13-7	60034933 Fan.....	7-13
14511747 Fan motor component.....	8-5	60035082 Felt Seal Ring.....	2-7
14512008 Electrical Control Box Assembly.....	13-3	60035539 Electromagnetic Reversing Valve.....	8-11
14512102 Triple Pump.....	8-5	60040336 Nut.....	14-9
14512830 Piping diagram of traveling system.....	8-5	60041902 90 Degree Metal Mounting Bracket ..	13-15, 13-19
14513010 Piping diagram of vibratory system.....	8-5	60042056 Plug.....	14-7
14513076 Radiator of vibratory system.....	8-5	60045017 Detachable Fitting.....	6-3, 6-5
14513087 Pipeline layout of brake and steering systems.....	8-5	60062854 Key Ring.....	14-3
14514219 Electric system assembly of Control box.....	13-3	60065473 Rubber Hose.....	8-37
14517625 Side box support plate welding.....	4-9	60082193 Screw.....	2-5
14519482 Front cover plate weldment.....	4-9	60082894 Joint Bearing.....	6-3
14523445 Rubber retainer.....	3-3, 10-3	60105071 24V Cigarette Lighter.....	13-9
14524432 Rubber retainer.....	10-3	60105336 Plunger Motor.....	8-15
14529231 Rubber retainer.....	10-3	60109047 Breather.....	2-3
14545153 Clamp.....	2-5	60127341 Hose.....	8-35
14545154 Clamp.....	2-3	60134345 Indicator Lamp.....	13-9
146399000011A Backup Alarm.....	13-11, 13-13	60134354 Throat Collar.....	7-13
150102030012A Plunger Pump.....	8-29	60146855 Central Appliance Case.....	13-7
150102030013A Plunger Pump.....	8-29	60151326 Intermediate Relay.....	13-7
150202040038B Plunger Motor.....	8-7, 8-43	60165875 Pipe Adapter.....	8-33
151005110049A Rubber hose assembly.....	8-39	60190637 Battery.....	13-5
151007060002 Rubber Hose Assembly.....	8-33	60191772 Right-angle Joint, Clamp Sleeve-type.....	6-3
151007260233A Rubber Hose Assembly.....	8-39	60191773 Right-angle Joint, Clamp Sleeve-type.....	6-3, 6-5
151007260304B Hose Assembly.....	8-37	60200719 Fastening Clamp.....	13-15, 13-21
151207000029B Pressure-measuring Connector.....	8-27, 8-33, 8-35	60200720 Fastening Clamp.....	13-7, 13-15, 13-19
151207000031B Pressure-measuring Connector.....	8-37	60200721 Clamp.....	13-15, 13-19
151302010028A Pipe Clip.....	11-7	60200723 Fastening Clamp.....	13-15, 13-19
151399000452A protective sleeve.....	8-39	60200724 Fastening Clamp.....	5-5
151402030066A Oil seal.....	2-7	60200725 Fastening Clamp.....	13-15, 13-19
160102050024A engine.....	7-5	60202197 Pipe connector.....	8-37, 8-39
21003889 Hose.....	8-35	60202971 Flasher Relay.....	13-7
21005327 Bolt.....	4-13	60203058 Proximity Switch.....	13-15, 13-17
21005351 Bolt.....	5-9	60206740 Fuel Sensor.....	13-15, 13-17
21011473 Rubber Hose.....	8-33	60207510 rubber hose.....	8-37
21017994 Screw Plug.....	7-19	60208351 Gauge Line Groove.....	13-7
21020350 Rubber Hose.....	8-33	60220963 Speed Sensor.....	8-43
21021877 Hose.....	8-33	60229226 End straight joint.....	8-27
21021914 Rubber Hose.....	7-19	60231763 Rolling Bearing.....	2-5
21023547 Screw plug.....	8-33	60235408 Hydraulic Control One-way Valve.....	8-11
21032394 Rubber Hose.....	8-35	60243535 Nut.....	13-5
23000678 Screw Plug.....	8-25	60244891 Flexible Coupling.....	2-5
23001025 Rubber Hose.....	8-33	60246671 Speaker.....	13-15
24002383 O-ring.....	2-5	60249822 Screw.....	8-11
60000164 Button Switch.....	13-9	60253934 Rubber Hose.....	5-5
60005842 Plug Screw.....	8-41	60260271 High Pressure Filter.....	8-27
60008237 Rubber Hose.....	8-35	60263714 Door Lock.....	14-7
60015644 Hinge.....	3-13	60277744 External-meshing Gear Pump.....	8-29
60016447 Pressure-measuring Fitting.....	8-41	60280112 Gear Pump.....	8-19
60017650 Damperr.....	14-3	60282750 Level Sensor.....	13-15, 13-17
60024135 Handle.....	14-7	60283185 Gear Motor.....	8-23
60026374 Contact Block, Normally-opened.....	13-9	60311658 Check Valve.....	8-17
60031250 Tool hasp.....	9-3	60312227 Right door lock.....	14-7
60031309 Handle, Auxiliary.....	14-7	60312939 Rubber Hose.....	7-19
60033283 Magnetic screw plug.....	2-7	60332213 rubber hose.....	8-33
		60340908 Radiator.....	7-13

60345452 rubber hose.....	8-37	A210204000019 Screw.....	3-3
60345453 rubber hose.....	8-37	A2102040000119 Screw.....	8-41
61005880 Reducer.....	2-5	A2102040000122 Screw.....	8-11
61010743 Instrument panel assembly.....	4-7	A2102040000130 Screw.....	4-15
61016820 Flexible Coupling.....	2-3	A2102040000131 Screw.....	2-3, 4-15
61030482 Double Drum Vibratory Roller Air-condition Assy.....	5-3	A2102040000151 Screw.....	8-21
A210110000006 Bolt.....	4-3	A2102040000161 Screw.....	3-17, 8-27
A210110000201 Bolt.....	6-3	A2102040000162 Screw.....	8-15, 8-27
A210110000218 Bolt.....	3-3	A2102040000164 Screw.....	7-11
A210110000304 Bolt.....	5-7	A2102040000179 Screw.....	8-13
A210110000306 Bolt.....	13-15	A2102040000197 Screw.....	5-7
A210110000331 Bolt.....	2-3	A2102040000206 Screw.....	7-5
A210110000347 Bolt.....	14-3	A2102040000215 Screw.....	7-9, 8-7, 8-37, 8-43
A210111000011 Bolt.....	2-13, 3-3	A2102040000221 Screw.....	2-7
A210111000018 Bolt.....	3-11, 4-7, 5-5	A2102040000337 Screw.....	7-5
A210111000023 Bolt.....	7-19, 11-5	A2102040000342 Screw.....	2-3, 8-41
A210111000024 Bolt.....	7-11, 7-15	A2102040000346 Screw.....	2-3
A210111000026 Bolt.....	2-3, 5-7, 7-15	A2102040000347 Screw.....	11-3
A210111000027 Bolt.....	11-5, 11-7	A2102040000354 Screw.....	7-9, 8-19
A210111000029 Bolt.....	7-19, 11-7	A2102040000356 Screw.....	2-5
A210111000032 Bolt.....	10-3	A2102100000003 Screw.....	3-7
A210111000037 Bolt.....	3-3, 6-11, 10-7	A2102100000030 Screw.....	4-3, 4-5
A210111000038 Bolt.....	6-5	A2102110000008 Screw.....	3-13
A210111000040 Bolt.....	7-19, 11-5	A2103070000001 Nut.....	3-3, 7-19, 11-5
A210111000053 Bolt.....	2-5, 14-9	A2103070000005 Nut.....	14-3
A210111000054 Bolt.....	2-3	A2103070000012 Nut.....	4-9, 7-11, 7-15, 7-19, 8-11, 9-3, 13-15, 14-9
A210111000062 Bolt.....	2-3	A2103070000015 Nut.....	9-3
A210111000071 Bolt.....	9-3	A2103070000016 Nut.....	3-5, 4-11, 5-5, 7-11
A210111000078 Bolt.....	4-9, 5-5, 13-7	A2103070000017 Nut.....	3-3, 3-11, 3-15, 3-17, 5-7, 7-11, 7-19, 11-5, 11-7
A210111000079 Bolt.....	10-3	A2103070000029 Nut.....	5-7
A210111000080 Bolt.....	3-13, 4-9	A2103070000040 Nut.....	5-7
A210111000081 Bolt.....	4-9	A2103090000016 Nut.....	7-17
A210111000084 Bolt.....	13-7	A2103150000005 Nut.....	2-3
A210111000088 Bolt.....	2-7, 2-13, 9-3, 10-7	A2103190000001 Nut.....	13-5
A210111000089 Bolt.....	3-5, 4-9, 6-3, 7-15	A2103190000003 Nut.....	13-5
A210111000090 Bolt.....	2-5, 4-9, 5-9, 7-15, 10-3	A2103190000009 Nut.....	13-5
A210111000091 Bolt.....	7-19	A2103320000004 Screw Plug.....	2-7
A210111000092 Bolt.....	3-9	A2103330000001 Plug, Screw.....	2-7
A210111000094 Bolt.....	7-19	A2103330000007 Screw Plug.....	2-5
A210111000119 Bolt.....	5-7, 7-5	A2104010000001 Washer.....	3-3, 3-11, 3-15, 5-5, 7-9, 7-11, 7-15, 7-19, 8-7, 8-17, 8-19, 8-25, 8-27, 8-31, 8-43, 11-5, 11-7
A210111000125 Bolt.....	9-3, 10-3	A2104010000002 Washer ..	3-3, 5-7, 6-5, 7-9, 7-11, 14-3
A210111000197 Bolt.....	7-11	A2104010000004 Washer.....	2-5, 5-7, 14-9
A210111000199 Bolt.....	7-11	A2104010000006 Washer.....	5-7
A210111000202 Bolt.....	7-9	A2104010000007 Washer.....	2-5
A210111000203 Bolt.....	7-11, 14-3	A2104010000016 Washer.....	4-9, 4-13, 5-5, 14-7
A210111000204 Bolt.....	7-5	A2104010000017 Washer ...	2-5, 3-9, 4-9, 5-9, 6-3, 7-11, 7-15, 7-19, 8-11, 8-13, 8-21, 8-27, 8-41, 11-3, 13-15, 14-7
A210111000240 Bolt.....	13-7	A2104040000003 Washer.....	5-5, 9-3, 11-5, 11-7
A210111000281 Bolt.....	6-3	A2104040000004 Washer.....	11-5
A210111000282 Bolt.....	6-3	A2104040000005 Washer.....	4-9, 14-7
A210111000283 Bolt.....	4-9	A2104040000008 Washer.....	3-3
A210111000291 Bolt.....	6-3	A2104050000001 Washer ...	3-3, 4-3, 5-7, 6-5, 6-11, 7-5, 7-11, 7-17, 7-19, 10-7, 11-5
A210111000297 Bolt.....	11-7	A2104050000002 Washer.....	8-29
A210111000307 Bolt.....	3-3	A2104050000003 Washer.....	14-9
A210111000343 Bolt.....	7-11	A2104050000004 Washer.....	4-3
A210111000364 Bolt.....	3-3	A2104050000005 Washer.....	3-7, 9-3
A210113000039 Bolt.....	7-5		
A210114000001 Bolt.....	2-5		
A210114000007 Bolt.....	2-3, 2-7		
A210114000012 Bolt.....	2-5		
A210204000017 Screw.....	8-17, 8-25, 8-31		



A210405000006 Washer .....	3-5, 3-13, 4-9, 4-13, 4-15, 5-5, 7-11, 10-3, 14-7	A229900002460 Steering Gear .....	4-7
A210405000007 Washer ...	2-5, 2-7, 2-13, 3-3, 3-9, 4-9, 5-9, 6-3, 7-11, 7-15, 7-19, 8-27, 9-3, 10-3, 10-7, 13-15, 14-7	A229900002724 Slewing bearing .....	6-3
A210405000010 Washer .....	7-19	A229900002752 Fitting, Elbow .....	8-37
A210405000011 Washer.....	2-3, 2-13, 3-3, 3-11, 3-15, 3-17, 4-7, 7-9, 7-11, 7-15, 7-19, 8-17, 8-25, 8-27, 8-29, 10-3, 11-3, 11-5, 11-7	A229900002965 Hose Clamp .....	7-11
A210405000014 Washer .....	7-19	A229900003184 Slewing bearings .....	4-9
A210414000015 Retainer Ring .....	6-7	A229900003542 Mechanical Differential Pressure Indicator .....	7-17
A210414000028 Retainer Ring .....	2-3	A229900003759 T-type Anchor Ear .....	7-15
A210414000037 Retainer Ring .....	6-7	A229900003852 Clip .....	8-33, 8-39, 13-15, 13-19
A210414000065 Retainer Ring .....	2-5	A229900003853 Clamp .....	13-15, 13-21
A210416000006 Ring, Retainer .....	2-3	A229900003898 T-type Anchor Ear .....	7-15
A210416000034 Retainer Ring .....	6-3, 6-5	A229900005421 Shock Pad.....	7-5
A210434000007 Washer .....	2-7	A229900005559 Coat Hook .....	14-7
A210434000010 Washer .....	2-3	A229900009879 Gas Spring .....	14-7
A210434000011 Washer.....	2-7, 6-7	A229900009970 Bolt.....	8-29
A210434000020 Washer .....	2-5	A230101000302 FB Oil Seal.....	2-7
A210453000004 Washer .....	2-7	A230200000026 PTFE glass fiber varnish cloth..	7-15
A210453000007 Washer .....	2-7	A2399000000239 Fiberglass felt strip.....	7-15
A210491000001 Screw .....	14-7	A2499000000600 Cable Connector.....	4-3
A210491000003 Belleville Spring.....	6-3	A249900001139 Secondary Lock 2-wire (Pin) ..	13-11, 13-13, 13-15, 13-17
A210491000009 Pin.....	14-7	A250100000043 Liquid Level Meter.....	10-7
A210491000118 Washer.....	2-3, 2-7, 6-3	A290000002660 Nozzle Universal Protective Cap.....	6-5
A210491000121 Washer .....	2-5, 7-9	A31907100070B Axis Pin .....	14-7
A210491000132 Washer .....	2-3, 6-3, 14-3	A810201060027 Vibration switch valve installation .....	8-5
A210501000043 Pin.....	4-11	A810201060028 Vibration Switch Valve .....	8-31
A210508000067 Pin.....	4-11	A810201206116 Controller Assembly .....	13-7
A210509000037 Key.....	2-3	A820101319357 Crescent Shaped Plate.....	5-7
A210509000088 Key .....	2-9, 2-11	A820101320930 Bent Plate .....	5-7
A210609000009 O-ring .....	6-7	A820101339360 Guard .....	3-5, 6-5
A210609000013 O-ring .....	2-7	A820101342410 Control Valve Body.....	8-41
A210609000035 O-ring .....	2-7, 10-7	A820101345222 Clamp Plate.....	6-5
A210609000038 O-ring .....	8-29, 8-37	A820101348563 Adjusting Block.....	5-7
A210609000041 O-ring .....	8-13	A820101362643 Installation Seat.....	14-9
A210609000062 O-ring .....	6-7	A820102010065 Adjusting Spacer.....	3-3
A210609000174 O-ring .....	2-13	A820201000779 Pressure cover .....	2-7
A210609000284 O-ring .....	2-3	A820202003593 Big Washer.....	7-5, 7-11
A210612000013 Joint Bearing .....	6-3, 6-5	A820203000641 Flange Straight Joint .....	8-15
A210616000012 Spring .....	4-11	A8202050000995 Pipe connector.....	8-13
A210628000009 Rolling bearing.....	2-7	A820205001562 Spacer Plate Joint.....	10-3
A210804000002 Oil Cup.....	2-7, 6-3, 6-5	A820205001582 Fitting.....	5-5
A210855000052 T-type Anchor Ear.....	7-11	A820301010152 Clamp Pin .....	6-11
A210855000066 Hole-type Hose Clamp .....	5-5	A820301012683 Screw Rod, U-type .....	5-5, 7-11
A210891000007 Hinge .....	4-9, 9-3, 14-9	A820301014728 Bolt, Hinged.....	5-7
A219900000089 Handle Ball.....	4-9	A820301017645 Lock Pole .....	14-7
A220400000070 Ball Valve .....	5-5	A820301018783 Shaft, pin.....	3-5, 6-5
A220401000030 Priority Valve .....	8-13	A820606030474 Protecting Ring .....	3-3
A222000000080 Damper.....	4-11	A880804040007 Retainer Ring .....	2-9, 2-11
A222100000044 Air Filter .....	10-7	A880808070038 PWD Dust Ring.....	6-7
A222200000058 Cover Latch Accessories .....	3-13	B210299000005 Screw .....	8-29
A222200000164 Secondary Lock 4-wire Pin ....	13-11, 13-13	B210299000026 Screw .....	8-29
A229900001355 Blbow.....	5-5	B210334000010 Nut.....	8-33
A229900001929 Mechanical Suspension Driver seat.....	4-3	B210399000003 Screw Plug.....	8-11
A229900002031 T-type Anchor Ear.....	7-11	B210780000004 Split Flange .....	8-29
A229900002263 T-type Clamp .....	7-15	B210780000007 Split Flange .....	8-7, 8-37, 8-43
A229900002381 Rain Hat.....	7-15	B210780000008 Square Flange Joint.....	8-29
		B210780000009 Square Flange Joint.....	8-29
		B210780000017 Tee Joint .....	8-33, 8-35
		B210780000018 Tee Joint .....	8-33

B210780000019 Tee Joint .....	8-37	B230101000960 O-ring .....	8-29
B210780000021 Tee Joint .....	8-39	B230101001371 UP Guide Ring.....	6-7
B210780000025 Elbow Fitting.....	3-7, 7-19, 8-7, 8-35, 8-37, 8-45	B230101001492 UP Guide Ring.....	6-7
B210780000028 Elbow Fitting.....	8-33	B230101002124 ZBR Seal Ring.....	6-7
B210780000029 Elbow Fitting.....	8-37, 8-39	B230103000043 Rubber hose.....	7-19
B210780000036 Adapter Fitting .....	8-41	B230103000059 Hose .....	8-33
B210780000037 Adapter Fitting .....	8-25	B230103000066 Hose.....	8-33
B210780000040 Fitting, Adapter .....	7-19, 8-11, 8-25, 8-37	B230103000129 Hose.....	7-19
B210780000043 Fitting.....	8-9	B230103000137 Rubber Hose .....	8-33
B210780000049 Adapter Fitting .....	8-17	B230103000295 Hose .....	8-35
B210780000052 Adapter Fitting .....	8-25	B230103000345 Hose Assembly.....	8-35
B210780000054 Adapter Fitting .....	8-17, 8-25	B230103000712 Hose .....	8-37
B210780000056 Flange Connection.....	8-37	B230103000779 Rubber Hose .....	8-35
B210780000059 Fitting, Elbow.....	8-29	B230103000869 Hose Assembly.....	8-33
B210780000070 Fitting.....	8-27	B230103000949 Hose.....	7-19
B210780000107 End Through Adapter .....	8-29	B230103001057 Rubber Hose .....	8-33
B210780000131 Adapter Fitting .....	8-11, 8-25	B230103001113 Hose .....	8-33
B210780000186 End Straight Adapter .....	8-33	B230103001352 Rubber Hose .....	8-39
B210780000201 Screw Plug.....	8-21, 8-41	B230103001629 Hose .....	8-35
B210780000228 Adapter Fitting .....	8-37, 8-41	B230103001790 Rubber Hose .....	8-37
B210780000232 Adapter Fitting .....	8-23	B230103001881 Rubber Hose .....	8-35
B210780000245 Bulkhead Fitting.....	7-19	B230103002218 Rubber Hose .....	8-33
B210780000266 Adapter Fitting .....	8-13, 8-17, 8-23, 8-35	B230103002298 Rubber hose.....	8-33
B210780000344 Adapter Fitting .....	7-19, 8-15	B230103004027 Hose .....	8-33
B210780000413 Tee Joint .....	8-27	B230103004287 Rubber Hose .....	8-33
B210780000438 Square Flange Right-angle Joint.....	8-19	B230103005096 Rubber Hose .....	8-33
B210780000587 Adapter Fitting .....	8-7, 8-45	B230103005107 Rubber Hose	8-39
B210780000609 Screw Plug.....	8-25, 8-37	4SH20-DKOS-SFS90-3850 .....	8-39
B210780000631 Tee Joint .....	8-39	B230103005108 Rubber Hose .....	8-39
B210780000636 Elbow Fitting.....	7-19, 8-39	B230103005873 Rubber Hose .....	8-33
B210780000652 Square Flange Right-angle Joint.....	8-19	B230103006189 Rubber Hose .....	8-33
B210780000671 End Through Adapter .....	8-29	B230103006195 Hose Assembly.....	8-39
B210780000685 Baffle Adapter.....	8-33	B230103006274 Rubber Hose .....	8-39
B210780000733 Adapter Fitting .....	8-9	B230103006405 Rubber Hose .....	8-33
B210780000824 Fitting, Adapter .....	8-21	B230103007175 Hose Assembly.....	8-35
B210780000829 Adapter Fitting .....	8-39	B230103007493 Rubber Hose .....	7-19, 8-39
B210780000838 Elbow Fitting.....	8-33	B240200000059 Emergency Stop Button.....	13-9
B210780000898 End Through Adapter .....	8-29	B240700000006 Intermediate Relay.....	13-7
B210780001026 Adapter Fitting .....	7-19	B240700000262 Relay .....	13-7
B210780001175 Pressure-measuring Connector.....	8-29	B241200000529 Toggle Switch .....	13-9
B210780001286 Adapter Fitting .....	8-11, 8-13	B241200000530 Toggle Switch .....	13-9
B210780001310 Elbow Fitting.....	8-37	B241200000531 Toggle Switch .....	13-9
B210780001396 Pipe connector.....	8-33	B241200000532 Toggle Switch .....	13-9
B210780001749 Pressure-measuring Fitting.....	8-17	B241200000582 2-core Rectangular Socket .....	13-11, 13-13, 13-15, 13-17
B220400000079 Directional Solenoid Valve .....	8-41	B241200000604 Rectangular Socket.....	13-11, 13-13
B220400000217 Valve, Relief .....	8-21	B241200001124 Ignition Switch.....	13-9
B220401000540 Check Valve .....	8-21	B241300000020 Fuse .....	13-7
B220401001276 Shuttle Valve .....	8-11	B241300000021 Fuse .....	13-7
B221701000095 Flanging Coupling.....	7-9	B241300000022 Fuse .....	13-7
B222100000368 Air Filter .....	7-15	B241300000024 Fuse .....	13-7
B229900002528 Blocked Up.....	13-11, 13-13	B241300000026 Fuse .....	13-7
B230101000138 OK Seal Ring.....	6-7	B249900000288 Pin.....	13-11, 13-13, 13-15, 13-17
B230101000233 O-ring .....	8-15	JSS005350459 Floor leather JRTR07A .....	14-11
B230101000241 O-ring .....	8-15	JSS005361404 Floor welding assembly.....	14-9
B230101000461 O-ring .....	8-7, 8-45	JSS005361405 Cab body .....	14-7
		JSS005361407 Driver's cab welding assy.....	14-9
		JSS005364030 JRTR07A inner&outer-decoration assembly.....	14-7
		JSS006065140 Big cup holder .....	14-7
		JSS006345517 Bracket .....	14-9

JSS006345753 support .....	14-9	YLJ005337392 Clip .....	10-3
JSS006382136 Fan stay Welding Assy. ....	14-9	YLJ005337594 Clip .....	10-3, 10-5
JSS006467729 stiffening plate .....	14-9	YLJ005338651 Clip .....	3-3
SZN007370178 SANY intelligent date		YLJ005340419 bolt .....	3-3
DISPLAY .....	13-9	YLJ005348321 Electrical harness assembly basic	
YLJ004677591 Rearview mirror bracket welding ..	3-9	diagram .....	13-3
YLJ004677594 Rearview mirror bracket .....	3-3	YLJ005348333 Electrical harness in Electric Control	
YLJ004680167 Deputy box manipulation .....	4-15	Cabinet wiring diagram .....	13-23
YLJ004680723 plate .....	4-15	YLJ005348340 Rear Frame Electrical Harness basic	
YLJ004680731 side box .....	4-3	diagram .....	13-23
YLJ004687645 Mounting plate of rearview mirror		YLJ005348359 Front Frame Electrical Harness	
braket .....	3-3	wiring diagram .....	13-23
YLJ004727975 left covering parts .....	9-3	YLJ005348415 Electrical harness of Engine wiring	
YLJ004728021 Covered in a .....	9-3	diagram .....	13-23
YLJ004758616 Mounting Assem. ....	7-15	YLJ005358886 In air .....	7-15
YLJ004776713 Rear Cover Welding .....	4-5	YLJ005358917 In air .....	7-15
YLJ004797181 Oil .....	3-7	YLJ005358995 In air .....	7-17
YLJ004846605 Rotary Support .....	6-3	YLJ005359029 Out air .....	7-11
YLJ004856263 Water Tank .....	12-3	YLJ005359665 In air .....	7-15
YLJ004856829 Hinged body .....	6-3	YLJ005359771 bracket for exhaust hose .....	7-17
YLJ004857847 The left stairs .....	3-3	YLJ005359967 mounting assem. for air	
YLJ004857866 The right stairs .....	3-3	cleaner .....	7-15
YLJ004858317 The Mounting Door .....	3-13	YLJ005393615 hose clip unit .....	10-3
YLJ004858996 Dust Ring .....	6-3	YLJ005417572 Front carriage weld assem. ....	3-3
YLJ004859632 Center hinge frame .....	1-3	YLJ005417704 Front carriage .....	1-3
YLJ004863424 Articulation Seat .....	6-3	YLJ005419735 Water sprinkling tube	
YLJ004895828 Door .....	3-13	component .....	12-3
YLJ004895853 The Maintenance Door .....	3-5	YLJ005426878 plate .....	3-3
YLJ004896675 Bearing cover .....	6-3	YLJ005427066 PLATE .....	3-3
YLJ004897639 Bearing cover .....	6-3	YLJ005563219 vibration drum assem. ....	1-3
YLJ004899560 tube .....	6-5	YLJ005567022 Scraper mounting plate .....	11-7
YLJ004899944 Paper Washer .....	6-3	YLJ005567030 Mounting plate .....	11-7
YLJ004908102 Plate .....	6-3	YLJ005568451 mounting plate welding .....	11-7
YLJ004954617 Diesel box assembly component		YLJ005568781 Scraper mounting plate .....	11-7
.....	3-3	YLJ005568841 mounting plate welding .....	11-7
YLJ004964826 Phone cup .....	14-7	YLJ005573749 Driver's Cab Assy .....	1-3
YLJ005044599 ring .....	3-5	YLJ005602041 air .....	1-3
YLJ005101815 air intake hood .....	10-3	YLJ005619004 rubber retainer .....	10-5
YLJ005103707 rear carriage weld assem. ....	10-3	YLJ005619017 rubber retainer .....	10-5
YLJ005103971 rear frame .....	1-3	YLJ005639941 water .....	1-3
YLJ005105952 Oil road and nearby installation ....	7-3	YLJ005651966 Bridging BeamComponent .....	1-3
YLJ005110427 Cooling assembly .....	7-3	YLJ005652578 Upper scraper assem. ....	11-3
YLJ005110467 Dynamical system .....	1-3	YLJ005683988 Plate .....	7-11
YLJ005110623 Exhaust System .....	7-3	YLJ005720436 Traveling motor .....	8-3
YLJ005110630 Corver .....	9-3	YLJ005770629 cover plate .....	10-3
YLJ005110634 covering parts .....	1-3	YLJ006045976 Cross beam welding .....	11-3
YLJ005336947 Clip .....	3-3	YLJ006231480 Mounting plate of motor .....	7-11
YLJ005336985 Clip .....	3-3	YLJ006552828 plate .....	4-3
YLJ005337130 Clip .....	10-3, 10-5	YLJ006656466 controlling system assembly .....	1-3
YLJ005337280 Clip .....	10-3	YLJ007366684 Rubber tie-plate .....	3-3

[www.sanyglobal.com](http://www.sanyglobal.com)



## **Sany Automobile Manufacturing Co., Ltd.**

SANY Industry Town, Economic and Technological Development Zone, Changsha,  
Hunan, China 410100

Service Hotline: 0086 4006098318

E-mail: [crd@sany.com.cn](mailto:crd@sany.com.cn)





**SANY**

Quality Changes the World

# Tandem Roller

**STR100C-8C**  
**STR130C-8C**  
**STR140C-8C**

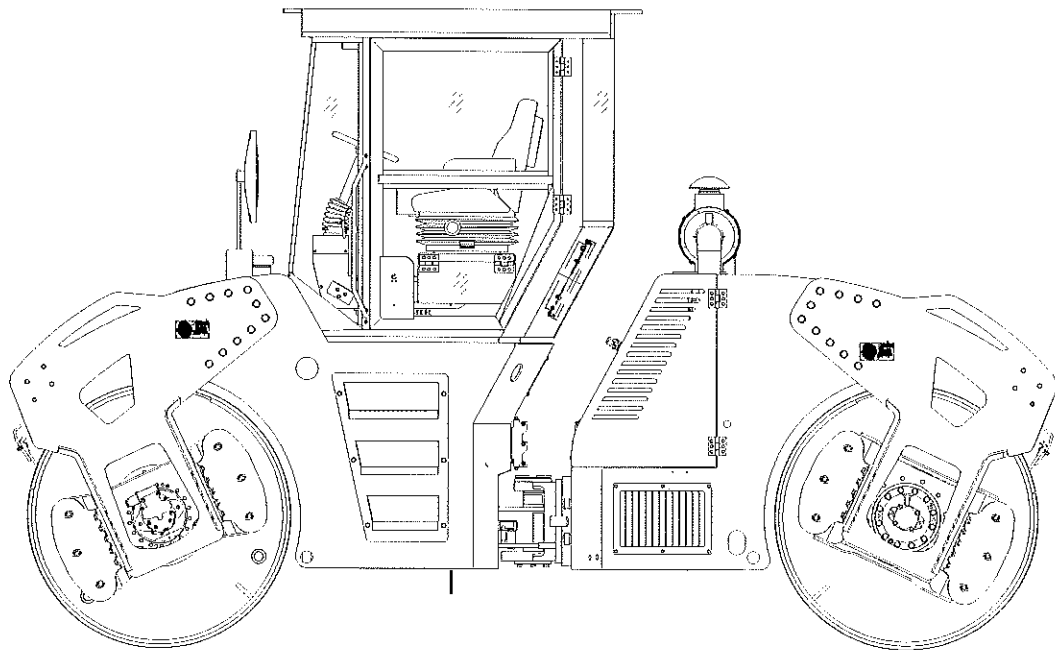

**Safety, Operation & Maintenance Manual**

)

)

)

)

# **SANY**

## **STR100/130/140 Series Tandem Roller**

### **Safety, Operation and Maintenance Manual**



Read and follow the safety precautions and instructions in this manual and on the machine decals. Failure to do so can cause serious injury, death or property damage. Keep this manual with the machine for reading and future reference.

Sany Group  
SANY AUTOMOBILE MANUFACTURING CO., LTD.  
Sany Industry Town,  
Economic & Technological Development Zone  
Changsha, Hunan, China 410100

<http://www.sanyglobal.com>

Service E-mail: [crd@sany.com.cn](mailto:crd@sany.com.cn)  
Service Hotline : 0086 4006 09 8318

Scan here to download the GCP APP



APP for Android & iOS

**! WARNING**

**CALIFORNIA PROPOSITION 65 WARNING**

Diesel engine exhaust and some of its constituents are known to the State of California to cause cancer, birth defects, and other reproductive harm.

**! WARNING**

**CALIFORNIA PROPOSITION 65 WARNING**

The battery posts, terminals, and related accessories contains chemical lead and lead compounds, chemicals known to the State of California to cause cancer, birth defects or other reproductive harm. Wash hands after handling.

© 2020 by Sany Group. All rights reserved. No part of this publication may be reproduced, used, distributed or disclosed except for normal operation of the machine as described herein. All information included within this publication was accurate at the time of publication. Product improvements, revisions, etc., may result in differences between your machine and what is presented here. Sany Group assumes no liability. For more information, contact Sany Group.



## RESPONSIBILITY

### SPECIFIC DECLARATION

The tandem roller is used to compact sand soil and sand gravel in the construction of roads and foundations, which are suitable for most types of road construction, airfields, dam construction and harbor projects. Any other use or any operation beyond the specified working range is not authorized use. Sany expressly bears no liability for any consequence due to any unauthorized use.

Information on this manual is used to guide qualified operators to operate and maintain rollers correctly. Sany expressly bears no liability for any consequence due to any use not observing the information on this manual.

It is forbidden to convert the roller without authorization. Sany expressly bears no liability for any consequence. When crack or electrical malfunction on the roller occurs, please contact the supplier, and don't conduct welding or make changes without permission, or else, for any consequence due to such contravention, Sany shall not bear any liability.

Use genuine spare parts from Sany. Sany expressly bears no liability for any machine damage or accident due to the use of untested or unauthorized spare parts or tools.

Operate and maintain parts (such as engine, a/c) on the roller, and observe related regulations on Users' guide supplied from their manufacturer.

Sany expressly bears no liability for any machine failure or damage due to force majeure of natural disasters (earthquake, typhoon) and wars.

Sany cannot predict every circumstance that might involve a potential hazard in operation or maintenance. Operators and owners should highly attach importance to safety. Local specific safety rules of the countries may be stricter. If they differ from the regulations on this manual, observe the stricter one.

#### Duty of Sany

- Be responsible for providing qualified products and correct documents.
- Fulfill their promises on after-sales service, and document all maintenance and repair working done by after-sales service personnel.
- Train the operation and maintenance personnel based on their needs.

#### Duty of owners or other authorized personnel

- Only after each person involved in the product's operation, maintenance and repair is trained and fully understands the Parts Book and Operation and Maintenance Manual, can they operate and maintain the roller.
- Ensure the operation and maintenance personnel are qualified and know their related responsibilities.

- Periodically check related personnel's safety consciousness during working.
- If any fault which will lead to unsafety occurs, stop the roller immediately.
- If necessary Sany service personnel have the right to check the roller for safety.
- Besides check items regulated by Sany, observe local laws and regulations to check the roller.
- Ensure timely maintenance and repair on the roller.
- Carefully plan the use of the roller.

#### Duty of all working personnel

- If there is any abnormal symptom which may cause abnormal working of the roller or potential hazard, report to your leader. If possible, correct fault in time.
- All personnel working around the roller must observe all warning signals and take care of their own and others' safety.
- All personnel should know their working tasks and procedures.
- Watch something like high voltage wire, unrelated personnel and poor ground for potential danger, and report to the operators and signalmen.

#### Duty of managers

- Ensure the operators are trained and fully understand the Safety, Operation and Maintenance Manual supplied by Sany. Ensure they are in physical fitness and have the certification of operation. Otherwise, it is forbidden to operate the roller.
- Ensure the operators have good judgement ability, teamwork consciousness and psychological quality. Otherwise, it is forbidden to operate or repair the roller.
- Ensure the signalmen have good vision and acoustic judgement, master standard command signals. At the same time, they should have enough experience in recognizing danger factors correctly, and inform the operators of danger factors to avoid them in time.
- Ensure assistant workers can identify the model and working condition to choose a proper roller.
- Publicize safety consciousness to working personnel, and make them aware of safety precautions and their related responsibilities.

# Table of Contents

## 1 Introduction

1.1 Overview .....	1-1
1.2 Your Documentation Package .....	1-2
1.2.1 Recommendations on Using the Documentation .....	1-2
1.2.2 Documentation Storage .....	1-2
1.2.3 Organization of this Manual .....	1-2
1.2.3.1 Introduction .....	1-3
1.2.3.2 Safty .....	1-3
1.2.3.3 System Functions .....	1-3
1.2.3.4 Operation .....	1-3
1.2.3.5 Maintenance .....	1-3
1.2.3.6 Troubleshooting .....	1-3
1.2.3.7 Technical Specifications .....	1-4
1.3 Your SANY Equipment .....	1-4
1.3.1 Equipment Directions .....	1-4
1.3.2 Breaking in a New Equipment .....	1-4
1.3.3 Equipment Information .....	1-5
1.3.4 Serial Number and Distributor Information .....	1-6
1.4 Contact Information .....	1-7

## 2 Safety

2.1 General .....	2-1
2.1.1 Intended Use .....	2-3
2.1.2 Unintended Use .....	2-3
2.1.3 Qualifications of Operators and Maintainers .....	2-3
2.1.4 Unauthorized Modification .....	2-4
2.2 Safety Message .....	2-4
2.2.1 Safety Message Introduction .....	2-4
2.2.2 Safety Message Locations .....	2-5
2.2.3 Signal Words .....	2-6
2.2.4 An Example of Signal Words .....	2-6
2.2.5 Safety Decals .....	2-7
2.2.5.1 Safety Words .....	2-7

2.2.5.2 Safety Symbols	2-7
2.3 General Precautions	2-14
2.3.1 Safety Rules	2-14
2.3.2 Abnormal Case	2-14
2.3.3 Safety Devices	2-14
2.3.4 Protective Measures for Personal Safety	2-15
2.3.5 Precautions against Emergency	2-16
2.3.5.1 Use the Emergency Stop Switch Correctly	2-16
2.3.5.2 Evacuation in Fire Accident	2-17
2.3.5.3 Touching High-voltage Lines	2-17
2.3.5.4 Falling Object Protection	2-18
2.4 Precautions During Operation	2-18
2.4.1 Safe Starting	2-18
2.4.1.1 Safe Mounting	2-18
2.4.1.2 Seat Adjusting	2-18
2.4.1.3 Seat Belt	2-19
2.4.1.4 Before Starting the Engine	2-19
2.4.1.5 Engine Starting	2-20
2.4.1.6 After Starting the Engine	2-21
2.4.2 Safety Operation	2-22
2.4.2.1 Surveying the Worksite in Advance	2-22
2.4.2.2 Before Operation	2-23
2.4.2.3 Safe Traveling	2-24
2.4.2.4 Safe Turning	2-27
2.4.2.5 Safe Vibrating	2-27
2.4.3 Safe Parking	2-28
2.4.3.1 Requirements for Parking Area	2-28
2.4.3.2 Parking Rules	2-28
2.5 Maintenance Precautions	2-29
2.5.1 Basic Rules	2-29
2.5.2 Lockout/Tagout Procedures	2-29
2.5.3 Working Area Preparation	2-30
2.5.4 Washing the Equipment	2-31
2.5.5 Self-preparation	2-31
2.5.6 Proper Tool	2-32
2.5.7 Maintenance with Engine Running	2-32
2.5.8 Working under the Roller	2-33

2.5.9 Working in Noisy Environment .....	2-34
2.5.10 Removing Paint before Welding or Heating .....	2-34
2.5.11 Correct Welding .....	2-34
2.5.12 No Heating beside Hydraulic Pipeline .....	2-34
2.5.13 No Heating the Pipes with Combustible Liquid .....	2-36
2.5.14 Correctly Operating the Hydraulic System .....	2-36
2.5.15 Being Aware of High-pressure Liquid .....	2-37
2.5.16 Regularly Replacing the Rubber Hoses .....	2-38
2.5.17 Avoid Scald by High-temperature Liquid .....	2-38
2.5.18 Preventing Battery from Explosion .....	2-39
2.5.19 Preventing Components from Flying out .....	2-40
2.5.20 Safe Storage of Parts .....	2-40
2.5.21 Safe Treatment of Liquid .....	2-40
2.5.22 Safe Treatment of Chemicals .....	2-41
2.5.23 Proper Disposal of Wastes .....	2-41
2.6 Safe Transportation .....	2-42
2.6.1 Load/Unload the Roller .....	2-42
2.6.2 Transport the Roller .....	2-43
2.6.3 Lift the Roller .....	2-43

### 3 System Functions

3.1 General Description .....	3-2
3.2 Display and Control Console .....	3-2
3.2.1 Display .....	3-3
3.2.2 Switches .....	3-18

### 4 Operation

4.1 Check before Starting the Engine .....	4-1
4.1.1 Inspection (walk-around) .....	4-1
4.1.2 Inspection before Starting .....	4-2
4.1.2.1 Check the Engine Oil Level .....	4-2
4.1.2.2 Check the Engine Coolant Level .....	4-3
4.1.2.3 Check the Oil Water Separator .....	4-3
4.1.2.4 Check the Hydraulic Oil Level .....	4-4
4.1.2.5 Check the Washer .....	4-5
4.1.2.6 Check the Air Filter .....	4-5
4.1.2.7 Check the Water Tank .....	4-6

4.1.2.8	Check the Water Filter Element	4-6
4.1.2.9	Check the Tire Pressure	4-7
4.1.2.10	Check the Position of Limit Pin	4-7
4.1.2.11	Check the Vibratory Drum and Dampers	4-7
4.1.2.12	Check the Electric Wires	4-8
4.2	Adjustments Prior to Startup	4-8
4.2.1	Seat Adjustment	4-8
4.2.2	Rearview Mirror Adjustment	4-8
4.3	Equipments Checking Prior to Startup	4-9
4.3.1	Power on the Control System	4-9
4.3.2	Check the Fuel Level	4-10
4.3.3	Check the Propel Control Lever	4-11
4.3.4	Check the Emergency Stop Switch	4-12
4.3.5	Check the Parking Brake Switch	4-12
4.3.6	Check the Switches (If Any)	4-12
4.4	Engine Starting	4-14
4.4.1	Normal Start	4-14
4.4.2	Jump-start	4-15
4.5	After Engine Starting	4-19
4.6	Test Running	4-20
4.7	Travel Operation	4-21
4.7.1	Travel forward	4-21
4.7.2	Travel reverse	4-22
4.7.3	Steering	4-22
4.7.4	Switching the Speed Gear	4-22
4.8	Vibration Operation	4-23
4.8.1	Vibration Mode and Switching	4-23
4.8.1.1	Manual Mode	4-23
4.8.1.2	Auto Mode	4-23
4.8.1.3	Switching the Vibration Mode	4-23
4.8.2	Vibration Frequency and Switching	4-24
4.8.2.1	High Frequency	4-24
4.8.2.2	Low Frequency	4-24
4.8.2.3	Switching the Vibration Frequency	4-24
4.8.2.4	Selecting Frequency according to the Road Condition	4-25
4.8.3	Vibration	4-25
4.8.3.1	Vibration in Manual Mode	4-25

4.8.3.2 Vibration in Auto Mode .....	4-27
4.9 Parking Operation .....	4-27
4.9.1 Service Brake .....	4-27
4.9.2 Parking brake .....	4-28
4.9.3 Emergency Brake .....	4-29
4.10 Crablike Travel Operation .....	4-30
4.11 Correct Operation for Water Spraying System .....	4-30
4.11.1 Manual Water Spraying Mode .....	4-32
4.11.2 Auto water spraying mode .....	4-32
4.12 Check after Each Work Day .....	4-33
4.13 Correct Driving According to the Road Condition .....	4-33
4.13.1 Working near Ditch Edge and Road Shoulder .....	4-33
4.13.2 Working near Buildings Vulnerable to Vibration .....	4-34
4.13.3 Working on the Slope .....	4-34
4.14 Other Auxiliary Equipments .....	4-35
4.14.1 Wiper .....	4-35
4.14.2 Radio Operation .....	4-36
4.14.3 Working Lights .....	4-38
4.15 Transportation .....	4-38
4.15.1 Transport Vehicle .....	4-38
4.15.2 Using a Slope .....	4-38
4.15.3 Shipping .....	4-40
4.15.3.1 Container Shipping .....	4-40
4.15.3.2 Non-container Shipping .....	4-44

## 5 Maintenance

5.1 Maintenance information .....	5-1
5.1.1 Notes on Maintenance .....	5-1
5.1.2 Notes on Engine Performance .....	5-1
5.1.3 Notes on Fuel System .....	5-2
5.1.4 Notes on Hydraulic System .....	5-2
5.2 Requirements on use of oil & fluids .....	5-3
5.2.1 Introduction of functional oil & fluids .....	5-3
5.2.1.1 Engine Oil .....	5-3
5.2.1.2 Fuel .....	5-4
5.2.1.3 Lubricant .....	5-5
5.2.1.4 Grease .....	5-5

5.2.1.5 Coolant .....	5-5
5.2.2 Oil & Fluids Selection .....	5-6
5.2.2.1 General requirements .....	5-6
5.2.3 Filling capacities .....	5-12
5.3 Test Run Instructions .....	5-13
5.4 Maintenance .....	5-14
5.5 Daily Maintenance .....	5-15
5.5.1 Clean .....	5-16
5.5.1.1 Roller .....	5-16
5.5.1.2 Air Filter .....	5-16
5.5.2 Check .....	5-17
5.5.2.1 Safety, Operation & Maintenance Manual .....	5-17
5.5.2.2 Operating Functions .....	5-17
5.5.2.3 Lamps and Horn .....	5-17
5.5.2.4 Air Filter .....	5-18
5.5.2.5 Engine Air Intake Pipeline .....	5-22
5.5.2.6 Engine Oil Level .....	5-22
5.5.2.7 Engine Coolant Level .....	5-22
5.5.2.8 Engine Belt .....	5-23
5.5.2.9 A/C System .....	5-25
5.5.2.10 Hydraulic Oil Level .....	5-27
5.5.2.11 Fuel Level .....	5-27
5.5.2.12 Electrical System .....	5-28
5.5.2.13 Oil/water Spraying System .....	5-30
5.5.2.14 Oil Tank and Oil Lines .....	5-30
5.5.2.15 Oil Leaks .....	5-30
5.5.2.16 Drums and Dampers .....	5-30
5.5.2.17 Connections and Tightness .....	5-31
5.5.2.18 Washer .....	5-31
5.5.3 Drain-Oil Water Separator .....	5-23
5.6 Initial 50 Hour Maintenance .....	5-34
5.6.1 Securing Machine for Maintenance .....	5-34
5.6.2 Change .....	5-35
5.6.2.1 Engine Oil .....	5-35
5.6.2.2 Engine Oil Filter .....	5-37
5.6.2.3 Fuel Filter .....	5-38
5.6.2.4 Oil Water Separator Element .....	5-39



5.6.2.5 Lubricant for Drums .....	5-40
5.6.2.6 Lubricant for Reducer .....	5-41
5.6.3 Check .....	5-42
5.6.3.1 Engine Belt .....	5-42
5.6.3.2 Compressor Belt .....	5-42
5.7 Initial 250 Hour Maintenance .....	5-43
5.7.1 Securing Machine for Maintenance .....	5-43
5.7.2 Replace .....	5-44
5.7.2.1 Lubricant for Drums .....	5-44
5.7.2.2 Lubricant for Reducer .....	5-44
5.8 Initial 500 Hour Maintenance .....	5-44
5.8.1 Securing Machine for Maintenance .....	5-44
5.8.2 Maintenance .....	5-45
5.9 Every 250 Hour Maintenance .....	5-45
5.9.1 Replace .....	5-46
5.9.1.1 Engine Oil .....	5-46
5.9.1.2 Engine Oil Filter Element .....	5-46
5.9.1.3 Fuel Filter .....	5-47
5.9.1.4 Oil Water Separator Element .....	5-47
5.10 Every 500 Hour Maintenance .....	5-48
5.10.1 Add lubricant .....	5-49
5.10.2 Replace .....	5-49
5.10.2.1 Air Filter Main Element/Safety Element .....	5-49
5.10.2.2 Lubricant for Drums .....	5-50
5.10.2.3 Lubricant for Drums .....	5-50
5.10.3 Check .....	5-50
5.10.3.1 Key Welding parts, Driving Parts .....	5-50
5.10.3.2 Dampers .....	5-50
5.11 Every 1000 Hour Maintenance .....	5-51
5.11.1 Check/maintain-A/C .....	5-51
5.11.2 Replace .....	5-56
5.11.2.1 Hydraulic Oil .....	5-56
5.11.2.2 Hydraulic Oil Filter Element .....	5-57
5.11.2.3 Coolant .....	5-58
5.12 Other Maintenance Items .....	5-60
5.12.1 Clean the Fuel Tank .....	5-60
5.12.2 Clean the Radiator .....	5-61

5.13 Maintenance for Long-time Stored Roller ..... 5-63  
 5.13.1 Engine ..... 5-63  
 5.13.2 the Roller ..... 5-64  
 5.14 Antifreezing Maintenance ..... 5-65  
 5.15 Check after Maintenance ..... 5-66

**6 Troubleshooting**

6.1 Mechanical Parts ..... 6-1  
 6.1.1 Engine ..... 6-1  
 6.1.2 Vibratory Drum ..... 6-3  
 6.1.3 Propel system ..... 6-4  
 6.1.4 Brake ..... 6-5  
 6.2 Typical Hydraulic Elements ..... 6-6  
 6.2.1 Axial Plunger Pump ..... 6-6  
 6.2.2 Axial Plunger Motor ..... 6-10  
 6.2.3 Change Valve ..... 6-12  
 6.2.4 Overflow Valve ..... 6-16  
 6.2.5 Steering Cylinder ..... 6-20  
 6.2.6 Oil Filter ..... 6-25  
 6.2.7 Sealing Elements ..... 6-26  
 6.2.8 Hydraulic Steering Gear ..... 6-28  
 6.3 Electrical Parts ..... 6-30  
 6.3.1 Basic Electrical System ..... 6-30  
 6.3.2 Electrical System of Working Devices ..... 6-32  
 6.3.3 Fuses ..... 6-33  
 6.3.4 Radio ..... 6-34  
 6.4 Air Conditioning System ..... 6-35  
 6.4.1 System with Poor Cooling ..... 6-35  
 6.4.2 Insufficient System Cooling ..... 6-36  
 6.4.3 Abnormal Noise Caused by Cooling System ..... 6-38  
 6.4.4 Air Heating Device Fault ..... 6-39  
 6.4.5 Other Faults ..... 6-39  
 6.5 Troubleshooting Examples ..... 6-41

**7. Specifications**

7.1 Dimension of the Equipment ..... 7-1  
 7.2 Specifications of the Equipment ..... 7-2





# SANY

## Introduction

### 1 Introduction

1.1 Overview .....	1-1
1.2 Your Documentation Package .....	1-2
1.2.1 Recommendations on Using the Documentation .....	1-2
1.2.2 Documentation Storage .....	1-2
1.2.3 Organization of this Manual .....	1-2
1.2.3.1 Introduction .....	1-3
1.2.3.2 Safty .....	1-3
1.2.3.3 System Functions .....	1-3
1.2.3.4 Operation .....	1-3
1.2.3.5 Maintenance .....	1-3
1.2.3.6 Troubleshooting .....	1-3
1.2.3.7 Technical Specifications .....	1-4
1.3 Your SANY Equipment .....	1-4
1.3.1 Equipment Directions .....	1-4
1.3.2 Breaking in a New Equipment .....	1-4
1.3.3 Equipment Information .....	1-5
1.3.4 Serial Number and Distributor Information .....	1-6
1.4 Contact Information .....	1-7

 **WARNING**

**Read and understand all safety precautions and instructions in this manual before reading any other manuals provided with this roller and before operating or servicing the roller. Failure to do this can cause property damage, personal injury or death.**

---

## 1 INTRODUCTION

### 1.1 Overview

- SANY-built equipment offers high-quality performance and excellent aftersales service support.
- SANY-built equipment is widely used throughout the industry for various types of applications.
- SANY is a leading manufacturer of heavy construction equipment worldwide.

This operator's manual provides safety, operation, maintenance, troubleshooting and specifications. In order to properly use your equipment, it is important to read and understand this manual before using the equipment.

Items addressed in this manual are designed to help you:

- Understand the structure and performance of your equipment.
- Reduce improper operation and point out possible hazardous situations when using equipment.
- Increase equipment efficiency during operation.
- Prolong the service life of your equipment.
- Reduce maintenance costs.

Always keep this manual nearby and have all personnel involved with any work operations read it periodically. If this manual becomes damaged or lost and cannot be read, it is advised to request a replacement copy from your SANY distributor as soon as possible. If you sell the equipment, be sure to give this manual to the new owner.

Continuing improvements in the design can lead to changes in details which may not be reflected in this manual. Always consult your SANY distributor for the latest available

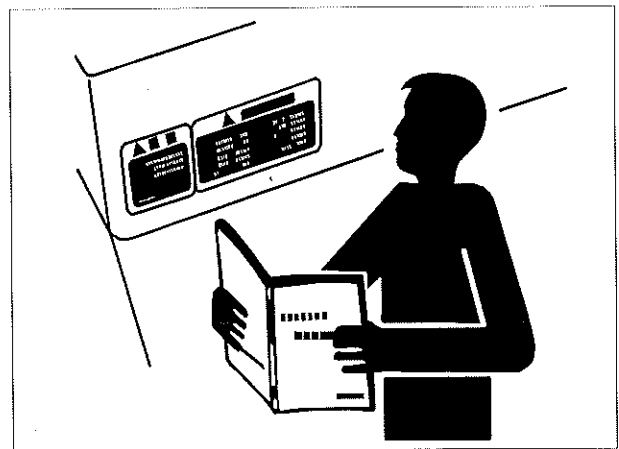

Fig.1-1

information on your equipment or if you have questions regarding information in this manual.

## **1.2 Your Documentation Package**

The documentation includes:

- Safety, Operation and Maintenance Manual.
- Parts Book– including the Parts List and the Drawings needed when ordering parts. If the Parts Book is not attached with the equipment, contact SANY.

### **1.2.1 Recommendations on using the documentation**

- The documents only apply to this equipment, and should not be used with any other equipments.
- Ensure that the documents are complete and up to date.
- Put all data in a folder (if including leaflets).
- Print and replace the lost, damaged and blotted pages.
- Add the latest SANY data in time and destroy the inapplicable old documents.

### **1.2.2 Documentation storage**

Always keep this manual with the equipment in the cab. The Parts Book is best left either shelved in the workshop area or office. It should always be available to the maintenance and service personnel as required.

### **1.2.3 Organization of this manual**

This manual covers operation and maintenance of your equipment. Get familiar with it before performing any operations. Put this manual within easy reach for your reference and replace it if it is lost or damaged. Due to improvement and updating of products, some information may differ from your equipment. If you have any question on the use and maintenance of your equipment, contact your SANY distributor.



### **1.2.3.1 Introduction**

This section provides an overview of what is covered in the rest of this manual, including equipment label information and SANY contact information.

### **1.2.3.2 Safety**

This section covers basic safety information relating to this equipment. Make sure you fully understand all the precautions described in this manual and the safety decals on the equipment before operating or maintaining this equipment. Failure to do so may result in serious injury or death.

### **1.2.3.3 System functions**

This section provides an overview of all the controls and prompt & operating systems on your equipment. Only when you are familiar with all systems, can you operate and maintain the equipment safely.

### **1.2.3.4 Operation**

This section provides the basic operating procedures for the equipment. It is important to study and become familiar with all procedures before performing any operations with the equipment.

### **1.2.3.5 Maintenance**

This section provides all general maintenance and repair procedures. It is important to study and become familiar with all the maintenance and repair procedures before performing any maintenance or repair operations on the equipment.

### **1.2.3.6 Troubleshooting**

This section includes common malfunctions and fault diagnostic procedures for the operating system of this tandem roller. The basic troubleshooting methods for mechanical, hydraulic and electrical systems are included.

### 1.2.3.7 Specifications

This section provides the general information about this equipment. Some information may change as design modification.

## 1.3 Your SANY Equipment

### 1.3.1 Equipment directions

- (A) Front
- (B) Back
- (C) Left
- (D) Right

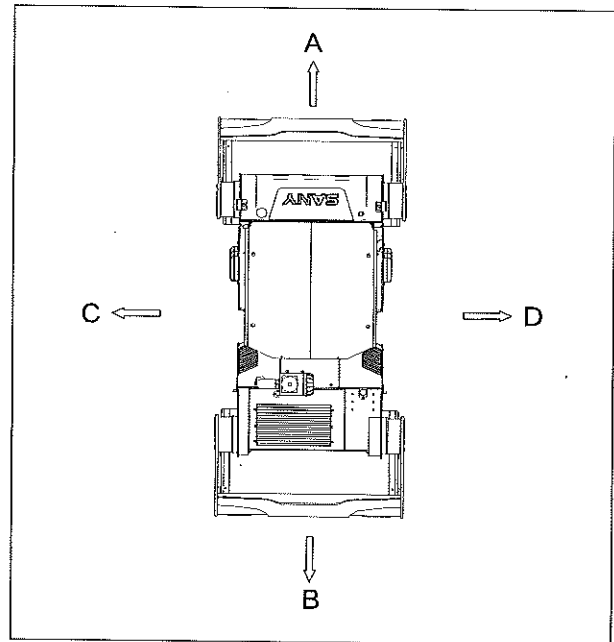

Fig.1-2

### 1.3.2 Breaking in a new equipment

Your equipment has been well adjusted and tested before delivery. However, initial operation on the equipment in severe conditions will seriously affect the performance or reduce the service life of the equipment. Thus SANY recommends you to perform 100-hour test run before putting the equipment into production use.

During the break-in period:

- Let the equipment warm up prior to any operation.
- Avoid operating or running the equipment at a high speed in overload working conditions.
- Avoid sudden starting, rapid movement or abrupt stop of the equipment.
- Cool down the equipment system at the end of every working day.

### 1.3.3 Equipment information

The serial numbers and model numbers on the components are the only identification that your SANY distributor will need when ordering replacement parts or requiring assistance for your equipment. You can find the related information on the nameplate. It is a good idea to record this information in this manual for future use.

Product nameplate (a) is riveted on the left side of the frame(See Fig.1-3).

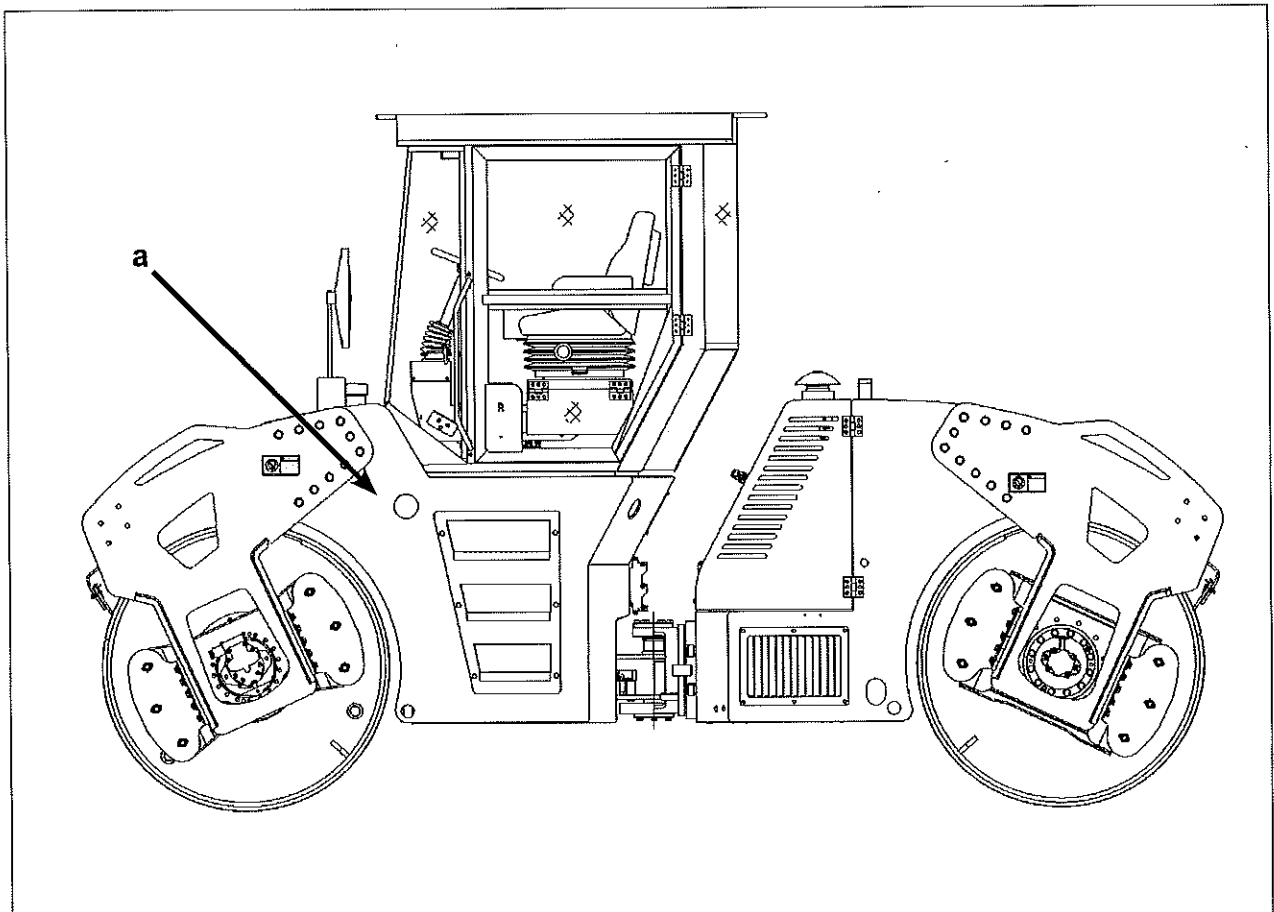

Fig.1-3

1.3.4 Serial number and distributor information

This location is for you to record information relating to your equipment. It is advised that you keep this manual with your equipment at all times for reference.

<b>Product Type</b>	
<b>Serial No.</b>	
<b>Date of Production</b>	
<b>Vehicle Identification Number (V.I.N.)</b>	

**Distributor Name:**

**Address:**

**Phone Numbers:**

## 1.4 Contact Information

Thank you for purchasing a SANY product. In the event that you need to contact us for any reason, you can reach us as follows.

Our address:

Sany Industry Town, Changsha National  
Economic & Technical Development Zone,  
Hunan, China 410100

Tel: 0086 4006098318

Email: [crd@sany.com.cn](mailto:crd@sany.com.cn)

Blank page with horizontal dashed lines for writing.

BLANK PAGE

# SANY

## Safety

### 2 Safety

2.1 General	2-1
2.1.1 Intended Use	2-3
2.1.2 Unintended Use	2-3
2.1.3 Qualifications of Operators and Maintainers	2-3
2.1.4 Unauthorized Modification	2-4
2.2 Safety Message	2-4
2.2.1 Safety Message Introduction	2-4
2.2.2 Safety Message Locations	2-5
2.2.3 Signal Words	2-6
2.2.4 An Example of Signal Words	2-6
2.2.5 Safety Decals	2-7
2.2.5.1 Safety Words	2-7
2.2.5.2 Safety Symbols	2-7
2.3 General Precautions	2-14
2.3.1 Safety Rules	2-14
2.3.2 Abnormal Case	2-14
2.3.3 Safety Devices	2-14
2.3.4 Protective Measures for Personal Safety	2-15
2.3.5 Precautions against Emergency	2-16
2.3.5.1 Use the Emergency Stop Switch Correctly	2-16
2.3.5.2 Evacuation in Fire Accident	2-17
2.3.5.3 Touching High-voltage Lines	2-17
2.3.5.4 Falling Object Protection	2-18
2.4 Precautions During Operation	2-18

2.4.1 Safe Starting	2-18
2.4.1.1 Safe Mounting	2-18
2.4.1.2 Seat Adjusting	2-18
2.4.1.3 Seat Belt	2-19
2.4.1.4 Before Starting the Engine	2-19
2.4.1.5 Engine Starting	2-20
2.4.1.6 After Starting the Engine	2-21
2.4.2 Safety Operation	2-22
2.4.2.1 Surveying the Worksite in Advance	2-22
2.4.2.2 Before Operation	2-23
2.4.2.3 Safe Traveling	2-24
2.4.2.4 Safe Turning	2-27
2.4.2.5 Safe Vibrating	2-27
2.4.3 Safe Parking	2-28
2.4.3.1 Requirements for Parking Area	2-28
2.4.3.2 Parking Rules	2-28
2.5 Maintenance Precautions	2-29
2.5.1 Basic Rules	2-29
2.5.2 Lockout/Tagout Procedures	2-29
2.5.3 Working Area Preparation	2-30
2.5.4 Washing the Equipment	2-31
2.5.5 Self-preparation	2-31
2.5.6 Proper Tool	2-32
2.5.7 Maintenance with Engine Running	2-32
2.5.8 Working under the Roller	2-33
2.5.9 Working in Noisy Environment	2-34
2.5.10 Removing Paint before Welding or Heating	2-34
2.5.11 Correct Welding	2-34
2.5.12 No Heating beside Hydraulic Pipeline	2-35
2.5.13 No Heating the Pipes with Combustible Liquid	2-36
2.5.14 Correctly Operating the Hydraulic System	2-36
2.5.15 Being Aware of High-pressure Liquid	2-37
2.5.16 Regularly Replacing the Rubber Hoses	2-38
2.5.17 Avoid Scald by High-temperature Liquid	2-38
2.5.18 Preventing Battery from Explosion	2-39
2.5.19 Preventing Components from Flying out	2-40
2.5.20 Safe Storage of Parts	2-40



2.5.21 Safe Treatment of Liquid ..... 2-40  
2.5.22 Safe Treatment of Chemicals ..... 2-41  
2.5.23 Proper Disposal of Wastes ..... 2-41  
2.6 Safe Transportation ..... 2-42  
2.6.1 Load/Unload the Roller ..... 2-42  
2.6.2 Transport the Roller ..... 2-43  
2.6.3 Lift the Roller ..... 2-43

 **WARNING**

**Read and understand all safety precautions and instructions in this manual before reading any other manuals provided with this roller and before operating or servicing the roller. Failure to do this can cause property damage, personal injury or death.**

---

## 2 SAFETY

### 2.1 General

This Safety, Operation and Maintenance Manual is a guide for you to operate your equipment properly.

It contains technical and safety information necessary for operation of your equipment. Read and understand each section of the manual.

Always operate your equipment according to national, provincial, prefectural and municipal laws and regulations. The safety information for operation in this manual are just suggestive.

SANY cannot anticipate every possible circumstance that might involve a potential hazard during operation and maintenance. The safety messages in this manual and on the product are, therefore, not all inclusive. If a procedure, work method or operating technique that is not specifically recommended in this manual is used, you must be sure that it is safe for you and for others. You should also ensure that the product will not be damaged or be made unsafe by the operation, lubrication, maintenance or repair procedures that you choose.

Equipments covered by this manual are used for various operations under normal conditions.

Never use the equipment in flammable or explosive environment, or in areas containing asbestos dust.

Select a SANY tandem roller with a configuration suitable for high-plateau operation when operating in areas 2000 meters above the sea level.

The information, specifications, and illustrations in this publication are on the basis of information that was available at the time that the publication was written. SANY reserves the

right to change these information at any time without prior notice. Consult SANY distributor to obtain the latest information or if you have any question on the information provided in this manual.

Before starting operation and maintenance, operator and maintainer shall observe the following items.

- Read and understand the whole manual.
- Read and understand the safety notices contained in this manual and the safety messages on the equipment.
- Never apply or operate your equipment under any circumstances in a manner that is prohibited in this manual.
- If the amount of fuel added, content of particulates ,or latitude is beyond the specification of this type of equipment, damage could occur and the warranty of your equipment would become invalid.



Fig.2-1

The manual should be kept in the cabin all the time for operator to refer to at any time. Contact SANY distributor to obtain a new manual if the original one is missing or cannot be read.

This manual should be regarded as a permanent component of your equipment. If the equipment is sold to a third party, give this manual to the new owner. The equipment provided by SANY Road Machinery Co., Ltd to its buyer is in line with all specifications and standards of buyer's country. If the equipment is purchased from another country or someone of a third country, it might be lacking of some safety devices or technical requirements necessary for using the equipment in your country. In case you question whether the equipment is in accordance with the standards and specifications of your country, contact SANY distributor before operating the equipment.

### 2.1.1 Intended use

The equipment is mainly designed for the following operations.

- Compacting different kinds of pavements, such as various of non-viscous soil (including sandy soil, gravel and so on), detritus, stone and rock.
- Compacting work on earth and stone foundations of road, airport, dam and so on.

### 2.1.2 Unintended use

- Operation by untrained personnel in an unprofessional manner or using the equipment for purposes unmentioned in this manual may pose hazard.
- Avoid starting vibration on asphalt pavement and pavement with thick ice.
- Avoid starting and operating the equipment in an explosive environment.

### 2.1.3 Qualifications of operators and maintainers

- The equipment can only be operated by trained and authorized persons who are at least 18 years old.
- The operator must fully understand and observe the operation rules of the equipment.
- Persons under the influence of alcohol, medication or drugs are not allowed to operate, service or repair the equipment.
- Only trained and qualified personnel can carry out maintenance and repair tasks of the equipment.



Fig.2-2

### **2.1.4 Unauthorized modification**

Any modification to the machine without authorization from SANY may have an adverse effect on the machine's performance or pose more serious hazard. Improper operation or unauthorized application may lead to equipment failure, personal injury or possible death. SANY assumes no responsibility for such losses.

## **2.2 Safety Message**

The following warning decals and safety messages are used on the machine.

- Make sure that you get familiar with the locations and information of all safety decals on the machine.
- All warning decals must be placed in the proper locations on the machine. They must be kept clean for readability. Never use organic solvent or gasoline to clean the warning decals, which may cause the paints on the safety decal to fall.
- Other signs are also on the machine besides safety decals and safety messages, which must be kept clean and intact.
- Use a new safety decal or safety message in a timely manner to replace the old one which is damaged or missing.

### **2.2.1 Safety message introduction**

For using the machine safely and properly, this manual has provided you with the detailed illustrations to the decals on the machine to make you be aware of potential hazards and prevent the hazards.

All operators or maintenance personnel involved with the use of this machine must read this manual thoroughly and fully understand the safety message on the machine prior to operating or maintaining this machine. Strictly

observe the safety rules provided in this manual to avoid personal injury and damage to the machine.

### 2.2.2 Safety message locations

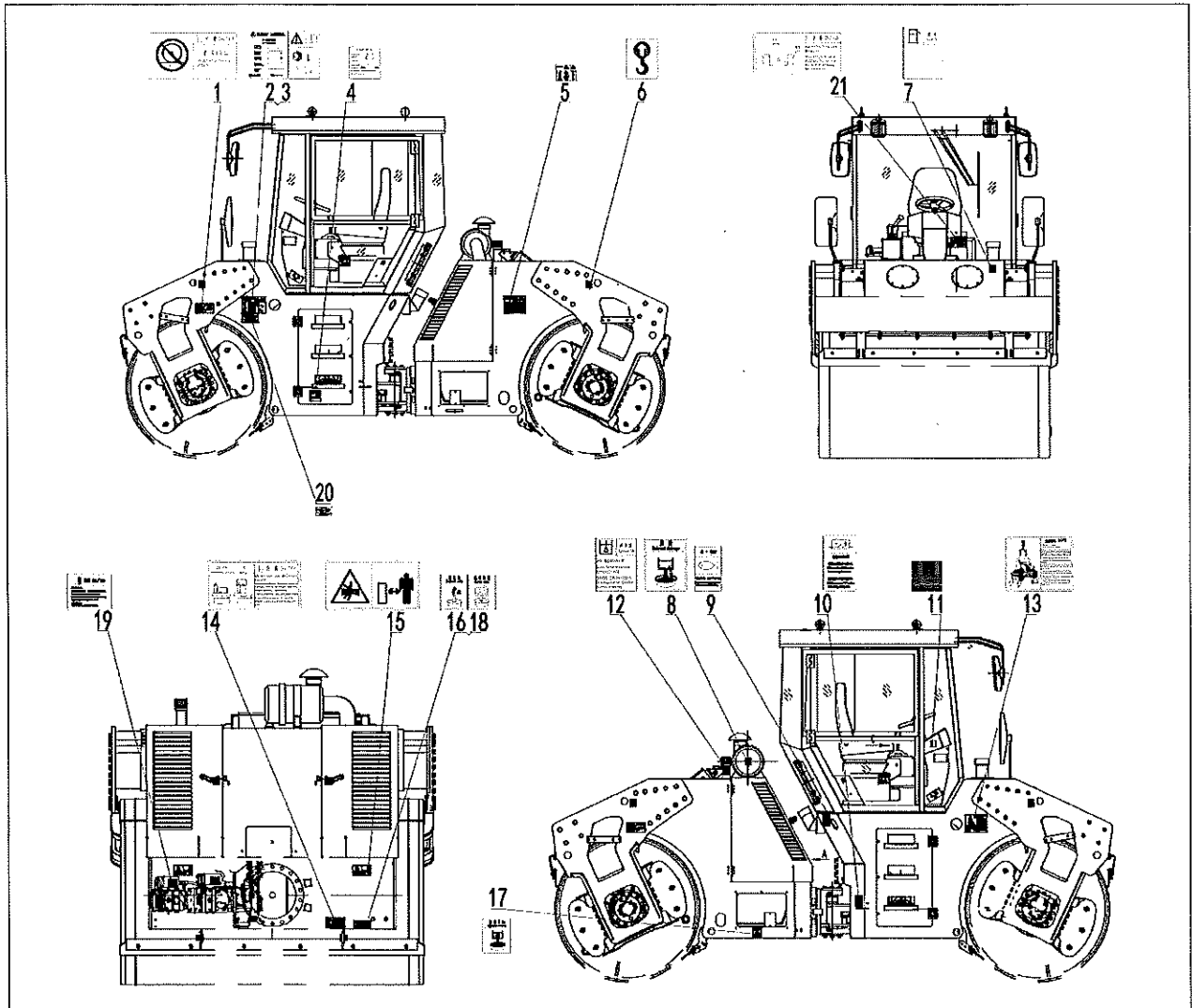

- |                               |   |                               |
|-------------------------------|---|-------------------------------|
| 1- Vibration alarm plate      | 9- Water tank indication                              | 17- Hydraulic oil draining    |
| 2- Nameplate                  | 10- Power switch                                      | 18- Water drainage            |
| 3- Read the manual & Noise    | 11- Sany Wechat QR-code                               | 19- Filter core warning       |
| 4- Water spraying notice      | 12- Hydraulic oil tank indication                     | 20- Environmental information |
| 5- Lubrication points map     | 13- Lifting instruction                               | 21- A/C adjustment warning    |
| 6- Lift point                 | 14- Locating pin warning of central articulated frame |                               |
| 7- Diesel oil tank indication | 15- Keep away   |                               |
| 8- Sediment drainage          | 16- Engine oil draining                               |                               |





Fig.2-3

**2.2.3 Signal words**

The following signal words are used to inform you there may be potential dangers that lead to personal injury or damage.

In this manual and on the machine decals, different signal words or illustrations are used to express the potential level of hazard.

Table 2-1 Safety Decal and Explanation

Safety Decal	Explanation
 <b>DANGER</b>	Indicates an imminent hazard which, if not avoided, will result in serious injury or death.
 <b>WARNING</b>	Indicates a potentially hazardous situation which, if not avoided, could result in injury or possibly death.
 <b>CAUTION</b>	Indicates a possible potential hazardous situation which, if not avoided, could result in minor or major injury.
<b>NOTICE</b>	Indicates a situation which can cause damage to the equipment, personal property and/or the environment, or cause the equipment to operate improperly.
	This hazard alert symbol appears with most hazard alerts. It means attention, become alert, your safety is involved! Please read and abide by the message that follows the hazard alert symbol.
	Indicate the operation disobeys the safety regulations, which may cause personal injury or death and is prohibited.

**2.2.4 An example of signal words**

**NOTICE**

**If the hydraulic oil level is found to have dropped during the daily check, check all lines and hydraulic elements for leaks, or it may cause failure in operation and environment pollution.**



## 2.2.5 Safety decals

Safety signs are fixed to the equipment, which are used to alert local operator or maintenance workers that potential danger might be involved when operating or servicing the equipment.

The equipment uses "safety words" and "safety symbols" to indicate safety measures.

### 2.2.5.1 Safety words

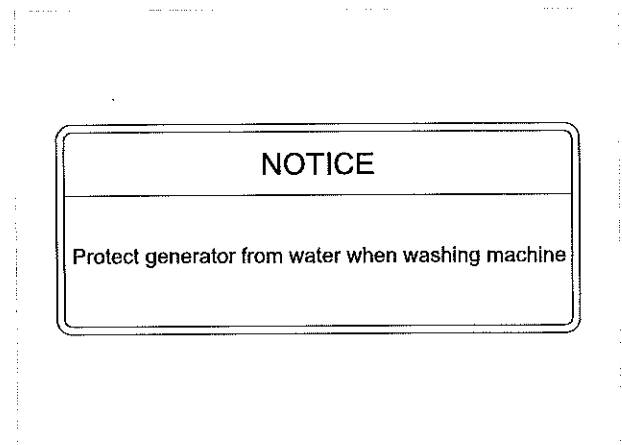

Fig.2-4

### 2.2.5.2 Safety symbols

Safety symbol uses an image to indicate a hazardous situation that is equivalent to a signal word. To make an operator or serviceman understand the type and level of a hazardous situation at any time, these safety signs are presented with images. The safety symbol indicates the type of dangerous situation when the operator or serviceman does some work on the equipment that the safety symbol is fixed to.



Fig.2-5

**Vibration warning**

- Stop vibration before the roller stops.

**NOTICE**

**It is forbidden to start vibration when the roller doesn't move, or the drums will be easily broken.**



Fig.2-6

**Read the manual & Noise**

- The instruction must be read prior to operation and maintenance, disassembly, assembly and transportation.
- When the roller is working, it will produce big noise. Take ear protection measures.

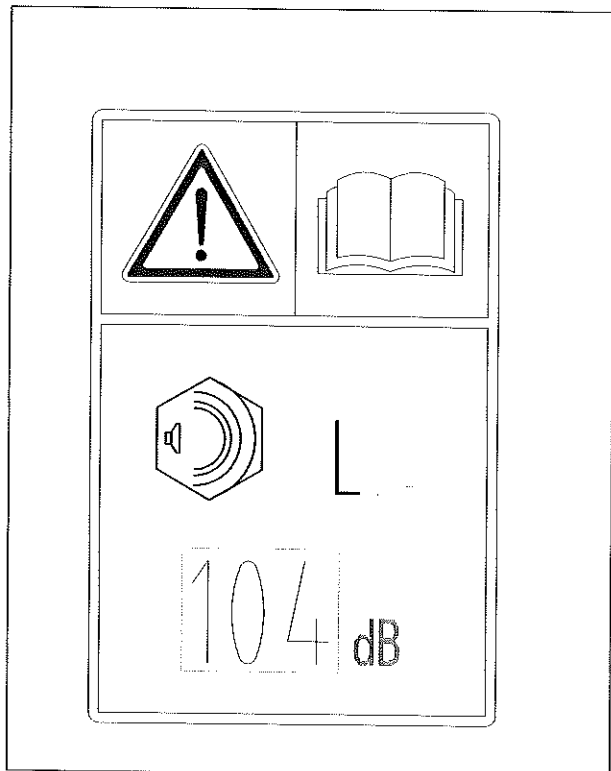

Fig.2-7

Water spraying notice

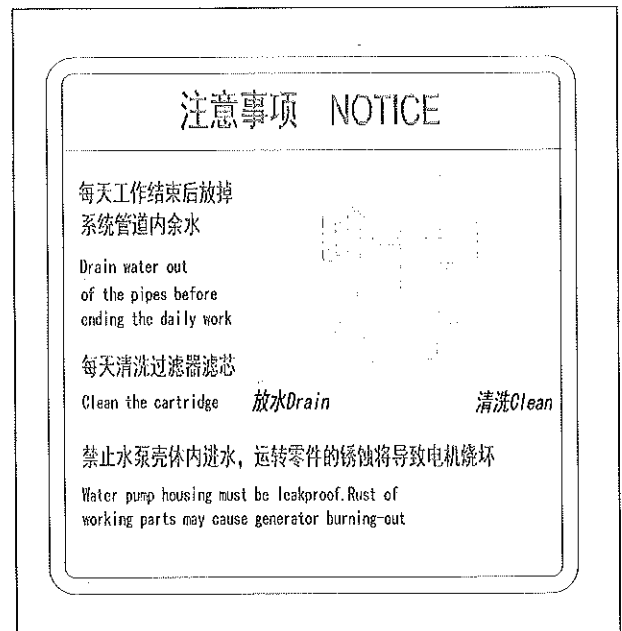

Fig.2-8

Lubrication points map

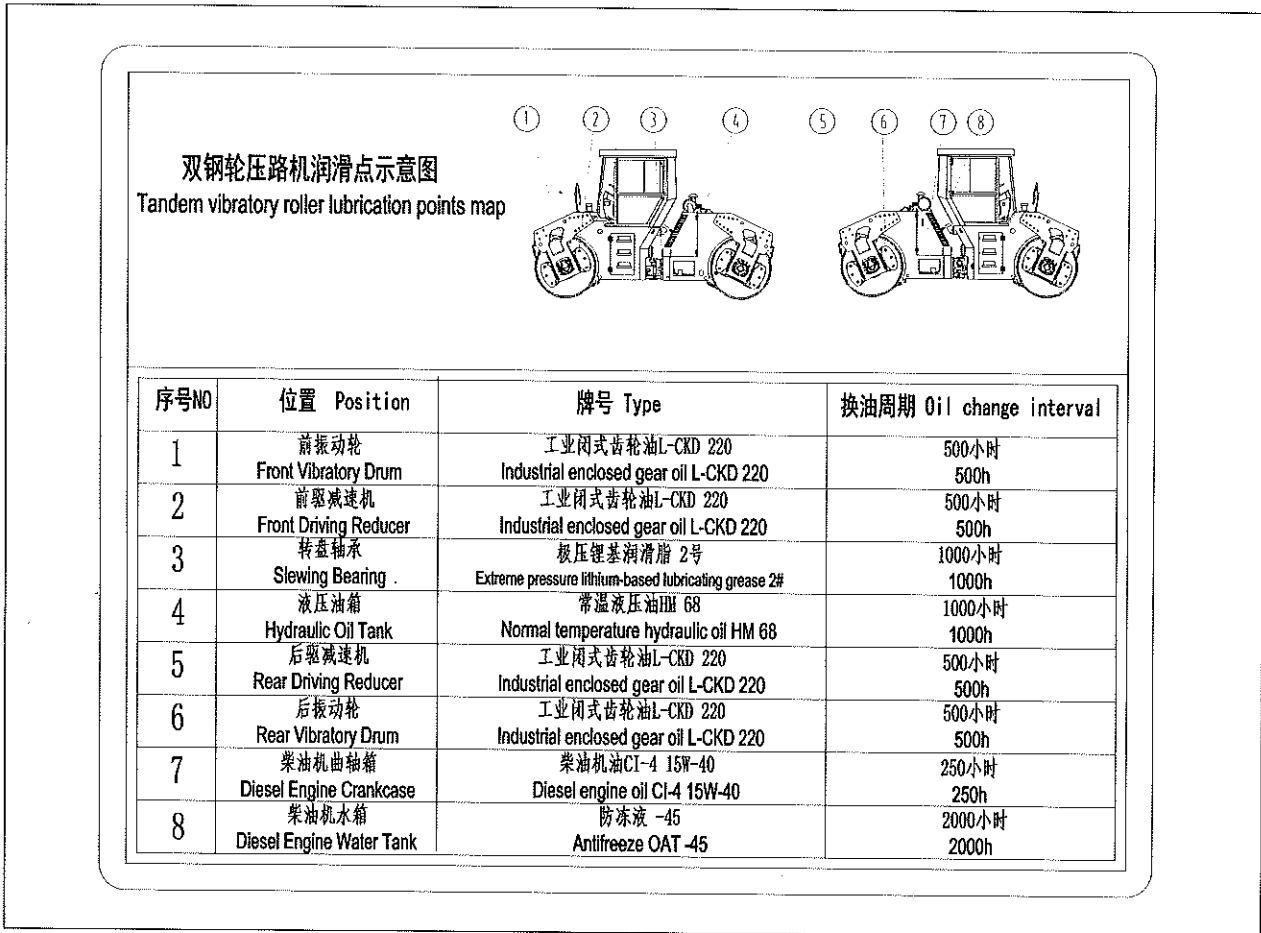

Fig.2-9

**Lift point**

Fig.2-10

**Notice for power switch**

- Before starting the roller, turn the switch to the "ON" position .
- If the roller is to be stored for a long time, turn off the power switch.

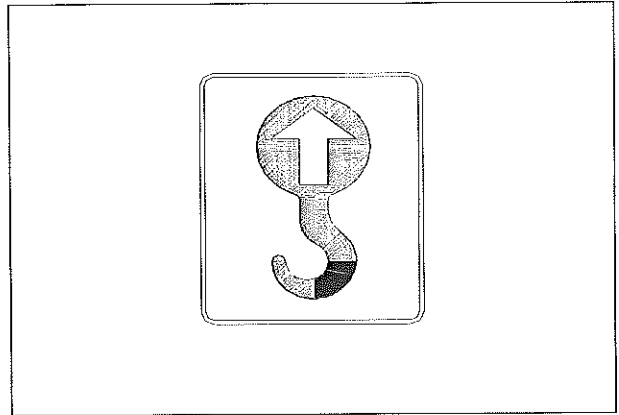
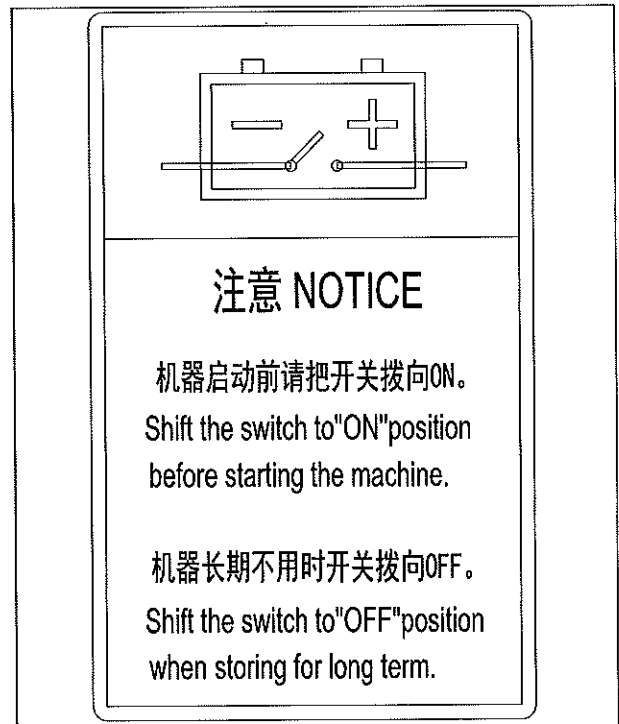

Fig.2-11

Lifting instruction

- Notes and proceedings for lifting.

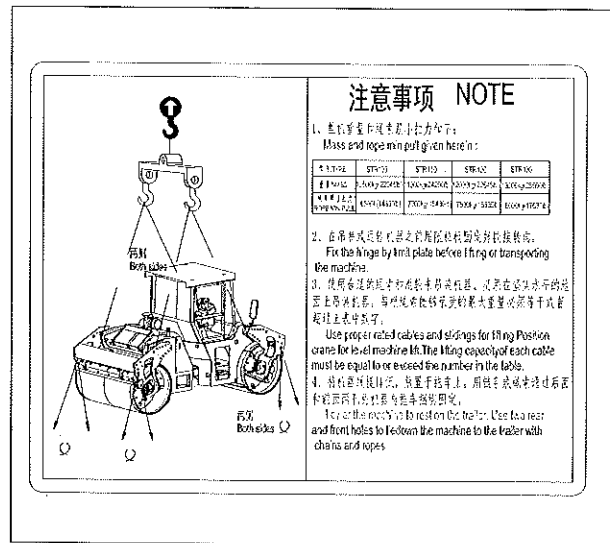

Fig.2-12

Caution for filter element



Fig.2-13

## Caution for lock pin of articulation frame

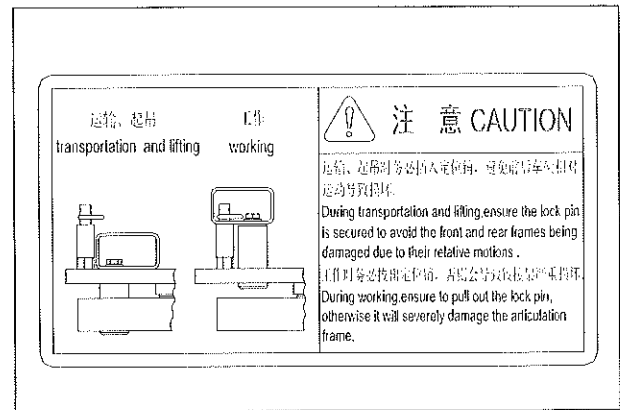

Fig.2-14

## Keep away

- Keep away from the center articulation frame when the roller is working, or you may be squeezed.

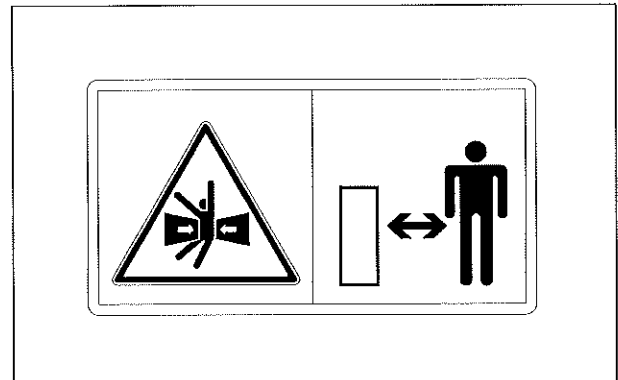

Fig.2-15

## 2.3 General Precautions

### 2.3.1 Safety rules

- Only trained personnel are allowed to operate and service the equipment.
- Never operate the roller that has fault.
- Never operate the roller in a hazardous situation.
- All safety rules, precautions and instructions must be followed when operating and servicing the equipment.
- Taking alcohol or drug could seriously impair one's ability in operating or repairing the equipment, and it is hazardous for you and other persons.
- When working with another operator or traffic signalman on the worksite, be sure to make all people understand all gestures to be used.

### 2.3.2 Abnormal case

In case of any abnormalities found during operation and maintenance, such as noise, odor, incorrect gauge display, smoke, or oil leakage, you are obligated to inform your boss and take necessary measures. Never operate the equipment before the faults are eliminated.

### 2.3.3 Safety devices

To protect yourself and others around you, your roller may be equipped with the following safety devices. See that each item is securely in place and in operating condition.

- Headlights, rear lights, turn lights
- Alert lights
- Rearview mirror
- Windshield wipers & washers
- Horn
- Safety decals



### 2.3.4 Protective measures for personal safety

Wear all work clothes and personal safety devices issued to you or called for your job conditions. You may need:

- Hard hat
- Hearing protection
- Reflective clothing
- Protective gloves
- Safety shoes

If necessary, wear respirator or filter mask.

Wear necessary equipment, and other safety equipment required by your employer, public and governmental administrations, laws and regulations. Never take a risk.

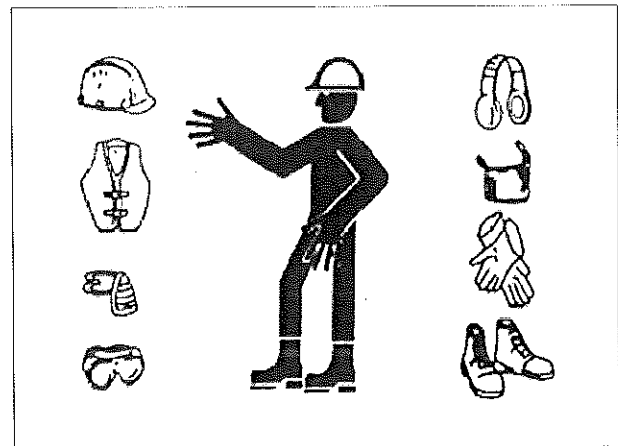

Fig.2-16

#### **⚠ WARNING**

- **Never wear loose fitting clothes and decorative ornaments, or you may easily get caught by the control lever or other protruding parts.**
- **Never let the long hair outside of the safety hat, or you may be entangled by rotating parts.**
- **If required, wear a hard hat, safety glasses, safety shoes, filter mask and gloves when operating or maintaining the equipment.**
- **Check all protective devices for proper functions prior to operation.**
- **Never listen to the radio or wear music earphones when operating, or it will easily attract your attention and cause accidents.**

Working around noise for a long time will cause damage or failure to hearing. When the roller with no cabin is used or the noise on the worksite is beyond 85 dB, please wear the audition protection device as earplugs. This would reduce the damages to human ears.

### 2.3.5 Precautions against emergency

Fully read the operation regulations and local driving laws, mastering the meaning of signal, gesture, symbol, and notification. Before driving the roller, it is forbidden to take excitant drink or drugs.

Find out the places placing fire extinguisher, emergency apparatus, and alarm telephone as well.

Avoid commonsense accidents. If accident occurs, try to adopt effective measures rapidly. First of all, it is most important to guarantee the personal safety, and then, consider reducing losses of goods and materials.

#### 2.3.5.1 Use the emergency stop switch correctly

### NOTICE

**The emergency stop switch should not be used as a brake switch normally. Or it will shorten the service life of the engine and other important parts.**

When an emergency incident happens, the operator can press down the emergency stop switch immediately to stop the roller. The switch is installed on the side box.

When the incident is eliminated, the operator can release the switch by rotating it clockwise and start the roller again.

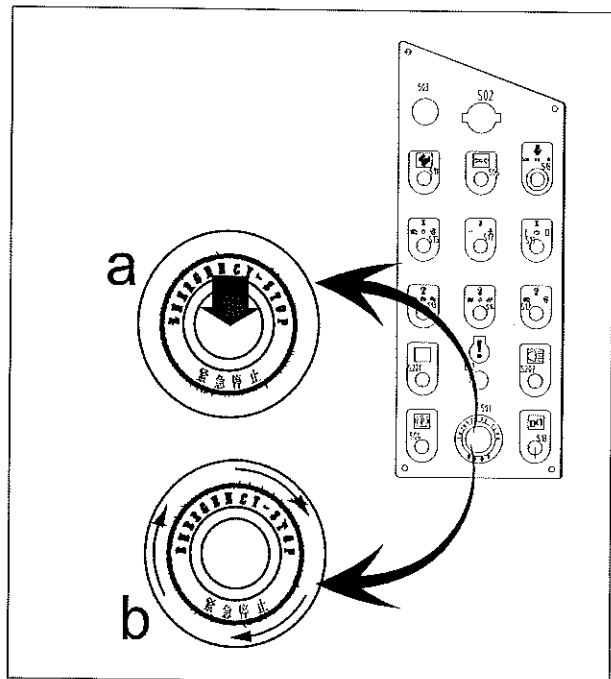

Fig.2-17

### 2.3.5.2 Evacuation in fire accident

Evacuate the equipment with the following methods in case of fire accident :

1. If time is sufficient, move the travel control lever to the "STOP" position, turn the parking brake switch (on the panel) to the "P" position.

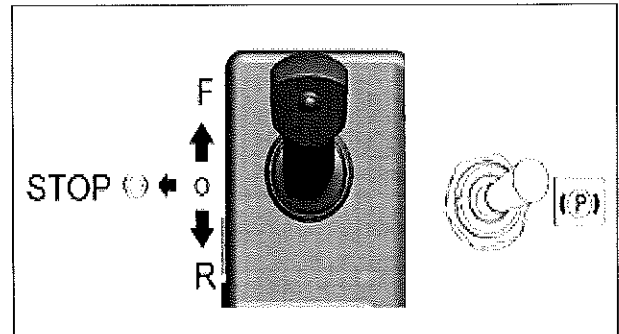

Fig.2-18

2. Turn the key switch to the "P/O" position. Remove the key.
2. Evacuate the equipment.
3. Use the fire extinguisher.

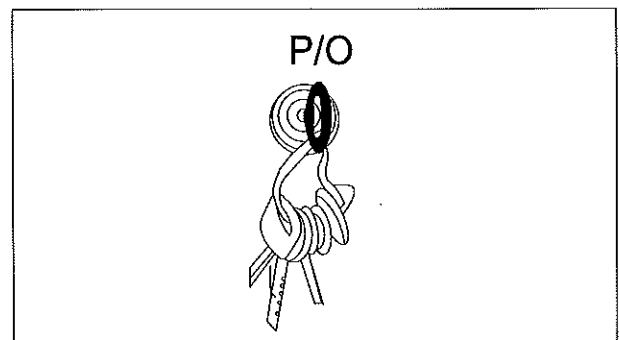

Fig.2-19

If time is insufficient, press down the emergency stop switch and evacuate the roller. Then use extinguishers or call fire fighters for help.



Fig.2-20

**2.3.5.3 Touching high-voltage lines**

When working near high-voltage lines, the operator should take extreme care. If the roller touches them during traveling, take measures as follows.

- Never leave the operator's seat.
- Warn other people to stay away from the roller.
- If possible, drive the roller away from the dangerous area.
- Cut off the power supply of the roller.

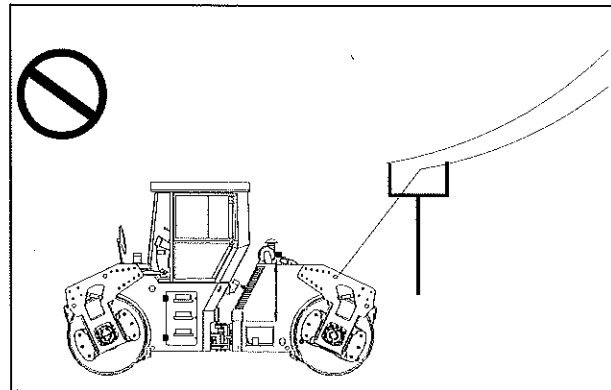

Fig.2-21

**2.3.5.4 Falling object protection**

If at a worksite the cabin has the danger of being hit or invaded by falling objects and scattered materials, protective cover must be used to protect operator according to the operating condition.

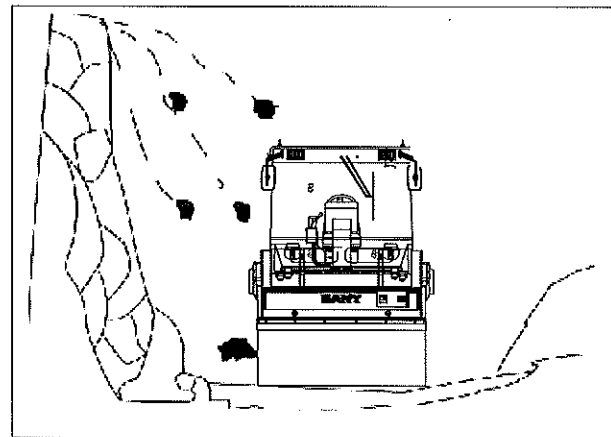

Fig.2-22

**2.4 Precautions During Operation**

**2.4.1 Safe starting**

**2.4.1.1 Safe mounting**

When you mount or dismount the equipment:

- Always face the roller and maintain a three-point contact (one hand and two feet or two hands and one foot).
- Never jump on/off the roller. Never mount a moving roller.
- Never use any control lever as a handrail.
- Remove the mud, oil dirt and water from pedal, handrails and shoes at any time.

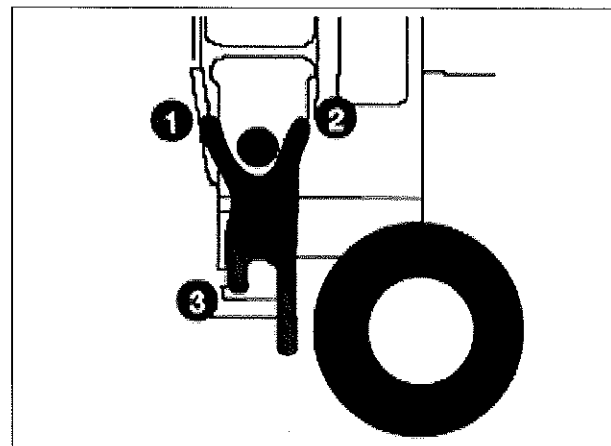

Fig.2-23

### 2.4.1.2 Seat adjusting

Uncomfortable seat position can easily lead to operator fatigue and operating mistake.

The seat position should be adjusted upon change of operator.

Leaning against the back of seat, operator shall be able to operate the control lever properly. Otherwise, the seat should be readjusted by moving it forward or reverse.



Fig.2-24

### 2.4.1.3 Seat belt

In case of tipping-over of the equipment, the operator could be injured or thrown out of the cabin, or be crushed by roller, causing serious injury or death. Before operating the roller, check the buckles for seat belt and fastening fittings carefully. In case of any damage or wear, the seat belt and other attachments should be replaced prior to operation. When the equipment is running, be seated in operator seat and fasten your seat belt to avoid accidents.

The seat belt should be replaced every three years regardless of its condition.

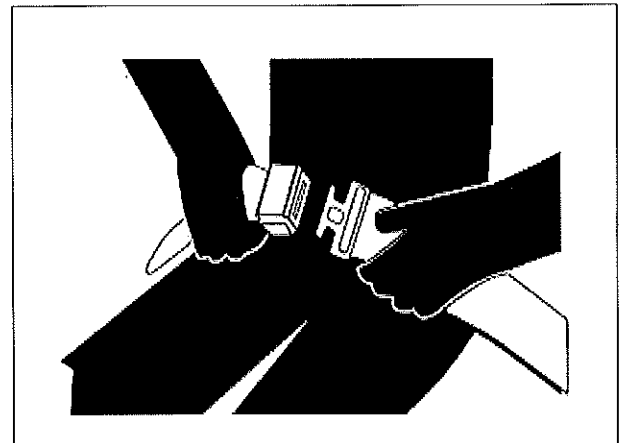

Fig.2-25

### 2.4.1.4 Before starting the engine

Before starting your daily work, the following items are to be observed prior to start of the engine.

- Check the levels of engine oil, hydraulic oil and coolant.
- Check if the lubrication points are lubricated properly.
- Check air filter for blocking.
- Check wires for damage.
- Set all control switches and levers to the "0" position or "NEUTRAL" position except the emergency stop switch.

- Adjust the seat to a position easy for operation; check seat belts and buckles for damage and wear.
- Adjust the rearview mirrors so as to see clearly from the driver's seat what is happening behind the roller.
- Clean the windows to ensure a good vision.
- Clean the headlights and work lights, and check them for regular functions.

Table 2-2 Diagram of Lubrication Points on tandem roller

序号NO	位置 Position	牌号 Type	换油周期 Oil change interval
1	前振动轮 Front Vibratory Drum	工业闭式齿轮油L-CKD 220 Industrial enclosed gear oil L-CKD 220	500小时 500h
2	前驱减速机 Front Driving Reducer	工业闭式齿轮油L-CKD 220 Industrial enclosed gear oil L-CKD 220	500小时 500h
3	转套轴承 Slewing Bearing	极压锂基润滑脂 2号 Extreme pressure lithium-based lubricating grease 2#	1000小时 1000h
4	液压油箱 Hydraulic Oil Tank	常温液压油HM 68 Normal temperature hydraulic oil HM 68	1000小时 1000h
5	后驱减速机 Rear Driving Reducer	工业闭式齿轮油L-CKD 220 Industrial enclosed gear oil L-CKD 220	500小时 500h
6	后振动轮 Rear Vibratory Drum	工业闭式齿轮油L-CKD 220 Industrial enclosed gear oil L-CKD 220	500小时 500h
7	柴油机曲轴箱 Diesel Engine Crankcase	柴油机油CI-4 15W-40 Diesel engine oil CI-4 15W-40	250小时 250h
8	柴油机水箱 Diesel Engine Water Tank	防冻液 -45 Antifreeze OAT -45	2000小时 2000h

### 2.4.1.5 Engine starting

Before starting, be sure there is nobody under or around the roller. Sound the horn for warning.

- Start or operate the roller in a seated position.

- No one is allowed to stay on the roller except the operator.
- Never start the engine if you think there could be a short circuit, which is dangerous and can cause damage to the roller.

To understand proper starting steps of the roller, see: **Section 4.4 "Engine Starting" on page 4-14.**

In cold weather, sufficient warm-up operation is necessary. Incomplete warm-up may result in slow reaction and accidents.

Before starting, check the battery to see if its electrolyte is frozen or leaks. In case of frozen electrolyte, never charge the battery.

The use of jump-start must be carried out according to the instructions in operation section. **See:Section 4.4.2 "Jump-start" on page 4-15.** Improper operation can lead to battery explosion or roller out of control, hence personal injury and death.

## NOTICE

**Never use the jump-start personally. Or it may lead to serious accident. Contact SANY distributor when necessary.**

### 2.4.1.6 After starting the engine

## WARNING

**Prior to operation, be sure you can properly control the speed, direction, braking, turning and working mode of the roller. Roller out of control can cause serious injury or death.**

Observe the pressure gauges, instrument and warning lights to ensure they are properly functioning, with all readings within specific ranges.

## 2.4.2 Safe operation

### 2.4.2.1 Surveying the worksite in advance

#### **WARNING**

**The roller may roll over when working at the ditch edge or on road shoulder, which may result in serious accidents.**

Check the worksite and road conditions in advance to prevent the roller from overturning, or even the ground, material stockpile or bank from collapse. Reinforce the ground, ditch edge and road shoulder according to requirements and keep a certain distance between the roller and the ditch edge or road shoulder. Formulate a working plan and use the roller applicable to the work and construction site.

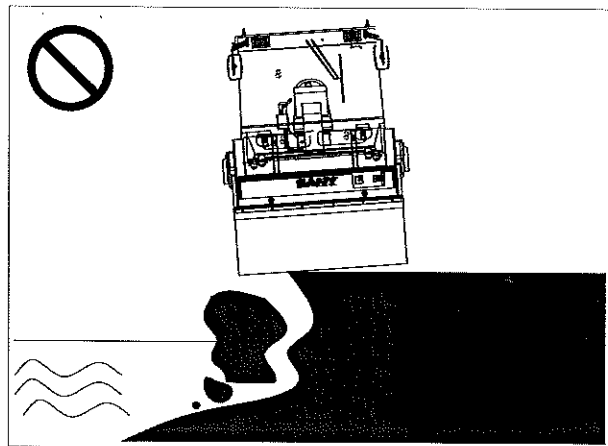

Fig.2-26

For the multi-roller operation, the united signals are required to be applied. Appoint a signalman to organize the operation, and make sure all workers obey the guide of the signalman. A signalman is also on demand when working on a slope or on a road shoulder.

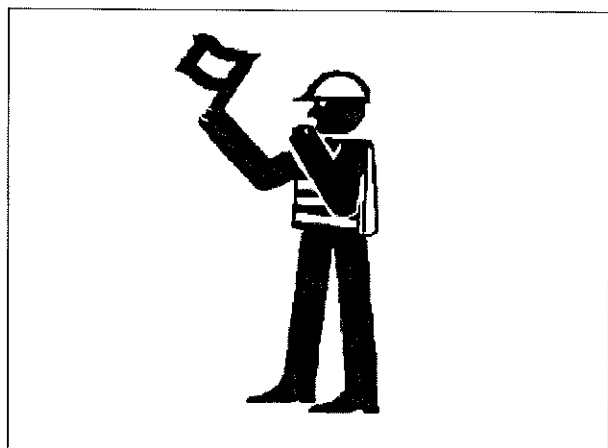

Fig.2-27

Keep especially alert when working on an icy road, since the rise of the ambient temperature will make the foundation soft and slippery.



**NOTICE**

**Never run the roller on a slope or a muddy road beyond its allowable gradeability. Or it will affect the service of the engine.**

See: Section 7.2 "Specifications of the Equipment" on page 7-2 for the roller's gradeability.

Don't operate the roller on the ground not solid enough or with holes. Never start up and operate the roller in a combustible and explosive environment. For example, avoid operating it in a narrow or unventilated space. Keep good ventilation in any conditions.

Make sure when the vibratory roller is working, there isn't any vulnerable building and equipment around. The damage caused by the vibratory roller can affect certain distance range.

If the rolling materials will induce dust, install ventilation devices, water the pavement or wear a gauze mask.

**2.4.2.2 Before operation**

Test the roller before operation.

- When conducting inspection, move the equipment to a spacious area without barriers and operate slowly. Any other person is not allowed to approach the equipment.
- Check the roller for abnormality such as abnormal noise, vibration, smoke, odor or gauge reading and leakage.

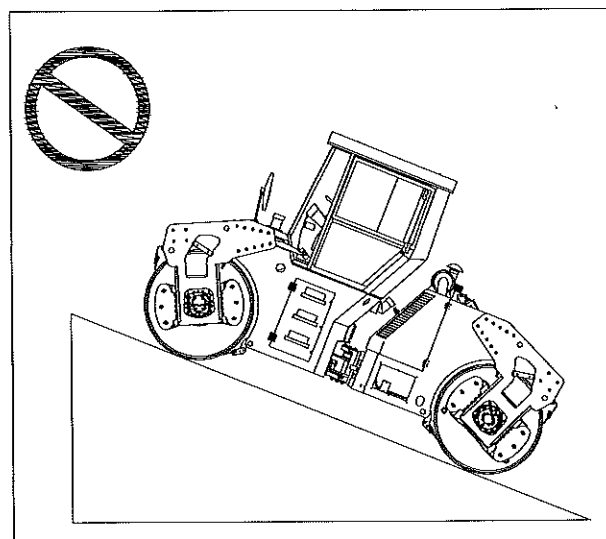

Fig.2-28

- When the travel control lever is at the "0" position, turn the throttle control switch to "ECO" or "HI", then operate the travel control lever to drive the roller at working speed.

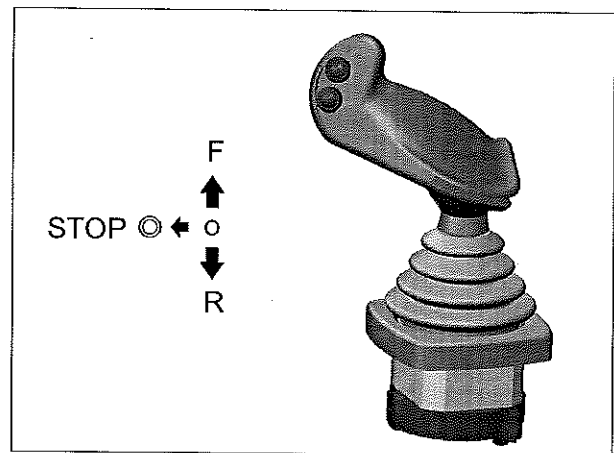

Fig.2-29

- Fully understand the operations under different working modes of the roller.
- In case of any abnormality, stop operation and take corrective measures immediately.

## NOTICE

**When hearing abnormal noise, first check the noise to see if it comes from inside. If it really comes from inside, shut down the roller immediately, or it may lead to further fault.**

### 2.4.2.3 Safe traveling

When driving the roller, the operator should observe the following provisions:

- It's forbidden to carry people on the roller except the operator.
- It's forbidden to mount or jump off a moving roller.
- Operate the equipment only on the operator's seat. Keep the seat belt fastened and the cabin door closed during working.
- Do not adjust operator's seat when driving.

- Sound the horn to warn persons around, and make sure there's no person or obstacle nearby.

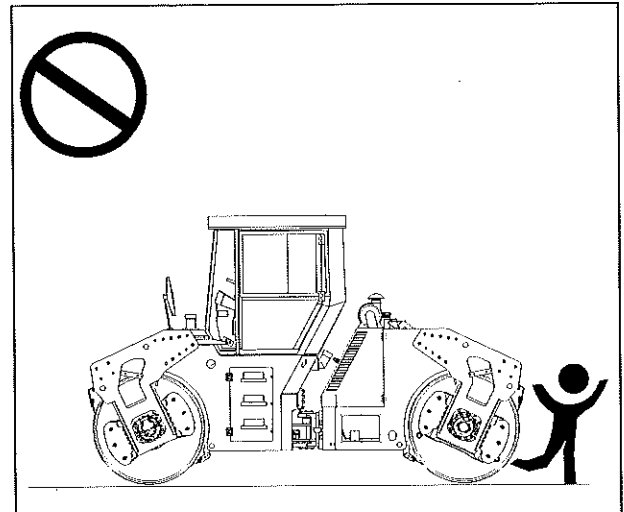

Fig.2-30

- The driving speed should match the working condition. When the road is flat and straight, high speed is allowed; when the road is getting worse, the low speed is demanded. **See: Section 7.2 "Specifications of the Equipment" on page 7-2** for more details.

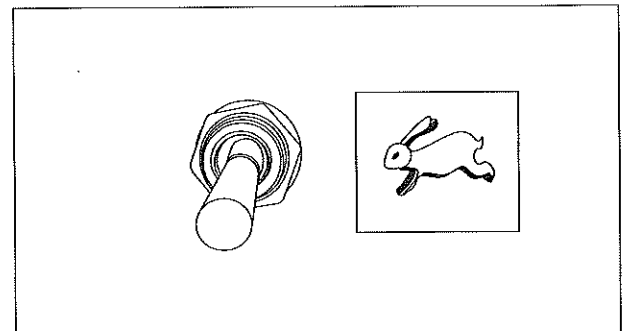

Fig.2-31

- Only when the roller is stopped can the operator change the gear.
- When traveling on a slope, make sure the degree of the slope is not beyond the roller's allowable gradeability. **See: Section 7.2 "Specifications of the Equipment" on page 7-2** for more details.

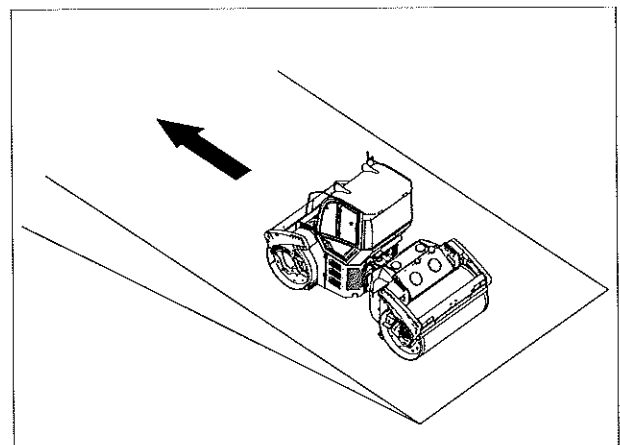

Fig.2-32

- When driving on a slope, it's only allowed to drive upward or downward in a straight line at a low speed. Traveling across a slope is prohibited.

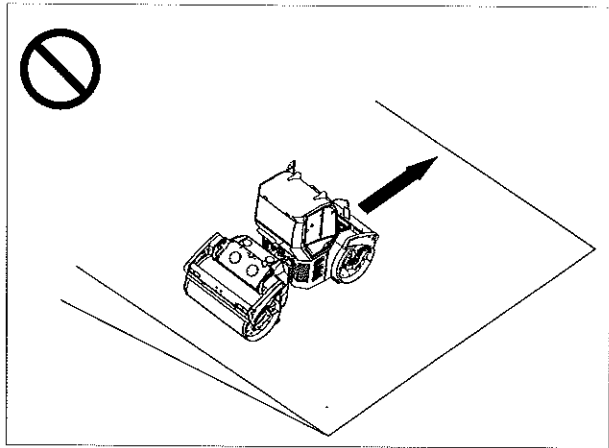

Fig.2-33

- When danger occurs, press down the emergency stop switch immediately. Do not use the emergency stop switch as the normal brake.
- Restart the equipment only after the danger is eliminated.

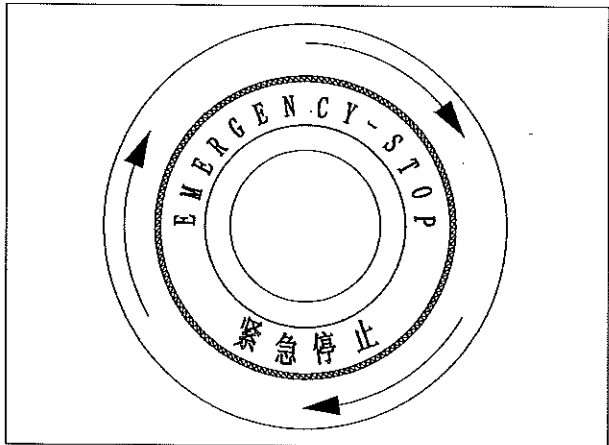

Fig.2-34

- In poor visibility conditions, turn on the work lights for clearer vision.

#### 2.4.2.4 Safe turning

When making turning, the operator should observe the following provisions:

- When changing direction, make sure there is no person near the center articulation frame.

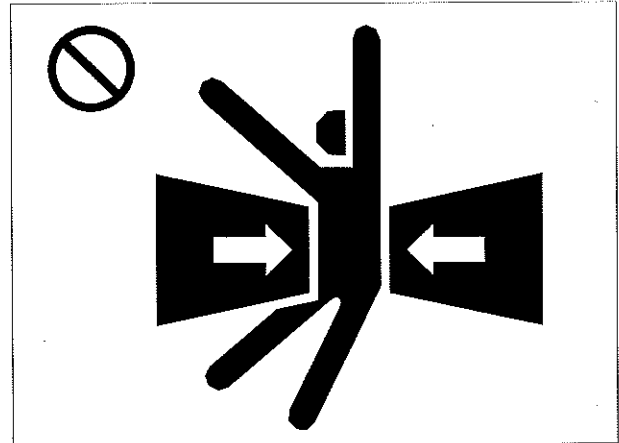

Fig.2-35

- Only when the roller is at the low speed can the operator change the direction.
- Don't make any abrupt turning.

#### 2.4.2.5 Safe vibrating

When the roller starts vibrating, the operator should observe the following provisions:

- Never start vibration without traveling.
- Never start vibration on hard ground.
- Take the nearby buildings and underground facilities into consideration before vibration.
- Don't start vibration on sloppy road, for it will increase the danger of side sliding.
- When compacting the road edges adjacent to pavement, ensure that more than 2/3 part of the drum is on the road compacted previously.

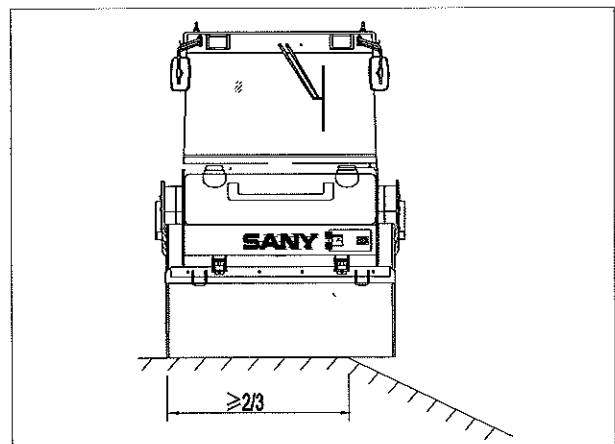

Fig.2-36

- Only when the roller stops vibrating can the operator change vibration frequency or working mode.

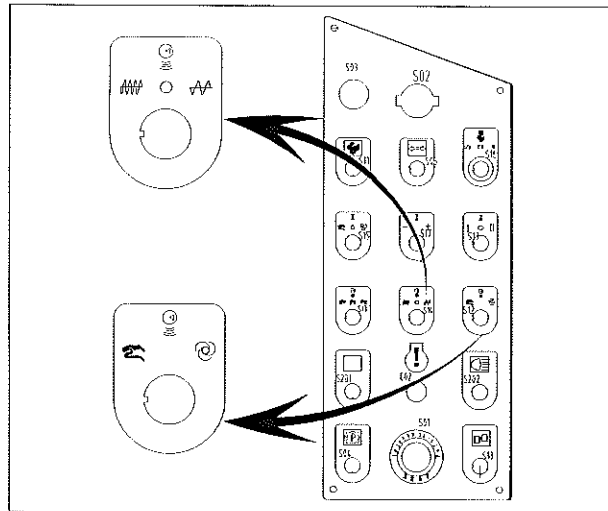

Fig.2-37

### 2.4.3 Safe parking

#### 2.4.3.1 Requirements for parking area

When parking the roller, the operator should observe the following provisions:

- Try to park the roller on flat and solid ground.
- Try to park the roller indoors, avoiding insolation or drenching.
- If it is required to park on a slope, make sure that the gradient of the slope is not beyond the roller's gradeability. **See: Section 7.2 "Specifications of the Equipment" on page 7-2** for more details.

#### 2.4.3.2 Parking rules

- Follow the parking steps to park the roller. **See : Section 4.9.2 "Parking brake" on page 4-28.**
- Wedge the drum and rear tires with objects to avoid sliding if the roller is to be parked on a slope.

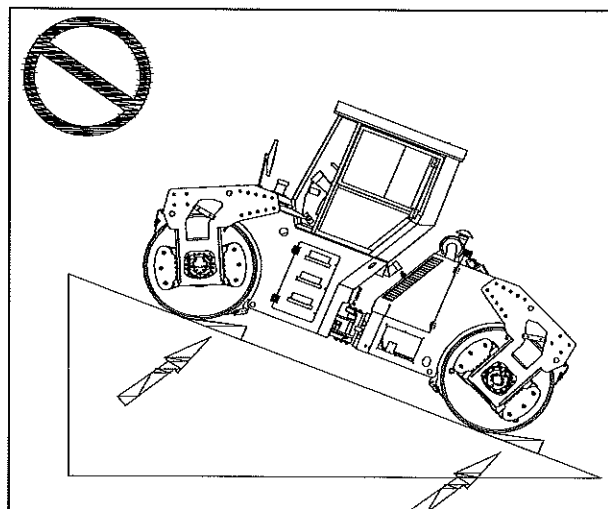

Fig.2-38

## 2.5 Maintenance Precautions

### 2.5.1 Basic rules

- It is forbidden to use a damaged roller or the one with potential troubles.
- Only the qualified and authorized maintenance staff can maintain the equipment.
- Observe the maintenance regulations, including spare parts replacement.

### 2.5.2 Lockout/Tagout procedures

Only authorized employees performing repairs on the roller shall perform Lockout/Tagout in accordance with the procedure listed below.

If the employee performing repairs to the roller is issued a lock and key, the employee shall not share the lock or key with other employees until all repair procedures are complete and the machine is ready to put back into service.

The following steps shall be performed in the sequence listed when the roller is to be locked out and tagged-out for service or repair.

#### Locking out of service

- Notify all employees who may be potentially affected by the repair or maintenance on the roller.
- Secure the machine in a safe position. Set the parking brake switch to the "P" position (See Fig.2-21 on page 2-16).
- Identify, remove or disconnect all power or energy sources and be sure to install a Lockout/ Tagout device on them.
- Be sure all employees involved in the repairs have installed the lock on the power source before performing any repairs. Once an employee has completed the repair procedure, they must remove the lock and not access the roller in any manor.

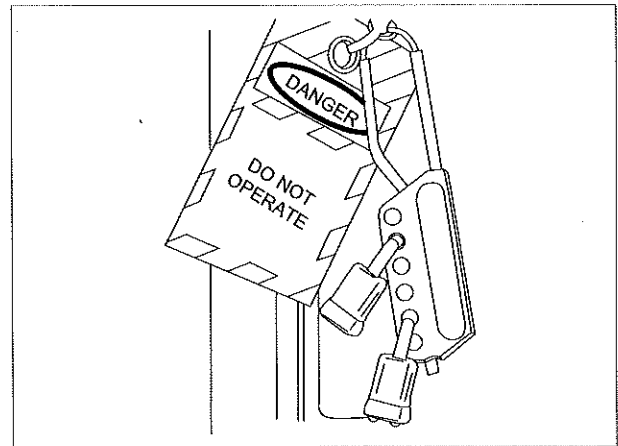

Fig.2-39

### Returning to service

- The authorized person who performed the lockout/tagout procedure shall check the area around the roller to ensure that no one is exposed to any hazard before start-up.
- The authorized person who performed the lockout/ tagout shall ensure that all guards have been reinstalled to their proper place, all tools and equipment have been removed and all locks are removed.
- The authorized person who performed the lockout/tagout shall verify that all controls are at the "NEUTRAL" or "0" position and all personnel are aware of the time the roller will be back in service.
- Remove the Lockout/Tagout mechanisms and all tags and re-energize the roller for return to service.

### 2.5.3 Working area preparation

#### CAUTION

**If a clean, tidy working area cannot be guaranteed, there would be danger of tipping, thus resulting in personal injury.**

- For maintenance work, select a clean flat area with plenty of space, ample sunlight and good ventilation.
- Clean the working area by removing fuel, lubricant and water, and covering slippery ground with sand or other absorptive materials.



### 2.5.4 Washing the equipment

When washing the equipment, always do as follows.

- Wear non-slip shoes to prevent yourself from slipping on the wet surface.
- When using high-pressure steam to wash the equipment, always wear protective clothing. This will protect you from being hit by high-pressure water, and cutting your skin or getting mud or dust into your eyes.
- Never spray water directly onto the electrical system (sensors, connectors). If water gets into the electrical system, there is danger that it will cause defective operation and malfunction.

### 2.5.5 Self-preparation

Only approved personnel can maintain or repair the equipment. An observer could be assigned if necessary.

Wear protective clothing and shoes necessary for the job.

- Wear rubber apron and rubber gloves when handling corrosive materials. Wear heavy gloves when handling wooden materials, wire ropes or sharp-edged metals.
- Wear a face shield when removing spring or elastic parts, or adding acid to battery.
- Wear safety hat and goggles when you weld or cut with a torch.
- Never carry out grinding, flame cutting or welding without aspirator and ventilation equipment.

### 2.5.6 Proper tool

#### **⚠ WARNING**

**Use proper tools and use them correctly during operation or maintenance. Using damaged, inferior, defective or disposable tools or using tools wrongly could cause accidents.**

Use proper tools and use them correctly as follows:

- Use boosters like various spanners or plus drive to disassemble connecting parts. See Fig.2-42. For the tightening torque of bolts, see Table 5-1 on page 5-6 and Table 5-2 and Table 5-3 on page 5-7.
- Use pressure gauges to check fluid pressure values and air pressure values. See Fig.2-43. The correct uses of V-belt tension gauge have been described, see: section 5.4.3.19 "Engine belt" on page 5-21.
- Use gas cutting or gas welding carefully to avoid explosion.
- Use jacks or iron pillars to support the machine or accessories safely. See Fig. 2-44.

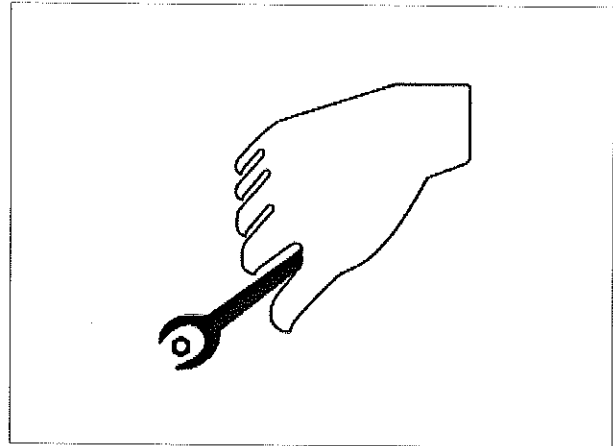

Fig.2-40

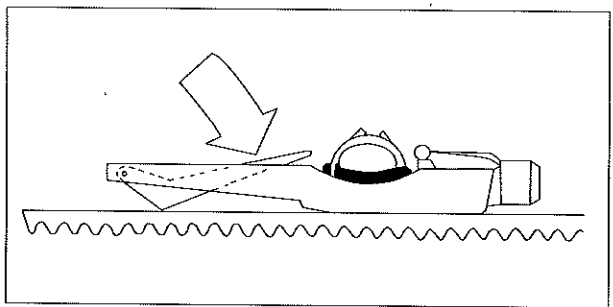

Fig.2-41

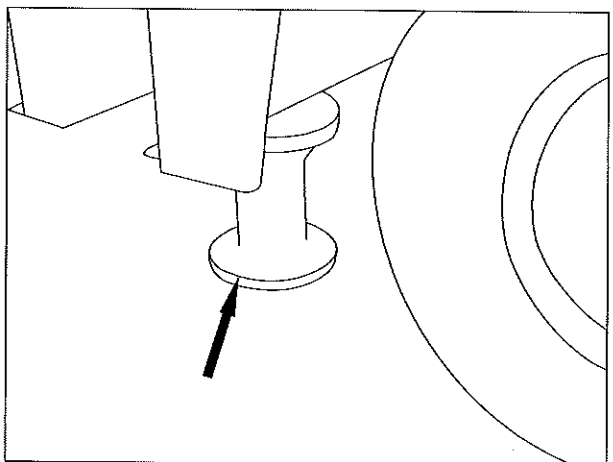

Fig.2-42

### 2.5.7 Maintenance with engine running

In most cases, the engine should be shut down prior to the maintenance work. If maintenance has to be done on a running engine, there should be at least two people handling the maintenance according the following rules.

- One person should always be seated in operator's seat and ready to shut down the engine at any time. All personnel must keep in touch.

- Place the travel control lever to the "STOP" position in order to prevent movement of work equipment. If it must be used, send signal to others and warn them to move quickly to a safe area.
- Pay special attention to rotating parts like fan and conveyor belt, people may get caught by them when staying close.

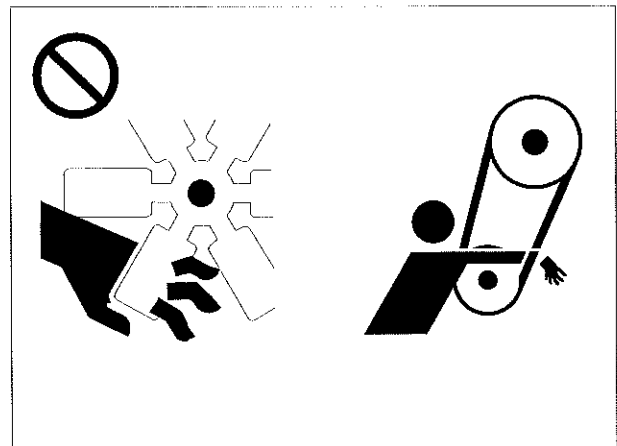

Fig.2-43

- Never leave or insert any tool or other objects in fan or conveyor belt, which may cause the parts to break or fly.

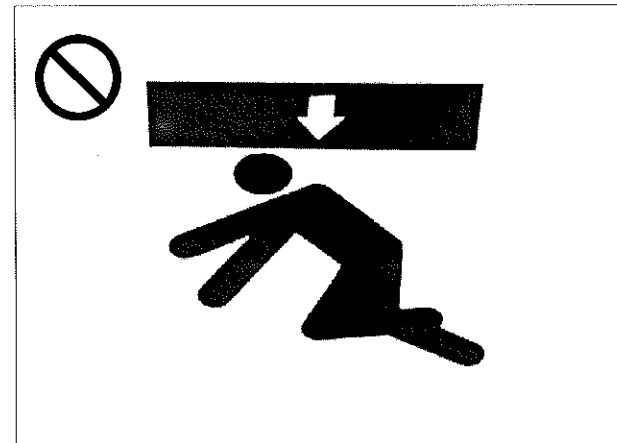

Fig.2-44

### 2.5.8 Working under the roller

- No maintenance shall be carried out before the roller is well supported. Ensure that the the roller and its accessories are safely, stably and reliably supported.
- Never use bricks or wood blocks to support the roller.
- Never use the device which may slide to support the roller.
- Never use slag bricks, hollow tires or shelves to support the roller, as they may collapse under continuous load.
- If the roller or the accessories must be raised up for maintenance, the roller or its working device shall be supported with multiple jacks or iron columns.

### 2.5.9 Working in noisy environment

If noise of the roller is too big, it will cause permanent or temporary hearing disability.

When maintaining the engine, wear ear covers or ear plugs if you have to work in noise for a long time.



Fig.2-45

### 2.5.10 Removing paint before welding or heating

- Poisonous gas will be produced by paint heating during the fusion welding, soldering or gas torch application.
- Remove the paint outdoors or in the places with good ventilation.
- If using sand paper or grinding wheels to remove the paint, wear a qualified respirator to protect yourself from inhaling dust.
- If the solvent or the rust remover is used, the paint and solvent shall be handled in a proper way. Wait for at least 15 minutes for volatilization of volatile gas before welding or heating.

### 2.5.11 Correct welding

The correct welding procedures must be used to protect the electronic control and the bearings from being damaged. When carrying out welding on the roller equipped with the electronic control, comply with the following procedures:

- Stop the engine, and remove the key after turning the key switch to the "O" position.
- Remove the negative cable of the battery. Never use the grounding point of electric spare part (including electric control modules or sensors) as the grounding point of the electric welder.

- Clip the components to be welded with the grounding wire clamp of the welder. Set the clamp near the welding point to make sure the current flow is away from the key components, such as transmission system bearing, hydraulic parts, electrical parts, and so on.
- Protect the wire harness from contacting scraps and splashes produced during the welding.
- Weld the materials together by following standard welding process.

### **⚠ WARNING**

If welding or other operations inducing abundant heat or open fire are required, oil in the oil tank should be drained out completely, and dry it as well. Or it may catch fire during welding, and endanger the worker's safety.

### **⚠ CAUTION**

Welding near the plastic and rubber materials is forbidden, such as, near the scraper made by polyurethane, for toxic fume will be produced and it will do harm to the worker's health.

#### **2.5.12 No heating beside hydraulic pipeline**

- Heating beside the pressure pipe will produce combustible spray, which may cause the operator and the bystanders to be seriously burned.
- Fusion welding, soldering or usage of gas torch beside hydraulic pipeline or other combustible materials are not allowed.
- When the heat goes beyond the direct combustion area, the hydraulic pipeline

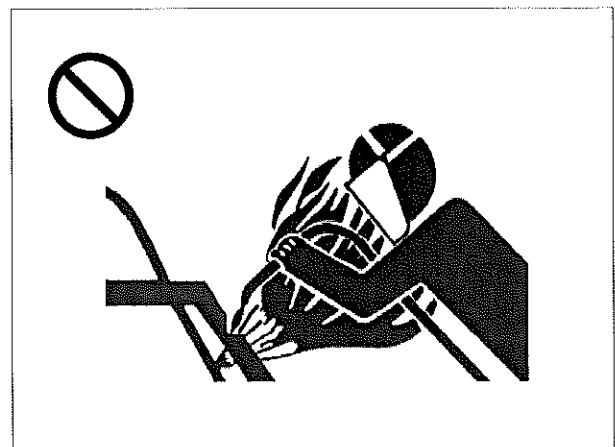

Fig.2-46

may be cut off at any time. Establish a temporary fire protective sleeve when performing fusion welding or soldering to protect hoses or other materials.

### **2.5.13 No heating the pipes with combustible liquid**

- Welding or gas cutting of the pipeline or hose with combustible liquid is not allowed.
- Remove the combustible liquid completely with noncombustible solvent before welding or gas cutting the pipeline.

### **2.5.14 Correctly operating the hydraulic system**

- Periodical maintenance to the hydraulic system is very important. The hydraulic system of the roller works under high oil pressure, small damages and cracks at the rubber hose and the adaptor will cause disastrous results. As the hydraulic tube is made up of rubber, cracks will appear after a certain period; in any circumstances, if the service life of the rubber tube is uncertain, replace it with a new rubber hose provided by SANY.
- Never fill oil directly to the hydraulic oil tank, otherwise the cleanness of the hydraulic system may be influenced, and the valid life of the equipment may be reduced! When filling the hydraulic oil tank, use a filtering equipment with a filtration precision of 10 $\mu$ m.
- Make sure the pressure control valve is set correctly. High pressure will result in hydraulic line leakage. Low pressure will result in difficult operation of the roller.
- Adjustment of the system pressure, main oil pump as well as assembly, disassembly or replacement of the valve block only can be done under the instruction of a hydraulic

engineer or an after-sales engineer. Unauthorized persons are forbidden to adjust by themselves.

- As the rubber hose is an easily-corrosive product, do not store it for a long time.
- When dismantling the oil pipes, close the port and keep the hydraulic pipeline clean.
- Check the filter element frequently.
- The hydraulic parts are essential to the system. Use the original hydraulic parts produced by our company.

### 2.5.15 Being aware of high-pressure liquid

- The hydraulic system may still have pressure even when operation has been stopped; such liquid as diesel oil and hydraulic oil spurting out under pressure may penetrate the skin or eyes resulting in serious injury, blindness or even death.



Fig.2-47

- Release pressure before disassembling the hydraulic parts or other pipelines to avoid such dangers caused by high-pressure liquid.
- Fasten all joints before pressurizing.
- Wear protective goggles, masks and gloves when checking the hydraulic system. Use cardboard when checking for leaks.

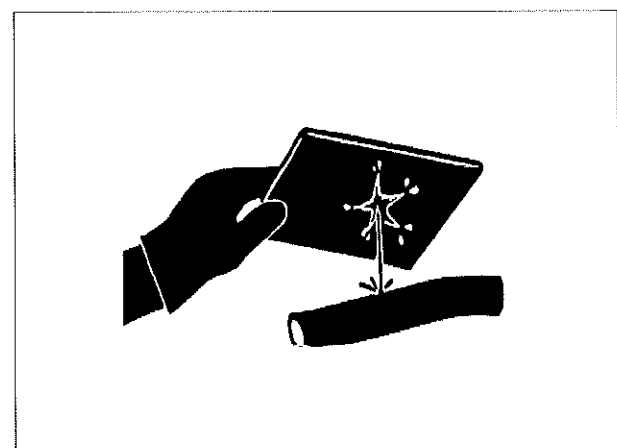

Fig.2-48

- Protect your hands and body from contacting with high-pressure liquid. If the hydraulic liquid spatters onto the skin or into the eyes, seek medical care immediately.
- If any liquid jets into skin, remove it within several hours by surgical treatment from a professional surgeon.

### 2.5.16 Regularly replacing the rubber hoses

- Rubber hoses with combustible liquid may break under pressure due to aging and excessive abrasion. The ageing and abrasion of the rubber hoses are difficult to be judged only through check. Regularly replace the rubber hose.

### 2.5.17 Avoiding scald by high-temperature liquid

- After operation, the coolant in the engine becomes hot with pressure, and the water pipes of the engine and the radiator are full of hot water and vapor. Avoid scald by possibly jetting hot water. Hot water or vapor overflowed will result in serious scald.
- Before removing the radiator cover, stop the engine and let the system cool down. The radiator cover could only be removed after the cooling fluid has cooled down.
- The hydraulic oil tank is pressurized after operation. Release the pressure before removing the cover.
- The engine, gear and hydraulic oil will turns hot during operation; meanwhile, the engine, hose, pipeline and other parts will turn hot. Check or maintain the equipment after the oil and parts cool down.



Fig.2-49



### 2.5.18 Preventing battery from explosion

- The battery contains toxic and corrosive sulfuric acid. If the battery explodes, the electrolyte may spatter into eyes, which may cause blindness. Always wear goggles before checking the the electrolyte.

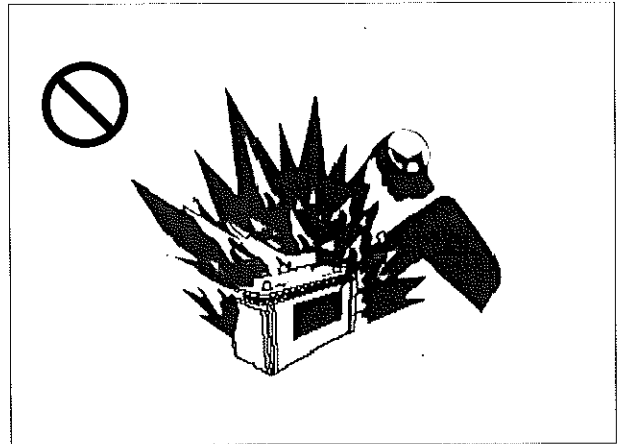

Fig.2-50

- Wear gloves when operating on the battery. Battery electrolyte is strongly corrosive. If your clothing and skin are contaminated by electrolyte, flush immediately with large amount of water and then seek medical treatment immediately.
- Don't charge a frozen battery, which may lead to explosion. Warm the battery to 16°C at first.
- The gas produced by the battery is easily explosive; if the battery is very close to open fire or sparkle, explosion will possibly occur.
- Take extreme care when installing and replacing battery so as to avoid short circuit. When removing the connection of the battery, first cut off the negative terminal.
- When charging the battery, first disconnect the power supply of the charger before connecting the charger with the cable of the battery.

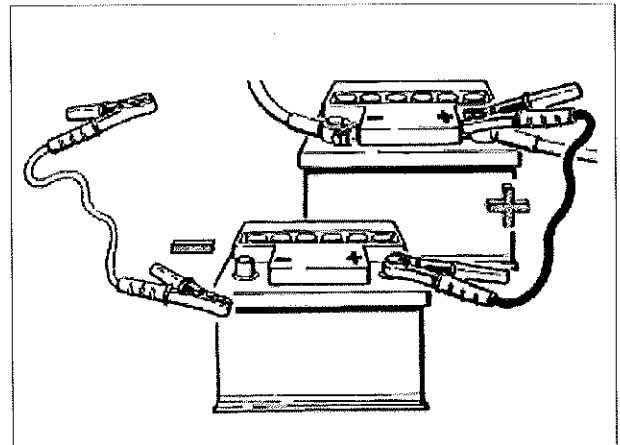

Fig.2-51

**2.5.19 Preventing components from flying out**

Since the components may fly out, keep your body and face away from the valve body to avoid injury.

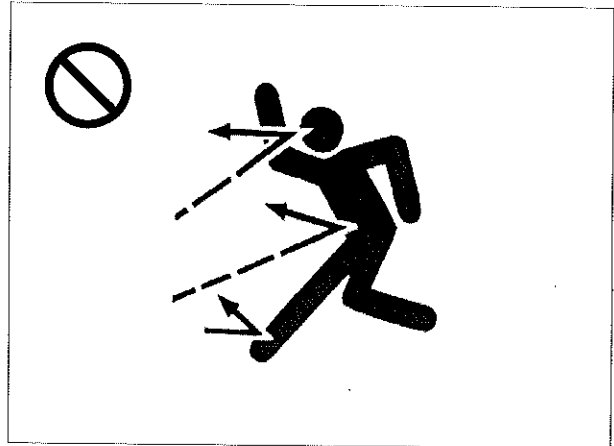

Fig.2-52

**2.5.20 Safe storage of parts**

- The stored parts may fall off, resulting in severe injury or death.
- Store the parts and instruments properly to prevent them from falling. Keep children and other persons away from the storage area.



Fig.2-53

**2.5.21 Safe treatment of liquid**

- No smoking when refilling the fuel tank.



Fig.2-54

- Stop the engine before refilling.
- Refill outdoors.
- Store the combustible liquid away from the places where fire easily bursts out.
- Don't burn or pierce the pressure container.
- Don't store the oily cloth for it is easily ignited or easily burns spontaneously.

### 2.5.22 Safe treatment of chemicals

- Contacting hazardous chemicals directly will cause serious personal injury. The chemicals used for this equipment include lubricant, coolant, paint and adhesive.
- Check and understand the hazardous character of the chemical before using it. Use recommended instrument in accordance with the regulations.

### 2.5.23 Proper disposal of wastes

- The improper disposal of wastes will endanger the environment and ecology. The toxic substances hidden in the equipment of SANY involve oil, fuel, coolant, brake fluid, filter and battery and so on.
- Use a leak-proof container to drain fluid. Never use the container used for food or drink.
- Never pour waste fluid on the ground, into the sewer or any water sources.
- Consult the local environmental protection or recycle center or your appointed distributor for correct recycle and disposal methods of wastes.

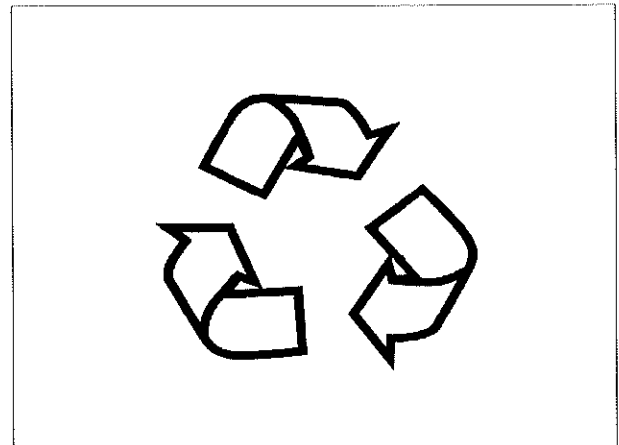

Fig.2-55

## 2.6 Safe Transportation

### 2.6.1 Load/Unload the roller

When loading or unloading the roller from the truck or platform trailer, the roller may overturn.

Provide a truck or platform trailer with suitable size and load to transport the roller.

Precautions during the loading/unloading of the roller.

- Choose the solid and level ground.
- Adopt a platform or incline.
- Assign a signalman to guide the loading/unloading of the roller.
- Since it is quite dangerous to steer on the incline, avoid steering when driving upward or downward on the incline. If necessary, drive the roller back to the ground and correct the direction before driving on the incline.
- Carefully drive over the convex adaptor between the incline top and the flat plate.
- For more details on how to load and unload the roller, see: **Section 4.15.2 "Using a slope"** on page 4-38.

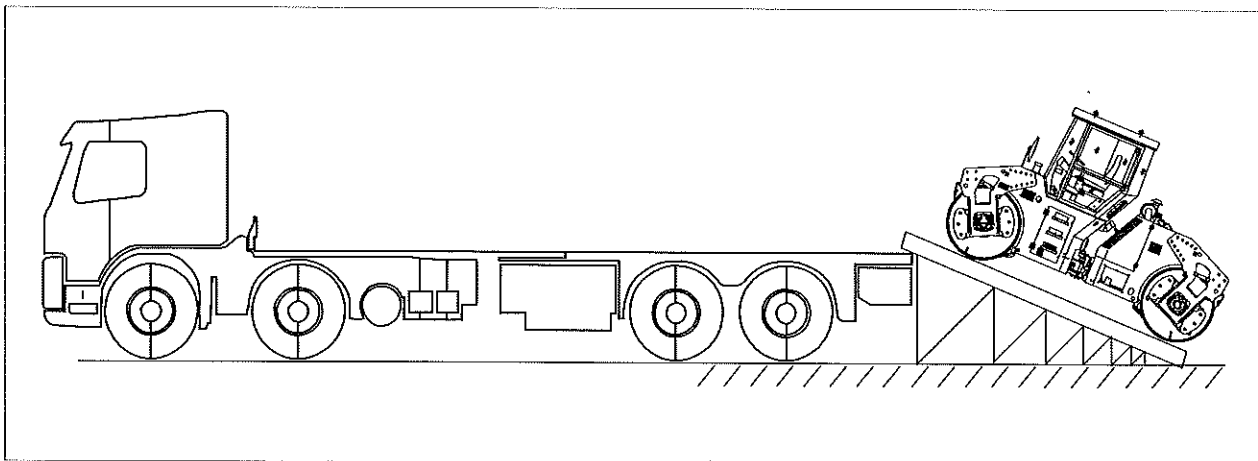

Fig.2-56

## 2.6.2 Transport the roller

Observe the local laws and regulations when transporting the equipment by highway.

Wedge the wheels with triangle wood blocks and fasten the roller with other measures during the transportation by sea and by road. Besides, drain the water tank of the diesel engine, reserve some fuel for loading, unloading and transportation, and then disconnect the circuit between the storage battery and the frame.

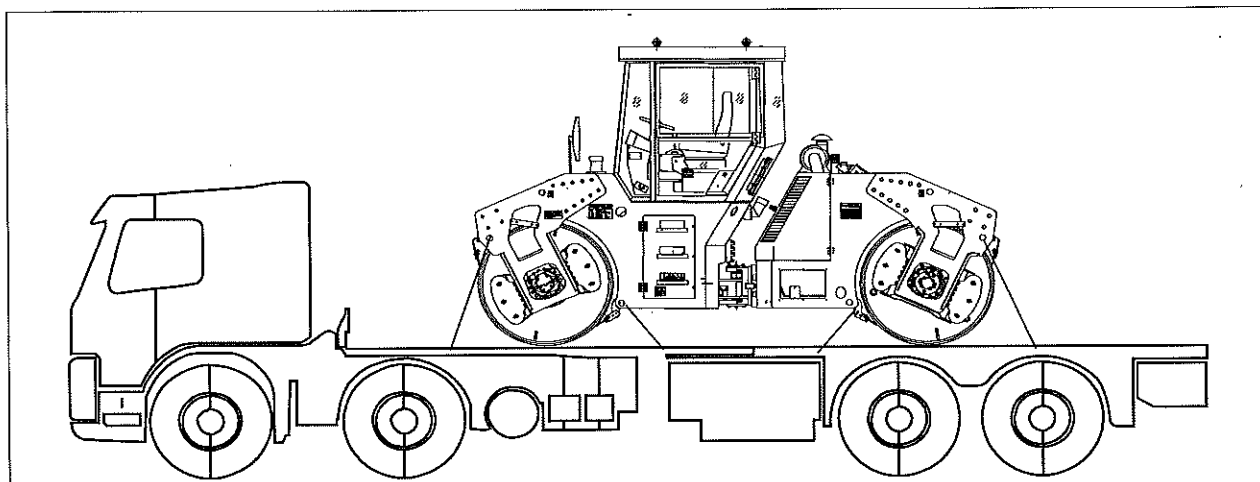

Fig.2-57

## 2.6.3 Lift the roller

Small-sized roller can be loaded to the truck by a crane.

- In any small-sized roller there are lifting eyes. Use qualified lifting hooks and ropes appropriately.

### **⚠ WARNING**

Improper lifting may cause damage to the machine, even severe personal injury or death.

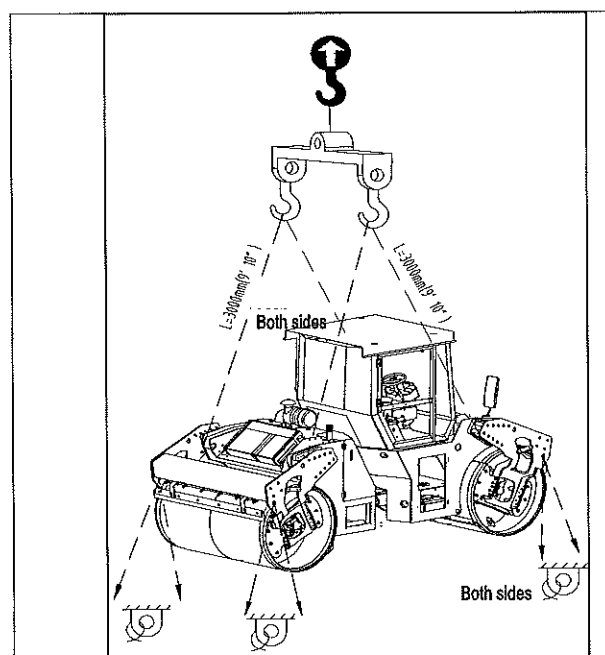

Fig.2-58

- Before lifting the roller, lock the center articulation frame by a limit pin to avoid turning.

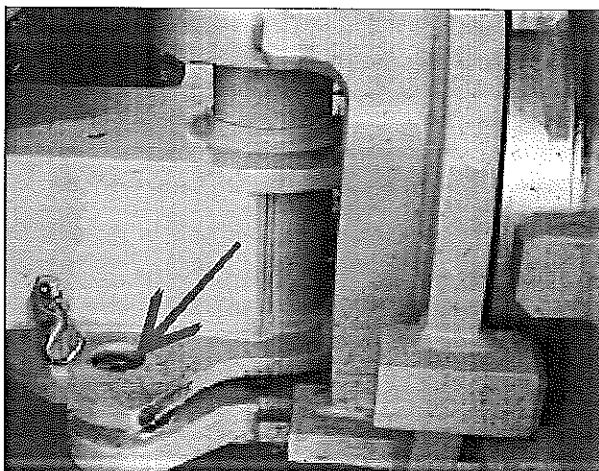

Fig.2-59

- The total weight of the roller is marked on the nameplate. **See: section 1.3.3 Equipment Information on page 1-5.** When lifting the roller, check the weight on the nameplate and operate in consistence with the safety regulations of the crane.

Blank page with horizontal dashed lines for writing.

BLANK PAGE

BLANK PAGE



# SANY

## System Function

### 3 System Functions

3.1 General Description .....	3-1
3.2 Display and Control Console .....	3-2
3.2.1 Display .....	3-3
3.2.2 Switches .....	3-18

**⚠ WARNING**

**Read and understand all safety precautions and instructions in this manual before reading any other manuals provided with this roller and before operating or servicing the roller. Failure to do this can cause property damage, personal injury or death.**

---

## 3 SYSTEM FUNCTIONS

### 3.1 General Description

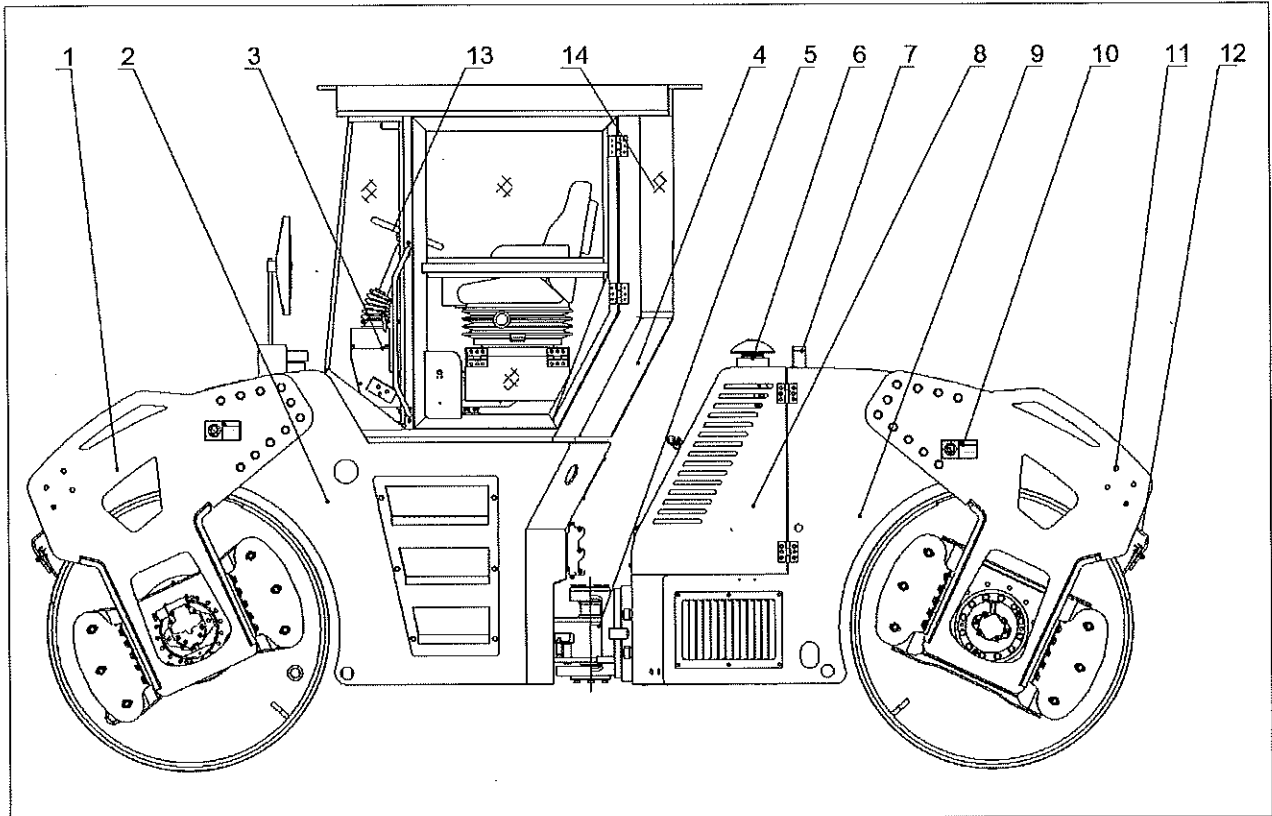

- |                                      |   |
|--------------------------------------|---|
| 1-Vibratory drum assembly            | 8- Covering parts                               |
| 2-Front frame                        | 9- Rear frame                                   |
| 3-Rotary console assembly            | 10- Nameplates                                  |
| 4-Air conditioning system (optional) | 11- Beam components                             |
| 5-Central articulation frame         | 12- Water spraying system                       |
| 6-Engine system                      | 13- Electrical system                           |
| 7-Hydraulic system                   | 14- Control platform assembly (Cab is optional) |

Fig.3-1

Above figure is for reference. Clients may select cab, A/C system or other parts as demanded by construction conditions. For actual configuration, the delivered machine shall prevail.

## 3.2 Display and Control Console

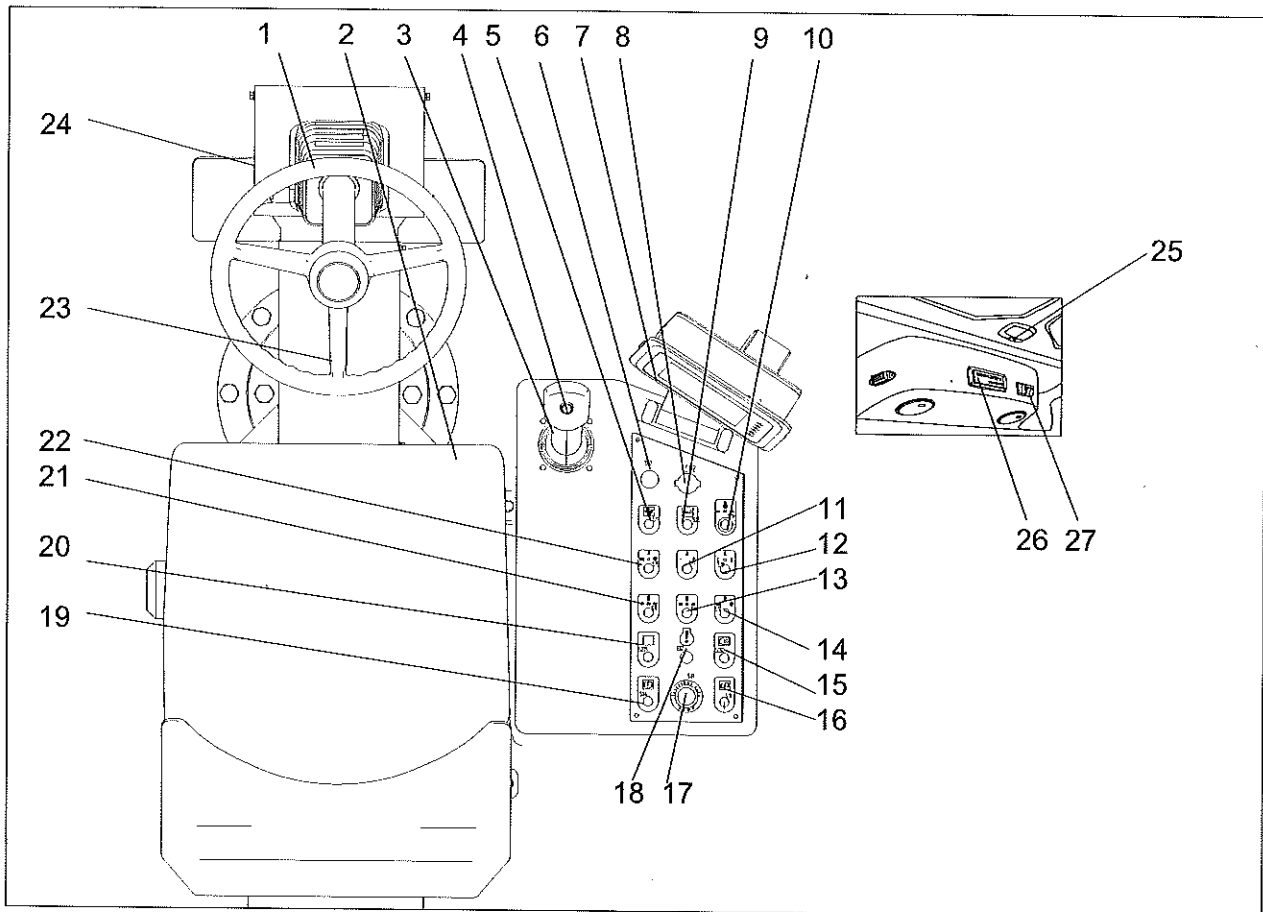
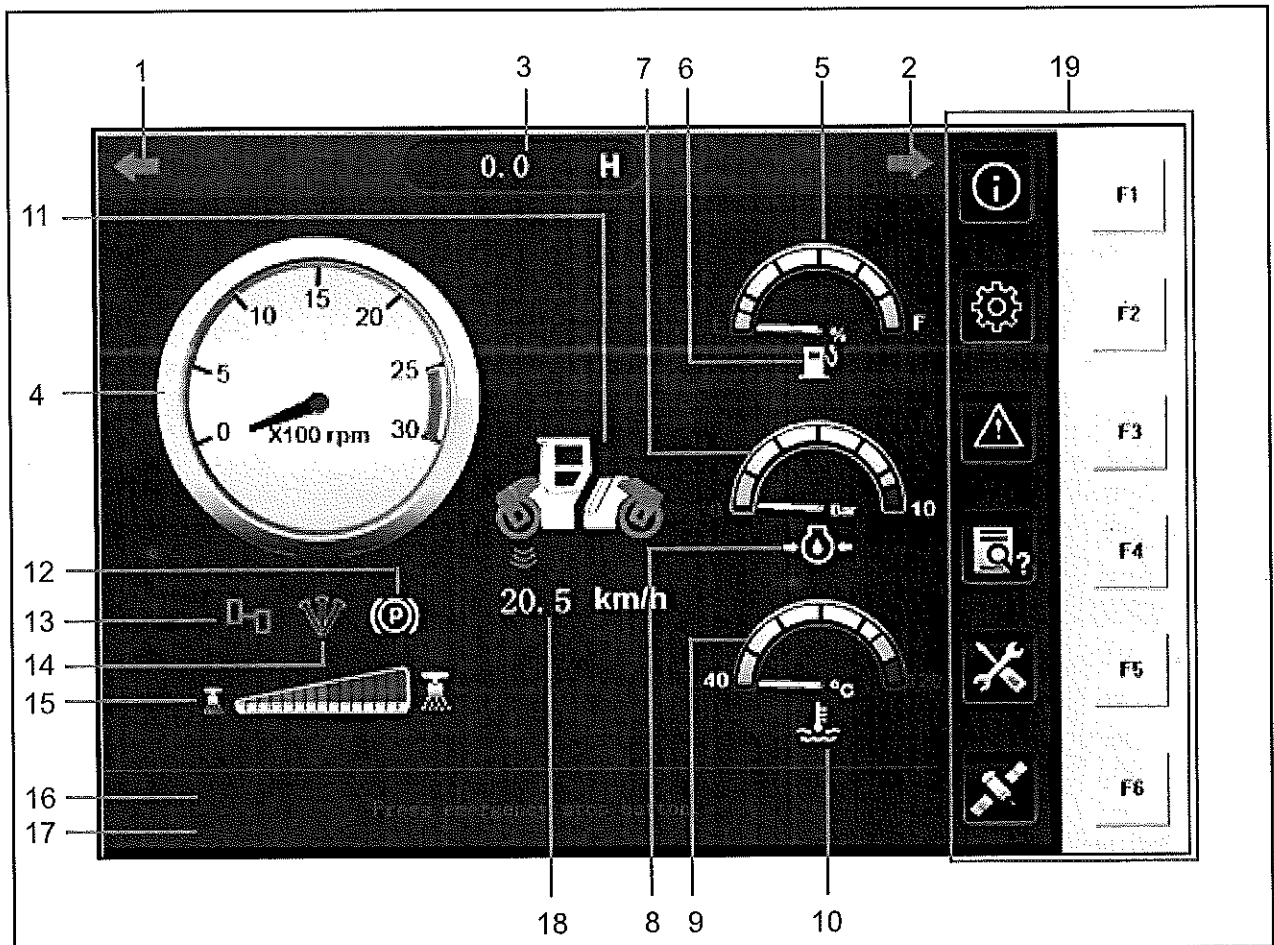

Fig.3-2

- |  |   |
|--|---|
| 1- Steering wheel                          | 15- Rear working light switch             |
| 2- Seat                                    | 16- Crablike travel control switch        |
| 3- Propel control lever                    | 17- Emergency stop switch                 |
| 4- Vibration start/stop button             | 18- ECU alarm lamp                        |
| 5- Gear selection switch                   | 19- Parking brake switch                  |
| 6- Panel plug                              | 20- Front working light switch            |
| 7- Display                                 | 21- Vibration mode selection switch       |
| 8- Ignition switch                         | 22- Manual/auto spraying selection switch |
| 9- Turn indicator switch                   | 23- Seat rotation control lever           |
| 10- Throttle control knob                  | 24- Steering wheel adjustment lever       |
| 11- Water flow control switch              | 25- Dome light switch                     |
| 12- Water pump selection switch            | 26- Radio control panel                   |
| 13- Vibration frequency selection switch   | 27- Wiper/washer switch                   |
| 14- Manual/auto vibration selection switch |   |

Above figure is for reference, which contains optional parts. For actual configuration, the delivered machine shall prevail.

3.2.1 Display

















- |                              |   |
|------------------------------|---|
| 1- Left turn indicator icon  | 10- Water temperature alarm             |
| 2- Right turn indicator icon | 11- Model and vibration status          |
| 3- Operating hours           | 12- Parking brake indicator icon        |
| 4- Engine speedometer        | 13- Crablike travel indicator icon      |
| 5- Fuel gauge                | 14- Neutral position indicator icon     |
| 6- Fuel level alarm          | 15- Spraying status indication          |
| 7- Engine oil pressure gauge | 16- Emergent spraying indication        |
| 8- Engine oil pressure alarm | 17- Alarm information prompt            |
| 9- Water temperature gauge   | 18- Running speed indication            |
|                              | 19-Functional buttons and icons (F1-F6) |

Fig.3-3

The roller adopts the special SANY colorful liquid crystal display (SYLD) to display actual working status, key parameters, maintenance information and alarm information, and to set parameters.

Table 3-1 Meanings of icons for tandem roller series

No.	Icons	Name	Description
1		Left turn indicator icon	Switch the turn light to left, and its indicator goes on. Switch the turn light to "0" position, and its indicator goes off.
2		Right turn indicator icon	Switch the turn light to right, and its indicator goes on. Switch the turn light to "0" position, and its indicator goes off.
3		Operating hours	It indicates the actual operating hours.
4		Engine speedometer	It indicates the actual engine speed.
5		Fuel gauge	It indicates the actual fuel level.
6		Fuel level alarm	When the fuel is less than 10%, it flashes in red.
			When the fuel is more than 10%, it flashes in white.
7		Engine oil pressure gauge	It indicates the actual engine oil pressure.
8		Engine oil pressure alarm	When the engine is off and the engine oil pressure is too low, it is in red.
			When the engine is on and the engine oil pressure is too low, it flashes in red. You shall stop the roller to check it. When the engine oil pressure is normal, it is in white.
9		Water temperature gauge	It indicates the actual water temperature of engine.
10		Water temperature alarm	When the water temperature sensor gives warn, it flashes in red.
			When the water temperature is normal, it is in white.
11		Model and vibration status indication	When it is a model of STR series, the icon of the tandem roller appears.
			It indicates the status of front wheel vibration and manual vibration.





















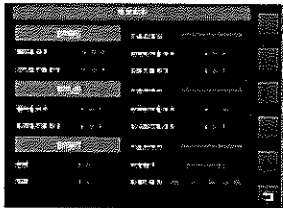
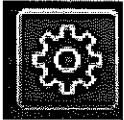
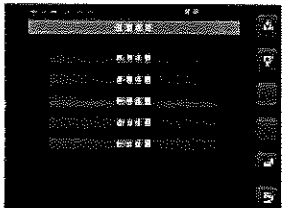

No.	Icons	Name	Description
11		Model and vibration status indicator	It indicates the status of two-wheel vibration and manual vibration.
			It indicates the status of rear wheel vibration and manual vibration.
			It indicates the dynamic status for the output of the high/low frequency solenoid.
12		Parking indicator	When the parking switch is in "P" position, the indicator lights up in red.
			When the parking switch is in "0" position, the indicator lights up in white.
13		Crablike travel indicator	When the function of crablike travel is on, it is in green.
			When the function of crablike travel is on and the relative solenoid has no output, it is in white.
14		Neutral position indicator	When the propel level is in the neutral position, it lights up in green.
			When the propel level is off the neutral position, it lights up in white.
15		Water spraying status indicator	It indicates the actual gear from 0 to 16.
16		Emergent water spraying indicator	It indicates the remaining time to stop water spraying because of low water level.
17		Alarm information	It indicates actual alarm information scrolling on the display.
18		Running speed indicator	It indicates the actual travel speed.
19		Functional keys	Refer to Table 3-2.

Table 3-2 Functional keys

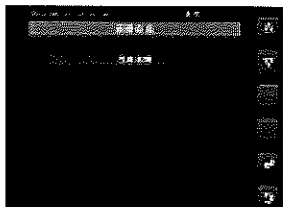
Icon	Keys	Target Page	Content
	F1		<p>System information page:                      SYMC controller, SYCD display, GPS information including serial number, versions of software and hardware, longitude and latitude.</p>
	F2		<p>Setting page:                      It requires a password and includes model configuration, parameter setting, hour setting, language setting and time zone setting.</p>
	F3		<p>Fault information page:                      Current fault information.</p>
	F4		<p>Interface status page:                      Digit input or output, analog status.</p>
	F5		<p>Maintenance page:                      Maintenance certify page, maintenance content page, maintenance history page and maintenance password page.</p>
	F6		<p>GPS information page:                      it indicates the actual GPS status and relative information prompts.</p>

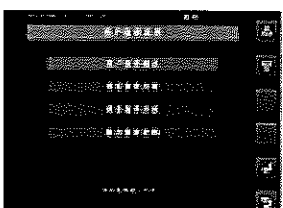

### System Information Page

Press F1 on the homepage into the system information page. This page displays information of SYMC, SYCD, GPS, hardware version, software version and program version.

Functions of the key:

Icon	Key	Function
	F6	Return to the homepage

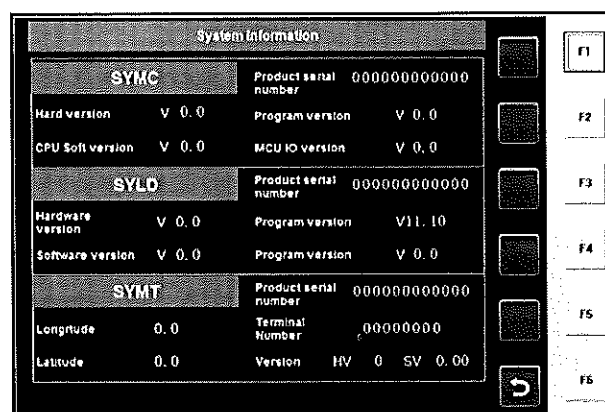

Fig.3-4

### System Password Page

Press F2 on the homepage, and then the password page will pop up. After you input the correct password, the display will show the setting page.

Functions of keys:

Icon	Keys	Functions
	F1	To move leftwards
	F2	To move rightwards
	F3	To increase the number at the chosen position
	F4	To decrease the number at the chosen position
	F5	Enter
	F6	To return to homepage

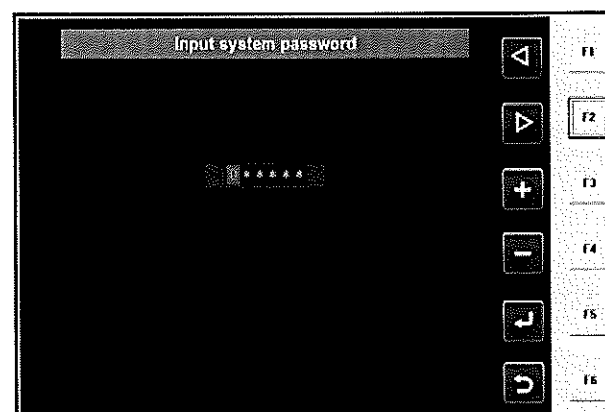

Fig.3-5

### System Setting Page

A fixed password is required for entering this page. Press F2 on the homepage into the password page. This page displays roller type setting, parameter setting, system time setting, language setting, language setting and time zone setting.

Functions of keys:

Icon	Keys	Functions
	F1	To move upwards
	F2	To move downwards
	F5	Enter
	F6	To return to homepage

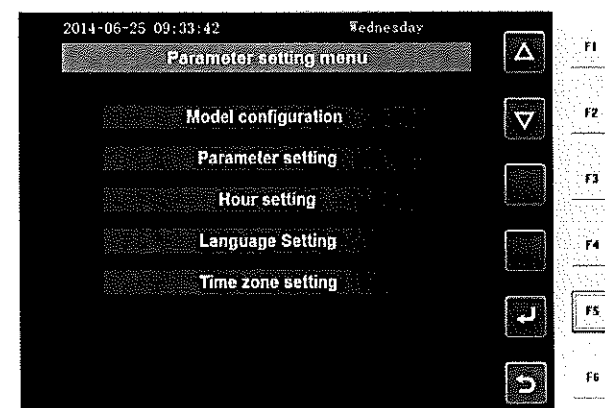

Fig.3-6

**Model Configuration Page**

Press the item of model configuration page on the system setting page and enter the model configuration page. For initial start or having replaced the controllers and the display, the system shall be reset for its corresponding model and serial number, and types of hydraulic pump, motor, reducer, engine, fuel sensor.

After having replaced engine, pump, motor, reducer or fuel sensor, reset parameters. After modification, "Configurating, wait....." is shown on the display. After 5-10 seconds, "configuration has been done" prompts up if modification is done. If not, "Configuration has not been done. Please check CAN communication" prompts up. Check CAN communication according to the prompt.

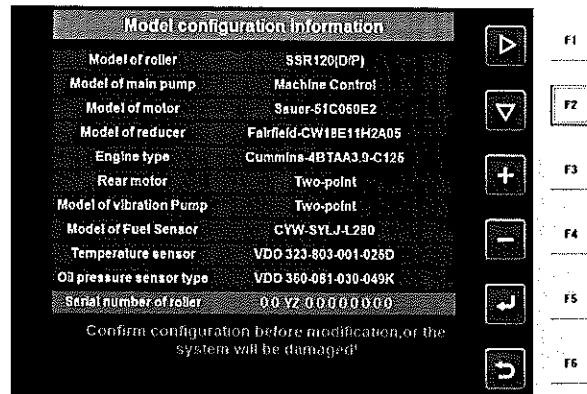

Fig.3-7

**NOTICE**

Confirm setting before any modification. If any parameters do not confirm to components, the system will not work, and even components will be damaged. Be cautious!







Functions of keys:

Icon	Keys	Functions
	F1	To move rightwards
	F2	To move downwards
	F3	To increase the number at the chosen position
	F4	To decrease the number at the chosen position
	F5	Enter
	F6	To return to System Setting Page

**Parameter Setting Page**

Press the item of parameter setting page on the system setting page and enter the model configuration page. Parameters include Brake delay time, Maximum start time, Water spraying interval and Sprinkle pump type. Enter F5 to confirm.

Functions of keys:

Icon	Keys	Functions
	F1	To move rightwards
	F2	To move downwards
	F3	To increase the number at the chosen position
	F4	To decrease the number at the chosen position
	F5	Enter
	F6	To return to the system setting page

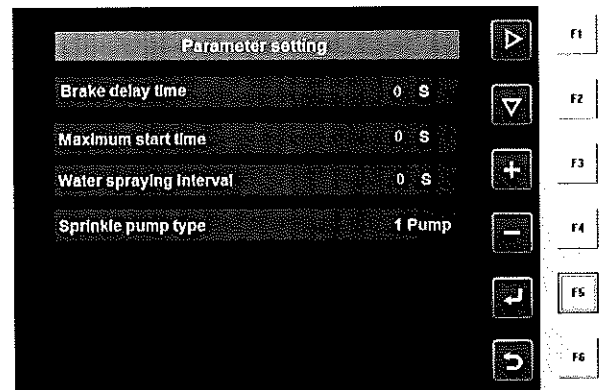







Fig.3-8

**Time Setting Page**

Press the item of system time setting page on the system setting page. After the display is on, the system time will be automatically upgraded through GPS. This page is used for the user to directly set the current date and time.

Functions of keys:

Icon	Keys	Functions
	F1	To move rightwards
	F2	To move downwards
	F3	To increase the number at the chosen position
	F4	To decrease the number at the chosen position
	F5	Enter
	F6	To return to the system setting page

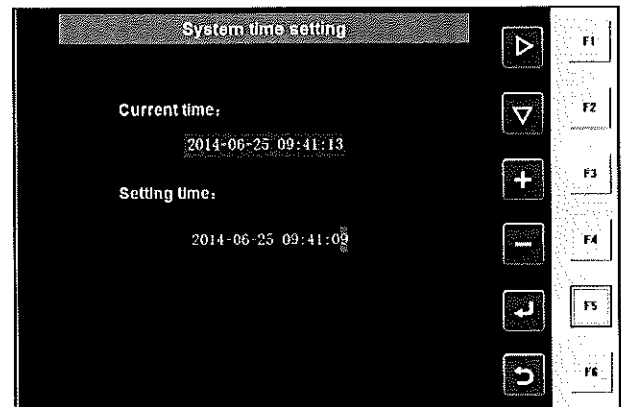





Fig.3-9

### Language Setting Page

Press the item of language setting page on the system setting page to enter the page. Chinese, English, Spanish, Russian, Portuguese, French are available. Press F5 to confirm.

Functions of keys:

Icon	Keys	Functions
	F1	To move upwards
	F2	To move downwards
	F5	Enter
	F6	To return to the system setting page

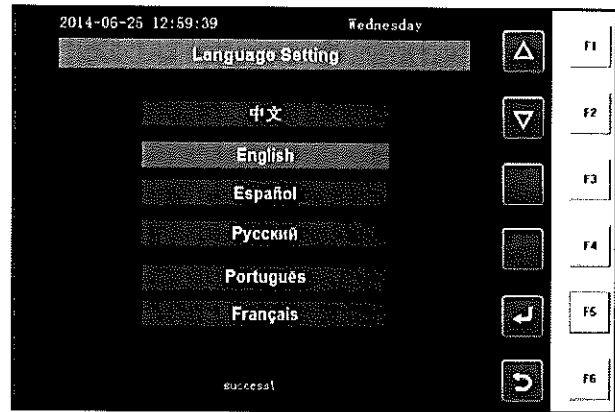







Fig.3-10

### Time Zone Setting Page

Press the item of time zone setting on the system setting page. The user can choose local time zone based on his demand. The system default is GMT+8.

Functions of keys:

Icon	Keys	Functions
	F1	To move rightwards
	F2	To move downwards
	F3	To move time zone upwards
	F4	To move time zone downwards
	F5	Enter
	F6	To return to the system setting page

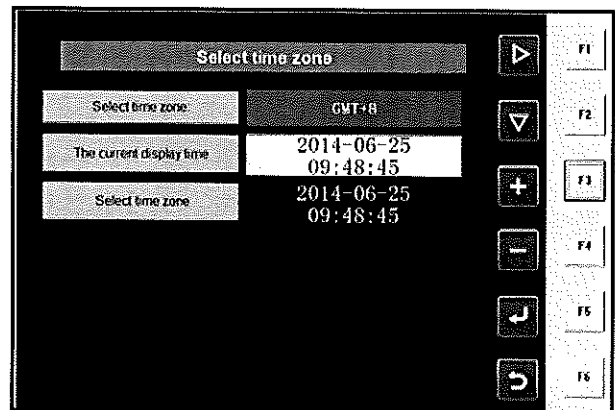





Fig.3-11

### Inquiry page

Press F4 on the homepage to enter this page. You can see items of input switch, output switch, analog IO and work record.

Functions of keys:

Icon	Keys	Functions
	F1	To move upwards
	F2	To move downwards
	F5	Enter
	F6	To return to homepage

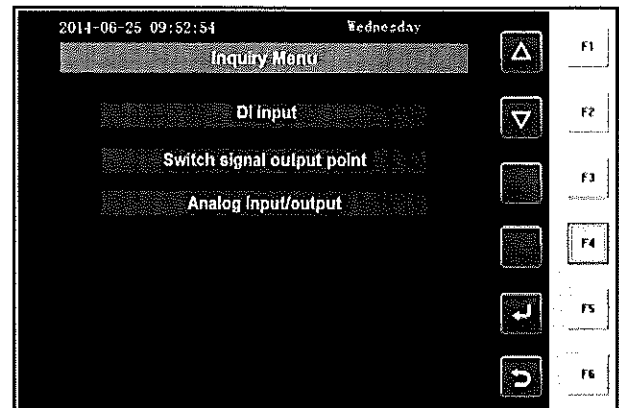



Fig.3-12

### Switch Signal Input page

Press the item of switch signal input point on inquiry page to enter this page. You can review input status of switch signal. If the signal is "true", the icon is green. If the signal is "false", the icon is "grey".

Functions of keys:

Icon	Keys	Functions
	F1	To move upwards
	F6	To return to inquiry page.

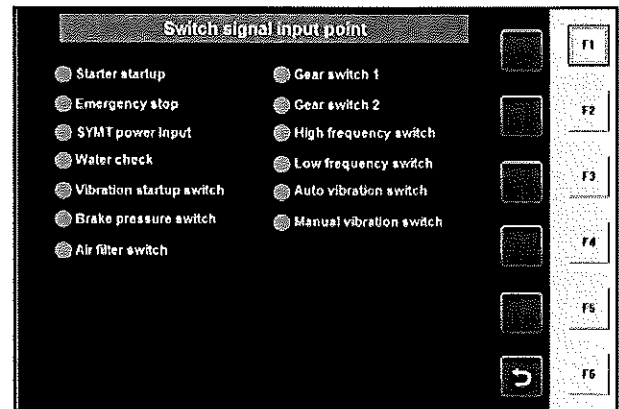

Fig.3-13

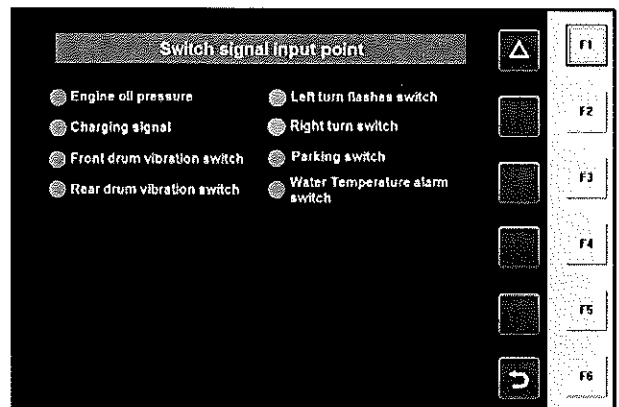

Fig.3-14

### Switch Signal Output Page

Press the item of switch signal output point on inquiry page to enter this page. You can review output status of switch signal. If the signal is "true", the icon is green. If the signal is "false", the icon is "grey". IO fault diagnosis function is available on this page, including open circuit, short circuit and normal circuit for immediate troubleshooting.

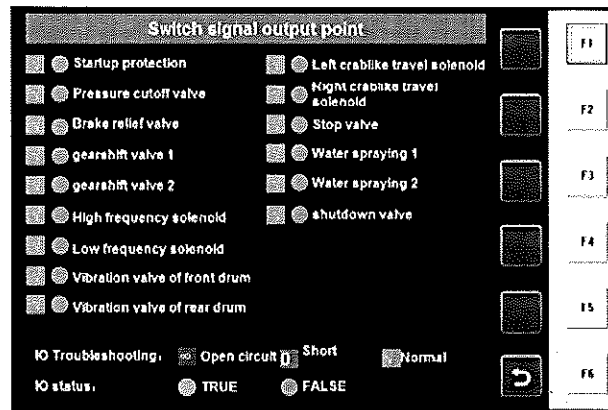

Fig.3-15

Functions of keys:

Icon	Keys	Functions
	F6	To return to the inquiry page

### Analog IO page

Press the item of Analog IO on inquiry page to enter this page. You can view analog of fuel, water temperature, engine oil pressure, engine speed pulse.

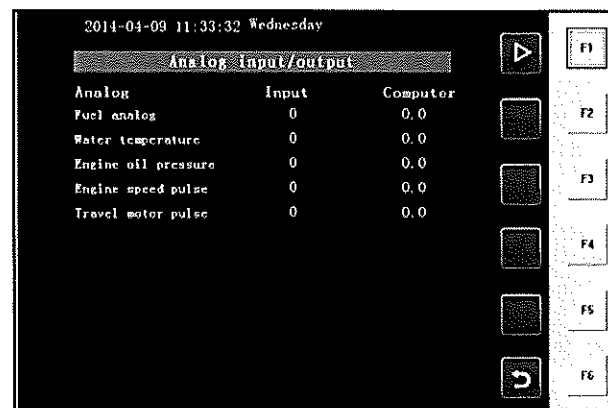

Fig.3-16

Functions of keys:

Icon	Keys	Functions
	F6	To return to the inquiry page

### Error information page

Press F3 on the homepage to enter this page.

Functions of keys:

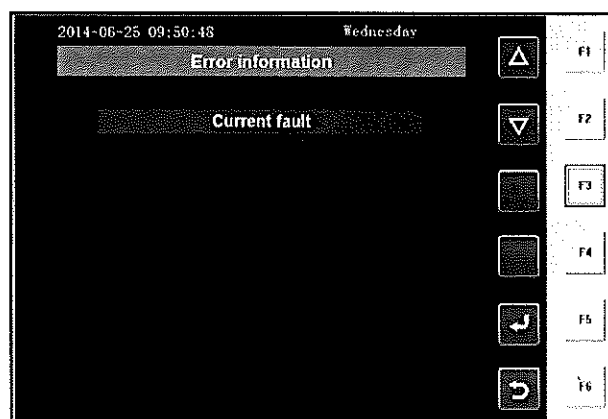



Fig.3-17

Icon	Keys	Functions
	F1	To move upwards
	F2	To move downwards
	F5	Enter
	F6	To return to homepage

**Current Error Page**

Press the item of current error page on the error information page to check the current error.

Functions of keys:

Icon	Keys	Functions
	F2	To the next page
	F6	To return to the error information page

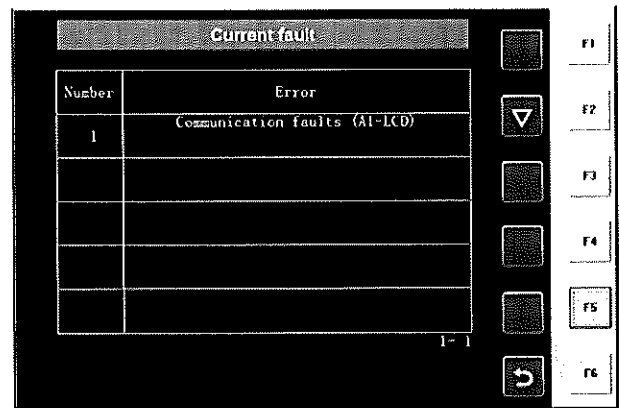





Fig.3-18

**Maintenance menu page**

Press F5 on the homepage to enter maintenance menu page. You can view maintenance certify, maintenance content, maintenance history and maintenance password.

Functions of keys:

Icon	Keys	Functions
	F1	To move upwards
	F2	To move downwards
	F5	Enter
	F6	To return to homepage

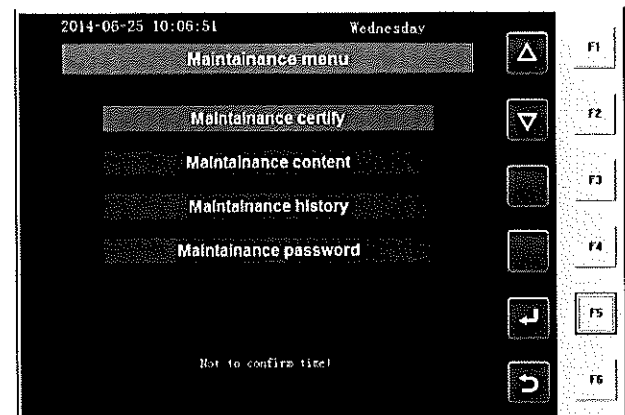







Fig.3-19

**Maintenance certify page**

Press the item of maintenance certify on maintenance menu page to enter this page. When it comes to each maintenance time, input the password for confirmation. If it is not yet to each maintenance time, a prompt will display.

Functions of keys:

Icon	Keys	Functions
	F1	To move rightwards
	F2	To move leftwards
	F3	To increase the number at the chosen position
	F4	To decrease the number at the chosen position
	F5	Enter
	F6	To return to the maintenance menu page

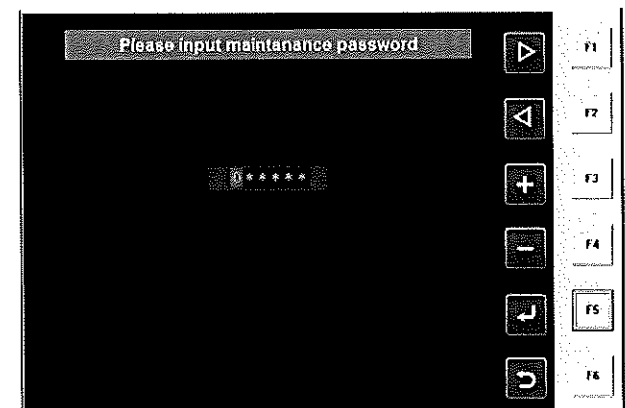

Fig.3-20

**Maintenance content page**

Press the item of maintenance content on maintenance menu page and enter this page. You can view detailed contents of each maintenance interval, including initial 50h maintenance, 250h maintenance, 500h maintenance, 750h maintenance, and 1000h maintenance. Once the roller runs up to a certain maintenance interval and after the system is on, the relative maintenance content will prompt up until the required maintenance is confirmed with the correct password.

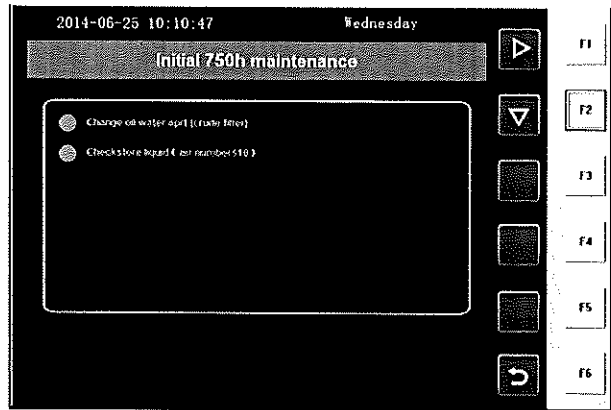

Fig.3-21

Functions of keys:

Icon	Keys	Functions
	F1	To move rightwards
	F2	To move downwards
	F6	To return to maintenance menu page

**Maintenance history page**

A password is required for entering this page. You can view historical maintenance information.

Functions of keys:

Icon	Keys	Functions
	F1	To move upwards
	F2	To move downwards
	F5	Enter
	F6	To return to maintenance menu page

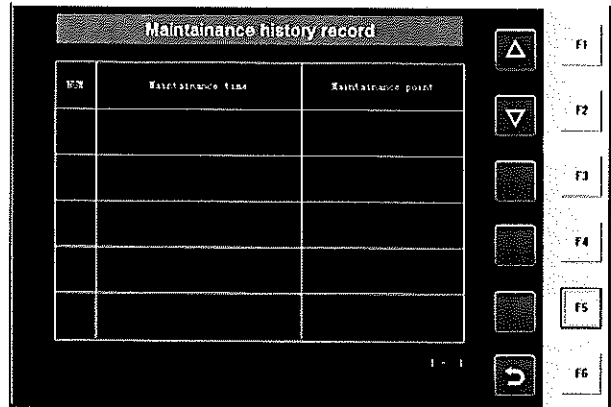







Fig.3-22



**Maintenance Password Page**

A password is required for entering this page. Input the old password first. Then input the new password, and certify it again. Press F5 to save the new password.

Functions of keys:

Icon	Keys	Functions
	F1	To move rightwards
	F2	To move downwards
	F3	To increase the number at the chosen position
	F4	To decrease the number at the chosen position
	F5	Enter
	F6	To return to maintenance menu page

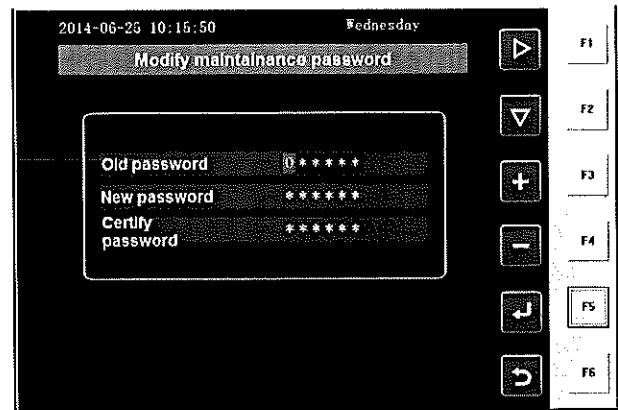

Fig.3-23

**GPS Information Page**

Press F6 on the homepage to enter the page.

You can view the status of GPS:

- Forbidden remote and local machine locking;
- Forbidden remote machine locking but allowable local machine locking;
- Allowable remote machine locking but forbidden local machine locking;
- Allowable remote and local machine locking. Any information on machine locking will prompt up. Operate it according to the prompt.

Functions of keys:

Icon	Keys	Functions
	F6	To return to homepage

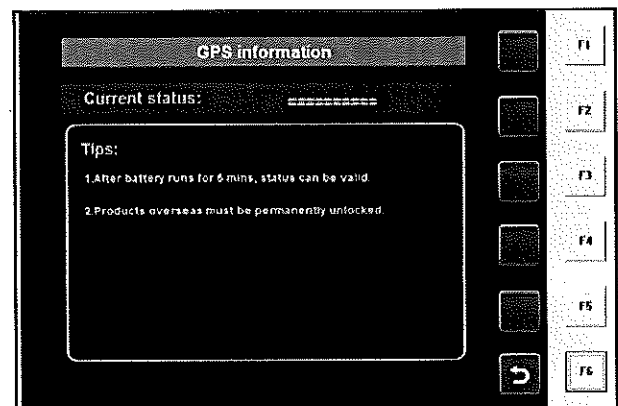

Fig.3-24

### Service Password Page

A service password is required for entering the service menu page. The password is generated according to the random guidance code. Record the guidance code and contact with relative personnel to get the password for modification.

Functions of keys:







Icon	Keys	Functions
	F1	To move leftwards
	F2	To move rightwards
	F3	To increase the number at the chosen position
	F4	To decrease the number at the chosen position
	F5	Enter
	F6	To return to homepage







Fig.3-25

### Service Menu Page

On this page, you can review relative service information including historical fault records, work records, operating hour revision and etc.

Functions of keys:

Icon	Keys	Functions
	F1	To move upwards
	F2	To move downwards
	F5	Enter
	F6	To return to homepage

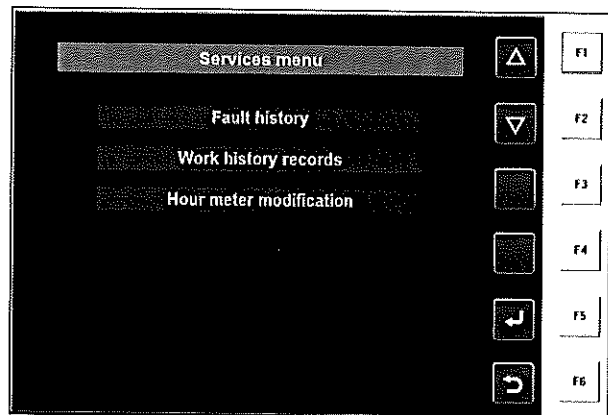

Fig.3-26

### Historical Faults Page

Choose the item of historical faults page on the service menu page. On this page, you can review relative time and codes of faults. Press F2 to check several historical faults.

Functions of keys:

Icon	Keys	Functions
	F2	To next page
	F6	To return to service menu page

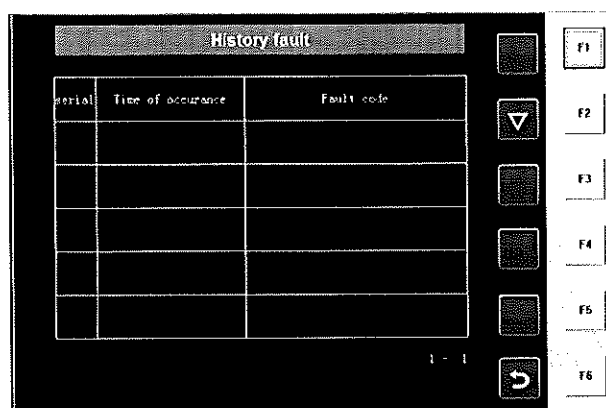

Fig.3-27

### Work Record Page

Press the item of work record on the service menu page to enter this page. You can view times of startup, low frequency time, high frequency time and running time at gears I, II, III and IV.

Functions of keys:

Icon	Keys	Functions
	F6	To return to service menu page

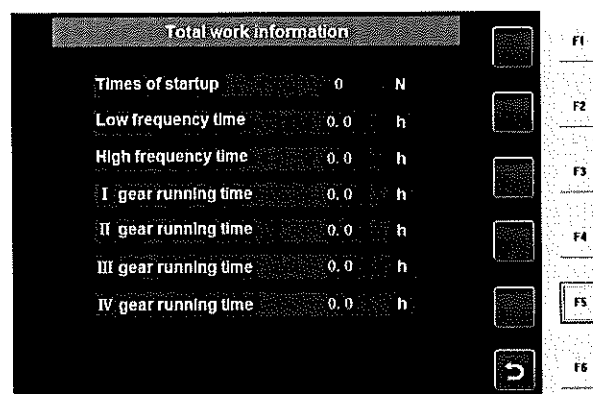

Fig.3-28

### Operating Hour Page

Press the item of operating hour page on the service menu page to enter this page. On this page, you can revise the operating hour.

Functions of keys:

Icon	Keys	Functions
	F1	To move leftwards
	F2	To move rightwards
	F3	To increase the number at the chosen position
	F4	To decrease the number at the chosen position
	F5	Enter
	F6	To return to homepage

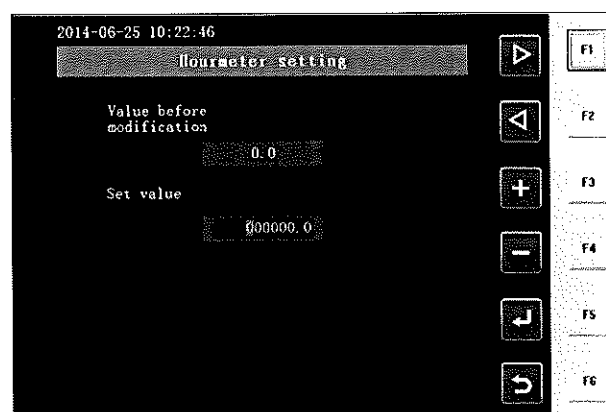

Fig.3-29

### 3.2.2 Switches

#### Turn indicator switch

When the roller is steering, turn the toggle switch to the target direction to warn people around. See the next figure for the location of the left turn light.

- Position (Left): the left turn light flashes;
- Position (Middle): the turn lights are off;
- Position (Right): the right turn light flashes.

**NOTE:** When the parking brake switch is applied, the turn lights flash.

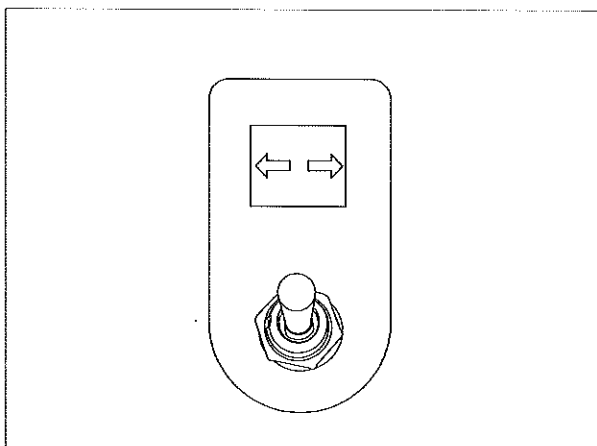

Fig.3-30

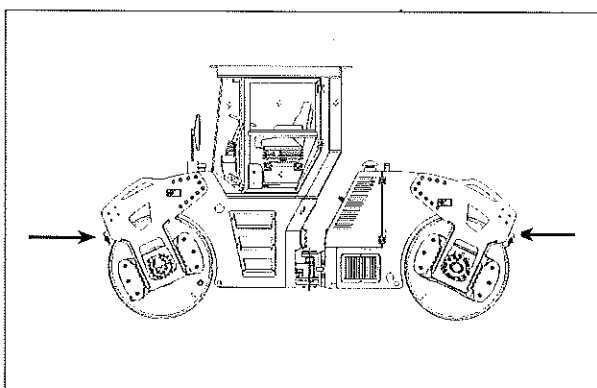

Fig.3-31

#### Gear selection switch

- Position (Up): High speed gear (rabbit).
- Position (Down): Low speed gear.

### NOTICE

**Before gearshift, assure the vibration has come to complete stop, or it may cause significant impact to the hydraulic system.**

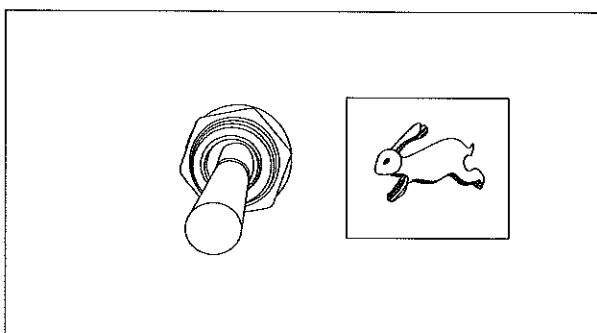

Fig.3-32

### Parking brake switch

- Position (Left): Parking brake is released;
- Position (Right): Parking brake is applied.

When parking the roller, operate the propel control lever to the "STOP" position to stop the roller slowly. Then rotate the parking brake switch to the "P" position to apply the parking brake.

Before starting the roller, assure that the propel control lever is in the "STOP" position, then rotate the parking brake switch to release the brake.

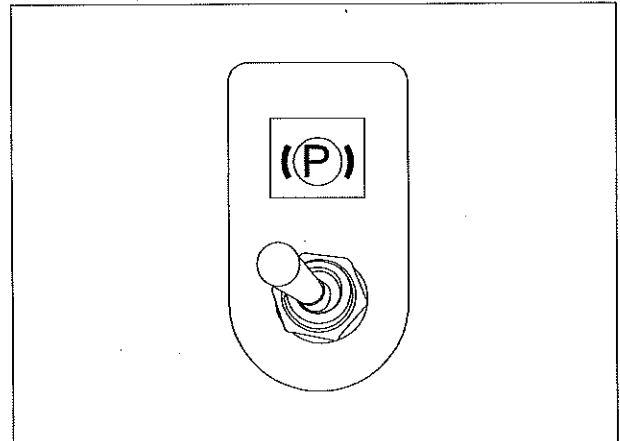

Fig.3-33

### Front working light switch

When the visibility conditions are poor, the front working lights should be switched on. The next figure shows the location of the front working lights.

- Position (Up): Front working lights are turned on.
- Position (Down): Front working lights are turned off.

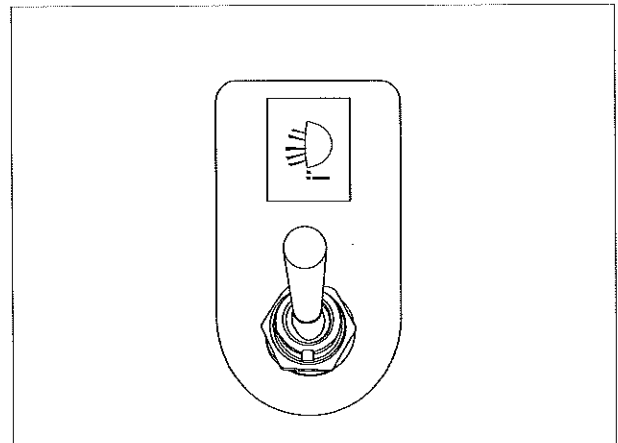

Fig.3-34

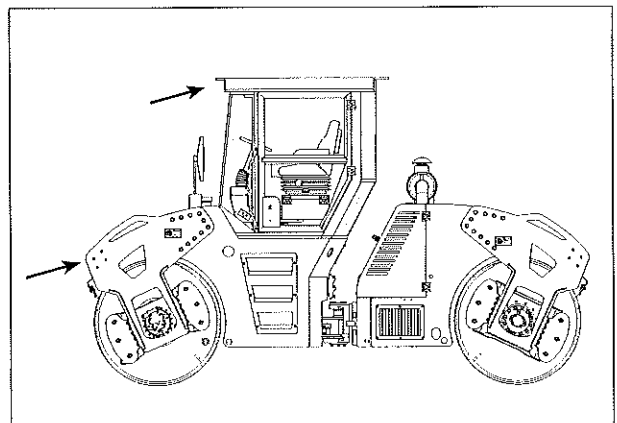

Fig.3-35

**Rear working light switch**

When the visibility conditions are poor, the rear working lights should be switched on. Fig.3-42 shows the location of the front working lights.

- Position (Up): Rear working lights are turned on.
- Position (Down): Rear working lights are turned off.

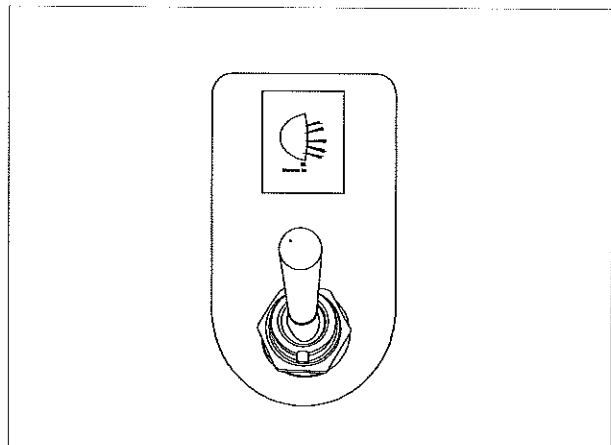

Fig.3-36

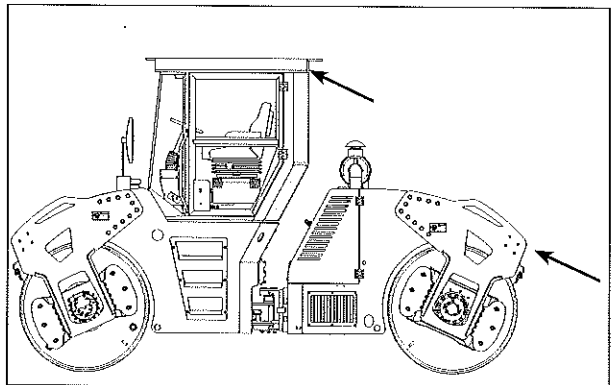

Fig.3-37

**Crablike travel control switch**

- Position (Left): the roller performs crablike travel leftwards;
- Position (Middle): the roller stops crablike travel;
- Position (Right): the roller performs crablike travel rightwards.

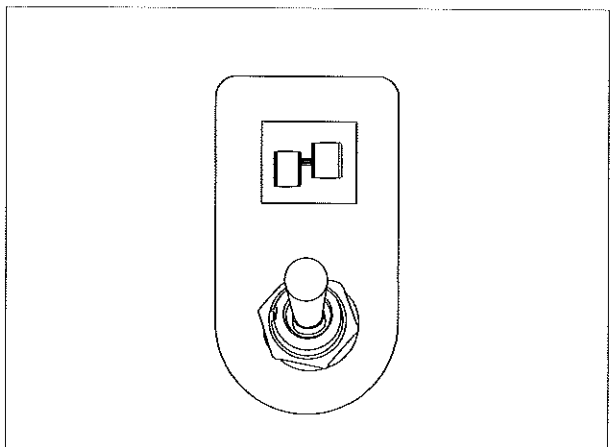

Fig.3-38

### Manual/auto vibration selection switch

- Position (Left): Manual. The vibration start is controlled by the vibration switch. Press the button and vibration starts. Press the button again and vibration stops.
- Position (Right): Auto. The vibration start is controlled by the driving speed. When the speed exceeds 1.5km/h, the vibration starts; when the speed is lower than 1.5km/h, the vibration stops.

### NOTICE

**Before switching the vibration mode, assure the vibration has come to complete stop, or it may cause significant impact to the hydraulic system.**

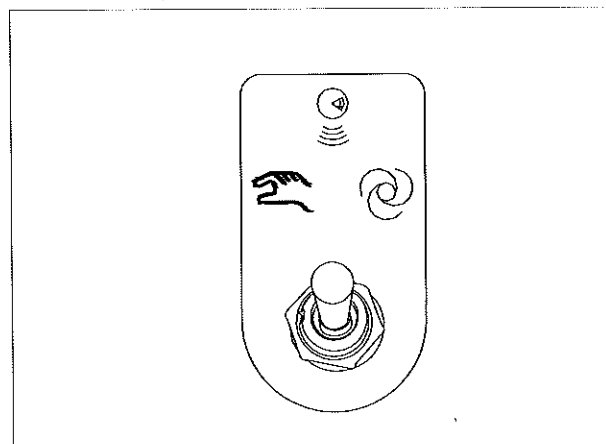

Fig.3-39

### Vibration frequency selection switch

When the throttle control knob is at "HI" position, vibration is at high frequency:

- Switch position (Left): High frequency, small amplitude and small centrifugal force.
- Switch position (Right): Low frequency, large amplitude and large centrifugal force.

When the throttle control knob is at "ECO" position, vibration is at normal frequency:

- Switch position (Left): High frequency, small amplitude and small centrifugal force.
- Switch position (Right): Low frequency, large amplitude and large centrifugal force.

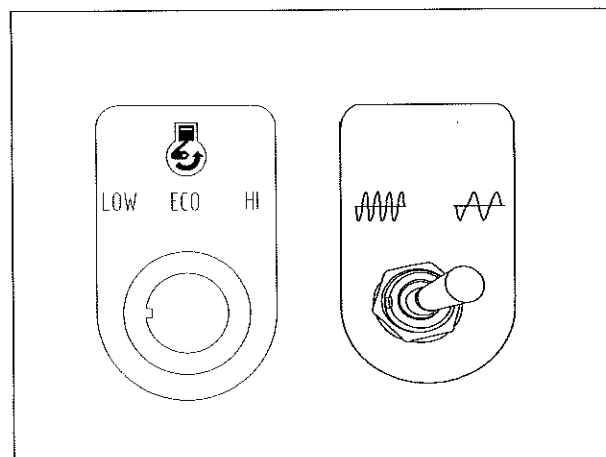

Fig.3-40

### NOTICE

**Before switching the frequency mode, assure the vibration has come to complete stop, or it may cause significant impact to the hydraulic system.**

### Vibration mode selection switch

- Position (Left): Only the front drum vibrates.
- Position (Middle): Two drums vibrate simultaneously.
- Position (Right): Only the rear drum vibrates.

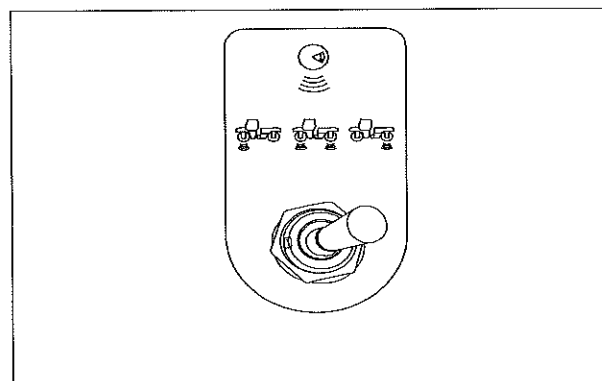

Fig.3-41

**Water pump selection switch**

Turn the switch to choose a water pump ( I # or II #).

- Position (Left): The water pump I # works.
- Position (Middle): The water pumps I # and II # work alternatively.
- Position (Right): The water pump II # works.

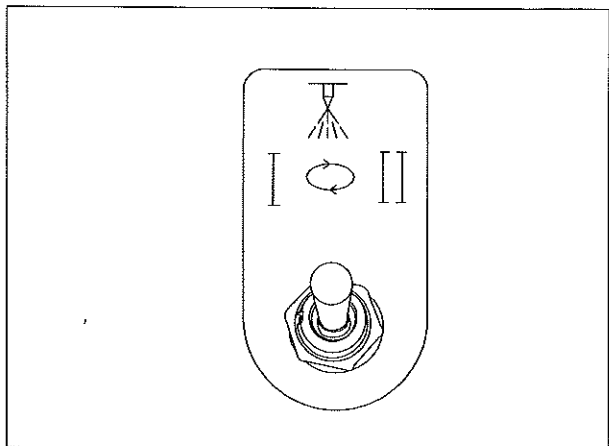

Fig.3-42

**Manual/auto spraying selection switch**

- Position (Left): Manual mode.
- Position (Middle): Water spraying stops.
- Position (Right): Auto mode. When the roller starts, water spraying starts.

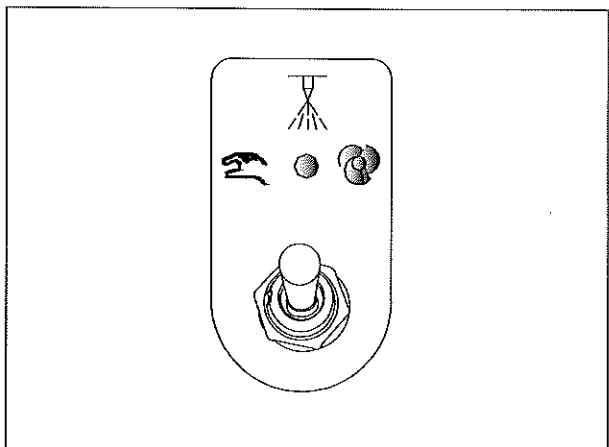

Fig.3-43

**Water flow control switch**

- Turn left: Water flow decreases.
- Turn right: Water flow increases.

**NOTE:** Turn the water flow control switch to the leftmost side to stop water spraying.

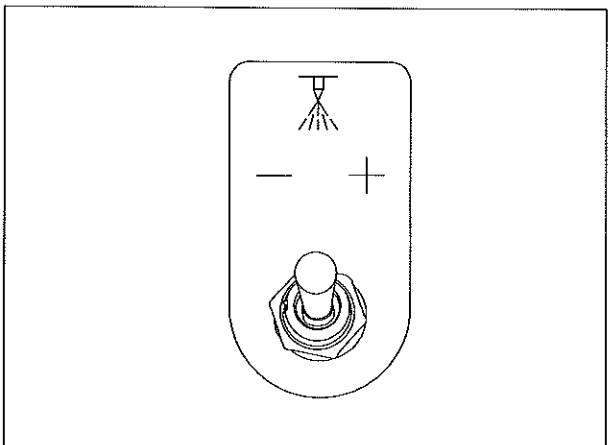

Fig.3-44



### Horn button

The horn can be used to inform or warn others to keep safe distance from the roller.

- Press down: The horn sounds.
- Release: The horn stops sounding.

**NOTE:** Consider local regulations may prohibit use of horns.

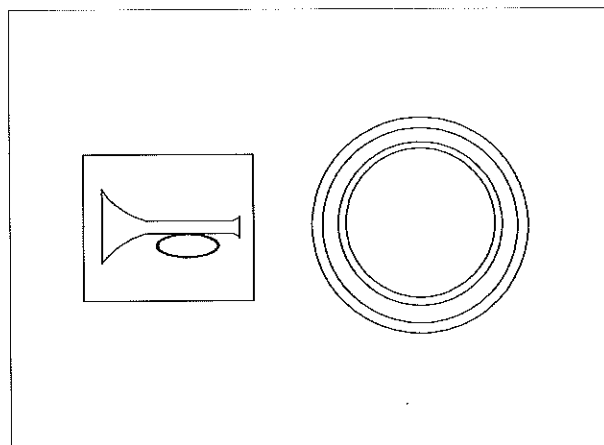

Fig.3-45

### Emergency stop switch

#### NOTICE

The emergency stop switch shall not be used as a service brake, or it will shorten the service life of the engine and other components.

- Press the switch down to shut down the engine.
- Rotate the switch clockwise to release the emergency stop.

If the roller needs to be restarted, first switch the propel control level to the neutral position and then power on the engine. Push the level to make the roller run.

**NOTE:** Only when the propel control level is in the neutral position, can the engine be started. Only after the troubleshooting has been eliminated, can the roller be started.

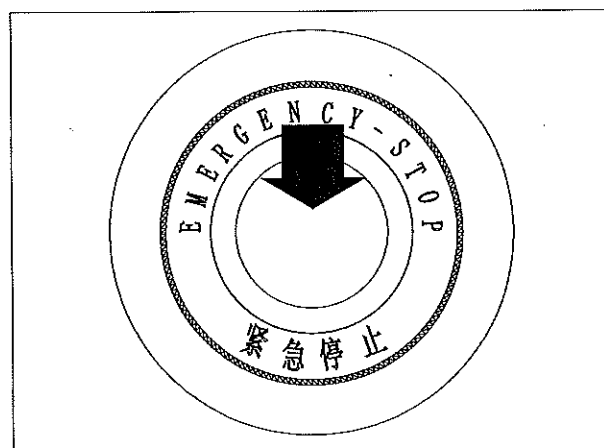

Fig.3-46

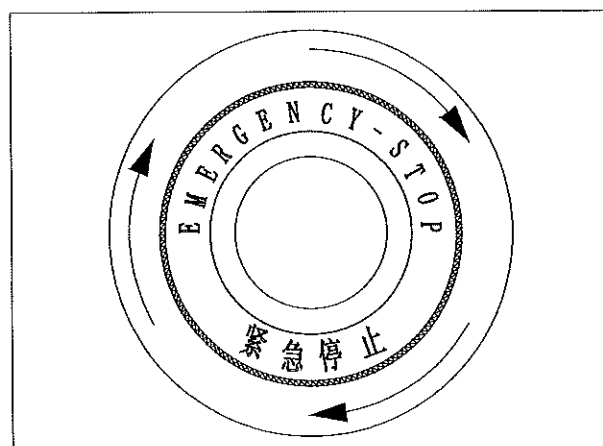

Fig.3-47

**Steering wheel**

Rotate the steering wheel to the target direction for the roller steering.

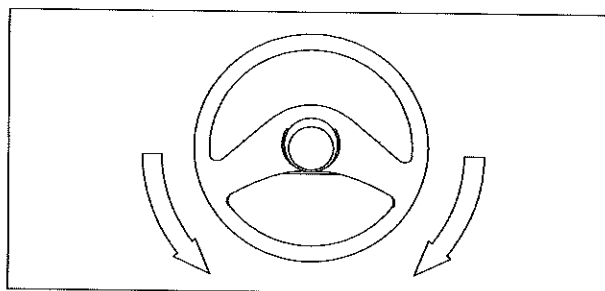

Fig.3-48

**Seat rotation control lever**

Push the seat rotation control lever forward to adjust the seat. When the seat is set at a target angle, release the control lever to lock the seat at the target angle.

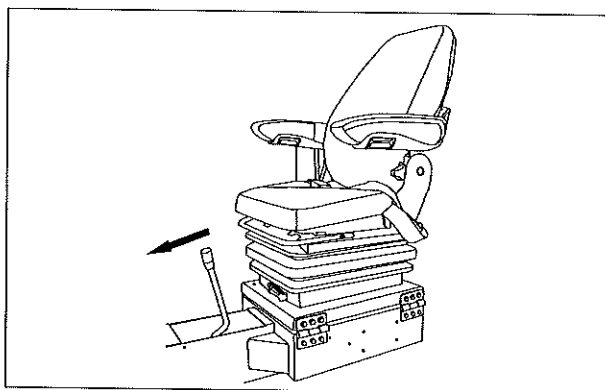

Fig.3-49

**Ignition key switch**

The ignition key switch is powering on or off the engine.

- Position (P/O): Stop position. It allows you to insert or remove the key. The electrical system is off and the engine is shut down.
- Position (I): Working position. The control system and circuits are energized. Keep the ignition key switch in the "I" position when operating the engine.
- Position (II): Preheating position. No preheating function.
- Position (III): Ignition position. Activates the starter, and keep the key in the "III" position. Until engine starts, release the key immediately after it is started. The key will return to the "I" position automatically.

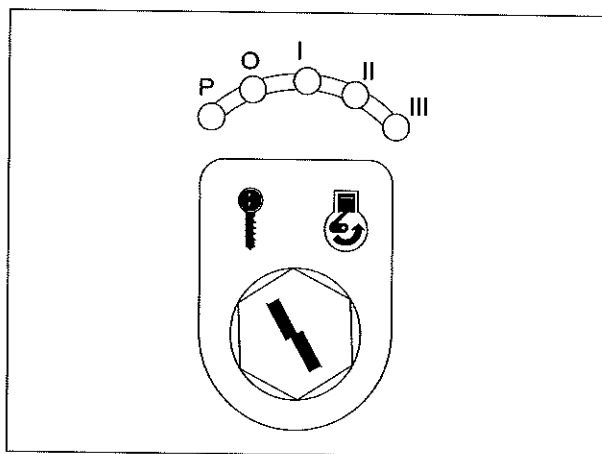

Fig.3-50

## NOTICE

If the engine does not stop at low idle speed, the service life of engine will be reduced. Except for emergency, do not shut off the engine while it is running at high speed, otherwise engine components may be damaged. Each starting time shall not exceed 10s and the interval shall be no less than 5min. If it cannot be started after 3 attempts continuously, stop starting and find out the cause, or it will shorten the service life of the engine.

### Throttle control knob

Turn the throttle control knob to adjust the throttle. When starting and stopping the engine, the throttle control knob should be at the "LOW" position to make the engine idle for 3-5 minutes.

When implement vibration, rotate the knob to "HI" position.

During transfer or static compaction, the knob may be turned to "ECO" position.

**NOTE:** If the roller has not been in use for a long time, the warmup time of the engine should be properly increased. During winter, the idle warmup time should be prolonged to 8-10min.

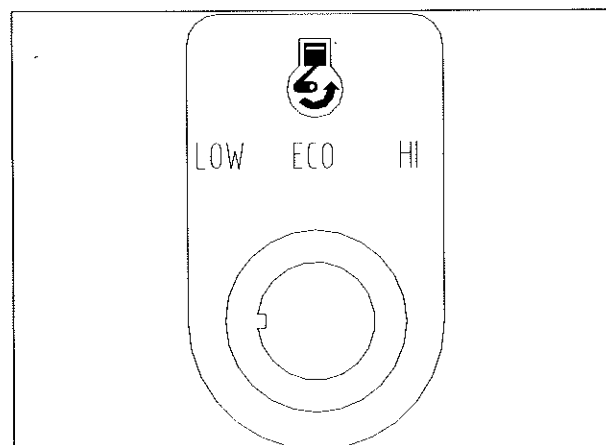

Fig.3-51

### Propel control lever

When engine starts, the propel control lever controls the movement of the roller.

- Position STOP: Roller stays stationary.
- Push forward from position STOP: Roller drives forward.
- Pull backward from position STOP: Roller drives reverse.

Deflection of the lever out of the "STOP" position determines the speed of the roller.

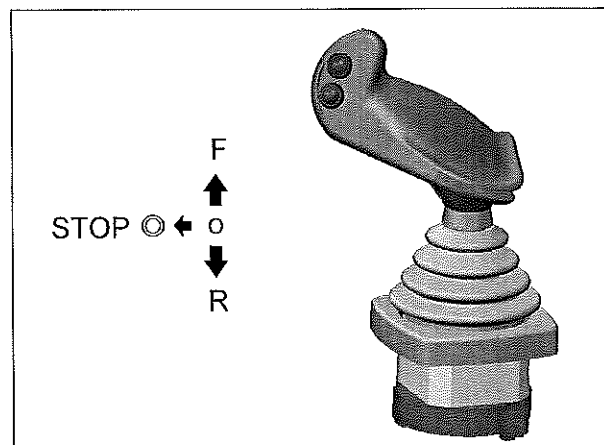



Fig.3-52

### Vibration start/stop button

The vibration button is installed on the propel control lever. When the vibration mode is set as MANUAL (  ), it controls directly the startup or shutoff of vibration.

- Press down: Vibration startup.
- Press again: Vibration shutoff.

## NOTICE

**Vibration shall be NOT operated while the roller is stationary. It will damage the bearings.**

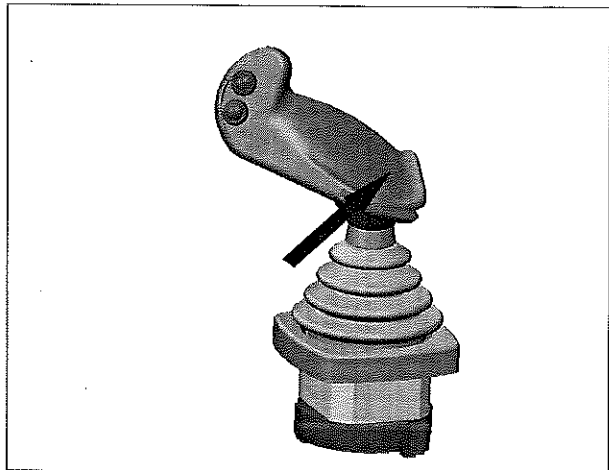

Fig.3-53

### Driver's seat

The driver's seat can be adjusted as follows.

- Forward and backward adjustment  
Pull the lever (A) upward, slide the seat to desired position, and release the lever.

- Backrest adjustment  
Lift lever (B), move the backrest to an optimum position at where operation can be easily conducted, and release the lever.

- Armrest angle adjustment  
Turning the plate beneath armrest can adjust the angle of armrest to the desired position. The armrest can be placed vertically so that the operator could leave the seat easily.

- Adjustment based on weight of operator  
Turn the lever (D) rightward for a heavier operator; Turn the lever (D) leftward for a lighter operator.

- Height adjustment  
The seat can be raised by 30 mm when you hear a "click" sound, and another 30 mm at the second "click". The seat can be lowered to the minimum height if you continue to raise it.

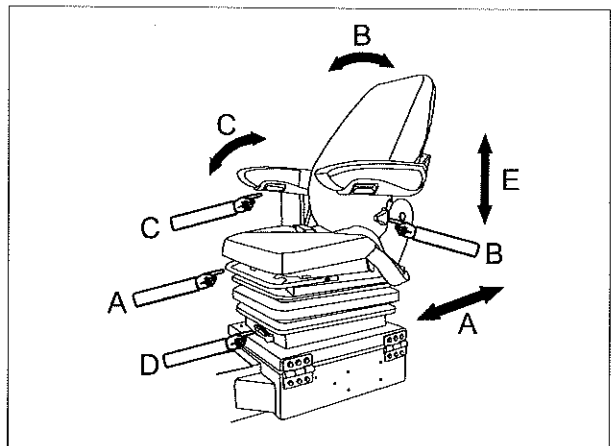

Fig.3-54

### Master power switch

The master power switch controls the power supply for the whole roller. Ensure to connect the master power switch before the engine is started. Disconnect the master power switch after daily work has been finished.



Fig.3-55

### Dome light switch

- Position (ON): The cab illumination is on.
- Position (OFF): The cab illumination is off.

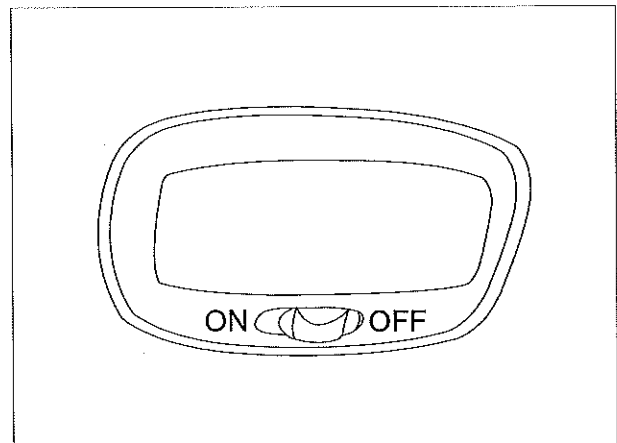

Fig.3-56

### A/C control panel (optional)

The A/C is mainly composed of evaporator, condenser, compressor, heat exchange valve and control panel. It can be used for cooling and warming. The control panel is above the evaporator.

Fan speed control switch: Adjust the fan speed.

- Position (O) : Off.
- Position (L) : Low fan speed.
- Position (M) : Medium fan speed.
- Position (H) : High fan speed.

Temperature control switch: Turning it can adjust the cooling temperature.

- Rotate clockwise: Reduce temperature.
- Rotate anticlockwise: Increase temperature.

Indicator: When it is on, it indicates the compressor has been started and the cooling system is working.

Four air vents are installed at the rear of the cab. Operate the switches on air vents to control the direction of air outlets.

### Cooling

1. Start the engine.
2. Turn the fan speed control switch to the "H" position for about 5 min.
3. Turn the temperature control switch to the "COOL" position.
4. When the temperature drops to the desired value, turn the temperature control switch anticlockwise slowly until the indicator goes off and the compressor stops. Now, the cabin temperature is the set temperature.
5. When the cab temperature exceeds this temperature, the Indicator is lit up, the compressor starts automatically and the system starts cooling again until the set temperature is reached.

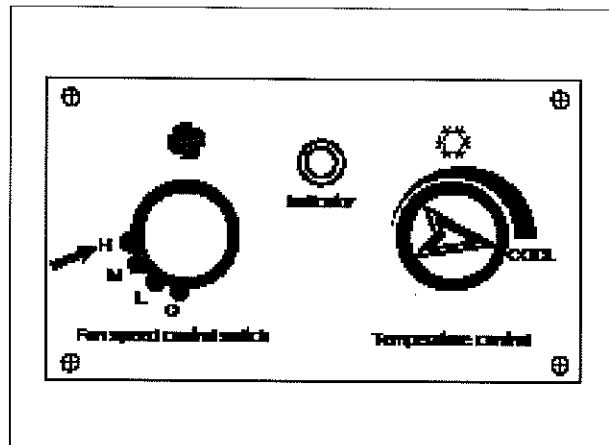

Fig.3-57

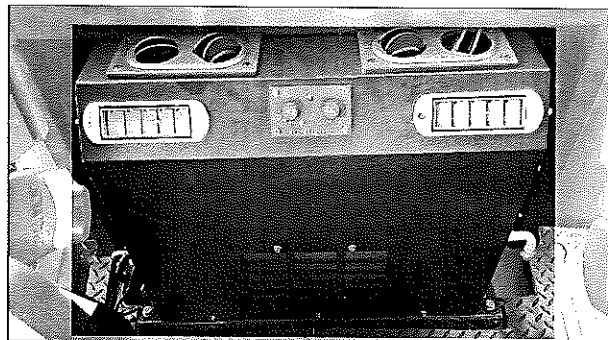

Fig.3-58

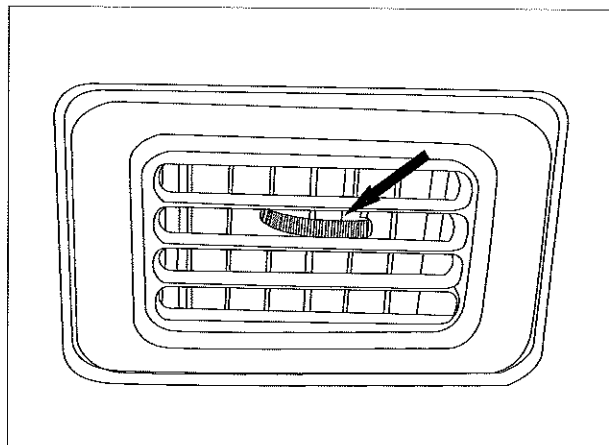

Fig.3-59

## NOTICE

**When the A/C is in use, never turn the temperature control switch to the "COOL" position while turning the fan speed control switch to the "L" position. This will lead the evaporator to frost.**

Radio control panel (optional)

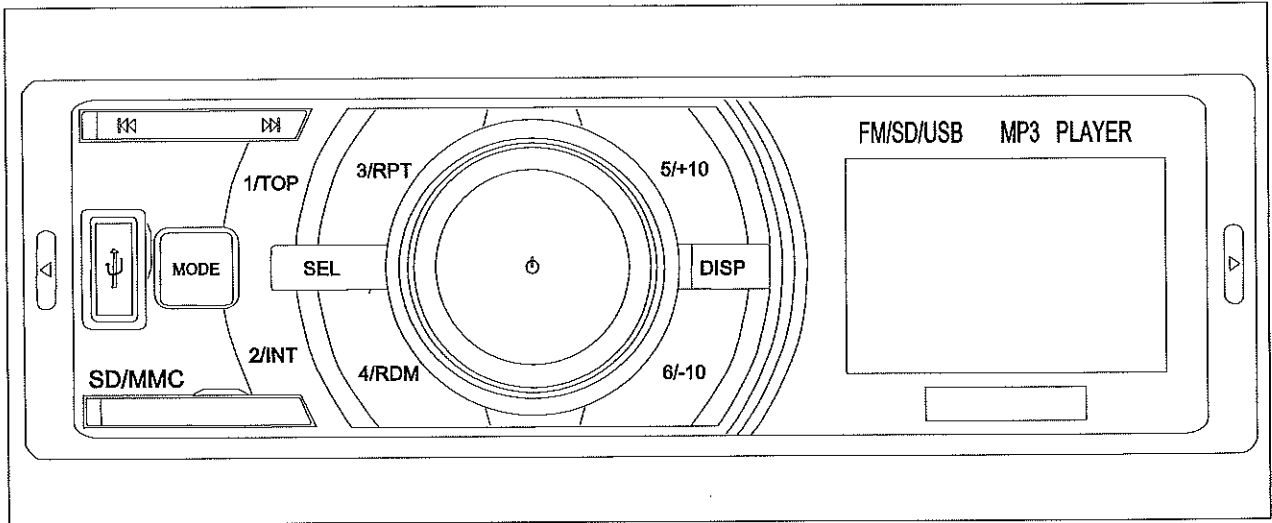

Fig.3-60

The radio is installed at the front of the cab.  
The Fig.3-60 shows the control panel.

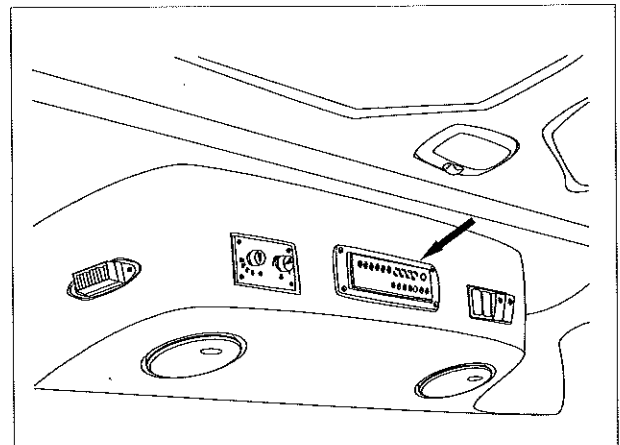



Fig.3-61

The functions of the control panel are shown in Table 3-1.

Table 3-1 Functions of keys on the radio panel

Keys	Status	Operation	Functions
VOL/PUSH POWER	FM/MP3	Short press	To turn on/off the radio.
		Rotation	To adjust volumn/balance/tune.
MODE	FM/MP3	Short press	To switch two modes.
	FM	Long press	To change wave bands.
SEL	FM/MP3	Short press	To choose VOL/BAS/TBR/BAL/FAL/ST.
DISP	FM/MP3	Short press	To display time.
		Time display	Long press
	FM	Short press	To shift one by one forward/backward
		Long press	To automatically search radio stations forward/backward
	MP3	Short press	To choose a song forward/backward
		Long press	Fast forward/reverse
	Time adjustment	Short press	To adjust the time values.
	1/TOP	MP3	Short press
FM		Short press	To load the frequency of Station 1.
		Long press	To save the current frequency as Station 1
2/INT	MP3	Short press	To turn on/off the browser and play function.
	FM	Short press	To load the frequency of Station 2.
		Long press	To save the current frequency as Station 2.
3/RPT	MP3	Short press	To turn on/off the Repeat One function.
	FM	Short press	To load the frequency of Station 3.
		Long press	To save the current frequency as Station 3.
4/RDM	MP3	Short press	To turn on/off the random play function.
	FM	Short press	To load the frequency of Station 4.
		Long press	To save the current frequency as Station 4.
5/+10	MP3	Short press	To skip over 10 songs forward.
	FM	Short press	To load the frequency of Station 5.
		Long press	To save the current frequency as Station 5.
6/-10	MP3	Short press	To skip over 10 songs backward.
	FM	Short press	To load the frequency of Station 6.
		Long press	To save the current frequency as Station 6.



### Windshield wiper/washer switch

In order to get a clearer visibility, the windshield can be washed by the washer and the front wiper system.

- Position (Up): The washer sprays water onto the front windshield and wipers.
- Position (Middle): No movement.
- Position (Down): The front wiper wipes the front windshield.

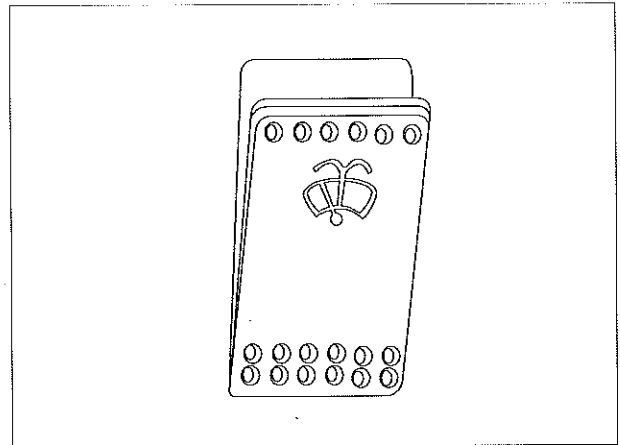

Fig.3-62

The figure shows the location of the windshield wiper and washer.

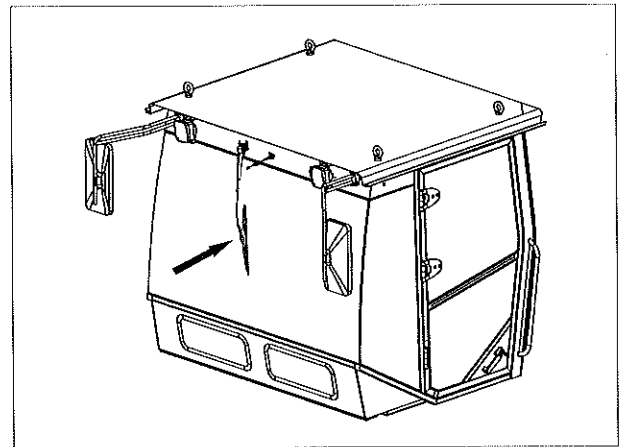

Fig.3-63

Every day before you operate the roller, you must check the water level of this water tank. Once the water level is less than the 2/3 of the water tank, it should be filled it up. Assure sufficient antifreeze agent content.

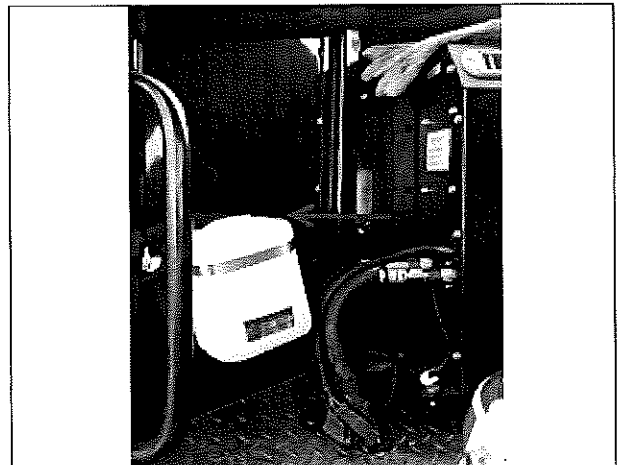

Fig.3-64



# SANY

## Operation

### 4 Operation

4.1 Check before Starting the Engine .....	4-1
4.1.1 Inspection (walk-around) .....	4-1
4.1.2 Inspection before Starting .....	4-2
4.1.2.1 Check the Engine Oil Level .....	4-2
4.1.2.2 Check the Engine Coolant Level .....	4-3
4.1.2.3 Check the Oil Water Separator .....	4-3
4.1.2.4 Check the Hydraulic Oil Level .....	4-4
4.1.2.5 Check the Washer .....	4-5
4.1.2.6 Check the Air Filter .....	4-5
4.1.2.7 Check the Water Tank .....	4-6
4.1.2.8 Check the Water Filter Element .....	4-6
4.1.2.9 Check the Tire Pressure .....	4-7
4.1.2.10 Check the Position of Limit Pin .....	4-7
4.1.2.11 Check the Vibratory Drum and Dampers .....	4-7
4.1.2.12 Check the Electric Wires .....	4-8
4.2 Adjustments Prior to Startup .....	4-8
4.2.1 Seat Adjustment .....	4-8
4.2.2 Rearview Mirror Adjustment .....	4-8
4.3 Equipments Checking Prior to Startup .....	4-9
4.3.1 Power on the Control System .....	4-9
4.3.2 Check the Fuel Level .....	4-10
4.3.3 Check the Propel Control Lever .....	4-11
4.3.4 Check the Emergency Stop Switch .....	4-12
4.3.5 Check the Parking Brake Switch .....	4-12

4.3.6 Check the Switches (If Any).....	4-12
4.4 Engine Starting.....	4-14
4.4.1 Normal Start.....	4-14
4.4.2 Jump-start.....	4-15
4.5 After Engine Starting.....	4-19
4.6 Test Running.....	4-20
4.7 Travel Operation.....	4-21
4.7.1 Travel forward.....	4-21
4.7.2 Travel reverse.....	4-22
4.7.3 Steering.....	4-22
4.7.4 Switching the Speed Gear.....	4-22
4.8 Vibration Operation.....	4-23
4.8.1 Vibration Mode and Switching.....	4-23
4.8.1.1 Manual Mode.....	4-23
4.8.1.2 Auto Mode.....	4-23
4.8.1.3 Switching the Vibration Mode.....	4-23
4.8.2 Vibration Frequency and Switching.....	4-24
4.8.2.1 High Frequency.....	4-24
4.8.2.2 Low Frequency.....	4-24
4.8.2.3 Switching the Vibration Frequency.....	4-24
4.8.2.4 Selecting Frequency according to the Road Condition.....	4-25
4.8.3 Vibration.....	4-25
4.8.3.1 Vibration in Manual Mode.....	4-25
4.8.3.2 Vibration in Auto Mode.....	4-27
4.9 Parking Operation.....	4-27
4.9.1 Service Brake.....	4-27
4.9.2 Parking brake.....	4-28
4.9.3 Emergency Brake.....	4-29
4.10 Crablike Travel Operation.....	4-30
4.11 Correct Operation for Water Spraying System.....	4-30
4.11.1 Manual Water Spraying Mode.....	4-32
4.11.2 Auto water spraying mode.....	4-32
4.12 Check after Each Work Day.....	4-33
4.13 Correct Driving According to the Road Condition.....	4-33
4.13.1 Working near Ditch Edge and Road Shoulder.....	4-33
4.13.2 Working near Buildings Vulnerable to Vibration.....	4-34
4.13.3 Working on the Slope.....	4-34

4.14 Other Auxiliary Equipments ..... 4-35

    4.14.1 Wiper ..... 4-35

    4.14.2 Radio Operation ..... 4-36

    4.14.3 Working Lights ..... 4-38

4.15 Transportation ..... 4-38

    4.15.1 Transport Vehicle ..... 4-38

    4.15.2 Using a Slope ..... 4-38

    4.15.3 Shipping ..... 4-40

        4.15.3.1 Container Shipping ..... 4-40

        4.15.3.2 Non-container Shipping ..... 4-44

**⚠ WARNING**

**Read and understand all safety precautions and instructions in this manual before reading any other manuals provided with this roller and before operating or servicing the roller. Failure to do this can cause property damage, personal injury or death.**

---

## 4 OPERATION

### 4.1 Check before Starting the Engine

#### 4.1.1 Inspection (walk-around)

Before starting the engine, it is necessary to inspect your roller carefully and completely. Check for any loose bolts or nuts. Check for any leaks of oil, fuel or coolant. Check the conditions of the hydraulic system. It is also necessary to check for loose wires, any spaces or dust buildup at where it is close to high temperature.

Remove flammable materials from the surrounding of battery, engine, muffler, turbocharger, or other hot components. The leak of oil or fuel may cause the machine to catch on fire. Careful inspection is necessary. Contact SANY distributor if any fault of your roller must be corrected.

Check and clean the following items each day before starting the engine.

- Check the motors, cylinders, hoses for cracks, excessive wear or loosening. Repair or replace it according to the fact.
- Remove the dirt and debris around the engine, battery and radiator. Check the surrounding of engine and radiator for buildup of dirt. Check the surrounding of muffler, turbo charger or other hot components for flammable materials like dry leaves and thin branches. Remove them if any dirt or flammable materials are found.
- Check for any leaks of coolant or oil around the engine. Repair it in case of any problem.
- Check the hydraulic unit, hydraulic tank, hoses and joints for any leaks of oil. Repair the leaks if any.
- Check the handrails and step for any problem like loose bolts. Repair it in case of any problem.

- Clean and check the rearview mirrors for any damage. Clean the mirrors and adjust their positions so that the area behind the roller could be seen clearly from operator's seat.
- Check the safety belt and holds for damage or wear. Replace it with a new one in case of any damage.

### 4.1.2 Inspection before starting

#### 4.1.2.1 Check the engine oil level

1. Take out oil dipstick (A) and wipe the oil off the dipstick with clean cloth.
2. Insert the dipstick to bottom and then pull it out.
3. Oil level should be between the MAX and MIN marks on dipstick. Add appointed engine oil (See Table 5-8 on page 5-12) through filler (B) if oil level is below the MIN mark.
4. If oil level is above MAX mark, open the screw plug close to the center articulation frame (1) to drain extra engine oil. Check oil level again.

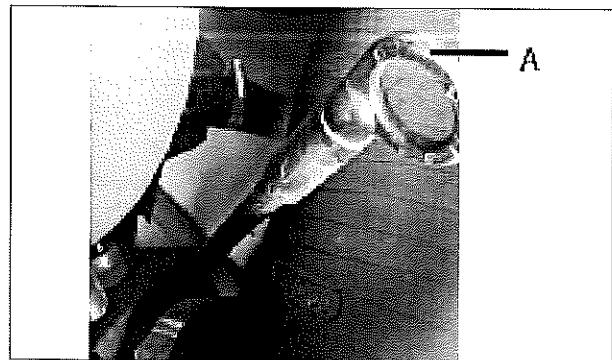

Fig.4-1

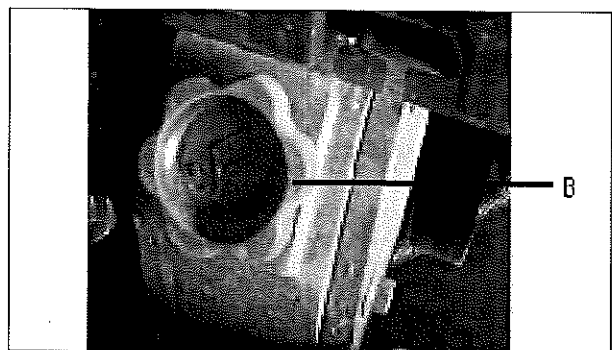

Fig.4-2

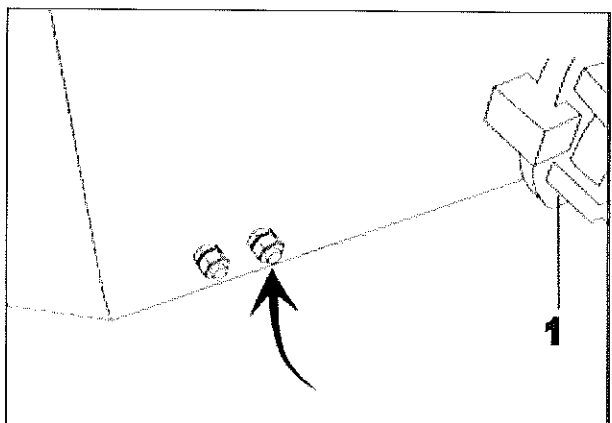

Fig.4-3

**⚠ CAUTION**

If the engine has been just shut down, the engine oil is still very hot. And you may be burned by the hot engine oil when draining the engine oil.



#### 4.1.2.2 Check the engine coolant level

### ⚠ CAUTION

If you try to start a roller that has been shut down, wait for the engine to cool down before you check the coolant level of the engine. Otherwise you may be burned by the spilling hot coolant. Before removing the cover, rotate the cover to release the pressure inside.

Add the coolant at the opening on the cover of the radiator. Generally, the level of the coolant is 15 millimeters below the inner top surface of the radiator. When coolant in radiator is not enough, fill it with the appointed coolant (See Table 5-8 on page 5-12) to the required level. Check the sealing of the water intake port and water outlet.

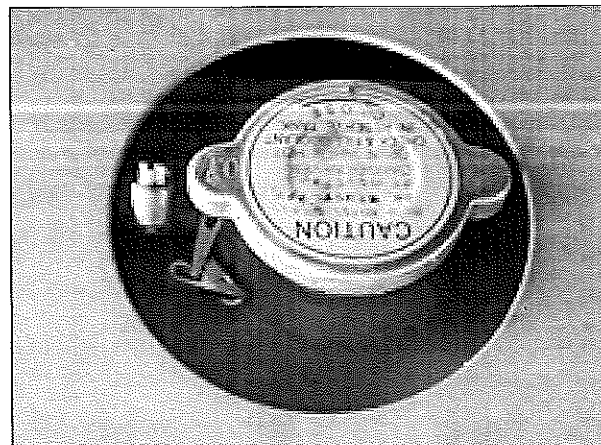

Fig.4-4

#### 4.1.2.3 Check the oil water separator

### ⚠ WARNING

**Fire hazard!** When working on the fuel system do not use open fire, do not smoke and do not spill any fuel. There is a possibility of catching fire.

1. Open the covering parts. The oil water separator (A) is on the left side of the roller.
2. Through transparent cover (B) you can observe water level and volume of sediment. In case of water or sediment built up at bottom, place a vessel under drain hoses to receive drainage.
3. Open drain valves (C) to discharge water.
4. When fuel is seen coming out of the drain hoses, close the drain valves (C) immediately.

Besides, check the hoses and pipe connector for loose to avoid the air going into the pipeline.

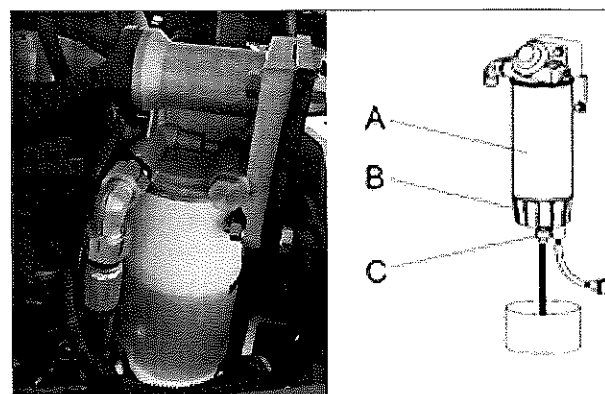

Fig.4-5

4.1.2.4 Check the hydraulic oil level

The hydraulic oil tank is welded on the left side of the rear frame. A level meter (A) is mounted on the hydraulic oil tank to show the level in the tank.

**⚠ CAUTION**

- Components and hydraulic oil are still hot after the engine has been just shut down. People working on them can easily get burned. Wait for them to cool down before working on them.
- When removing the lube filter for oil filling, turn it slowly to release internal pressure before removing it.

Normally, the level is about 2/3 of the level meter.

When the level is lower than the mark "L", take the following steps to fill the hydraulic tank. See Fig.4-7.

1. Clean the dust around the air filler (B).
2. Take off the air filter (B).
3. Fill the tank with appointed hydraulic oil (See Table 5-8 on page 5-12) through the oil filler.
4. When the level exceeds the 2/3 of the level meter, stop filling.

When the level is higher than the mark "H", take the following steps to drain the extra hydraulic oil.

1. Place a vessel under the oil outlet close to the center articulation frame.
2. Open the screw plug to drain the extra hydraulic oil.
3. When the level is about 2/3 of the level meter, stop draining.

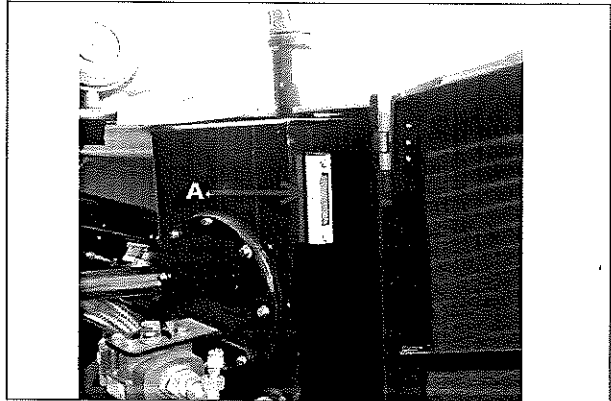

Fig.4-6

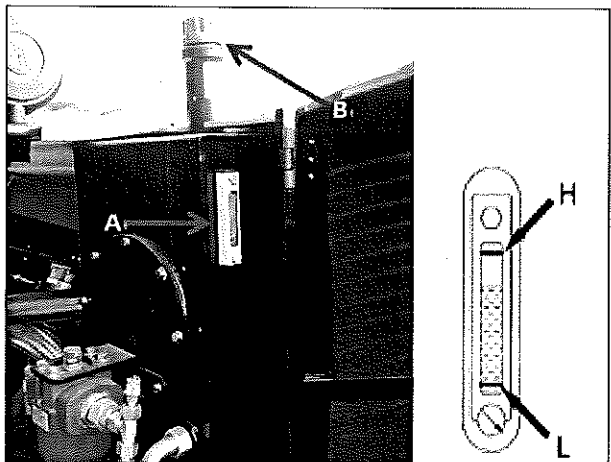

Fig.4-7

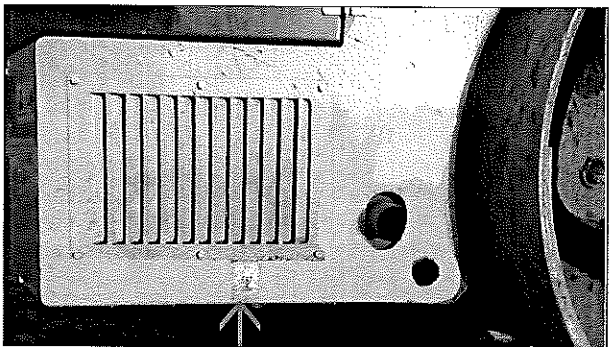

Fig.4-8

**NOTE:** The oil level will change after startup of engine, check the level again before working.

**NOTE:** The oil level may change as the oil temperature varies. While in operation, keep the oil level about 2/3 of the level meter.

#### 4.1.2.5 Check the washer

The container of washer is mounted inside the rear frame. If the water level is below 2/3, add water fully.



Fig.4-9

#### 4.1.2.6 Check the air filter

Take the following steps to remove the accumulated dust.

1. Open the covering part, and then the air filter can be seen.
2. Empty dust by pressing the dust evacuator.
3. Close the access door.

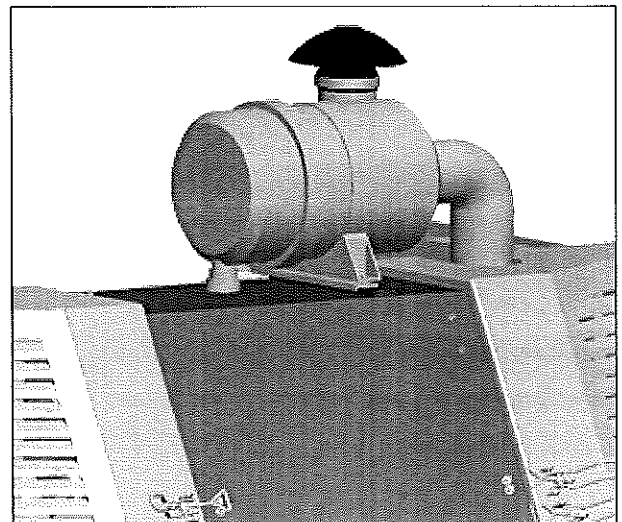

Fig.4-10

**4.1.2.7 Check the water tank**

Check water level in the water tank. If water is insufficient, take off the cover of the water tank, and refill the tank fully through the screen.

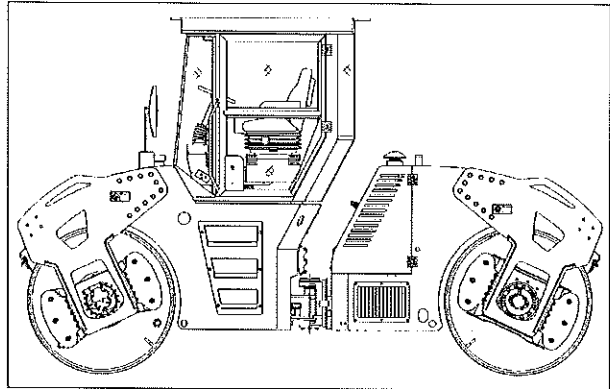

Fig.4-11

**4.1.2.8 Check the water filter element**

Before work, first open the access doors for water pumps on the front and rear frames. Rotate the plastic caps of the filters slowly, remove them towards the vertical direction, drain water in pipes and clean the filter elements.

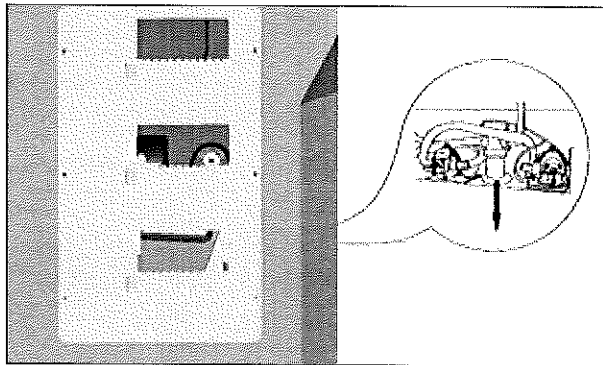

Fig.4-12

**NOTICE**

**When you are removing the plastic caps of the water filter, be careful to avoid water into the electrical elements close to water pumps, or it will cause circuit short.**

**4.1.2.9 Check the tire pressure**

Check the tire pressure with a pressure gauge. The range of tire pressure should be  $1.4 \pm 0.3$  kgf/cm<sup>2</sup>. When the tire pressure is lower, you have to charge the tires.

**NOTICE**

The tire pressure will increase if the tire is exposed to the sun. Too much charging will cause the tire to blow.

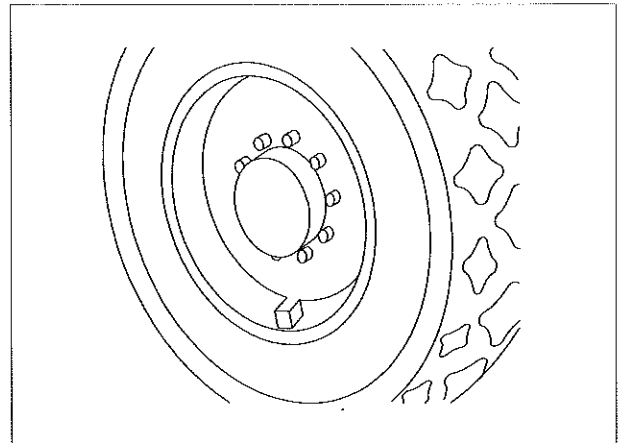

Fig.4-13

**4.1.2.10 Check the position of limit pin**

Make sure the limit plate for front and rear frames is unlocked. Then the roller can steer.

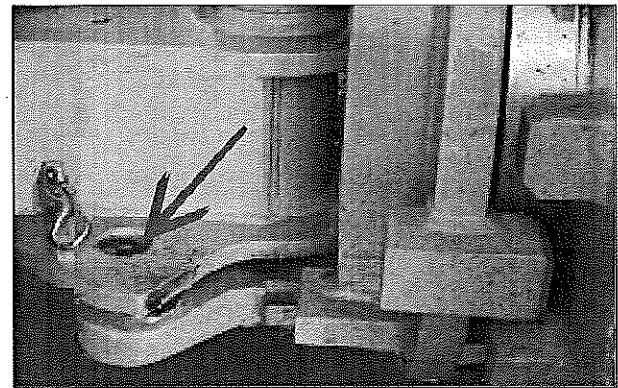

Fig.4-14

**4.1.2.11 Check the vibratory drum and dampers**

Check the connection of the hydraulic pipeline on motor and reducer, and make sure that they are in good condition. Check the dampers for big cracks.

**NOTICE**

Make sure that there is no big crack (should be less than 15 millimeters) on the dampers (shown in Fig.4-15), and the connecting bolts and nuts are connected firmly. If not, the traveling function will be influenced. Replace the worn dampers.

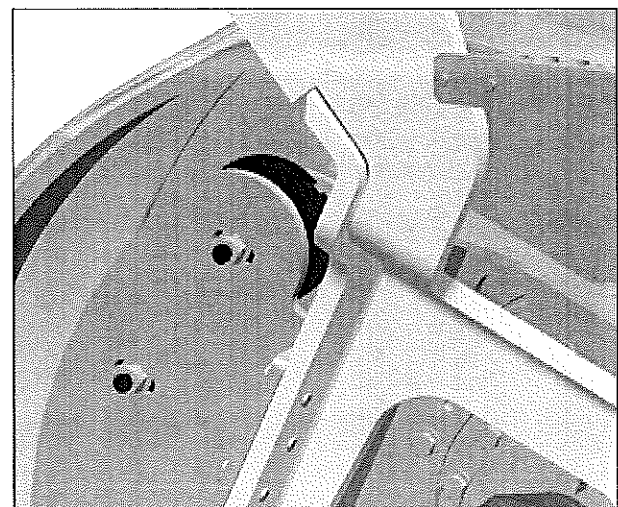

Fig.4-15

4.1.2.12 Check the electric wires

**NOTICE**

If any fuse burns frequently or any wire shows the sign of short circuit, contact SANY distributor to find the cause and eliminate the trouble. If not, this will affect the control system chronically.

Check whether the fuse is damaged; whether the fuse with proper capacity is used; whether any wire connection is off; whether wire sheath is broken. Check for loose terminals. Fix it if any. Moreover, pay special attention to electric wires when checking battery, engine, start motor and alternator. Make sure to check for flammable materials around battery. Immediately remove them if any.

**4.2 Adjustments Prior to Startup**

**4.2.1 Seat adjustment**

Before operation, the operator should adjust the seat to get the best comfortable position. And this will help to alleviate the fatigue. All the adjustments can be done only when the operator is seated.

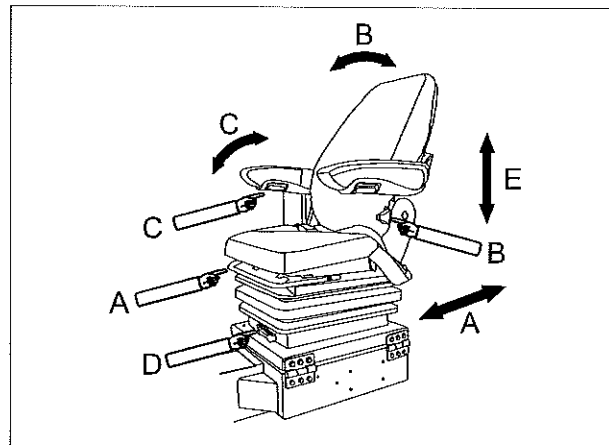

Fig.4-16

**4.2.2 Rearview mirror adjustment**

Adjust the angle of rearview mirror so that the operator can see the rear situations clearly.

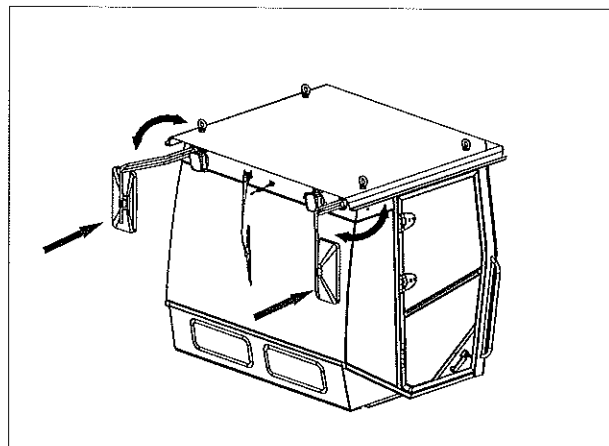

Fig.4-17

### 4.3 Equipments Checking Prior to Startup

Before starting up the engine, you need to check some equipments to see whether they are in good condition or not.

#### 4.3.1 Power on the control system

Before checking the equipment, you have to power on the control system first.

1. Connect the master disconnect switch of power supply.

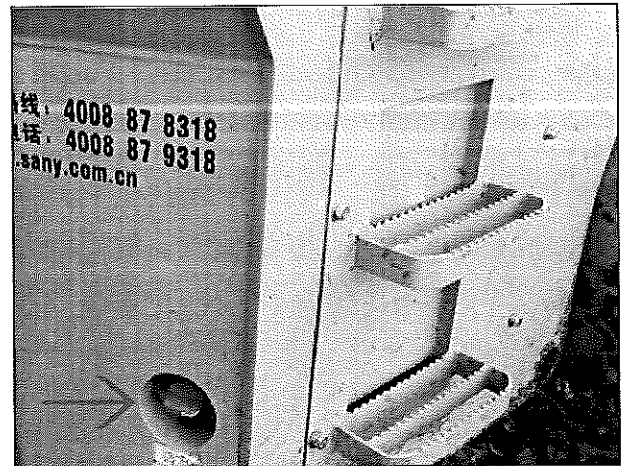

Fig.4-18

2. Insert the key, and turn to the "I" position. So the control system will be powered on. And the SYLD will be initialized.

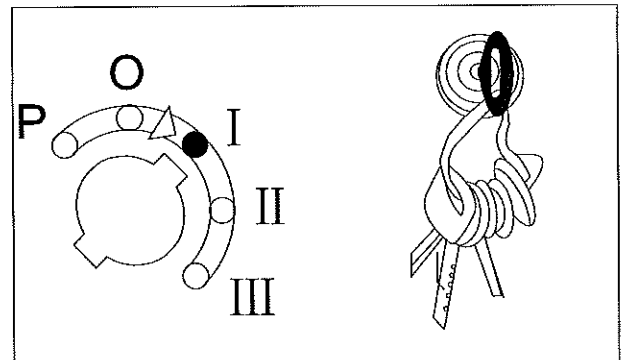

Fig.4-19

- After initialization, SYLD will show the current situation of the system.

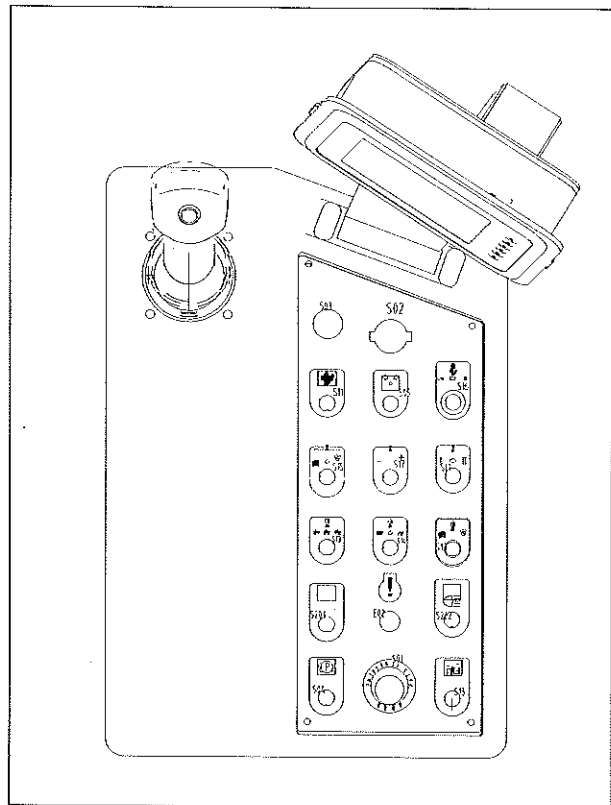

Fig.4-20

At this moment, if the parking brake indicator, the NEUTRAL position indicator, the battery charging indicator and engine oil pressure indicator light up, while other indicators are off. This indicates the circuit is ready.

#### 4.3.2 Check the fuel level

If fuel level indicator flashes yellow, it means the fuel is going to use up. You have to fill the fuel tank with the appropriate fuel (See Table 5-8 on page 5-12).

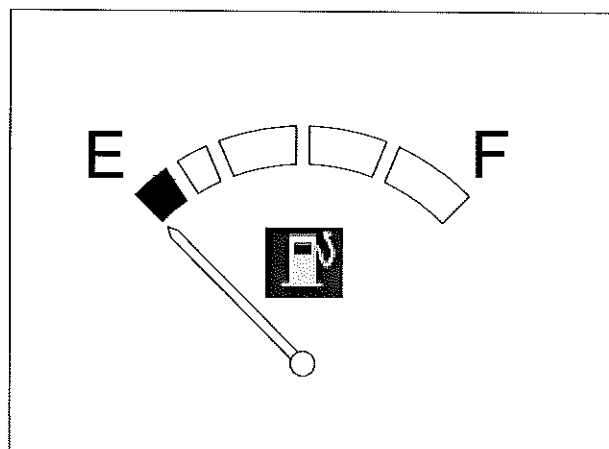

Fig.4-21



Take the following steps to fill the fuel tank.

1. Clean the dust around the filler.
2. Open the cover of fuel tank, and fill the fuel tank with appointed fuel (See Table 5-8 on page 5-12) through the filter net.

### **⚠ WARNING**

**When operating on the fuel tank, pay great attention to the fuel. There is a great potential to catch fire!**

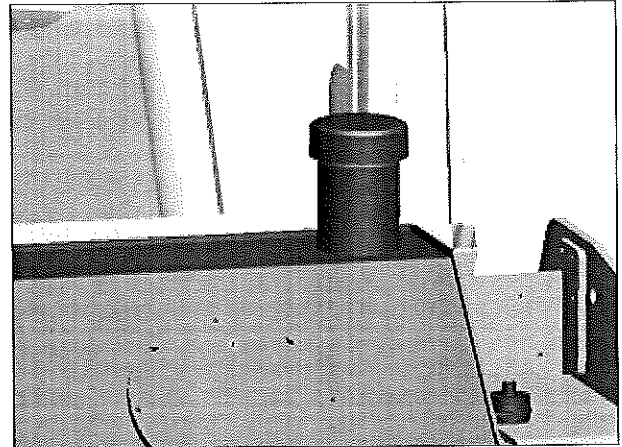

Fig.4-22

3. While the fuel level pointer leaves the "E" area, the fuel level alarm indicator icon goes out. When the fuel level pointer gets the point that you want, stop filling.
4. Close the cover of fuel tank.

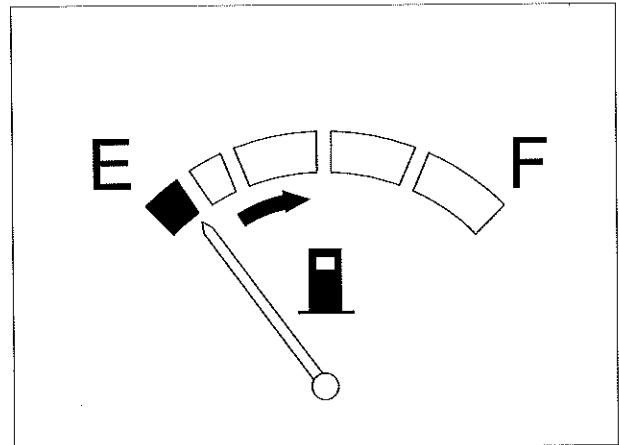

Fig.4-23

#### **4.3.3 Check the propel control lever**

Before starting the engine, the propel control lever should be placed at STOP position, or else the roller will suddenly run when engine is started. And the impact will cause not only danger to the operator, but also harm to engine and pump.

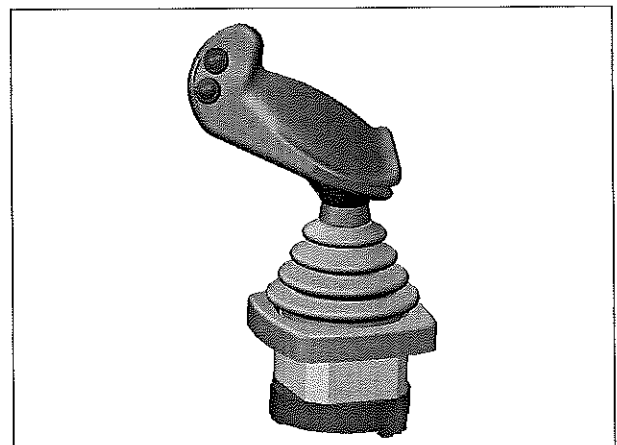

Fig.4-24

**4.3.4 Check the emergency stop switch**

Before starting the engine, the emergency stop switch should be released, or else the engine can not be started.

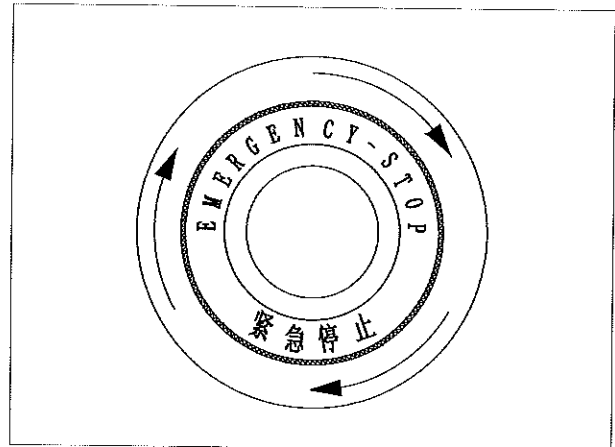

Fig.4-25

**4.3.5 Check the parking brake switch**

Before starting the engine, check the parking brake switch. Make sure that it is rotated to the "0" position.

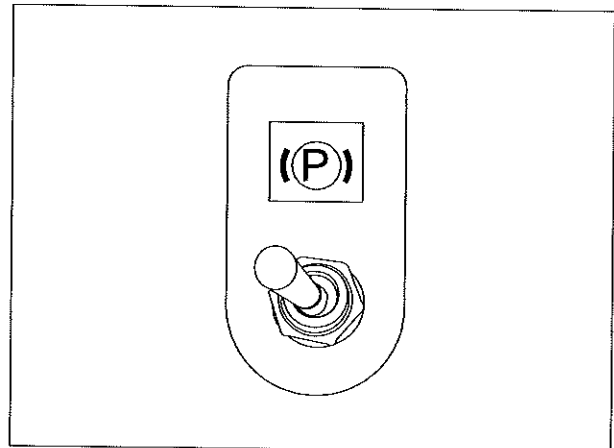

Fig.4-26

**4.3.6 Check the switches (if any)**

Before starting the engine, check the switches, indicators and working device to see whether they are in control or not. Fix if any problem appears.

- The turning light switch.

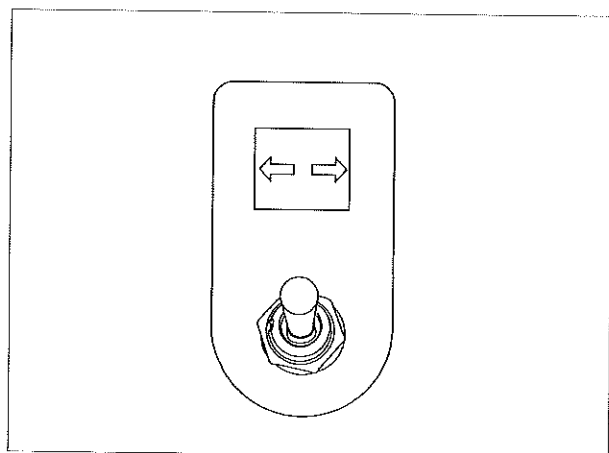

Fig.4-27

- The front/back working light switch.

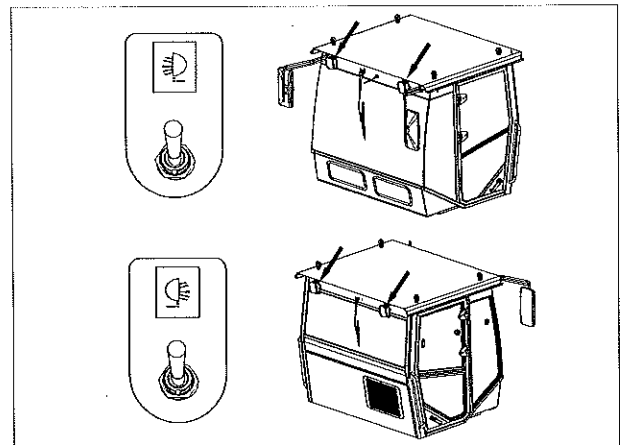

Fig.4-28

- Crablike travel control switch.  
Ensure the switch is at NEUTRAL position before the engine starts.

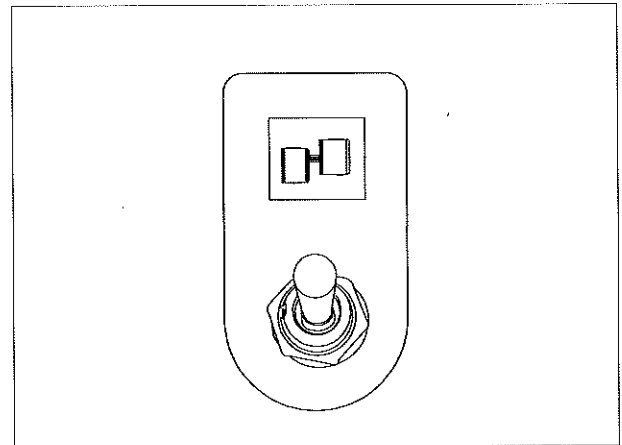

Fig.4-29

- The horn.

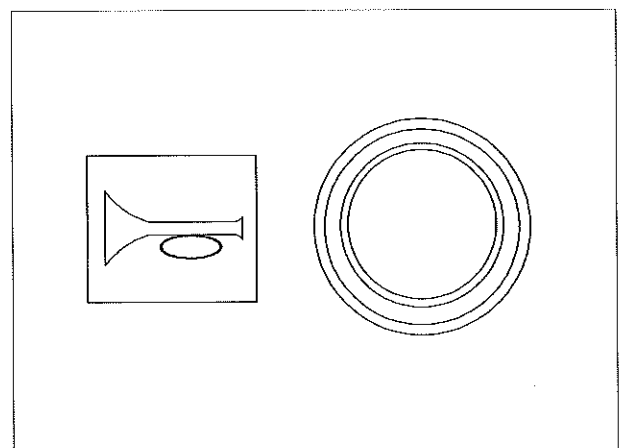

Fig.4-30

- The windshield washer and front wiper.

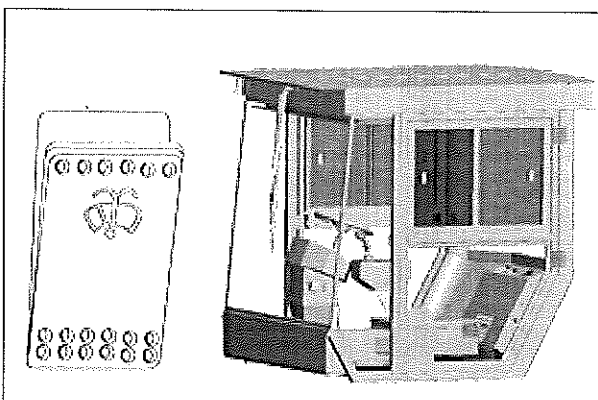

Fig.4-31

- The rear wiper (optional).

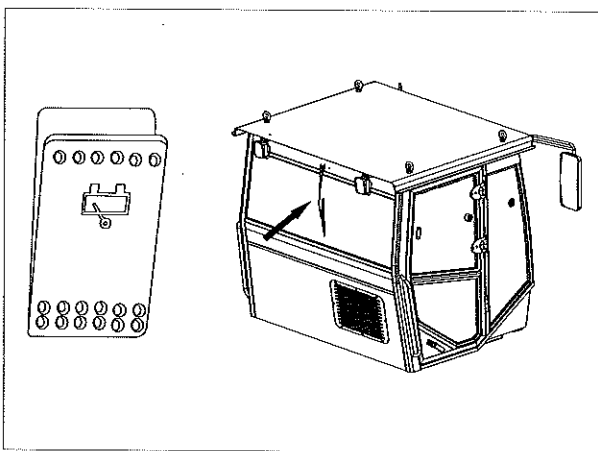

Fig.4-32

## 4.4 Engine Starting

After checking the items above and eliminating malfunction, you can start up the engine.

### 4.4.1 Normal start

1. Turn the key to the "III" position.
2. Hold the key at the "III" position.
3. Release the key immediately after the engine is started. The key will return to the "I" position automatically.

### NOTICE

Each starting time shall not exceed 10s and the interval shall be no less than 5min. If it cannot be started after 3 attempts continuously, stop starting and find out the cause, or it will shorten the service life of the engine.

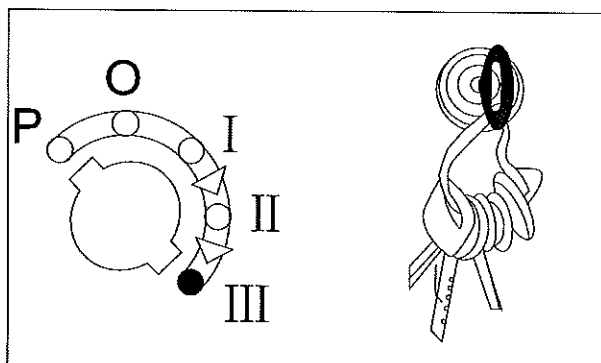

Fig.4-33

#### 4.4.2 Jump-start

### **⚠ WARNING**

Never short across the starter terminals! Shorting across the starter terminals could damage the electrical system, and result in unexpected machine motion or behavior. This could cause personal injury or death.

### **⚠ WARNING**

- Properly service the batteries, otherwise it may cause personal injury.
- Prevent sparks near the batteries. They could cause vapors to explode. Do not allow the jump start cable ends to contact each other or the machine.
- Electrolyte is an acid, which can cause personal injury if it contacts the skin or eyes.
- Always wear goggles and rubber gloves when starting a machine with jump start cables.
- Improper jump start procedures can cause an explosion, resulting in personal injury.
- When using jumper cables, always connect the positive (+) jumper cable to the positive (+) battery terminal first. Next, connect the negative (-) jumper cable to the frame away from the batteries.
- Jump start only with an energy source of the same voltage as the stalled machine.
- Turn off all lights and accessories on the stalled machine. Otherwise, they will operate when the energy source is connected.

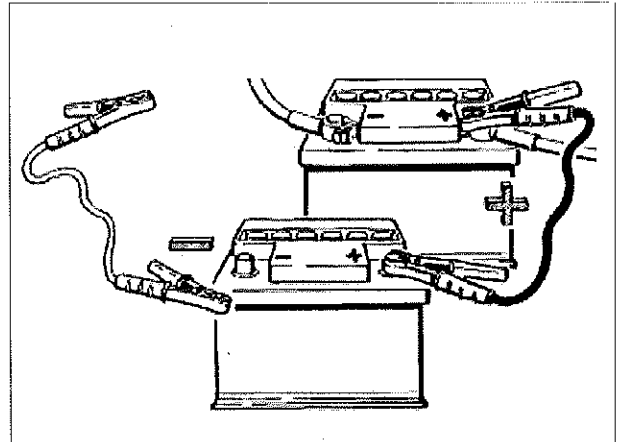

Fig.4-34

**NOTICE**

- **Ensure that the machine that is used as an electrical source does not touch the stalled machine. This could prevent damage to engine bearings and electrical circuits.**
- **Turn on the disconnect switch on the electrical source. This will help to prevent damage to electrical components on the stalled machine.**
- **This machine has a 24 voltage starting system. Use only equal voltage for jump start. Use of a higher voltage will damage the electrical system.**

If the batteries are short of energy, you can start up the engine according to the steps as follows.

**NOTE:** Using jumper cable to start engine requires two persons working together (One is seated in the operator's seat and the other handles the battery).

1. On the stalled machine, place the propel control level in the NEUTRAL position. Engage the park brake on the stalled machine. Lower the equipment to the ground.
2. Turn the engine start switch on the stalled machine to the OFF position. Turn off all accessories.
3. Turn the battery disconnect switch on the stalled machine to the ON position.
4. Move the machine that is being used as an electrical source near the stalled machine so that the jump start cables reach the stalled machine. Do not allow the machines to contact each other.
5. Stop the engine of the machine that is being used as an electrical source. If you are using an auxiliary power source, turn off the charging system.

6. Ensure that battery caps on both machines are tight and correctly placed. Ensure that batteries in the stalled machine are not frozen.
7. The positive ends of the jump start cable are red. Connect one positive end of the jump start cable battery.
8. Connect the other positive end of the jump start cable to the positive cable terminal of the electrical source.
9. Connect one negative end of the jump start cable to the negative cable terminal of the electrical source.
10. Finally, connect the other negative end of the jump start cable to the frame of the stalled machine. Do not connect the jump start cables to contact the battery cables, the fuel lines, the hydraulic lines, or and moving parts.
11. Start the engine of the machine that is being used as an electrical source or energize the charging system on the auxiliary power source.
12. Wait at least two minutes before you attempt to start the stalled machine. This will allow the batteries in the stalled machine to partially charge.
13. Attempt to start the stalled engine. **See: section 4.4.1 Normal start on page 4-14.**
14. Immediately after you start the stalled engine, disconnect the jump start cables in reverse order.

**NOTE:** The batteries for SANY single drum roller are composed of two serial maintenance-free battery. The total voltage is 24V.

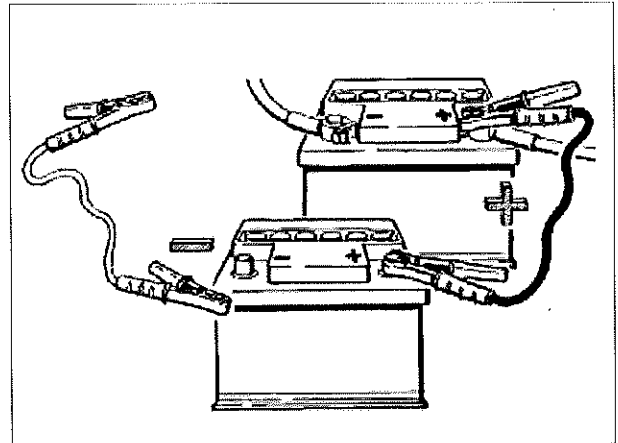

Fig.4-35

### 4.5 After Engine Starting

After starting the engine, the roller shouldn't be used to work at once. There should be 3-5 minutes for the engine to run in idling speed.

Turn the throttle control knob to the LOW position, then the engine will run in idle speed.

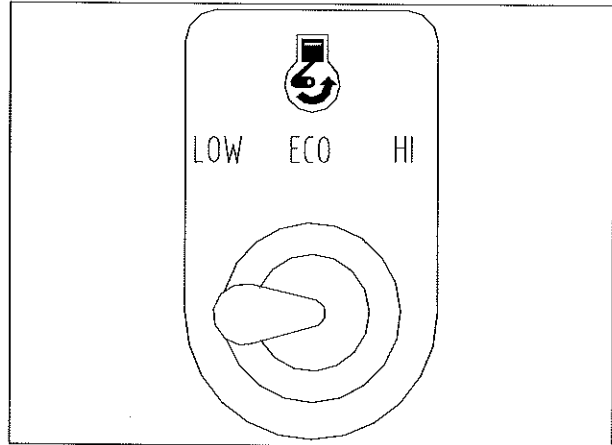

Fig.4-39

Observe the pressure gauges, instruments and warning lights to ensure they are properly functioning, with all readings within specific ranges.

**NOTE:**

After the engine is started up, generally the hydraulic oil level will be lower. If the hydraulic oil level is lower than 1/2 of the range, stop the roller. Wait for the engine cooling down, and then fill the hydraulic oil tank to the recommended mark (**See: section 4.1.2.4 "Check the hydraulic oil level" on page 4-4**).

If everything is ok, turn the throttle control knob to the HI position.

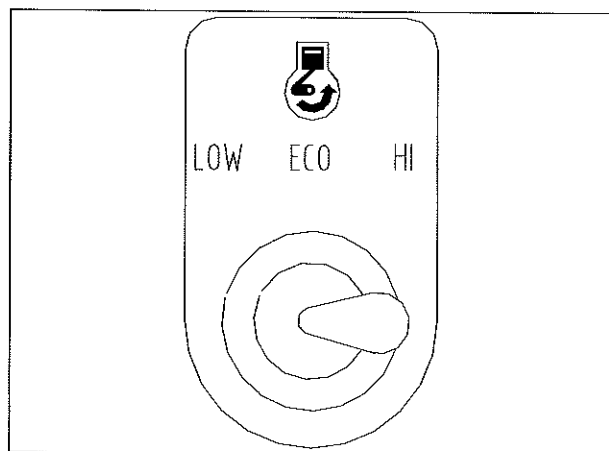

Fig.4-40

If any problem appears, rotate the key to the P/O position to stop the engine. Check out and eliminate the fault.



## 4.6 Test Running

If all the checking items above are qualified for working, you can drive the roller to make some simple movements such as moving forward slowly, making a turning for testing.

Before testing, there are some default settings for the roller.

- Speed gear: Select low speed.

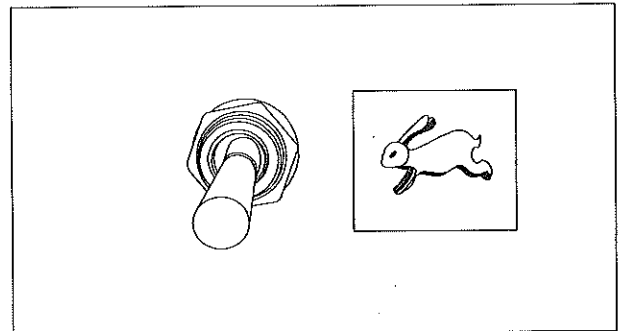

Fig.4-41

- Vibration mode: Select the "O" position.

**NOTE:** When the vibration mode is set at "O" position, the roller won't vibrate.

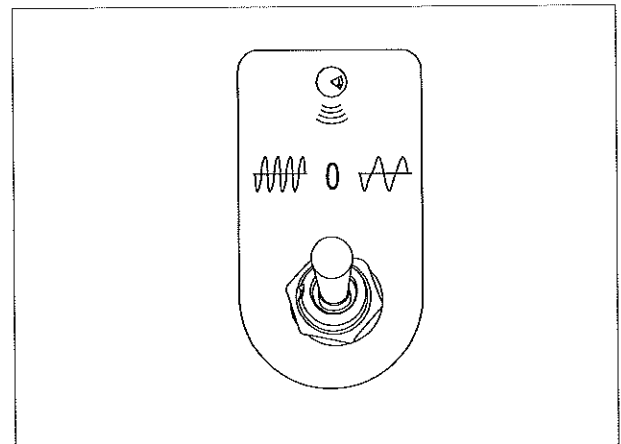

Fig.4-42

If there is any problem such as abnormal noise, vibration, smell, smoke, stop the engine and check faults out. If everything is ok, the roller can be applied to work.

## 4.7 Travel Operation

### 4.7.1 Travel forward

Take the following steps to travel forward.

1. Select speed gear according to the road condition.

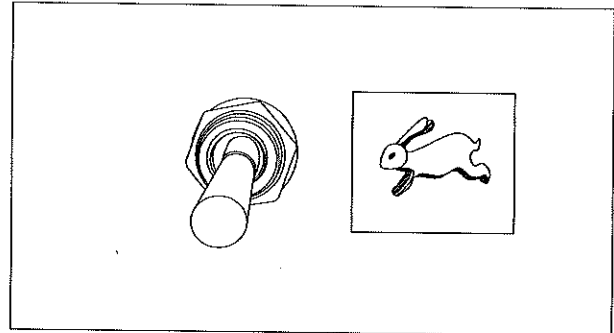

Fig.4-43

2. Select vibration mode: the "O" Position. See Fig.4-44.

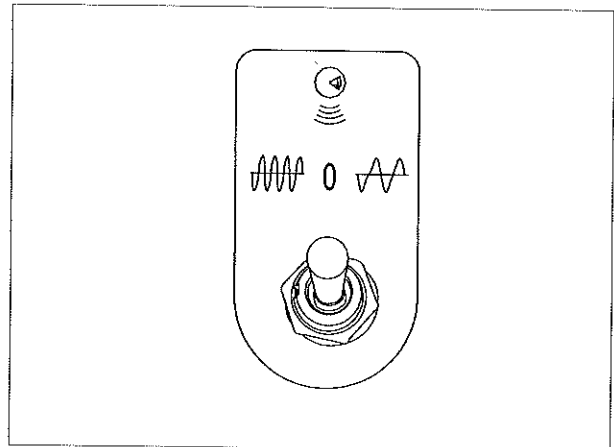

Fig.4-44

3. Push the propel control lever forward from the mid-position.

### **⚠ CAUTION**

**It's forbidden to push/pull the propel control lever without holding the steering wheel, or this will lose direction control of the roller and may cause accidents.**

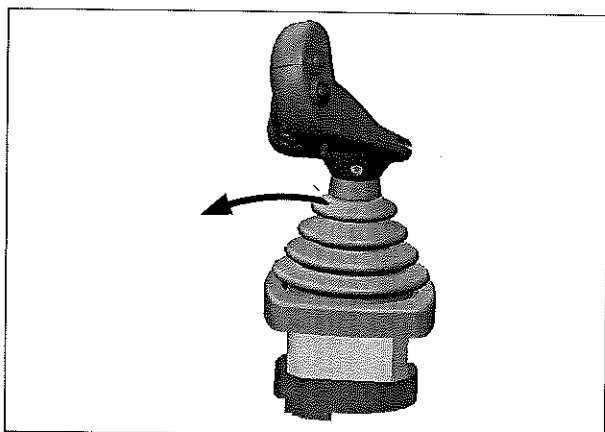

Fig.4-45

### 4.7.2 Travel reverse

Make the same settings as traveling forward. Then pull the propel control lever from the mid-position.

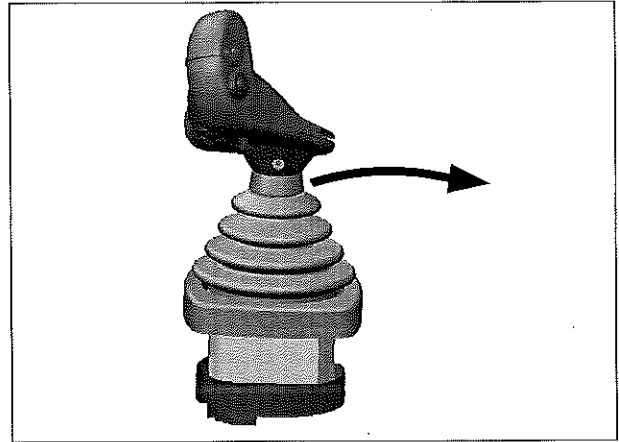

Fig.4-46

### 4.7.3 Steering

Take turning left forward for example.

1. Make the same settings as traveling forward.
2. Turn on left turn flashes lights. (See callout 2 in Fig.3-2 on page 3-2)
3. Push the propel control lever from the mid-position, mean while rotate the steering wheel to the left.

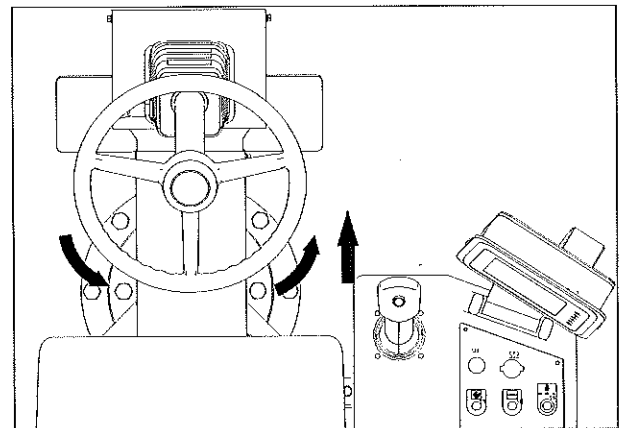

Fig.4-47

### 4.7.4 Switching the speed gear

When the roller is traveling, you have to make service brake before switching. How to service brake. See: section 4.9.1 "Service brake" on page 4-27.

## NOTICE

It is forbidden to switch the speed gear directly. Otherwise it may cause significant impact to the hydraulic system.

## 4.8 Vibration Operation

### 4.8.1 Vibration mode and switching

#### 4.8.1.1 Manual mode

Rotate the vibration mode selection switch to the "2" position when the roller is not in vibration. At this moment, the start of vibration is controlled by the vibration button.

### NOTICE

**Don't press down the vibration button while the roller is stationary. It will cause harm to the bearings.**

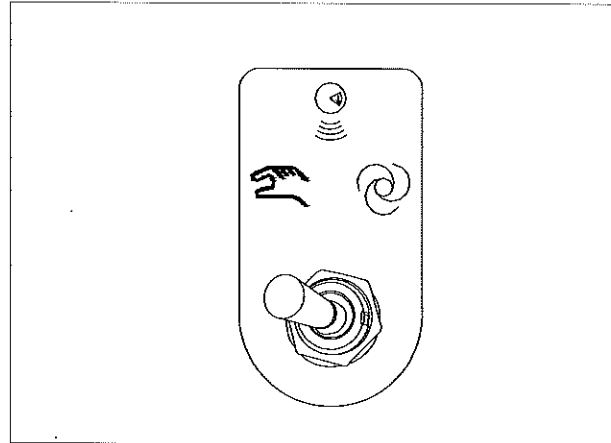

Fig.4-48

#### 4.8.1.2 Auto mode

Rotate the vibration mode selection switch to position "3" when the roller is not in vibration. At this moment, the start of vibration is controlled by traveling speed.

When traveling speed surpasses 1.5km/h, the roller starts vibration automatically; when traveling speed is lower than 1.5km/h, vibration is stopped.

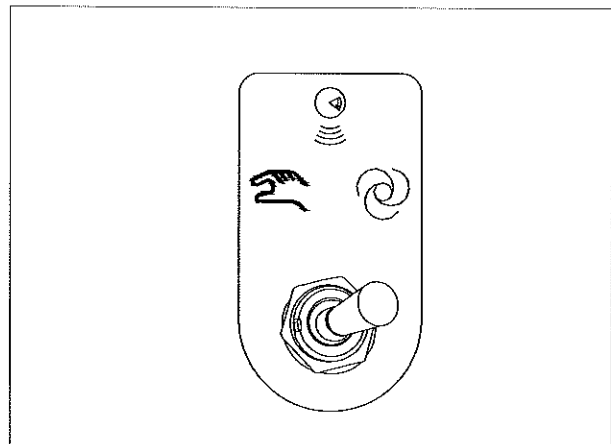

Fig.4-49

#### 4.8.1.3 Switching the vibration mode

Before switching the vibration mode, stop vibration first.

In MANUAL mode, press the vibration button for the second time. Then the vibration button will bounce and vibration stops.

In AUTO mode, move the propel control lever to the STOP position slowly. When the speed is lower than 1.5km/h, vibration stops automatically.

## 4.8.2 Vibration frequency and switching

### 4.8.2.1 High frequency

Rotate the vibration frequency selection switch to the left position when the roller is not in vibration. Then the vibration will be set as high frequency, small amplitude and small vibration force is acquired.

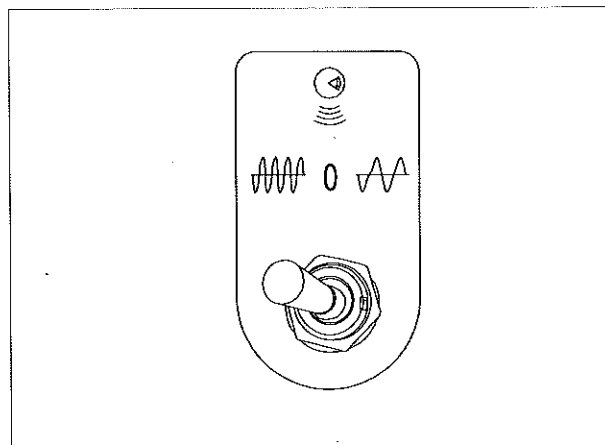

Fig.4-50

### 4.8.2.2 Low frequency

Rotate the vibration frequency selection switch to the right position when the roller is not in vibration. Then the vibration will be set as low frequency, large amplitude and large vibration force is acquired.

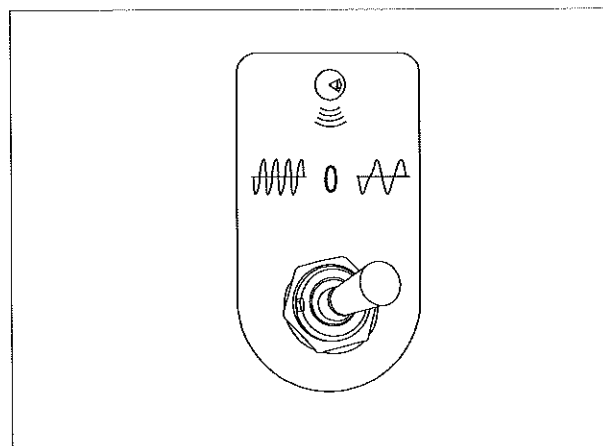

Fig.4-51

### 4.8.2.3 Switching the vibration frequency

#### NOTICE

**Before switching the vibration frequency, stop vibration first. Otherwise it may cause significant impact to the hydraulic system.**

**4.8.2.4 Selecting frequency according to the road condition**

The drum roller is often used to compact the foundations of the road. Different vibration frequency is chosen according to the working procedure. Generally, the working procedure could be static rolling, high-frequency rolling, low-frequency rolling and a final static rolling.

**4.8.3 Vibration**

**4.8.3.1 Vibration in manual mode**

Take the following steps to vibrate in MANUAL mode.

1. Choose the MANUAL mode.

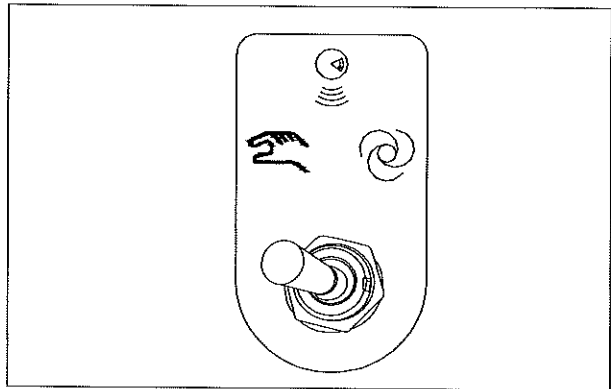

Fig.4-52

2. Choose low speed gear.

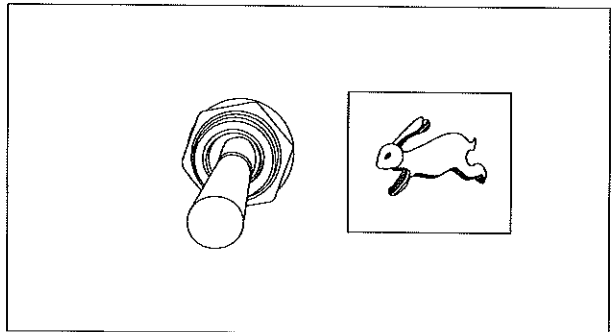

Fig.4-53

3. Choose vibration mode according to the working requirements.

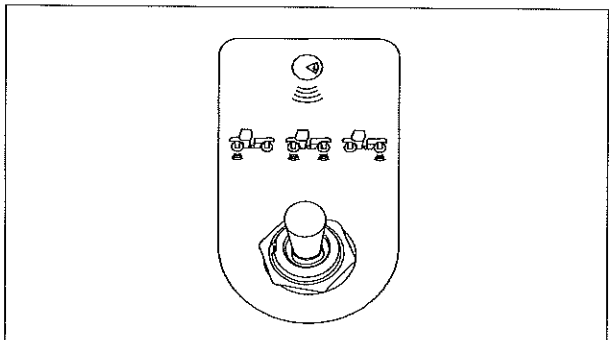

Fig.4-54

5. Choose vibration frequency according to the working requirements.

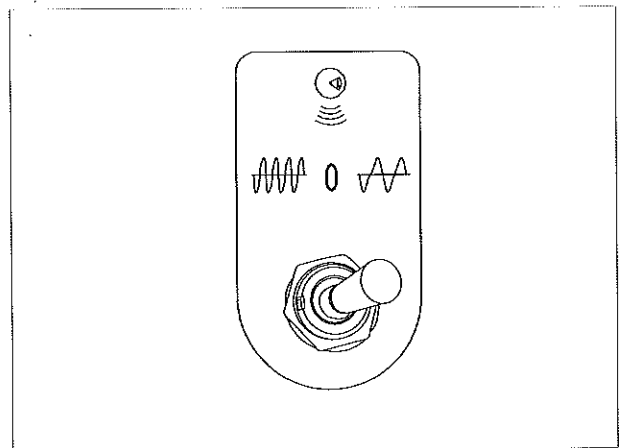

Fig.4-55

6. Push the propel control lever forward slowly to speed up the roller.

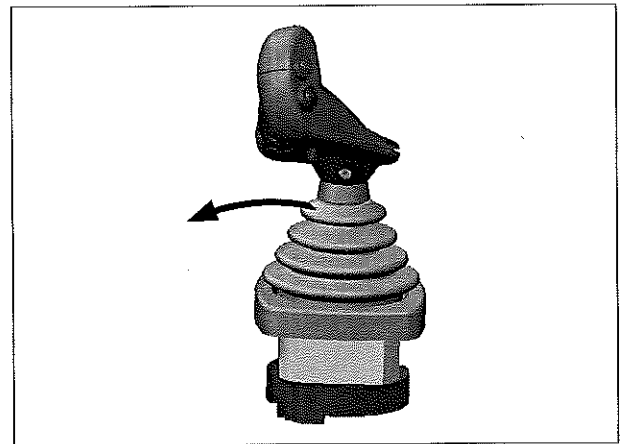

Fig.4-56

7. Press down the red vibration button to vibrate.

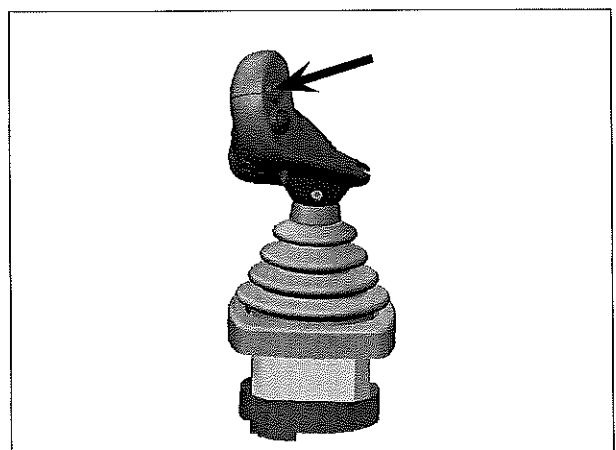

Fig.4-57

8. After work, press down the vibration button again to stop vibration.

#### 4.8.3.2 Vibration in auto mode

Take the following steps to vibrate in Auto mode.

1. Select AUTO mode.

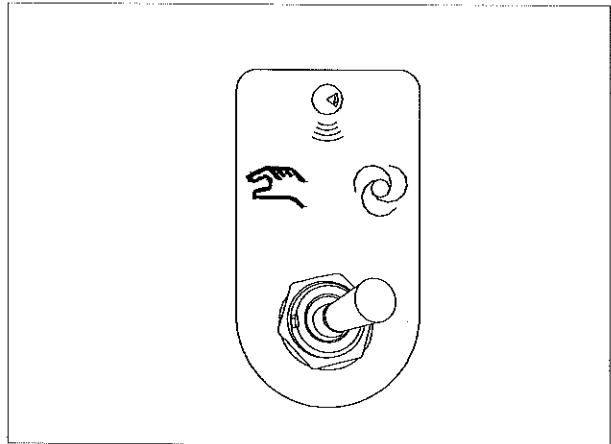

Fig.4-58

2. Select the low speed gear, and vibration frequency according to the working requirements.
3. Speed up the roller forward. When traveling speed surpasses 1.5km/h, the roller will vibrate automatically.

**NOTE:** During working, the traveling speed must be held. Once the traveling speed is lower than 1.5km/h, the roller will stop vibrate automatically.

4. After work, pull the propel control lever to the STOP position, and vibration will be stopped.

## 4.9 Parking Operation

### 4.9.1 Service brake

Service brake is used to stop the roller but not the engine. Service brake should be carried out before switching speed gears. Take the following steps to do service brake.

1. If the roller is vibrating, stop vibration first. If the vibration mode is manual, press the vibration button. In auto mode, the roller will stop vibrating when speed slow down to 1.5km/h automatically.



2. Move the propel control lever slowly to the STOP position.

#### 4.9.2 Parking brake

Parking brake is used to stop the roller completely. After everyday's work, parking brake will be carried out. Take the following steps to do parking brake.

1. Select an applicable place for parking. Usually a flat ground is recommended.
2. Do service brake as it is shown above.
3. Rotate the parking brake switch to the P position.

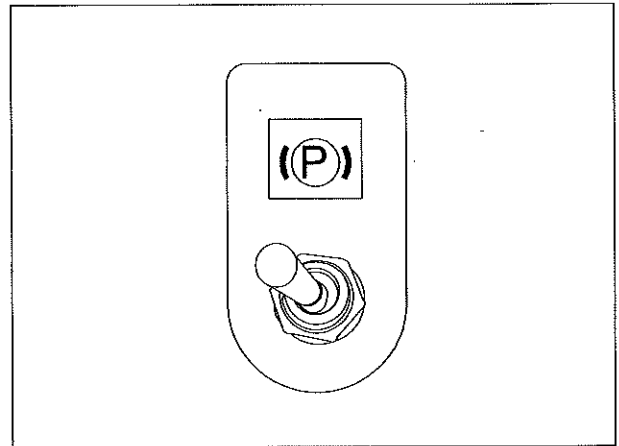

Fig.4-59

4. Turn the throttle control knob to the LOW position for idling the engine for 3-5 minutes.

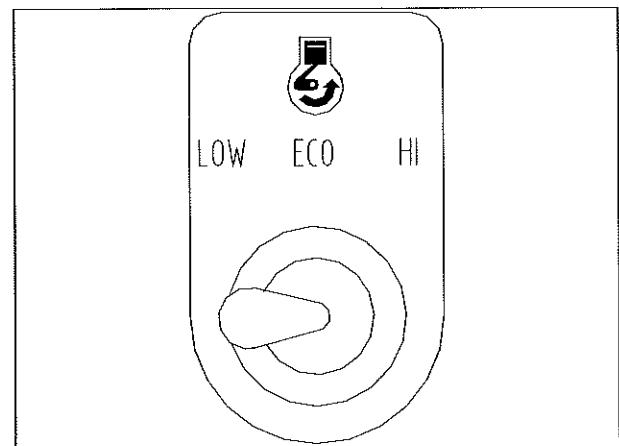

Fig.4-60

- After 3-5 minutes' idle warm-up, rotate the key to the P/O position ,and take off the key.

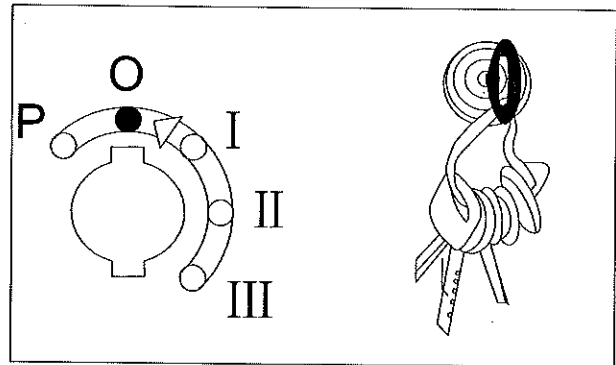

Fig.4-61

- Turn off the master disconnect switch of power supply.

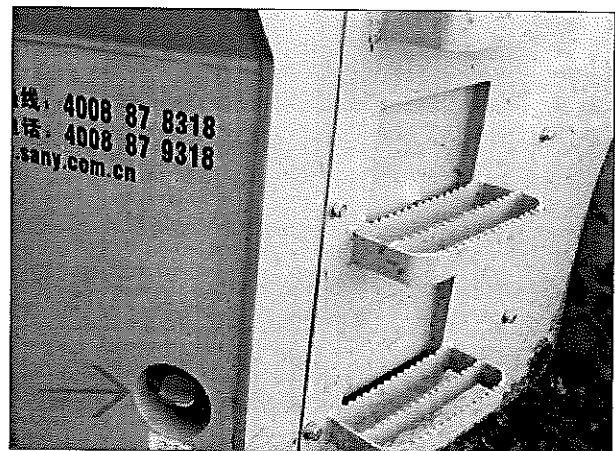

Fig.4-62

- Lock the cabin's door.

### 4.9.3 Emergency brake

The emergency brake is used to stop the roller immediately, and the engine will be shutdown too. Whenever come across a dangerous situation, press down the emergency stop switch at once.

#### NOTICE

**The emergency stop switch must not be used as a service brake. Or else it will reduce the engine's performance and service life.**

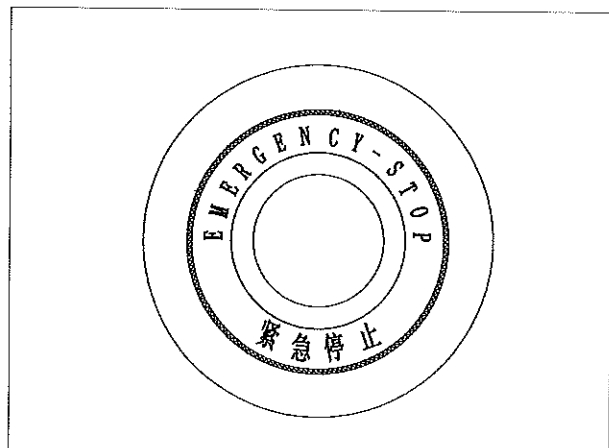

Fig.4-63

## 4.10 Crablike Travel Operation

Crablike travel is realized by misaligning the front frame with the rear frame for a certain distance leftward or rightward through crablike traveling cylinder. It is a kind of operation used to increase compacting area. Crablike travel is used for road edge compacting to ensure the road shoulder compaction result.

Crablike travel is controlled by crablike travel control switch on the panel.

- Turn the switch to the left side, and the roller carries out crablike travel leftward;
- Turn the switch to the right side, and the roller carries out crablike travel rightward;
- Turn the switch to the middle position, and the roller stops crablike travel.

**NOTE:** Only carry out crablike travel operation at a low speed. Or the roller may depart from the compaction track.

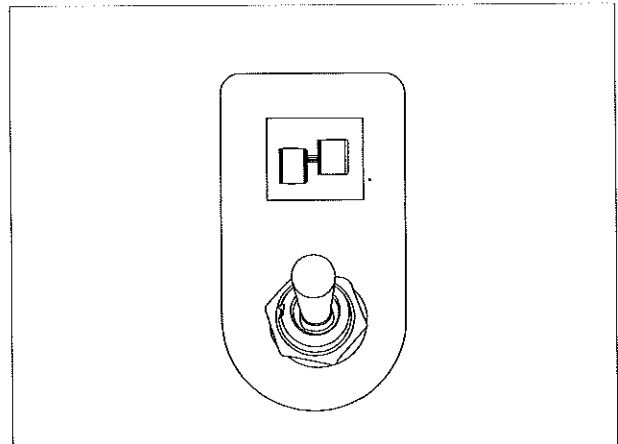

Fig.4-64

## 4.11 Correct Operation for Water Spraying System

During the roller is working on the job site, synchronous water spraying is needed. Confirm the following items prior to put water spraying into work:

- If the water level indication on SYLD shows insufficient water in the water tank, add water immediately.

**NOTE:** If the water is not filled timely, air into the pipes causes water spraying fault. At this time, open the ball valve to exhaust air. After that, water spraying function can be available.

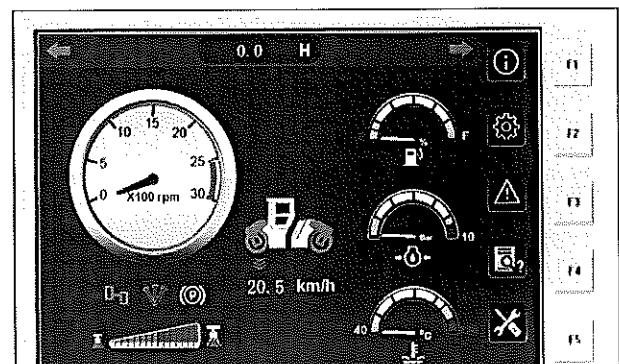

Fig.4-65

- Open water valves at water outlet of the water tank.

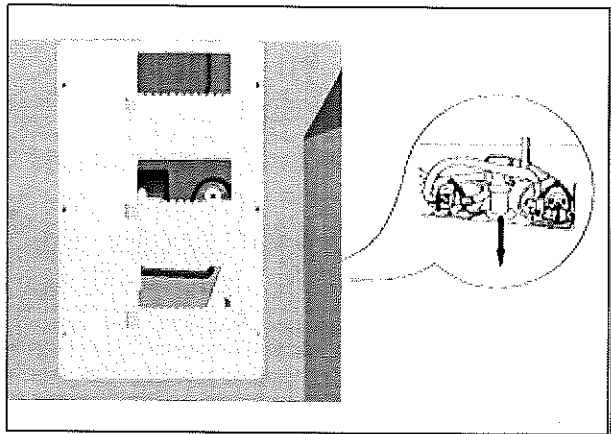

Fig.4-66

- Start water spraying for a certain period (**See: section 4.11 "Correct operation for water spraying operation" on page 4-31**), and check the water pipe for leaks. In case of leaks, stop spraying water first, and then carry out troubleshooting to prevent water from coming into the water pump. Only when the water pipe is well sealed can the water spraying be started again.

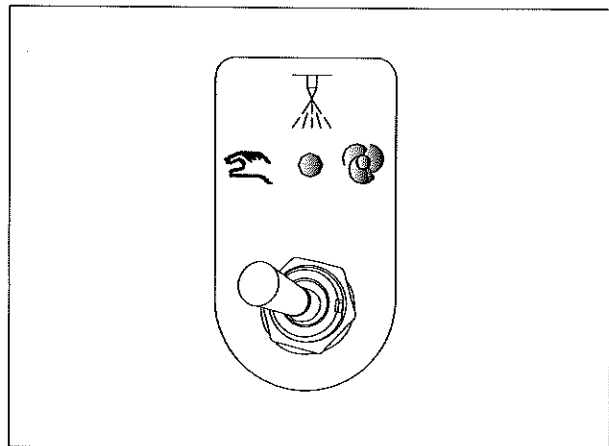

Fig.4-67

#### 4.11.1 Manual water spraying mode

Switch the water spraying control switch to the MANUAL position, then operate the water flow control switch. When the water spraying control switch is turned to the middle position, the roller stops water spraying.

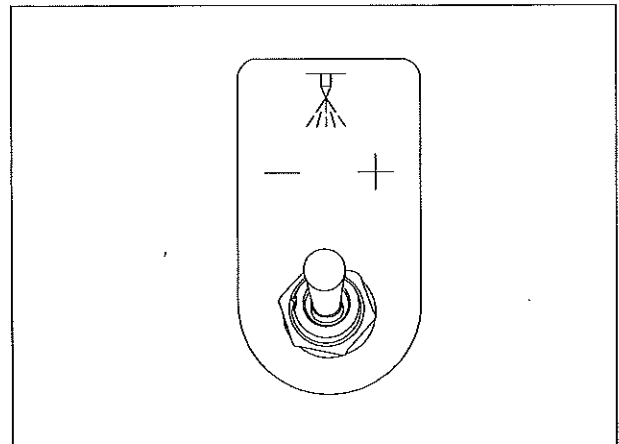

Fig.4-68

#### 4.11.2 Auto water spraying mode

Switch the water spraying control switch to the AUTO position into the auto water spraying mode. Under this mode, the roller can carry out continuous water spraying and intermittent water spraying.

- Continuous water spraying means there is no stop during water spraying;
- Intermittent water spraying means the roller sprays water at a interval. The default interval is 4 seconds.

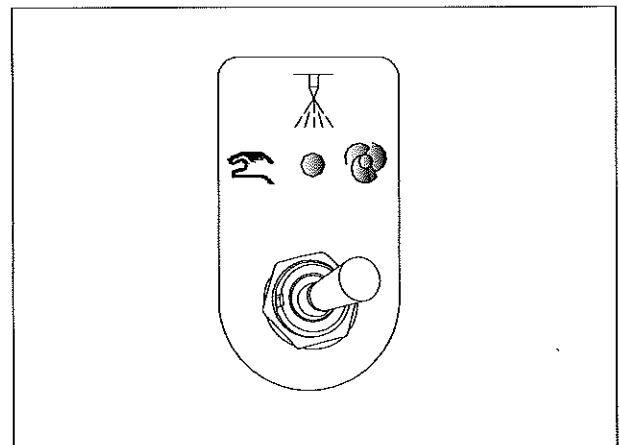

Fig.4-69

Switching water spraying modes and adjustment of intervals can be done through the switches on the panel.

### 4.12 Check after Each Work Day

- Inspect your roller and check the work equipment of roller. Check for leaks of oil or coolant. Repair it in case of any problem.
- Refuel the tank to maximum level.
- Check the engine compartment for any paper or other debris. Remove them, if any, in order to prevent fire.
- If the ambient temperature is below  $-35^{\circ}\text{C}$ , make sure to drain the cooling water of radiator and engine (SANY uses the type of antifreeze liquid that freezes at  $-35^{\circ}\text{C}$ ).

### 4.13 Correct Driving According to the Road Condition

#### 4.13.1 Working near ditch edge and road shoulder

When working near ditch edge, keep a safe distance to the edge. If necessary, reinforce it prior to work. See Fig.4-70.

**⚠ WARNING**

There is a potential of tipping over. Operator should pay great attention when working along the ditch edge.

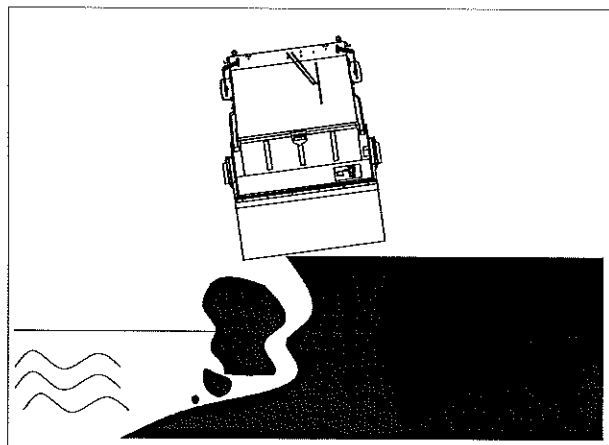

Fig.4-70

When working near road shoulder, low speed gear is recommended. The operator should pay attention to the traveling direction to avoid destroying the road shoulder.

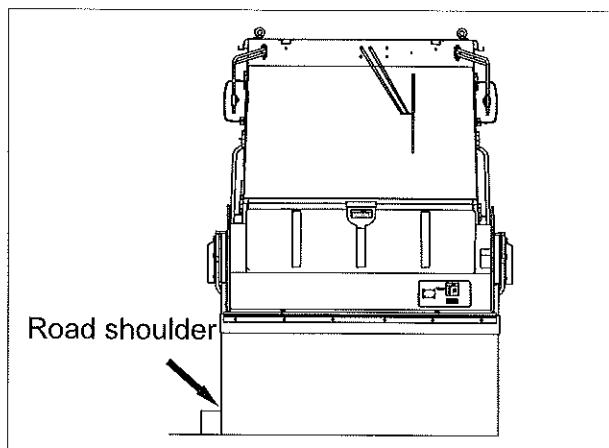

Fig.4-71

### 4.13.2 Working near buildings vulnerable to vibration

When working near buildings such as overbridge and subway, generally the operator shouldn't start vibration to keep them from the vibration wave.

### 4.13.3 Working on the slope

Before working on the slope, survey the gradient of the slope. When the value of gradient is beyond the roller's gradeability, the roller shouldn't be used to work without other facilities. See: **section 7.2 "Specifications of the Equipment" on page 7-2** for more details.

While the gradient of the slope is in the range of the roller's gradeability, the operator can drive upward or downward in a straight line at low gear.

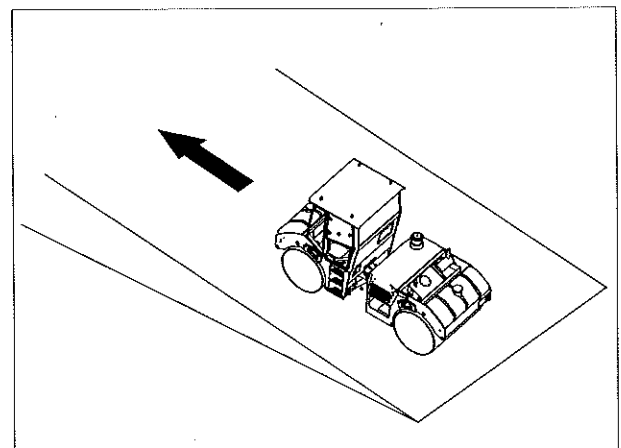

Fig.4-72

## **⚠ WARNING**

**Avoid operating the roller cross the slope to prevent tipping over.**

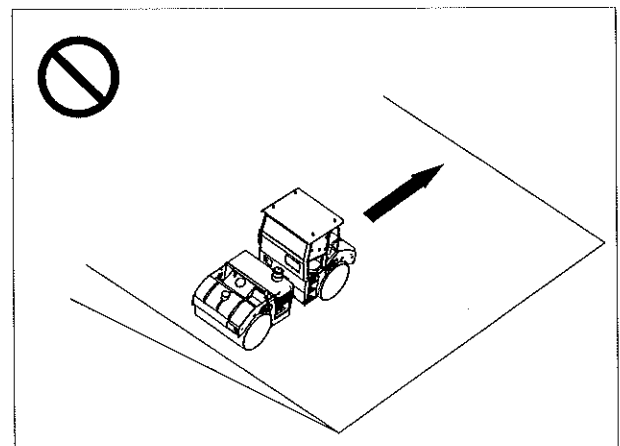

Fig.4-73

### 4.14 Other Auxiliary Equipments

#### 4.14.1 Wiper

When the front and rear windshields get dirty, the operator can use the wiper and washer to clean the windshields.

1. Press down the front wiper switch at the end B. Then the washer sprays detergent.

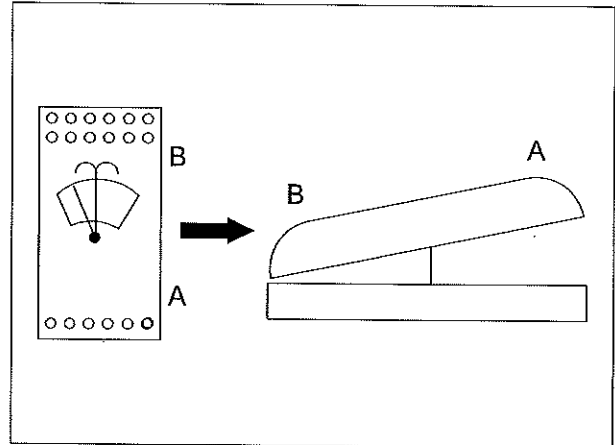

Fig.4-74

2. Then turn the switch A/B to the middle. The front/rear wiper starts to wipe the front/rear windshield.

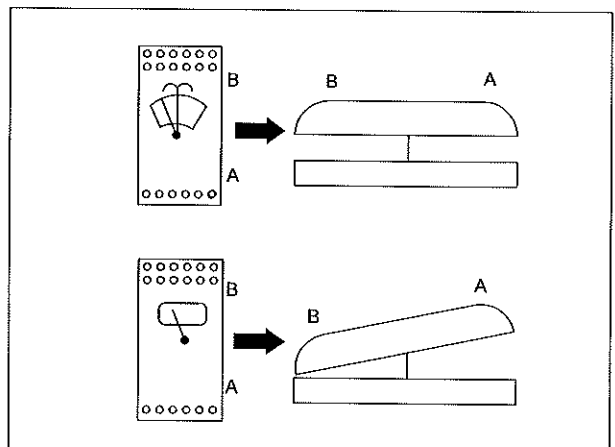

Fig.4-75

3. While the windshield is clean enough, press down the switch at the end A to stop wiping.

### NOTICE

It is necessary to turn on the washer to lubricate the surface of the windshield before turning on the wiper except for rainy day, or it will easily break the arm of the wiper.

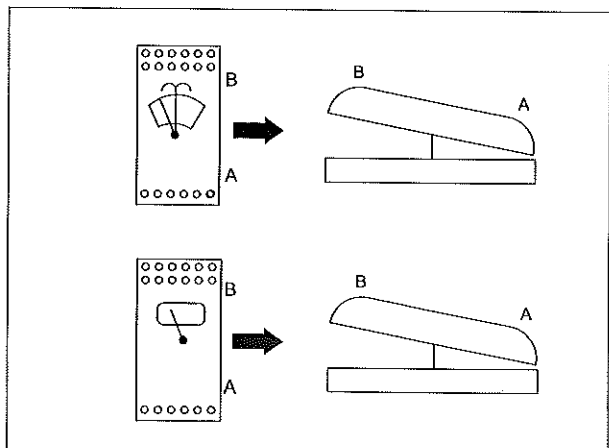

Fig.4-76



#### 4.14.2 Radio operation

For functions of radio panel, see: section 3.2.25 "Radio control panel" on page 3-13.

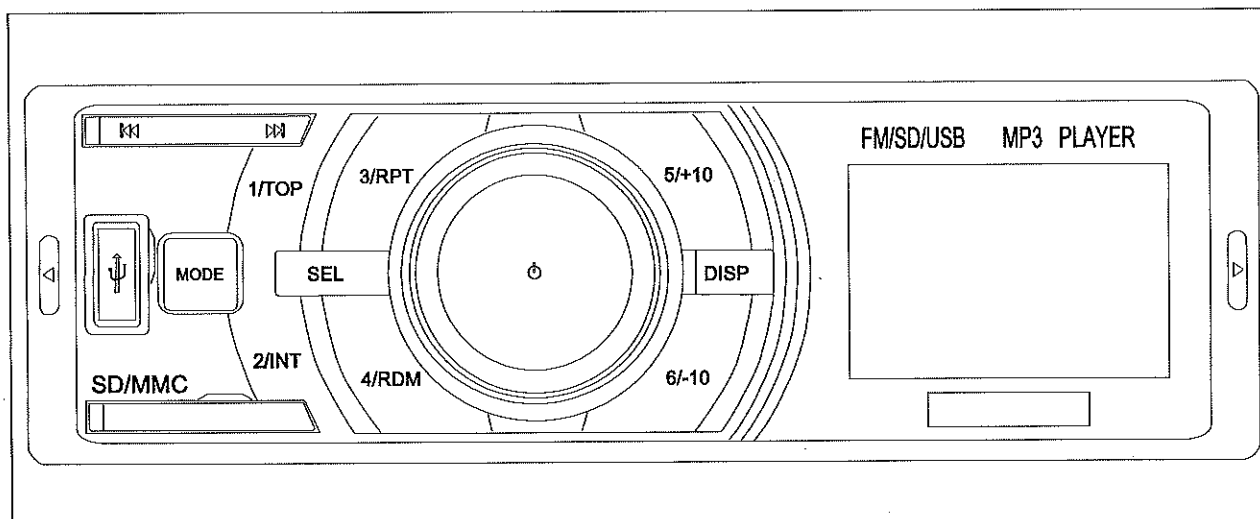

Fig.4-77

Basic operations of radio buttons:

1. Mode switch
 

The default mode is FM/AM. Press the MODE button to switch to FM/AM status under MP3 mode.
2. Wave band selection
 

Press and hold the MODE button, and the radio will enter FM1/FM2/FM3.
3. Manual search
 

Press the [ <<< ] and [ >>> ] to search radio stations upwards or downwards.
4. Manual fine tuning
 

Press [ <<< ] or [ >>> ] button to adjust the frequency of radio station.
5. Manual save
 

Under radio reception state, press and hold any one of the 6 preset buttons for 3 seconds. Then you can save the current radio station into the corresponding memory.

### 6. Preset radio station

Gently press the preset radio station buttons 1-6 to receive the preset radio station under the corresponding wave band.

### Basic operations of MP3 play (see Fig.4-77 on page 4-36):

#### 1. Under radio reception state, press the MODE button into the MP3 mode.

With U disc and SD card inserted, the radio will automatically search songs in MP3 and play music. Gently press [◀◀] or [▶▶] button to play previous or next song.

#### 2. U disc or SD/MMC selection

Under the MP3 mode, press and hold the MODE button to switch U disc or SD/MMC.

#### 3. Play/pause control

Under the MP3 mode, press and hold the middle button to play or pause.

#### 4. DISP button

Under the MP3 mode, press the DISP button to display the current time.

#### 5. Browse

Gently press the [2/INT] button to display songs on U disc or SD/MMC card. Each song name will be played for 5 seconds.

#### 6. Repeated play

Gently press the [3/RPT] button to repeat the current songs.

#### 7. Random play

Gently press the [4/RDM] button to play songs in MP3 randomly.

#### 8. 10 songs upwards/downwards

Press press and hold [◀◀] or [▶▶] button to select 10 songs upwards or downwards.

## NOTICE

**Use qualified U disc and SD card. or it will damage the radio.**

### 4.14.3 Working lights

When the visibility condition is poor, the front and rear working lights can be switched on.

## 4.15 Transportation

### 4.15.1 Transport vehicle

- No matter road or railway transport is applied, select vehicles with appropriate volume and loading capacity to transport the roller. The vehicle must be qualified in maximum loading capacity, engine power, brake capability and others. It would be the best to exclusively transport the product without other machines each time.
- In transportation, take necessary measures to avoid sliding and rolling of the roller.
- Keep a certain distance when passing buildings, bridges, culverts, electric facilities, etc.
- Use the transport vehicle for long-distance machine transportation.

### 4.15.2 Using a slope

1. Use slopes for the loading and unloading for heavy machines and ensure the slope is in the best status. Try to use a metal slope the one has been long laid aside and gone bad must not be used. The slope shall have sufficient width and strength to support the machine and a gradient less than 20%.

2. Ensure the slope is placed between the transport vehicle and the ground correctly. Ensure the slope is not covered with oil, snow, ice or mud. Ensure foundations are laid for the transport vehicle.
3. Start the roller. Select the low gear. Adjust its position to make its front align with the slope. Drive it onto the transport vehicle slowly. Place sleepers at the specified parking position on the transport vehicle in advance.

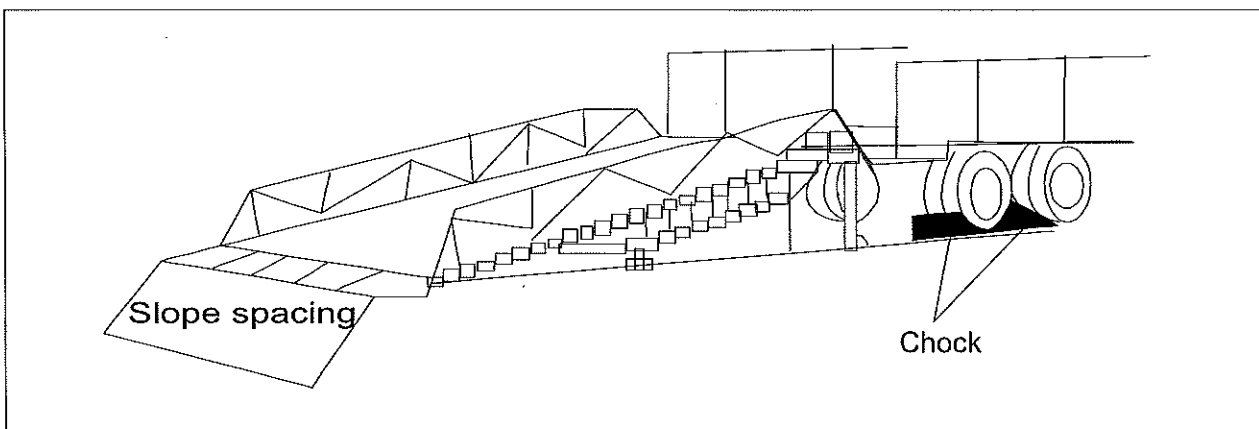

Fig.4-78

4. Fasten slings to fix the front and rear frames.

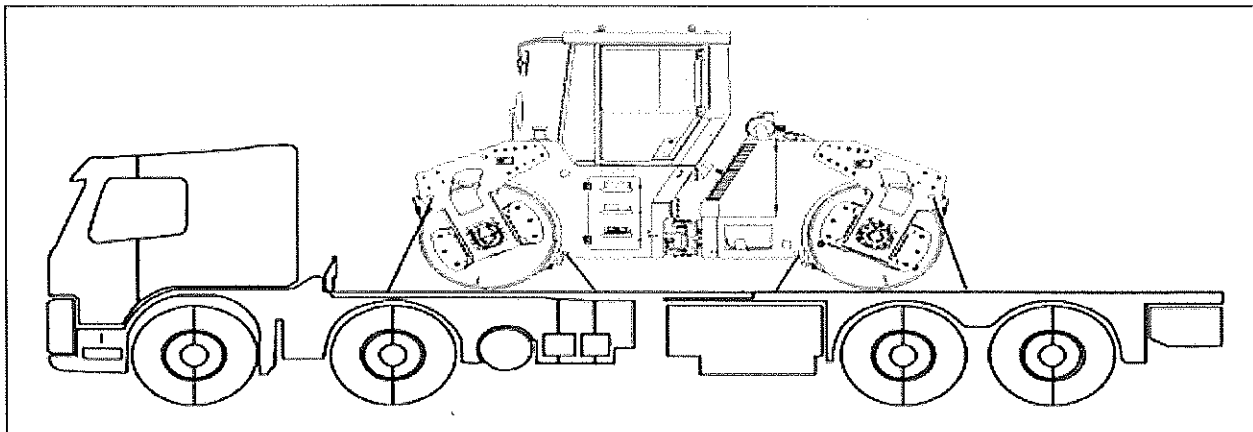

Fig.4-79

### 4.15.3 Shipping

#### 4.15.3.1 Container shipping

##### 1. Preparation

###### (1) Removal of extra high and wide parts

- Remove the warning light.
- Disconnect the washer water pipe from the cabin. Fix the water pipe at the washer tank.
- Remove the cabin: Disconnect the harnesses on the cabin. Remove the connecting bolts between the cabin and cabin floor. Lift the cabin and fix it onto the cabin bracket with bolts.
- Remove the two rearview mirror supports: Remove the connecting bolts between the rearview mirror supports and the cabin.

###### (2) Protection of removed extra high and wide parts

Wrap up the removed interior trim clasp nails, floor screws, hood screws and cover plate with bubble film. Place them in the carton together with the rearview mirror package box. Then put the carton on the bottom plate of cabin.

###### (3) Check before protection

Before protection, make sure the roller coating is qualified and has been dried completely. Make sure the surfaces are clean, dry and without any dust, water, oil or rust.

Make sure the fasteners connecting the roller parts have been treated against rust and are fixed at their original positions.

##### 2. Protection process

Cleaning – rust-proof treatment to exposed non-coated parts – protection of engine – protective coating of complete machine – drying - partial protection – container loading.

**(1) Cleaning**

- Use the detergent 1755EF to clean the exposed non-coated parts such as lampshades, fasteners and tube connectors. Make sure: a. the cloth and paint brushes to be used are clean; b. the cleaned parts are clean and without any dust, rust or other foreign objects.
- After cleaning, dry them with compressed air or clean soft paper/car cleaning paper. Carry out protective treatment after 5-10 min.

**(2) Rust-proof treatment to exposed non-coated parts**

- Apply anti-rust oil GB-019 evenly to the exposed plated parts and aluminum parts such as tube connectors, hydraulic valves, screws, and the coupling disc seat, primary filter support and secondary filter support of the diesel engine.
- Cover the oil cylinder piston rod in advance and remove the cover after applying protective coat. Use a piece of clean cloth dipped with diluent to clean these parts. After the solvent volatilizes, coat these parts with anti-rust oil 377-HF evenly.

**(3) Protection of engine**

Apply protective coat AP1520 to the engine and the internal surfaces of covering parts for sealing in accordance with Article 5.5 in Q/SY 042 025-2008 Specification for the Protection of Exported Engineering Machinery.

**(4) Protective coating of complete machine**

Apply protective wax AP585 to the following parts in accordance with Article 5.7 in Q/SY 042 025-2008 Specification for the Protection of Exported Engineering Machinery: cabin, front frame, rear frame, center articulation frame, covering parts, hydraulic elements, tube connectors, plated parts, and spare parts without anti-rust oil and made of anticorrosive

materials such as stainless steel, copper, nickel and chrome.

#### (5) Drying

Dry the coated complete machine in accordance with Article 5.8 in Q/SY 042 025-2008 Specification for the Protection of Exported Engineering Machinery. Place the machine in a room above 25 °C for 2h-4h or below 25°C for 4h-12h.

#### (6) Partial protection

Wrap up the control side box, control console, electric control cabinet, and fixing points with bubble film and tape. Then place 10-12 packages of silica-gel desiccant. Seal the electric connectors.

### 3. Export container loading

#### (1) Container loading of basic machine

Start the roller. Adjust the engine speed to 1500rpm. Select gear 1. Adjust the roller position to be aligned with the container entrance. Drive the roller at a low speed into the container. Set a sleeper at the sill of the container for transition. Carefully observe the distances between the machine sides and the container to avoid the paint damage caused by interference. Stop driving when the front wheels contact with the limit sleeper. At last, shut down the machine and disconnect it from the power supply.

#### (2) Fixing of basic machine

Park the roller at the center in the container. Set wedge blocks before/behind the drums and at the points of contact with container. Fix the wedge blocks with round steel nails. Connect the fixing hole on the machine with the hook in container by iron wires. This is to prevent roller bounce. Set wearable cloth in the fixing hole for protection.

#### 3) Container loading and Fixing of cabin

Use a forklift truck to load the cabin together

with the cabin bracket into the container. Then fix them with iron wires.

**(4) Fixing of removed parts box**

Seal the parts box containing the removed parts. Then put it on the platform at the left upper corner in the cabin.

**(5) Fixing of attached accessories box**

Lift the wooden box containing the attached accessories to the middle under the cabin bracket with a forklift truck. Then, fix the bottom wood slats of the box to the container floor with steel nails.

**(6) Lifting of container with a reach stacker**

Use a reach stacker to lift the container stably. Later, keep the reach stacker stationary and drive the flatcar to the place just under the container. Stably lower the container to the flatcar and fasten it.

**(7) Departure:** Carry out final check before departure. After getting out of the container, lock the container door.

**4. Oil level standard**

**Table 4-1 Oil Level Standard**

No.	Item	Standard
1	Hydraulic oil	Between 1/2 ~ 2/3 of the level gauge scale
2	Diesel oil	1/4 at the electronic fuel gauge

**5. Key management**

**Table 4-2 Key List**

No.	Name	Qty	Unit	Remarks
1	Ignition key	2	Piece	These 3 kinds of keys are interchangeable.
2	Cabin door key (left and right)			
3	Fuel tank key			
4	Electric control cabinet key			
5	Battery box key			
6	Engine hood key			
Total		4	Piece	



#### 4.15.3.2 Non-container shipping

##### 1. Preparation

Before protection, make sure the roller coating is qualified and has been dried completely. Make sure the surfaces are clean, dry and without any dust, water, oil or rust.

Make sure the fasteners connecting the roller parts have been treated against rust and are fixed at their original positions.

##### 2. Protection process

Cleaning - rust-proof treatment to exposed non-coated parts - protection of engine - protective coating of complete machine - drying - partial protection - handover at the port - shipping.

###### (1) Cleaning

- Use solvent gasoline or paint diluent to clean the exposed non-coated parts such as lampshades, fasteners, tube connectors, bolts and nuts. Make sure: a. the cloth and paint brushes to be used are clean; b. the cleaned parts are clean and without any dust, rust or other foreign objects.
- After cleaning, dry them with compressed air or clean soft paper/car cleaning paper. Carry out protective treatment after 5-10 min.

###### (2) Rust-proof treatment to exposed non-coated parts

Apply anti-rust oil 377-HF evenly to the exposed plated parts and aluminum parts such as tube connectors, hydraulic valves, screws, and the coupling disc seat, primary filter support and secondary filter support of the diesel engine. Then wrap them up with polyethylene film (or bags) against water. Cover the oil cylinder piston rod in advance and remove the cover after applying protective coat. Use a piece of clean cloth dipped with diluent to clean these parts. After the solvent volatilizes, coat these parts with anti-rust oil

377-HF evenly. Then wrap it up with cylinder sleeve. At last, fasten it with bandage.

(3) Protection of engine

Apply protective coat AP1520 to the engine and the internal surfaces of covering parts for sealing.

(4) Protective coating of complete machine

Apply protective wax AP585 to the following parts: cabin, front frame, rear frame, center articulation frame, covering parts, axles, hydraulic elements, tube connectors, plated parts, and spare parts without anti-rust oil and made of anticorrosive materials such as stainless steel, copper, nickel and chrome.

(5) Drying

Dry the coated complete machine.

(6) Partial protection

- Wrap up the operation box with bubble film and tape. Place silica-gel desiccant in the package.
- Seal the electrical connectors with tape against water. Protect parts of cabin connectors by the same means.
- Wrap up the 4 lamps at the front and rear parts of cabin with polyethylene film.
- Wrap up the products to be stepped on with bubble film and tape.
- Wrap up the cylinder axis pin with sleeve. Fix the related parts with hose clamps.

3. Handover at the port

Carry out inspection after the goods arrive at the port and before shipping. Accept the goods only after the following conditions are met.

- The overall paint is undamaged.
- The seals for the rearview mirror carton, attached accessories box and document box are intact and undamaged.

- The cabin doors and windows and the covering parts are closed and locked.
- The articulation fixing rod is locked.

#### 4. Shipping

##### (1) Equipment shipping

- General cargo ship

Carry out lifting according to the lifting nameplate. Wrap the steel rope at the lifting eye with wearable cloth to protect the paint there. Lift and lower the roller slowly to protect its structure against damage.

- Roll-on-roll-off ship

For roll-on-roll-off ships, a platform or slope shall be used to connect the ship and wharf. The gradient of the platform or slope shall not exceed 35°. This is to avoid steering when driving up/down the slope. If steering is required, drive the machine back to the ground. After correcting the direction, drive it onto the slope.

##### (2) Equipment fixing

Fix the roller with solid pull rods. Wedge the front and rear drums with triangle timber blocks. Take other measures to fix the machine firmly. In addition, drain the engine water tank. Reserve some fuel for dispatch. Disconnect the circuit between the battery and the frame.

#### 5. Oil level standard

**See Table 4-1 on page 4-43** for the oil level standards.

#### 6. Key management

Complete the key handover procedures. **See Table 4-2 on page 4-43** for the key list.

BLANK PAGE

# SANY

## Maintenance

### 5. Maintenance

5.1 Maintenance Information .....	5-1
5.1.1 Notes on maintenance .....	5-1
5.1.2 Notes on engine performance .....	5-1
5.1.3 Notes on fuel system .....	5-2
5.1.4 Notes on hydraulic system .....	5-2
5.2 Requirements on use of oil & fluids .....	5-3
5.2.1 Introduction of functional oil & fluids .....	5-3
5.2.1.1 Engine oil .....	5-3
5.2.1.2 Fuel .....	5-4
5.2.1.3 Lubricant .....	5-5
5.2.1.4 Grease .....	5-5
5.2.1.5 Coolant .....	5-5
5.2.2 Oil & Fluids Selection .....	5-6
5.2.2.1 General requirements .....	5-6
5.2.2.2 Requirements of oil and fluids .....	5-8
5.2.3 Filling capacities .....	5-12
5.3 Test Run Instructions .....	5-13
5.4 Maintenance .....	5-14
5.5 Daily Maintenance .....	5-15
5.5.1 Clean .....	5-16
5.5.1.1 Roller .....	5-16
5.5.1.2 Air filter .....	5-16
5.5.2 Check .....	5-17
5.5.2.1 Safety, Operation & Maintenance Manual .....	5-17
5.5.2.2 Operating functions .....	5-17

5.5.2.3 Lamps and horn	5-17
5.5.2.4 Air filter	5-18
5.5.2.5 Engine air intake pipeline	5-22
5.5.2.6 Engine oil level	5-22
5.5.2.7 Engine coolant level	5-22
5.5.2.8 Engine belt	5-23
5.5.2.9 A/C system	5-25
5.5.2.10 Hydraulic oil level	5-27
5.5.2.11 Fuel level	5-27
5.5.2.12 Electrical system	5-28
5.5.2.13 Oil/water spraying system	5-30
5.5.2.14 Oil tank and oil lines	5-30
5.5.2.15 Oil leaks	5-30
5.5.2.16 Drums and dampers	5-33
5.5.2.17 Connections and tightness	5-33
5.6 Initial 50 Hour Maintenance	5-34
5.6.1 Secure the machine for maintenance	5-34
5.6.2 Change	5-35
5.6.2.1 Engine oil	5-35
5.6.2.2 Engine oil filter	5-37
5.6.2.3 Fuel filter	5-38
5.6.2.4 Oil water separator element	5-39
5.6.2.5 Lubricant for drums	5-40
5.6.2.6 Lubricant for reducer	5-41
5.6.3 Check	5-42
5.6.3.1 Engine belt	5-42
5.6.3.2 Compressor belt	5-42
5.7 Initial 250 Hour Maintenance	5-43
5.7.1 Secure the machine for maintenance	5-43
5.7.2 Replace	5-44
5.7.2.1 Lubricant for drums	5-44
5.7.2.2 ELubricant for reducer	5-44
5.8 Initial 500 Hour Maintenance	5-44
5.8.1 Secure the machine for maintenance	5-44
5.8.2 Maintenance	5-45
5.9 Every 250 Hour Maintenance	5-45
5.9.1 Replace	5-46

5.9.1.1 Engine oil	5-46
5.9.1.2 Engine oil filter element	5-46
5.6.1.3 Fuel filter	5-47
5.6.1.4 Oil water separator element	5-47
5.10 Every 500 Hour Maintenance	5-48
5.10.1 Add lubricant	5-49
5.10.2 Replacel	5-49
5.10.2.1 Air filter main element/safety element	5-49
5.10.2.2 Lubricant for drums	5-50
5.10.2.3 Lubricant for reducer	5-50
5.10.3 Check	5-50
5.10.3.1 Key welding parts, driving parts	5-50
5.10.3.2 Dampers	5-50
5.11 Every 1000 Hour Maintenance	5-51
5.11.1 Check/maintain-A/C (if equipped)	5-51
5.11.2 Replace	5-56
5.11.2.1 Hydraulic oil	5-56
5.11.2.2 Hydraulic oil filter element	5-57
5.11.2.3 Coolant	5-58
5.12 Other maintenance items	5-59
5.12.1 Clean the fuel tank	5-59
5.12.2 Clean the radiator	5-60
5.13 Maintenance for long-time storage	5-63
5.13.1 Engine	5-63
5.13.2 The roller	5-64
5.14 Antifreezing Maintenance	5-65
5.15 Check after Maintenance	5-66

**⚠ WARNING**

**Read and understand all safety precautions and instructions in this manual before reading any other manuals provided with this machine and before operating or servicing the machine. Failure to do this can cause property damage, personal injury or death.**

---



## 5 MAINTENANCE

### 5.1 Maintenance Information

#### 5.1.1 Notes on maintenance

Read all applicable safety instructions when you service the roller.

The reliability of roller will be increased and the lifetime of essential components will be prolonged with thorough machine maintenance. The faults result from not observing the safety instructions will cause more effort than maintenance work.

During maintenance, you should:

- Completely clean the roller and engine before maintenance.
- Park the roller on level ground for maintenance.
- When carrying out maintenance work, shut down the engine.
- Depressurize the hydraulic lines before working on them.
- Cut off the battery power supply before working on the electrical parts.
- Collect the effluent lubricant, coolant and fuel to prevent contamination.

#### 5.1.2 Notes on engine performance

The rate between combustion air and fuel injection of the diesel engine has been carefully adjusted. Engine's performance, temperature level and the quality of the exhaust gas are determined by that.

You should consult the service department of our company or engine manufacturer if the machine has to work with full load in the thin air (at high altitude).

### 5.1.3 Notes on fuel system

The service life of diesel engine mainly depends on the fuel purity. During maintenance, you should:

- Make sure the engine is free of dirt and water or the injection parts may be damaged.
- Never use a galvanized iron barrel to store fuel.
- Before drawing the fuel out from a barrel, store the barrel for a long time.
- Prevent the fuel suction pipe from churning the fuel barrel.
- Never draw the fuel out on the bottom of the barrel.
- The fuel left at the bottom of the barrel can't be used by engine. It is used for cleaning.

### 5.1.4 Notes on hydraulic system

Keep the hydraulic system from contaminating. Make sure no dirt or any other dirty substance enters the system, as even tiny particles may scratch the valve, make pumps to seize or block the throttle or guide hole, resulting in high repair cost.

- If the oil level is found to have dropped during the daily check, check all lines and hydraulic elements for leaks.
- Seal the external leakage at once. If necessary, inform the relevant after-sales service department for repair.
- Never leave the barrel containing hydraulic oil in the open air. The water may enter the barrel through the oil outlet because of weather changes.
- Use oil filling and filtering devices to refill hydraulic oil. This device is equipped with a filter that can filter the hydraulic oil and prolong the lifetime of the filter.
- Before removing the connector and oil tank cover, clean them and the surfaces around to prevent dirt from entering the system.

- Unless it is necessary, do not leave the oil filler of the hydraulic oil tank open. Otherwise, the dirt may enter the oil tank.

## 5.2 Requirements on use of oil & fluids

### 5.2.1 Introduction of functional oil & fluids

#### 5.2.1.1 Engine oil

Choose engine oil according to the function and type. Other engine oil meeting the required specifications also can be chosen.

As the viscosity of engine oil varies with the temperature, the local ambient temperature is extremely important for the selection of viscosity grade.

If the ambient temperature is occasionally lower than the applicable temperature limit (for example, using SAE 15W/40 engine oil at  $-15^{\circ}\text{C}$ ), only the engine cold start capability but not the engine will be affected.

The multi-grade oil does not require frequent oil change according to the temperature change. The synthetic oil is better since it can be used under higher temperature and it is more reliable.

The maximum allowable duration for the engine oil is 1 year. If the oil change intervals exceed 1 year, the oil shall be changed at least once a year.

The engine oil used by this machine shall be changed every 250 working hours. This change interval is only applicable for engine adopting diesel oil with sulfur content below 0.5% and in temperature above  $-10^{\circ}\text{C}$ .

When the sulfur content is 0.5%~1% or the temperature is below -10°C, the oil change interval should be shortened half. If the sulfur content is 1~1.5%, the engine oil shall contain TBN, 12 times more sulfur content, with the change interval shortened half.

#### 5.2.1.2 Fuel

### WARNING

- Do not mix diesel with gasoline, alcohol or mixture of gasoline and alcohol, otherwise explosion will be caused.

### NOTICE

- Fuel quality should be controlled strictly, otherwise the water and impurities in the fuel system will cause serious damage to engine pump and nozzle.

Regular diesel oil meeting national and local emission standard is recommended.

The diesel oils below are permitted:

- GB252
- DINEN590
- BS 2869: A1 and A2
- ASTM D 975-78: 1-D and 2-D
- NATO Code F-54 and F-75

Refill the tank to avoid running out of oil. Otherwise, the lube filter and injection lines need to discharge.

Only commercially available diesel fuel can be used. Ensure that the sulfur content is less than 0.5% and no contamination when filling in. Higher sulfur content has negative effect on oil change intervals.

To avoid blocking caused by paraffin, only winter diesel fuel can be used in temperature below 5 °C . The mixture of diesel oil and proper additive can also be used.

#### **5.2.1.3 Lubricant**

Lubricant includes engine oil, gear oil, transmission oil, hydraulic oil, etc.

The proper viscosity grade is determined not only by the minimum outside temperature when the machine is started, but also by the maximum outside temperature while the machine is operated.

Parts that are continuously operated should use the oil with higher viscosity in order to maintain the highest possible oil film thickness.

#### **5.2.1.4 Grease**

Use lithium-based high pressured saponified grease.

#### **5.2.1.5 Coolant**

Antifreeze of organic acid technology (OAT) is adopted.

### **NOTICE**

- **Do not mix coolant with additives of different types.**
- **The protective agent of cooling system must be disposed environmentally.**

## 5.2.2 Oil & Fluids Selection

### 5.2.2.1 General requirements

1. SANY special oil and fluids are recommended.
2. Select oil and fluids with proper quality grade, technical specifications and viscosity as per latest standard of related authorities according to this manual.
3. Failing to use the oil and fluids according to this manual, machine performance may be affected and fault may be caused to relevant parts.
4. To ensure machine performance, oil and fluids of different brands should not be mixed; otherwise, sediments or layers may be caused, which lead to performance degradation or failure, even fault of machine and parts.
5. Disposal of oil and fluids should comply with local laws and regulations.
6. Viscosity selection

- a. Ambient temperature

Ambient temperature refers to the air temperature surrounding the machine. Do check the local temperature and possible air temperature before selection.

Generally, viscosity selection is based on the higher temperature in the standard. When the machine starts, the max. allowable viscosity under ambient temperature could be selected. In extreme cold area, it's better to use parts heating system and oil and fluids of higher viscosity.

- b. Viscosity grade

Proper viscosity depends on the min. ambient temperature, which is the temperature for machine startup and operation.

To determine proper viscosity grade under the min. ambient temperature for startup and operation, refer to the "Min. Temp." in the following tables. To determine proper viscosity grade under the max. ambient temperature for startup and operation, refer to the "Max. Temp." in the following tables. Unless specially specified, the max. allowable viscosity grade under ambient temperature should be selected for machine startup.

For long-term operation, oil and fluids of higher viscosity should be selected for transmission and differential, so as to maintain the thickest film.

7. Oil and fluids used under low temperature.

- a. Before start-up of the machine, ensure engine oil, transmission oil, hydraulic oil and other fluids are fully flowing. Take out the dipstick, check that the oil or fluid flows down the dipstick easily. Oil or fluid diluted by kerosene is prohibited.
- b. If different oil or fluid is replaced under low temperature, the filter element should be replaced too. Otherwise, the filter element and housing will be solidified. Drain the oil and fluids in hydraulic cylinder and pipelines. After replacement, run the machine to circuit the oil and fluid.
- c. Select proper viscosity according to this manual.
- d. In case of change of temperature, change proper oil and fluids according to this manual.

5.2.2.2 Requirements of oil and fluids

Table 5-1 Engine Oil Under Different Ambient Temperature

Part/System	Type, quality grade & technical spec. of oil & fluids	Viscosity grade of oil & fluids	Ambient temp. (°C)	
			Min. Temp	Max. Temp.
Engine crankcase	Diesel Engine Oil • API CI-4 • GB 11122	SAE 0W-20	-40	10
		SAE 0W-30	-40	30
		SAE 0W-40	-40	40
		SAE 5W-30	-30	30
		SAE 5W-40	-30	40
		SAE 10W-30	-20	40
		SAE 10W-40	-20	50
		SAE 15W-40	-15	50
Note	1. Unless specially specified, this machine adopts Diesel Engine Oil CI-4 15W-40 when delivery. It is specially used for SANY machine with applicable temperature of -15°C to 50°C . 2. For engine with emission of China II or Euro II standard for off-road machine, API CH-4 or lubricant of higher grade should be used. 3. For engine with emission of China III or Euro III standard for off-road machine, API CH-4 or lubricant of higher grade should be used. 4. For engine with emission of Euro IV standard for off-road machine, API CJ-4 or lubricant of higher grade should be used.			



Table 5-2 Gear Oil Under Different Ambient Temperature

Part/System	Type, quality grade & technical spec. of oil & fluids	Viscosity grade of oil & fluids	Ambient temp. (°C)	
			Min. Temp	Max. Temp.
Transfer case/Reducer	Industrial Enclosed Gear Oil (mineral oil) • DIN 51517 Part 3-group CLP • ISO 12925-1 CKD • AIST 224 • AGMA 9005-E02:EP • GB 5903	150	-10	40
		220	-5	50
	Industrial Enclosed Gear Oil (PAO) • DIN 51517 Part 3=>group CLP • NF-ISO 6743-6 Category CKD • AIST 224 • AGMA 9005-E02 • GB 5903	150	-40	50
		220	-40	50
Note	1. Unless specially specified, this machine adopts Industrial Enclosed Gear Oil L-CKD 150 or L-CKD 220 when delivery. It is specially used for SANY machine with applicable ambient temperature of -10 °C to 40°C for L-CKD 150 or -10 °C to 50°C for L-CKD 220.			

Table 5-3 Automotive Gear Oil Under Different Ambient Temperature

Part/System	Type, quality grade & technical spec. of oil & fluids	Viscosity grade of oil & fluids	Ambient temp. (°C)	
			Min. Temp	Max. Temp.
Rear axle	Heavy-duty Automotive Gear Oil • API GL-5 • GB 13895	SAE 75W-90	-40	30
		SAE 80W-90	-20	40
		SAE 85W-90	-15	40
		SAE 85W-140	-10	50
		SAE 90	0	40
Note	1. Unless specially specified, this machine adopts Heavy-duty Automotive Gear Oil GL-5 85W-140 when delivery. It is specially used for SANY machine with applicable temperature of -10 °C to 50°C .			

Table 5-4 Hydraulic Oil Under Different Ambient Temperature

Part/System	Type, quality grade & technical spec. of oil & fluids	Viscosity grade of oil & fluids	Ambient temp. (°C)	
			Min. Temp	Max. Temp.
Hydraulic system	Normal Temperature Hydraulic Oil HM / L-HM Anti-wear Hydraulic Oil • AFNOR NF E 48-603 HM • ISO 11158 L-HM • CINCINNATI P68, P69, P70 • EATON-VICKERS M-2950 S, I-286 S • PARKER-DENISON HF-0, HF-1, HF-2 • Q/SH303 0550 • GB 11118.1	32	-20	5
		46	-20	10
		68	-15	50
	Wide-temperature Hydraulic Oil HV / L-HV Low-temperature Hydraulic Oil • AFNOR NF E-48-603 HV • ISO 6743/4 HV • DIN 51524 P3 HVLP • CINCINNATI P68, P69, P70 • EATON(VICKERS) M-2950 S, I-286 S • Q/SH303 0661 • GB 11118.1	32	-30	10
		46	-30	15
		68	-25	50
	Aircraft hydraulic oil • SH 0358 • Q/SH PRD0476	10#	-40	5
Note	<p>1. Unless specially specified, this machine adopts Normal Temperature Hydraulic Oil HM 68/L-HM Anti-wear Hydraulic Oil when delivery. It is specially used for SANY machine with applicable temperature of -15 °C to 50°C . Change the oil type according to different environment temperature.</p> <p>2. Unless specially specified, hydraulic oil of the highest viscosity is recommended to maintain the thickest oil film, so as to ensure system performance and prolong its service life.</p> <p>3. In case of long-term work under high temperature or pressure, wide-temperature hydraulic oil is recommended for the hydraulic system.</p>			

Table 5-5 Grease Under Different Ambient Temperature

Part/System	Type, quality grade & technical spec. of oil & fluids	Speed with load	NLGI grade	Ambient temp. (°C)	
				Min. Temp	Max. Temp.
Motor spline	EP Lithium-based Lubricating Grease • ISO 6743-9: L-XBCEB 2 • DIN 51502: MPF2K-25 • SH/T 0587	/	2	-25	50
	EP Lithium-based Lubricating Grease • ISO 6743-9: L-XBCEB 3 • DIN 51502: MPF3K-20 • SH/T 0587		3	-20	50
Travelling bearings, articulated frame or other grease-lubricated parts	EP Lithium-based Lubricating Grease • ISO 6743-9: L-XBCEB 1 • DIN 51502: KP1K-30 • GB/T 7323	High	1	-30	40
	EP Lithium-based Lubricating Grease • ISO 6743-9: L-XBCEB 2 • DIN 51502: KP2K-25 • GB/T 7323	High	2	-25	50
		Mid	2	-20	40
		Low	2	-25	40
	Tank Lithium-based Lubricating Grease GJB 4364	/	2	-50	50
Note	<p>1. Unless specially specified, this machine adopts the following fluids:</p> <p>a. Motor spline: EP Lithium-based Lubricating Grease 3# with Molybdenum Disulfide. It is specially used for SANY machine with applicable temperature of -20°C to 50°C .</p> <p>b. Grease-lubricated parts: Extreme Pressure Lithium-based Lubricating Grease 2#. It is specially used for SANY machine with applicable temperature of -25°C to 50°C .</p>				

Table 5-6 Coolant Under Different Ambient Temperature

Part/System	Type, quality grade & technical spec. of oil & fluids	Viscosity grade of oil & fluids	Ambient temp. (°C)	
			Min. Temp	Max. Temp.
Cooling system (Engine radiator)	Antifreeze • OAT • GB 29743	-35	-30	50
		-45	-40	50
Note	1. Unless specially specified, this machine adopts Antifreeze OAT -45 when delivery. It is specially used for SANY machine with applicable temperature of -40°C to 50°C .			

Table 5-7 Diesel Oil Under Different Ambient Temperature

Part/System	Type, quality grade & technical spec. of oil & fluids	Grade of oil (as per condensation point)	Ambient temp. (°C)	
			Min. Temp	Max. Temp.
Fuel system (Diesel engine)	Regular diesel oil GB 252	Diesel Oil 5#	8	50
		Diesel Oil 0#	4	50
		Diesel Oil -10#	-5	50
		Diesel Oil -20#	-14	50
		Diesel Oil -35#	-29	50
		Diesel Oil -50#	-44	50
Note	1. Unless specially specified, this machine adopts Diesel Oil 0# when delivery. 2. Regular diesel oil meeting national and local emission standard is recommended.			

### 5.2.3 Filling capacities

Table 5-8 Oil &amp; Fluids Filling Capacities

Part/System	Type, quality grade & technical spec. of oil & fluids	Dosage (L)
Fuel tank	Diesel oil 0#	about 230
Diesel engine crankcase	Diesel engine oil CI-4 15W-40	about 9
Vibratory drum	Industrial Enclosed Gear Oil L-CKD 220	about 22
Reducer		about 3.6
Travelling bearings/	EP Lithium-based Lubricating Grease 2#	about 2/3
Hydraulic oil tank	Normal temperature hydraulic oil HM 68	about 100
Water tank of diesel engine	Antifreeze OAT -45	about 26
Note	1. Without special requirements, above oil and fluids are used for this equipment. Sany special oil and fluids are recommended. 2. Proper fluid types should be selected according to different environment temperature.	

### 5.3 Test Run Instructions

The maintenance below must be applied for the new machine or overhauled engine.

Check the engine oil level twice a day after every 250 working hours.

According to the load, the engine oil consumption become normal after running for 100-250 h.

After running for 50h, you should do as follows:

- Check the engine for leaks.
- Tighten bolts on the intake/exhaust pipes, oil pan and engine base.
- Tighten the screws on the machine.

After running for 250h, you should do as follows:

- Change the oil in vibration excitation chamber for the first time.
- Change gear oil in vibratory drum reducer for the first time.
- Change the engine oil. Change the engine oil filter.

After running for 500h, you should do as follows:

- Change the oil in vibratory drum reducer for the second time.
- Change the oil in vibration excitation chamber for the second time.

## 5.4 Maintenance

- The technical maintenance for the roller is divided into three kinds, namely routine maintenance, regular maintenance and one-off maintenance (troubleshooting).
- The intervals regulated in regular technical maintenance are the same with those specified in the Engine User's Guide.
- The engine shall be maintained in accordance with the Engine User's Guide.

**NOTE:** The time for regular maintenance is calculated from the engine start.  
Every time after 1000h regular maintenance, the roller enters into the next new cycle of regular maintenance.

Prior to any maintenance, confirm the following items:

- Place the machine on even ground, shut down the engine, and remove the ignition switch key.
- Apply the parking brake switch.
- Ensure all components of the roller cool down.

**NOTE:** Only when the engine' running is required during lubrication and maintenance, can the engine keep running.

## 5.5 Daily Maintenance

With the roller secure proceed with the following items:

Clean:

- Roller
- Air filter

Check

- Safety, Operation & Maintenance Manual
- Operating Functions
- Lamps and Horn
- Air Filter
- Engine Air Intake Pipeline
- Engine Oil Level
- Engine Coolant Level
- Engine Belt
- Compressor V-belt
- Crankcase Vent Line
- Exhaust Manifold
- Muffler
- Hydraulic Oil Level
- Fuel Level
- Electrical System
- Water Spraying System
- Oil Tanks and Oil Lines
- Oil Leaks
- Drums and Dampers
- Connection and Tightness
- Washer

Drain:

- Oil Water Separator

## 5.5.1 Clean

### 5.5.1.1 Roller

- Remove the mud, sands and gravels on the roller.
- Remove the sands and mud on the engine and hydraulic elements.
- Remove the sands on the tires.
- Keep all oil fillers clean.

### 5.5.1.2 Air filter

The air filter is installed above the engine. It can be seen by opening the hood.

The steps for cleaning the air filter has been given in the previous section. For more details, see **Section 4.1.2.6 Check the air filter on page 4-5.**

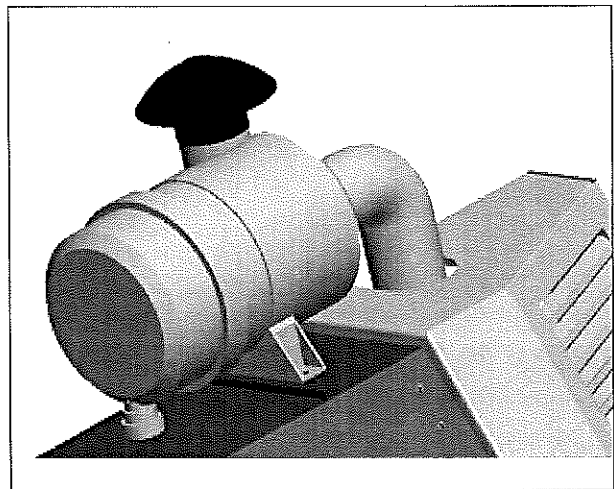

Fig.5-1



## 5.5.2 Check

### 5.5.2.1 Safety, Operation & Maintenance Manual

Be sure the Safety, Operation & Maintenance manual is with the machine in the cab (1).

**NOTE:** If damaged or missing, contact your SANY distributor.

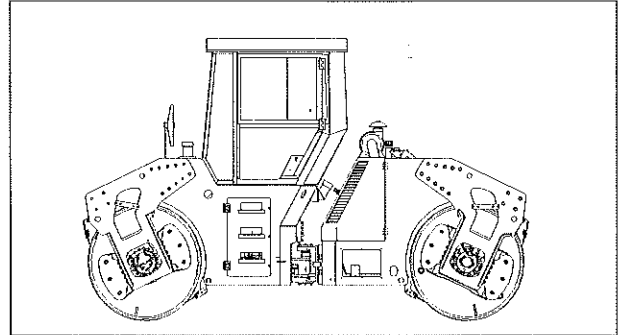

Fig.5-2

### 5.5.2.2 Operating functions

#### **WARNING**

Ensure that no one is on or around the roller when testing operating functions. Failure to ensure this could result in serious injury or possible death.

Check that all functions in the operating cab work correctly. For more details, **see section 3 "System Functions" in this manual.**

### 5.5.2.3 Lamps and horn

Check all lighting systems, be sure all lamps function properly and are not damaged. Check the function of the horn, be sure it is operational.

**NOTE:** If any component is damaged or inoperable, contact your SANY distributor.

#### 5.5.2.4 Air filter

### NOTICE

Maintenance work can be done only after the engine is shut down. Never start the engine after the air filter is removed. Otherwise dust will be drawn into the engine. And this will badly shorten the service life of the engine.

The steps for checking the air filter has been given in the previous section. For more details, see Section 4.1.2.6 Check the air filter on page 4-5.

### NOTICE

Never clean the filter element with gasoline or hot liquid, otherwise it will damage the air filter. After cleaning, check the filter element for damage with a pocket lamp. Replace the filter element if its paper dedusting ball or seal lip is damaged.

- It is meaningless to clean the main filter element if it turns black. Replace it with a new one.
- When the engine is in operation, if the air filter indicator on the SYLD controller flashes, you should maintain the air filter.

Take the following steps to maintain the air filter.

1. Open the covering parts.



Fig.5-3

2. Loosen the end cover of air filter and take it off.

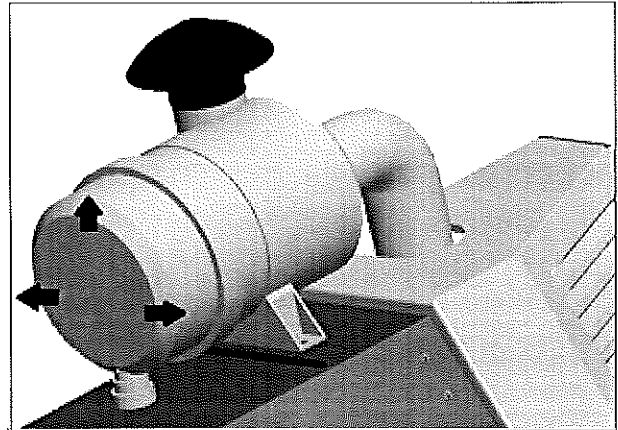

Fig.5-4

3. Clean the end cover and dust evacuator.

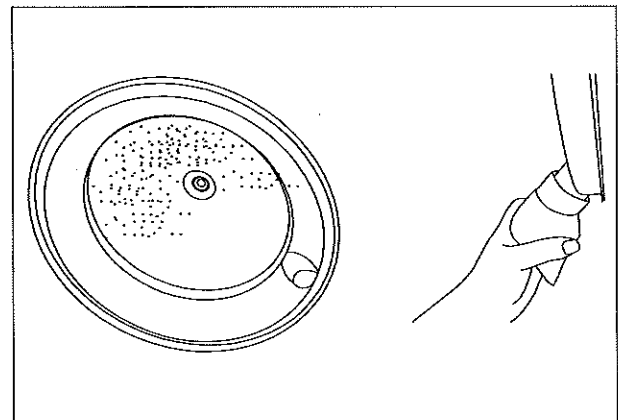

Fig.5-5

4. Carefully loosen the main filter element.  
The main filter is installed on the air intake port for sealing the interior filter cover. Take off the element with care to reduce released dust. Otherwise, the dust will damage the element and reduce the efficiency of the air filter system.

5. Pull the main filter element out of the housing carefully to avoid contact between the filter elements and the housing.

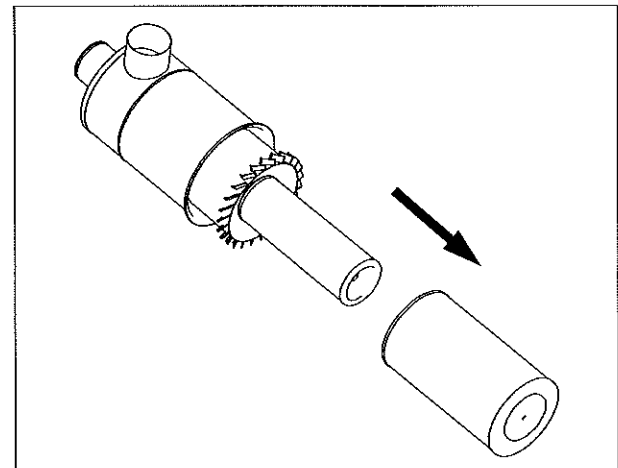

Fig.5-6

6. Check the used main filter element. The main filter element used can display foreign particles causing leakage on the sealing surface. The linear dust on the air side of the filter may leak. Clear the items before fixing a new filter.
7. Clean the main filter element.  
Use dry compressed air (pressure less

than 0.5Mpa) to blow along the inside of the pleats toward the main filter element, and then direct the compressed air along the outside of the pleats to blow from interior to exterior. It's forbidden to clean the main filter element by knocking. The safety filter element is not allowed to be cleaned.

### NOTICE

- **Never adopt the ways of knocking and tapping to clean the filter element, otherwise it will cause the damage to filter paper.**
- **Only when the air filter alarm sounds, can you clean the main filter element. Otherwise, it will shorten service life and normal use of the main filter element.**

8. If the main filter element is damaged, the main filter element and safety element must be replaced regardless the cleaning times is three or less.
9. It's advised to change the main filter element if it has been cleaned for five times. Meanwhile the safety filter element should be changed as well.

10. Reinstall the air filter.

1. Insert the filter element.

Check the filter element, especially inside face of opening for damage due to transportation, clean and improper hold.

### NOTICE

**Never install a damaged filter element, otherwise it will lead to engine fault and shorten service life of the engine.**

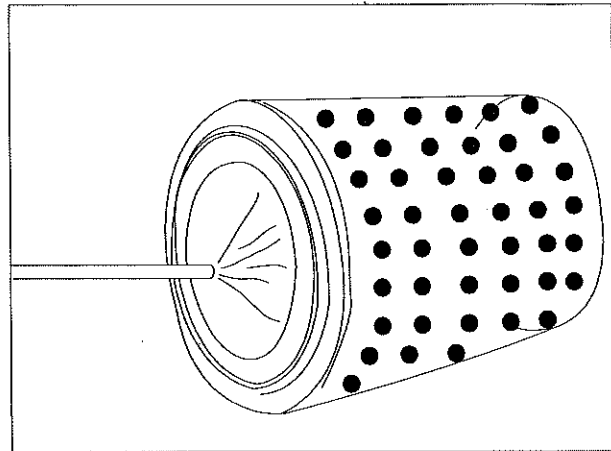

Fig.5-7

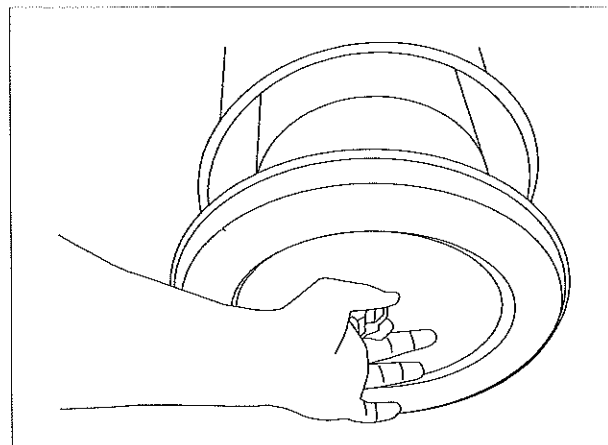

Fig.5-8

2. Install the end cover and tighten the mounting clamps. The dust evacuator is vertically downwards.

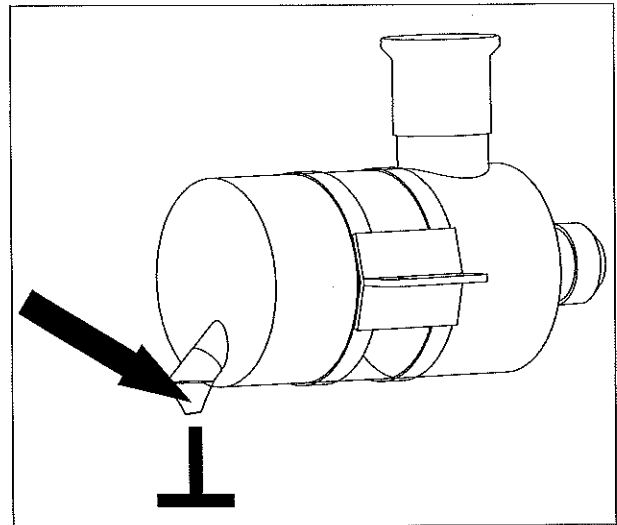

Fig.5-9

**NOTE:** In harsh environment with high intensity of dust, shorten the maintenance and change interval. It is recommended to inform SANY service personnel of maintaining air filter. Customer is responsible for any consequences caused by his own wrong maintenance for air filter.

### ***5.5.2.5 Engine air intake pipeline***

1. Check the T-shape clamp on the intake pipeline is tight. If not, tighten it.
2. Check the intake hose is in good condition. If it is damaged or leaked, replace it.

### ***5.5.2.6 Engine oil level***

The steps for checking engine oil have been described. For details, **See: Section 4.1.2.1 on page 4-2.**

### ***5.5.2.7 Engine coolant level***

## **NOTICE**

**If you try to start a roller that has been shut down, wait for the engine to cool down before you check the coolant level of the engine. Otherwise you may be burned by the spilling hot coolant. Before removing the cover, rotate the cover to release the pressure inside.**

It is important to check the engine coolant level on a daily basis.

The steps for checking the engine coolant level have been described. **See: Section 4.1.2.2 on page 4-3.**

## 5.5.2.8 Engine belt

### ⚠ WARNING

Work on the V-belt must only be performed with the engine shut down. Otherwise people will be badly hurt by the belts.

Check the condition of the engine belt . If excessive wear happens, replace the engine belt at once.

When check the tension of the belt, use the tester for the work.

1. Press the indicator arm (A) of the tester a into the gap of the measuring scale.
2. Lay the measuring unit loosely onto the back of the engine belt.

**NOTE:** To measure the engine belt tension a free length of at least 20 mm is required.

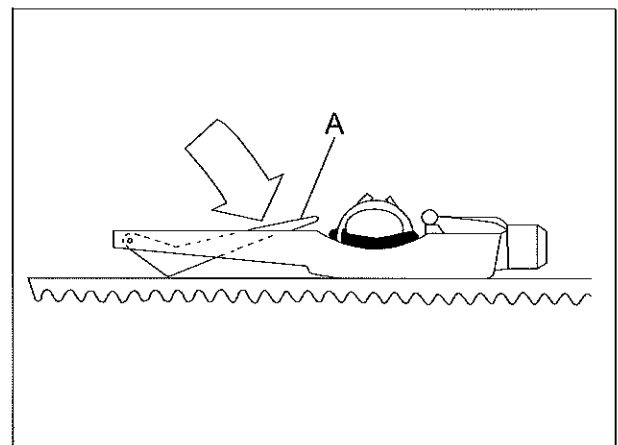

Fig.5-10

3. Operate measuring unit B with a finger (I or II or III), until the pressure spring disengages audibly or noticeably.

**NOTE:** The indicator arm (A) remains in the measured position.

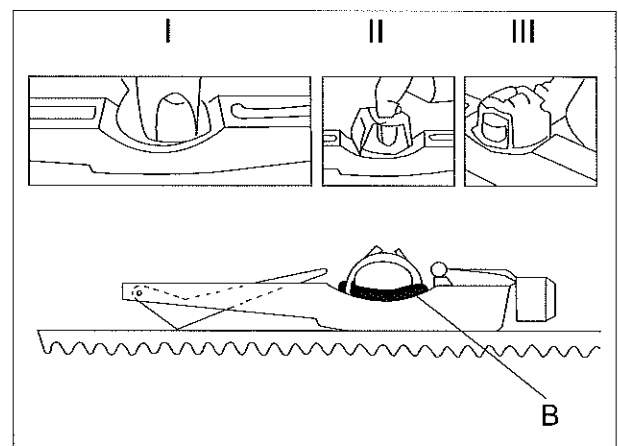

Fig.5-11

4. Remove the measuring unit carefully, without moving the indicating arm.
5. Read the engine belt tension where the upper edge of the indicating arm intersects with the measuring scale.
6. If necessary, retighten the belt.

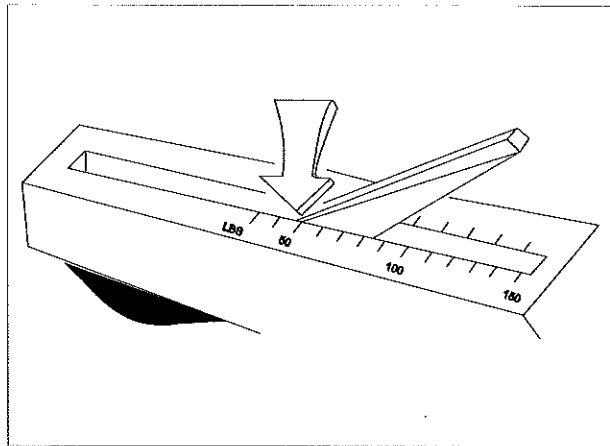

Fig.5-12

Take the following steps to tension the engine belt .

1. Unscrew the bolt.
2. Push the tensioner anticlockwise to tighten the belt. Adjust the belt.
3. Screw the bolt tightly.

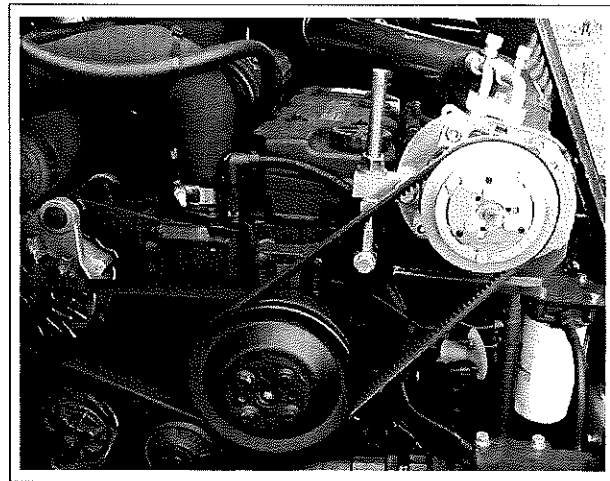

Fig.5-13

Take the following steps to replace the belt.

1. Unscrew the bolt.
2. Push the tensioner to disassemble the damaged belt.
3. Take off the damaged belt.
4. Install a new one and tension it.

**NOTE:**

After the new belt has been installed, run the engine for 15 minutes and shut down the engine to check the belt tension according to the previous steps.



### 5.5.2.9 A/C system

#### Compressor V-belt

### **⚠ WARNING**

**Work on the V-belt must only be performed with the engine shut down. Otherwise people will be badly hurt by the belts.**

#### Check the V-belt

1. Inspect the entire circumference of the V-belt visually for damage and cracks. Replace damaged or cracked V-belts.
2. Check with thumb pressure whether the V-belt can be depressed more than 10 to 15 mm (0.4– 0.6 inches) between the V-belt pulleys, retighten if necessary.

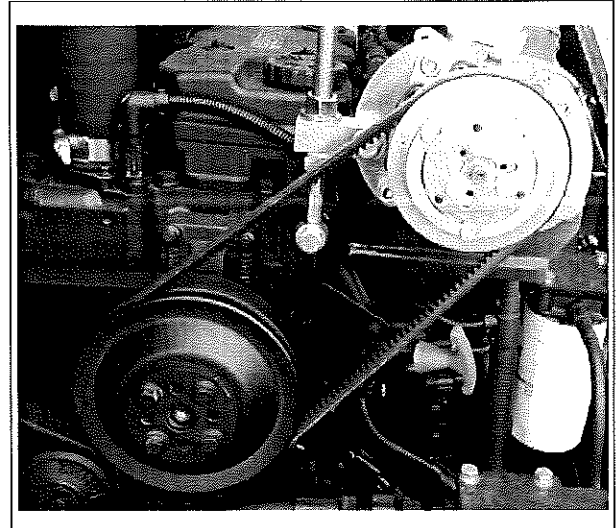

Fig.5-14

#### Tighten the V-belt

1. Slightly loosen nut 2 on bolt 4, and then loosen bolt 6.
2. Press the compressor 5, so adjusting block 3 is moved. Continue to adjust the compressor's position until V-belt 1 tension is reached.
3. Retighten all fastening bolts and nuts.

#### Changing the V-belt

1. Slightly loosen nut 2 on bolt 4, and then loosen bolt 6.
2. Press the compressor (5) to the direction of the engine crankshaft to loose the belt.
3. Take the old V-belt off, and then fit the new V-belt to the V-belt pulleys.
4. Tension the V-belt as previously described.
5. Check the V-belt tension after a running time of 30 minutes.

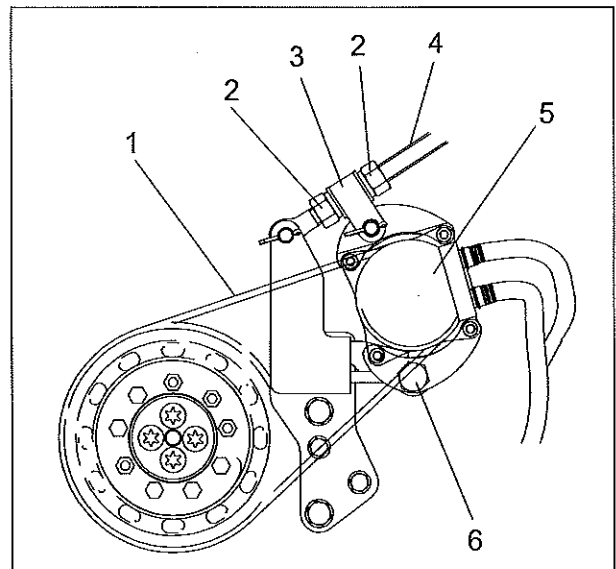

Fig.5-15

### Condenser

- Keep the condenser clean. Check its surface for oil dirt and mud. Check the cooling fin for bend or blockage.
- Use compressed air or water to clean the condenser to ensure good cooling performance of the condenser.
- During cleaning, avoid contacting the cooling fin and damaging the cooling pipes.

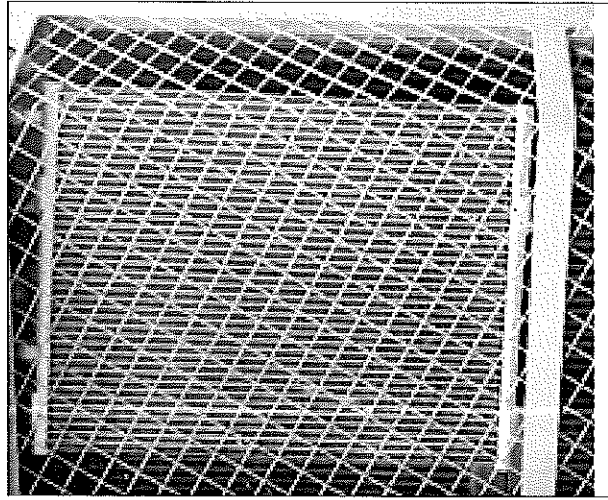

Fig.5-16

### Pipes

- Check all connectors, bolts and screws for looseness. Check if pipes contact with their surrounding components. Check if pipes are aged. Check if the rubber washer is damaged.

### Compressor

- During the seasons that the A/C may not be used, the A/C should be turned on every half a month and run for 5-10 minutes.
- Refrigerant cycle could bring cooling engine oil into the system, thus preventing poor sealing, leakage and sticking of refrigerant, and rust of parts.

## NOTICE

**Maintain the compressor at above 4 °C . Otherwise the viscosity of the refrigerant will be higher due to low temperature. Under this circumstance, parts can not be lubricated immediately after the compressor is started, thus causing wear and damage to the compressor.**

### 5.5.2.10 Hydraulic oil level

#### CAUTION

Hydraulic oil is hot and under pressure. Always wait for the machine to cool down. Failure to do so could result in possible injury.

---

The steps for checking the hydraulic oil level have been described. See: **Section 4.1.2.4 on page 4-4.**

### 5.5.2.11 Fuel level

The steps for checking fuel have been described. See: **Section 4.3.2 on page 4-10.**

### 5.5.2.12 Electrical system

#### (a). Battery

### ⚠ WARNING

Explosion hazard! When working on the batteries do not use open fire, do not smoke. There is a possibility of explosion.

### ⚠ CAUTION

Wear proper clothes to avoid skin from erosion by acid when filling acid to the batteries.

### NOTICE

Never leave tools on the batteries. Otherwise the batteries may become short circuit and the electric devices may be influenced.

- The batteries used in the roller are maintenance-free. You shall fix it on the roller firmly and check it frequently for looseness.
- To install the battery, coat the terminals with a little of vaseline and connect the wire to positive pole (+) first and then to negative pole (-).
- To take out the storage battery, disconnect the wire from negative pole (-) first and then from positive pole (+).

The following maintenance helps to prolong the service life:

- Turn off all consuming electrical appliances (such as ignition key switch, lamp, cab illumination lamp and radio).
- Check the battery open-circuit voltage regularly at least once a year.

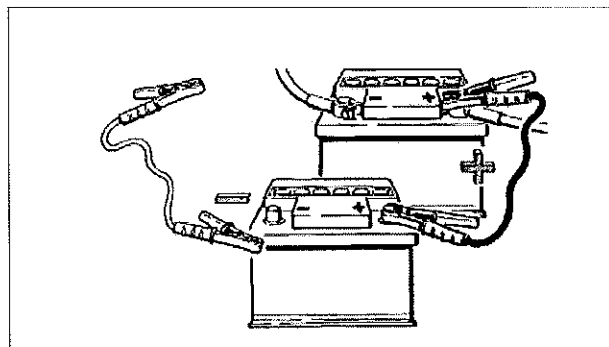

Fig.5-17

- When the voltage is 24V or less, recharge the battery at once instead of supercharging.
- Do not use battery in one hour after each charging.
- Disconnect the main switch if the machine is idle for 2 days. You'd better disconnect the main switch when you shut off the machine.
- Regular check the battery terminal for good connection isolation and anti-oxidation.
- Start the engine and charge the battery every 2 months if the machine is idle: Shut off the current consuming apparatus, increase the engine speed to over 1500rpm, charge the battery for over half an hour, and keep a record.
- Don't use electric equipment when the machine is not started; don't use too many current consuming apparatuses when the engine is idling or at low speed.

#### (b) Fuse

Check the fuse to see whether they are in good condition or not.

### NOTICE

**When replacing a new fuse, the capacity should be right. Otherwise it will melt again or not easy to melt when circuit is overloading. This will influence the electric system.**

**5.5.2.13 Oil/water spraying system**

- Check the screens of the fillers for the oil/water spraying system for cleanliness. If any dirt, clean them. If damaged, replace them.
- Check all connectors for leakage. If any, tighten them. If damaged, replace them.
- Check all filters connecting the lines for the system. If any dirt, clean them. If damaged, replace them.
- Check nozzles. If any dirt, clean them. If damaged, replace them.

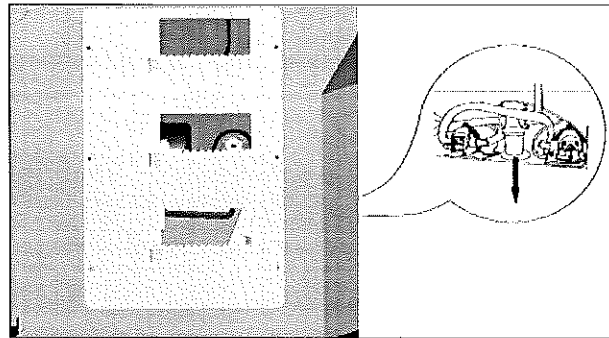

Fig.5-18

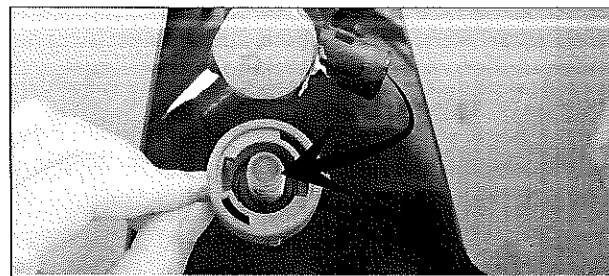

Fig.5-19

**5.5.2.14 Oil tank and oil lines**

Check the oil lines everyday and replace aged or damaged oil lines for normal working of the roller.

If any leaks are found in the oil tanks, do troubleshooting immediately. If welding needs to be performed, ensure to obey the safety instruction.

**⚠ WARNING**

- **When working on the fuel system, it is forbidden to smoke or use open fire or spill fuel, otherwise it has the potential of catching fire.**
- **Oil must be drained completely and dry the tank before welding it. Otherwise it will catch fire and cause danger to the personnel.**

**5.5.2.15 Oil leaks**

- Check under and around all sides of the roller.
- Check the pump, motor, multi-way valve, valve body, hose, flange and other connections for leakage.
- Check the engine for leakage.
- Check the A/C lines for leakage.

### 5.5.2.16 Drums and dampers

Steps for checking drums and dampers have been given. See: section 4.1.2.11 "Check the Vibratory Drum and Dampers" on page 4-7.

### 5.5.2.17 Connections and tightness

- Check and tighten bolts and nuts according to the tables above for looseness. If any damage, replace bolts and nuts of same or higher grade.
- Clean bolts and nuts before assembly. Lubricate bolts and nuts.
- Tightening torque is described with N•m:

For example: If you tighten nuts or bolts with 1m spanner and rotate the end of spanner with 120N force, 120N.m ( $1\text{m} \times 120\text{N} = 120\text{N} \cdot \text{m}$ ) will generate.

If the same force is required with 0.25m spanner, 480N force is required. ( $0.25\text{m} \cdot y = 120\text{N} \cdot \text{m}$ ,  $y = 120\text{N} \cdot \text{m} / 0.25\text{m} = 480\text{N}$ )

Table 5-9 Tightening torque value of bolts on main parts (N·m)

Grade	Nominal diameter (mm)						
	6	8	10	12	14	16	18
	Tightening torque value(N·m)						
8.8	10±1	25±3	50±5	90±10	145±10	235±15	310±20
10.9	14±1	33±3	75±6	123±10	195±10	300±15	415±30
12.9	18±2	45±5	90±10	150±10	245±15	350±20	520±35

Grade	Nominal diameter (mm)						
	20	22	24	27	30	36	
	Tightening torque value(N·m)						
8.8	410±30	600±40	760±50	1110±70	1510±120	2635±210	
10.9	570±35	800±50	1030±50	1525±120	1850±150	3075±250	
12.9	710±45	1030±50	1200±800	1875±150	2545±200	4445±355	

Table 5-10 Torque table for hoses, connectors and fillers (N·m)

Hose & 24° taper pipe connector		Filler		Filler	
Thread	Tightening torque	Thread	Tightening torque	Thread	Tightening torque
M14×1.5	30 (N·m)	M12×1.5	25 (N·m)	7/16-20	35 (N·m)
M16×1.5	45 (N·m)	M14×1.5	45 (N·m)	9/16-18	40 (N·m)
M22×1.5	70 (N·m)	M16×1.5	55 (N·m)	3/4-16	60 (N·m)
M26×1.5	105 (N·m)	M18×1.5	70 (N·m)	7/8-14	100 (N·m)
M30×2	135 (N·m)	M22×1.5	125 (N·m)	11/16-12	160 (N·m)
M36×2	160 (N·m)	M27×2	180 (N·m)	15/16-12	210 (N·m)
M45×2	290 (N·m)	M33×2	310 (N·m)	15/8-12	260 (N·m)
M52×2	330 (N·m)	M42×2	450 (N·m)		
		M48×2	540 (N·m)		

### 5.5.2.18 Washer

The steps for checking the washer and filling the detergent have been described. **See: Section 4.1.2.5 Check the Washer on page 4-5.**



### 5.5.3 Drain-Oil water separator

The check and water draining method for oil water separator has been introduced.

**See: Section 4.1.2.3 Check the Oil Water Separator on page 4-3.**

 **WARNING**

**Don't use open fire or smoking. There is a possibility of catching fire.**

---

## 5.6 Initial 50 Hour Maintenance

### NOTICE

Failure to perform the following procedures when and how directed will result in shortened service life of the machine or a system failure during operation.

#### 5.6.1 Securing machine for maintenance

1. Park the machine on a level flat surface, shut the engine down and remove the ignition key from the ignition key switch (1).
2. Set the parking brake switch (2) in the ON position.

**NOTE:** The parking brake indicator icon on the display will light up when the brake is set. See: Section 3.2.1 "Display and Switches" on page 3-19.

3. Follow the Lock-out/Tag-out procedure in the Safety section of this manual and always allow the systems time to cool down before proceeding with any service.

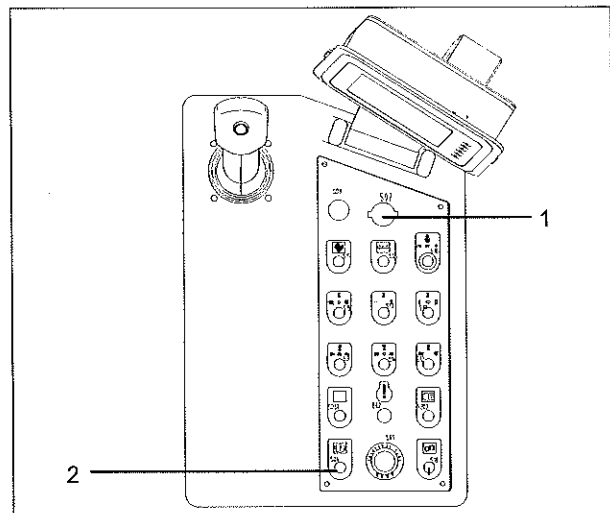

Fig.5-20

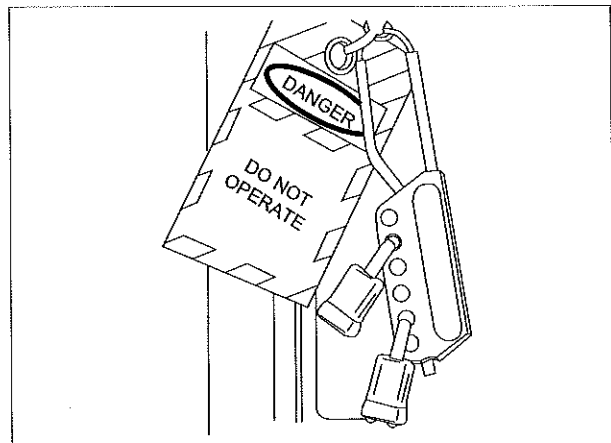

Fig.5-21

## 5.6.2 Change

### 5.6.2.1 Engine oil

The steps for checking and refilling engine oil have been described. See: Section 4.1.2.1 "Check the engine oil level" on page 4-2.

### NOTICE

**Never prolong the change interval of engine oil, or it will shorten the service life of engine due to corrosion, carbonization and wear.**

**NOTE:** When engine oil is replaced, the engine oil filter element should be replaced at the same time.

The following steps show how to change the engine oil.

1. Place the roller on even ground.
2. Start the engine for warm-up, and then shut down the engine.

**NOTE:** Change oil when it is hot. Under this circumstance, sediments in oil could be floated and would be drained out with oil.

### ⚠ CAUTION

**Protect yourself from the engine oil. Since its temperature is very high, and it will badly burned you if it spills onto your skin.**

### NOTICE

**Never start the engine when draining the engine oil. Otherwise it will cause damage to the engine.**

3. Turn the ignition key switch to the "0" position to stop the engine.

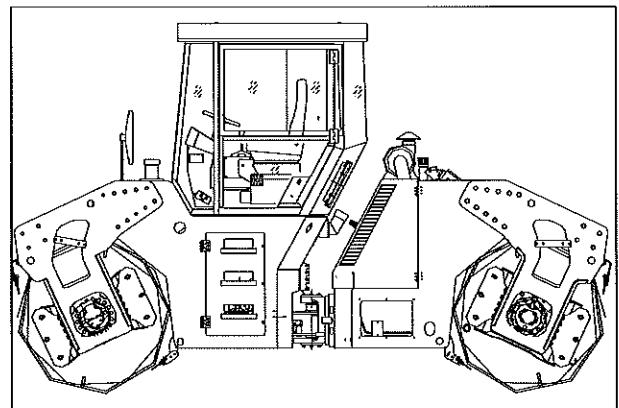

Fig.5-22

4. Place a vessel under the engine oil outlet close to the center articulation frame (1). Remove the plug to drain the engine oil.

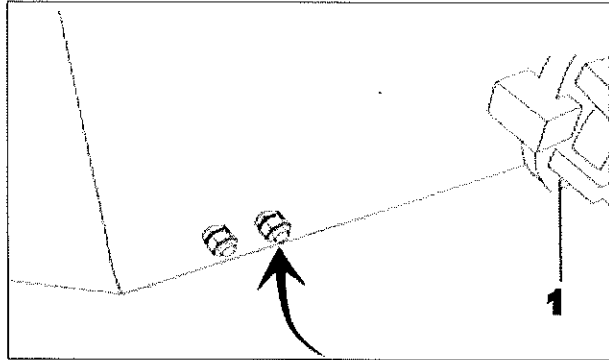

Fig.5-23

5. Screw the plug back. Then fill the appointed (See Table 5-8 on page 5-6) engine oil through the inlet.

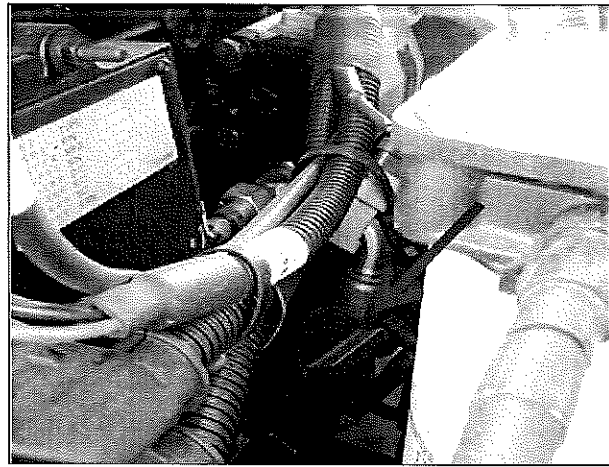

Fig.5-24

6. Start the engine and check the plug for leakage. If leakage appears, screw the plug again.
7. Shut down the engine. Wait until the engine cools down, then check the engine oil level. The steps have been given. **See: section 4.1.2.1 "Check the engine oil level" on page 4-2.**

### 5.6.2.2 Engine oil filter

The following steps show how to change the engine oil.

1. Thoroughly clean the outside of the filter.
2. Use a proper tool (belt spanner) to clamp the filter element.
3. Remove the filter element and collect the engine oil with a container.

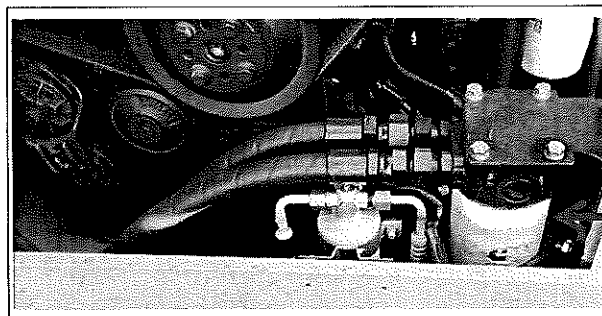

Fig.5-25

#### **⚠ WARNING**

**Protect yourself from the engine oil. Since its temperature is very high, and it will badly burn you if it spills onto your skin.**

#### **NOTICE**

**Never start the engine when the lube filter is removed. Otherwise engine oil will flow from the pipeline and make the engine lack of lubrication.**

4. Clean the sealing on the filter carrier from any dirt.
5. Slightly oil the rubber seal on the new filter.
6. Screw up the new filter element by hand until the seal contacts.
7. Tighten the filter element for another half turn.
8. Check the filter element for leak.

### 5.6.2.3 Fuel filter

## **⚠ WARNING**

Fire hazard! When working on the fuel system do not use open fire, do not smoke and do not spill any fuel. There is a possibility of catching fire.

## **NOTICE**

The engine must be shut down before changing the duplex fuel filter! Or insufficient fuel will be sucked into the engine, and it will cause the engine to work inefficiently or even shut down. This will shorten the service life of the engine.

Take the following steps to change the fuel filter:

1. Disassemble the filter with a special spanner and collect the fuel with a container, and then clean the filter.
2. Slightly oil the rubber seal on the new filter. Fill it with new fuel.
3. Screw up the new filter element by hand until the seal contacts.
4. Tighten the filter element for another half turn.
5. Release the air that possibly mixed in the fuel pipeline by pressing the manual pump up and down before starting the engine.
6. Check the filter element for leaks after a short test run.

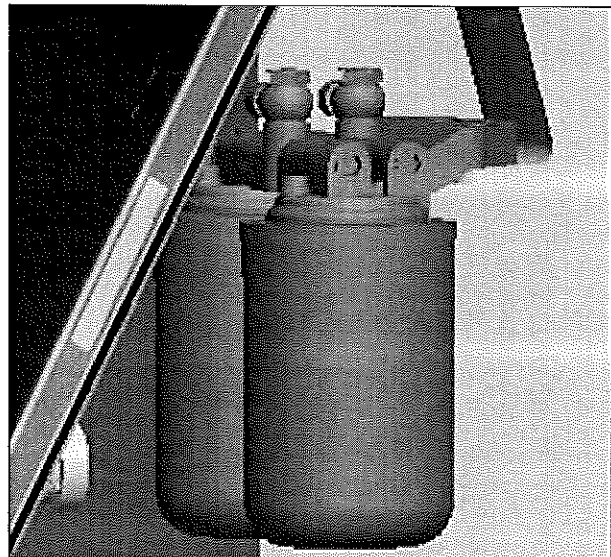

Fig.5-26

## 5.6.2.4 Oil water separator element

**⚠ WARNING**

Fire hazard! When working on the fuel system do not use open fire, do not smoke and do not spill any fuel. There is a possibility of catching fire.

**NOTICE**

The engine must be shut down before changing the oil water separator! Or insufficient fuel will be sucked into the engine, and it will cause the engine to work inefficiently or even shut down. This will shorten the service life of the engine.

Take the following steps to change the oil water separator.

1. Remove the cap of the oil water separator.
2. Clean the sealing on the filter carrier from any dirt.
3. Screw off the bowl.

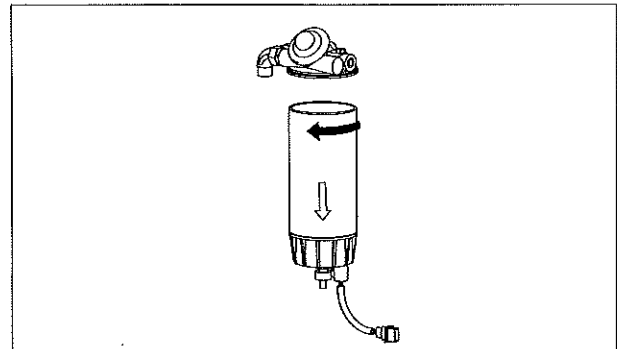

Fig.5-27

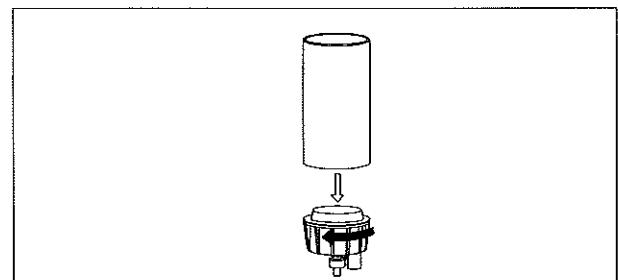

Fig.5-28

4. Apply a thin coat of oil to the rubber seal of the water separator (1).
5. Screw the water separator on by hand (2), until the seal contacts.
6. Tighten the water separator for another half (3).
7. Fill the filter element with clean fuel (4).
8. Apply some oil to the rubber seal of the filter element (5) and screw it on by hand, until the seal contacts.
9. Tighten the water separator for another half.

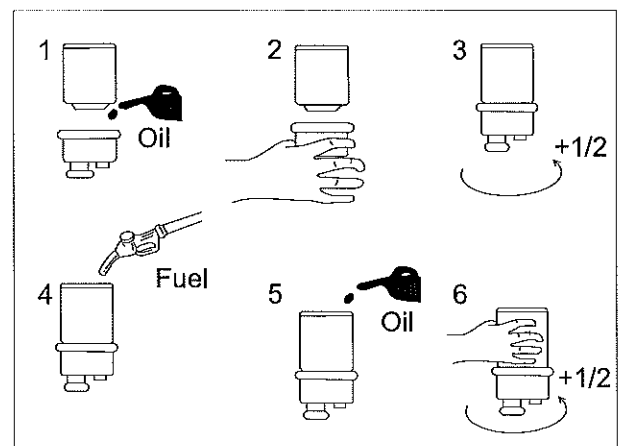

Fig.5-29

10. Release the air that possibly mixed in the fuel pipeline by pressing the manual pump up and down before starting the engine.

Steps for exhausting pipes:

- Loosen the bleed screw (A) on the oil water separator.
- Operate the manual pump (B) until fuel flows out from the bleed screw (A) without any bubble.
- Screw the bleed screw (A).

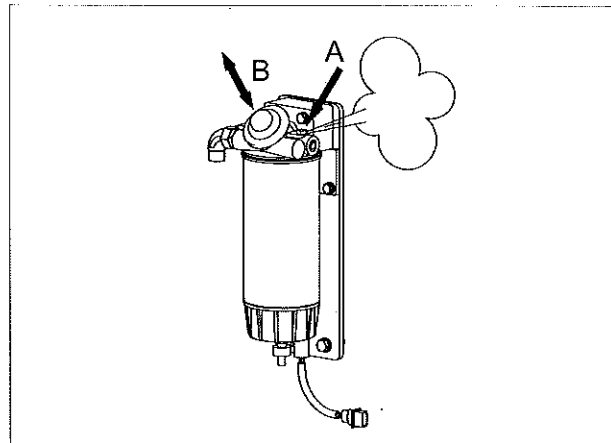

Fig.5-30

11. Check the filter cartridge for leaks after a short-time test run.

### 5.6.2.5 Lubricant for drums

Take the following step to change the lubricant in drums.

1. Place the roller on even ground.
2. Slightly move the roller to set the upper port on the bearing seat right above the shaft, the side port downwards and the lower port (A) at the lowest position.
3. Place a container under the lower port for used lubricant, and remove the oil drain plug, the oil level plug and the sealing washer to drain the lubricant in drums.
4. After lubricant is drained out, screw back the oil drain plug, the oil level plug and the sealing washer.
5. Remove the plug and the washer on the upper port (A) and the side port.
6. Add appointed lubricant (See Table 5-8 on page 5-12) till lubricant just flows out from the side port (B).
7. Clean the plugs. Screw and tighten them.

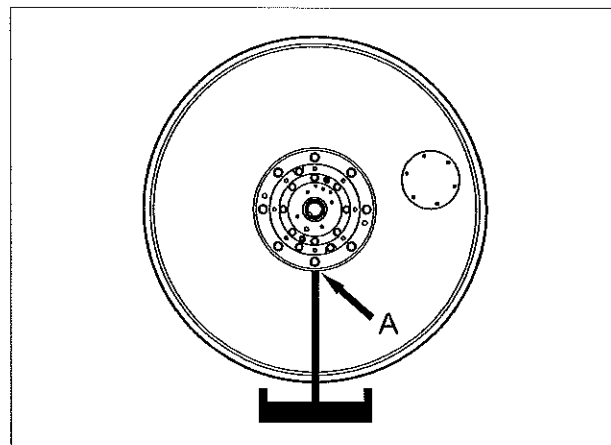

Fig.5-31

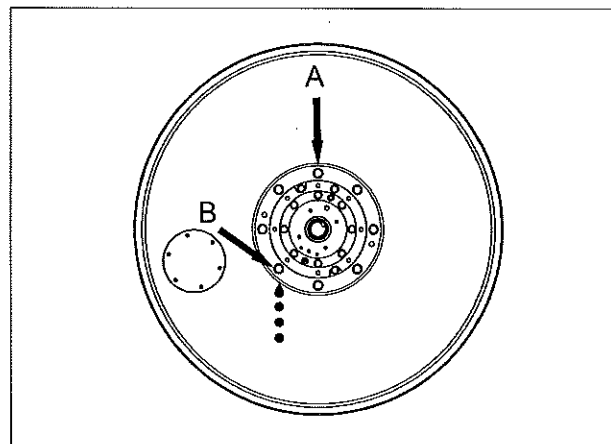

Fig.5-32



### 5.6.2.6 Lubricant for reducer

Take the following steps to change the lubricant for the reducer.

1. When draining the lubricant in the reducer, first make the outlet at the lowest position.
2. Place a vessel under the outlet. Remove the plug.
3. After draining the lubricant, screw the plug back tightly.

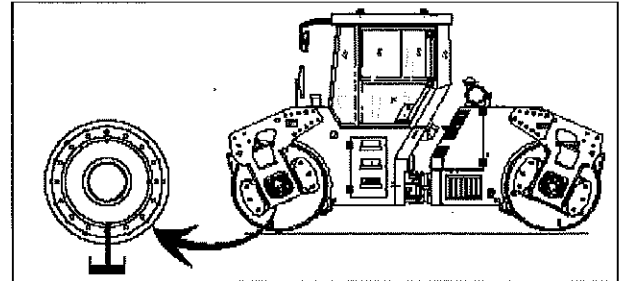

Fig.5-33

4. When adding lubricant to the reducer, first make the port (A) at the highest position.
5. Remove the plugs of port (A) and port (B).
6. Add appointed lubricant (**See Table 5-8 on page 5-12**) through inlet. When oil overflows from the port (B), then stop adding oil.
7. Screw the plugs back tightly.

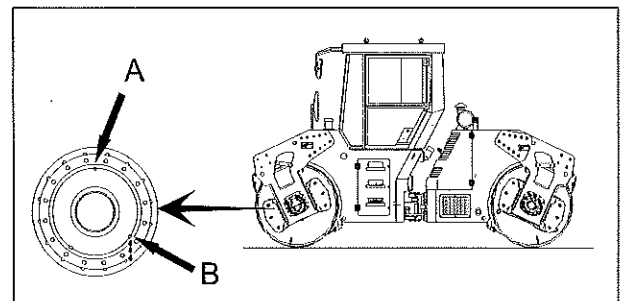

Fig.5-34

### 5.6.3 Check

#### 5.6.3.1 Engine belt

#### WARNING

**Work on the V-belt must only be performed with the engine shut down. Otherwise people will be badly hurt by the belts.**

Check the condition of the engine belt . If excessive wear happens, replace the engine belt at once.

#### NOTICE

**Use genuine belt parts and check them regularly.**

Methods and steps for checking the engine belt have been given. **See: section 5.5.2.8 "Engine belt" on page 5-23.**

#### 5.6.3.2 Compressor belt

#### WARNING

**Work on the V-belt must only be performed with the engine shut down. Otherwise people will be badly hurt by the belts.**

Methods and steps for checking the compressor belt have been given. **See: section 5.5.2.9 "A/C System" on page 5-25.**

## 5.7 Initial 250 Hour Maintenance

### NOTICE

Failure to perform the following procedures when and how directed will result in shortened service life of the machine or a system failure during operation.

#### 5.7.1 Securing machine for maintenance

1. Park the machine on a level flat surface, shut the engine down and remove the ignition key from the ignition key switch (1).

2. Set the parking brake switch (2) in the ON position.

**NOTE:** The parking brake indicator icon on the display will light up when the brake is set. See: Section 3.2.1 "Display and Switches" on page 3-19.

3. Follow the Lock-out Tag-out procedure in the Safety section of this manual and always allow the systems time to cool down before proceeding with any service.

For detailed information, see: Section 2.5.2 "Lockout/Tagout Procedures" on page 2-28.

**NOTE:** Obtain the maintenance record for this machine and complete it at the close of all maintenance procedures.

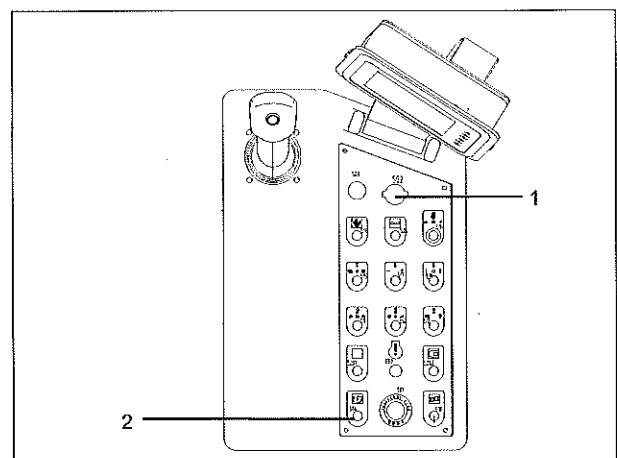

Fig.5-35

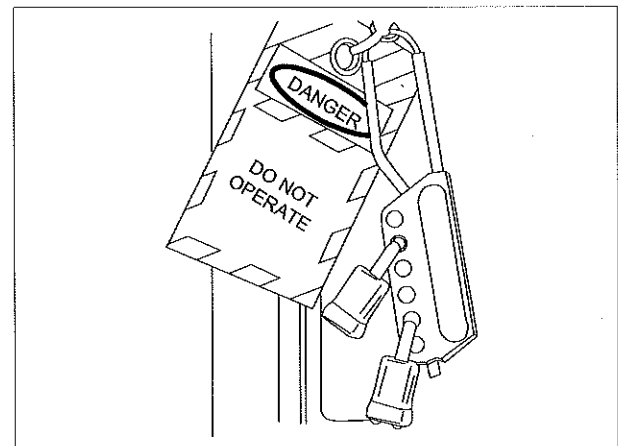

Fig.5-36

## 5.7.2 Replace

### 5.7.2.1 Lubricant for drums

Methods and steps for replacing the lubricant for drums have been given. **See: section 5.6.2.5 "Lubricant for Drums" on page 5-42.**

### 5.7.2.2 Lubricant for reducer

Methods and steps for replacing the lubricant for the reducer have been given. **See: section 5.6.2.6 "Lubricant for Reducer" on page 5-43.**

## 5.8 Initial 500 Hour Maintenance

### NOTICE

**Failure to perform the following procedures when and how directed will result in shortened service life of the machine or a system failure during operation.**

### 5.8.1 Securing machine for maintenance

1. Park the machine on a level flat surface, shut the engine down and remove the ignition key from the ignition key switch (1).
2. Set the parking brake switch (2) in the ON position.

**NOTE:** The parking brake indicator icon on the display will light up when the brake is set. **See: Section 3.2.1 "Display and Switches" on page 3-19.**

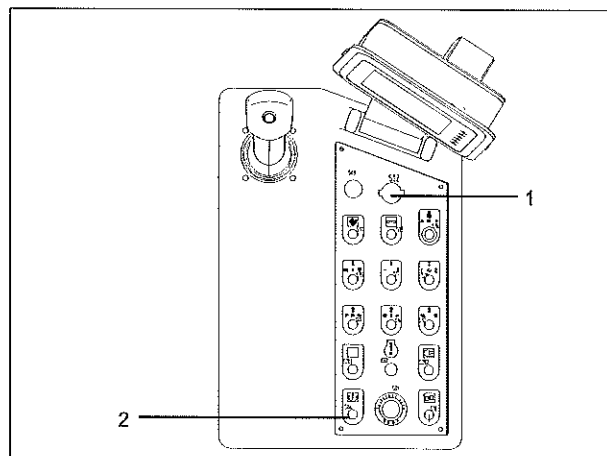

Fig.5-37

3. Follow the Lock-out Tag-out procedure in the Safety section of this manual and always allow the systems time to cool down before proceeding with any service.

### 5.8.2 Maintenance

- Repeat all the items of daily maintenance.

## 5.9 Every 250 Hour Maintenance

### NOTICE

**Failure to perform the following procedures when and how directed will result in shortened service life of the machine or a system failure during operation.**

With the roller secure proceed with the following items:

1. Repeat all the items of daily maintenance.
2. Replace:
  - Engine oil
  - Engine oil filter
  - Engine fuel filter
  - Oil water separator element

## 5.9.1 Replace

### 5.9.1.1 Engine oil

#### NOTICE

Never prolong the change interval of engine oil, or it will shorten the service life of engine due to corrosion, carbonization and wear.

#### ⚠ CAUTION

Protect yourself from the engine oil. Since its temperature is very high, and it will badly burn you if it spills onto your skin.

#### NOTICE

Never start the engine when draining the engine oil. Otherwise it will cause damage to the engine.

Each time you change engine oil, you should change engine oil filter element. Methods and steps for replacing the engine oil have been given. **See: section "Engine oil level" on page 5-22.**

### 5.9.1.2 Engine oil filter element

#### ⚠ CAUTION

Protect yourself from the engine oil. Since its temperature is very high, and it will badly burn you if it spills onto your skin.

#### NOTICE

Never start the engine after the engine oil filter element is removed, or the engine oil will flow out to cause lack of lubrication for the engine.

Methods and steps for replacing the engine oil filter element have been given. **See: section 5.6.2.2 "Engine oil filter" on page 5-37.**

### 5.9.1.3 Fuel filter

#### **WARNING**

Fire hazard! When working on the fuel system do not use open fire, do not smoke and do not spill any fuel. There is a possibility of catching fire.

#### **NOTICE**

The engine must be shut down before changing the oil water separator! Or insufficient fuel will be sucked into the engine, and it will cause the engine to work inefficiently or even shut down. This will shorten the service life of the engine.

Methods and steps for replacing the fuel filter have been given. See: section 5.6.2.3 "Fuel filter" on page 5-38.

**NOTE:** If the fuel filter is replaced or the roller is overhauled, the oil water separator element should be replaced at the same time.

### 5.9.1.4 Oil water separator element

#### **WARNING**

Fire hazard! When working on the fuel system do not use open fire, do not smoke and do not spill any fuel. There is a possibility of catching fire.

#### **NOTICE**

The engine must be shut down before changing the oil water separator! Or insufficient fuel will be sucked into the engine, and it will cause the engine to work inefficiently or even shut down. This will shorten the service life of the engine.

If the fuel filter is replaced or the roller is overhauled, the oil water separator element should be replaced at the same time. Methods and steps for replacing the oil water separator have been given. **See: section 5.6.2.4 "Oil water separator element" on page 5-39.**

## 5.10 Every 500 Hour Maintenance

### **NOTICE**

**Failure to perform the following procedures when and how directed will result in shortened service life of the machine or a system failure during operation.**

1. Perform the items in **Section 5.6.1 "Securing machine for maintenance" on page 5-34.**
2. Repeat all items in every 250 hour maintenance.
3. With the roller secure proceed with the following items:

Add:

- Lubraicant for propel bearing
- Lubraicant for center articulation
- Lubraicant for scraper chain

Replace:

- Air filter main element/safety element
- Lubricant for drums
- Lubricant for reducer

Check:

- Key welding parts, driving parts
- Damper



### 5.10.1 Add lubricant

#### Lubricant for propel bearing

Take the following step to add lubricant for the propel bearing:

1. Set the machine levelly.
2. Unscrew the plug (1) on the propel bearing seat.
3. Fill 2/3 of the bearing chamber with lithium base grease. Add appointed lubricant (**See Table 5-8 on page 5-12**) via the oil cup (2) on the bearing seat until oil flows out from the port for the plug (1).
4. Fit them back.

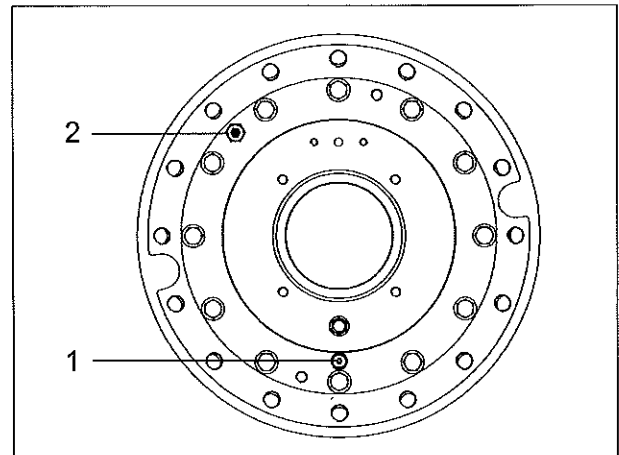

Fig.5-38

#### Lubricant for bearing of center articulation

Fill 2/3 of the bearing chamber with lithium base grease.

### 5.10.2 Replace

#### 5.10.2.1 Air filter main element/safety element

## NOTICE

**Maintenance work can be done only after the engine is shut down. Never start the engine after the air filter is removed. Otherwise dust will be drawn into the engine. And this will badly shorten the service life of the engine.**

- After the air filter main element has been maintained for three times, it should be replaced.
- Even if the maintenance of the main element has not up to 3 times and no alarm shows, the main element should be replaced after the roller has been worked for 500 hours.
- Replace the safety element instead of cleaning it. If the main element is replaced, it should be replaced at the same time.

### 5.10.2.2 Lubricant for drums

Methods and steps for replacing lubricant for drums have been given. **See: section 5.6.2.5 "Lubricant for Drums" on page 5-40.**

### 5.10.2.3 Lubricant for reducer

Methods and steps for replacing lubricant for reducer have been given. **See: section 5.6.2.6 "Lubricant for Reducer" on page 5-41.**

## 5.10.3 Check

### 5.10.3.1 Key welding parts, driving parts

- Check the frame and the drums for cracks. If any, repair them.
- Check the driving parts for deformation.
- Pay attention to the following points if welding repair is needed: painting protection and treatment of the roller; protection of electrical wires or hydraulic pipes; fire protection when working on fuel system.

### 5.10.3.2 Dampers

- Ensure the dampers are working in a state of compression.
- Check the dampers for cracks. If the length of any crack is more than 15mm, replace the damper.
- Check the dampers for elasticity. Replace any deformed or cracked damper. See Fig.5-48.

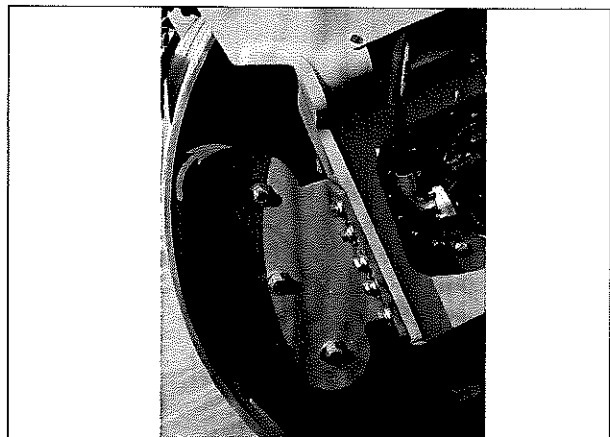

Fig.5-39

## 5.11 Every 1000 Hour Maintenance

### NOTICE

**Failure to perform the following procedures when and how directed will result in shortened service life of the machine or a system failure during operation.**

1. Perform the items in **Section 5.5.1 "Securing machine for maintenance" on page 5-34.**

1. Repeat all items in every 500 hour maintenance.
2. With the roller secure proceed with the following items:

Check/maintain:

- A/C system

Replace:

- Oil water separator element
- Hydraulic oil
- Hydraulic oil filter element
- Coolant

### 5.11.1 Check/maintain-A/C

In order to keep good performance, reliability and prolong the service life of the A/C, pay attention to the following items when using the A/C.

- Maintain the A/C according to the producer's instructions.
- Before turning on the A/C, first you have to start the engine. Wait a few minutes for the engine to work smoothly, then you can start the A/C and choose the proper fan speed and temperature.
- Close the window and doors when using the A/C. Save the energy.

- When exchanging the air without opening the window or doors, you can just turn on the fan speed control with the heat exchange valve closed.
- When cooling, the heat exchange valve should be closed.

Table 5-11 Check and Maintenance Intervals for A/C System

Item	Maintenance	Interval
Pipeline connector	Check the locking nuts for looseness; check the rubber hoses and connectors for refrigerant leak and oil stain; check the rubber hoses and pipes for crack, aging, embrittlement, damage by compression, and collapsing.	Once/month
Condenser	Check the fin for distortion and make it in order if any; check the core for blockage and clean it if any.	Once/month
	Check the fan for damage and abnormality.	Once/month
Evaporator	Clean the air-in/out ducts; check the bottom drain pipe for blockage and smoothen it if necessary	Once/year
Liquid storage	Check the pressure switch connector for looseness.	Once/quarter
	Replace the liquid storage after the A/C has been used for some time	Every 1000 h
Refrigerant volume	Check the refrigerant volume from the inspection window when the A/C runs. There shall be few or no air bubble; otherwise, add refrigerant.	Once/month
Compressor	Check the fastening bolts for looseness.	Once/month
	Check the fitting surface and the rotary shaft seal of main shaft for refrigerant leak and oil stain.	Once/month
	Check the compressor belt for wear and replace it if necessary.	Once/month
	Check the belt for tension and tension it if necessary.	Once/month
	Start and run the A/C for a few minutes in the seasons when the A/C is unused.	Once/month

- When the engine is shut down, the A/C should not be used for a long time. Because the batteries may be used up and will cause difficulty in the next engine startup.
- During the seasons that the A/C may not be used, the A/C should be turned on every half a month and run for 5-10 minutes.

## NOTICE

Daily cleaning should be done to keep the cooling capacity of the A/C in dusty conditions. Otherwise it will affect the performance of the A/C.

## NOTICE

Never use hot water for cleaning, which can lead to overpressure and damage the system.

### (a) Compressor

- Check and maintain it once every two years generally. Mainly check the inlet/discharge pressure and the fasteners for looseness and air leak.
- Disassemble the compressor to check the inlet/discharge valve for damage and distortion. If any, repair or replace the relevant valve.
- Replace the seal ring and shaft seal if the compressor is disassembled and repaired. Otherwise, it may cause leak at the compressor seal.

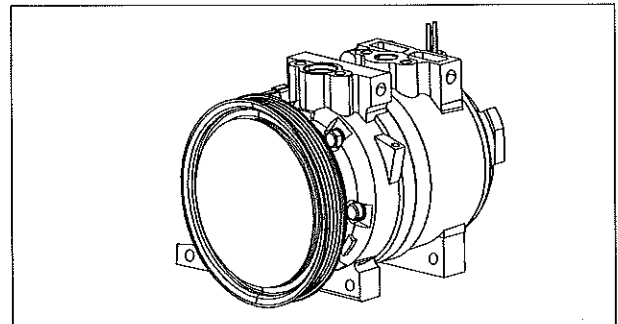

Fig.5-40

### (b) Condenser

The condenser is installed behind the radiator.

- Check and maintain them once a year generally. Clean the condenser plate with compressed air and cold water; rectify and repair the radiator gill by a pair of flat-nosed pliers; carefully check the condenser surface for abnormality; check for refrigerant leak with a leak detector.
- Recoat the antirust paint in case of peeling-off to prevent leak due to rusting and perforation.
- Check whether the cooling fan can normally run and whether the electric brush of fan motor is overly worn.

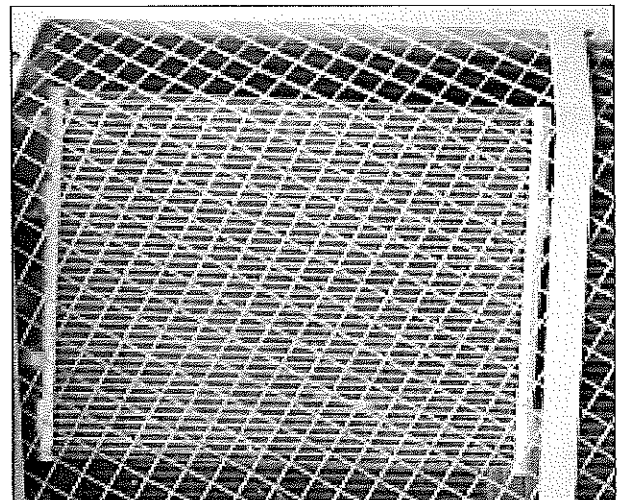

Fig.5-41

(c) Evaporator

- Generally, check it for leak with a leak detector once a year.
- Open it to clean the inner and the air duct once every 2~3 years.

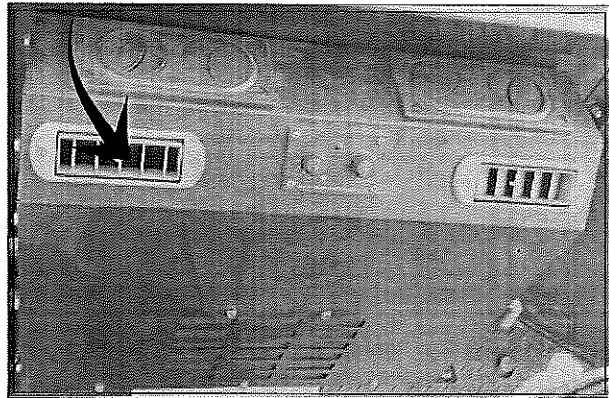

Fig.5-42

(d) Liquid storage drier

Refrigerant level checking procedures:

1. Start the engine.
2. Turn on the A/C for refrigeration. Turn on the temperature control switch to check if the air is cold.
3. Check the inspection window of the drier/collector to see if the white float is at the top.
  - If the white float is at the top, it is normal. See Fig.5-52.
  - If the white float is at the bottom, inform the service department. See Fig.5-53.

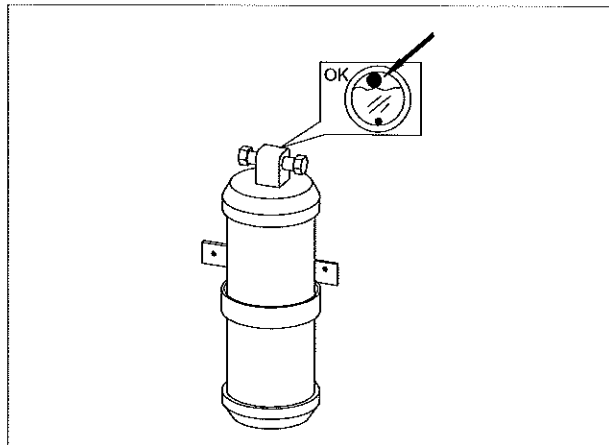

Fig.5-43

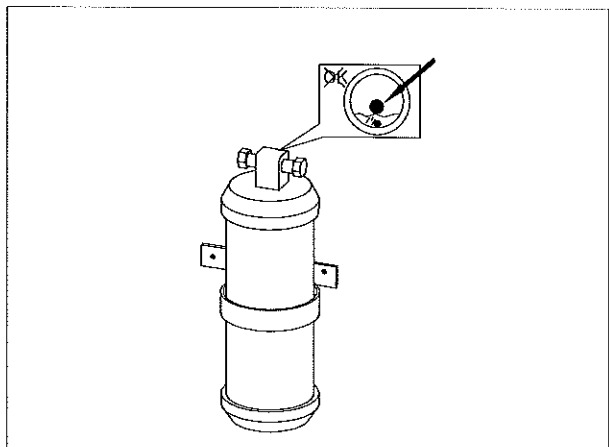

Fig.5-44

4. Fill the refrigerant. If necessary, check the A/C system for leakage.
5. Check the water indicator inside the inspection window of the drier/collector. See Fig.5-54.
  - Blue: normal drier.
  - Purple: too much water content.Inform the service department to replace the drier/collector. Check the A/C system.

### NOTICE

**Before yearly operation season, ask the service department to replace the drier/collector. Otherwise it will affect the performance of the A/C.**

### NOTICE

**In case of corrosion or mechanical damage, replace the drier/collector to avoid explosion and further damage.**

#### (e) Refrigeration pipeline

- Pipe connectors: Check them once every year, and check its sealing with a leak detector.
- Pipes: Check them for collision with other parts; check the rubber hoses for aging and crack. Replace the rubber hoses every 3~5 years.

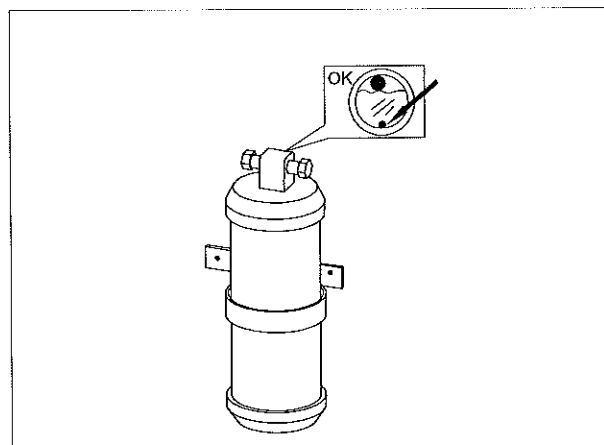

Fig.5-45

## 5.11.2 Replace

### 5.11.2.1 Hydraulic oil

Pay attention to the following items when changing the hydraulic oil.

#### **⚠ CAUTION**

**Protect yourself from the hot hydraulic oil. Since its temperature is very high, and it will badly burned your skin if it spills onto your skin.**

#### **NOTICE**

**Change the hydraulic oil under the working temperature. Otherwise some impurity may not be drained out with the hydraulic oil. After the hydraulic oil is drained, never start the engine. And they will cause great damage to the hydraulic element.**

#### **NOTICE**

**Except for the regular hydraulic oil change, replacement should be made as well after major repairs. Otherwise the hydraulic elements will be worn more easily.**

Replacing procedures:

1. Start the engine. Until the temperature of the hydraulic oil reaches to the working temperature, stop the engine.
2. Unscrew the plug of the drain port on the hydraulic oil tank to drain hydraulic oil. Place a vessel under the drain port.
3. Drain all hydraulic oil.
4. After draining the hydraulic oil, check the seal ring and replace it if necessary. Tighten it and the drain plug.

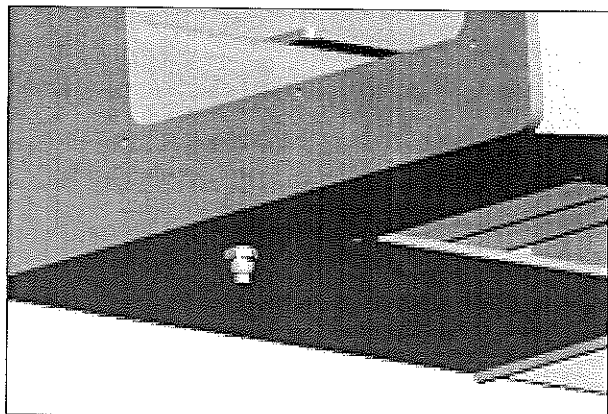

Fig.5-46



5. Take down the filter (B), add new appointed hydraulic oil (See Table 5-8 on page 5-12).
6. Refill oil to 1/2~2/3 of the level gauge scale. Observe the liquid level gauge (A).
7. Install the filler (B).
8. Start the engine and run it for 5 minutes. The oil level should be between the middle position and the Max position. If necessary, refill it.

**NOTE:** When the level of hydraulic oil is higher than the "H" level, open the plug of the drain port to drain it. When the level is up to 2/3 of the liquid level gauge, stop draining.

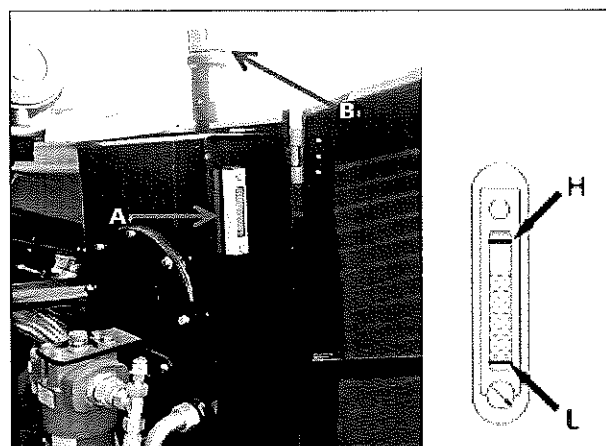

Fig.5-47

#### 5.11.2.2 Hydraulic oil filter element

### WARNING

Work on the hydraulic oil filter must only be performed with the engine cooled down. Otherwise people will be badly hurt by the hot hydraulic oil.

### NOTICE

Replace the hydraulic oil filter element every time when you change the hydraulic oil. Otherwise the hydraulic oil may be contaminated by the impurity on the old hydraulic oil filter.

Take the following steps to change the hydraulic oil filter.

1. Disassemble the filter with a special spanner.
2. Remove the filter element.
3. Apply some oil on the rubber seal on the new filter.
4. Screw up the new filter element by hand until the seal contacts.

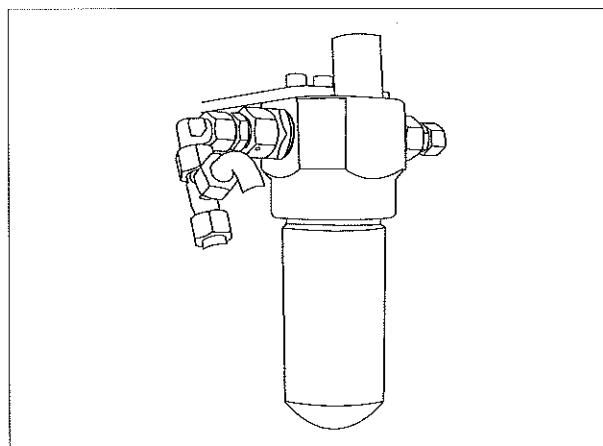

Fig.5-48

5. Tighten the filter element for another half turn.
6. Check the filter element for leaks after a short-time test run.

**NOTE:** Any visible dirt means potential faults of the hydraulic elements. Under this circumstance, do troubleshooting and replace or repair elements with potential faults. Ignoring these signs will cause complete damage to the hydraulic system.

Each time the hydraulic oil is replaced and an overhaul is performed on the hydraulic system, the filter element should be replaced.

### 5.11.2.3 Coolant

## NOTICE

**Check the coolant to prevent the engine from being damaged by corrosion, cavitations or freezing.**

Take the following steps to change the coolant:

1. If the temperature of coolant is lower than 50°C, unscrew the radiator cap.

## ⚠ CAUTION

**Never open the radiator cap when the coolant is very hot. Otherwise people could easily be burned by the hot coolant spilling from radiator.**

**Unscrew the cap slowly, and remove it after hot air is completely drained, to prevent being scalded.**

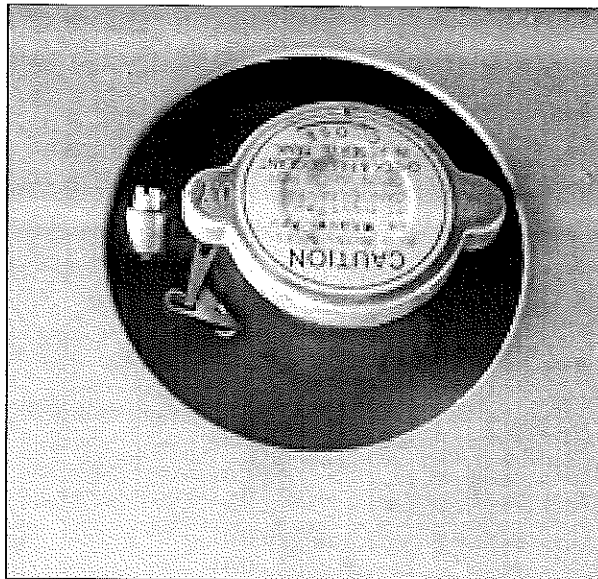

Fig.5-49

2. Place a vessel under the coolant outlet.  
Remove the plug on frame.

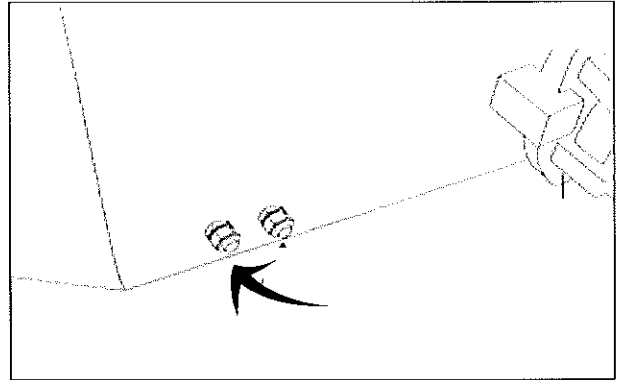

Fig.5-50

3. Screw the plug back. Then fill the new coolant (**See Table 5-8 on page 5-12**) through the inlet.
4. Screw the cap back.



Fig.5-51

5. Start the engine. When coolant temperature of the engine shown on the temperature gauge rises to 75°C-93°C, shut down the engine.
6. Wait until the engine cools down, then check the coolant level.

## 5.12 Other maintenance items

Perform the following maintenance items according to demands.

### 5.12.1 Clean the fuel tank

When you replace the hydraulic pump and the hydraulic motor or clean the hydraulic system, you shall clean the fuel tank. Take the following steps to clean the fuel tank.

1. Blow the outside of tank with compressed air to remove the dust. Remove the drain plug at the bottom of the tank to drain dirty fuel in the tank.
2. Open the cover on the top of the tank. Blow out the remaining oil and grain materials, esp., the blind corner, with compressed air.
3. Refill an appropriate amount of clean diesel oil (or kerosene) into the fuel tank. Use a new brush to clean the tank up and down. When the oil gets dirty, change it with new oil and continue cleaning till no dirt and sediment are found on the wall and bottom of tank.
4. Paste the wall and bottom of tank with dough. Never use cotton to clean them in order to avoid left fibre blocking pipelines. Carefully clean the fuel tank. Paste them with different doughs until no impurities can be seen on dough. After that, wash the fuel tank with new oil, blow the feul tank, and install the drain plug.

## NOTICE

**When filling, clean the filling pipe and oil tank port to prevent contamination. Close the oil tank port immediately after filling.**

**When filling, avoid swashing the oil bucket and don't insert the filling pipe into the bottom. Otherwise, impurities will be sucked into the fuel tank.**

### 5.12.2 Clean the radiator

#### **! WARNING**

Perform cleaning work only after the engine has cooled down and with the engine stopped. Otherwise people could easily be burned by the radiator.

- Check the radiator core daily and clean radiator core regularly. It is recommended to perform cleaning every 1000 working hours. When lots of sundries exist in the working site, shorten the cleaning interval by half.
- When the radiator cores are blocked, if the air from the air outlet of the radiator is relatively even (at rated speed) but the foreign substances are loosely adhered on the radiator, clean the foreign substances on the surface at first, and then repeatedly flush the air inlet and air outlet of the radiator by compressed air till all dust, weeds, insects and other foreign substances are blown off and the air from the air outlet is even. After that, the radiator may work normally. When the radiator cores are blocked, if the air from the air outlet of the radiator is mild (at rated speed) but the foreign substances are tight adhered on the radiator, remove the coolant radiator, hydraulic oil radiator, intercooler, and clean them alone.
- If the foreign substances are tightly adhered on the radiator, or you can't feel any air when you put your hand on the air outlet of the radiator (the engine is running at rated rotation speed), clean the radiator assembly, hydraulic oil radiator and engine coolant radiator separately, and then reassemble them.

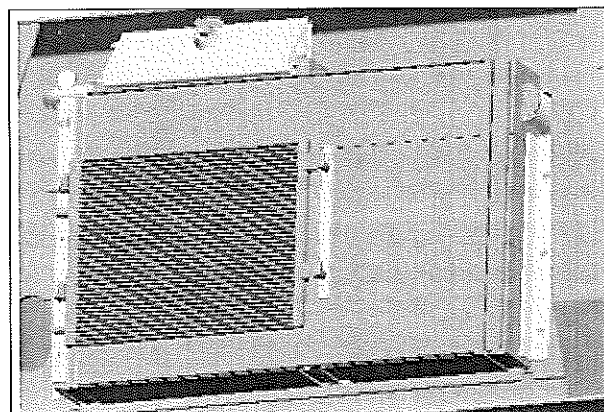

Fig.5-52

- When cleaning the radiator core (fins), the pressure of the compressed air should be not more than 0.2 MPa, the distance between the air outlet face and the radiator core should be not less than 50 mm, the pressure of the high pressure water should be not more than 0.27 MPa, and the distance between the high pressure water outlet face and the radiator core should be not less than 100 mm.
- During the cleaning process, do not spray water directly to the generator, cables and electrical parts. After cleaning, start the engine after the moisture is evaporated.

### **NOTICE**

**The engine must be shut down before changing the fuel! Or insufficient fuel will be sucked into the engine, and it will cause the engine to work inefficiently or even shut down. This will shorten the service life of the engine.**

### **NOTICE**

**The engine must be shut down before changing the oil water separator! Or insufficient fuel will be sucked into the engine, and it will cause the engine to work inefficiently or even shut down. This will shorten the service life of the engine.**

## 5.13 Maintenance for long-time storage

### 5.13.1 Engine

If the roller is to be stored for 3 months or even longer, maintain the engine in accordance with the following instructions:

- Use cold detergent, water gun or vapour cleaner to clean the engine and the cooling system.
- Run the engine, and then until the water on the surface of the engine evaporates stop the engine.
- Drain the coolant, and refill it after the antifreezing fluid is added.
- Drain the hot engine oil and add anticorrosive engine oil.
- Drain the fuel out of the fuel tank, and mix new fuel with anticorrosive engine oil (9:1), and refill the mixture into the fuel tank.
- Run the engine for 10 minutes to ensure all pipes, filters, pumps and nozzles are filled with the anticorrosive mixed oil.
- Rotate the engine crankshaft for several times without the engine starting, making the combustion chamber spraying the mixed oil.
- Remove the belts, and coat anticorrosive oil in the groove. and loosen belts of the AC generator, the cooling fan and the compressor. Clean out all anticorrosive oil before the engine restarts.
- Cover the inlet of the air filter and the outlet of the engine. Open the inlet and the outlet before the engine restarts.

### 5.13.2 The roller

If the roller is to be stored for 3 months or even longer, maintain it in accordance with the following instructions:

- Perform the maintenance for long-time storage and rust-proof treatment in accordance with the Engine User's Guide.
- Clean the inner and outer surfaces of the roller. Park it in the garage if available or at a ventilated place in the open air and cover it with canvas.
- Block up the front and rear frames in parallel. Adjust the adjusting pads until the damp blocks are not under stress. Connect and fix the front and rear frames with the limit plate.
- Lubricate the roller through each lubricating point.
- Clean the surface of vibratory drum. Wipe it with a piece of cloth and then coat some anti-rust paint. Apply anti-rust oil on the exposed machined parts of vibratory drum.
- Remove the storage battery and check the electrolyte level. Charge the battery once a month.
- Seal the air filter, dust port and exhaust pipe outlet with plastic or paper tape to keep the engine free of moist air.
- Fill up the fuel tank to avoid condensation and rust.
- Fill the hydraulic oil tank up to the mark "Max".
- Turn on/off the A/C for about 10 mins monthly.
- Turn on/off the heating system for about 10 mins monthly.



## 5.14 Antifreezing Maintenance

### NOTICE

**In cold weather, always drain the water from water spraying system and add antifreeze. Failure to do so may cause damage to the water spraying system. Pay attention to water pump, solenoid and filter which are easily damaged due to frost.**

- Dismount the water suction pipe before the filter in the water spraying system drain the water.
- Reconnect the water suction pipe properly.
- Add antifreezing coolant.
- Start the water spraying system to spray water until the antifreezing coolant is sprayed from the nozzle.
- After the ice period, drain the antifreezing coolant and dispose it in an environment-friendly way.

## 5.15 Check after Maintenance

After maintenance has been performed, check the following items for the roller:

1. Check when the roller is running:
  - Ensure the engine or the hydraulic system has no abnormal sound.
  - Check the maintained system for leakage.
  - Check the maintained system for any looseness or abnormal movement.
  - Check the maintained system for overheating.
2. Check when the roller stops:
  - Ensure all maintenance items and their steps have been performed.
  - Ask professional service personnel to check the correctness and completeness of maintenance on the roller.
  - Ensure all caps or plugs are reinstalled and tightened. Ensure all locks are locked.
  - Ensure no any tools, replaced parts, nuts, bolts are left in the machine.
  - If any elements in the hydraulic system are replaced or repaired, drain out air in the system before the roller restarts. Ensure there is no leakage in the system, and no distortion of pipes and hoses.
  - Fill the maintenacne record of the roller and put it back in place.





# SANY

## Troubleshooting

### 6 Troubleshooting

6.1 Mechanical Parts .....	6-1
6.1.1 Engine .....	6-1
6.1.2 Vibratory Drum .....	6-3
6.1.3 Propel system .....	6-4
6.1.4 Brake .....	6-5
6.2 Typical Hydraulic Elements .....	6-6
6.2.1 Axial Plunger Pump .....	6-6
6.2.2 Axial Plunger Motor .....	6-10
6.2.3 Change Valve .....	6-12
6.2.4 Overflow Valve .....	6-16
6.2.5 Steering Cylinder .....	6-20
6.2.6 Oil Filter .....	6-25
6.2.7 Sealing Elements .....	6-26
6.2.8 Hydraulic Steering Gear .....	6-28
6.3 Electrical Parts .....	6-30
6.3.1 Basic Electrical System .....	6-30
6.3.2 Electrical System of Working Devices .....	6-32
6.3.3 Fuses .....	6-33
6.3.4 Radio .....	6-34
6.4 Air Conditioning System .....	6-35
6.4.1 System with Poor Cooling .....	6-35
6.4.2 Insufficient System Cooling .....	6-36
6.4.3 Abnormal Noise Caused by Cooling System .....	6-38
6.4.4 Air Heating Device Fault .....	6-39
6.4.5 Other Faults .....	6-39

6.5 Troubleshooting Examples ..... 6-41

**⚠ WARNING**

**Read and understand all safety precautions and instructions in this manual before reading any other manuals provided with this roller and before operating or servicing the roller. Failure to do this can cause property damage, personal injury or death.**

## 6 TROUBLESHOOTING

### 6.1 Mechanical Part

#### 6.1.1 Engine

Table 6-1 Fault Analysis and Troubleshooting for Engine

Fault Symptom	Cause	Remedy
Engine can not be started	Fuel used up	Fill up fuel and bleed system.
	Fuel filter blocked	Replace filter.
	Leakage of fuel pipe	Check and tighten all connections.
	Discharge or poor connection of storage battery	Clamp polar clamp and check cables.
Difficult startup or unstable working power of engine	Slow starter rotation speed due to too low voltage, loose or oxidized polar clamps of storage battery	Check storage battery and clean, reconnect and grease polar clamps.
	Engine oil with excessive viscosity, especially in winter	Use appropriate engine oil.
	Unsmooth fuel supply; block in fuel system caused by the paraffin in winter	Replace fuel filter, check all oil pipes and use the winter-grade diesel when it turns cold.
	Incorrect valve clearance	Adjust valve clearance.
	Nozzle with defects	Check by the expert.
	Turbocharger with defects	Check by the expert.
	Dirty air filter	Clean or replace air filter.
	Defective vacuum switch	Check vacuum switch.
Too much smoke discharged	Too tight throttle cable	Adjust or replace throttle cable.
	Too much engine oil	Drain redundant engine oil.
	Dirty air filter	Clean or replace air filter.
	Insufficient compression due to burnt or broken piston	Check by the expert.
Engine too hot or shut down suddenly	Incorrect valve clearance	Adjust valve clearance.
	Cylinder or cooling fin of radiator at the top of cylinder blocked by dirt	Clean cooling fin of the radiator, esp. the vertical fin at the top of cylinder.
	Nozzle with defects	Check by the expert.
	Incorrect adjustment of piston pump	Check by the expert.
	Limited cooling airflow	Clean cooling air conveying pipe.
	Loose or broken fan belt	Adjust or replace fan belt.

Fault Symptom	Cause	Remedy
Too low oil pressure	Too much oil consumption or less engine oil	Fill up engine oil, immediately shut down the equipment and find out the causes, and check oil filter or cooler for leakage.
Charging alarm indicator of storage battery lit on during operation	Too low engine speed	Check, adjust or replace the belt.
	Fault in generator or adjuster, and no charge of storage battery	Check by the expert.
Insufficient power of engine	Too much engine oil	Discharge redundant engine oil.
	Dirty air filter	Clean or replace air filter.
	Turbocharger with defects	Check by the expert.
	Leakage of pressure tube	Check and tighten screws and nuts on pressure tube.
	Incorrect valve clearance	Adjust valve clearance.
	Nozzle with defects	Check by the expert.
Crankshaft rotates slowly and can not be started	Loose and eroded wiring of battery	Clean and tighten the wiring.
	Insufficient voltage of storage battery	Charge storage battery.
	Incorrect lubricant model	Change it with the lubricant of specified grade.
Crankshaft rotates normally but can not be started	No fuel supply of oil injector	Check oil injector and high-pressure lines.
	Failure of fuel cutoff solenoid	Check the resistance of solenoid.
	No fuel supply of oil injection pump	Check the low-pressure oil circuit and fuel tank.
	Abnormal operation of preheating system	Check preheating system.
	Defective preheating plug	Replace preheating plug.
	Leakage of oil injection tube	Retighten adaptor or replace fuel tube.
	Improper oil injection timing	Adjust oil injection timing.
	Damaged oil injector or its seat	Repair or replace oil injector or its seat.
Unstable idling	Improper adjustment of throttle cable	Adjust throttle cable.
	Too low idling speed	Readjust idling speed.
	Fuel leakage	Check, tighten or repair the leaked part.
	Improper oil injection timing	Adjust oil injection timing.
	Damage or abnormal operation of oil injector or oil supply valve	Check, adjust or replace oil injection pump or oil supply valve.
	Insufficient oil supply of oil injection pump	Check and adjust it.



## 6.1.2 Vibratory drum

Table 6-2 Fault Analysis and Troubleshooting for Vibratory Drum

Fault Symptom	Cause	Remedy
Vibration at only one position of vibration switch	Broken circuit from vibration switch to vibration pump control solenoid	Check circuit and reconnect broken point.
No vibration or small vibration at both positions of vibration switch	Broken circuit from vibration switch to vibration pump control solenoid	Check circuit and reconnect broken point.
	Damaged coupling	If the circuit and solenoid are normal, remove the vibratory motor from the vibratory drum (not including the oil pipe) to check the coupling for damage. If any, replace it.
	Heavy internal wear in hydraulic pump	Check for heavy internal wear. If necessary, ask professional personnel for repair.
	Heavy internal wear in hydraulic motor	Check for heavy internal wear. If necessary, ask professional personnel for repair.
	Incorrect position of vibration switch	Set switch to position I.
Air in hydraulic system	Insufficient oil in hydraulic oil tank	Check oil level and refill new oil.
	Oil suction tube not sealed	Check oil-suction tube and tighten connecting elements.
Poor compaction or machine jittering during vibration	Engine working abnormally due to insufficient power	Check engine.
	Heavy internal wear in hydraulic pump	Check for heavy internal wear. If necessary, ask professional personnel for repair.
	Heavy internal wear in hydraulic motor	Check for heavy internal wear. If necessary, ask professional personnel for repair.

Fault Symptom	Cause	Remedy
Abnormal vibration frequency	Faults in vibratory hydraulic system (e.g., low efficiency, oil leakage and improper pressure)	Check and rectify faults.
	Too much or too less oil in oil chamber of eccentric block	Check oil chamber, and drain or fill oil.
	Improper throttle control mechanism	Check and adjust
	Improper engine speed	Set to a proper engine speed.
	Change in oil pump output	Adjust limit screw.

### 6.1.3 Propel system

Table 6-3 Fault Analysis and Troubleshooting for Propel System

Fault Symptom	Cause	Remedy
Powerless traveling	Insufficient engine power	Check and repair engine.
	Wear in hydraulic pump and hydraulic motor	Rectify by professional personnel.
Air in hydraulic system	Insufficient oil in hydraulic oil tank	Check oil level and refill new oil.
	Oil-suction tube not sealed	Check oil-suction tube and tighten connecting elements.
Normal forwarding, but powerless reversing	Failed control valve in pump	Rectify by professional personnel.
Failed parking brake	Heavily worn or damaged brake lining	Adjust brake lining clearance or replace brake lining by professional personnel.
Abnormal traveling speed	Loose throttle control mechanism	Re-adjust
	Improper engine speed	Set to a proper engine speed.
Large impact in transmission system or torpid steering	Heavily worn bearing	Replace
	Insufficient lubricating grease	Fill grease.
No traveling	Damaged pressure relay	Replace
	Damaged emergency brake solenoid	Replace
	Defective circuit	Repair or replace
Difficult traveling	Damaged brake solenoid	Repair or replace
	Damaged reducer	Replace

## 6.1.4 Brake

Table 6-4 Fault Analysis and Troubleshooting for Brake

Fault Symptom	Cause	Remedy
Insufficient braking force	Brake disc misadjusted	Check the thickness of brake disc; adjust the clearance of brake disc if the brake disc is not heavily worn.
	Heavily worn brake disc	Check the thickness of brake disc, and replace the brake disc if the brake disc is heavily worn.
Overheating of brake	Improper oil level	Check oil level, and fill or drain oil to a proper oil level.
	Small clearance of brake disc	Adjust brake disc clearance.
	Improper lubricant	Drain off oil, and fill the proper one instead.

## 6.2 Typical Hydraulic Elements

This section describes the common faults and the relevant remedies of typical hydraulic elements.

### 6.2.1 Axial plunger pump

Table 6-5 Fault Analysis and Troubleshooting for Axial Plunger Pump

Fault Symptom	Cause	Remedy
Insufficient oil discharging or sluggish action of actuator	Blocked oil suction pipe and oil filter or great resistance	Unblock oil pipe and clean oil filter.
	Low oil level in oil tank	Check oil level and fill oil.
	Air in pump body (not filled up with oil)	Bleed pump (filling oil into pump).
	Wear between plunger and cylinder hole, or between oil distributor and cylinder body	Replace plunger, grind the contact face between oil distributor and cylinder body, and ensure good contact.
	No seal between cylinder body and oil distributor, because plunger returns incompletely or can not return due to broken center spring	Check and replace center spring.
	Failure of variable mechanism failing to meet the working requirements	Check variable mechanism: check whether variable piston or variable mechanism is agile, and correct their adjustment error.
	Internal leak or difficult oil suction due to improper oil temperature or air suction of hydraulic pump	Select suitable oils according to the actual condition of temperature rise and fix the joint where the air leak may occur.

Fault Symptom	Cause	Remedy
Insufficient pressure or strong pressure pulse	Blocked oil suction port or narrow oil passage	Unblock oil suction port and widen the cross section for oil passage.
	High oil temperature, low oil viscosity and more internal leak	Control oil temperature, and change oil with new one of greater viscosity.
	Large internal leak due to wear between cylinder body and oil distributor, or between plunger and cylinder hole	Trim the contact face between cylinder body and oil distributor, and replace the plunger. In case of heavy wear, sent them to the factory for repair.
	Small flow as a result of small deflection angle of variable mechanism	Widen deflection angle of variable mechanism.
	Increasing internal leak due to fatigued center spring	Replace center spring.
	Incoordination of variable mechanism (e.g., large pulse due to incoordination between servo piston and variable piston.)	For occasional pulsations, change oil; for frequent pulsations, remove and repair the mating elements, as whose damage or incoordination is likely to cause such pulse.
Excessively loud noise	Air in pump	Bleed pump and check the part into which the air may enter.
	Bearing improperly assembled, or abraded or damaged at one side	Check bearing for damage, and replace it in time.
	Difficult oil suction due to blocked oil filter	Clean oil filter.
	Dirty oil	Check oil by sampling and change it with clean oil.
	Large oil suction resistance due to high oil viscosity	Change it with oil of lower viscosity.
	Low oil level or air suction in hydraulic pump	Fill oil to the specified level and check the sealing.
	Pump not fitted concentrically with motor, which increases the axial load	Readjust them to the allowable range.
	Lines vibrate; connector between plunger and ball head of sliding boot seriously loosen or flaking off	Take measures for insulation and vibration absorption. Check, repair or replace components.

Fault Symptom	Cause	Remedy
Internal leak	Wear between cylinder body and oil distributor	Trim contact face.
	No seal between cylinder body and oil distributor due to damaged center spring	Replace center spring.
	Large axial clearance	Adjust axial clearance to specified value.
	Wear between plunger and cylinder hole	Replace plunger and regrind the contact face.
	Internal leak due to low oil viscosity	Change it with oil of proper viscosity.
External leak	Damaged seal on drive shaft	Replace seal ring.
	Nuts and bolts on joint surfaces and pipe connectors not tightened, and seal damaged	Tighten them and check and replace the seal.
Too hot hydraulic pump	Serious internal leak	Check and grind relevant seal surfaces.
	Serious air suction in hydraulic pump	Check and seal relevant sealing parts.
	Wear in matching contact faces (e.g. between cylinder body and oil distributor, or between sliding boot and swashplate)	Trim or replace the worn parts, such as oil distributor and sliding boot.
	High oil viscosity, small capacity of oil tank, or high rotation speed of hydraulic pump	Change oil, increase capacity of oil tank or set a cooling device, or lower rotation speed.
Fault of variable mechanism	Blockage in control oil circuit	Filter oil, and flush oil circuit (if necessary).
	Wear between variable piston and variable shell	Trim, grind, or replace them.
	Servo piston, variable piston and spring element shaft get stuck	For the mechanical seizure, grind moving parts; change dirty oil.
	Spring on one-way valve in the control oil circuit damaged	Replace dirty oil; change oil of low viscosity if the oil temperature is too low.

Fault Symptom	Cause	Remedy
No rotation (i.e. seizure) of pump	Seizure of plunger and cylinder hole as a result of dirty oil, the change in oil temperature, or the adhesion due to high temperature	Change dirty oil; in the event of too low oil temperature, change oil with new one of lower viscosity; or use a scrapper to scrape away the metal crumbs.
	Sliding boot flaking off due to stuck or flaked off plunger or loaded startup	Replace or refit sliding boot.
	Broken plunger ball due to stuck plunger or loaded startup	Replace plunger ball.

6.2.2 Axial plunger motor

Table 6-6 Fault Analysis and Troubleshooting for Axial Plunger Motor

Fault Symptom	Cause	Remedy
Low rotation speed and small torque	Insufficient oil supply of hydraulic pump	Try to improve oil supply condition.
	Low rotation speed of motor	Find out the causes and carry out adjustment.
	Blocked filtration screen of oil filter	Clean or replace filter core.
	Difficult oil suction due to insufficient oil in oil tank or small pipe diameter	Fill oil, and properly increase pipe diameter to ensure smooth oil suction.
	Internal air leak due to poor seal	Tighten relevant joints, and properly increase pipe diameter to ensure smooth oil suction.
	High oil viscosity	Change oil with new one of lower viscosity.
	Large axial and radial clearances, great leak volume, and low volumetric efficiency	Repair hydraulic pump.
	Insufficient input pressure of hydraulic pump	Try to increase the pressure.
	Low efficiency of hydraulic pump	Check and rectify the fault of hydraulic pump.
	Insufficient adjusting pressure or failure in overflow valve	Check and rectify the fault of overflow valve, and increase the pressure.
	Slender line and great resistance	Increase diameter of line and adjust the layout.
	High oil temperature, low oil viscosity, and more internal leak	Check causes for oil temperature rise, cool down oil and change oil with new one of higher viscosity.
	Serious leaks on joint surfaces of hydraulic motor	Tighten connecting bolts on each joint surface and check the sealing condition.
Serious leak due to heavily worn internal hydraulic elements	Check damaged parts, and grind or replace these elements.	



Fault Symptom	Cause		Remedy
Leak	Internal leak	Large axial clearance due to wear in end faces of oil distributor and cylinder body	Grind end faces of oil distributor and cylinder body.
		Fatigued spring	Replace spring.
		Heavy wear between plunger and cylinder hole	Grind cylinder hole and refit plunger.
	External leak	Poor seal at shaft end or damaged seal ring	Replace seal ring.
		Bolts on joint surfaces and pipe connectors loosen or not tightened	Tighten the bolts and pipe connectors at relevant connecting positions.
Abnormal noise	Bearing improperly fitted or worn out		Refit or replace bearing.
	Air in pump due to poor seal		Check seal of air inlets and tighten connecting parts.
	Dirty oil or air bubble in oil		Change it with clean oil.
	Coupling not concentric		Calibrate its concentricity.
	High oil viscosity		Change oil with new one of lower viscosity.
	Heavy wear at radial side of hydraulic motor		Grind cylinder hole and refit plunger.
	External vibration		Take measures (e.g. adding an insulating cover) to insulate the external vibration source.

6.2.3 Change valve

Table 6-7 Fault Analysis and Troubleshooting for Change Valve

Fault Symptom	Cause	Remedy	
No switch	Valve core stuck due to oil port of electromagnetic change valve not connected to oil return tank or high counter pressure in oil drain pipeline	Check, connect oil port to oil return tank, and reduce counter pressure.	
	Electromagnetic change valve affected by gravity of parts such as valve core and armature caused by its vertical installation	Install electromagnetic change valve with its axis in horizontal position.	
	Seizure of slide valve	Valve core stuck in hole and not acting or acting torpidly due to small clearance between slide valve (valve core) and valve body	Check clearance and repair or replace valve core.
		Axial hydraulic seizure due to valve core (or valve body) bruised, or stuck by dirt or particles	Check, grind or refit valve core. Change oil with new one, if necessary.
		Axial hydraulic seizure due to geometric over-deviation in opening and closing of valve core or non-concentricity of valve core and valve hole	Check and correct geometric over-deviation and non-concentricity.
		Valve core stuck due to distorted valve body or valve core	Refit, tighten and overhaul valve body and valve core.
	Fault of electromagnet	Insufficient power for electromagnet to propel the valve core due to low supply voltage	Check supply voltage and make it as per requirements (i.e. within +10% ~ -15% of the specified voltage).
		AC electromagnet burnt out as a result of electromagnet element not attracted to the end due to blocked slide valve.	Rectify the stuck slide valve and replace electromagnet.
Difficult to propel the valve core as a result of insufficient attraction due to magnetic leak		Find out the causes for magnetic leak and replace electromagnet.	

Fault Symptom	Cause		Remedy
No switch	Fault on control oil circuit of hydraulic change valve	Low pressure of hydraulic control oil to propel valve core	Increase control pressure, check whether the spring is too rigid, and replace spring (if necessary).
		Throttle valve on the hydraulic change valve closed or blocked	Check, adjust and clean throttle orifice.
		Oil ports at both ends of hydraulic slide valve not connected with oil return tank, or oil drain pipe blocked	Check and connect oil ports with oil return tank, and clean and unblock oil return pipe.
		Slide valve can not switch or reset due to broken, omitted, or too soft spring	Check, replace or fit spring.
Lower action speed of actuator than specified one	Insufficient stroke of valve core, lower opening of valve and small flow, which are resulted by the shortened switch push rod (as a result of abrasion due to long-term knocking), or the worn contact point of armature		Replace push rod or electromagnet.
Oil leak at the push rod of dry electromagnet change valve	Oil leak due to heavy wear at seal ring of push rod		Replace seal ring.
	Oil leaking at push rod due to large counter pressure at oil drain (oil return) chambers at both ends of solenoid		If the counter pressure is too high, respectively connect these chambers to the oil return tank.
Sluggish attracting and releasing of wet electromagnet change valve	There are two sealing screws at the rear end of electromagnet, and the air enters into the rear chamber during the initial installation of these screws.		Screw off these sealing screws, fill sufficient oil, and then screw down the screws for sealing.
Oil leak at the joint surfaces of plate change valve	Loose mounting screw		Tighten mounting screw.
	Poor processing precision of surface of bottom mounting plate		Trim the surface of bottom mounting plate to get a good precision.
	Seal ring for bottom face aged or of poor sealing effect		Replace seal ring.
	Screw made of material not as per requirements, thus screw distorted after being stretched		Replace and tighten screw in accordance with requirements.

Fault Symptom	Cause	Remedy
Overheating or burnout of electromagnet	Overheating of coil due to supply voltage higher than the specified value	Check supply voltage, and make it as per requirements (i.e. within +10% ~ -15% of the specified voltage).
	Poor insulation of electromagnetic coil	Use wet DC electromagnetic coil.
	Overheating of coil due to frequent switch	Check and refit coil.
	Poor contact due to defective welding of wires	Remove and refit wires.
	Electromagnet element not concentric with the axis line of slide valve.	Replace electromagnet.
	Overheating and burnout of coil due to large current as a result of failure to attract the electromagnet element, which is caused by the length of push rod not in proportion to the stroke of electromagnet	Repair push rod.
	Burnout of coil due to oil entering dry electromagnet	Check and rectify the fault of oil leak at push rod, or replace seal ring.
Torpido switch	Slide valve stuck by dirt in oil	Clean slide valve and change oil.
	Large or small force of spring	Replace spring with a proper one.
	Dirt at the contact part of electromagnetic element.	Remove dirt.
	Large or small clearance between slide valve and valve body	Face up or replace slide valve.
	Incomplete or torpid steering due to short movement of valve core as a result of insufficient length or incorrect stroke of worn push rod of electromagnet	Check and repair push rod, or replace it (if necessary).

Fault Symptom	Cause	Remedy
Impact and noise during switch	Rapid movement of slide valve of hydraulic change valve	Diminish the orifice of one-way throttle valve on hydraulic change valve, and slow down the movement of slide valve.
	Large fitting clearance between hole and element of one-way throttle valve (on the hydraulic change valve), omitted installation of spring for one-way valve and ineffective resistance	Check and adjust the clearance to a proper value and fit a spring.
	Uneven contact face or poor contact of electromagnet element	Remove foreign materials, and repair electromagnetic element.
	Vibration of piping and other elements due to hydraulic impact (the two circuits with great pressure difference instantaneously connected)	Control pressure difference of two circuits; under worse conditions, use wet AC change valve, or the change valve with buffering function.
	Slide valve acting fitfully or high local pressures	Grind or replace slide valve.
	Bolt fixing electromagnet loosen	Tighten bolt, and fit a locking washer.
	Long or short push rod of electromagnetic change valve; strong or weak attraction of electromagnet	Repair or replace push rod; overhaul or replace electromagnet.

## Troubleshooting

## 6.2.4 Overflow valve

Table 6-8 Fault Analysis and Troubleshooting for Overflow Valve

Fault Symptom	Cause	Remedy
Vibration and noise	Noise of liquid	Check and rectify it.
	Noise of cavitation, swirling and intercepted liquid after the overflow valve releases liquid	Replace overflow valve.
	Impactive noise of pressure wave when the overflow valve is unloading	Prolong unloading time and gradually open or close change valve which controls unloading.
	Uneven pressure distribution for leading valve and main slide valve	Repair leading valve and main slide valve to enhance their geometric precision; increase diameter of oil return pipe; and use softer spring for main slide valve and oil of proper viscosity.
	Air in oil return line	Check, seal and bleed the line.
	Great counter pressure in oil return line	Increase diameter of oil return pipe and separately set the oil return pipe.
	Air in inner pressure control area of overflow valve	Check, seal and bleed the area.
	Flow exceeds the allowable value	Use overflow valve suitable for the flow.
	Mechanical noise	Check and rectify it.
	Tight or loose fitting of slide valve and valve hole	Repair slide valve and valve hole.
	Too soft or distorted pressure adjusting spring	Replace pressure adjusting spring.
	Loose pressure adjusting nut	Tighten pressure adjusting nut.
	Worn cone valve	Grind and face up cone valve.
Resonance with other elements of system	Diagnose and rectify the vibration and noise of system.	

Fault Symptom	Cause	Remedy
Failure in raising system pressure, or no pressure (reading of pressure gauge almost equals to 0), and useless adjustment	Control oil lacks of pressure due to plug at unloading port of leading overflow valve not fitted	Fit and seal plug.
	Control oil flowing back to oil tank due to oil circuit connecting with remote control port of overflow valve getting opened	Check remote control circuit, and close oil circuit for control oil flowing back to oil return tank.
	No pressure in overflow valve unloading system due to blocked damping hole of leading overflow valve	Clean damping hole and change oil.
	Cone valve, steel ball or pressure adjusting valve not fitted	Fit it.
	Overflow valve stuck at full opening position by dirt	Clean overflow valve.
	No pressure in hydraulic pump	Diagnose and rectify the fault of hydraulic pump.
	Serious oil leak due to damaged elements and line of system	Check, repair or replace them.
Too high system pressure and failed adjustment	Leading valve lacks of control pressure oil due to blocked control oil circuit from main valve to leading valve	Check and unblock control oil circuit.
	Inner oil drain port of leading valve for returning oil blocked by dirt	Clean inner oil drain port of leading valve.
	Slide valve can not be opened due to even oil pressures at both sides of main valve core as a result of heavy wear in damping hole	Insert a stainless steel slice or a slender soft wire into damping hole to plug up a part of this hole.
	Slide valve stuck at closing position due to dirty oil	Clean slide valve and valve hole, and change oil.

Fault Symptom	Cause	Remedy
Failure in raising system pressure and useless adjustment	Oil leak or defective seal at remote control port of leading overflow valve	Check oil leak and oil trickle at remote control port of leading overflow valve, and seal leaking parts.
	Oil leak or defective seal at control valve and line of remote control oil circuit for leading overflow valve	Find out the causes of oil leak or internal leak of remote control oil circuit, and seal leaking parts.
	Oil at oil return port when the pressure had not reached the setpoint value, as a result of serious internal leak at slide valve or internal leak and oil overflowing at overflow valve	Overhaul, ream, repair or replace, and grind slide valve.
	Slide valve stuck due to dirty oil	Clean slide valve and valve hole, and change oil.
	Internal leak due to improper fitting between cone valve/ball valve and valve seat	Face up cone valve and valve seat, replace steel ball or cone valve, or slightly tap cone valve to make it pressed against valve seat.
	Pressure rises slowly or no longer rises due to small flow of leading valve as a result of partially blocked damping hole	Clean damping hole, and change oil.



Fault Symptom	Cause	Remedy
Fluctuant pressure (fluctuant or jumpy reading on pressure gauge)	Failure to maintain a stable working pressure as a result of too soft or distorted pressure adjusting spring for control valve core	Replace it with a new one of proper pressure grade according to the pressure control range.
	Fluctuant pressure due to improper fitting between cone valve/steel ball and valve seat as a result of seizure by dirt or wear	Face up cone valve and valve seat, replace steel ball or cone valve, and clean valve. Alternatively, lay cone valve or steel ball on valve seat; tap it with a wood plate to make it pressed against valve seat.
	Damping hole on main valve sometimes blocked by dirty oil	Check damping hole on main valve, and change oil (if necessary).
	Slide valve acts torpidly due to slide valve scored, distorted, or seized by dirt, or having ellipses, or valve hole bruised or having ellipses.	Overhaul or replace slide valve, and repair valve hole or slide valve to make its ellipses less than 5 μm.
	Change valve remotely connected with overflow valve out of control, or constantly leak (large or small) at remote control port and change valve	Diagnose and rectify the fault of change valve, and seal the remote control port of overflow valve, the change valve and the line.
Leak	Fluctuant pressure and large noise	Check and rectify such phenomena.
	Improper fitting between cone valve/steel ball and valve seat due to wear or seizure by dirt	Clean them, grind cone valve, face up valve seat, or replace steel ball.
	Large fitting clearance between slide valve and valve body	Replace slide valve core.
	External leak	Check seals.
	Loose pipe connector or defective seal	Screw down pipe connector, or replace seal ring.
	Defective or ineffective sealing on relevant joint surfaces	Trim joint surfaces, or replace sealing elements.

6.2.5 Steering cylinder

Table 6-9 Fault Analysis and Troubleshooting for Steering Cylinder

Fault Symptom	Cause	Remedy
Creeping	Air in hydraulic cylinder and line leads to: normal or slightly low reading on pressure gauge, and creeping at two ends of hydraulic cylinder	Set an exhaust device; alternatively, start hydraulic device and make it run at its maximum stroke for several times to compulsorily discharge the air. In addition, seal the system and line to prevent oil leak and air intrusion.
	Negative pressure at certain part of hydraulic cylinder leads to: slightly low reading on pressure gauge, no or few air bubbles in oil tank, and the creeping gradually aggravating	Locate and seal the part with negative pressure to prevent air intrusion; and discharge the air.
	Air suction of hydraulic pump leads to: quite low reading on pressure gauge, powerless hydraulic cylinder, air bubbles in oil tank, and useless exhaust	Bleed the hydraulic pump and oil suction pipe if the fault is caused by air suction of hydraulic pump and oil suction pipe.
	Excessively tightened seal ring leads to: normal or slightly low reading on pressure gauge, and the surface of piston rod whitening with creaks	Adjust seal ring to be neither very loose nor very tight, and ensure that the piston rod can be pulled by hand and without oil leak.
	Non-concentricity of piston rod leads to: slightly high reading on pressure gauge, and the creeping at two ends of hydraulic cylinder gradually aggravating	Fit two piston rods together, and calibrate them on a V-shaped iron plate to keep the non-concentricity within 0.04 mm; or else, replace pistons.
	Bent piston rod leads to: slightly high reading on pressure gauge, regular creeping positions, and partially whitened piston rod	Put a single piston rod, or a piston rod along with a piston, on the V-shaped iron plate; straighten it or them by a press machine or a micrometer.

Fault Symptom	Cause	Remedy
Creeping	Excessively clamped guide rail/sliding block or uneven hydraulic cylinder leads to: slightly high reading on pressure gauge, regular creeping positions, jutter at moving parts, and whitened surface of guiding device	Adjust the tightness of pressing block (bar) of guide rail or sliding block to ensure the precision of acting elements and reduce the sliding resistance. If it doesn't work, check the parallelism between hydraulic cylinder and guide rail, trim and calibrate their contact faces.
	Conflicition between hydraulic cylinder and moving parts due to excessively tightened nuts at both ends of two piston rods	Adjust the tightness of nuts to keep piston rod not tight or loose.
	Poor lubrication leads to: the normal reading on pressure gauge, slight shake or vibration at moving parts (e.g. the work bench), or whitened surface of guide rail	Check and readjust the pressure and flow of lubricant. Otherwise, check whether the oil hole is blocked and the oil viscosity is too high or lubricating performance is ineffective; and timely change oil (if necessary).
	Score at inner wall of hydraulic cylinder or surface of piston, or heavy wear or corrosion at certain parts leads to: fluctuant reading on pressure gauge, and regular creeping	Bore cylinder, and refit a new piston.
	Serious internal leak of hydraulic cylinder leads to: very low reading on pressure gauge, and slow or difficult pressure rising	Replace (aged and damaged) seal ring on piston.

Fault Symptom	Cause	Remedy
External leak	Defective seal ring on piston rod due to damaged surface of piston rod or damaged or aged seal ring	Check piston rod for damage. If any, repair it. Replace damaged or aged seal ring.
	Oil leak due to poor sealing of pipe connector	Check seal ring and contact face for scratch. If any, replace or repair them.
	Defective seal at cylinder cover due to poor processing precision of contact face or aged seal ring	Check the processing precision of contact face and the aging condition of seal ring, and timely replace or repair them.
	Oil leak due to seal ring damaged by local high temperature, which is caused by air insulation compression as a result of poor exhaust	Add exhaust device and timely discharge the air.
	Oil leak at buffering device due to poor processing precision or aged seal ring	Check the processing precision of contact face and the aging condition of seal ring, and timely replace or repair them.
Internal leak	Internal leak and interchange between high/low-pressure chamber due to excessively large fit clearance between worn cylinder hole and piston	If the piston is heavily worn, bore the cylinder, lathe the piston to be thinner with several grooves, and then fit a seal ring to the piston for sealing, or fit a new piston instead.
	Internal leak and interchange between high/low-pressure chamber due to worn or aged seal ring on piston	Replace damaged or aged seal ring in time.
	Internal leak due to inclined or deflectively worn piston as a result of non-concentricity or eccentric load on cylinder body and piston	Check concentricity of cylinder body, piston, and hole of piston rod for cover, and make them align with each other.
	Internal leak due to local drum shape caused by poor processing linearity of diameter of cylinder hole or local abrasion	Bore hydraulic cylinder, and replace piston.

Fault Symptom	Cause	Remedy
Insufficient propulsion, decreasing speed and unstable operation	Serious internal leak due to large fit clearance between piston and hydraulic cylinder (caused by wear), or defective sealing (caused by damaged or aged piston seal rings due to fitting and abrasion)	Replace seal ring in time if the aged seal ring brings on serious internal leak and the hydraulic cylinder moves downward. In case of large clearance, lathe the piston with several grooves, and then fit a seal ring or replace piston.
	Internal leak in high/low-pressure chamber at local sections due to defective seal caused by error in local geometric shape as a result of uneven wear at local sections of hydraulic cylinder	Bore hydraulic cylinder, repair the diameter of cylinder hole, and replace piston.
	Confliction due to increasing friction or resistance caused by excessively pressed seal ring of piston rod at cylinder end or bent piston rod	Adjust the tightness of seal ring for piston rod (to the extent that no oil leak occurs), and straighten piston rod.
	Lower operating speed and unstable operation due to large sliding resistance caused by dirt in oil entering sliding parts	Change oil.
	Lower operating speed of hydraulic cylinder due to high oil temperature, lower oil viscosity and increasing leak	Find out the causes for oil temperature rise, and take radiating and cooling measures.
	Low working pressure or capacity of accumulator, which is used for enhancing the operating speed of hydraulic cylinder	In case of insufficient capacity, replace accumulator; in case of insufficient pressure, apply enough air pressure to the accumulator.
	Insufficient propulsion due to low system pressure cause by lower pressure of overflow valve or leak in pressure control area of overflow valve	Adjust the pressure of overflow valve as per the requirements of propulsion; check pressure of overflow valve; check overflow valve for internal leak, if any, repair or replace overflow valve.

Fault Symptom	Cause	Remedy
Insufficient propulsion, decreasing speed and unstable operation	Unstable operation due to air in hydraulic cylinder	Rectify this fault by the method for faults on air suction and creeping.
	Lower operating speed and unstable operation due to insufficient oil supply of hydraulic pump	Check the hydraulic pump or flow adjusting valve; diagnose and rectify the fault.
Impact	Fast moving speed and hydraulic cylinder without a buffering device	Adjust steering time, slow down movement of hydraulic cylinder; alternatively, add a buffering device.
	Serious leak due to large clearance between plunger and hole in buffering device, and ineffective throttle valve	Replace buffering plunger or set a sleeve in the hole to adjust the clearance to the specified value; check throttle valve.
	Ineffective buttering of one-way valve which buttering at the end as a result of serious leak	Repair and grind one-way valve and valve seat, or replace them.
Abnormal sound and noise	Friction sound of sliding metallic surface due to poor lubrication caused by damaged oil film of sliding surface or high pressure	Stop the machine for checking, avoid the sintering of sliding surface and improve the lubrication.
	Abnormal sound around seal ring due to damaged oil film of sliding surface or serious scratch of seal ring	Improve the lubrication, and in case of serious scratch of seal ring, polish the lip edge with sand paper or sand cloth, or adjust the tightness to eliminate the abnormal sound.
	Shake and huge noise resulted from the insulated and compressed air under the piston when the piston is moving to the end of hydraulic cylinder (especially for vertical hydraulic cylinder).	Move the piston slowly to the top for several times in order to discharge the air in cylinder, which can eliminate this serious noise and prevent burnout of seal ring.

## 6.2.6 Oil filter

Table 6-10 Fault Analysis and Troubleshooting for Oil Filter

Fault Symptom	Cause	Remedy
Deformation of oil filter core (usually on sintering oil filter or screen oil filter)	If the oil filter is not strong and seriously blocked, the oil-passed clearance decreases greatly, and the resistance increases to a great extent, the filter core, under the effect of large pressure difference, will be deformed, and even crushed. (The skeleton of oil filter, sometimes, will be damaged, too.)	Use a stronger skeleton instead, and filter or change oil.
Sintering oil filter shedding granules	The quality of sintering oil filter not in accordance with requirements.	Replace filter core, and check the new filter core, to which the requirements are listed as follows: Under the vibration at an acceleration of 10 g, the filter core shall not shed granules; Under the effect of a pressure at 21 MPa, the filter core shall not shed granules within 1 hour; During the impact load test by a manual pump, the filter core, under the accelerated pressure of 10 MPa, shall not be damaged.
Solders breaking away from metallic grid and skeleton of grid oil filter	Such a phenomenon usually appears on the grid oil filter which is fitted at the inlet of high-pressure pump. The reason of this is as follows: when the melting point of plumbum-stannum electrode is 183°C, and the temperature at the inlet of oil filter has reached 117°C, the strength of electrode will consequently decrease to a great extent and finally the electrode will break away under the impact of high-pressure oil.	Replace the plumbum-stannum electrode by the argentum-cadmium electrode, which has a higher melting point.

6.2.7 Sealing elements

Table 6-11 Fault Analysis and Troubleshooting for Sealing Elements

Fault Symptom	Cause	Remedy
Pulled clearance	High pressure	Lower the pressure; set supporting rings or retainer rings.
	Large clearance	Overhaul or replace sealing elements.
	Improper size of groove, etc.	Overhaul or replace sealing elements.
	Sealing element fit improperly	Refit, overhaul, or replace sealing elements.
Expansion (frothing)	Sealing elements not compatible with hydraulic oil	Replace seal ring or change hydraulic oil.
	Sealing elements dissolved by solvents	Strictly keep sealing elements away from solvents (e.g. kerosene and petroleum).
	Aged hydraulic oil	Change hydraulic oil.
Aging and cracking	High temperature	Check oil temperature; in case of serious friction or overheating (poor lubrication or excessively tight mating), timely overhaul or replace seal elements.
	Naturally aged and deteriorated sealing elements as a result of being stored or used for a long term	Overhaul or replace sealing elements.
	Sealing elements hardened under low temperature	Find out the cause, and improve the lubrication on sealing elements.
Distortion	Sealing elements distorted due to lateral (or longitudinal) load	Use retainer rings to obviate distortion.



Fault Symptom	Cause	Remedy
Wear and damage on surface	Fitting surfaces of sealing elements damaged due to movement and friction	Check the impurities in oil, the process quality of fitting surfaces and the quality of seal rings, and timely overhaul or replace sealing elements.
	Sealing elements damaged due to cutting during installation	Overhaul or replace sealing elements.
	Sealing elements worn due to poor lubrication	Find out the cause, and improve the lubrication on sealing elements.
Damage, adhesion and deformation	High pressure, heavy load, and poor working conditions	Set additional supporting rings or retainer rings.
	Poor quality of sealing elements	Check the quality of sealing elements.
	Poor lubrication	Improve the lubrication.
	Improper installation	Refit, overhaul, or replace sealing elements.
Shrinkage	Sealing elements not compatible with hydraulic oil	Replace seal ring or change hydraulic oil.
	Age hardening or drying shrinkage due to closed storage	Replace sealing elements.

6.2.8 Hydraulic steering gear

Table 6-12 Fault Analysis and Troubleshooting for Hydraulic Steering Gear

Fault Symptom		Cause	Remedy
Oil leakage	Oil leak at joint surfaces between stator of valve body and rear cover	Damaged seal ring	Replace seal ring.
	Oil leak at joint surfaces between valve block and steering gear	Dirt at joint surfaces	Remove the dirt.
	Oil leak at adjusting bolt for safety valve	Fixing bolt not rigid enough	Replace bolt.
	Oil leak at bolt of steering gear	Uneven washer	Grind or replace washer.
Heavy steering	Easy steering when turning the wheel slowly; hard steering when turning the wheel quickly	Insufficient oil supply of pump	Check whether the pump is normal. If not, replace or repair pump.
	Hard steering when turning the wheel slowly or quickly; feeble turning	Defective one-way valve with steel ball inside the steering gear	If steel ball is lost, fit a new $\Phi 8$ one; if the valve is seized by dirt, clean it; if the crown bar is deformed, calibrate or replace it.
	Easy steering under no load or light load, but hard steering under heavier load	Set pressure of overflow valve lower than working pressure, or stuck overflow valve	Adjust set pressure of overflow valve, or clean overflow valve.
	Bubble in oil and abnormal sounds; steering cylinder acting fitfully when the steering wheel is turned	Air in steering system, low oil level, and high oil viscosity	Discharge the air, and check oil suction pipe for air leak, or add oil (i.e. recommended hydraulic oil).

Fault Symptom	Cause	Remedy
Wear and damage on surface	Fitting surfaces of sealing elements damaged due to movement and friction	Check the impurities in oil, the process quality of fitting surfaces and the quality of seal rings, and timely overhaul or replace sealing elements.
	Sealing elements damaged due to cutting during installation	Overhaul or replace sealing elements.
	Sealing elements worn due to poor lubrication	Find out the cause, and improve the lubrication on sealing elements.
Damage, adhesion and deformation	High pressure, heavy load, and poor working conditions	Set additional supporting rings or retainer rings.
	Poor quality of sealing elements	Check the quality of sealing elements.
	Poor lubrication	Improve the lubrication.
	Improper installation	Refit, overhaul, or replace sealing elements.
Shrinkage	Sealing elements not compatible with hydraulic oil	Replace seal ring or change hydraulic oil.
	Age hardening or drying shrinkage due to closed storage	Replace sealing elements.

6.2.8 Hydraulic steering gear

Table 6-12 Fault Analysis and Troubleshooting for Hydraulic Steering Gear

	Fault Symptom	Cause	Remedy
Oil leakage	Oil leak at joint surfaces between stator of valve body and rear cover	Damaged seal ring	Replace seal ring.
	Oil leak at joint surfaces between valve block and steering gear	Dirt at joint surfaces	Remove the dirt.
	Oil leak at adjusting bolt for safety valve	Fixing bolt not rigid enough	Replace bolt.
	Oil leak at bolt of steering gear	Uneven washer	Grind or replace washer.
Heavy steering	Easy steering when turning the wheel slowly; hard steering when turning the wheel quickly	Insufficient oil supply of pump	Check whether the pump is normal. If not, replace or repair pump.
	Hard steering when turning the wheel slowly or quickly; feeble turning	Defective one-way valve with steel ball inside the steering gear	If steel ball is lost, fit a new $\Phi 8$ one; if the valve is seized by dirt, clean it; if the crown bar is deformed, calibrate or replace it.
	Easy steering under no load or light load, but hard steering under heavier load	Set pressure of overflow valve lower than working pressure, or stuck overflow valve	Adjust set pressure of overflow valve, or clean overflow valve.
	Bubble in oil and abnormal sounds; steering cylinder acting fitfully when the steering wheel is turned	Air in steering system, low oil level, and high oil viscosity	Discharge the air, and check oil suction pipe for air leak, or add oil (i.e. recommended hydraulic oil).

Fault Symptom		Cause	Remedy
Failed steering	Steering wheel can not return back to center automatically, and pressure drop increases at the center position	Broken spring	Replace spring.
	Pressure fluctuation obviously increases and steering wheel can not be turned	Pin or opening of universal driving shaft broken or distorted	Replace pin and shaft (do not use other substitutes).
	Steering wheel automatically turns or wobbles leftwards and rightwards	Rotor fitted at incorrect position in relation to universal driving shaft	Replace bolt. Make tooth A on driving shaft due aligned with a gear root of rotor.
	The roller travels defectively; steering cylinder does not act or acts sluggishly when the steering wheel is turned	Defective two-way buffering valve, or spring or steel ball stuck by dirt	Replace spring or clean two-way buffering valve.
Steering wheel can not turn back to center automatically: when the pressure drop increases at the center position or steering wheel stops turning, steering gear does not unload (i.e. the roller travels defectively.).	Broken spring	Rectify the fault according to the corresponding causes.	
	Valve core axially stuck by steering shaft		
	Large coaxiality error between axes of steer shaft and valve		
Failure in switching to manual steering: during power steering, the driver can not feel he has turned the steering wheel to the limit when the piston of steering cylinder is already at the limit; during manual steering, the steering cylinder doesn't switch when the steering wheel is turned	Large rotation resistance of steering shaft	Replace rotor and stator.	
	Large axial or radial clearance between rotor and stator		

### 6.3 Electrical Parts

#### 6.3.1 Basic electrical system

Table 6-13 Fault Analysis and Troubleshooting for Basic Electrical System

Fault Symptom	Cause	Remedy
No power supply of complete machine	Fuse burnt	Replace fuse.
	Damaged ignition key switch	When the machine is blocked, dismantle it for coating lubricant; replace ignition key switch when the contact is damaged.
	Damaged DC contactor	Replace DC contactor
Insufficient power in storage battery	Failure of charging lines	Check whether the indicator light HL1 and resistance R3 are normal and in good connection; replace it if necessary.
	Damaged storage battery	Charge it when the indicator of storage battery turns black; replace it if it turns white.
	Fault of engine	If the voltage on terminal B+ is less than 26 V after starting the engine, the generator is damaged. Send it for maintenance by professional personnel.
Failure of engine startup	Fuse FU8,F12,F53 and F11 burnt	Confirm if wirings of ignition switch, starter motor and parking solenoid valve are normal after replacing it with the fuse of the same type.
	Damaged starter relay K14	Replace starter relay K14 if the circuit is normal.
	Damaged relay K23	Replace starter relay K23 if the circuit is normal.
	Defective starter motor	Confirm if there is short circuit on lines firstly; if not, start it after replacing it with the fuse of the same type. It is usually caused by the seizure of clutch mechanism and bad performance of control contact; the professional repair is needed.

Fault Symptom	Cause	Remedy
No display of engine speed signal	Poor contact of lines	Check the lines, in particular terminal W of generator.
	Defective engine	In case of damaged engine or no output from terminal W, ask for professional repair.
	Abnormal power at SYMC input terminal	Check for short circuit till voltage of SYMC is normal.
Abnormal fuel gauge indication	Pointer always at "max." mark	Short circuit. Check and repair
	Pointer always at "min." mark	Broken circuit. Check and repair. Damaged sensor. Replace it.
	No response of pointer after turning on/off the power.	Damaged fuel gauge. Replace it.

6.3.2 Electrical system of working devices

Table 6-14 Fault Analysis and Troubleshooting for Electrical System of Working Devices

Fault Symptom	Cause	Remedy
No traveling or sluggish traveling	Brake switch and emergency stop switch not reset	Reset brake switch and emergency stop switch.
	Defective pressure relay	If the machine still travels with the pressure relay plugged off, the relay is damaged. Replace the relay.
	Defective wiring	Check for short circuit or poor contact of solenoid socket. Rectify it.
	Damaged brake/brake release solenoid; stuck valve core	Replace solenoid or clean valve core.
No vibration	Emergency stop switch not reset	Reset emergency stop switch.
	No vibration at manual gear	Damaged vibration selection switch or toggle switch. Replace it.
	No vibration at auto gear	Check for poor contact in circuit. Rectify it. When traveling speed is over 1.5 km/h, the vibration button must be pressed down. Stop vibration forcibly.
No speed signal	Defective wiring	Check the wiring, esp. the sensor harness for damage or poor contact of connectors.
	Large clearance between sensor and motor flywheel gear	Re-adjust the clearance to 0.4~0.6 mm.
	Damaged sensor	Replace sensor.



## 6.3.3 Fuses

Table 6-15 Fuses

Code	Part	Current	Code	Part	Current
FU11	Starter motor	30A	FU35	Tail light	10A
FU12	Ignition switch	15A	FU41	Reserved	10A
FU50	Reserved	15A	FU21	SYMC load power	20A
FU54	Excitation	10A	FU22	SYCD working power	5A
FU13	Maintenace socket	15A	FU23	SYMC control power	5A
FU31	Horn & backup alarm	10A	FU14	SYCD power	5A
FU32	Parking/steering/light	10A	FU24	Power control	5A
FU33	Reserved	10A	FU25	Sensor power	5A
FU34	Front floodlight	15A	FU36	Reserved	10A
FU37	Reserved	15A	FU38	Reserved	10A
FU39	Reserved	10A	FU40	Rear frame light	10A
FU51	Water pump	20A	FU52	Reserved	20A
FU53	Reserved	25A			

6.3.4 Radio

Table 6-16 describes the fuses of the roller.

Table 6-16 Radio

Symptom	Possible Cause	Suggested Action
Any abnormality	Wrong setting or halted CPU.	Method 1: press SEL and DISP keys, and hold them for 3 seconds to reset the radio. Method 2: disconnect the power supply of the radio at the harness connector, and then connect it to reset the radio.
Radio can't be started.	<ul style="list-style-type: none"> <li>The power supply ACC of ignition switch has no circuit, meanwhile date appears on the display.</li> <li>The power supply B+ (yellow) of the battery has no circuit, meanwhile no date appears on the display.</li> </ul>	<ol style="list-style-type: none"> <li>Check the red wire for power supply at the rear harness connector of the radio.</li> <li>Check the yellow wire for power supply at the rear harness connector of the radio.</li> </ol>
Abnormal display	Halted CPU	Press SEL and DISP keys, and hold them for 3 seconds to reset the radio.
U disc can't be read or be played after a certain time.	Inferior U disc may be read on a computer because the drive current through the U disc connector of the computer is enough. However, inferior U disc could make the U disc connector of the radio heat severely.	Replace it with qualified U disc.
SD card can't be read or be played after a certain time.	Inferior SD card	Replace it with qualified SD card.
The radio can receive no or few stations. Frequencies change as manual or auto search functions.	<ol style="list-style-type: none"> <li>The signal of antenna has short or open circuit.</li> <li>Stations are in repair and their signals are weak.</li> </ol>	<ol style="list-style-type: none"> <li>Check the antenna connector of the radio; check if there is short circuit between the antenna at top of cabin and the iron roofing.</li> <li>Try it in another time or place.</li> </ol>
Normal display but no sound	<ol style="list-style-type: none"> <li>The horn is broken or the harness is inferior.</li> <li>The radio can receive no or few stations with MP3 playing normally.</li> </ol>	<ol style="list-style-type: none"> <li>Check the horn and the harness.</li> <li>Refer to the above one.</li> </ol>

## 6.4 Air Conditioning System

The common faults of air conditioning system generally are electrical faults, mechanical faults and refrigerant and freezing lubricant failures. The symptoms are no cooling or insufficient cooling or abnormal noise.

### 6.4.1 System with poor cooling

Failure symptom: Start the engine and keep medium speed for about 3 mins. Turn on the blower and air conditioner switches, but there is no cold air blown out. For fault checking and handling, see Table 6-17.

Table 6-17 Fault Analysis and Troubleshooting of Poor Cooling

Fault Symptom	Cause		Remedy		
No rotating of evaporator fan	Fuse burnt		Change		
	Bad switch connection		Repair or change		
	Bad rheostat		Repair or change		
	Bad motor		Repair or change		
	Open circuit in conductor		Repair or change		
	Electromagnetic clutch not engaged	Bad idle speed control		Repair or change	
		Bad temperature control		Repair or change	
		Bad pressure switch		Repair or change	
		Bad solenoid		Repair or change	
		Open circuit in conductor		Repair or change	
	Electromagnetic clutch engaged	Compressor not rotated	Loose or damaged belt	Adjust or change	
			Compressor fault	Remove and check	
		Compressor rotated	Refrigerant leaked or filled too much		Make up or discharge
			Expansion valve plugged		Change
Dry filter plugged			Change		
Pipe plugged			Change		
Compressor fault			Remove and check		

6.4.2 Insufficient system cooling

Causes: Insufficient cooling can be caused by many reasons. All factors that reduce the refrigerant flow at the expansion valve outlet may decrease the system cooling capacity; all factors that can cause excessive temperature and low pressure at high or low sides in the system can also lead to insufficient system cooling. For the specific cause and inspection of the faults, and troubleshooting methods, see Table 6-18.

Table 6-18 Analysis and Troubleshooting of Insufficient System Cooling

Fault Symptom		Cause		Remedy	
Insufficient air flow	Blower could rotate	Normal operation	Air filter blocked	Clean filter	
			Frosted evaporator	Break of thermistor	Repair
				Low battery voltage	Check battery
				Thermistor fault	Change
			Displacement of air duct	Check and repair	
	Slow rotation	Loose or corroded battery terminals		Check and repair	
		Blower motor fault		Check and repair or change	
	Blower does not rotate	Rotating at high speed but no rotating at low and medium speeds	Rheostat fault		Change
		No rotating at high, medium and low speeds	Adjustable resistance fault and fuse blown		Check, repair or change
			Blower motor fault		Repair or change
Blower switch fault			Repair or change		
Blower relay fault			Check or change		
Improper wiring or connection falling		Check or change			

Fault Symptom		Cause		Remedy		
Normal wind	Compressor operates normally	Normal pressure	Outside air infiltration		Check vents	
			Temperature control system fault		Check and change related parts	
		Abnormal pressure	Pressures on both high and low sides are too high	Excessive refrigerant		Discharge proper refrigerant from low-pressure valve.
				Air in the cooling cycle		Discharge refrigerant, vacuumize and then fill refrigerant.
				Bad condenser		Check and repair it.
			High pressure is too high and low pressure is too low	Condenser pipe blocked		Find out reason and repair or change
				Expansion valve opening is too large		Adjust or replace
			High pressure is normal; low pressure is too high	Evaporator inlet temperature too high		Check vents and access opening, etc.
				Improper installation of temperature sensing bulb for expansion valve		Check and repair
				Compressor fault		Check and repair or change
	High pressure is slightly low; low pressure is too high	Insufficient refrigerant		Find out leaks, repair and then refill		
		Air filter blocked		Clean		
		Expansion valve screen blocked		Clean or repair.		
		Refrigerant leaked		Find out leaks and repair		
	Both high and low pressures are too low	Temperature sensing bulb for expansion valve faulted		Check, repair or change		
	Compressor operates abnormally	Compressor fault			Check, repair or change	
		Electromagnetic clutch fault			Check, repair or change	
Driving belt damaged or slipping			Check, repair or change			
Pressure switch fault			Check, repair or change			

**6.4.3 Abnormal noise caused by cooling system**

Causes: Normally, it belongs to mechanical faults, such as looseness fasteners, over-worn moving parts, poor lubrication for relative moving parts. See Table 6-19.

Table 6-19 Analysis and Troubleshooting of Abnormal Noise Caused by Cooling System

Fault Symptom	Cause	Remedy
Conveyor belt part	Too loose conveyor belt	Adjust belt tightness
	Over-worn conveyor belt	Change
	Loose bracket	Repair
	Tension wheel bearing	Change
Blower part	Abnormal sound in blower fan	Check the fan for debris, or repair and change
	Motor worn too much	Repair or change
Electromagnetic clutch part	Electromagnetic clutch slipping	Repair
	Improper coil installation	Repair
	Skew pulley	Adjust
	Excessive refrigerant	Discharge
	Insufficient freezing lubricant	Refuel
	Compressor fault	Remove and check.

### 6.4.4 Air heating device fault

There are usually faults such as no heating or the heating cannot be shut off, for air conditioning system with heating function. See Table 6-20.

Table 6-20 Analysis and Troubleshooting of Heating Fault

Fault Symptom	Cause	Remedy	
No heating	No air flow	Burnt fuse or damaged circuit	Check and replace the fuse. Use a multimeter to check the circuit.
		Damaged fan	Use a multimeter to check the fan; repair or replace the fan.
	Normal air flow	Solenoid cannot be switched on due to de-energizing	Use a multimeter to check the circuit.
		Solenoid cannot be switched on due to damage	Turn on the heating switch. You can feel the solenoid action. Repair or replace solenoid.
Heating cannot be shut off	Normal air flow with heating	Solenoid is internally stuck, which cannot be closed	Check, repair or replace solenoid.

### 6.4.5 Other faults

In addition to the above faults, the other faults for air conditioning system of the roller are: good and bad cooling effect at times, evaporator frosting, etc. See Table 6-21.

Table 6-21 Analysis and Troubleshooting of Other Faults

Fault Symptom	Cause	Remedy
Better system cooling at first, but inadequate cooling after using a period of time; there are bubbles in observation hole of the storage bottle; "reading" of high and low pressure gauges are slightly low	Joints loose due to vibration, leading to improper use in case of leakage	Find out the leak with a leak detector; carefully tighten the loose parts and make up R134a.

Fault Symptom	Cause	Remedy
System does not refrigerate; hot air flows out of the vent; there is no temperature difference at inlet and outlet of expansion valve; "reading" from low pressure gauge is low	Temperature sensing bulb of expansion valve leaks due to damage, resulting in the valve hold closed	Replace expansion valve and recharge R134a.
Air from vent is not cold, and the compressor temperature rises. The pointer of low pressure gauge decreases rapidly, close to 0; and "reading" from high pressure gauge is slightly high	There are impurities in the system; expansion valve screen is clogged; thin frost or "sweating" occurs in the expansion valve	Start the air conditioning system intermittently, which can eliminate the transient clogging if it is not serious. Remove the expansion valve and clean with alcohol. Recharge R134a after emptying the system.
Insufficient cooling capacity; evaporator frosted; "readings" of high and low pressure gauges are slightly low	Throttle orifice in expansion valve does not work	Drain off the system, replace the expansion valve and re-fill R134a.
After running for some time, system cooling capacity decreases; "reading" of high pressure gauge is slightly high, and "reading" of low pressure gauge is less than 0.2 MPa	The desiccant in storage bottle saturated; throttle orifice blocked by ice	Empty the system, replace the liquid storage bottle and recharge R134a.
After starting the cooling system, there is only air instead of cold air; readings of high and low pressure gauges are stationary	Bad contact of temperature control switch or the compressor's electromagnetic clutch coil damaged	Check if the temperature control switch is damaged with a multimeter; replace the compressor's electromagnetic clutch.
Compressor electromagnetic clutch operates frequently, with short engaging time; cold air in vehicle, and normal readings of high and low pressure gauges	Opening of temperature control switch is too small, which automatically forces the compressor to stop, resulting in insufficient cooling capacity	Check temperature control switch to make it turn to the position close to the electromagnetic clutch as much as possible.



## 6.5 Troubleshooting Examples

Example 1: Vibration fault

Fault symptom:

No vibration at low vibration frequency.

Fault cause:

- Fault in low-frequency vibration control circuit.
- Defective low-frequency vibration solenoid.
- Pump failing to change angle due to defective 3-piston switch of vibration pump.

Remedy:

Set to the vibration frequency and the drum vibrates. It means the mechanical part, vibration pump, and vibratory motor are normal. Check the low-frequency vibration control circuit and the electrical connections are good. Replace the low-frequency vibration solenoid, and the drum vibrates at low frequency. It indicates the solenoid is in trouble. Test the valve, and the valve core does not act no matter the valve is energized or not. There is mechanical fault. In this case, replace the valve.

Example 2: Water spraying fault

Fault symptom:

The roller is unable to spray water.

Fault cause:

The possible fault causes are as follows:

- Fault of water pump selection switch S16 and its circuit.
- Fault of water spraying interval selection switch S17 and its circuit.
- Fault of DC voltage regulator.
- Fault of water spraying relays K25,K26.
- Water of water pump.

**Remedy:**

Check circuits. Due to blocked pipes, the load current of the water pump increases. The DC voltage regulator will function overload protection. Under this circumstance, dredge the pipes.

**Example 3: No traveling****Fault symptom:**

No traveling or sluggish traveling

**Fault cause:**

- Brake switch and emergency stop switch not reset
- Defective neutral position switch
- Defective brake release valve circuit
- Damaged brake release solenoid or stuck valve core

**Remedy:**

Reset brake switch and emergency stop switch. Check the neutral position switch, and the circuit is normal. Check the voltage of brake release valve, and the valve is properly grounded. Replace the solenoid, and the machine travels normally. Clean the valve core, and the machine works normally. Thus, the fault is caused by the dirty solenoid core. Regularly check and maintain the valve core.

Lined area for troubleshooting notes, consisting of multiple horizontal dashed lines.

BLANK PAGE

BLANK PAGE

# SANY

## Specifications

### 7 Specifications

7.1 Dimension of the Equipment .....	7-1
7.2 Specifications of the Equipment .....	7-2



## 7 SPECIFICATIONS

### 7.1 Dimension of the Equipment

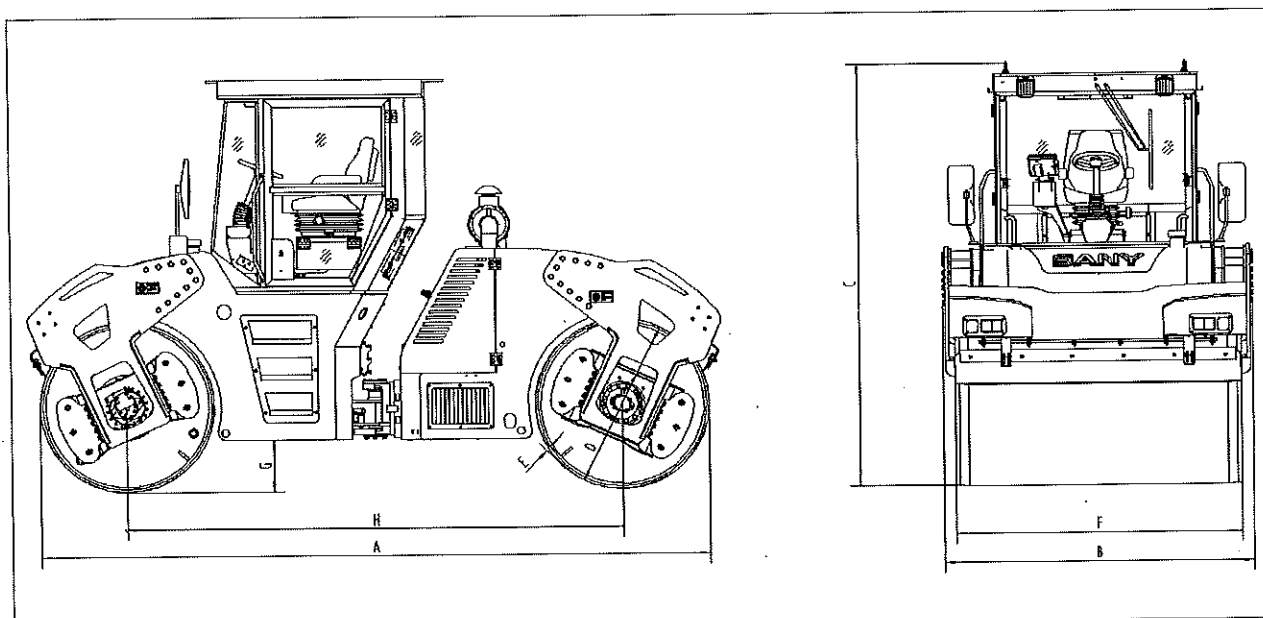

Fig.7-1

Table 7-1 Dimension of the equipment

	Item	Unit	STR100 Series Standard Machine	STR130 Series Standard Machine	STR140 Series Standard Machine
A	Length	mm	5165	5165	5165
B	Width	mm	2100	2305	2305
C	Height	mm	3215	3215	3315
D	Diameter of vibratory drum	mm	1240	1300	1400
E	Thickness of vibratory drum rim	mm	17	20	20
F	Vibratory drum width	mm	1900	2135	2135
G	Min. ground clearance	mm	360	380	490
H	Wheel base	mm	3689	3689	3689

Note: The above data are specifications of standard machine, so specific data of actual machine may be different.

Materials and specifications are subject to change without notice in accordance with our continuous technical innovations.

## 7.2 Specifications of the Equipment

Table 7-2 Technical Specifications

	Technical Parameters	STR100 Series Standard Machine	STR130 Series Standard Machine	STR140 Series Standard Machine
Mass and load	Operating mass (kg)	10500	13000	14000
	Front drum module mass (kg)	5250	6500	7000
	Rear drum module mass (kg)	5250	6500	7000
	Static linear load at front drum (N/cm)	271	298	330
	Static linear load at rear drum (N/cm)	271	298	330
Compaction mechanism	Vibration frequency (Hz)	50/61	50/61	50/61
	Nominal amplitude (mm)	0.75/0.3	0.67/0.31	0.62/0.28
	Exciting force (kN)	140/94	169/119	169/119
Power-driving performance	Travel speed (km/h)	0 – 12	0 – 12	0 – 12
	Work speed (km/h)	0 – 6.5	0 – 6.5	0 – 6.5
	Theoretical gradeability (%) (Vibration)	30	30	30
	Theoretical gradeability (%) (No vibration)	35	35	35
	Steering angle (°)	±33	±33	±33
	Swing angle (°)	±8	±8	±8
	Min. turning diameter (mm)	13530	14000	15800
Engine	Manufacturer	Cummins	Cummins	Cummins
	Model	QSB4.5-C160-30	QSB4.5-C160-30	QSB4.5-C160-30
	Rated engine speed (r/min)	2200	2200	2200
	Rated power (kW)	119	119	119
Capacity	Battery (VxAh)	24×120	24×120	24×120
	Water tank(L)	800	800	800
	Fuel tank (L)	230	230	230
	Hydraulic oil tank (L)	100	100	100

Note: The above data are specifications of standard machine, so specific data of actual machine may be different.

Materials and specifications are subject to change without notice in accordance with our continuous technical innovations.



Blank page with horizontal dashed lines for specifications.

BLANK PAGE



1

2

3

4

[www.sanyglobal.com](http://www.sanyglobal.com)



## **SANY AUTOMOBILE MANUFACTURING CO., LTD**

Address: SANY Industry Town, Economic and Technological Development Zone,  
Changsha, Hunan, China 410100

Service Hotline: 0086 4006098318

E-mail: [crd@sany.com.cn](mailto:crd@sany.com.cn)

