

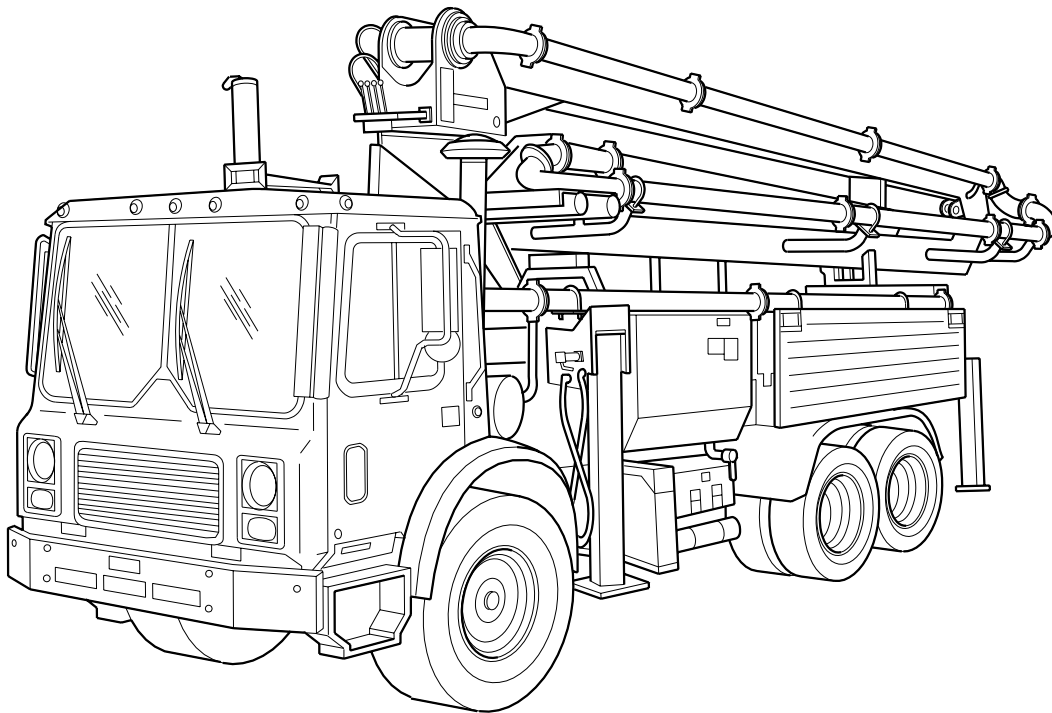

SCHWING
AMERICA INC.

***GUIDE FOR TROUBLESHOOTING
CONCRETE PUMPS***



BPL 801 - KVM 28

DOCUMENT #699000

5900 Centerville Road
St. Paul, MN 55127
Tel 651-429-0999
Fax 651-429-3464
www.schwing.com

REV. 5/15/02

THIS MANUAL IS INTENDED TO ASSIST AUTHORIZED PERSONNEL WITH REPAIR OF CONCRETE PUMP EQUIPMENT. SCHWING AMERICA, INC. IS NOT RESPONSIBLE FOR DAMAGE OR ACCIDENTS CAUSED BY MISUSE, IMPROPER MAINTENANCE, OR NEGLIGENCE OF THIS EQUIPMENT. THE EXISTENCE OF THIS GUIDE AND ITS CONTENTS DOES NOT NEGATE THE NEED TO USE COMMON SENSE WHEN WORKING WITH HYDRAULICALLY POWERED AND ELECTRICALLY CONTROLLED EQUIPMENT.

GUIDE FOR TROUBLESHOOTING CONCRETE PUMPS
BPL 801 - KVM 28

Introduction.....	3
SCHWING America Service Department:	3
A. Pressure Gauge.....	4
Basic Rule	4
B. Oil TEMPERATURE	4
C. Number of Strokes	5
Basic Rules	5
D. Compensating Oil.....	7
E. Adjustment of Throttle Valves.....	8
F. Freeing Seized Gate Valves.....	9
G. Checking Safety Valves	10
H. Selection and Changeover Operations.....	11
I. Hydraulic Schematic and Sequence Diagrams	12
Legend - Sequence Diagrams 1 thru 8 - BPL 801	12
First Working Stroke.....	14
End of First Working Stroke	15
Control Stroke.....	16
End of Control Stroke	17
Second Working Stroke.....	18
End of Second Working Stroke & Control Stroke	19
End of Control Stroke & Beginning of Third Working Stroke.....	20
Third Working Stroke.....	21
1 Concrete pump does not work, although it is switched on.	22
2 Concrete pump runs very slowly (few strokes) at very low pressure.	24
3 Concrete pump runs but with unexpectedly high hydraulic pressure. The oil is also heating more quickly than is normal.	25
4 Concrete pump runs with normal number of strokes. The output is only half as it would correspond to the number of strokes. The gauge alternatively shows one stroke with normal pressure and another stroke with a very high pressure. The water level in the water box is rising and falling in the same sequence.	25
5 The concrete pump runs with normal number of strokes. The output is less than would correspond to the number of strokes.	26

6	After every 2nd stroke, the concrete pump stops for a short while. At this time, the gauge indicates safety pressure. On the other stroke, there is no interruption or delay.	27
7	The concrete pump stops. The gauge indicates safety pressure. One differential cylinder is in the rear end position, i.e., the piston fixture is close to the rear wall of the water box.	28
8	The concrete pump runs with an excessive number of strokes. It looks as if it is running faster. In fact, it is running at constant speed, but with a shorter stroke. Check the movement of the piston rods in the water box.	30
9	After each stroke, the pressure increases in jerks up to maximum safety pressure. The start of the next stroke is retarded for a fraction of a second. Also the hydraulic oil is heated more rapidly than normal.	31
Defects With the Concrete Pump		32
10	Flushing containers overflow, consequently much higher consumption of flushing agent.	32
11	The hydraulic oil tends to overheat - in excess of 80° C.	32
Defects With the Placing Boom, Remote Control, and Hydraulic Outriggers.....		32
Defects With the Remote Control.....		32
Defects With the Remote Control (cont'd)		33
Defects With the Placing Boom		33
Defects With the Placing Boom (cont'd).....		34
HYDRAULIC SCHEMATIC - KVM 28 BOOM		35
BPL 801 ELECTRICAL SCHEMATIC		36
BPL 801 ELECTRICAL SCHEMATIC		37
R1	The agitator stops frequently and can only be set in motion again after reversing briefly.	38
R2	The agitator runs with unexpectedly high pressure.	39
Hydraulic circuit diagram, agitator, compressor, water pump, forward reverse		39
W1	The water pump does not work, although the tank is filled and the input is unobstructed.	40
W2	Insufficient water is pumped by the pump and the pressure is low.	41

BPL 801/KVM 28 T.S.G.

Introduction

We try to manufacture our machines to be as reliable as is possible in service. With the new concrete pumps of the BPL series, modifications to the hydraulic control system and operation of the gate valves, the reliability has been improved still further in service. If, however, problems are experienced, these can usually be very quickly recognized and dealt with. This booklet has been compiled to allow you to check quite quickly and

easily the probable cause of the failure or failures. We recommend that you read this booklet before the machine is put into service and that you thoroughly acquaint yourself with its contents enabling you not only to understand the machine's function, but even better, to allow you to anticipate a failure by a typical or intermittent malfunction, preventing expensive and the possibility of embarrassing breakdowns on site. In the following pages, we will endeavor to explain initial function checks, maintenance hints and tips and testing procedures which ought to be known by concrete pump operators as well as maintenance people. We have also reproduced the stage by stage operation of the hydraulic circuit with multicolor diagrams which you will find in the section after "switching operations".

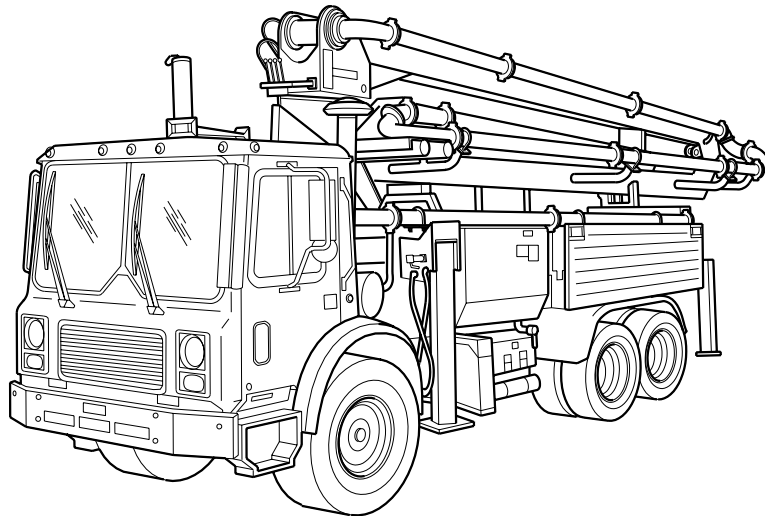

If you have attempted to correct faults or troubleshoot a malfunction in the machine and you have been unable to solve the problem, we recommend that you contact our After Sales Service Department.

SCHWING America Service Department:

- TEL: 1-888-292-0262
- TEL: (651) 653 2299
- FAX: (651) 429 2112

BEFORE YOU CALL please make note of the following information so that our Service Technicians will be better able to help you:

1. Machine model and serial number (stamped on the machine serial plate on the left side of the subframe, behind the truck cab).

2. The hydraulic working pressure at the time the failure occurred.
3. Strokes per Minute of the concrete pump and engine rpm at the hydraulic working pressure time.
4. Pressure at which the main safety valve opens.
5. Length and diameter of the delivery pipeline including position, number and type of any bends used.
6. Quality and slump of concrete and if known, the mix design.

With the above information our experienced Service Technicians should be able to advise you by telephone what the trouble may be and the best way to correct the problem.

A. Pressure Gauge

The most important instrument for not only checking the concrete pump during operation but also for indication of possible defects, is the main pressure gauge. The safety pressure is the pressure at which the safety valve opens. The working pressure is the pressure in each situation that the concrete pump is operating. We would explain the pressure differs from job to job and it is not necessary to adjust the working pressure. On the contrary, the working pressure automatically increases enabling resistance of the concrete in the pipeline to be overcome. This resistance and, therefore, the working pressure is a direct result of the stiffness and coarseness of the concrete plus the length of the pipeline being used and finally the speed at which the concrete is being pumped. It is possible in extreme cases that the working pressure may increase up to 250 bar depending of course on the pump model. Working pressures obviously cannot be higher than the pre-set safety pressure on the safety valves as these will open and relieve pressure. All safety pressures for the differing concrete pump models are shown in the relevant machines' operating instructions books.

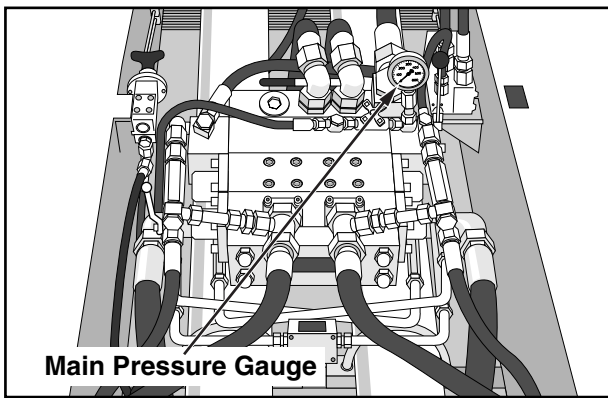

Main Pressure Gauge

Basic Rule

The working pressure should never be in excess of 90% of the pre-set safety pressure (not applicable for system III).

Where the working pressure exceeds 90%, either the pumping speed should be reduced or an alternative and larger diameter pipeline should be used or finally the "pumpability" of the concrete should be improved prior to pumping. On each occasion, the safety pressure must be checked.

As a pump operator, you should automatically check the working pressure several times during operation. After some weeks experience, you will no doubt be able to assess before starting any pumping operations how high the pumping or working pressure will be. Pressure checks are most important. You should always carry a spare gauge so you are able to quickly replace this very important instrument on the job.

B. Oil Temperature

It is also very important to check operating oil temperatures during pumping especially on extended pours. Temperatures between 40° and 60° C after approximately two hours pumping are quite normal. Temperatures of 80° C will not harm either the oil or the concrete pump, but there is an indication of an irregularity within the hydraulic system because normal oil temperatures should not be as high as this. Try and establish the cause of this heat increase. NOTE: If the pump is operating within an enclosed building or confined space, it is most important to provide adequate ventilation.

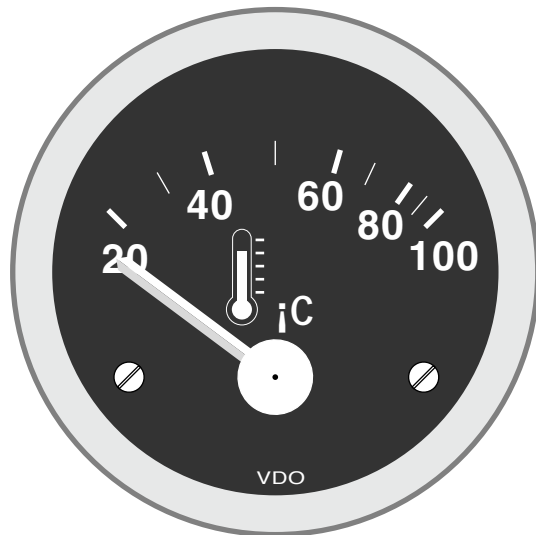

OIL TEMPERATURE

C. Number of Strokes

The technical term "strokes" simply means the piston travel from one end of the cylinder to the other. Therefore, when 21 strokes occur within one minute, this will be the operating speed. The maximum design number of strokes per minute is 28. We recommend that you check the operating speed by a watch equipped with a second hand. If pumping is required at any speed less than the maximum, the engine should be slowed down, but not less than 1500 rpm. At this speed damage could possibly be caused. Secondly, if you have to pump even more slowly than this, we suggest you engage a lower gear so that the engine will be working above 1500 rpm giving the desired number of strokes per minute. The maximum number of strokes possible to obtain are indicated on the build plate of your individual machine, and they are also repeated in the operating instruction book under "technical data". The maximum number of strokes mentioned should be obtainable when the vehicle gear box is engaged in top or direct drive (generally 5th or 6th gear) and when the vehicle engine is running at maximum governed revolutions provided that the pumping operation and the working pressure are lower than 90 bar (for BPL 800 with 130 hp engine and other models see technical data). At higher pressures, the main hydraulic pump automatically reduces its output. This has been purposely designed preventing overload of prime movers. However, do not misunderstand that the working pressure can be much higher. In this case, it will be impossible to reach the maximum number of strokes simply because the hydraulic pump can now only deliver a reduced volume of oil in spite of the same input rpm. This is quite clearly explained on the output diagram where you will see the number of strokes and the corresponding output in relation to the working pressures. If the output diagram is not available in the instruction book, please request same either from the manufacturer or your distributor. It should also be your discipline to check as often as possible the number of strokes during your working day. Then you will see for yourself the direct relationship between the working pressure required and the number of strokes possible. The high working pressure also has an effect on the hydraulic pump automatically reducing its output and the number of strokes possible. Conversely, a lower number of strokes intentionally produced by you will also reduce the working pressure. With a low number of strokes per

minute the concrete will flow more slowly through the pipeline. For less concrete velocity the pistons absorb less power which means less pressure. Please pay due attention to these interconnected points. Then you will get a better appreciation about the lay-in parts and life of the concrete pump.

Basic Rules

1. At working pressures below 90 bar (BPL 800/130 hp) the number of strokes directly influences the working pressure. The lower or higher the number of strokes, the lower or higher the pressure will be as previously explained. Lower speeds of concrete flow will require lower operating pressures.
2. At working pressures above 90 bar (BPL 800) the working pressure directly influences the number of strokes. The higher the pressure, the lower the number of strokes because the hydraulic pump will automatically reduce its output.

In general, try to avoid pumping with the maximum number of strokes, only doing so when it is absolutely necessary. There is no advantage whatsoever if you are able to empty a ready mix truck of 5 m³ capacity within 5 minutes, then leaving you to wait a further 10

minutes for the arrival of the next ready mix truck. It is much better to pump slowly from the outset thus preserving the machine and your nerves and not forgetting the considerable decrease in working costs - your chief will be grateful.

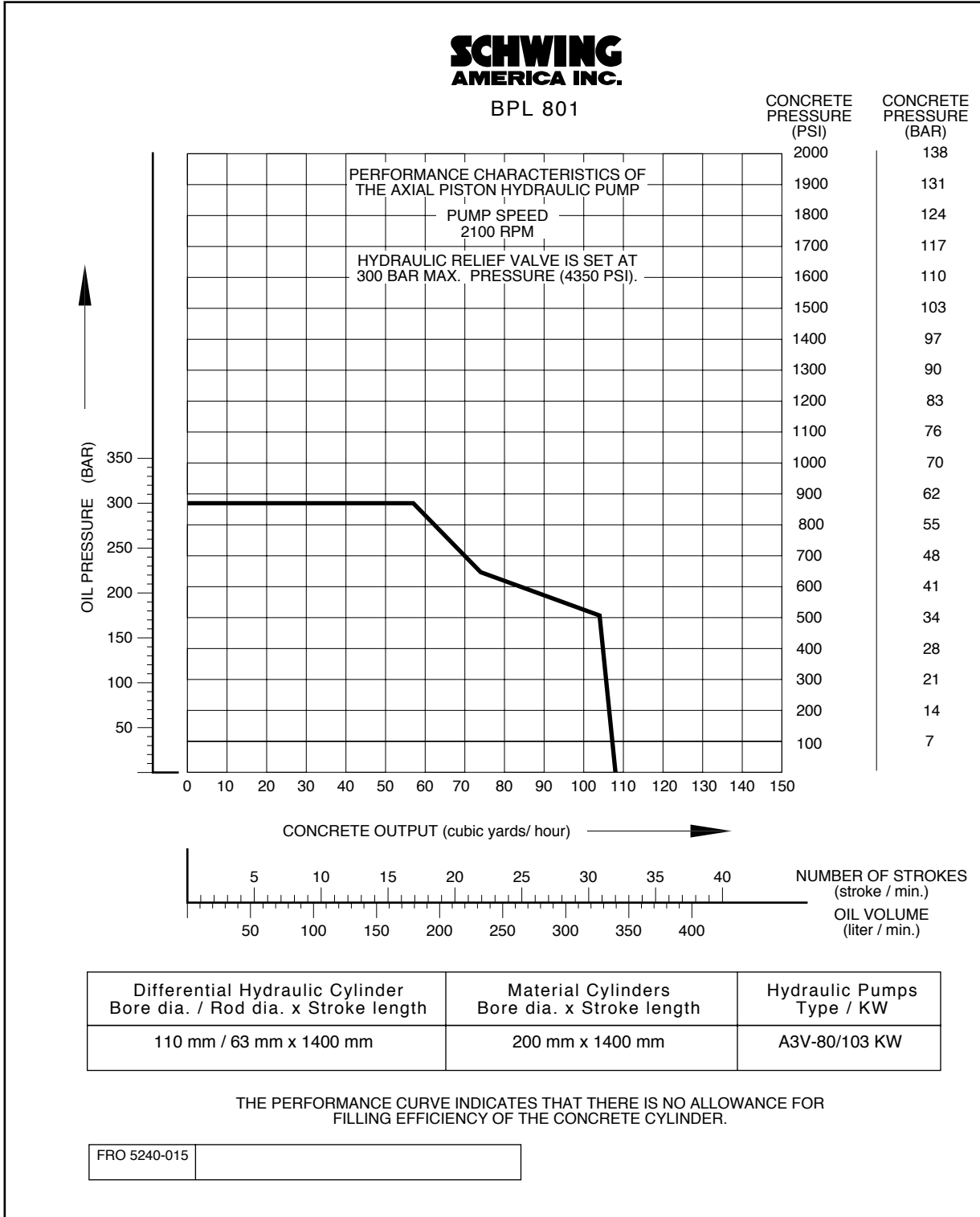

D. Compensating Oil

The differential cylinders of BPL pumps are actuated at the rod end. In order to push cylinder (a) forward, pressure oil must be conveyed to the rod end (in front of piston cylinder [b]). The piston of cylinder (b) then travels backward to the cylinder extremity. The ends of the two cylinders are interconnected with a hydraulic

line allowing the oil to be displaced by piston (b) as it travels backwards through the line into cylinder (a) which forces its piston forward. On the alternate cycle, the oil between the two pistons will then be pushed back from (a) to (b), the same quantity of oil prevailing which is termed compensating oil, obviously transmitting power and movement from one differential to the other.

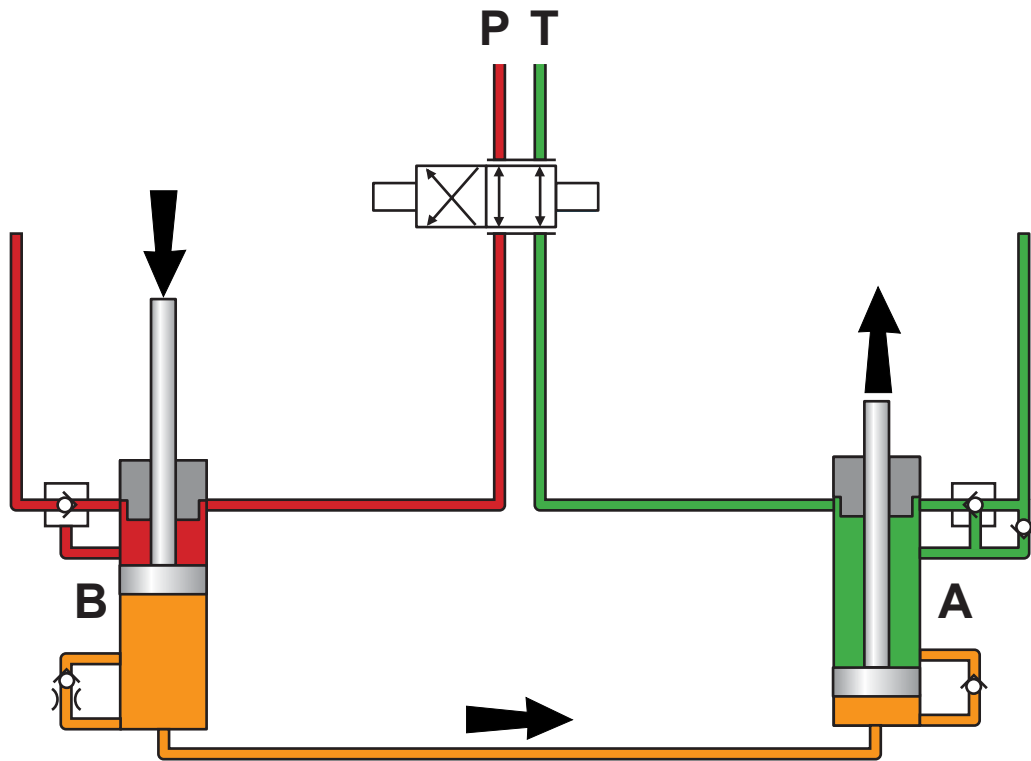

E. Adjustment of Throttle Valves

- a. With cold oil - up to 30° C temperature. With the engine set to run on half speed and the concrete pump selected to neutral, shut both throttle valves completely and open them approximately 1 π turns, and then select concrete pump to pumping. There will most probably be insufficient opening of the throttle valves at this setting and there will be a delay caused at the end of each stroke because the impulse oil flow is restricted and will consequently take more time to complete a cycle. It will also be noted that the pressure on the gauge will rise up to the maximum safety pressure each time the changeover takes place. Then open both throttle valves another π of a turn simultaneously, and progressively open the throttle valves until such times as the changeover time becomes almost 0 between one gate valve and another. While this is happening the gauge will still indicate an increase in pressure at the conclusion of each stroke. However, when the oil obtains its correct working temperature, the gate valve changeover

will become smoother and peak pressures should not be recorded when the changeover takes place. Having gone through this procedure, any necessary corrections or fine tuning of the settings could take place during pumping operations at any convenient time. Do not forget to finally tighten the lock screw once you have completed adjustment.

- b. With warm oil - 30° C and above. Again halve the number of rated engine revolutions and proceed progressively as with cold oil with opening the throttle valves at approximately 1 turn. Continue adjusting the throttle valves until the peak pressures during changeover have virtually disappeared. However, you will notice that the gate valves will still traverse quite strongly and reach their stop limits audibly. In the text above, referring to engine speed being halved, obviously in the case of concrete pumps with electric motor drive the hydraulic pump output will have to be proportionately reduced using the output hand wheel for this purpose.

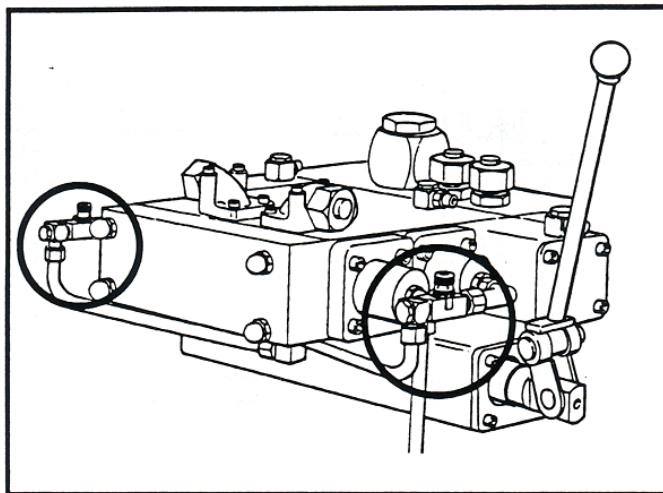

F. Freeing Seized Gate Valves

In service gate valve rods have been known to seize in their housings by progressive buildup of grout and concrete. They can quite easily be freed by closing the locking valve and selecting the concrete pump alternately to pumping and reverse. This means that the differential cylinders are blocked by closure of the valve. The total available hydraulic power will be concentrated into the plungers which are the gate valve operating cylinders, and the gate valves should break free. If the above recommendation fails to free the gate valves or jamming occurs at a later time, it would help

the gate valve assemblies to free themselves if the throttle valves were closed partially. When freely operating, do not forget to readjust the throttle valves as mentioned earlier. If persistent jamming takes place and also occurs where other concrete design mixes are being used and particularly when operating pressures are low, the gate valve assemblies should be checked for mechanical faults such as cracked housings, bowed rods, and finally grout intrusion into the plunger cylinders. Evidence of this should be present in the separator pots adjacent to the plunger cylinders on both sides of the machine.

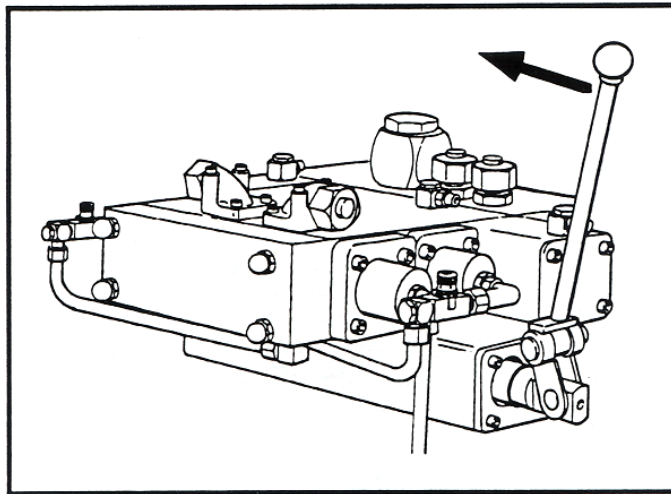

G. Checking Safety Valves

When investigating defects in a hydraulic system, it is important to check that the safety valve itself is functioning properly. First of all you should block the system.

To explain:

- | | |
|-------------|--|
| System I | (concrete pump) |
| | Shut the locking valve. Subsequently close both throttle valves. |
| System II | (agitator) |
| | Jam the agitator shaft with either suitable sized timber or similar. |
| System III | (water pump and compressor circuit) |
| | Shut both water and vent cocks. |
| System IIII | (placing boom) |
| | Close shut-off valve on the jacking cylinders. |

With engine revolutions at maximum or maximum output of the hydraulic pump respectively, the concrete pump, the agitator, the compressor, and the jacking cylinders have to be engaged. Read off and note the safety pressures recorded. Then repeat the tests at half speed or half hydraulic pump output, whichever

applies. If the gauge now indicates a pressure which is more than 10% below the pressure read at maximum revolutions or output, you can be sure that the safety valve is malfunctioning and/or contaminated and has to be replaced.

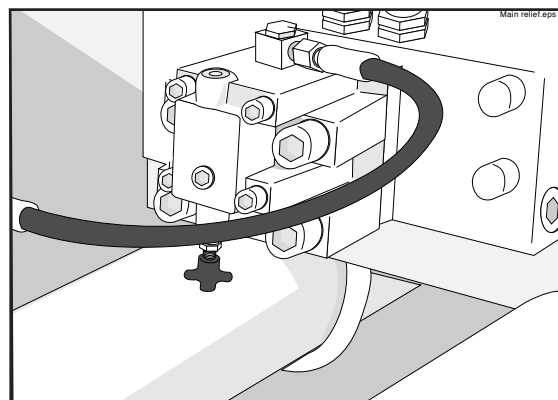
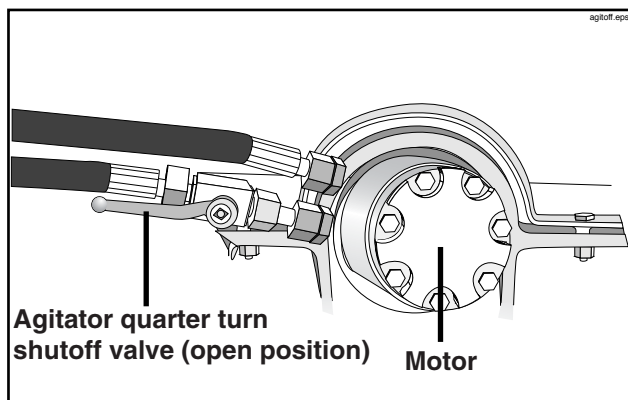

H. Selection and Changeover Operations

When the concrete pump has been selected to pumping (or reversing), all changeover operations are completed automatically, i.e., the valve S2 (serving the differential cylinders) and S3 (serving the plungers) are changed over automatically alternately once from the left and once from the right. The oil flows through the control line to the valve and pushes the selector piston in the valve to opposite sequence - the valve then has been changed over. This flow of oil has a technical term "changeover impulse". For each additional pumping stroke and movement of the gate valve, it is necessary that the corresponding relevant valve switches over. One cycle of the concrete pump consists of four different strokes, they are left-hand pumping stroke, one gate valve stroke, right-hand pumping stroke, and the other gate valve stroke. This means that there are four changeover operations; each of them caused by a changeover impulse. Two of these impulses arise when the left or right-hand cylinder has reached its full stroke position. These impulses changeover the valve S3. When this valve changes over, the impulse for changing over the valve will simultaneously be sent. The impulse transmitters within any one cycle are one from the right-hand differential cylinders and one from the left-hand differential cylinders (to be precise the cylinder heads) and two from the valve S3. Finally the

impulse receivers are the S2 and S3 valves respectively.

Check this against the changeover diagrams in the following pages and also the large size multicolor illustration "the hydraulic twin cylinder system" (available on request). The hydraulic circuit described in the following pages in eight phases applies to all modern SCHWING concrete pumps in the model groupings BPL 450, 600, 800, BP 250, 350, 550 and BP 800 with full hydraulic operation. The eight phases show the four working strokes and the four changeover strokes of the SCHWING concrete pumps. The heavy color lines represent the working or power lines. The dotted color lines represent the changeover or impulse lines. The valve S1 is illustrated in the pumping position and the pressure line of the pump is connected to a pressure gauge (9) with a working range of 0 to 400 bar for pressure checks. There is also a safety valve (10) connected to the pressure line for protecting the hydraulic assemblies. From the safety valve exhaust, the escaping oil flows into the return line and filter (7) back to tank.

There is a bypass valve in the safety valve (10). This valve can be actuated electromagnetically either by direct or remote control. By switching on the valve (11), the hydraulic system will be without pressure, and the concrete pump will be inoperable.

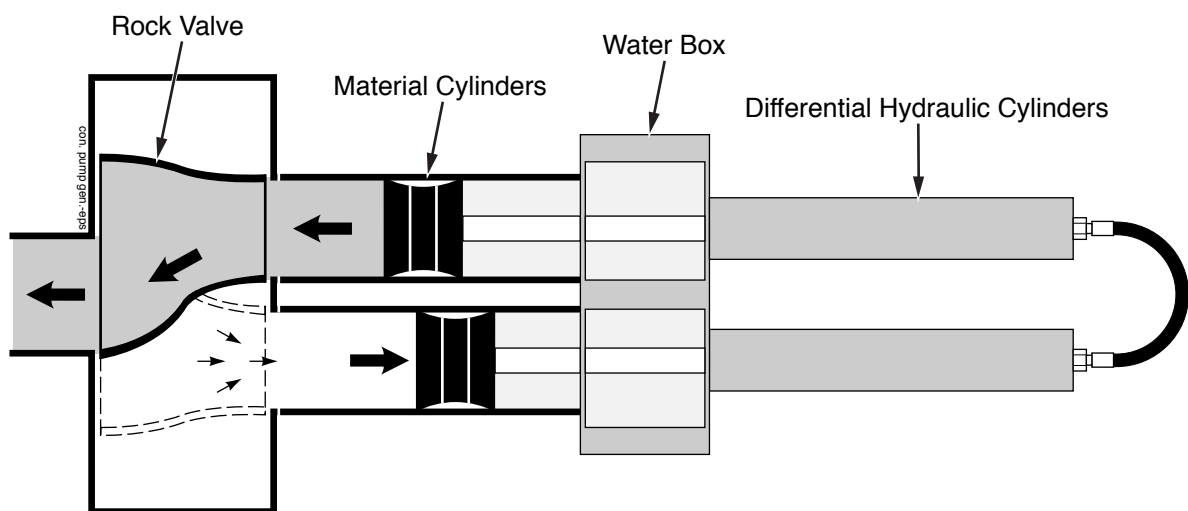

I. Hydraulic Schematic and Sequence Diagrams

1 Switching valve S1	7 Return flow filter	13 Throttle valve
2 Switching valve S2	8 Hydraulic pump	14 Bypass W/Check valve
3 Switching valve S3	9 Gauge	15 Bypass W/Check valve
4 Locking valve	10 Safety valve	16 Bypass W/Check valve
5 Hydraulically unlockable check valve	11 Forward/Reverse handvalve	17 Material gate valve
6 Hydraulically unlockable check valve	12 Throttle valve	18 Hopper gate valve

Legend - Sequence Diagrams 1 thru 8 - BPL 801

The red lines indicate pressure.

The green lines indicate return flow (tank).

The blue lines indicate oil on piston side (compensating oil).

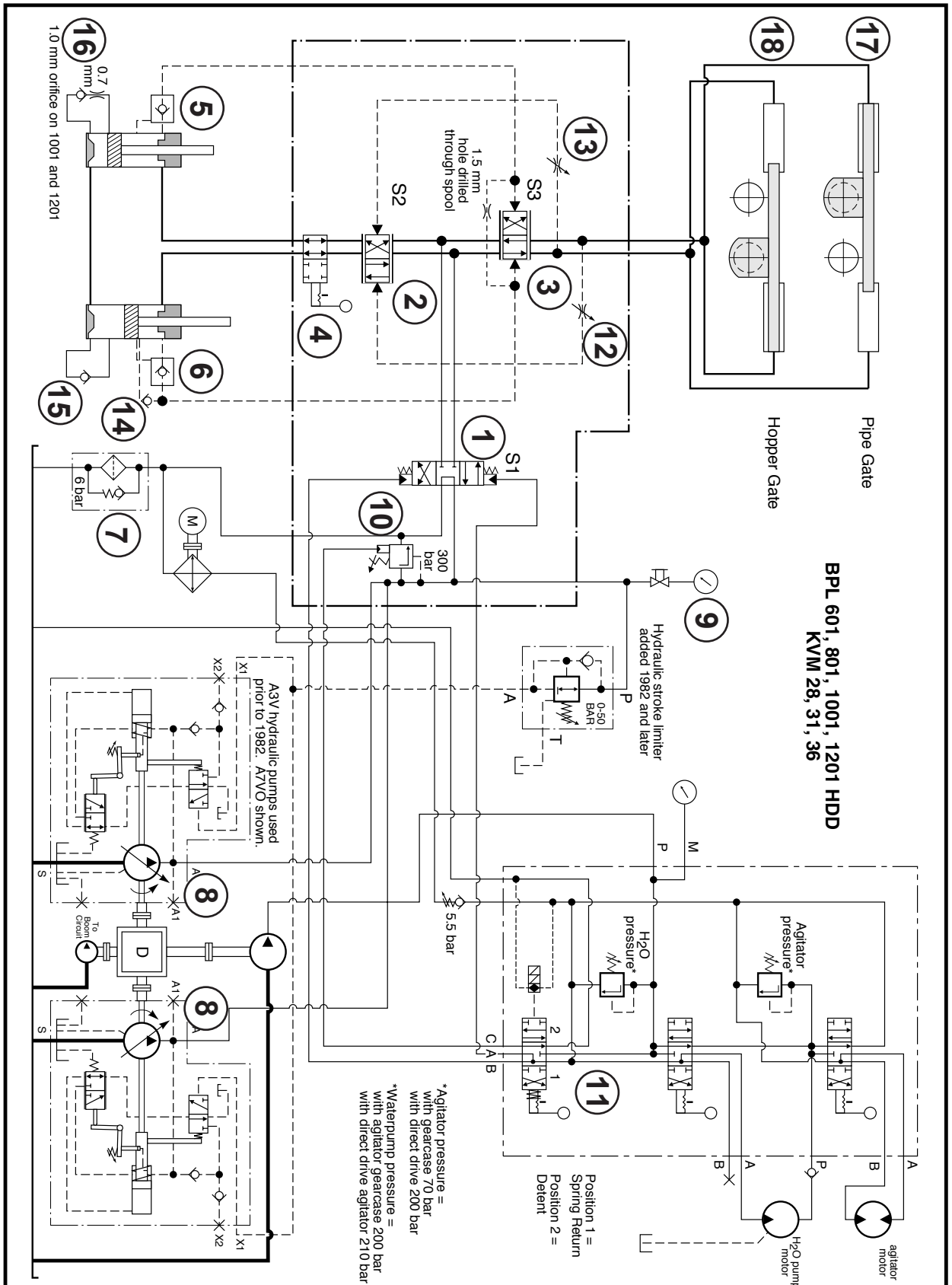

First Working Stroke

With S1 valve (1) in the forward position, locking valve (4) open and S2 valve (2) in the right position pressure oil flows to the left hand differential cylinder acting on the rod side. From the piston side of the left hand differential cylinder oil is passed to the piston side of the right hand differential cylinder and rod side oil of

the right hand differential cylinder is fed back to the tank via valves (4,2,1) and through the filter (7). Oil from S3 valve (3) has the material gate valve (17) held in the left position and the hopper gate (18) held in the right position so that concrete from the right material cylinder is being pushed into the delivery pipeline and the left hand material cylinder is sucking concrete from the hopper.

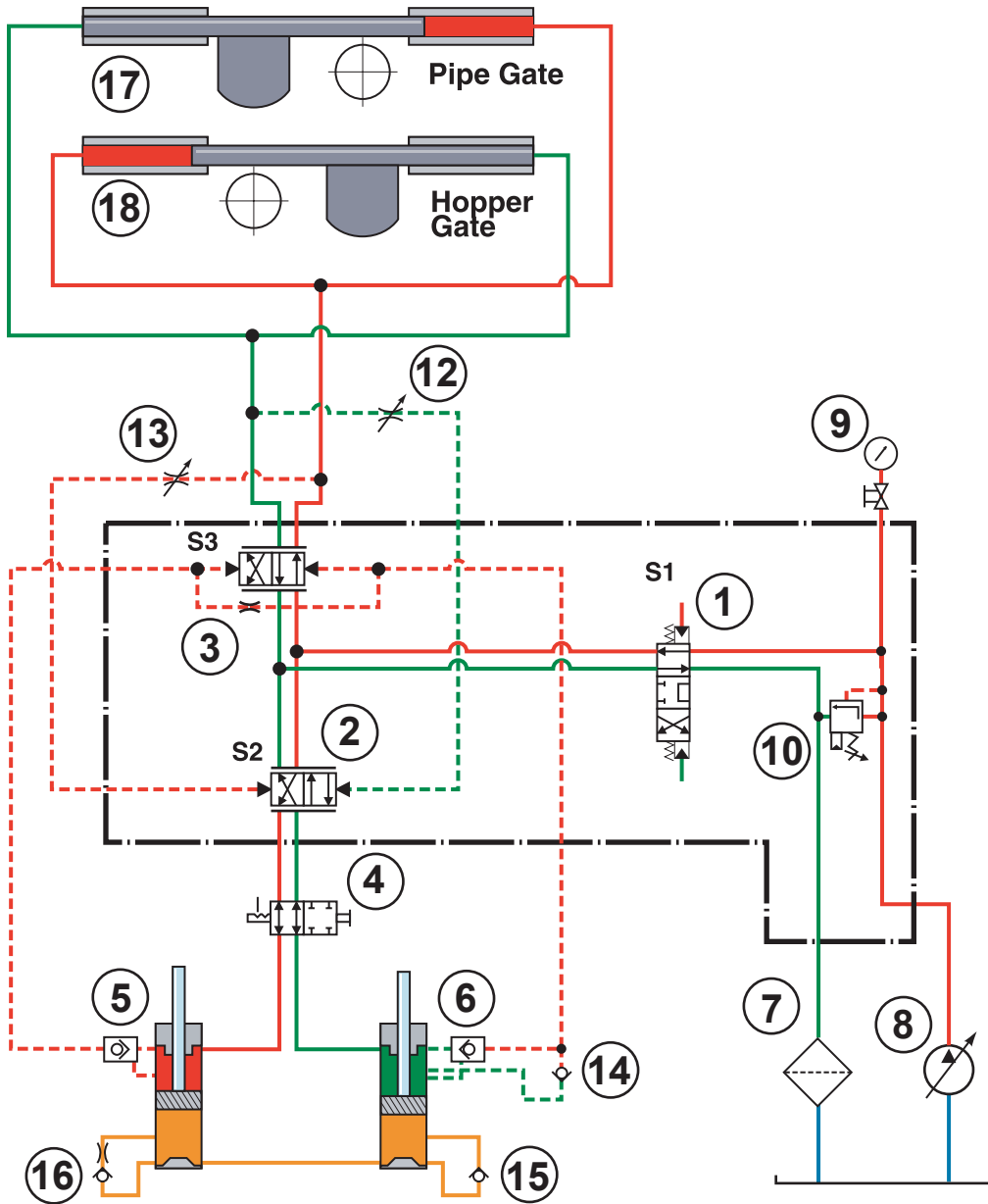

End of First Working Stroke

The differential cylinders have reached the end of their stroke position.* Hydraulically unlockable check valve (5) is sending a high pressure signal to the left hand end cap of S3 valve (3).

NOTE!

If the right hand differential has not fully extended at this point due to not enough loop oil, high pressure oil will continue to flow through check valve (16) on the left hand differential until the right hand differential is fully extended.

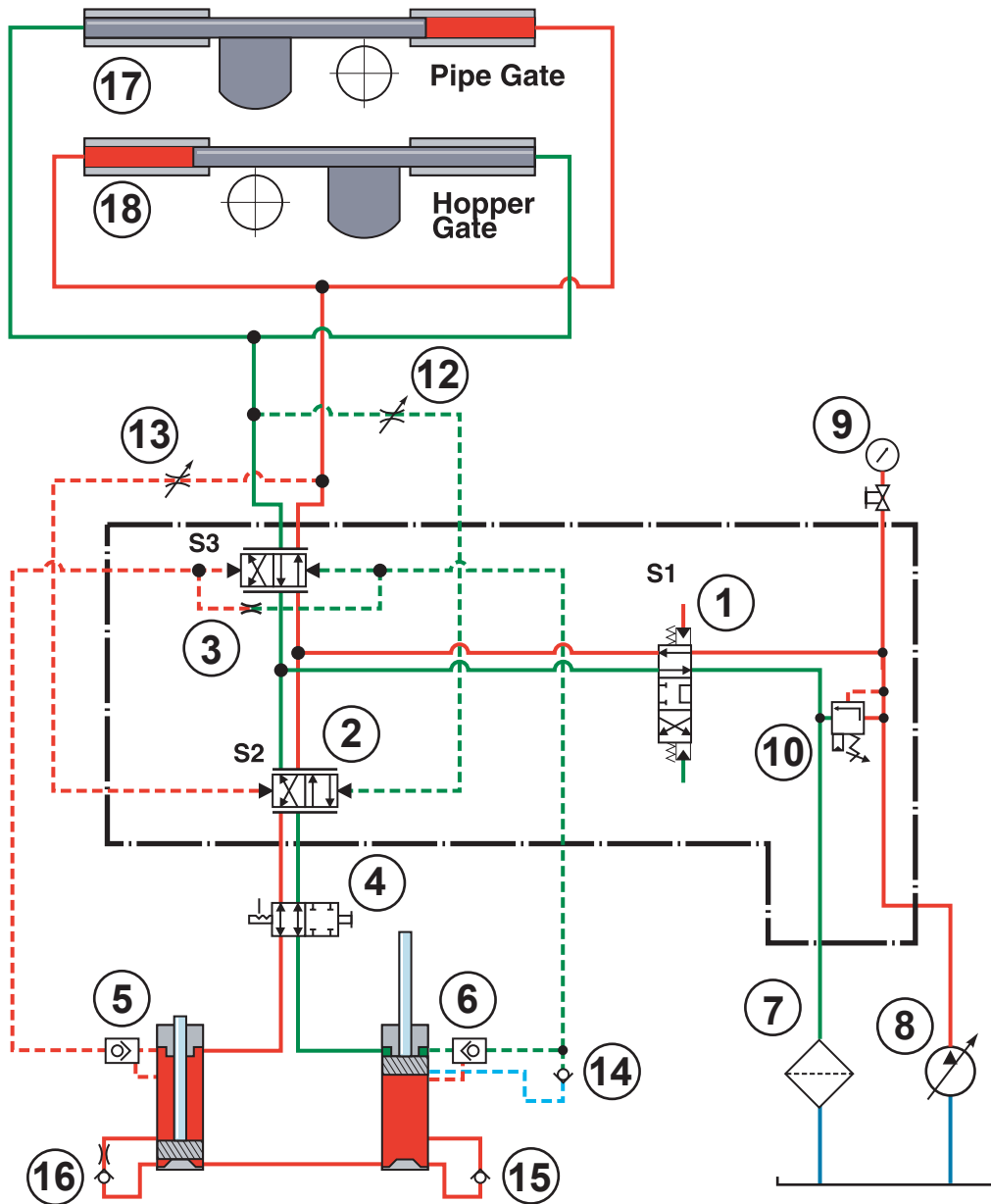

Control Stroke

High pressure oil on the piston side of the right hand differential unlocks the hydraulically unlockable check valve (6) allowing S3 valve (3) to shift to the right. At this point pressure oil to the gate valve is changed and material gate valve (17) is shifted to the right and hopper gate valve (18) is shifted to the left at the same time

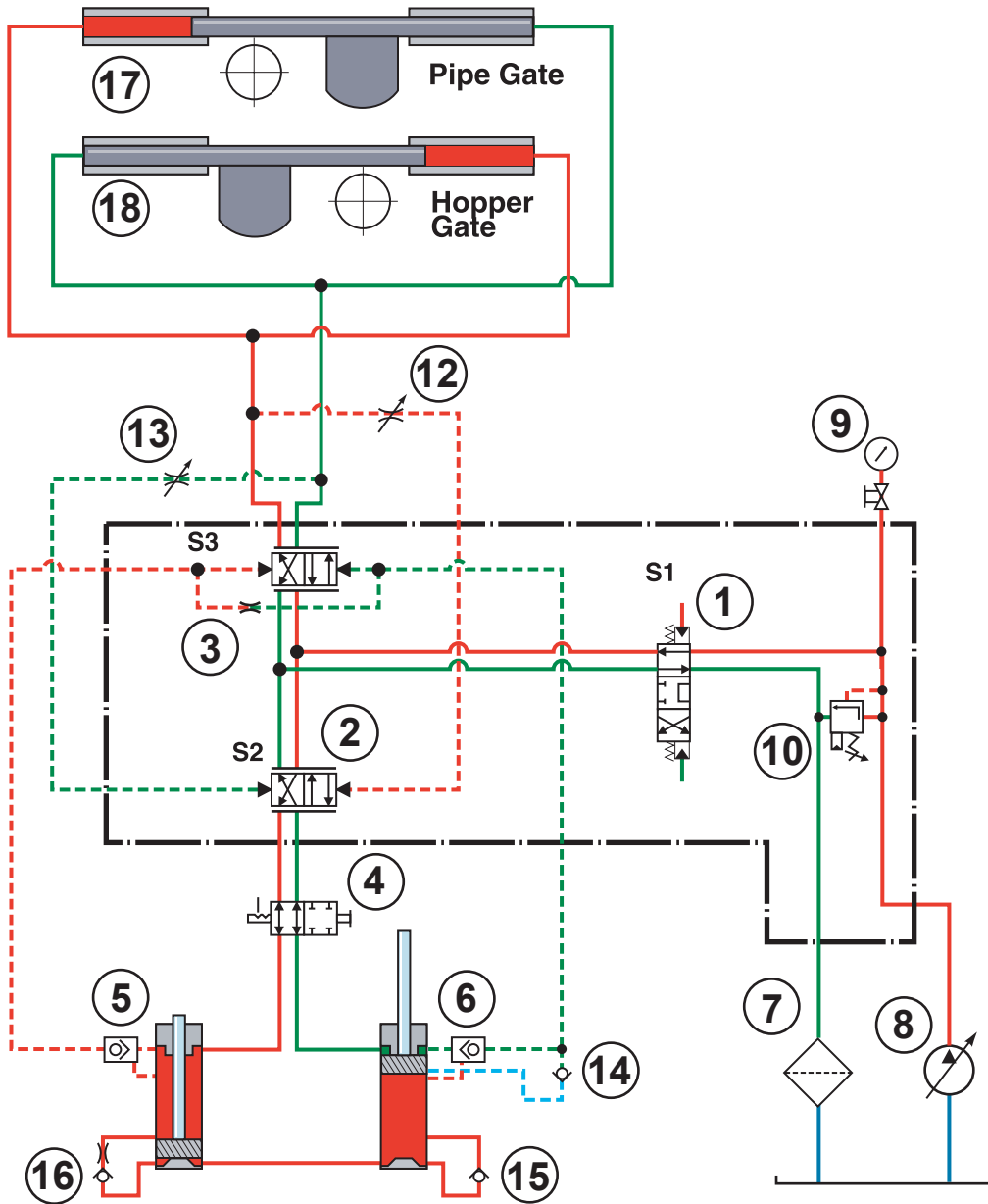

End of Control Stroke

After gate valves (17 and 18) have shifted pressure oil flows through throttle valve (12) to the right hand end cap of S2 valve (2) causing it to shift to the left. Oil on the left hand end cap of S2 valve (2) flows back to the

tank through the throttle valve (13). Pressure oil flowing through S2 valve (2) is now directed to the right hand differential. Check valve (14) must be closed for the right hand differential to move.

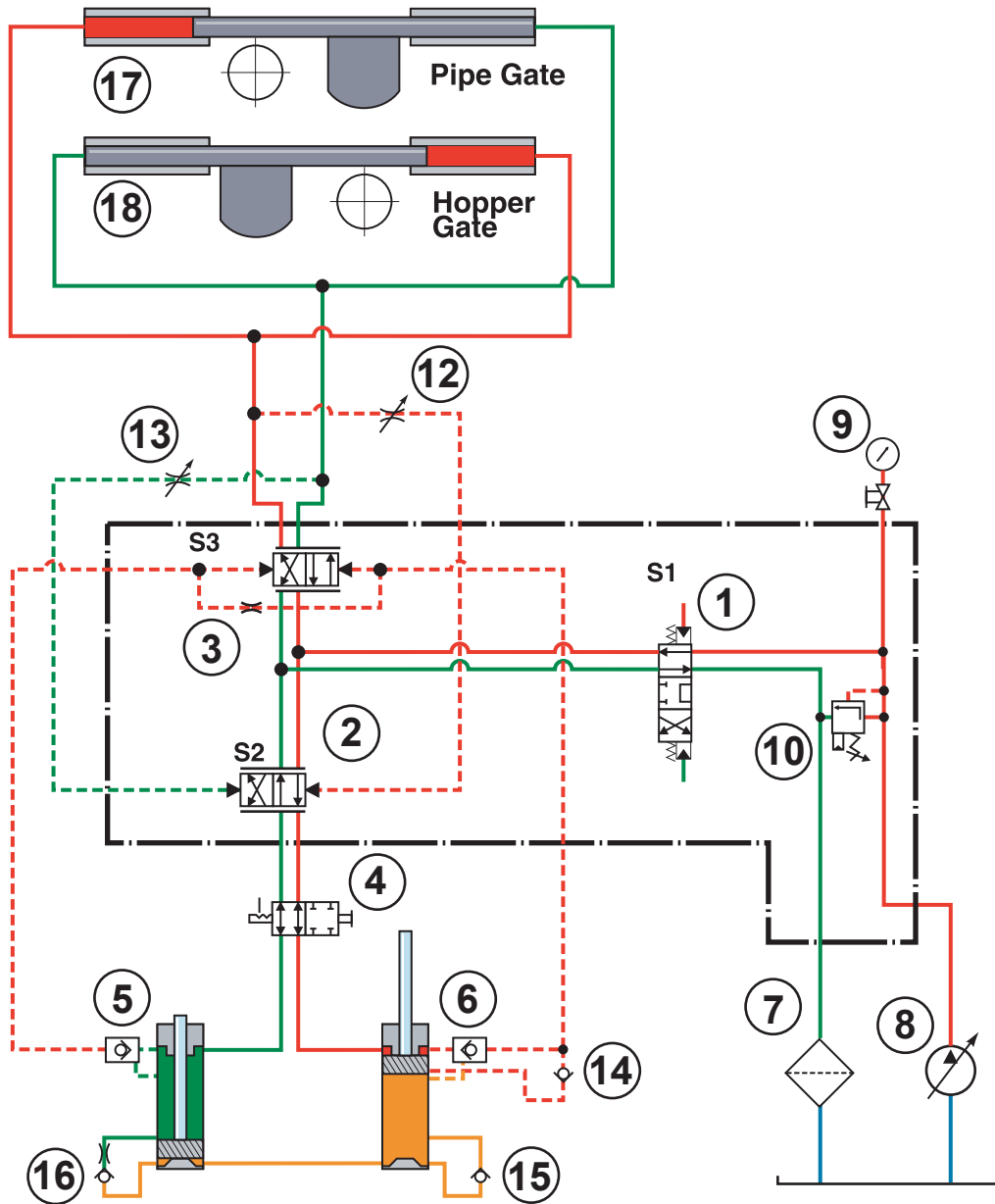

Second Working Stroke

With the S2 valve (2) held in the left hand pressure oil flows through S1 valve (1) and locking valve (4) to the right hand differential cylinder acting on the rod side. From the piston side of the right hand differential cylinder oil is passed to the piston side of the left hand differential cylinder and the rod side oil of the differential cylinder is fed back to tank valve via valves

(4, 2, 1) and through the filter (7). Oil from the S3 valve (3) has the material gate (17) held in the right position and the hopper gate valve (18) held in the left position so that concrete from the left hand material cylinder is being pushed into the delivery pipeline and the right hand material cylinder is sucking concrete from the hopper.

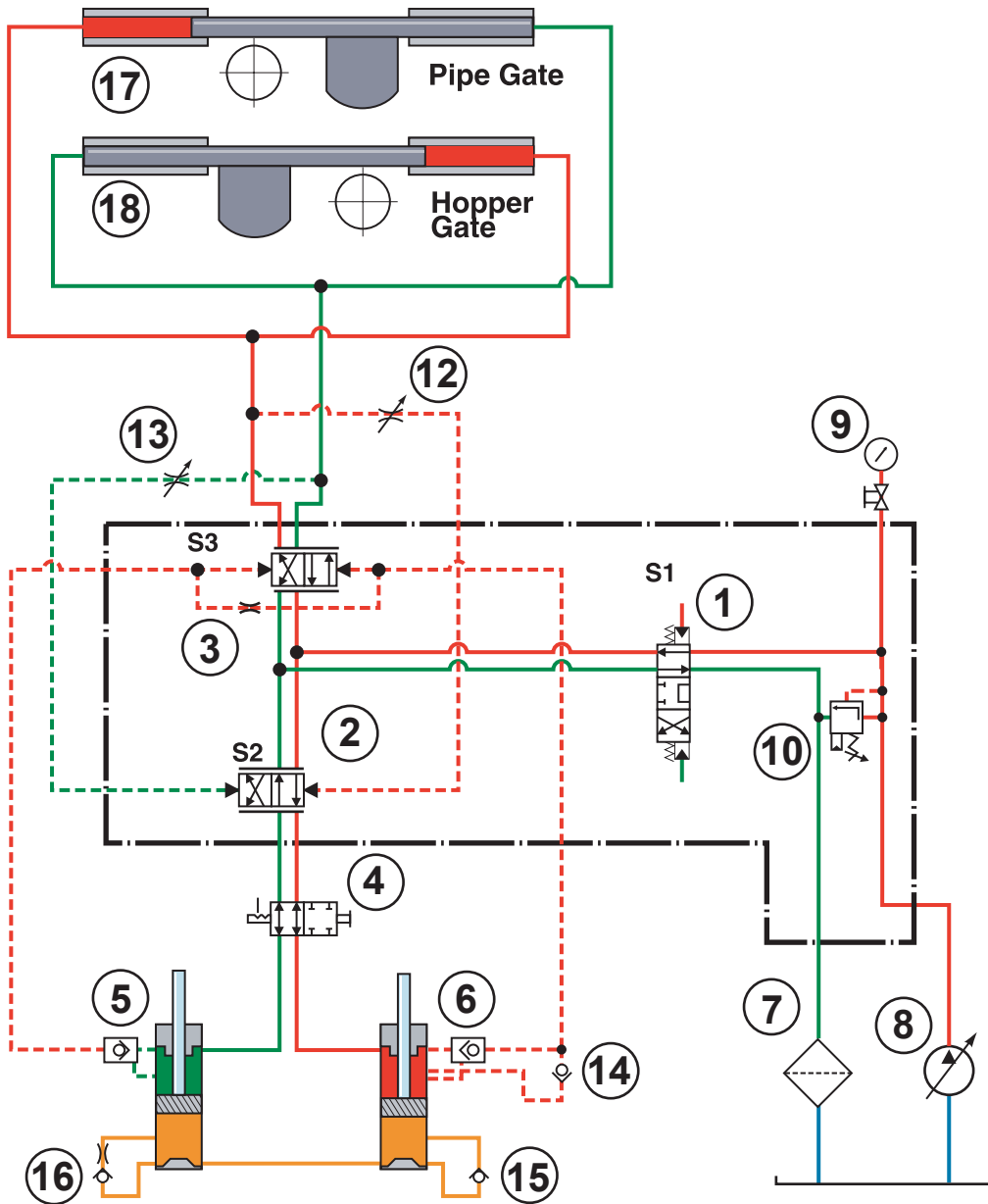

End of Second Working Stroke & Control Stroke

The differential cylinders have reached the end of their stroke. Hydraulically unlockable check valve (6) is sending a high pressure signal to the right hand end cap of S3 (3). If the left hand differential has not fully extended at this point due to not enough loop oil, high pressure oil will continue to flow through the check

valve on the right hand differential until the left hand differential is fully extended. Hydraulically unlockable check valve (5) is unlocked from the high pressure oil on the piston side of the left hand differential cylinder allowing the S3 valve (3) to shift to the left. At this point pressure oil to the gate valve (17) is shifted to the left hand and hopper gate valve (18) is shifted to the right at the same time.

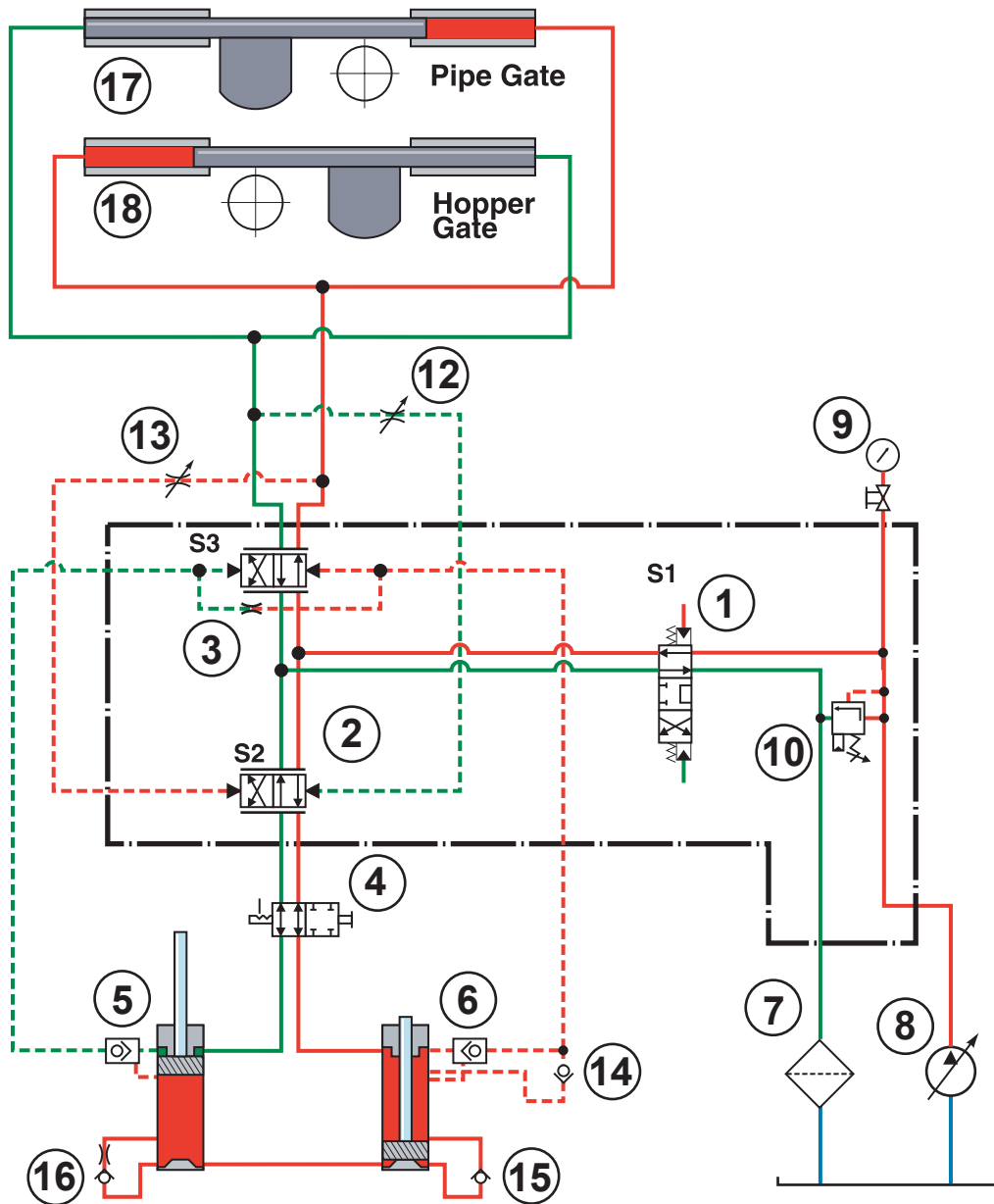

End of Control Stroke & Beginning of Third Working Stroke

After gate valves (17,18) have shifted pressure oil flows through throttle valve (13) to the left hand end cap of the S2 valve (2) causing it to shift to the right, oil on the right hand end cap of the S2 valve (2) flows back to tank through throttle valve (12). Pressure oil flowing through S2 valve (2) is now directed to the left hand differential.

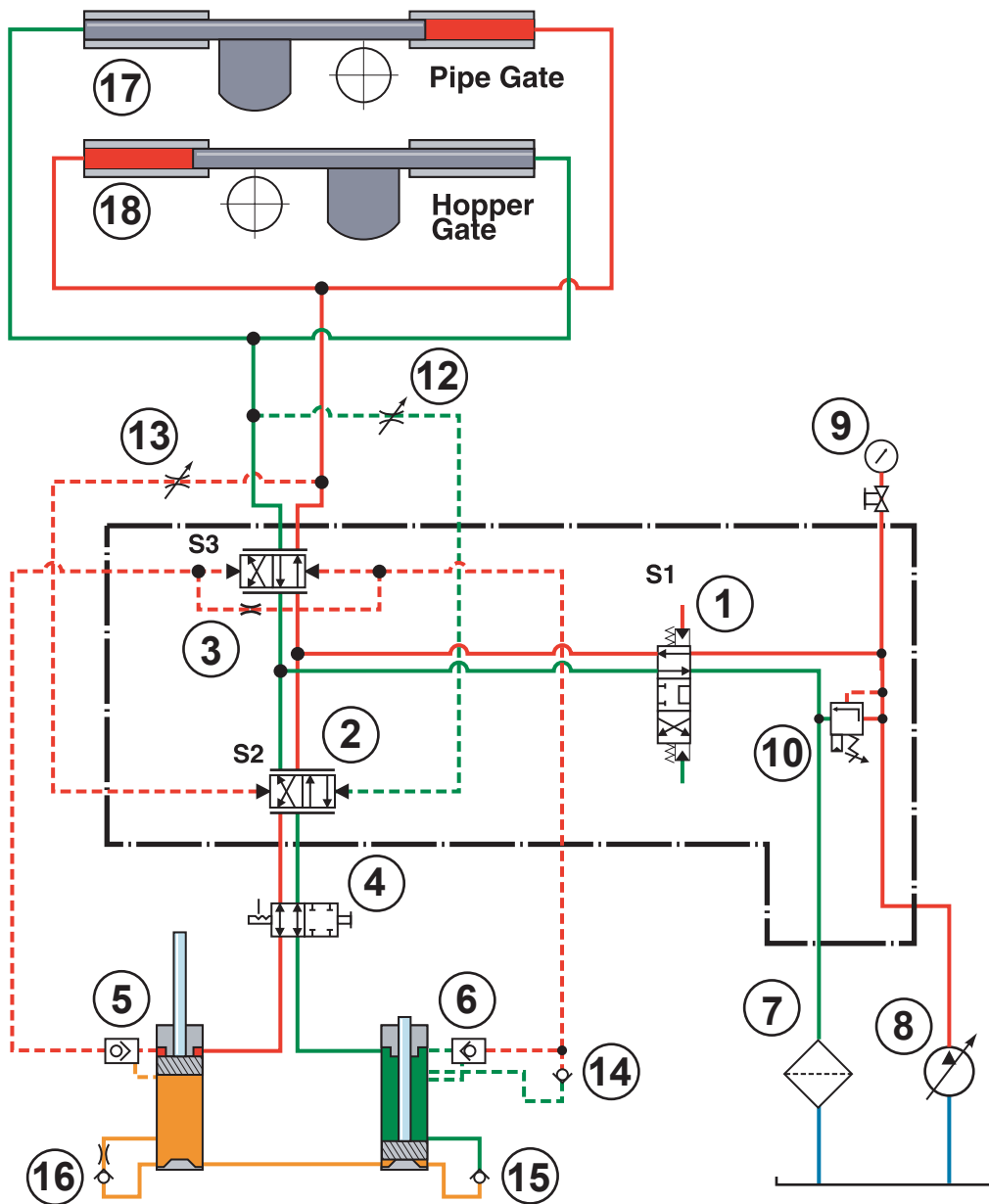

Third Working Stroke

Fig. 8 Valve 3 is in the right position. The pressure oil flows to the right side of the siamese gate valve and simultaneously to the left-hand side of the hopper gate valve pushing the siamese gate valve to the left and the hopper gate valve to the right. From the pressure line,

the oil flows through throttle valve 12 to the right side of valve 2 and moves this valve to the left. The displaced oil from the left side of valve 2 and the left side of the siamese gate valve, as well as on the right side of the hopper gate valve, now flows back to the tank through an interconnected line through valves 3 and 1 and filter 7.

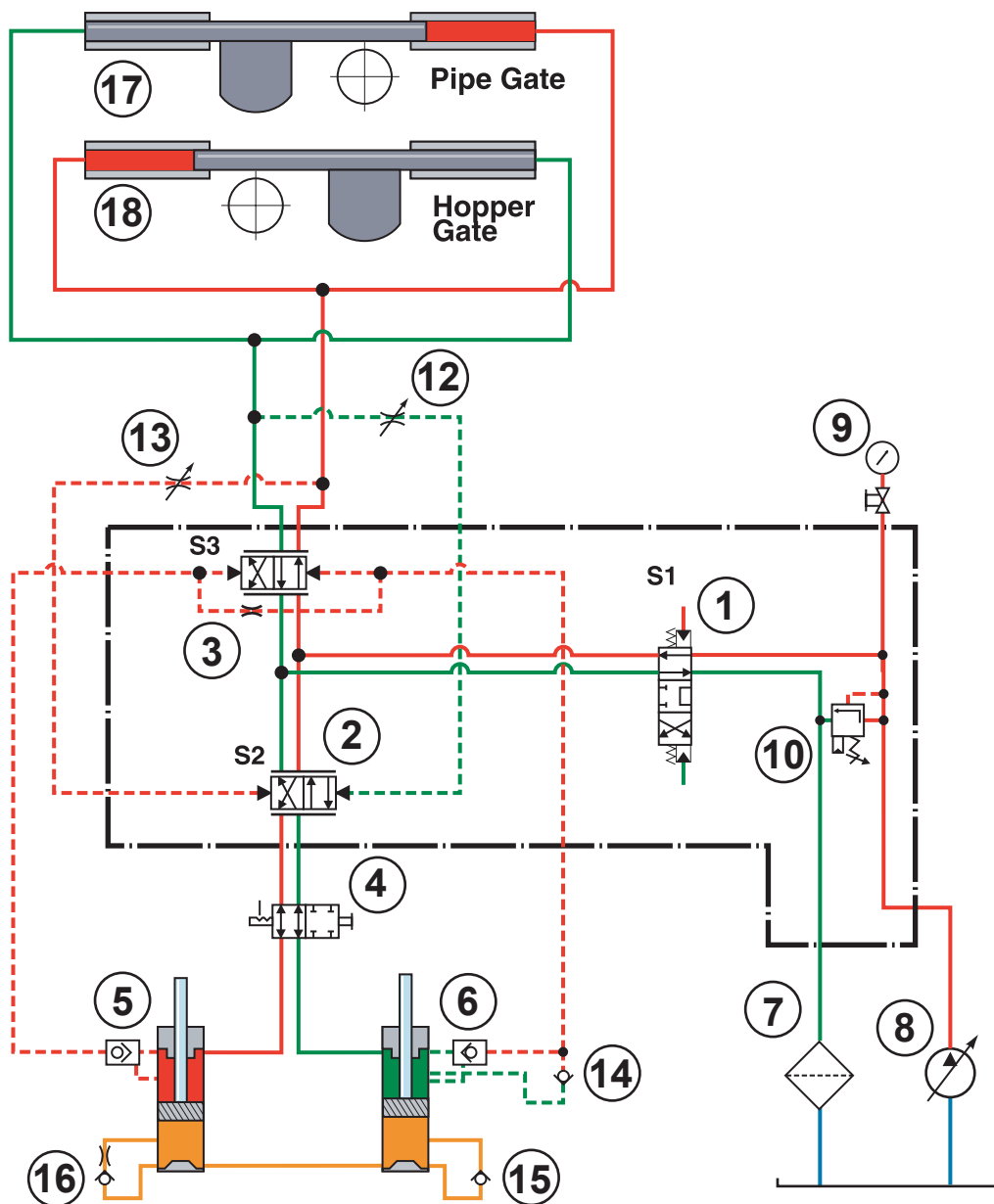

1 Concrete pump does not work, although it is switched on.

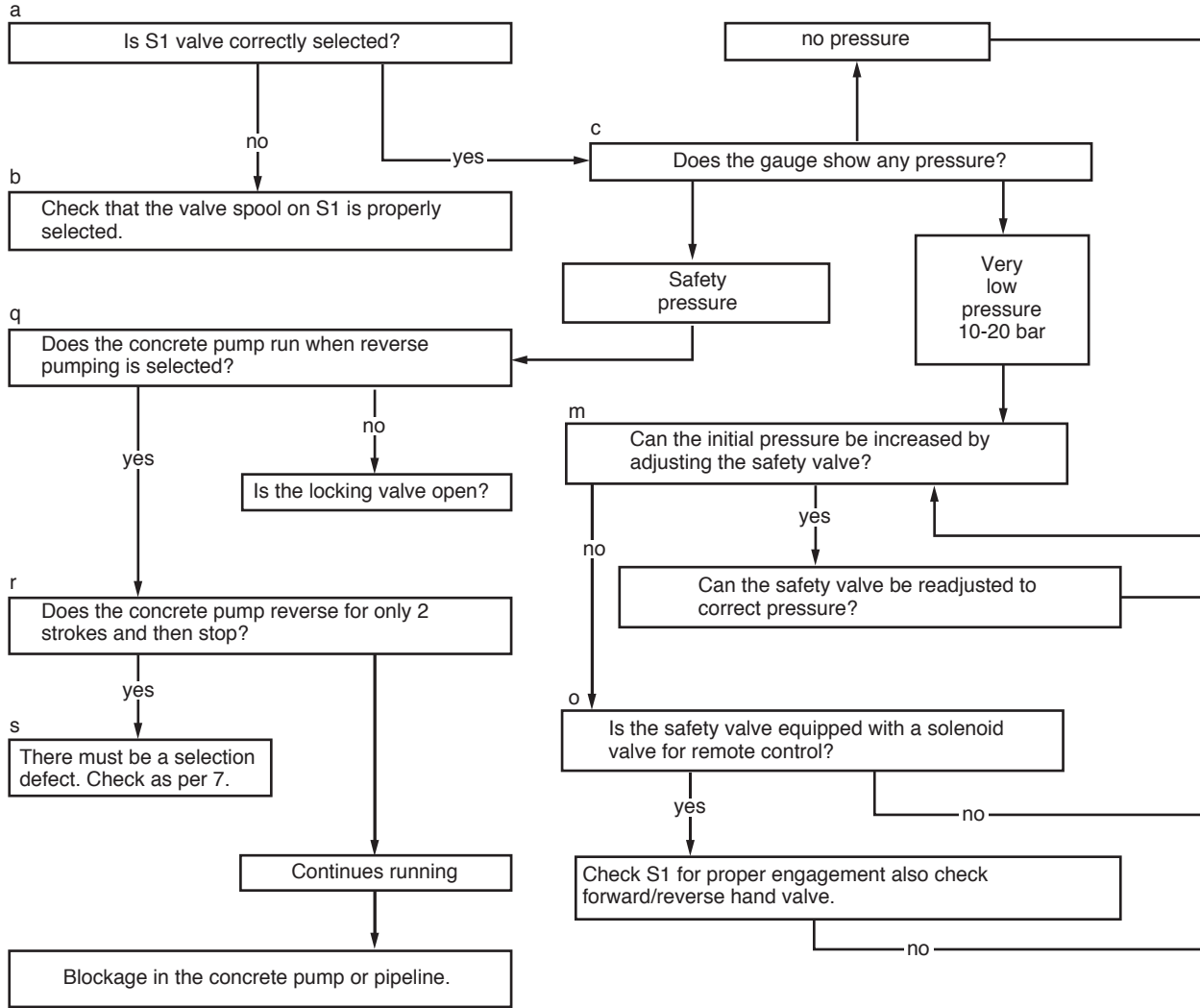

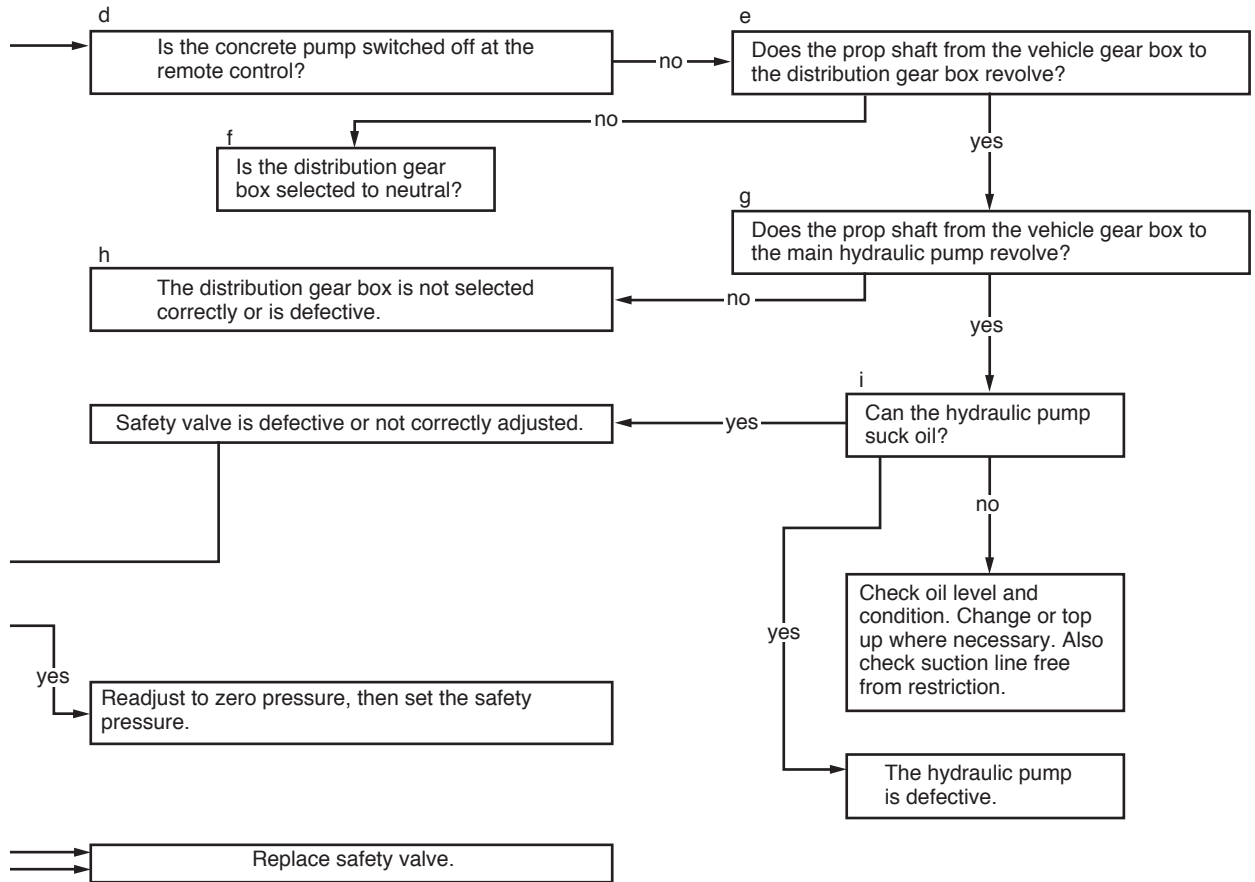

**2 Concrete pump runs very slowly
(few strokes) at very low pressure.**

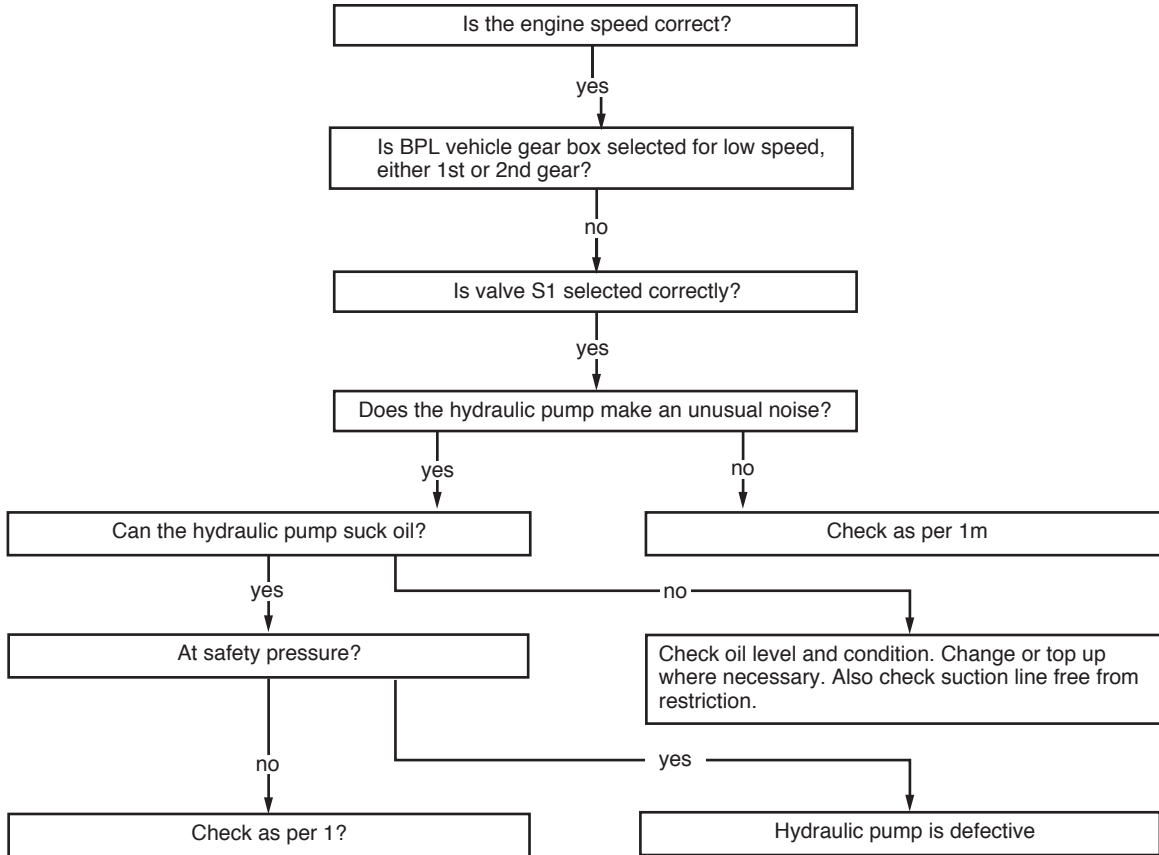

- 3 Concrete pump runs but with unexpectedly high hydraulic pressure. The oil is also heating more quickly than is normal.**

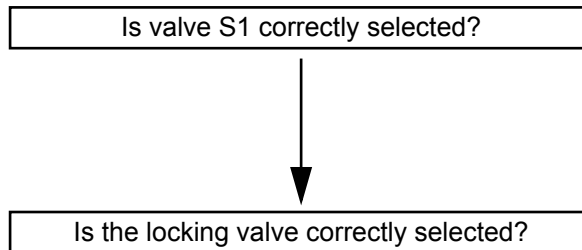

- 4 Concrete pump runs with normal number of strokes. The output is only half as it would correspond to the number of strokes. The gauge alternatively shows one stroke with**

normal pressure and another stroke with a very high pressure. The water level in the water box is rising and falling in the same sequence.

One ram has detached itself from the piston rod. When changing rams, new spring washers must be always used.

5 The concrete pump runs with normal number of strokes. The output is less than would correspond to the number of strokes.

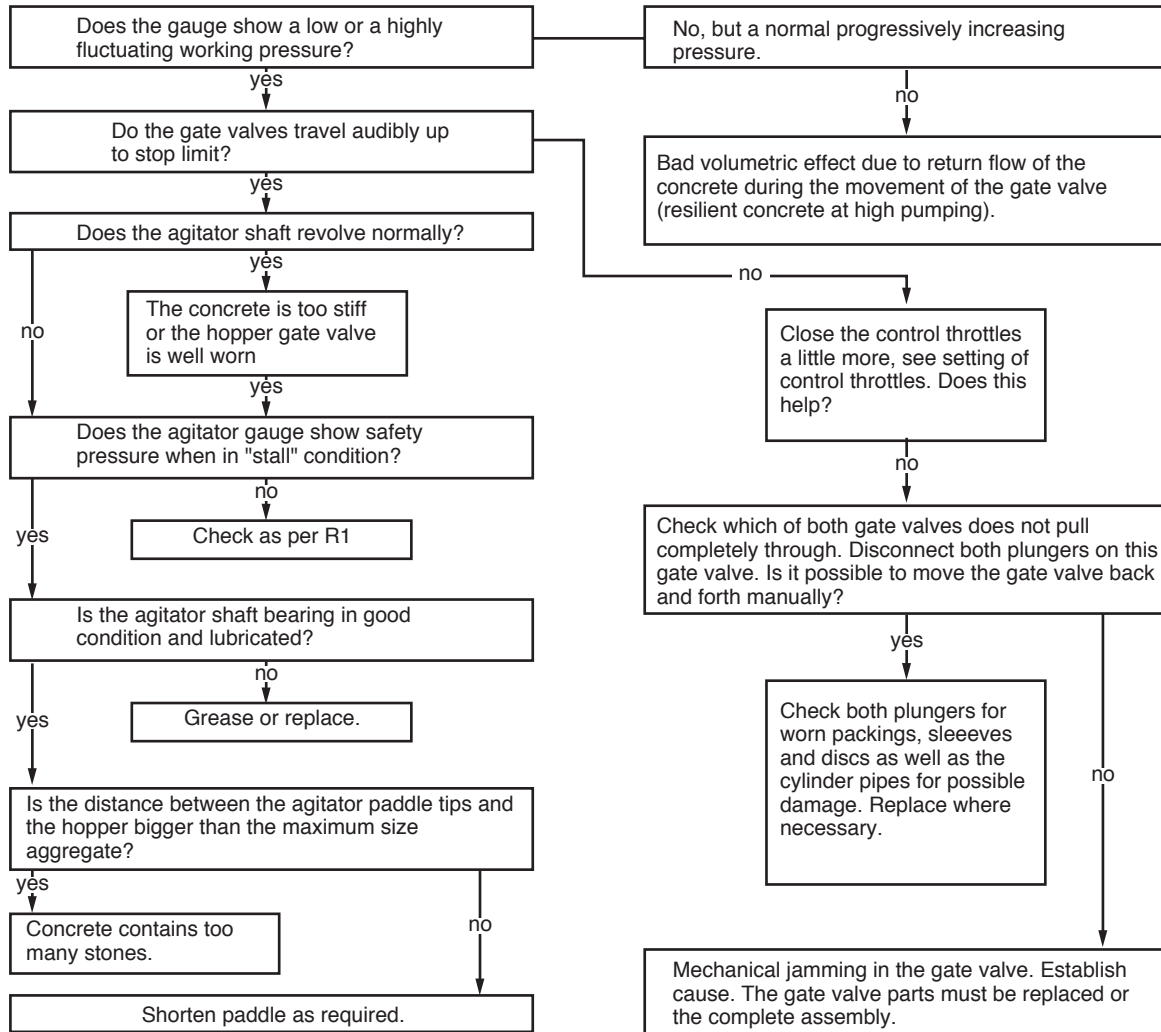

- 6 After every 2nd stroke, the concrete pump stops for a short while. At this time, the gauge indicates safety pressure. On the other stroke, there is no interruption or delay.

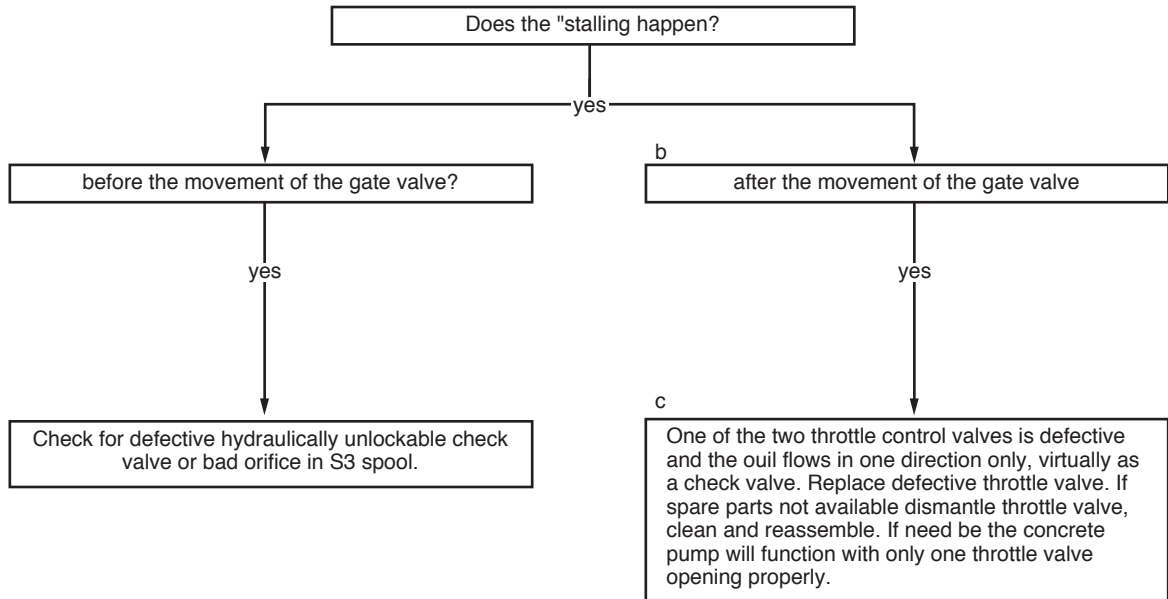

7 The concrete pump stops. The gauge indicates safety pressure. One differential cylinder is in the rear end position, i.e., the piston fixture is close to the rear wall of the water box.

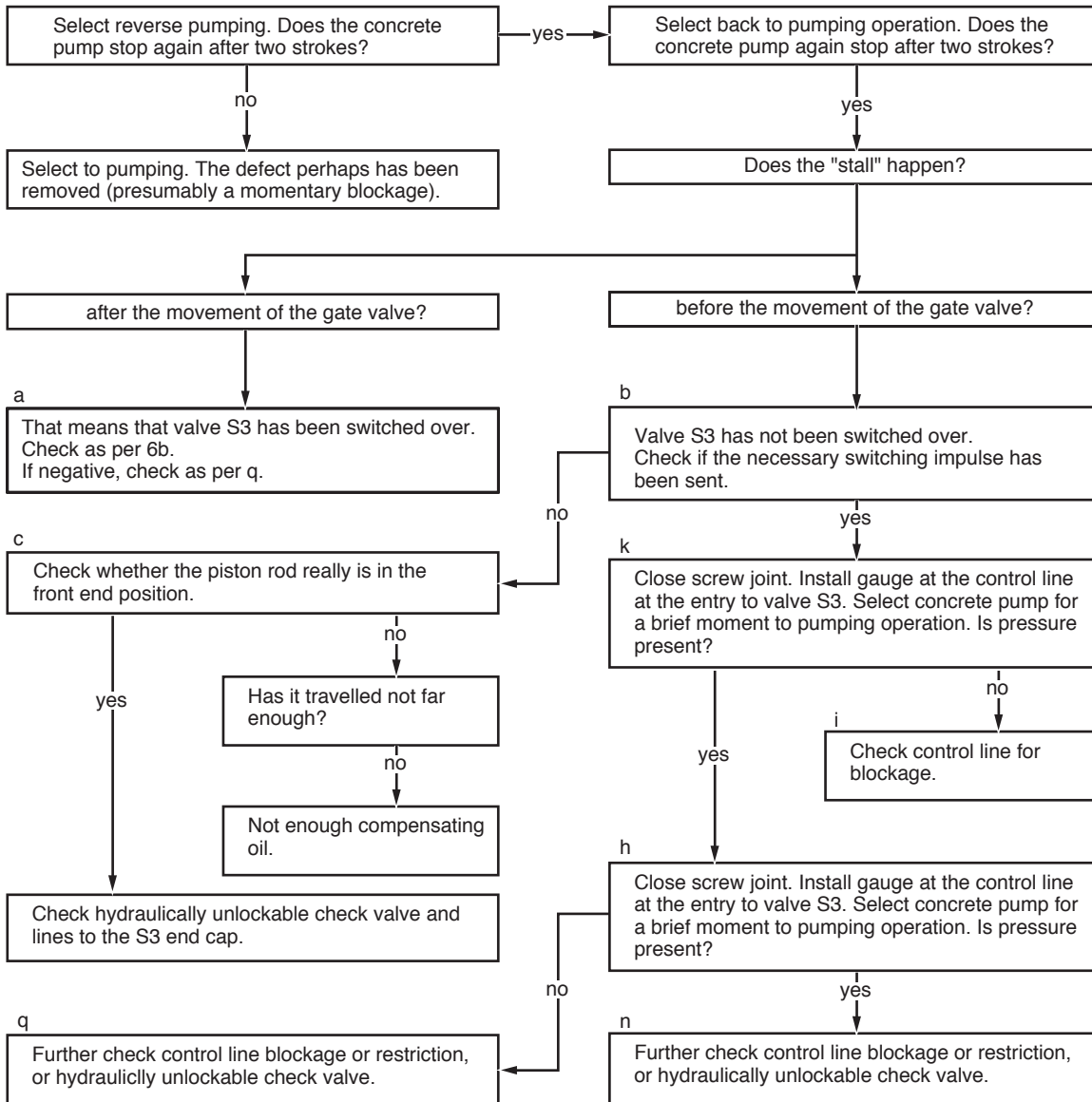

- 8 The concrete pump runs with an excessive number of strokes. It looks as if it is running faster. In fact, it is running at constant speed, but with a shorter stroke. Check the movement of the piston rods in the water box.**

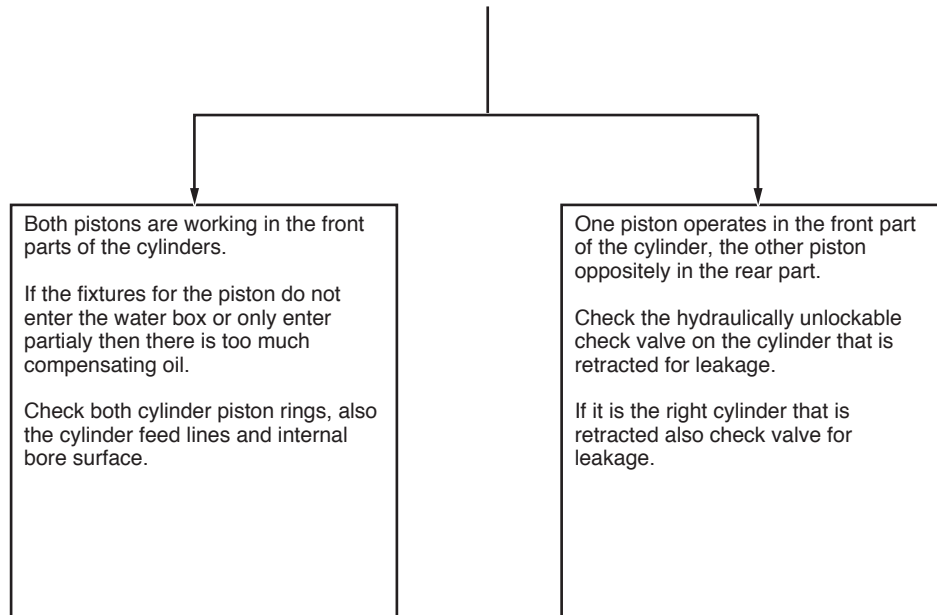

9 After each stroke, the pressure increases in jerks up to maximum safety pressure. The start of the next stroke is retarded for a fraction of a second. Also the hydraulic oil is heated more rapidly than normal.

a. Both throttle valves, or perhaps one, are closed too much. This causes an insufficient quantity of oil to flow to the S 2 valve which tends to

switch over late. Both throttle valves should be opened approximately π of a turn. For full procedure see E (adjustment of throttle valve).

b. Recommendations in (a) do not help - valve S 2 moves with difficulty probably because of foreign bodies between valve and control piston. Remove both end covers, push piston out, see figure Remove all foreign particles and de-burr all edges of piston and valve body.

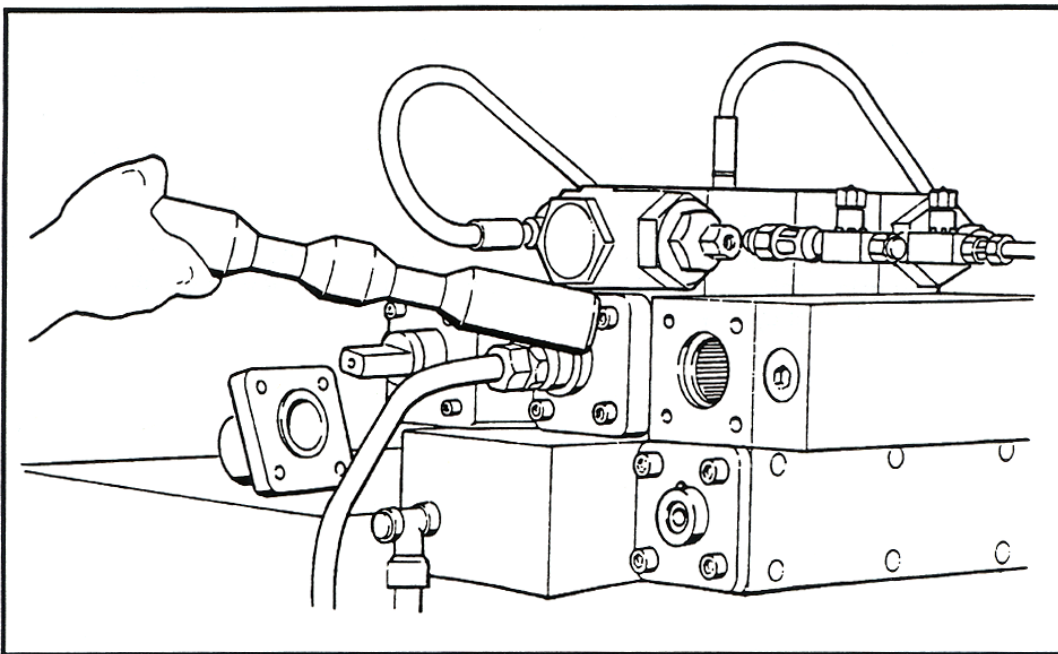

Defects With the Concrete Pump

10 Flushing containers overflow, consequently much higher consumption of flushing agent.

The packings between the gate valve rods and plungers are worn. Renew packing immediately or wear will be accelerated.

11 The hydraulic oil tends to overheat - in excess of 80° C.

- a. The safety valve is set too low and prematurely vents off oil back to tank.
 - Check operation of safety valve (see H 4), replace where necessary.
- b. The lock valve is not fully open.
 - Check position of the piston in the valve body, i. e., where the piston reaches its stop position or where it passes stop position due to damaged circlip. Both conditions will cause a reduction in oil flow apertures.
- c. The S1 valve does not change over properly.
 - Check under 8b. Furthermore, check control rods for deflection or damage.
- d. As under K4.
 - Also check valve S3.
- e. The working pressure is nearly as high as the safety pressure.
 - Reduce pumping speed to reduce the working pressure requirement.

In nearly all cases of excessive oil heating, the number of strokes will be found lower than normally obtained.

Defects With the Placing Boom, Remote Control, and Hydraulic Outriggers

M 1

All boom functions can be selected manually but not with the remote control. Therefore, check the following:

- a. Is the main switch of the remote control on?
- b. Is the cable plug fully pushed into the socket of the terminal box?
- c. Is the ignition key of the vehicle fully pushed into the ignition lock?
- d. Does the gauge for the pre-control pressure indicate a minimum of 6 bar? Where a lower pressure is found, the pre-control valve (spare parts list, boom control block, Pos. 12) has to be readjusted to 7 bar.
- e. Is the fuse in the terminal box in tact?

Should these checks have a positive result, the electric feed line from the vehicle to the switches has to be checked by an electrician in relation to the circuit diagram for faults.

Defects With the Remote Control

M 2

One function can be controlled manually but not with the remote control.

- a. An internal wire in the cable is loose at the terminal block of the distributor box.
- b. An internal wire at the respective switch in the remote control unit is loose or possibly the switch is defective.
- c. An internal wire in the cable is broken. Check with an AVO meter or similar.
- d. The plug contact on the solenoid of the nonworking function is either loose or corroded.

For test purposes, the plug contacts on the solenoid valve of the nonworking motion can be changed using one from a known working motion. If this fails to effect a cure and the first motion still does not function, then the defect has to be traced through the respective solenoid valve or the pre-control valve.

M 3

No boom motion available whether operated manually or by remote control. While the motion is being operated, does the operating gauge register?

- a. Full pressure
 - b. Lower pressure
- a. The constant flow throttle valve belonging to the boom motion in the feed or return line is blocked. Alternatively, the oil from the opposite side of the cylinder cannot exhaust back because the HER safety valve does not open. The spindle of the check piston for the valve is either broken or jammed. Try to actuate the control piston, replace either the piston or the complete valve. (see also M 9)
 - b. The secondary safety valve relevant to the boom motion is maladjusted or defective. Adjust the secondary safety valve (integrated with the HER safety valve) to a higher pressure. If half a turn of the setting pin does not provide a distinct pressure increase, the valve is defective.

M 4

One motion is very slow. Full pressure is available.

The oil from the opposite side of the cylinder can only flow very slowly into the return line. The constant flow throttle valve in the supply or return line of the relevant motion is blocked.

M 5

The gas actuation via remote control does not function. As under M 2. As the speed operation is hydraulically controlled utilizing the pre-control pressure, all hints as under M 1 (d) will apply analogously.

Defects With the Remote Control (cont'd)**M6**

The concrete pump cannot be switched off with the remote control (applicable for machines without speed operation in remote control unit).

- a. The switch on the remote control is defective.
- b. The relay in the distribution box of the remote control is defective.
- c. The cable connections to the switch relay or solenoid valve are loose or corroded.
- d. The small piston pulled by the solenoid in the pre-control part of the safety valve system I - jams.

If a manual emergency device is installed, the piston can be pushed back manually (see photo). If the jamming happens frequently, the pre-control part, including the solenoid valve, should be replaced.

Defects With the Placing Boom**M7**

The lowering movements of the boom or the flyer are jerky. There is then a danger of breaking the boom.

- a. The return oil can escape too fast from the cylinder. The constant flow throttle valve in the return line can be oversized due to wear. Refer to the circuit diagram to obtain correct diameter of the throttle assembly.
- b. The hydraulic pump is not fed in sufficient quantity and, therefore, the effected cylinder side cannot be replenished in the required time. Check the oil tank level and suction line.

Defects With the Placing Boom (cont'd)

M8

Boom or fly assembly creep down slowly even though the motion has not been selected.

The HER safety valve on the relevant cylinder side does not close fully or properly. It must be checked whether the leakage occurs on the check valve or on the secondary safety valve. To do this, the boom must be brought into a position where the weight of the boom produces pressure in the relevant cylinder side. Simply arrange that the boom can still be in a position to creep down slowly, but the HER valve is accessible for dismantling and assembly purposes. The pressure line of the leak line should be loosened. The leakage line is in fact where uniform flow of oil occurs when the boom is being lowered.

- a. Oil seeps from high pressure connection. The check valve is no longer oil tight. Remove the HER safety valve from the cylinder. Having removed the locking screw, position 9, remove the pressure spring and ball. Clean the ball bearing, re-insert ball, and strike same fairly strongly using a copper drift and hammer. Reassemble and install the valve.
- b. Oil seeps from the leakage oil pipe connection. This means a secondary safety valve is set too low. As soon as the pressure pin (Pos. 20) is

screwed in by π to f turn, the oil leakage and secondly the creeping of the boom should stop. However, if oil still seeps out, check the effectiveness of the cone in the seating. Before removal of the safety valve, the boom must be supported in order to depressurize the cylinder.

The HER (hydraulically unlockable check valves) prevent the boom lowering in jerks should the high pressure line break. However, during the downward motion the oil must be able to flow from the cylinder. For this purpose, the check valve must be open, and this happens when oil is conveyed to the opposite side of the cylinder and this pressure (min. 30 bar) opens the check valve via a piston (Pos. 8).

The secondary safety valves protect the cylinder against excess pressure, particularly when the oil pressure is added to the static pressure generated by the weight of the boom from the opposite cylinder side. Both pressures accumulate and would influence the efficiency and reliability of the cylinder and cylinder seals, if it were not for the secondary safety valves ability to absorb the excess pressure. Therefore, the secondary safety valves must not be set to any desired pressure.

For precise adjustment, remove the locking screw (Pos. 3) on HER safety valve and connect the pressure gauge. This gauge must show a measuring range of min. 400 bar. For the correct pressure setting see the circuit diagram.

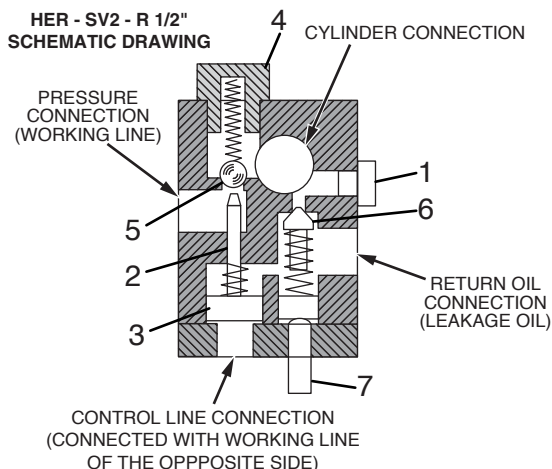

1. Gauge port plug
2. Spindle for control piston
3. Control piston
4. Locking plug for check ball and spring
5. Check ball and spring
6. Secondary safety valve
7. Pressure Pin

HYDRAULIC SCHEMATIC - KVM 28 BOOM

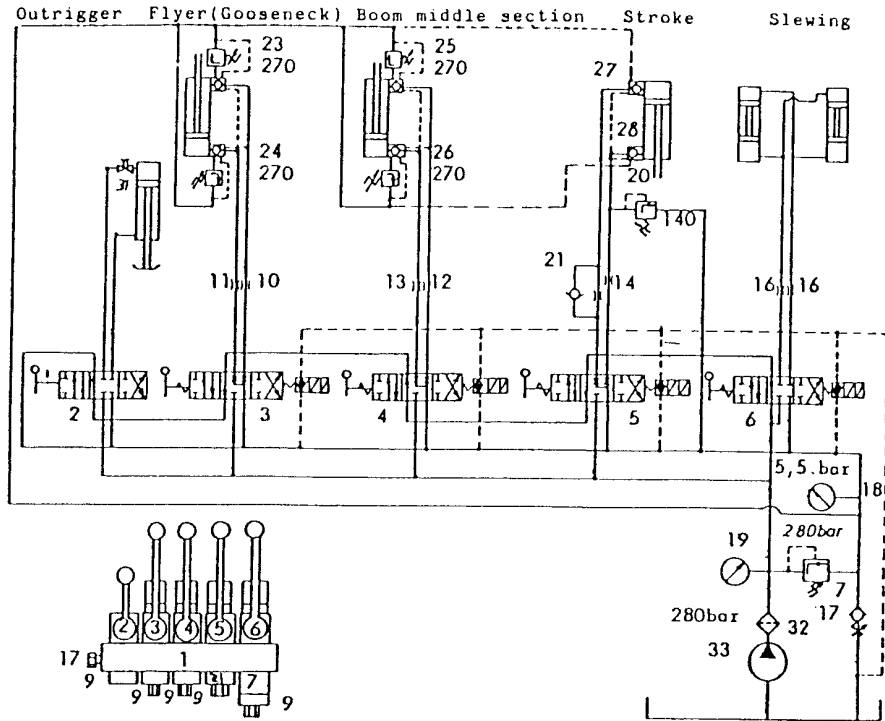

Pc.	Description
1	Base plate
2	Gate valve HSR 10631
3	Gate valve HVM 10632F
4	Gate valve HVM 10632F
5	Gate valve HVM 10632F
6	Gate valve HVM 10631
7	Pressure limit valve DVP-P-10 S
8	End plate
9	End plate
10	Nozzle 1.0 mm B REAR
11	Nozzle 1.3 mm C FRONT
12	Nozzle 1.3 mm C REAR
13	Nozzle 1.7 mm D FRONT
14	Nozzle 1.7 mm D REAR
15	
16	Nozzle 1.3 mm C REAR
17	Pre-load valve VV-2R3/4"
18	Piston gauge 0-16 bar=0-228 psi
19	Piston gauge 0-315 bar=0-4470 psi
20	Pressure limit valve SVL-R3/8"
21	Throttle check valve SRD 10 A1,5/B10F
22	
23	Hydr. unlock. check valve HER SV2-R $\frac{1}{2}$ "
24	Hydr. unlock. check valve HER SV2-R $\frac{1}{2}$ "
25	Hydr. unlock. check valve HER SV2-R $\frac{1}{2}$ "
26	Hydr. unlock. check valve HER SV2-R $\frac{1}{2}$ "
27	Hydr. unlock. check valve HER 4-R $\frac{1}{2}$ "
28	Hydr. unlock check valve HER 4-R $\frac{1}{2}$ "
29	
30	
31	Screw down valve
32	Pressure filter
33	Hydraulic pump

BPL 801 ELECTRICAL SCHEMATIC

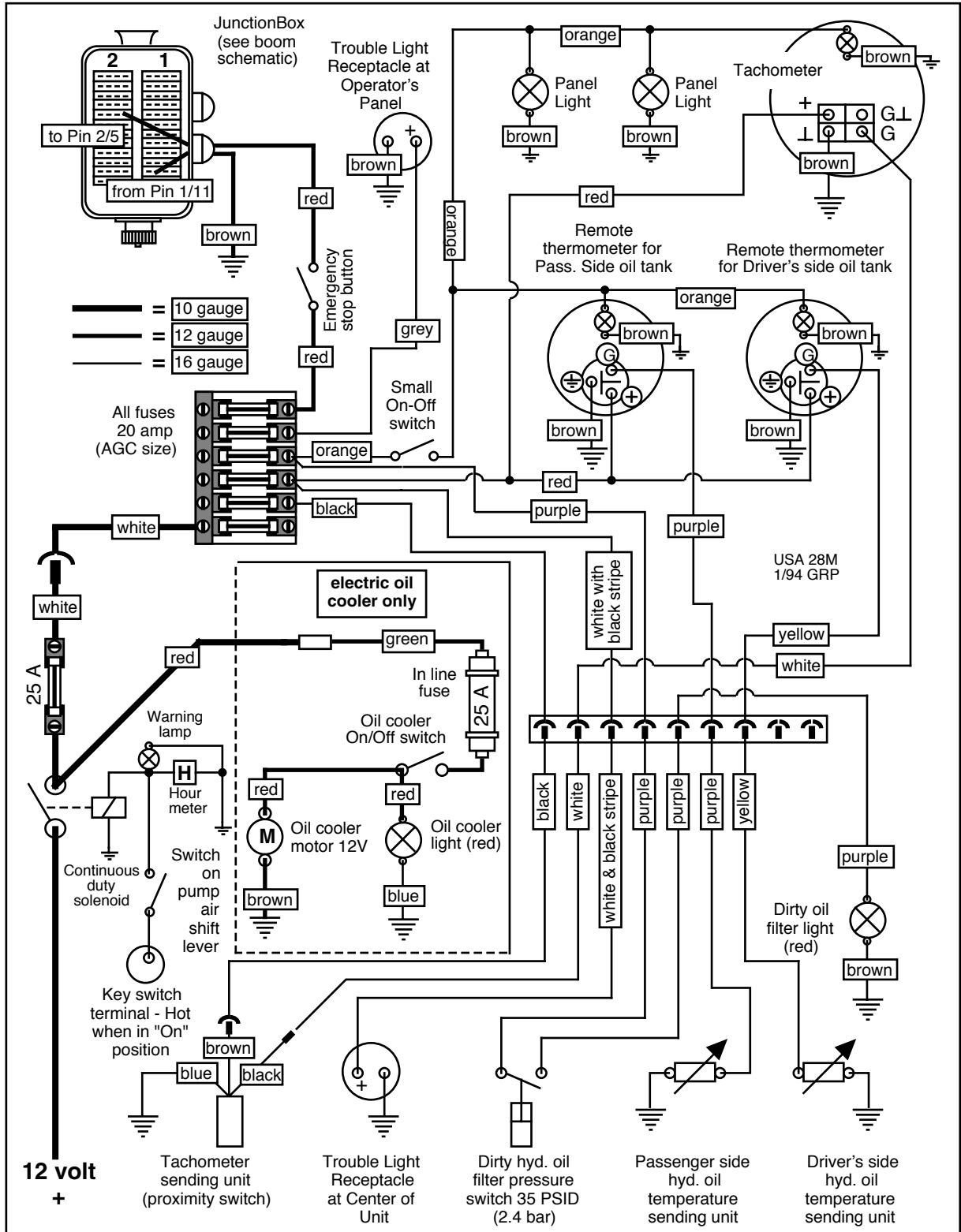

BPL 801 ELECTRICAL SCHEMATIC

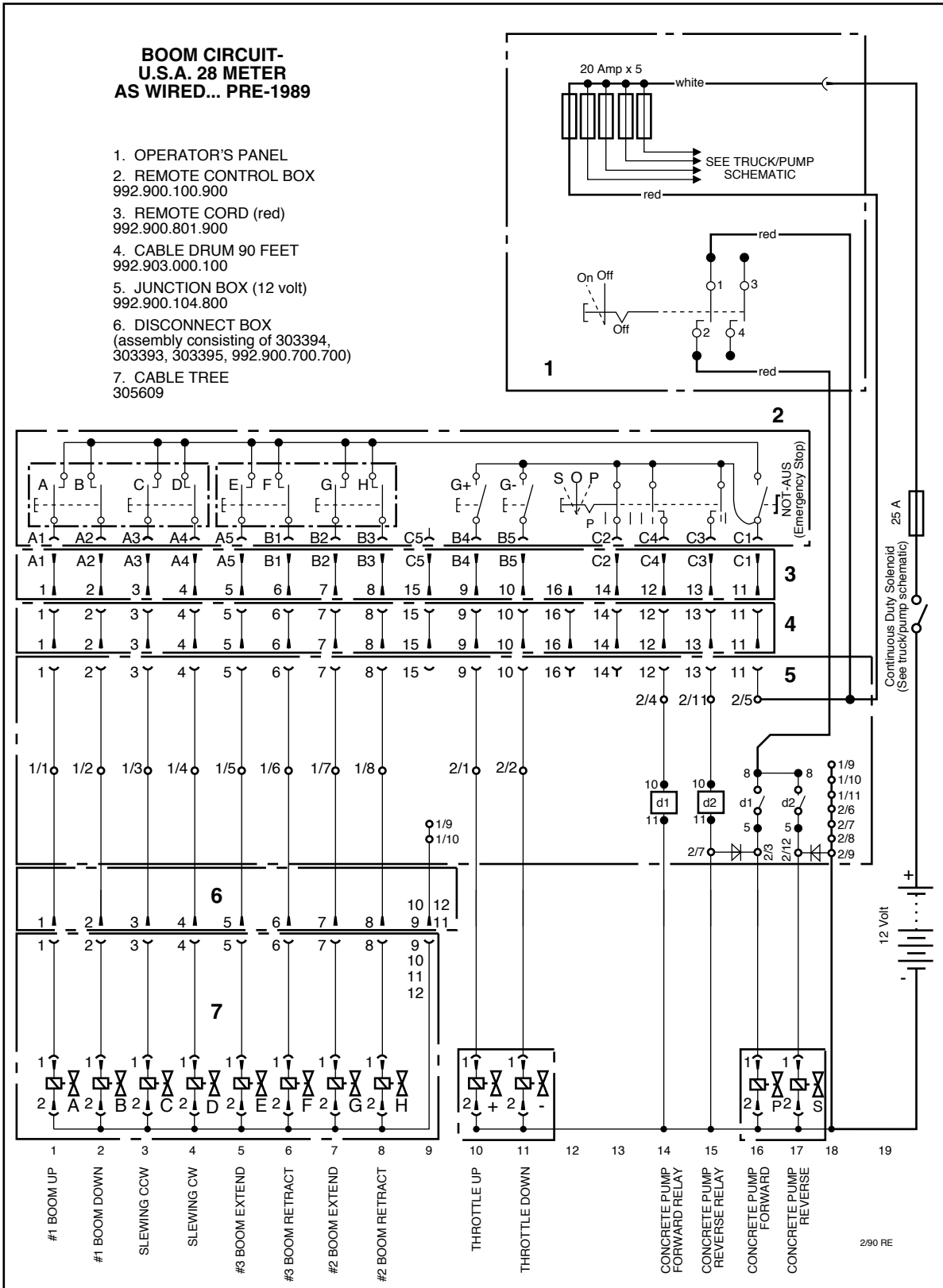

R1 The agitator stops frequently and can only be set in motion again after reversing briefly.

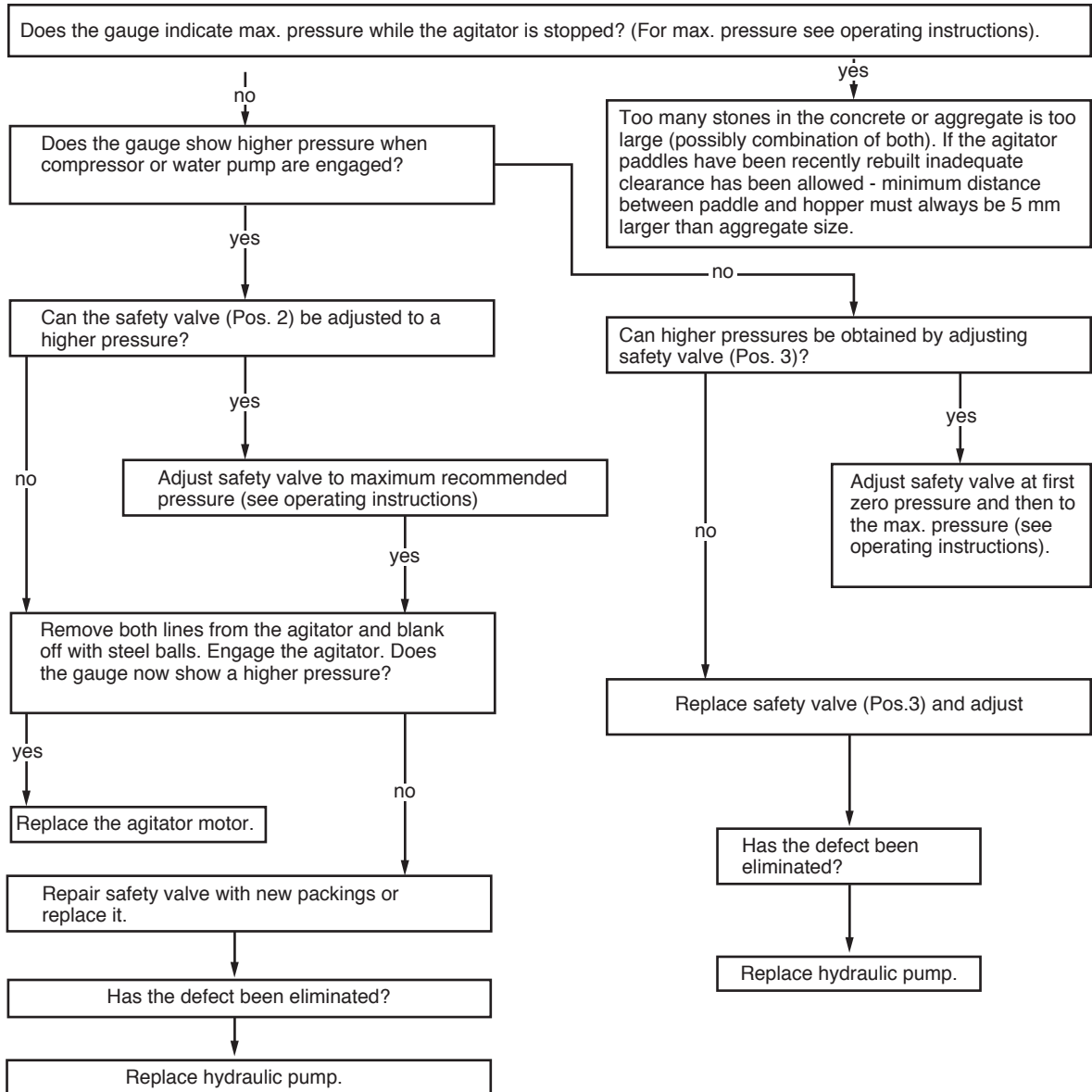

R2 The agitator runs with unexpectedly high pressure.

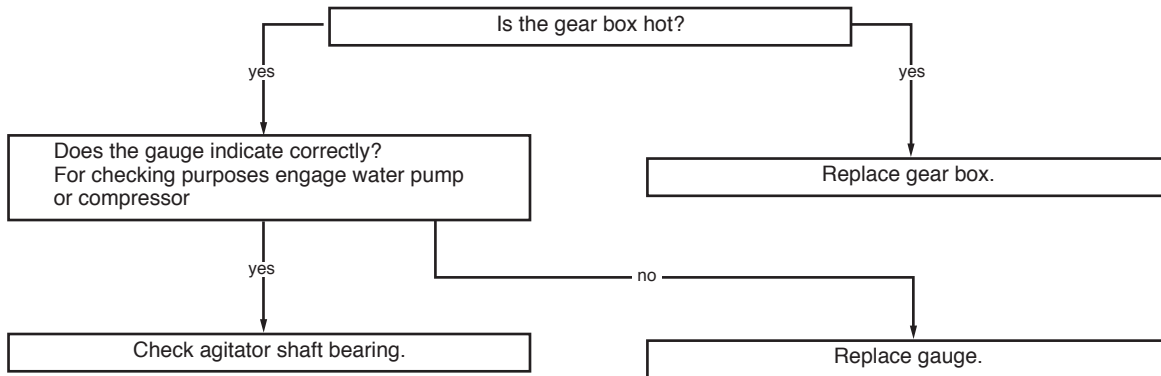

Hydraulic circuit diagram, agitator, compressor, water pump, forward reverse

1. Base plate EV 192.001
2. Safety valve cartridge SVP-10
3. Safety valve cartridge SVP-10
4. Hand gate valve HSR 10 632
5. Hand gate valve HSR 10 632
6. Hand gate valve HVM-ROL 10632
7. Check Valve
8. Pre-load valve VV-2-R 3/4

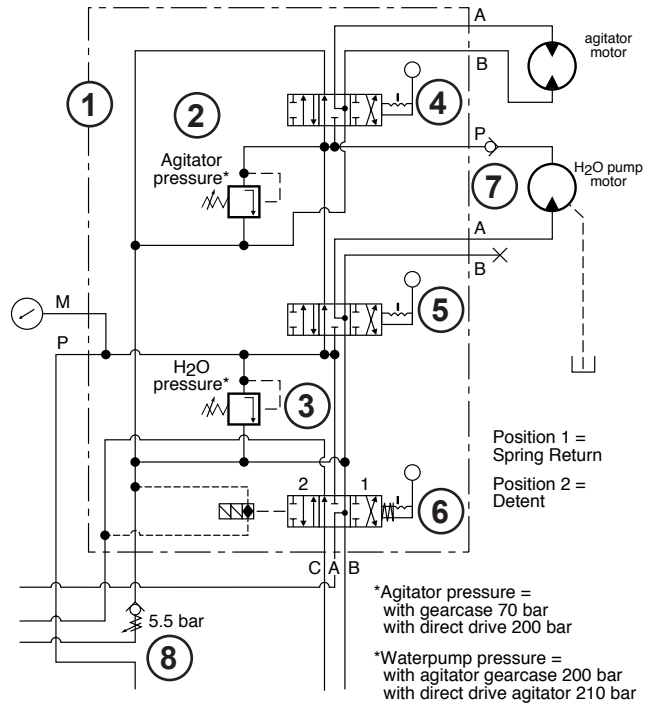

W1 The water pump does not work, although the tank is filled and the input is unobstructed.

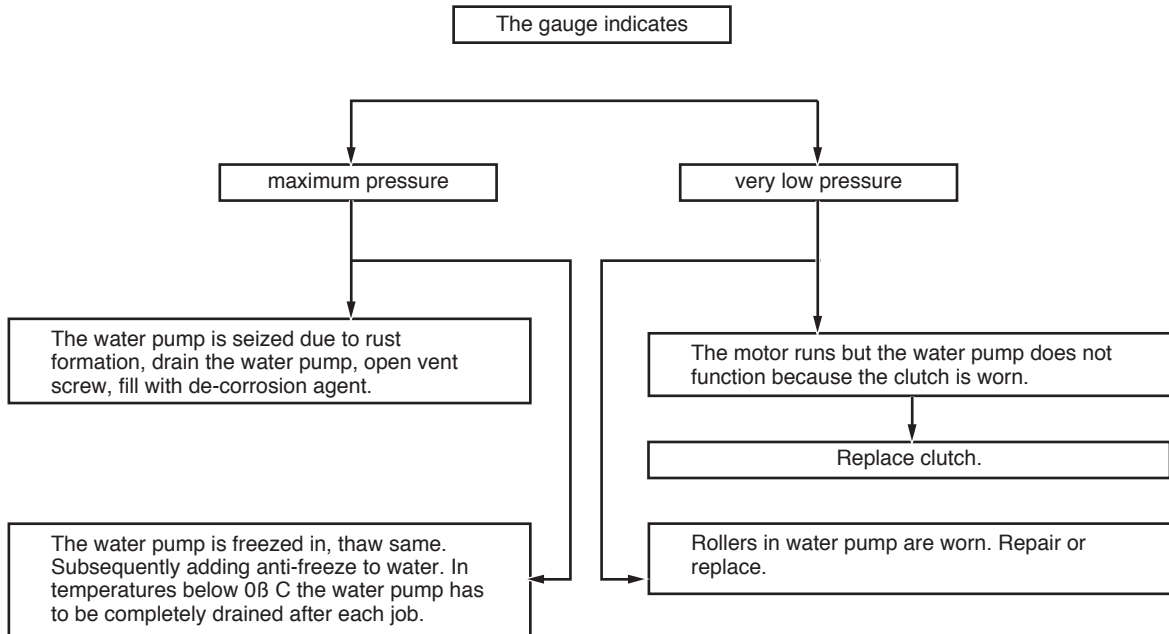

W2 Insufficient water is pumped by the pump and the pressure is low.

